

# PRO-FORM<sup>®</sup>

## 505 CST

[www.proform.com](http://www.proform.com)

Model No. PFTL60910.1

Serial No. \_\_\_\_\_

Write the serial number in the space above for reference.

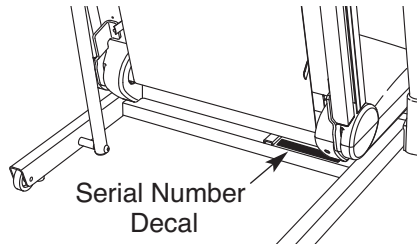

## USER'S MANUAL

### QUESTIONS?

If you have questions, or if parts are damaged or missing, **DO NOT CONTACT THE STORE**; please contact Customer Care.

**IMPORTANT:** Please register this product (see the limited warranty on the back cover of this manual) before contacting Customer Care.

CALL TOLL-FREE:

**1-888-533-1333**

Mon.–Fri. 6 a.m.–6 p.m. MT

Sat. 8 a.m.–4 p.m. MT

ON THE WEB:

[www.proformservice.com](http://www.proformservice.com)

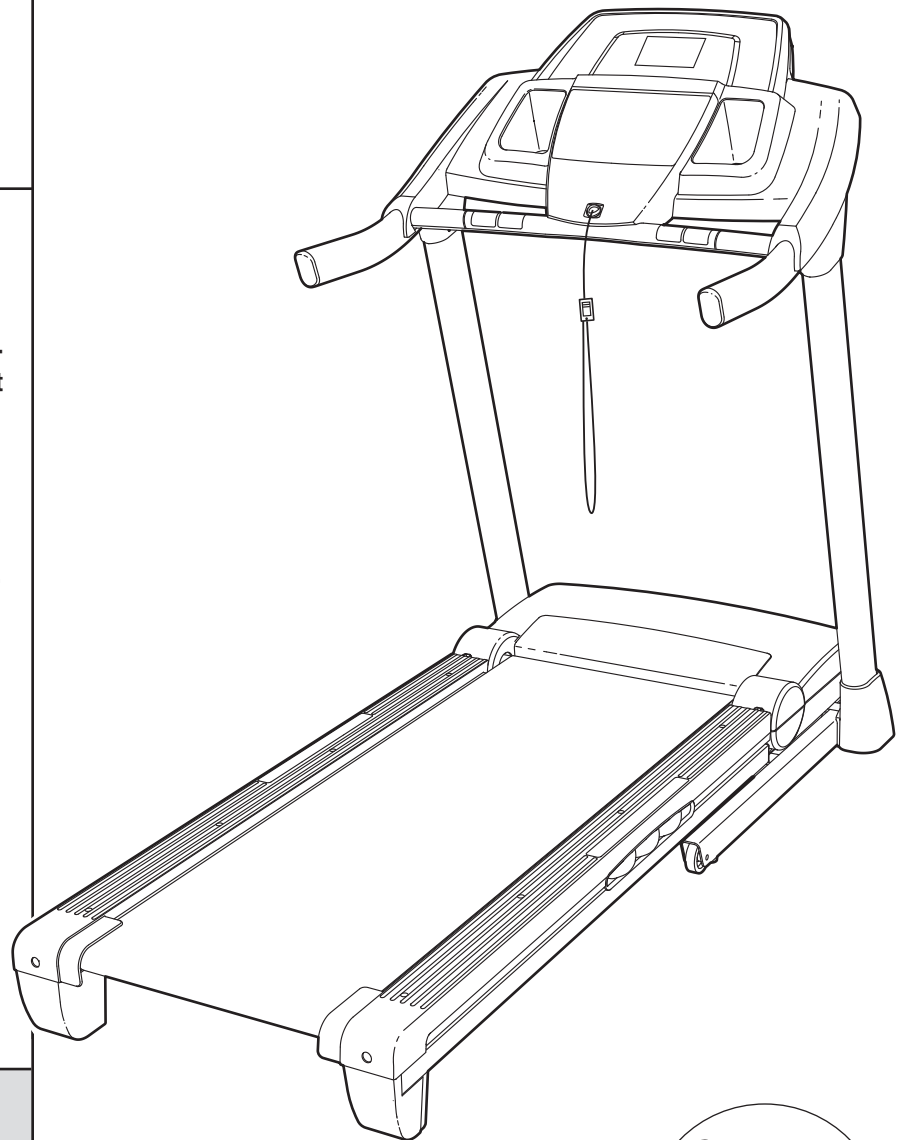

### **⚠ CAUTION**

Read all precautions and instructions in this manual before using this equipment. Save this manual for future reference.



# TABLE OF CONTENTS

WARNING DECAL PLACEMENT .....2

IMPORTANT PRECAUTIONS .....3

BEFORE YOU BEGIN .....5

ASSEMBLY .....6

OPERATION AND ADJUSTMENT .....13

HOW TO FOLD AND MOVE THE TREADMILL .....21

TROUBLESHOOTING .....22

EXERCISE GUIDELINES .....25

PART LIST .....26

EXPLODED DRAWING .....28

ORDERING REPLACEMENT PARTS .....Back Cover

LIMITED WARRANTY .....Back Cover



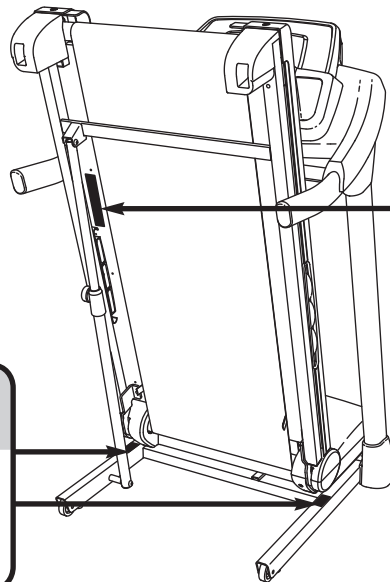

## WARNING DECAL PLACEMENT

This drawing shows the locations of the warning decals. **If a decal is missing or illegible, call the telephone number on the front cover of this manual and request a free replacement decal. Apply the decal in the location shown.** Note: The decals may not be shown at actual size.



**▲WARNING:**

Protect yourself and others from risk of serious injury. Read the user's manual and :

-  •Stand only on the side rails when starting or stopping treadmill.
- Change speed in small increments.
- Hold handrails to prevent falling, and always wear the safety clip while operating treadmill.
- Stop if you feel faint, dizzy, or short of breath.
- Fully engage storage latch before treadmill is moved or stored.
- Reduce incline to its lowest level before folding treadmill into storage position.
-  •Never allow children on or around treadmill.
- Remove key when not in use.
-  •Keep clothing, fingers, and hair away from moving belt.
- Never try to adjust or fix the belt while it is moving.
-  •Always wear athletic shoes while operating treadmill.

# IMPORTANT PRECAUTIONS

**⚠️ WARNING:** To reduce the risk of serious injury, read all important precautions and instructions in this manual and all warnings on your treadmill before using your treadmill. ICON assumes no responsibility for personal injury or property damage sustained by or through the use of this product.

1. Before beginning any exercise program, consult your physician. This is especially important for persons over age 35 or persons with pre-existing health problems.
2. It is the responsibility of the owner to ensure that all users of this treadmill are adequately informed of all warnings and precautions.
3. Use the treadmill only as described.
4. Keep the treadmill indoors, away from moisture and dust. Do not put the treadmill in a garage or covered patio, or near water.
5. Place the treadmill on a level surface, with at least 8 ft. (2.4 m) of clearance behind it and 2 ft. (0.6 m) on each side. Do not place the treadmill on any surface that blocks air openings. To protect the floor or carpet from damage, place a mat under the treadmill.
6. Do not operate the treadmill where aerosol products are used or where oxygen is being administered.
7. Keep children under age 12 and pets away from the treadmill at all times.
8. The treadmill should be used only by persons weighing 300 lbs. (136 kg) or less.
9. Never allow more than one person on the treadmill at a time.
10. Wear appropriate exercise clothes when using the treadmill. Do not wear loose clothes that could become caught in the treadmill. Athletic support clothes are recommended for both men and women. *Always wear athletic shoes. Never use the treadmill with bare feet, wearing only stockings, or in sandals.*
11. When connecting the power cord (see page 13), plug the power cord into a surge suppressor (not included) and plug the surge suppressor into a grounded circuit capable of carrying 15 or more amps. No other appliance should be on the same circuit. Do not use an extension cord.
12. Use only a single-outlet surge suppressor that meets all of the specifications described on page 13. To purchase a surge suppressor, see your local PROFORM dealer or call the telephone number on the front cover of this manual and order part number 146148, or see your local electronics store.
13. Failure to use a properly functioning surge suppressor could result in damage to the control system of the treadmill. If the control system is damaged, the walking belt may slow, accelerate, or stop unexpectedly, which may result in a fall and serious injury.
14. Keep the power cord and the surge suppressor away from heated surfaces.
15. Never move the walking belt while the power is turned off. Do not operate the treadmill if the power cord or plug is damaged, or if the treadmill is not working properly. (See TROUBLESHOOTING on page 22 if the treadmill is not working properly.)
16. Read, understand, and test the emergency stop procedure before using the treadmill (see HOW TO TURN ON THE POWER on page 15).
17. Never start the treadmill while you are standing on the walking belt. Always hold the handrails while using the treadmill.
18. The treadmill is capable of high speeds. Adjust the speed in small increments to avoid sudden jumps in speed.
19. The pulse sensor is not a medical device. Various factors, including the user's movement, may affect the accuracy of heart rate readings. The pulse sensor is intended only as an exercise aid in determining heart rate trends in general.

20. Never leave the treadmill unattended while it is running. Always remove the key, unplug the power cord, and press the power switch into the off position when the treadmill is not in use. (See the drawing on page 5 for the location of the power switch.)
21. Do not attempt to raise, lower, or move the treadmill until it is properly assembled. (See ASSEMBLY on page 6, and HOW TO FOLD AND MOVE THE TREADMILL on page 21.) You must be able to safely lift 45 lbs. (20 kg) to raise, lower, or move the treadmill.
22. When folding or moving the treadmill, make sure that the storage latch is holding the frame securely in the storage position.
23. Never insert any object into any opening on the treadmill.
24. Inspect and properly tighten all parts of the treadmill regularly.
25. **DANGER:** Always unplug the power cord immediately after use, before cleaning the treadmill, and before performing the maintenance and adjustment procedures described in this manual. Never remove the motor hood unless instructed to do so by an authorized service representative. Servicing other than the procedures in this manual should be performed by an authorized service representative only.
26. This treadmill is intended for in-home use only. Do not use this treadmill in a commercial, rental, or institutional setting.
27. Over exercising may result in serious injury or death. If you feel faint or if you experience pain while exercising, stop immediately and cool down.

**SAVE THESE INSTRUCTIONS**

# BEFORE YOU BEGIN

Thank you for selecting the revolutionary PROFORM® 505 CST treadmill. The 505 CST treadmill offers an impressive selection of features designed to make your workouts at home more enjoyable and effective. And when you're not exercising, the unique treadmill can be folded up, requiring less than half the floor space of other treadmills.

**For your benefit, read this manual carefully before using the treadmill.** If you have questions after read-

ing this manual, please see the front cover of this manual. To help us assist you, please note the product model number and serial number before contacting us. The model number and the location of the serial number decal are shown on the front cover of this manual.

Before reading further, please review the drawing below and familiarize yourself with the labeled parts.

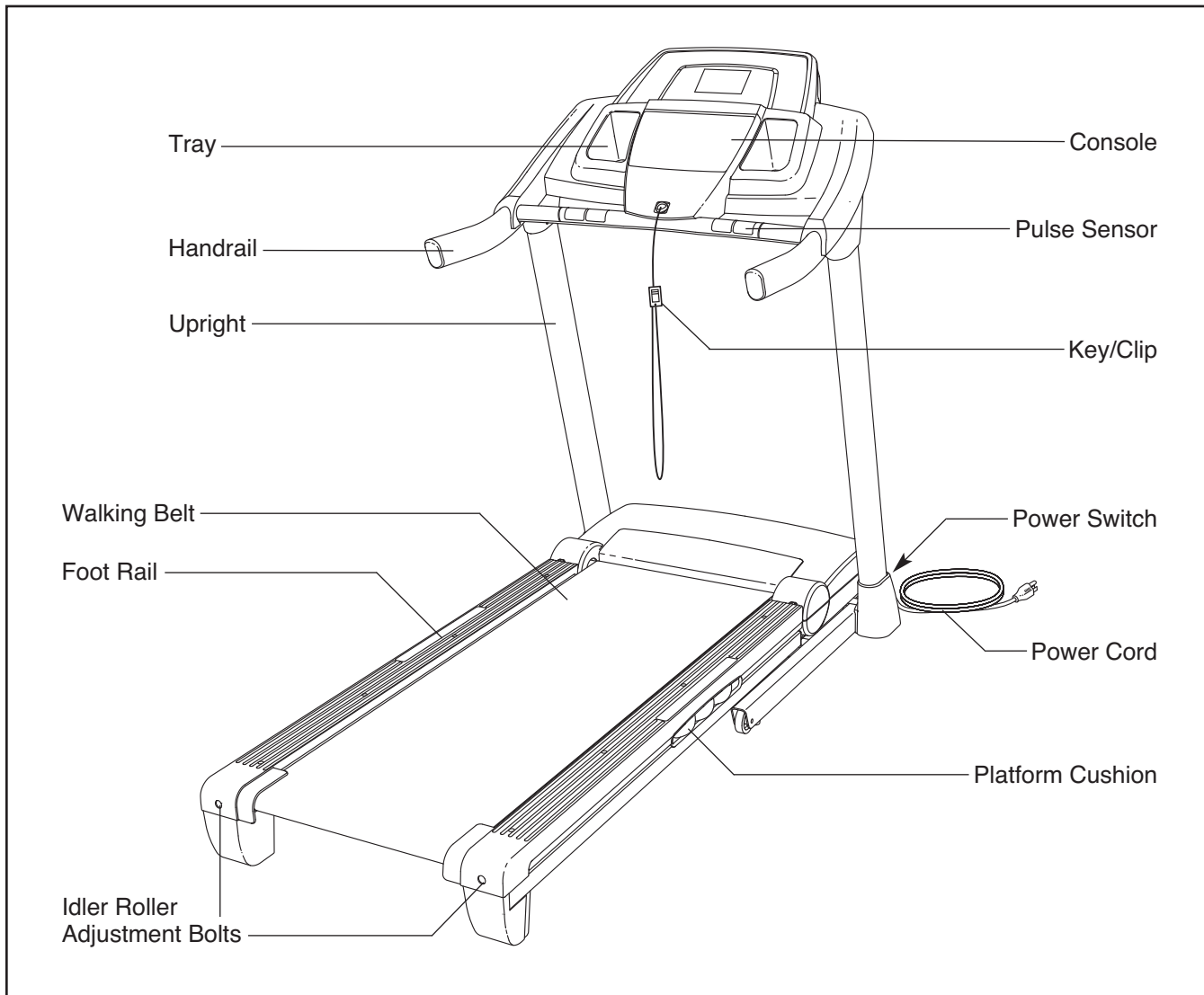

# ASSEMBLY

To hire an authorized service technician to assemble the treadmill, call 1-800-445-2480.

**Assembly requires two persons.** Set the treadmill in a cleared area and remove all packing materials. **Do not dispose of the packing materials until assembly is completed.** Note: The underside of the treadmill walking belt is coated with high-performance lubricant. During shipping, some lubricant may be transferred to the top of the walking belt or the shipping carton. This is normal and does not affect treadmill performance. If there is lubricant on top of the walking belt, simply wipe off the lubricant with a soft cloth and a mild, non-abrasive cleaner.

**Assembly requires the included hex keys**  **and your own Phillips screwdriver**  **, adjustable wrench**  **, needlenose pliers**  **, and scissors** .

Use the drawings below to identify the assembly hardware. The number in parentheses below each drawing is the key number of the part, from the PART LIST near the end of this manual. The number after the parentheses is the quantity needed for assembly. **Note: Some small parts may have been preassembled. To avoid damaging parts, do not use power tools for assembly. Extra hardware may be included.**

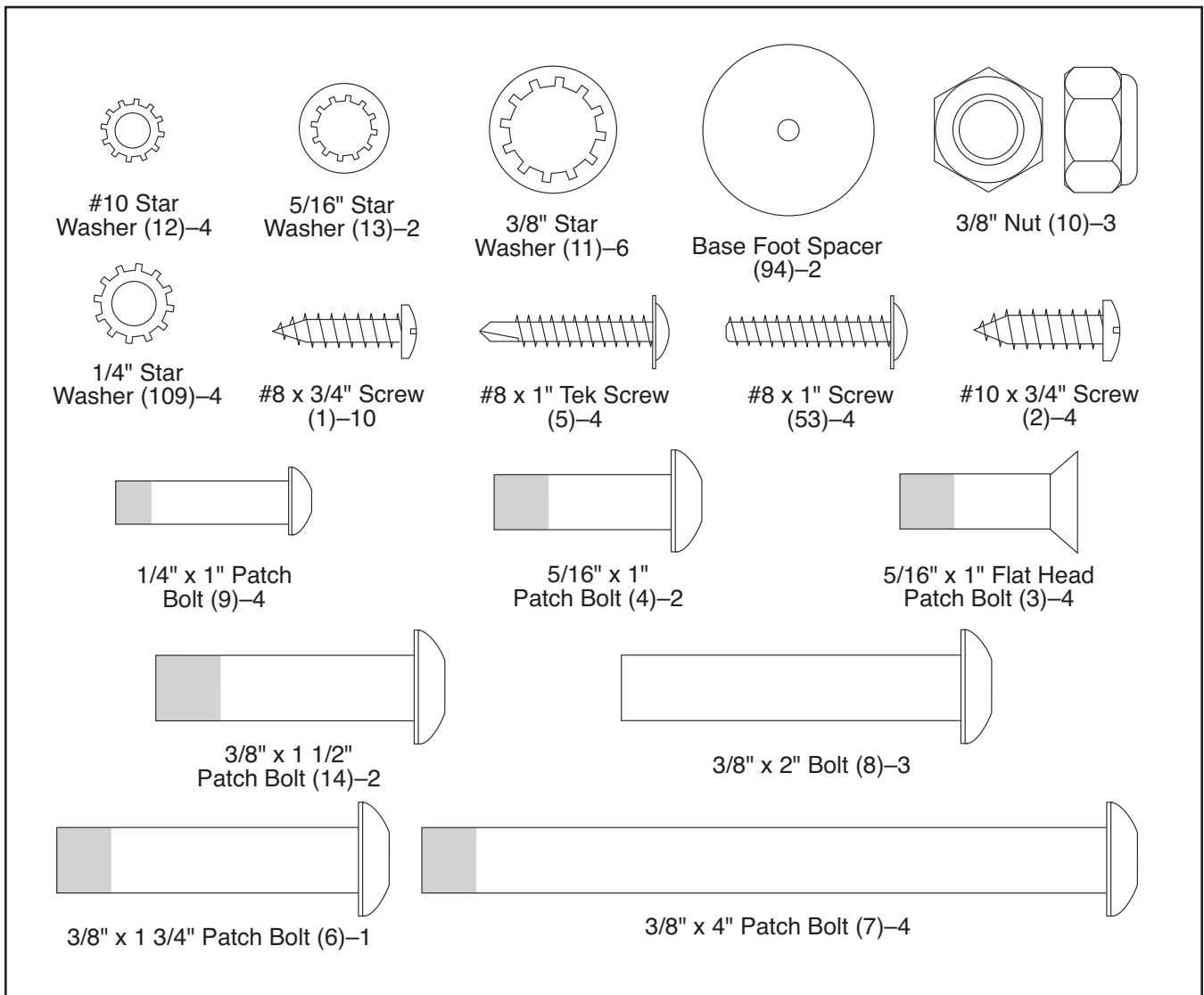

1. **Make sure that the power cord is unplugged.**

With the help of a second person, carefully tip the treadmill onto its left side. Partially fold the Frame (55) so that the treadmill is more stable; **do not fully fold the Frame yet.**

Cut the shipping tie securing the Upright Wire (87) to the Base (95). Locate a plastic tie in the indicated hole in the Base, and use the tie to pull the Upright Wire out of the hole.

Attach two Base Feet (90) to the Base (95) in the locations shown with two #8 x 1" Tek Screws (5) and two Base Foot Spacers (94).

Then, attach the other two Base Feet (90) with two #8 x 1" Tek Screws (5).

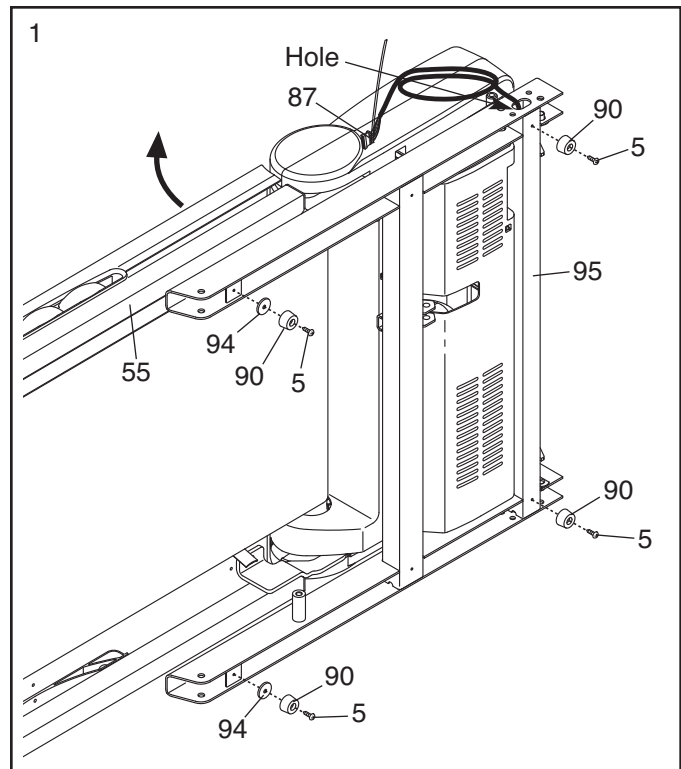

2. Attach a Wheel (96) to the Base (95) with a 3/8" x 2" Bolt (8) and a 3/8" Nut (10). **Do not over-tighten the Nut; the Wheel must turn freely.**

Press a Base Cap (89) into the Base (95).

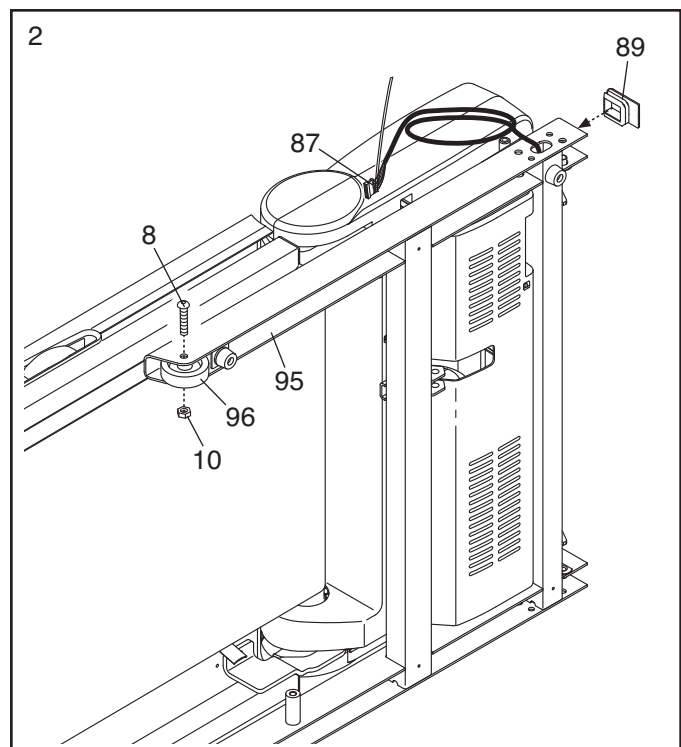

- Identify the Right Upright (85), which is marked with a "Right" sticker. Hold the Right Upright near the Base (95) as shown.

**See the inset drawing.** Tie the wire tie in the Right Upright (85) securely around the end of the Upright Wire (87). Then, pull the other end of the wire tie until the Upright Wire is routed completely through the Right Upright.

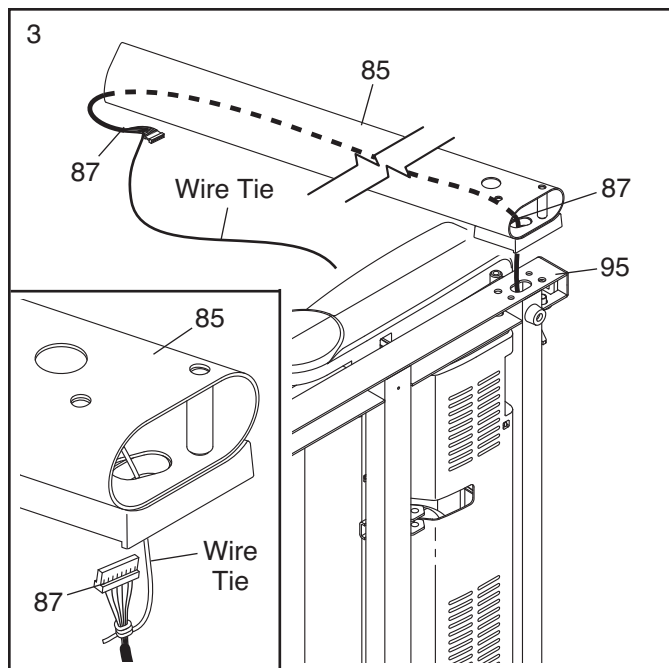

- Hold the Right Upright (85) against the Base (95). **Be careful not to pinch the Upright Wire (87).** Insert two 3/8" x 4" Bolts (7) with two 3/8" Star Washers (11) and a 3/8" x 1 1/2" Bolt (14) with a 3/8" Star Washer (11) into the Right Upright.

Partially tighten the 3/8" x 4" Bolts (7) until the heads of the Bolts touch the Right Upright (85); **do not fully tighten the Bolts yet.** Partially tighten the 3/8" x 1 1/2" Bolt (14).

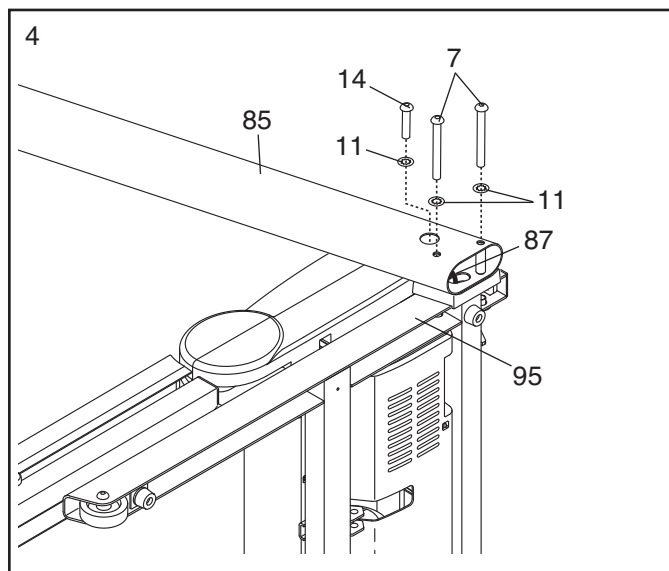

- With the help of a second person, carefully tip the treadmill onto its right side. Partially fold the Frame (55) so that the treadmill is more stable; **do not fully fold the Frame yet.**

Attach a Wheel (96) to the Base (95) with a 3/8" x 2" Bolt (8) and a 3/8" Nut (10). **Do not over-tighten the Nut; the Wheel must turn freely.**

Press a Base Cap (89) into the Base (95).

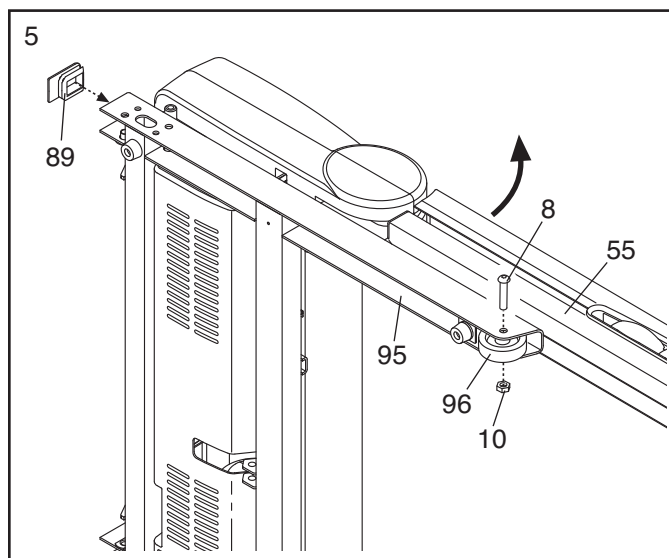

6. Hold the Left Upright (84) against the Base (95). Insert two 3/8" x 4" Bolts (7) with two 3/8" Star Washers (11) and a 3/8" x 1 1/2" Bolt (14) with a 3/8" Star Washer (11) into the Left Upright.

Partially tighten the 3/8" x 4" Bolts (7) until the heads of the Bolts touch the Left Upright (84); **do not fully tighten the Bolts yet.** Partially tighten the 3/8" x 1 1/2" Bolt (14).

With the help of a second person, tip the treadmill so that the Base (95) is flat on the floor.

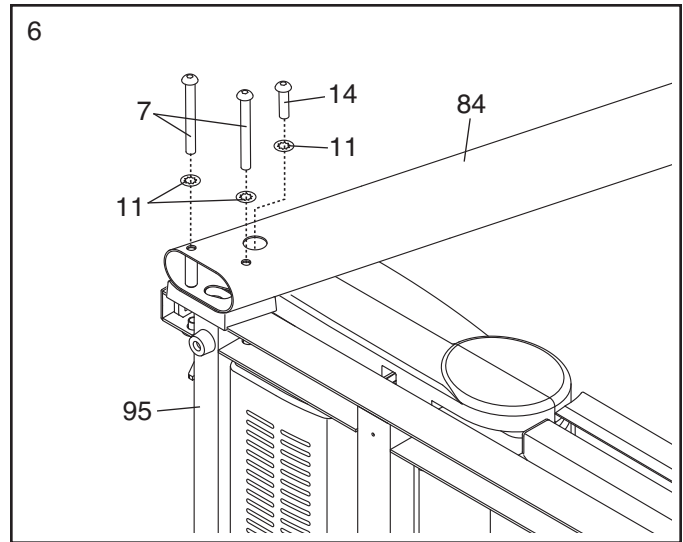

7. Identify the Left Base Cover (88) and the Right Base Cover (91). Slide the Left Base Cover onto the Left Upright (84). Slide the Right Base Cover onto the Right Upright (85).

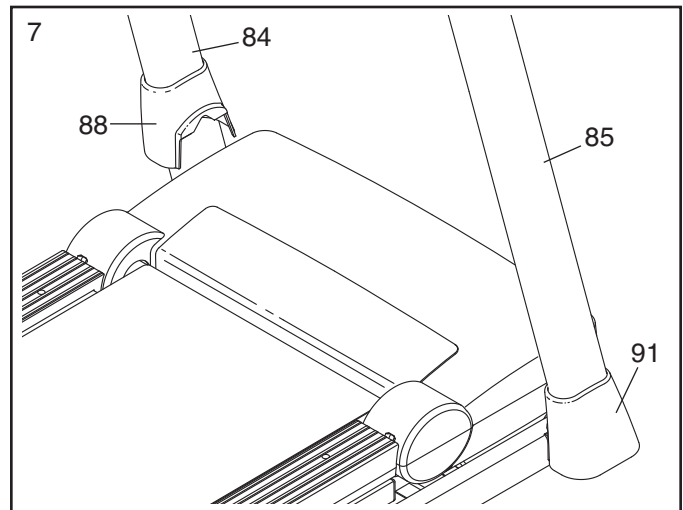

8. Slide the Right Upright Cover (86) onto the Right Upright (85). Remove the tie from the bracket on the Right Handrail (83). If necessary, press the 5/16" Cage Nuts (38) back into place.

Hold the Right Handrail (83) near the Right Upright (85). Insert the Upright Wire (87) through the bracket on the bottom of the Right Handrail. Pull the Upright Wire out of the end of the Right Handrail.

Attach the Right Handrail (83) to the Right Upright (85) with two 5/16" x 1" Flat Head Patch Bolts (3) and a 5/16" x 1" Patch Bolt (4) with a 5/16" Star Washer (13); **do not tighten the Patch Bolts yet.**

**Attach the Left Upright Cover (80) and the Left Handrail (82) in the same way.** Note: There is no wire on the left side.

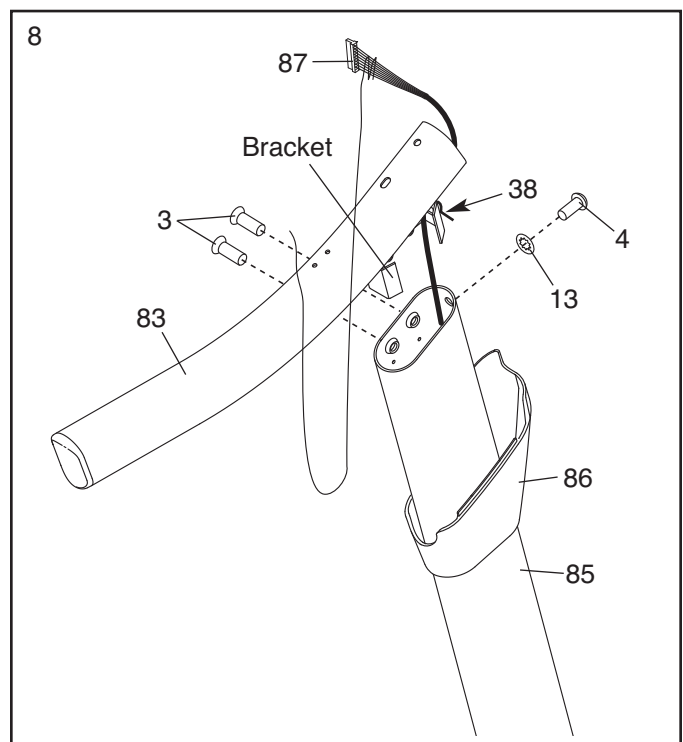

9. Set the console assembly face down on a soft surface to avoid scratching the console assembly. Remove the two #8 x 3/4" Screws (1). Next, lift off the Crossbar (107).

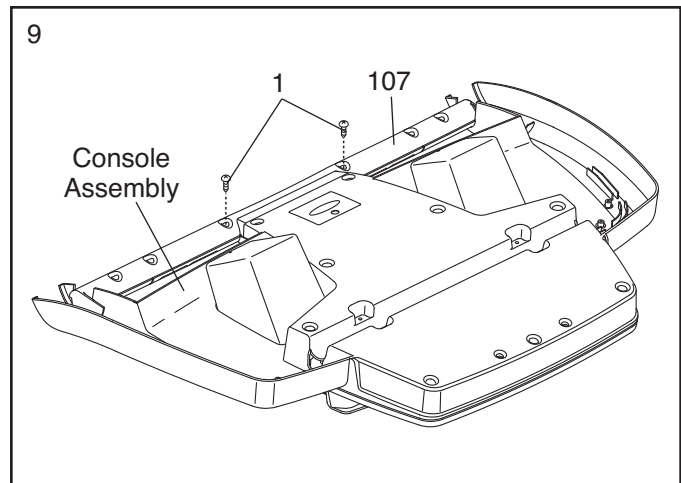

10. **IMPORTANT: To avoid damaging the Crossbar (107), do not use power tools and do not overtighten the #10 x 3/4" Screws (2).**

Orient the Crossbar (107) as shown. Attach the Crossbar to the Handrails (82, 83) with four #10 x 3/4" Screws (2) and four #10 Star Washers (12); **do not fully tighten the Screws yet.** **Note: The #10 Star Washers are slightly smaller than the 1/4" Star Washers (109).**

Insert the Console Frame (102) into the Handrails (82, 83). Attach the Console Frame with four 1/4" x 1" Patch Bolts (9) and four 1/4" Star Washers (109); **do not tighten the Patch Bolts yet. Be careful not to pinch the Upright Wire (87).**

**Tighten one #10 x 3/4" Screw (2) in each end of the Crossbar (107); do not overtighten the Screws.** Then, tighten the other #10 x 3/4" Screw (2) in each end of the Crossbar.

**Tighten the four 1/4" x 1" Patch Bolts (9).**

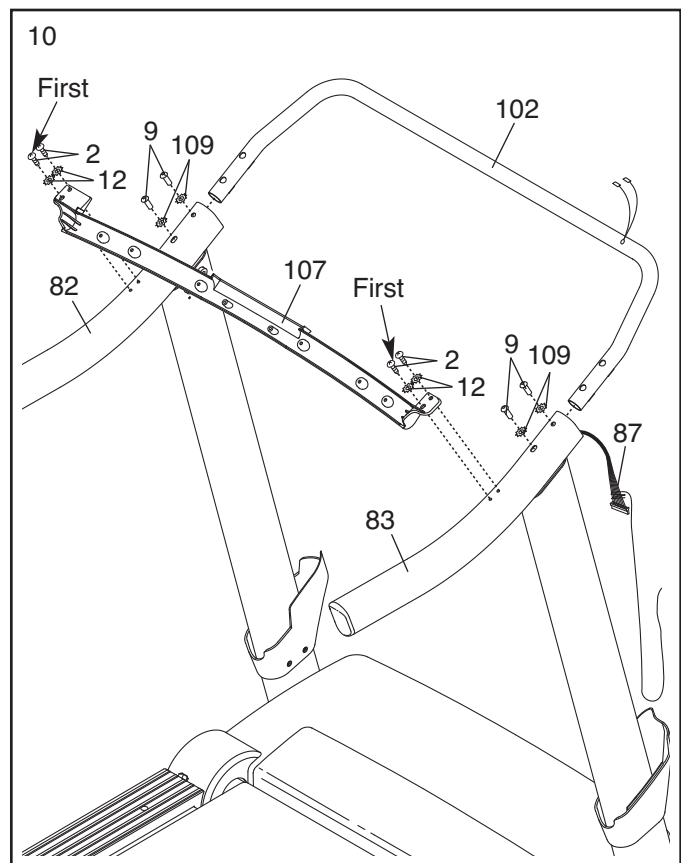

11. Firmly tighten the four 5/16" x 1" Flat Head Patch Bolts (3) and the two 5/16" x 1" Patch Bolts (4) (only one side is shown).

With the help of a second person, hold the console assembly near the Right Handrail (83) and the Left Handrail (not shown).

Connect the Upright Wire (87) to the console wire. **See the inset drawing. The connectors should slide together easily and snap into place.** If they do not, turn one connector and try again. **IF YOU DO NOT CONNECT THE CONNECTORS PROPERLY, THE CONSOLE MAY BECOME DAMAGED WHEN YOU TURN ON THE POWER.** Remove the wire tie from the Upright Wire.

Connect the ground wires from the console assembly to the Console Ground Wires (52).

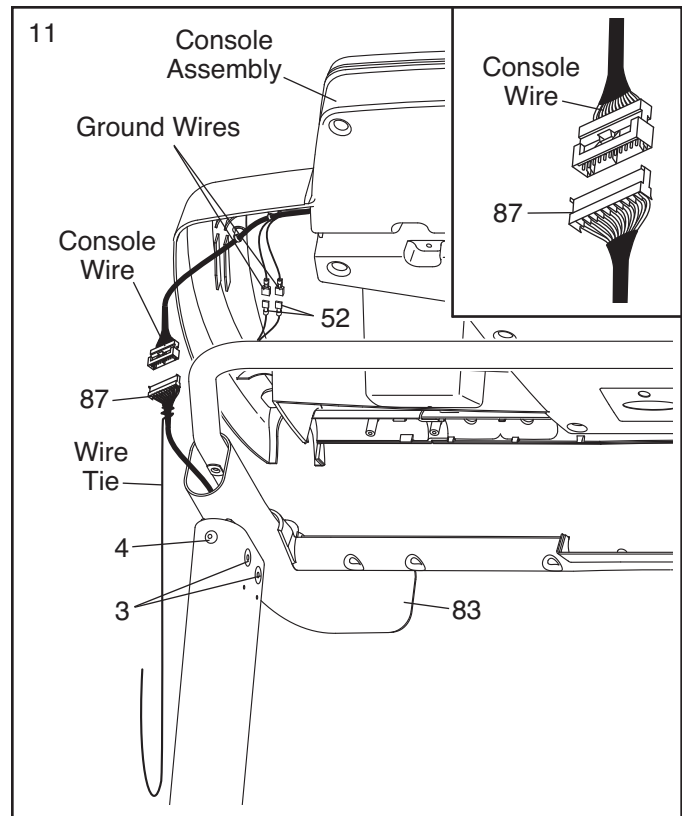

12. Set the console assembly on the Left and Right Handrails (82, 83). **Be careful not to pinch any wires.** Insert the excess Upright Wire (87) into the Right Handrail.

Attach the console assembly to the Crossbar (107) with six #8 x 3/4" Screws (1). **Start all six Screws, and then tighten each of them.**

Attach the two Console Clamps (105) to the console assembly with four #8 x 1" Screws (53).

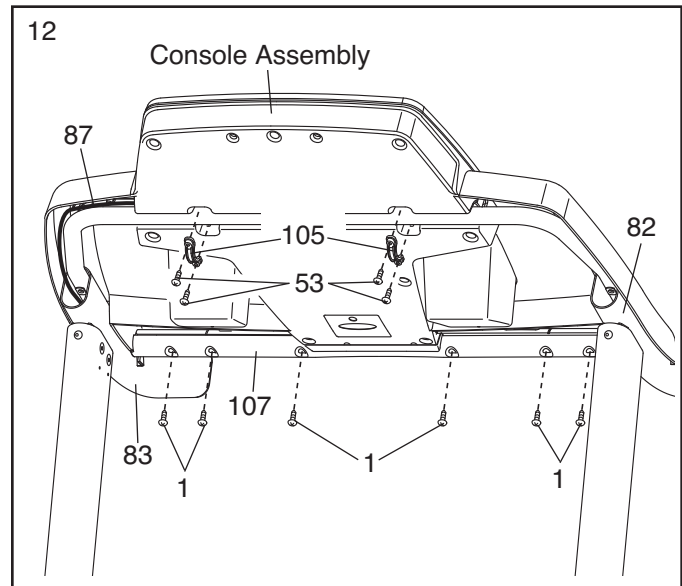

13. Hold the Right Upright Cover (86) against the console assembly. Align the holes in the Right Upright Cover with the holes in the Right Upright (85). Attach the Right Upright Cover with two #8 x 3/4" Screws (1).

Attach the Left Upright Cover (80) to the Left Upright (84) in the same way.

**See steps 4 and 6.** Tighten the four 3/8" x 4" Patch Bolts (7) and the two 3/8" x 1 1/2" Patch Bolts (14).

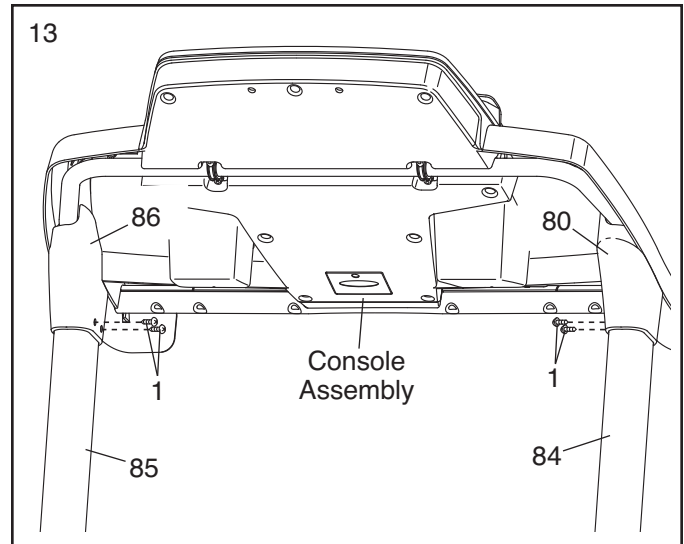

14. Raise the Frame (55) to the position shown. **Have a second person hold the Frame until this step is completed.**

Orient the Storage Latch (51) so that the large barrel and the latch knob are oriented as shown.

Attach the upper end of the Storage Latch (51) to the bracket on the Frame (55) with a 3/8" x 2" Bolt (8) and a 3/8" Nut (10).

Attach the lower end of the Storage Latch (51) to the Base (95) with a 3/8" x 1 3/4" Patch Bolt (6). Note: It may be necessary to move the Frame (55) back and forth to align the Storage Latch with the Base.

Lower the Frame (55) (see HOW TO LOWER THE TREADMILL FOR USE on page 21).

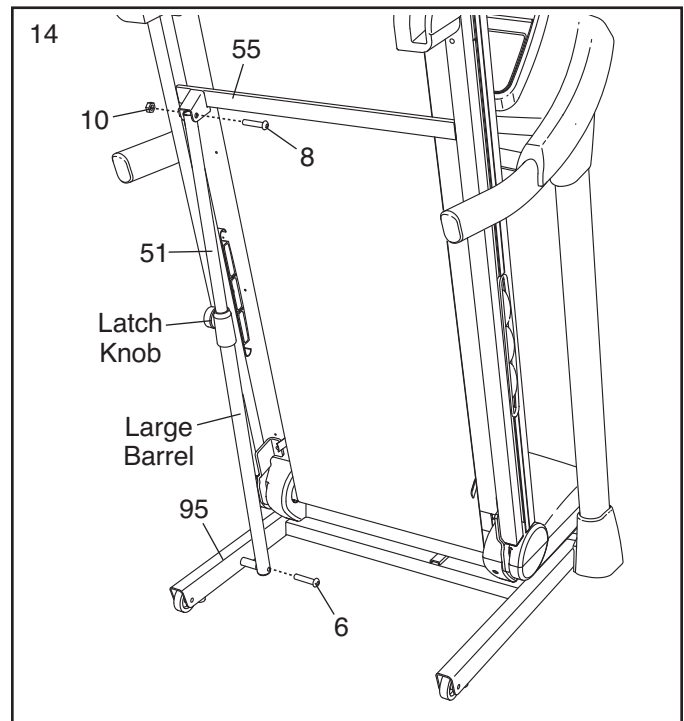

15. **Make sure that all parts are properly tightened before you use the treadmill.** If there are sheets of plastic on the treadmill decals, remove the plastic. To protect the floor or carpet, place a mat under the treadmill. Note: Extra hardware may be included. Keep the included hex keys in a secure place; one of the hex keys is used to adjust the walking belt (see pages 23 and 24).

# OPERATION AND ADJUSTMENT

## THE PRE-LUBRICATED WALKING BELT

Your treadmill features a walking belt coated with high-performance lubricant. **IMPORTANT: Never apply silicone spray or other substances to the walking belt or the walking platform. Such substances will cause excessive wear.**

## HOW TO PLUG IN THE POWER CORD

**⚠ DANGER:** Improper connection of the equipment-grounding conductor increases the risk of electric shock. Check with a qualified electrician or serviceman if you are unsure whether the product is properly grounded. Do not modify the plug—if it will not fit the outlet, have a proper outlet installed by a qualified electrician.

Your treadmill, like other electronic equipment, can be damaged by sudden voltage changes in your home's power. **To decrease the risk of damaging your treadmill, always use a surge suppressor with your treadmill (see drawing 1 at the right). To purchase a surge suppressor, see precaution 12 on page 3.**

**Use only a single-outlet surge suppressor that is UL 1449 listed as a transient voltage surge suppressor (TVSS). The surge suppressor must have a UL suppressed voltage rating of 400 volts or less and a minimum surge dissipation of 450 joules. The surge suppressor must be electrically rated for 120 volts AC and 15 amps. There must be a monitoring light on the surge suppressor to indicate whether it is functioning properly. Failure to use a properly functioning surge suppressor could damage the control system of the treadmill (see precaution 13 on page 3).**

**This product must be grounded.** If it should malfunction or break down, grounding provides a path of least resistance for electric current to reduce the risk of electric shock. This product's power cord has an equipment-grounding conductor and a grounding plug. **Plug the power cord into a surge suppressor, and plug the surge suppressor into an appropriate outlet**

that is properly installed and grounded in accordance with all local codes and ordinances. **IMPORTANT: The treadmill is not compatible with GFCI-equipped outlets.**

This product is for use on a nominal 120-volt circuit (see drawing 1). A temporary adapter may be used to connect the surge suppressor to a 2-pole receptacle if a properly grounded outlet is not available (see drawing 2).

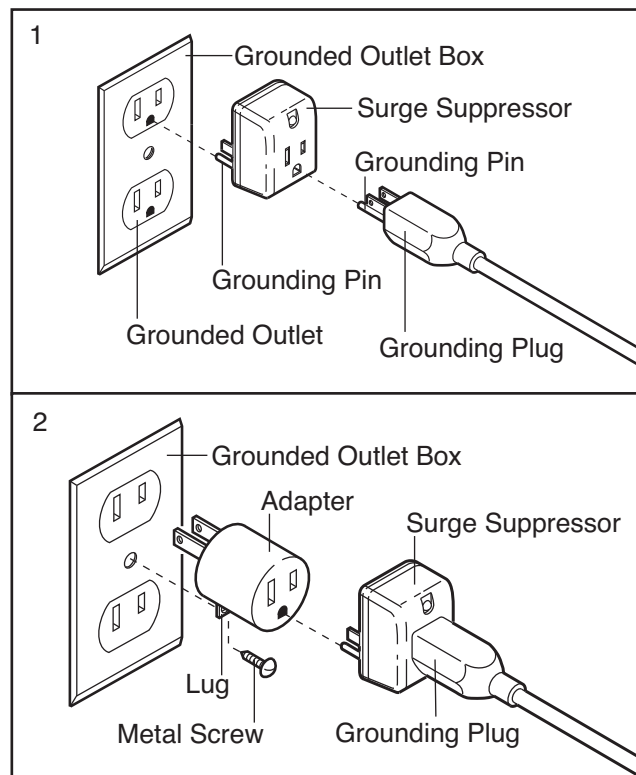

The temporary adapter should be used only until a properly grounded outlet (see drawing 1) can be installed by a qualified electrician.

The green-colored rigid ear, lug, or the like extending from the adapter must be connected to a permanent ground such as a properly grounded outlet box cover. The adapter must be held in place by a metal screw. **Some 2-pole receptacle outlet box covers are not grounded. Contact a qualified electrician to determine if the outlet box cover is grounded before using an adapter.**

## CONSOLE DIAGRAM

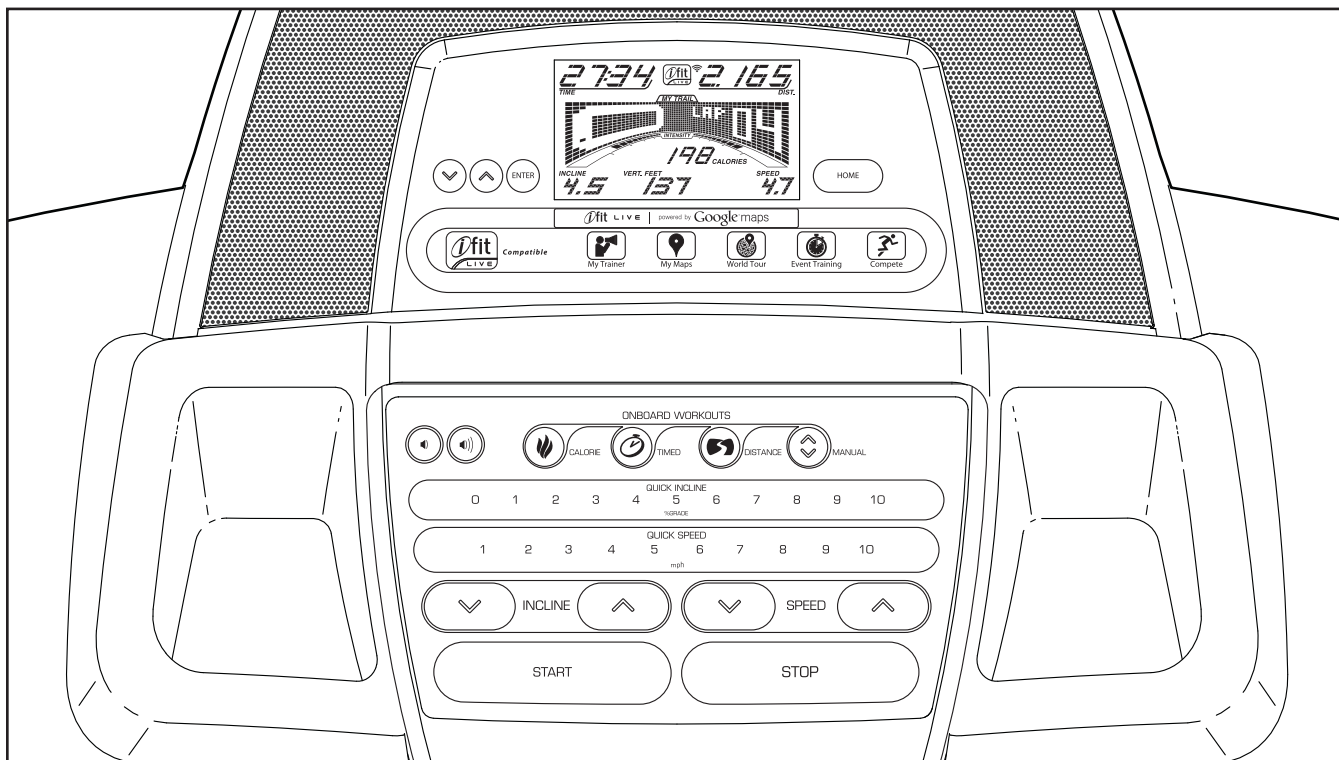

### FEATURES OF THE CONSOLE

The treadmill console offers an impressive array of features designed to make your workouts more effective and enjoyable. When you use the manual mode, you can change the speed and incline of the treadmill with the touch of a button. As you exercise, the console will display instant exercise feedback. You can even measure your heart rate using the handgrip pulse sensor.

In addition, the console features fifteen onboard workouts—five calorie workouts, five timed workouts, and five distance workouts. Each workout automatically controls the speed and incline of the treadmill as it guides you through an effective exercise session.

The console also features an iFit Live mode that enables the treadmill to communicate with your wireless network through an optional iFit Live module. With the iFit Live mode, you can download personalized workouts, create your own workouts, track your workout results, race against other runners, and access many other features. **To purchase an iFit Live module at any time, go to [www.iFit.com](http://www.iFit.com) or call the telephone number on the front cover of this manual.**

You can even listen to your favorite workout music or audio books with the console's stereo sound system while you exercise.

**To turn on the power**, see page 15. **To use the manual mode**, see page 15. **To use an onboard workout**, see page 17. **To use an iFit Live workout**, see page 18. **To use the stereo sound system**, see page 19. **To use the information mode**, see page 20.

Note: The console can display speed and distance in either miles or kilometers. To find which unit of measurement is selected, see THE INFORMATION MODE on page 20. For simplicity, all instructions in this manual refer to miles.

**IMPORTANT: If there are sheets of plastic on the console, remove the plastic. To prevent damage to the walking platform, wear clean athletic shoes while using the treadmill. The first time you use the treadmill, observe the alignment of the walking belt, and center the walking belt if necessary (see page 24).**

## HOW TO TURN ON THE POWER

**IMPORTANT:** If the treadmill has been exposed to cold temperatures, allow it to warm to room temperature before turning on the power. If you do not do this, you may damage the console displays or other electrical components.

Plug in the power cord (see page 13). Next, locate the power switch on the treadmill frame near the power cord. Press the power switch into the reset position.

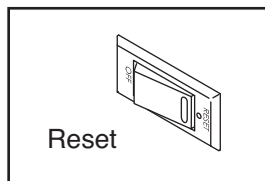

**IMPORTANT:** The console features a display demo mode, designed to be used if the treadmill is displayed in a store. If the displays light as soon as you plug in the power cord and press the power switch into the reset position, the demo mode is turned on. To turn off the demo mode, hold down the Stop button for a few seconds. If the displays remain lit, see THE INFORMATION MODE on page 20 to turn off the demo mode.

Next, stand on the foot rails of the treadmill. Find the clip attached to the key and slide the clip onto the waistband of your clothes. Then, insert the key into the console. After a moment, the displays will light. **IMPORTANT:** In an emergency, the key can be pulled from the console, causing the walking belt to slow to a stop. Test the clip by carefully taking a few steps backward; if the key is not pulled from the console, adjust the position of the clip.

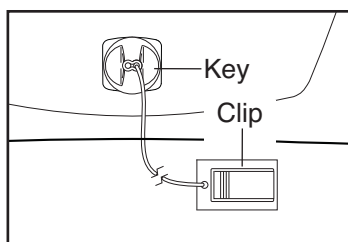

## HOW TO USE THE MANUAL MODE

### 1. Insert the key into the console.

See HOW TO TURN ON THE POWER above.

### 2. Select the manual mode.

Press the Manual button on the console. If you are not connected to iFit Live, the manual mode will be selected automatically.

### 3. Start the walking belt.

To start the walking belt, press the Start button, the Speed increase button, or one of the Quick Speed buttons numbered 1 through 10.

If you press the Start button or the Speed increase button, the walking belt will begin to move at 1 mph. As you exercise, change the speed of the walking belt as desired by pressing the Speed increase and decrease buttons. Each time you press one of the buttons, the speed setting will change by 0.1 mph; if you hold down the button, the speed setting will change in increments of 0.5 mph. Note: After you press the button, it may take a moment for the walking belt to reach the selected speed setting.

If you press one of the numbered Quick Speed buttons, the walking belt will gradually change speed until it reaches the selected speed setting.

To stop the walking belt, press the Stop button. The time will begin to flash in the display. To restart the walking belt, press the Start button or the Speed increase button.

### 4. Change the incline of the treadmill as desired.

To change the incline of the treadmill, press the Incline increase or decrease button or one of the numbered Quick Incline buttons. Each time you press one of the buttons, the treadmill will gradually adjust to the selected incline setting.

### 5. Follow your progress with the displays.

As you walk or run on the treadmill, the display can show the following workout information:

- The elapsed time
- The distance that you have walked or run
- The matrix
- The workout intensity bar
- The approximate number of calories you have burned

- The incline level of the treadmill
- The number of vertical feet you have climbed
- The speed of the walking belt
- Your heart rate (see step 6 on this page)

The matrix offers several display tabs. Press the increase and decrease button next to the Enter button until the desired tab is shown.

The Incline tab will show a profile of the incline settings of the workout. A new segment will appear at the end of each minute. The Speed tab will show a profile of the speed settings of the workout. The My Trail tab will show a track that represents 1/4 mile (400 meters). As you exercise, the white rectangle will show your progress. The My Trail tab will also show the number of laps you are completing.

The Calorie tab will show the approximate amount of calories you have burned. The height of each segment represents the amount of calories burned during that segment.

As you exercise, the workout intensity level bar will indicate the approximate intensity level of your exercise.

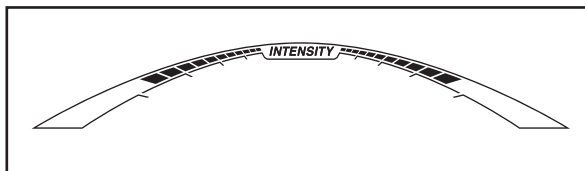

Press the Home button to return to the default menu (see THE INFORMATION MODE on page 20 to set the default menu). If necessary, press the Home button again.

When a wireless iFit Live module is connected, the wireless symbol at the top of the display will show the strength of your wireless signal. Four arcs indicate full signal strength.

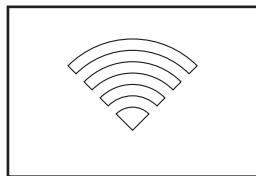

To reset the displays, press the Stop button, remove the key, and then reinsert the key.

## 6. Measure your heart rate if desired.

Before using the handgrip pulse sensor, remove the sheets of plastic from the metal contacts on the pulse bar. In addition, make sure that your hands are clean.

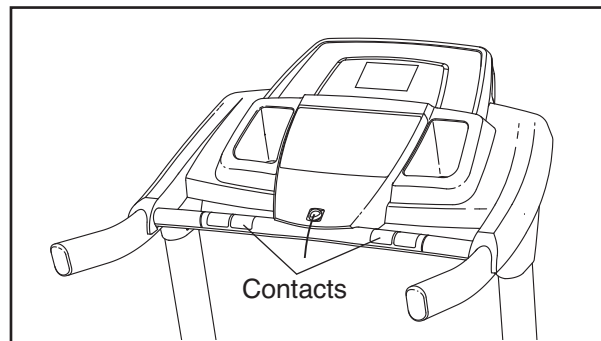

To measure your heart rate, **stand on the foot rails** and hold the pulse bar with your palms on the metal contacts for approximately ten seconds; **avoid moving your hands.** When your pulse is detected, a heart symbol in the calorie display will flash each time your heart beats, one or two dashes will appear, and then your heart rate will be shown. **For the most accurate heart rate reading, continue to hold the contacts for about 15 seconds.**

## 7. When you are finished exercising, remove the key from the console.

Step onto the foot rails, press the Stop button, and **adjust the incline of the treadmill to the lowest setting. The incline must be at the lowest setting or you may damage the treadmill when you fold it to the storage position.** Next, remove the key from the console and put it in a secure place.

When you are finished using the treadmill, press the power switch into the off position and unplug the power cord. **IMPORTANT: If you do not do this, the treadmill's electrical components may wear prematurely.**

## HOW TO USE AN ONBOARD WORKOUT

### 1. Insert the key into the console.

See HOW TO TURN ON THE POWER on page 15.

### 2. Select an onboard workout.

To select an onboard workout, press the Calorie button, the Timed button, or the Distance button repeatedly until the desired workout appears in the display.

When you select an onboard workout, the display will show the duration of the workout and the name of the workout. In addition, a profile of the speed settings of the workout will appear in the matrix. If you select a distance workout, the distance you will walk or run will appear in the display instead of the workout duration. If you select a calorie workout, the approximate number of calories you will burn will appear in the name of the workout.

### 3. Start the workout.

Press the Start button or the Speed increase button to start the workout. A moment after you press the button, the treadmill will automatically adjust to the first speed and incline settings of the workout. Hold the handrails and begin walking. Note: If you select a distance workout, the exercise session will begin with a three-minute warm-up segment before the distance workout begins.

Each workout is divided into segments. One speed setting and one incline setting are programmed for each segment. Note: The same speed setting and/or incline setting may be programmed for consecutive segments.

During the workout, the profiles on the speed and incline tabs will show your progress. The flashing segment of the profile represents the current segment of the workout. The height of the flashing segment indicates the speed or incline setting for the current segment. At the end of each segment, a series of tones will sound and the next segment of the profile will begin to flash. If a different speed and/or incline setting is programmed for the next segment, the treadmill will automatically adjust to the new speed and/or incline setting. Note: If you select a distance workout, the next segment of the profile will not flash in the display.

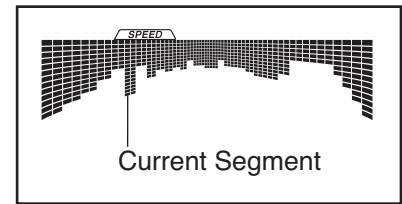

The workout will continue in this way until the last segment of the profile flashes in the display and the last segment ends. The walking belt will then slow to a stop. Note: If you select a distance workout, the workout will end with a three-minute cool-down segment.

**Note: The calorie goal is an estimate of the number of calories that you will burn during the workout. The actual number of calories that you burn will depend on your weight. In addition, if you manually change the speed or incline of the treadmill during the workout, the number of calories you burn will be affected.**

If the speed or incline setting is too high or too low at any time during the workout, you can manually override the setting by pressing the Speed or Incline buttons; **however, when the next segment of the workout begins, the treadmill will automatically adjust to the speed and incline settings for the next segment.**

To stop the workout at any time, press the Stop button. The time will begin to flash in the display. To resume the workout, press the Start button or the Speed increase button. The walking belt will begin to move at 1 mph. When the next segment of the workout begins, the treadmill will automatically adjust to the speed and incline settings for the next segment.

**4. Follow your progress with the displays.**

See step 5 on pages 15 and 16. If you select a calorie workout or a timed workout, the display will show the time remaining instead of the elapsed time.

**5. Measure your heart rate if desired.**

See step 6 on page 16.

**6. When you are finished exercising, remove the key from the console.**

See step 7 on page 16.

## HOW TO USE AN IFIT LIVE WORKOUT

**1. Insert the key into the console.**

See HOW TO TURN ON THE POWER on page 15.

**2. Insert the iFit Live module into the console.**

To use an iFit Live workout, insert the optional iFit Live module into the console. To purchase an iFit Live module at any time, go to [www.iFit.com](http://www.iFit.com) or call the telephone number on the front cover of this manual. You must have an iFit Live module to use an iFit Live workout.

Note: To use an iFit Live module, you must have access to a computer with an internet connection and a USB port. You will also need an iFit.com membership. To use a wireless iFit Live module, you must also have your own wireless network including an 802.11b router with SSID broadcast enabled (hidden networks are not supported).

**3. Select a user.**

If more than one user is registered, you can switch users in the iFit Live main screen. Press the increase and decrease buttons next to the Enter button to select a user.

**4. Select an iFit Live workout.**

To select an iFit Live workout, press one of the iFit Live buttons. Before a workout will download, you must add the workout to your queue on [www.iFit.com](http://www.iFit.com).

Press the iFit Live button to download the next workout in your queue. Press the My Trainer button, the My Maps button, the World Tour button, or the Event Training button to download the next workout of that type in your queue. Press the Compete button to compete in a race that you have previously scheduled. For more information on the iFit Live workouts, please see [www.iFit.com](http://www.iFit.com).

When you select an iFit Live workout, the display will show the duration of the workout, the distance you will walk or run, and the approximate number of calories you will burn. The display may also show the name of the workout. If you select a competition workout, the display will count down to the beginning of the race.

#### 5. Start the workout.

See step 3 on pages 17 and 18.

During some workouts, the voice of a personal trainer will guide you through your workout. You can select an audio setting for your personal trainer (see THE INFORMATION MODE on page 20).

To stop the workout at any time, press the Stop button. The time will begin to flash in the display. To resume the workout, press the Start button or the Speed increase button. The walking belt will begin to move at the speed setting for the first segment of the workout. When the next segment of the workout begins, the treadmill will automatically adjust to the speed and incline settings for the next segment.

#### 6. Follow your progress with the displays.

See step 5 on pages 15 and 16.

The My Trail tab will show a map of the trail you are walking or running or it will show a track and the number of laps you are completing.

During a competition workout, the Compete tab will show your progress in the race. As you race, the top line in the matrix will show how much of the race you have completed. The other lines will show your top four competitors. The end of the matrix represents the end of the race.

#### 7. Measure your heart rate if desired.

See step 6 on page 16.

#### 8. When you are finished exercising, remove the key from the console.

See step 7 on page 16.

For more information on the iFit Live mode, go to [www.iFit.com](http://www.iFit.com).

### HOW TO USE THE STEREO SOUND SYSTEM

To play music or audio books through the console's stereo speakers, you must connect your MP3 player, CD player, or other personal audio player to the console through the MP3 jack.

To use the MP3 jack, locate the included audio wire and plug it into the MP3 jack. Then, plug the audio wire into a jack on your MP3 player, CD player, or other personal audio player. **Make sure that the audio wire is fully inserted.**

Next, press the Play button on your MP3 player, CD player, or other personal audio player. Adjust the volume on your personal audio player or press the volume increase and decrease buttons on the console.

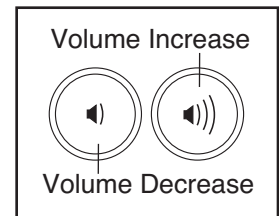

If you are using a personal CD player and the CD skips, set the CD player on the floor or another flat surface instead of on the console.

## THE INFORMATION MODE

The console features an information mode that keeps track of treadmill information and allows you to personalize console settings.

To select the information mode, hold down the Stop button while inserting the key into the console and then release the Stop button. When the information mode is selected, the following information will be shown:

The time display will show the total number of hours the treadmill has been used.

The distance display will show the total number of miles (or kilometers) that the walking belt has moved.

The lower section of the display will show the status of an iFit Live module. If a wireless iFit Live module is connected, the display will show the words WIFI MODULE. If a USB module is connected, the display will show the words USB/SD MODULE. If no module is connected, the display will show the words NO IFIT MODULE.

The matrix will show the selected unit of measurement. To change the unit of measurement, press the Enter button or the Speed increase button. To view distance in miles, select ENGLISH. To view distance in kilometers, select METRIC.

Press the decrease button next to the Enter button. The console features a display demo mode, designed to be used if the treadmill is displayed in a store. While the demo mode is turned on, the console will function normally when you plug in the power cord, press the power switch into the reset position, and insert the key into the console. However, when you remove the key, the displays will remain lit, although the buttons will not function. If the demo mode is turned on, the word ON will appear in the matrix. To turn on or turn off the

demo mode, press the Enter button or the Speed decrease button.

Press the decrease button next to the Enter button. The display will show the contrast level of the display. Press the Incline increase and decrease buttons to adjust the contrast.

If a wireless iFit Live module is connected, press the decrease button next to the Enter button to view the status of the personal trainer voice. To turn on or turn off the voice of the personal trainer, press the Enter button.

If a wireless iFit Live module is connected, press the decrease button next to the Enter button to view the default menu. The default menu will appear when you insert the key into the console or when you press the Home button. Press the Enter button repeatedly to select the manual mode main screen or the iFit Live main screen as the default menu.

If a wireless iFit Live module is connected, press the decrease button next to the Enter button to view the status of the iFit Live module. Press the Enter button to check the status of the iFit Live module. If a wireless iFit Live module is connected, the display will show the words WIFI STATUS. If a USB module is connected, the display will show the words USB STATUS. If no module is connected, the display will show the words NO MODULE DETECTED.

If a wireless iFit Live module is connected, press the decrease button next to the Enter button to transfer data. To send and receive workouts, workout logs, and updates, press the Enter button. When the process is finished, the words TRANSFERS DONE will appear in the display.

To exit the information mode, remove the key from the console.

# HOW TO FOLD AND MOVE THE TREADMILL

## HOW TO FOLD THE TREADMILL

To avoid damaging the treadmill, adjust the incline to the lowest position before you fold the treadmill. Then, remove the key and unplug the power cord. **CAUTION:** You must be able to safely lift 45 lbs. (20 kg) to raise, lower, or move the treadmill.

1. Hold the metal frame firmly in the location shown by the arrow below. **CAUTION:** Do not hold the frame by the plastic foot rails. Bend your legs and keep your back straight.

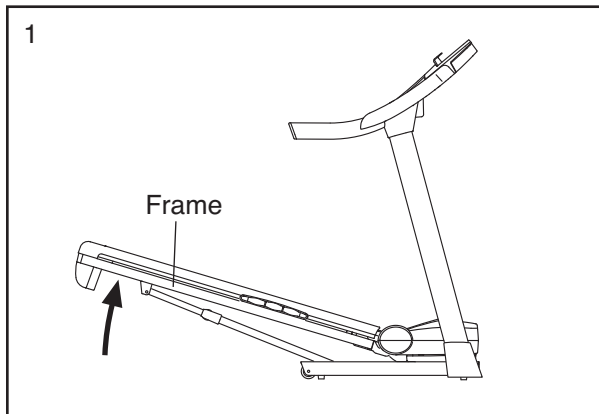

2. Raise the frame until the latch knob locks in the storage position. **CAUTION:** Make sure that the latch knob locks.

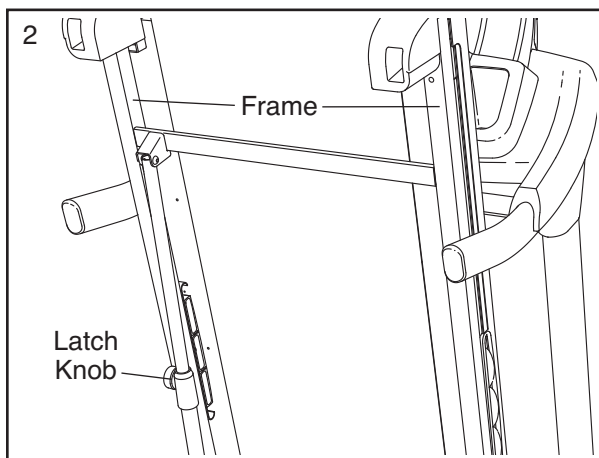

To protect the floor or carpet, place a mat under the treadmill. Keep the treadmill out of direct sunlight. Do not leave the treadmill in the storage position in temperatures above 85° F (30° C).

## HOW TO MOVE THE TREADMILL

Before moving the treadmill, fold it as described at the left. **CAUTION:** Make sure that the latch knob is locked in the storage position. Moving the treadmill may require two people.

1. Hold the frame and one of the handrails, and place one foot against a wheel.

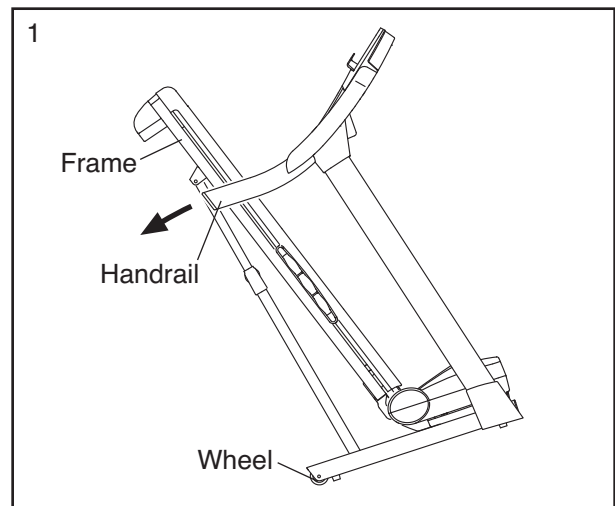

2. Pull back on the handrail until the treadmill will roll on the wheels, and carefully move it to the desired location. **CAUTION:** Do not move the treadmill without tipping it back, do not pull on the frame, and do not move the treadmill over an uneven surface.
3. Place one foot against a wheel, and carefully lower the treadmill.

## HOW TO LOWER THE TREADMILL FOR USE

1. **See drawing 2.** Hold the upper end of the treadmill frame with your right hand. Pull the latch knob to the left; if necessary, push the frame forward slightly. Pivot the frame downward a few inches, and release the latch knob.
2. **See drawing 1 at the left.** Hold the metal frame firmly with both hands, and lower it to the floor. **CAUTION:** Do not hold the frame by the plastic foot rails, and do not drop the frame. Bend your legs and keep your back straight.

# TROUBLESHOOTING

Most treadmill problems can be solved by following the simple steps below. Find the symptom that applies, and follow the steps listed. If further assistance is needed, see the front cover of this manual.

**PROBLEM: The power does not turn on**

**SOLUTION:** a. Make sure that the power cord is plugged into a surge suppressor, and that the surge suppressor is plugged into a properly grounded outlet (see page 13). Use only a single-outlet surge suppressor that meets all of the specifications described on page 13. **IMPORTANT: The treadmill is not compatible with GFCI-equipped outlets.**

b. After the power cord has been plugged in, make sure that the key is inserted into the console.

c. Check the power switch located on the treadmill frame near the power cord. If the switch protrudes as shown, the switch has tripped. To reset the switch, wait for five minutes and then press the switch back in.

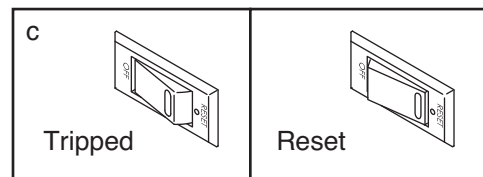

**PROBLEM: The power turns off during use**

**SOLUTION:** a. Check the power switch (see the drawing above). If the switch has tripped, wait for five minutes and then press the switch back in.

b. Make sure that the power cord is plugged in. If the power cord is plugged in, unplug it, wait for five minutes, and then plug it back in.

c. Remove the key from the console. Reinsert the key into the console.

d. If the treadmill still will not run, please see the front cover of this manual.

**PROBLEM: The console displays remain lit when you remove the key from the console**

**SOLUTION:** a. The console features a display demo mode, designed to be used if the treadmill is displayed in a store. If the displays remain lit when you remove the key, the demo mode is turned on. To turn off the demo mode, hold down the Stop button for a few seconds. If the displays are still lit, see THE INFORMATION MODE on page 20 to turn off the demo mode.

**PROBLEM: The displays of the console do not function properly**

**SOLUTION:** a. Remove the key from the console and **UNPLUG THE POWER CORD**. With the help of a second person, carefully tip down the Uprights (84, 85). There may be three #8 x 2" Screws (16) in the bottom of the Belly Pan (75). If there are, remove them. Note: A Phillips screwdriver with a shaft at least 5 in. (13 cm) long is required.

Then, raise the Uprights (84, 85).

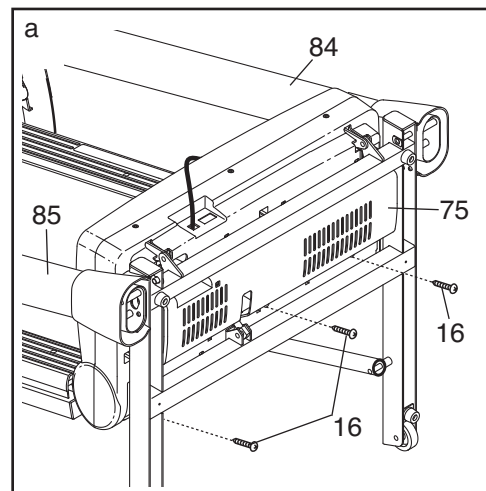

Remove the three #8 x 3/4" Screws (1) and carefully pivot the Motor Hood (62) off.

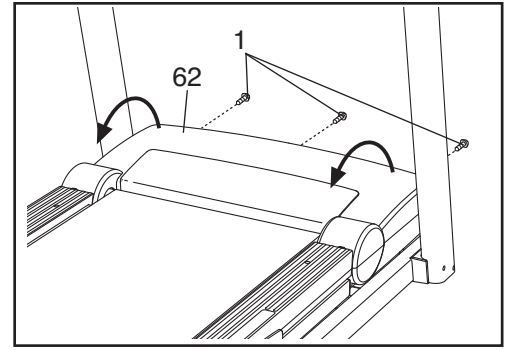

Locate the Reed Switch (73) and the Magnet (47) on the left side of the Pulley (48). Turn the Pulley until the Magnet is aligned with the Reed Switch. **Make sure that the gap between the Magnet and the Reed Switch is about 1/8 in. (3 mm).** If necessary, loosen the #8 x 3/4" Truss Head Screw (18), move the Reed Switch slightly, and then retighten the Screw. Reattach the Motor Hood (not shown) with the #8 x 3/4" Screws (not shown). Reattach the #8 x 2" Screws (not shown) if necessary. Run the treadmill for a few minutes to check for a correct speed reading.

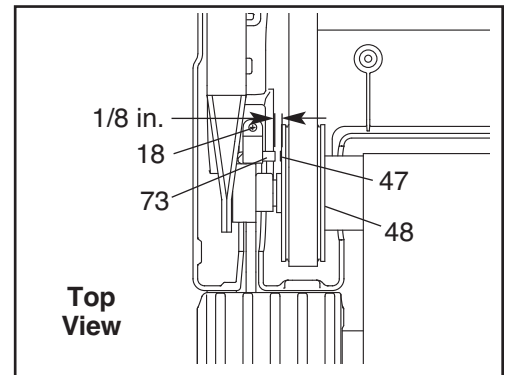

**PROBLEM: The incline of the treadmill does not change correctly**

**SOLUTION:** a. Hold down the Stop button and the Speed increase button, insert the key into the console, and then release the Stop button and the Speed increase button. Press the Stop button and then press the Incline increase or decrease button. The treadmill will automatically rise to the maximum incline level and then return to the minimum level. This will recalibrate the incline system. If the incline does not calibrate, press the Stop button again, and then press the Incline increase or decrease button again. When the incline is calibrated, remove the key from the console.

**PROBLEM: The walking belt slows when walked on**

**SOLUTION:** a. Use only a single-outlet surge suppressor that meets all of the specifications described on page 13.

b. If the walking belt is overtightened, treadmill performance may decrease and the walking belt may become damaged. Remove the key and **UNPLUG THE POWER CORD**. Using the hex key, turn both idler roller bolts counterclockwise, 1/4 of a turn. When the walking belt is properly tightened, you should be able to lift each edge of the walking belt 2 to 3 in. (5 to 7 cm) off the walking platform. Be careful to keep the walking belt centered. Then, plug in the power cord, insert the key, and run the treadmill for a few minutes. Repeat until the walking belt is properly tightened.

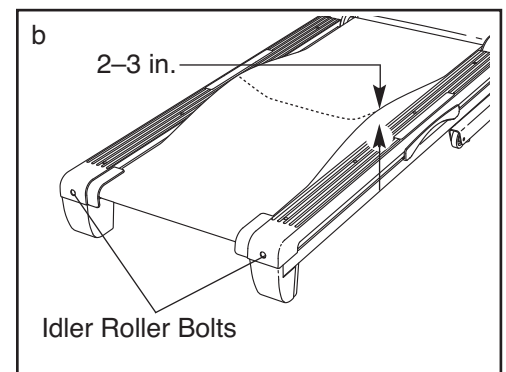

c. If the walking belt still slows when walked on, see the front cover of this manual.

**PROBLEM: The walking belt is off-center or slips when walked on**

**SOLUTION:** a. **If the walking belt is off-center**, first remove the key and **UNPLUG THE POWER CORD**. **If the walking belt has shifted to the left**, use the hex key to turn the left idler roller bolt clockwise 1/2 of a turn; **if the walking belt has shifted to the right**, turn the left idler roller bolt counterclockwise 1/2 of a turn. Be careful not to overtighten the walking belt. Then, plug in the power cord, insert the key, and run the treadmill for a few minutes. Repeat until the walking belt is centered.

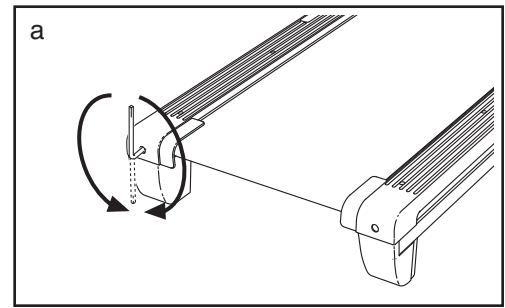

b. **If the walking belt slips when walked on**, first remove the key and **UNPLUG THE POWER CORD**. Using the hex key, turn both idler roller bolts clockwise, 1/4 of a turn. When the walking belt is correctly tightened, you should be able to lift each edge of the walking belt 2 to 3 in. (5 to 7 cm) off the walking platform. Be careful to keep the walking belt centered. Then, plug in the power cord, insert the key, and carefully walk on the treadmill for a few minutes. Repeat until the walking belt is properly tightened.

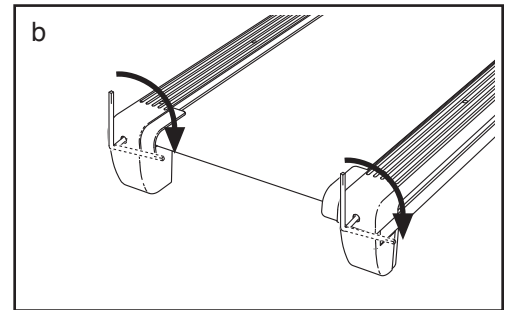

**PROBLEM: The console display has lines running through it**

**SOLUTION:** a. If lines appear in the console display, see THE INFORMATION MODE on page 20 and adjust the contrast level of the display.

# EXERCISE GUIDELINES

**⚠️ WARNING:** Before beginning this or any exercise program, consult your physician. This is especially important for persons over age 35 or persons with pre-existing health problems.

The pulse sensor is not a medical device. Various factors may affect the accuracy of heart rate readings. The pulse sensor is intended only as an exercise aid in determining heart rate trends in general.

These guidelines will help you to plan your exercise program. For detailed exercise information, obtain a reputable book or consult your physician. Remember, proper nutrition and adequate rest are essential for successful results.

## EXERCISE INTENSITY

Whether your goal is to burn fat or to strengthen your cardiovascular system, exercising at the proper intensity is the key to achieving results. You can use your heart rate as a guide to find the proper intensity level. The chart below shows recommended heart rates for fat burning and aerobic exercise.

165	155	145	140	130	125	115	♥
145	138	130	125	118	110	103	♥
125	120	115	110	105	95	90	♥
<hr/>							
20	30	40	50	60	70	80	

To find the proper intensity level, find your age at the bottom of the chart (ages are rounded off to the nearest ten years). The three numbers listed above your age define your “training zone.” The lowest number is the heart rate for fat burning, the middle number is the heart rate for maximum fat burning, and the highest number is the heart rate for aerobic exercise.

**Burning Fat**—To burn fat effectively, you must exercise at a low intensity level for a sustained period of time. During the first few minutes of exercise, your body uses *carbohydrate calories* for energy. Only after the first few minutes of exercise does your body begin to use stored *fat calories* for energy. If your goal is to burn fat, adjust the intensity of your exercise until your heart rate is near the lowest number in your training zone. For maximum fat burning, exercise with your heart rate near the middle number in your training zone.

**Aerobic Exercise**—If your goal is to strengthen your cardiovascular system, you must perform aerobic exercise, which is activity that requires large amounts of oxygen for prolonged periods of time. For aerobic exercise, adjust the intensity of your exercise until your heart rate is near the highest number in your training zone.

## WORKOUT GUIDELINES

**Warming Up**—Start with 5 to 10 minutes of stretching and light exercise. A warm-up increases your body temperature, heart rate, and circulation in preparation for exercise.

**Training Zone Exercise**—Exercise for 20 to 30 minutes with your heart rate in your training zone. (During the first few weeks of your exercise program, do not keep your heart rate in your training zone for longer than 20 minutes.) Breathe regularly and deeply as you exercise—never hold your breath.

**Cooling Down**—Finish with 5 to 10 minutes of stretching. Stretching increases the flexibility of your muscles and helps to prevent post-exercise problems.

## EXERCISE FREQUENCY

To maintain or improve your condition, complete three workouts each week, with at least one day of rest between workouts. After a few months of regular exercise, you may complete up to five workouts each week, if desired. Remember, the key to success is to make exercise a regular and enjoyable part of your everyday life.

# PART LIST—Model No. PFTL60910.1

R0910A

To locate the parts listed below, see the EXPLODED DRAWING near the end of this manual.

Key No.	Qty.	Description	Key No.	Qty.	Description
1	34	#8 x 3/4" Screw	51	1	Storage Latch
2	4	#10 x 3/4" Screw	52	2	Console Ground Wire
3	4	5/16" x 1" Flat Head Patch Bolt	53	4	#8 x 1" Screw
4	2	5/16" x 1" Patch Bolt	54	1	Right Foot Rail
5	4	#8 x 1" Tek Screw	55	1	Frame
6	1	3/8" x 1 3/4" Patch Bolt	56	2	Roller Bracket
7	4	3/8" x 4" Patch Bolt	57	1	Roller Ground Wire
8	3	3/8" x 2" Bolt	58	1	Right Rear Foot
9	4	1/4" x 1" Patch Bolt	59	1	Left Rear Foot
10	3	3/8" Nut	60	1	Idler Roller
11	6	3/8" Star Washer	61	1	Hex Key
12	8	#10 Star Washer	62	1	Motor Hood
13	2	5/16" Star Washer	63	1	Hood Accent
14	2	3/8" x 1 1/2" Patch Bolt	64	1	Lift Frame
15	5	#8 x 3/4" Tek Screw	65	1	Lift Frame Ground Wire
16	3	#8 x 2" Screw	66	1	Drive Motor Belt
17	2	#8 x 1/2" Pan Head Screw	67	1	Drive Motor
18	11	#8 x 3/4" Truss Head Screw	68	1	Controller Ground Wire
19	2	#8 x 1 1/2" Screw	69	1	Power Cord
20	2	5/16" x 1 1/2" Bolt	70	1	Grommet
21	2	5/16" x 3 5/8" Bolt	71	1	Power Switch
22	2	3/8" x 1" Patch Bolt	72	1	Controller
23	1	1/4" x 1" Bolt	73	1	Reed Switch
24	2	Idler Roller Bolt	74	1	Reed Switch Clamp
25	1	3/8" x 1 3/4" Bolt	75	1	Belly Pan
26	1	3/8" x 1 1/2" Bolt	76	3	Wire Tie
27	2	3/8" x 3/4" Bolt	77	8	8" Tie
28	7	#8 x 1/2" Bright Screw	78	2	15" Tie
29	1	#8 x 1/2" Ground Screw	79	4	Releasable Tie
30	8	#12 x 1 1/4" Screw	80	1	Left Upright Cover
31	2	1/4" Motor Bolt	81	2	Handrail Cap
32	4	#8 Belt Guide Screw	82	1	Left Handrail
33	2	1/4" Washer	83	1	Right Handrail
34	2	1/4" Split Washer	84	1	Left Upright
35	4	3/8" Jam Nut	85	1	Right Upright
36	4	5/16" Flange Nut	86	1	Right Upright Cover
37	3	Hood Clip	87	1	Upright Wire
38	2	5/16" Cage Nut	88	1	Left Base Cover
39	2	Foot Rail Decal	89	2	Base Cap
40	1	Left Foot Rail	90	4	Base Foot
41	1	Latch Warning Decal	91	1	Right Base Cover
42	2	Platform Cushion	92	2	Caution Decal
43	2	Belt Guide	93	1	Incline Wire
44	1	Walking Platform	94	2	Base Foot Spacer
45	2	Frame Cap	95	1	Base
46	2	Frame Spacer	96	2	Wheel
47	1	Magnet	97	1	Incline Motor
48	1	Front Roller/Pulley	98	1	Incline Motor Spacer
49	1	Walking Belt	99	1	Key/Clip
50	1	Audio Wire	100	3	Cable Tie

<b>Key No.</b>	<b>Qty.</b>	<b>Description</b>	<b>Key No.</b>	<b>Qty.</b>	<b>Description</b>
101	1	Console	106	1	Console Base
102	1	Console Frame	107	1	Crossbar
103	1	Tray	108	1	Access Door
104	1	5/32" Hex Key	109	4	1/4" Star Washer
105	2	Console Clamp	*	–	User's Manual

Note: Specifications are subject to change without notice. For information about ordering replacement parts, see the back cover of this manual. \*These parts are not illustrated.

# EXPLODED DRAWING A—Model No. PFTL60910.1

R0910A

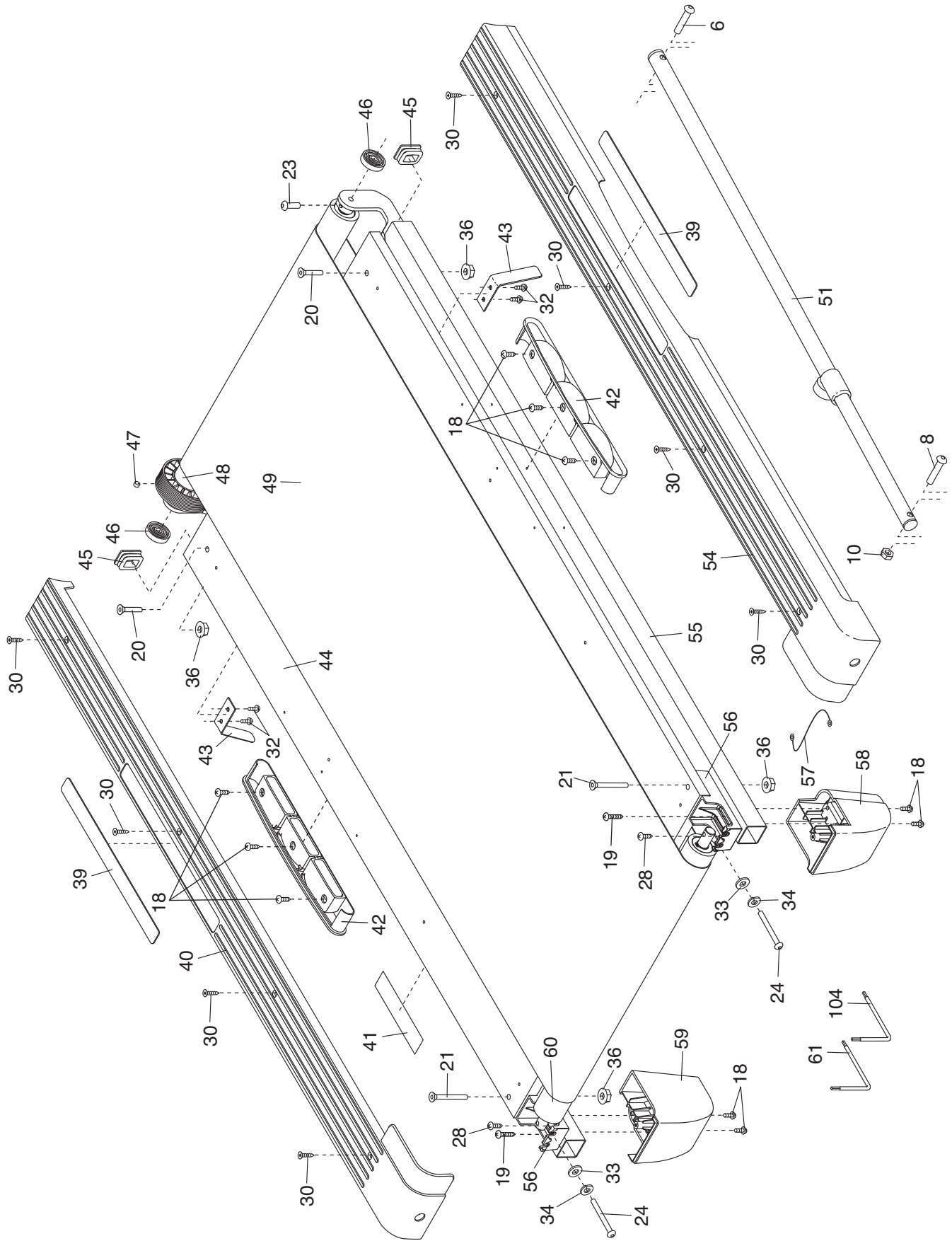

# EXPLODED DRAWING B—Model No. PFTL60910.1

R0910A

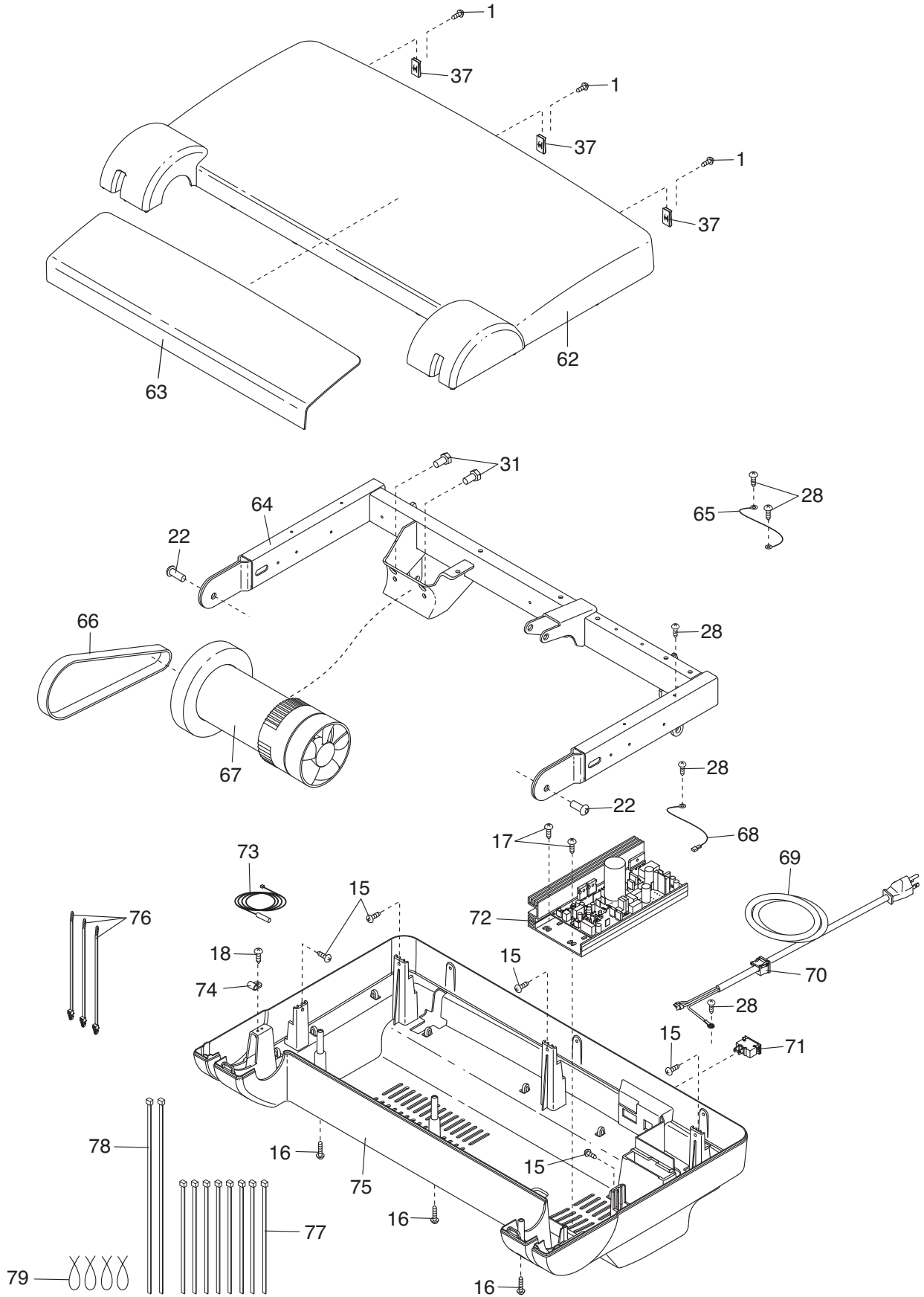

# EXPLODED DRAWING C—Model No. PFTL60910.1

R0910A

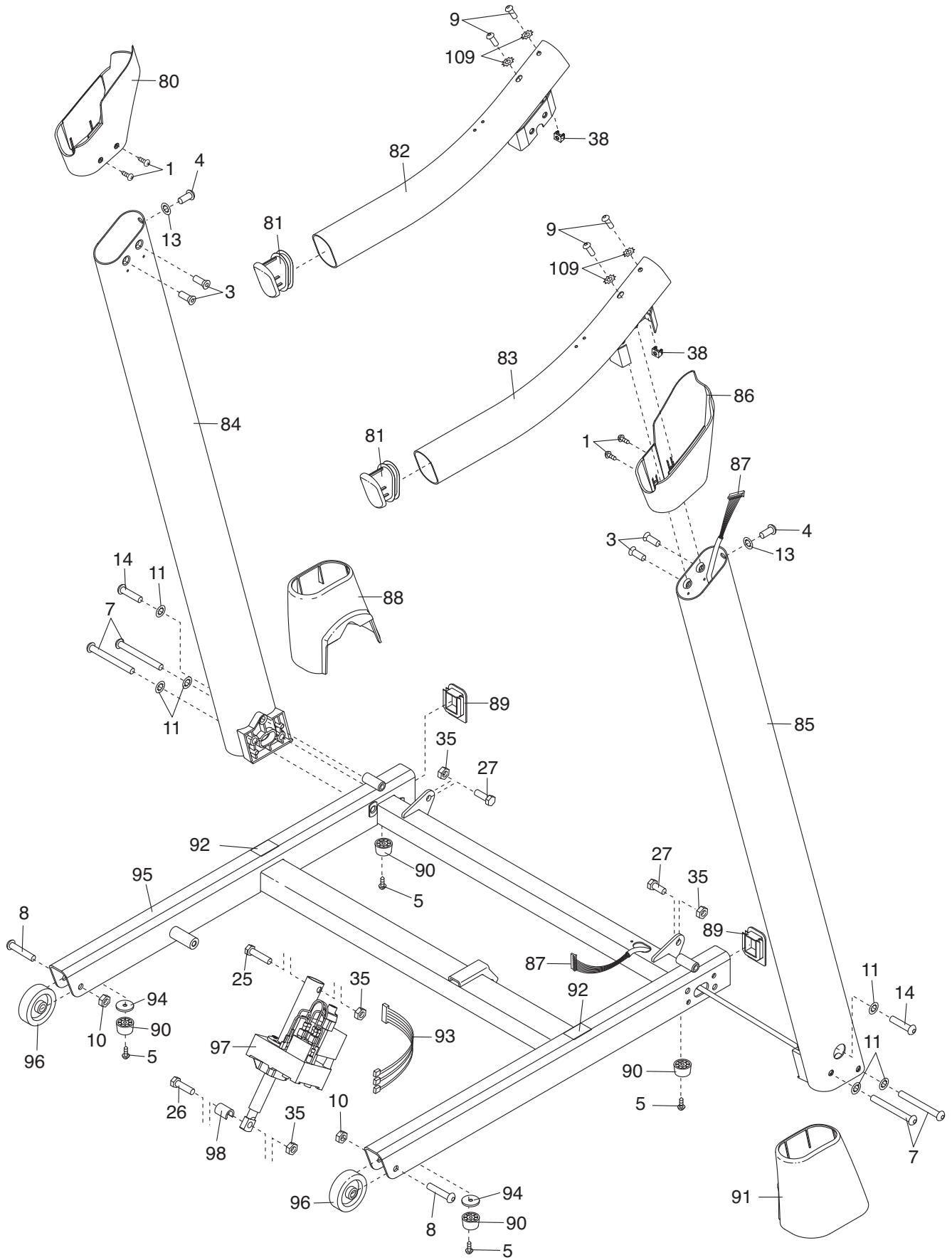

# EXPLODED DRAWING D—Model No. PFTL60910.1

R0910A

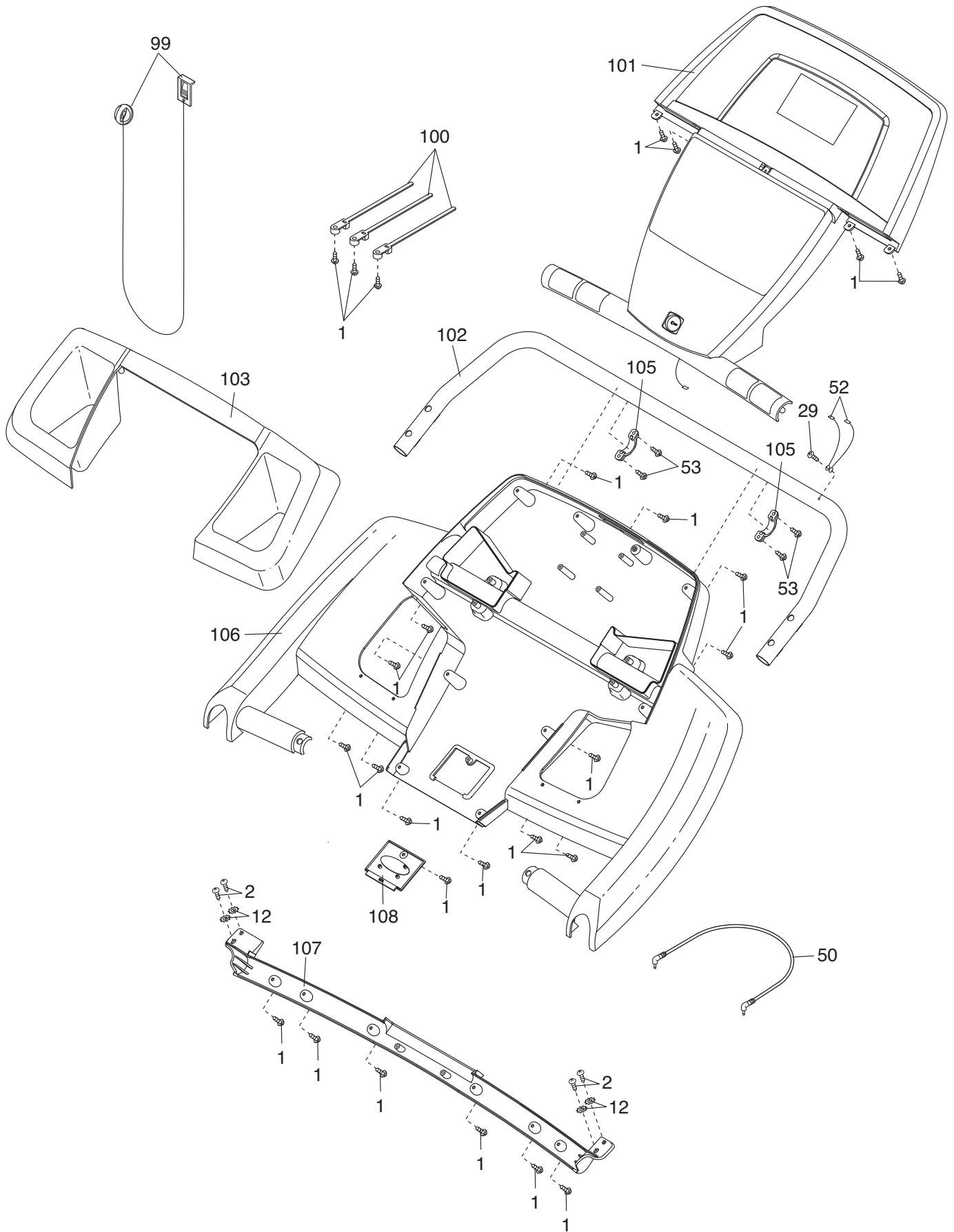

# ORDERING REPLACEMENT PARTS

To order replacement parts, please see the front cover of this manual. To help us assist you, be prepared to provide the following information when contacting us:

- the model number and serial number of the product (see the front cover of this manual)
- the name of the product (see the front cover of this manual)
- the key number and description of the replacement part(s) (see the PART LIST and the EXPLODED DRAWING near the end of this manual)

## LIMITED WARRANTY

**IMPORTANT: You must register this product within 30 days of the purchase date to avoid added fees for service needed under warranty. Go to [www.proformservice.com/registration](http://www.proformservice.com/registration).**

ICON Health & Fitness, Inc. (ICON) warrants this product to be free from defects in workmanship and material, under normal use and service conditions. The frame is warranted for a lifetime. The drive motor is warranted for twenty-five (25) years from the date of purchase. Parts and labor are warranted for one (1) year from the date of purchase.

This warranty extends only to the original purchaser. ICON's obligation under this warranty is limited to repairing or replacing, at ICON's option, the product through one of its authorized service centers. All repairs for which warranty claims are made must be preauthorized by ICON. If the product is shipped to a service center, freight charges to and from the service center will be the customer's responsibility. For replacement parts shipped while the product is under warranty, the customer will be responsible for a minimal handling charge. For in-home service, the customer will be responsible for a minimal trip charge. This warranty does not extend to any damage to a product caused by or attributable to freight damage, abuse, misuse, improper or abnormal usage, or repairs not provided by an ICON authorized service center; to products used for commercial or rental purposes or as store display models; or to products transported or purchased outside the US. No other warranty beyond that specifically set forth above is authorized by ICON.

ICON is not responsible or liable for indirect, special, or consequential damages arising out of or in connection with the use or performance of the product; damages with respect to any economic loss, loss of property, loss of revenues or profits, loss of enjoyment or use, or costs of removal or installation; or other consequential damages of whatsoever nature. Some states do not allow the exclusion or limitation of incidental or consequential damages. Accordingly, the above limitation may not apply to you.

The warranty extended hereunder is in lieu of any and all other warranties, and any implied warranties of merchantability or fitness for a particular purpose are limited in their scope and duration to the terms set forth herein. Some states do not allow limitations on how long an implied warranty lasts. Accordingly, the above limitation may not apply to you.

This warranty gives you specific legal rights. You may also have other rights that vary from state to state.

**ICON Health & Fitness, Inc., 1500 S. 1000 W., Logan, UT 84321-9813**