

PRO-FORM

PERFORMANCE TREADMILL

625ex
WIDE DECK

Model No. PCTL62590

Serial No. _____

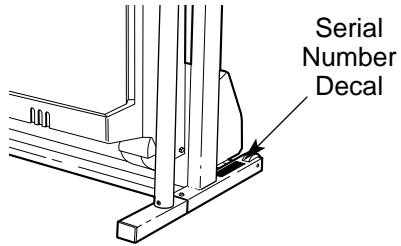

USER'S MANUAL

QUESTIONS?

As a manufacturer, we are committed to providing complete customer satisfaction. If you have questions, or if there are missing parts, please call:

1-888-936-4266

Mon.–Fri. 8h00 until 18h30 EST
(excluding holidays).

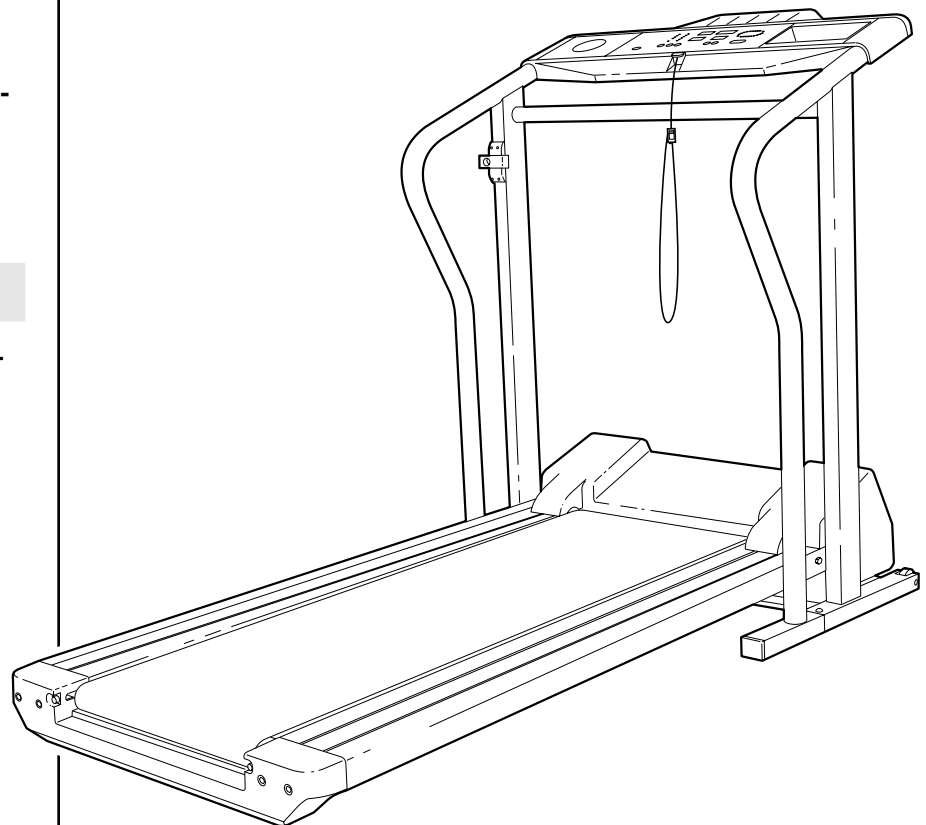

⚠ CAUTION

Read all precautions and instructions in this manual before using this equipment. Save this manual for future reference.



Visit our website at

www.proform.com

TABLE OF CONTENTS

IMPORTANT PRECAUTIONS	2
BEFORE YOU BEGIN	4
ASSEMBLY	5
OPERATION AND ADJUSTMENT	7
HOW TO FOLD AND MOVE THE TREADMILL	11
MAINTENANCE AND TROUBLE-SHOOTING	12
CONDITIONING GUIDELINES	14
ORDERING REPLACEMENT PARTS	15
LIMITED WARRANTY	Back Cover

Note: An EXPLODED DRAWING and PART LIST are attached in the center of this manual. Save them for future reference.

IMPORTANT PRECAUTIONS

⚠ WARNING: To reduce the risk of burns, fire, electric shock, or injury to persons, read the following important precautions and information before operating the treadmill.

1. It is the responsibility of the owner to ensure that all users of this treadmill are adequately informed of all warnings and precautions.
2. Use the treadmill only as described in this manual.
3. Place the treadmill on a level surface, with at least 2 m (8 ft.) of clearance behind it. Do not place the treadmill on any surface that blocks air openings. To protect the floor or carpet from damage, place a mat under the treadmill.
4. Keep the treadmill indoors, away from moisture and dust. Do not put the treadmill in a garage or covered patio, or near water.
5. Do not operate the treadmill where aerosol products are used or where oxygen is being administered.
6. Keep children under the age of 12 and pets away from the treadmill at all times.
7. The treadmill should not be used by persons weighing more than 115 kg (250 lbs.).
8. Never allow more than one person on the treadmill at a time.
9. Wear appropriate exercise clothing when using the treadmill. Do not wear loose clothing that could become caught in the treadmill. Athletic support clothes are recommended for both men and women. *Always wear athletic shoes. Never use the treadmill with bare feet, wearing only stockings, or in sandals.*
10. When connecting the power cord (see page 8), plug the power cord into a surge suppressor (not included) and plug the surge suppressor into a grounded circuit capable of carrying 15 or more amps. No other appliance should be on the same circuit. Do not use an extension cord.
11. Use only a CUL-listed surge suppressor of 450 joules minimum surge dissipation with voltage rating of 400 volts or less, rated at 15 amps, with a (1 mm²)14-gauge cord of 1,5 m (5 ft.) or less in length. Do not use an extension cord.
12. Keep the power cord and the surge suppressor away from heated surfaces.
13. Never move the walking belt while the power is turned off. Do not operate the treadmill if the power cord or plug is damaged, or if the treadmill is not working properly. (See BEFORE YOU BEGIN on page 4 if the treadmill is not working properly.)

14. Never start the treadmill while you are standing on the walking belt. Always hold the handrails while using the treadmill.
15. The treadmill is capable of high speeds. Adjust the speed in small increments to avoid sudden jumps in speed.
16. The pulse sensor is not a medical device. Various factors, including the user's movement, may affect the accuracy of heart rate readings. The pulse sensor is intended only as an exercise aid in determining heart rate trends in general.
17. To reduce the possibility of the treadmill overheating, do not operate the treadmill continuously for longer than 1 hour.
18. Never leave the treadmill unattended while it is running. Always remove the key, unplug the power cord and move the on/off switch to the off position when the treadmill is not in use. (See the drawing on page 4 for the location of the on/off switch.)
19. Do not attempt to raise, lower, or move the treadmill until it is properly assembled. (See ASSEMBLY on page 5, and HOW TO FOLD AND MOVE THE TREADMILL on page 11.)

You must be able to safely lift 20 kg (45 lbs.) in order to raise, lower, or move the treadmill.

20. Do not change the incline of the treadmill by placing objects under the treadmill.
21. When folding or moving the treadmill, make sure that the storage latch is fully closed.
22. Inspect and tighten all parts of the treadmill regularly.
23. Never drop or insert any object into any opening.
24. **DANGER:** Always unplug the power cord immediately after use, before cleaning the treadmill, and before performing the maintenance and adjustment procedures described in this manual. Never remove the motor hood unless instructed to do so by an authorized service representative. Servicing other than the procedures in this manual should be performed by an authorized service representative only.
25. This treadmill is intended for in-home use only. Do not use this treadmill in any commercial, rental, or institutional setting.

⚠ WARNING: Before beginning this or any exercise program, consult your physician. This is especially important for persons over the age of 35 or persons with pre-existing health problems. Read all instructions before using. ICON assumes no responsibility for personal injury or property damage sustained by or through the use of this product.

SAVE THESE INSTRUCTIONS

The decal shown has been placed on your treadmill. If the decal is missing, or if it is not legible, please call our Customer Service Department, toll-free, to order a free replacement decal (see ORDERING REPLACEMENT PARTS on the back cover of this manual). Apply the decal in the location shown.

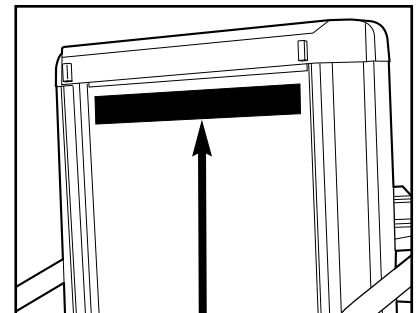

⚠ WARNING: Protect yourself and others from risk of serious injury. Read the user's manual and:

- Fully engage storage latch before treadmill is moved or stored.
- Reduce incline to lowest level before folding treadmill into storage position.



- Stand only on side rails when starting or stopping treadmill.
- Change speed in small increments.
- Hold handrails to prevent falling, and always wear the safety clip while operating treadmill.
- Stop if you feel faint, dizzy, or short of breath.



- Never allow children on or around treadmill.
- Remove key when not in use.



- Keep clothing, fingers, and hair away from moving belt.
- Never try to adjust or fix the belt while it is moving.
- Always wear athletic shoes while operating treadmill.

BEFORE YOU BEGIN

Thank you for selecting the PROFORM® 625EX treadmill. The 625EX treadmill combines advanced technology with innovative design to let you enjoy an excellent form of cardiovascular exercise in the convenience and privacy of your home. And when you're not exercising, the unique 625EX can be folded up, requiring less than half the floor space of other treadmills.



For your benefit, read this manual carefully before using the treadmill. If you have additional questions, please call our Customer Service Department toll-free

at **1-888-936-4266**, Monday through Friday, 8h00 until 18h00 Eastern Time (excluding holidays). To help us assist you, please note the product model number and serial number before calling. The model number of the treadmill is PCTL62590. The serial number can be found on a decal attached to the treadmill (see the front cover of this manual for the location).

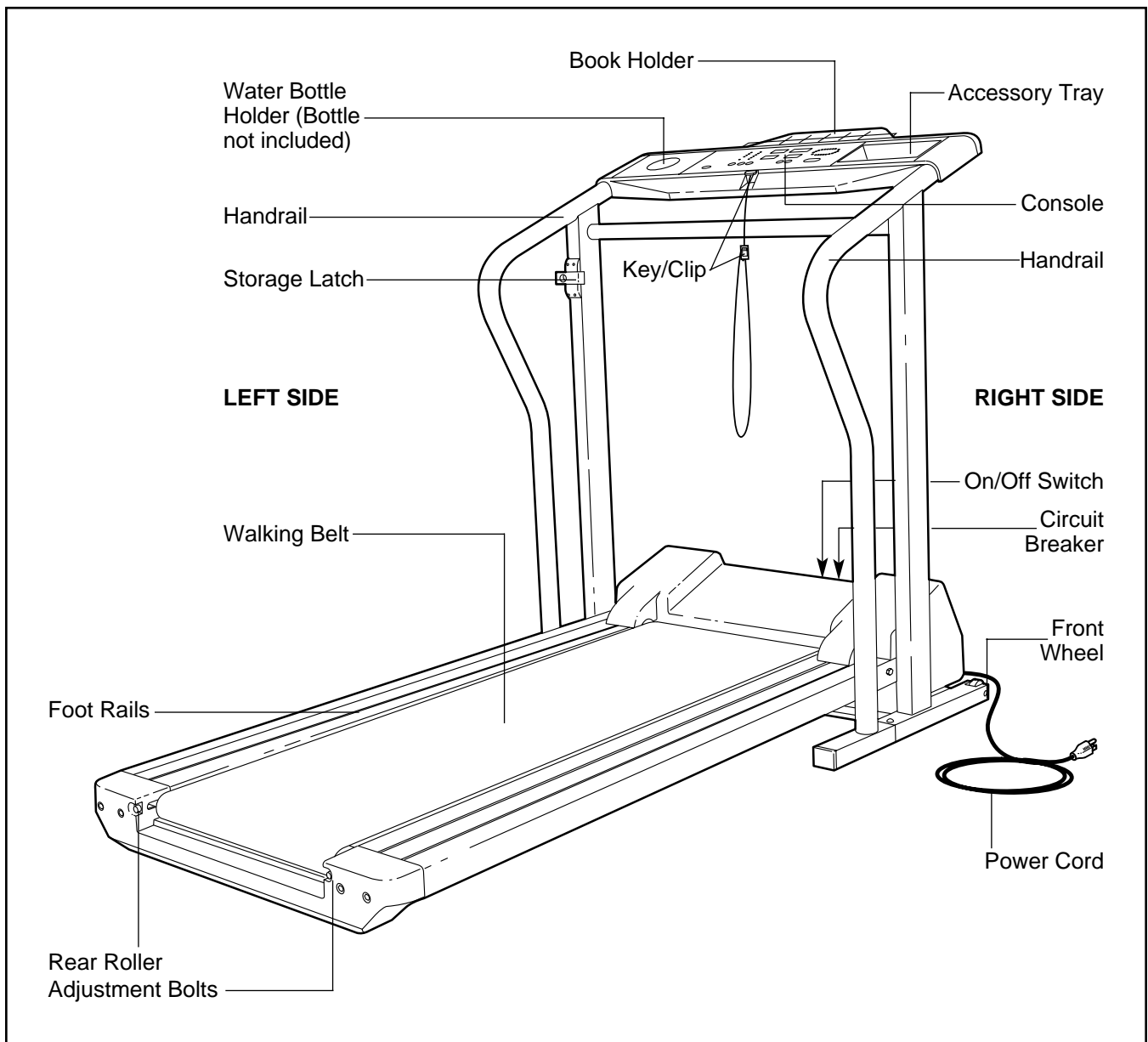
Before reading further, please review the drawing below and familiarize yourself with the labeled parts.

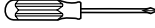

ASSEMBLY

Assembly requires two people. Set the treadmill in a cleared area and remove all packing materials. Do not dispose of the packing materials until assembly is completed. **Assembly requires the included allen wrench and your own phillips screwdriver** , **adjustable wrench** , and **scissors** .

1. With the help of a second person, carefully raise the treadmill to the upright position. While a second person tips the treadmill to one side slightly and holds it, insert one of the Extension Legs (59) into the base of the Uprights (32) as shown. Make sure that the Extension Leg is turned so the bracket is on top. Using the Allen Wrench (102), tighten one of the two Extension Leg Screws (57) into the Base and the Extension Leg. Next, tip the treadmill to the other side and attach the other Extension Leg in the same way.

With the help of a second person, carefully lower the treadmill so that both Extension Legs (59) are resting flat on the floor.

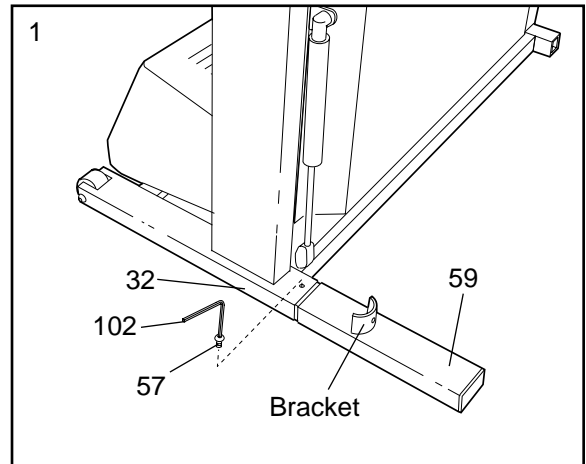

2. Refer to HOW TO LOWER THE TREADMILL FOR USE on page 11. Follow the instructions in step 2 to lower the treadmill.

Without removing the tape from the Latch (34), hold the Latch against the left Upright (32) as shown. Attach the Latch to the left Upright with four Catch Screws (33). **Make sure that the Screws are tight, but do not overtighten them; if the Screws are overtightened, the Latch will not slide smoothly.** After the Latch is attached, remove any visible tape.

Note: The inset drawing shows how the parts of the Latch (34) fit together.

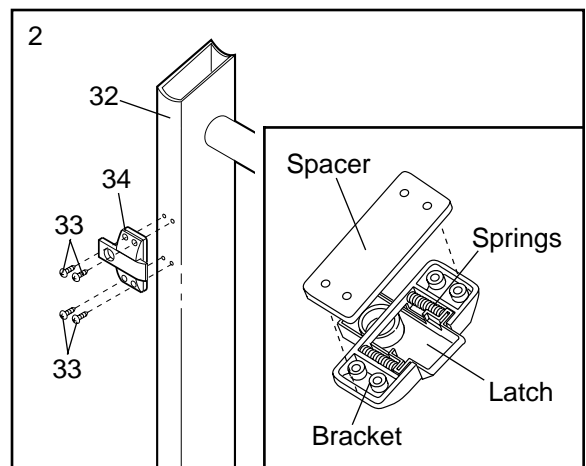

3. Cut the plastic tie holding the cage nut in the upper end of the Left Handrail (60).

Position the Left Handrail (60) on the left Upright (32) as shown. The bracket on the Extension Leg (59) should be **inside** of the lower end of the Left Handrail. Thread a Handrail Bolt (30) with a Handrail Washer (31) into the left Upright and the Left Handrail. **Do not tighten the Handrail Bolt yet.**

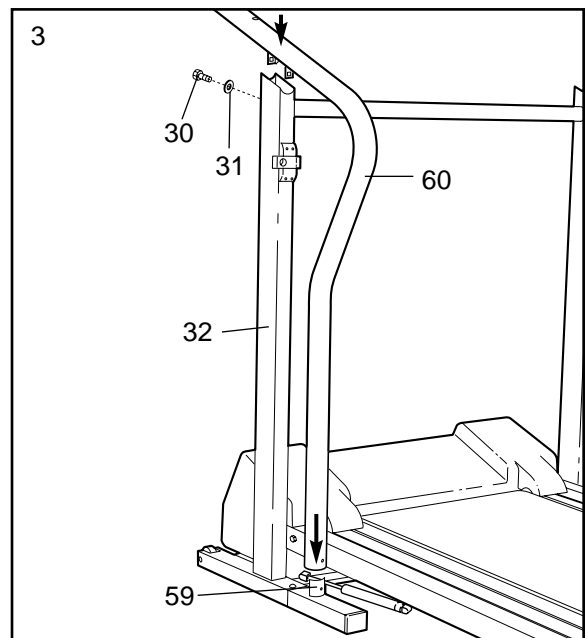

- Cut the indicated plastic tie off the Right Handrail (62). Feed the large wire tie and the Console Wire Harness (90) into the Right Handrail and out through the indicated bracket. Pull as much of the Console Wire Harness through the Right Handrail as possible. Note: It may be helpful to turn the Console over on a flat surface as you do this.

Next, rest the left side of the Console Base (46) on the Left Handrail (not shown). While a second person holds the Console Base and the Right Handrail (62) in the position shown, cut the plastic tie holding the Wire Harness (35) in the right Upright (32). **Note: Be careful not to drop the Wire Harness into the right Upright.**

Next, connect the Wire Harness (35) to the Console Wire Harness (90) (refer to the inset drawing). The latch on the Wire Harness should snap onto the Console Wire Harness. **If the Wire Harnesses do not fit together easily, turn them; do not force them together.** Remove the large wire tie from the Console Wire Harness and insert the slack Wire Harness into the Right Upright (32).

Refer to step 3 on page 5 and attach the Right Handrail (62) as described. **Be careful to avoid damaging the wires in the Right Handrail.**

- Make sure that the Console Base (46) is on the Handrails (60, 62). Route the Console Wire Harness (90) up into the Console Base as shown. Insert any slack into the Right Handrail (62).

Attach the Console Base (46) to the Handrails (60, 62) with four Handrail Mounting Screws (24).

- Refer to HOW TO FOLD THE TREADMILL FOR STORAGE on page 11. Follow the instructions in step 2 to fold the treadmill.

Attach the lower end of the Right Handrail (62) to the right Extension Leg (59) with a Latch Screw (33). Attach the lower end of the Left Handrail (60) in the same way.

Tighten all parts used in steps 3, 4, 5 and 6.

- Remove the backing from the Adhesive Clip (101). Press the Adhesive Clip onto the base of the right Upright (32) as shown. Press the Allen Wrench (102) into the Adhesive Clip.

- Make sure that all parts are tightened before you use the treadmill.** To protect the floor or carpet, place a mat under the treadmill.

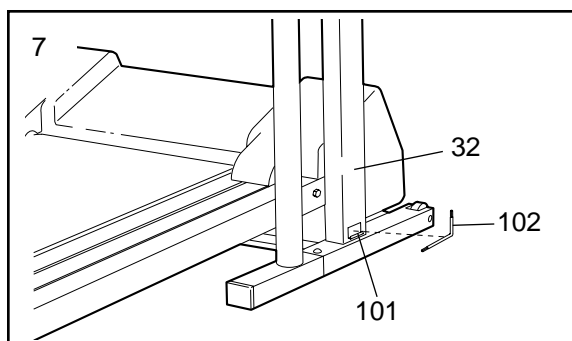
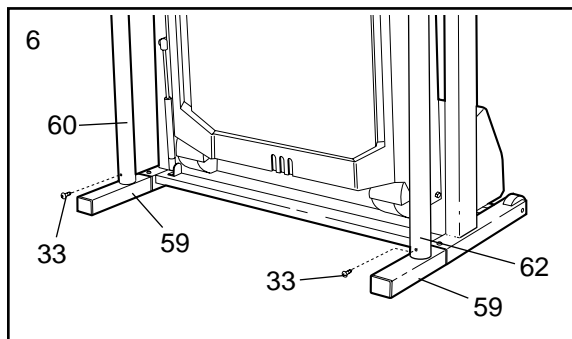
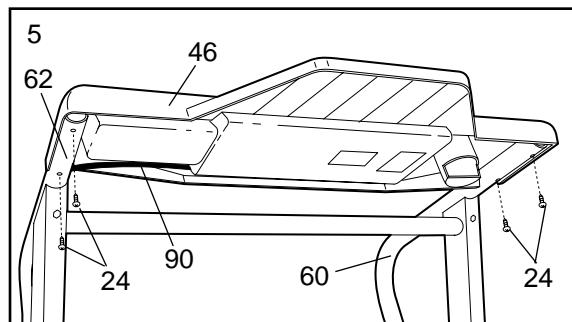
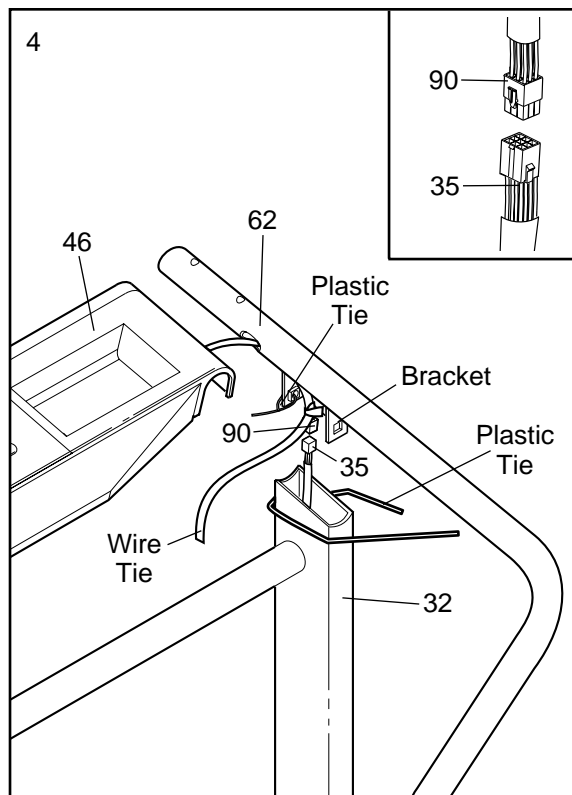

OPERATION AND ADJUSTMENT

THE PERFORMANT LUBE™ WALKING BELT

Your treadmill features a walking belt coated with PERFORMANT LUBE™, a high-performance lubricant.

IMPORTANT: Never apply silicone spray or other substances to the walking belt or the walking platform. Such substances will deteriorate the walking belt and cause excessive wear.

HOW TO PLUG IN THE POWER CORD

⚠ DANGER: Improper connection of the equipment-grounding conductor can result in an increased risk of electric shock. Check with a qualified electrician or serviceman if you are in doubt as to whether the product is properly grounded. Do not modify the plug provided with the product—if it will not fit the outlet, have a proper outlet installed by a qualified electrician.

Your treadmill, like any other type of sophisticated electronic equipment, can be seriously damaged by sudden voltage changes in your home's power. Voltage surges, spikes, and noise interference can result from weather conditions or from other appliances being turned on or off.

To decrease the possibility of your treadmill being damaged, always use a surge suppressor with your treadmill (see drawing 1 at the right).

Surge suppressors are sold at most hardware stores and department stores. Use only a CUL-listed surge suppressor with 450 joules minimum surge dissipation rated at 15 amps, with a 1mm² (14-gauge) cord of five feet or less in length.

This product must be grounded. If it should malfunction or break down, grounding pro-

vides a path of least resistance for electric current to reduce the risk of electric shock. This product is equipped with a cord having an equipment-grounding conductor and a grounding plug. **Plug the power cord into a surge suppressor, and plug the surge suppressor into an appropriate outlet that is properly installed and grounded in accordance with all local codes and ordinances.**

This product is for use on a nominal 120-volt circuit, and has a grounding plug that looks like the plug illustrated in drawing 1 below. A temporary adapter that looks like the adapter illustrated in drawing 2 may be used to connect the surge suppressor to a 2-pole receptacle as shown in drawing 2 if a properly grounded outlet is not available.

The temporary adapter should be used only until a properly grounded outlet (drawing 1) can be installed by a qualified electrician.

The green-colored rigid ear, lug, or the like extending from the adapter must be connected to a permanent ground such as a properly grounded outlet box cover. Whenever the adapter is used it must be held in place by a metal screw. **Some 2-pole receptacle outlet box covers are not grounded. Contact a qualified electrician to determine if the outlet box cover is grounded before using an adapter.**

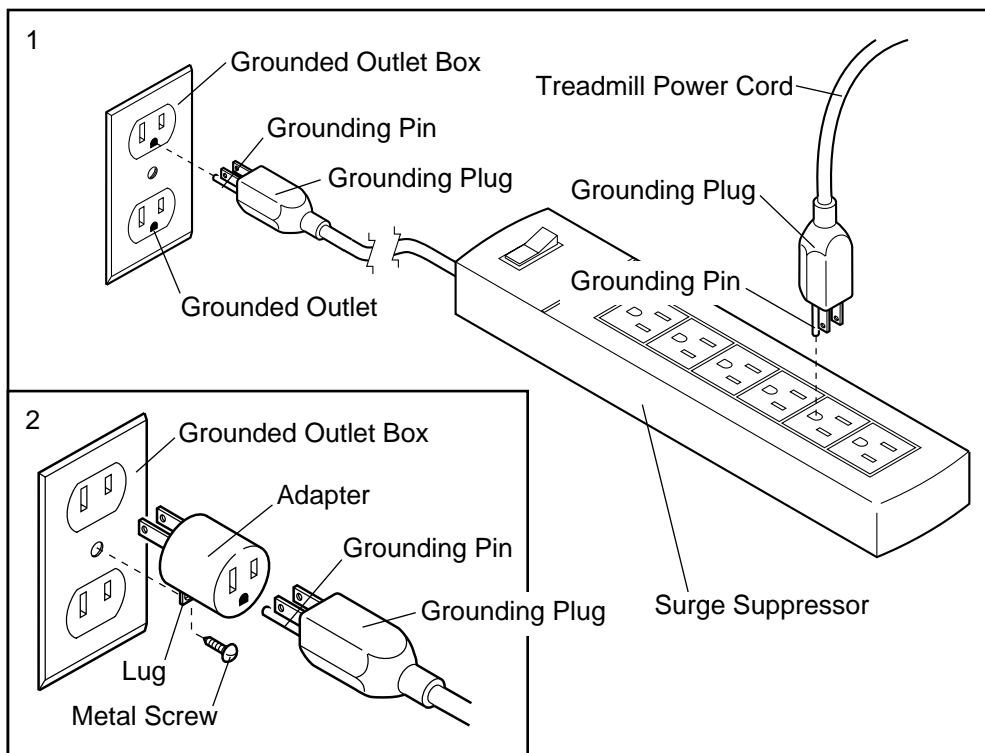

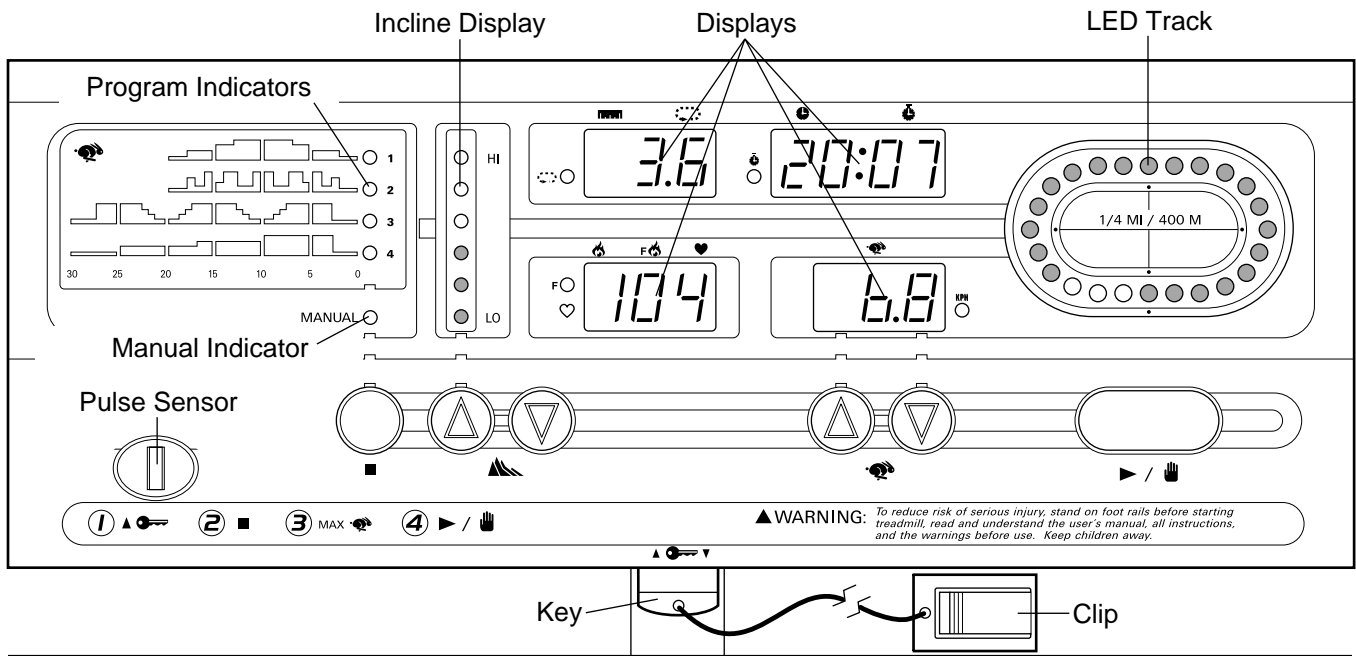

CAUTION: Before operating the console, read the following precautions.

- Do not stand on the walking belt when turning on the power.
- Always wear the clip while operating the treadmill.
- Adjust the speed in small increments.
- To reduce the possibility of electric shock, keep the console dry. Avoid spilling liquids on the console, and use only a sealed water bottle.

STEP-BY-STEP CONSOLE OPERATION

The console features a manual mode and four workout programs. When the manual mode is selected, the speed and incline of the treadmill can be changed with a touch of a button. As you exercise, the LED track and the four displays will provide continuous exercise feedback—you can even measure your heart rate with the built-in pulse sensor. When one of the workout programs is selected, the console will automatically control the speed as it guides you through an effective workout.

Before operating the console, make sure that the on/off switch near the power cord is in the on position.

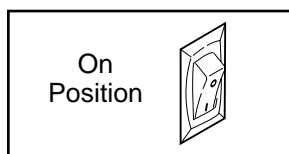

Next, make sure that the key is removed from the console, and plug in the power cord (see HOW TO PLUG

IN THE POWER CORD on page 7). **Note:** If the key is in the console when the power cord is plugged in, the letters “PO” will flash in the SPEED display. If this occurs, remove the key.

Step onto the foot rails of the treadmill. Find the clip attached to the key (see the drawing above), and slide the clip onto the waistband of your clothing.

Follow the steps below to operate the console. Note: If there is a thin sheet of clear plastic on the face of the console, remove it.

- 1 Insert the key fully into the console.**
When the key is inserted, various indicators and displays on the console will light.

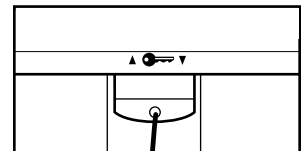

- 2 Press the MODE button to select the desired mode.**

When the key is inserted, the manual mode will be selected and the MANUAL indicator will be lit. Note: If a workout program has been selected, press the MODE button repeatedly to select the manual mode.

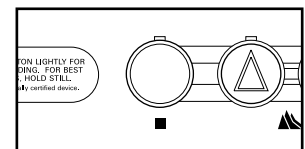

If you want to select one of the four workout programs, press the MODE button. The upper program indicator will light. To select one of the other three programs, press the MODE button repeatedly.

Note: There are two twenty-minute programs and two thirty-minute programs. The graphs on the left side of the console show how the speed of the walking belt will change during the programs. During the program 1, for example, the speed will gradually increase during the first ten minutes, and then gradually decrease during the last ten minutes. Each program begins with a warm-up period and ends with a cool-down period.

3 If a workout program is selected, set a maximum speed setting.

If the manual mode is selected, go to step 4.

If a workout program is selected, a number will be flashing in the SPEED display. This number is the *maximum speed* that the walking belt will reach during the selected program. If desired, press the SPEED Δ button repeatedly to change the maximum speed setting. If the maximum speed setting is increased, the difficulty level of the entire program will increase. If the maximum speed setting is decreased, the difficulty level of the entire program will decrease.

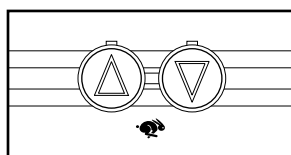

4 Press the START/STOP button.

A moment after the START/STOP button is pressed, the walking belt will begin to move. Hold the handrails and carefully begin walking.

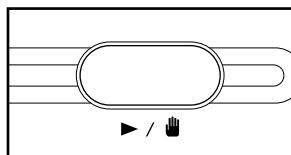

If the manual mode is selected: As you exercise, change the speed of the walking belt as desired by pressing the SPEED buttons.

To stop the walking belt, press the START/STOP button. The TIME/PACE display will begin to flash. To restart the walking belt, press the START/STOP button again. To stop the walking belt and reset the displays, press the START/STOP button, remove the key from the console, and then reinsert the key.

If a workout program is selected: The speed of the walking belt will change automatically during the program as shown by the graphs on the left side of the console. The time remaining in the program will be shown in the TIME display. During the last few seconds of each one-minute period of the program, four tones will sound to alert you that the speed may change. When the program is completed, the walking belt will slow to a stop.

Note: If the program is too difficult or too easy, the difficulty level of the program can be adjusted. Press the SPEED Δ or ∇ button. A number will begin to flash in the SPEED display. This number is the *maximum speed* that the walking belt will reach during the program. Press the SPEED Δ or ∇ button repeatedly to change the maximum speed setting. If the maximum speed setting is increased, the difficulty level of the entire program will increase. If the maximum speed setting is decreased, the difficulty level of the entire program will decrease.

To stop the program for a moment, press the START/STOP button. The TIME/PACE display will begin to flash. To restart the program, press the START/STOP button again. To stop the program and reset the displays, press the START/STOP button, remove the key from the console, and then reinsert the key.

5 Change the incline of the treadmill, if desired.

To change the incline, press the INCLINE buttons. Each time one of the buttons is pressed, the incline will change by 0.5%. Every three times a button is pressed, one additional indicator will light or darken in the incline display. The buttons can be held down to change the incline quickly. Note: After the buttons are pressed, it may take a moment for the treadmill to reach the selected incline setting.

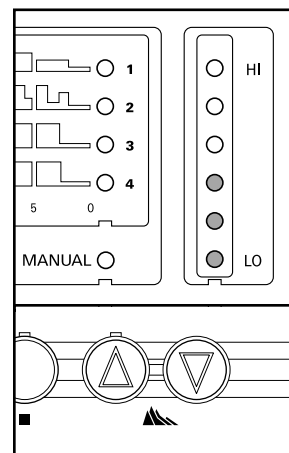

6 Follow your progress with the LED track and the four displays.

The LED Track—The LED track represents a distance of 1/4 mile. As you exercise, the indicators around the track will light one at a time until you have completed 1/4 mile. The indicators will then darken and another lap will begin.

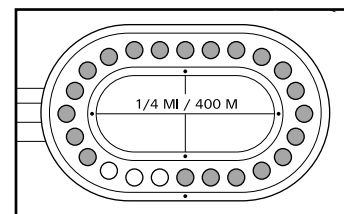

- **DISTANCE/LAPS display**—This display shows the total distance that you have walked and the number of laps you have completed (one lap equals 1/4 mile). The display will alternate between one number and the other every seven seconds. The LAPS indicator will light when the number of laps is shown.



- **TIME/PACE display**—This display shows the elapsed time and your current pace (pace is measured in *minutes per mile*). The display will alternate between one number and the other every seven seconds. The PACE indicator will light when your pace is shown. Note: When a workout program is selected, the display will show the time remaining in the program.



- **SPEED display**—This display shows the speed of the walking belt, in miles per hour or kilometers per hour. The KPH indicator will light when the speed is shown in kilometers per hour.



To change the unit of measurement, hold down the START/STOP button while inserting the key into the console. An “E” for “English” (miles per hour) or an “M” for “Metric” (kilometers per hour) will appear in the CALS/FAT CALS/PULSE display. Press the SPEED Δ button to change the unit of measurement. Remove and then reinsert the key.

- **CALS/FAT CALS/PULSE display**—This display shows the approximate numbers of *calories* and *fat calories* you have burned (see FAT BURNING on page 14). Every seven seconds, the display will change from one number to the other. The FAT indicator will light when the number of fat calories is shown. Note: This display will also show your heart rate when the pulse sensor is used (see step 7).

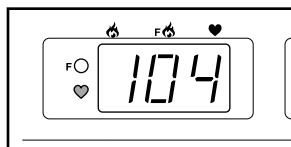

7 Measure your heart rate, if desired.

Stand on the foot rails and place your thumb on the pulse sensor as shown. The pulse sensor is pressure-activated—fully press it down. **(Do not press too hard, or the circulation in your thumb**

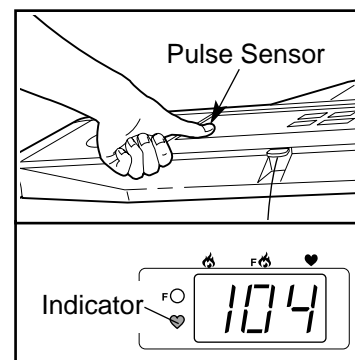

will be restricted, and your pulse will not be detected.) Next, raise your thumb slightly until the heart-shaped indicator by the CALS/FAT CALS/PULSE display flashes **steadily** and a “P” appears in the display. Hold your thumb at this level. After a few seconds, three dashes will appear in the display and then your heart rate will be shown. Hold your thumb on the sensor for another 15 seconds for the most accurate reading.

If the displayed heart rate appears to be too high or too low, or if your heart rate is not displayed, lift your thumb and allow the display to reset. Press down again on the sensor as described above. Make sure that your thumb is positioned as shown, and that you are applying the proper amount of pressure. Try the sensor several times until you become familiar with it. Remember to stand still while measuring your pulse.

8 When you are finished, remove the key.

Step onto the foot rails and remove the key from the console. Store the key in a secure place. In addition, move the on/off switch to the off position. (See the drawing near the bottom of page 8.)

THE INFORMATION MODE

To access the console’s information mode, hold down the START/STOP button while inserting the key into the console. An “E” for “English” (miles per hour) or an “M” for “Metric” (kilometers per hour) will appear in the CALS/FAT CALS/PULSE display. Pressing the SPEED Δ button will change the unit of measurement. The TIME/PACE display will show the total number of hours the treadmill has been used. The SPEED display will show the total number of miles accumulated on the treadmill. To exit the information mode, remove the key from the console.

HOW TO FOLD AND MOVE THE TREADMILL

HOW TO FOLD THE TREADMILL FOR STORAGE

Before folding the treadmill, adjust the incline to the lowest position. If this is not done, the treadmill may be permanently damaged. Remove the key and unplug the power cord. **CAUTION: You must be able to safely lift 20 kg (45 lbs.) in order to raise, lower, or move the treadmill.**

1. Hold the treadmill with your hands in the locations shown at the right. **CAUTION: To decrease the possibility of injury, bend your legs and keep your back straight. As you raise the treadmill, make sure to lift with your legs rather than your back.** Raise the treadmill about halfway to the vertical position.

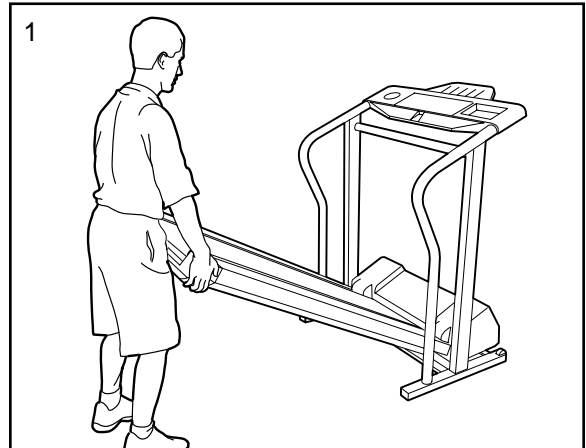

2. Move your right hand to the position shown and hold the treadmill firmly. Using your left thumb, slide the storage latch to the left and hold it. Raise the treadmill until the storage latch closes over the catch. **Make sure that the storage latch is fully closed over the catch.**

To protect the floor or carpet from damage, place a mat under the treadmill. Keep the treadmill out of direct sunlight. Do not leave the treadmill in the storage position in temperatures above 30°C (85°F).

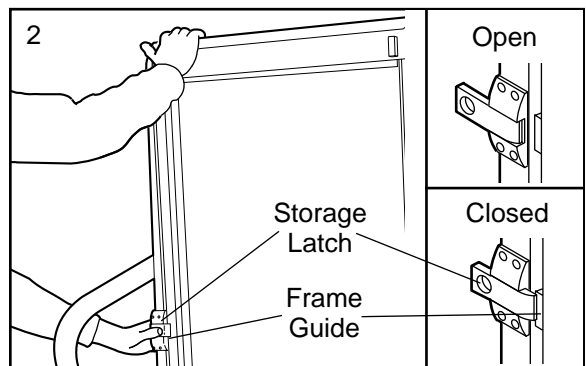

HOW TO MOVE THE TREADMILL

Before moving the treadmill, convert the treadmill to the storage position as described above. **Make sure that the storage latch is closed fully over the catch.**

1. Hold the handrails as shown and place one foot against a wheel.
2. Tilt the treadmill back until it rolls freely on the front wheels. Carefully move the treadmill to the desired location. **Never move the treadmill without tipping it back. To reduce the risk of injury, use extreme caution while moving the treadmill. Do not attempt to move the treadmill over an uneven surface.**
3. Place one foot on the base, and carefully lower the treadmill until it is resting in the storage position.

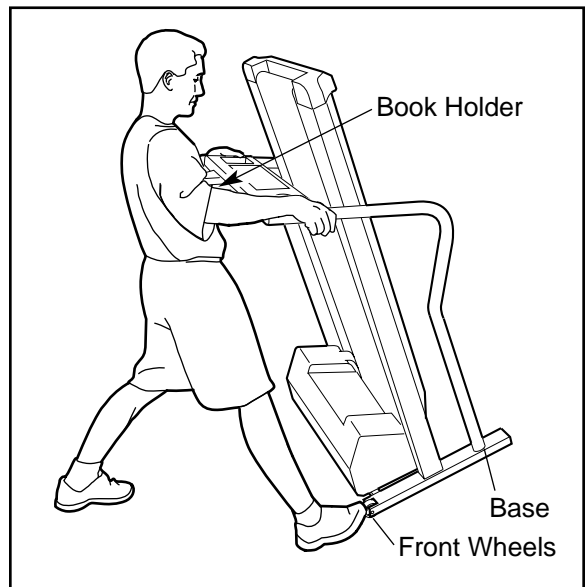

HOW TO LOWER THE TREADMILL FOR USE

1. Refer to drawing 2 above. Hold the upper end of the treadmill with your right hand as shown. Using your left thumb, slide the storage latch to the left and hold it. Pivot the treadmill down until the frame is past the storage latch.
2. Refer to drawing 1 above. Hold the treadmill firmly with both hands, and lower the treadmill to the floor. **CAUTION: To decrease the possibility of injury, bend your legs and keep your back straight.**

MAINTENANCE AND TROUBLE-SHOOTING

Most treadmill problems can be solved by following the steps below. Find the symptom that applies, and follow the steps listed. If further assistance is needed, please call our Customer Service Department toll-free at 1-888-936-4266, Monday through Friday, 8h00 until 18h00 Eastern Time (excluding holidays).

PROBLEM: The power does not turn on

SOLUTION: a. Make sure that the power cord is plugged into a surge suppressor, and that the surge suppressor is plugged into a properly grounded outlet. (See HOW TO PLUG IN THE POWER CORD on page 8.) Use only a CUL-listed surge suppressor, rated at 15 amps, with a 1mm² (14-gauge) cord of 1,5 m (5 ft.) or less in length.

b. After the power cord has been plugged in, make sure that the key is fully inserted into the console. (See step 1 on page 8.)

c. Check the circuit breaker located on the treadmill near the power cord. If the switch protrudes as shown, the circuit breaker has tripped. To reset the circuit breaker, wait for five minutes and then press the switch back in.

d. Check the on/off switch located at the front of the treadmill near the power cord. The switch must be in the on position.

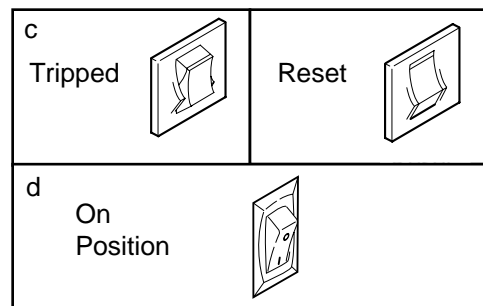

PROBLEM: The power turns off during use

SOLUTION: a. Check the circuit breaker located on the treadmill frame near the power cord (see c. above). If the circuit breaker has tripped, wait for five minutes and then press the switch back in.

b. Make sure that the power cord is plugged in.

c. Unplug the power cord, wait for five minutes, and then plug the power cord back in.

d. Remove the key from the console. Reinsert the key fully into the console.

e. Make sure that the on/off switch is in the on position.

f. If the treadmill still will not run, please call our Customer Service Department.

PROBLEM: The displays of the console do not function properly

SOLUTION: a. Remove the key from the console and **UNPLUG THE POWER CORD**. Next, remove the screws from the hood and carefully remove the hood. Locate the Reed Switch (97) and the Magnet (9) on the left side of the Pulley (10). Turn the Pulley until the Magnet is aligned with the Reed Switch. **Check the gap between the Magnet and the Reed Switch—it should be about 3 mm (1/8 in.).** If necessary, loosen the Screw (98) and move the Reed Switch slightly. Retighten the Screw. Reattach the hood and run the treadmill for a few minutes to check for a correct speed reading.

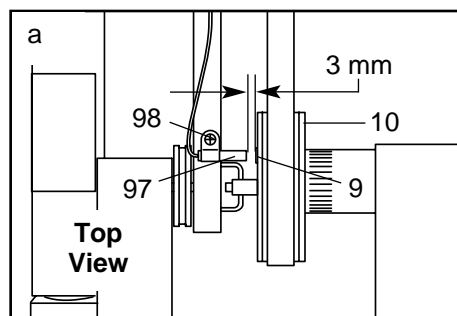

PROBLEM: The walking belt slows when walked on

SOLUTION: a. Use only a CUL-listed surge suppressor, rated at 15 amps, with a 1mm² (14-gauge) cord of 1,5 m (5 ft.) or less in length.

b. If the walking belt is overtightened, treadmill performance may decrease and the walking belt may become damaged. Remove the key and **UNPLUG THE POWER CORD**. Using the allen wrench, turn both rear roller adjustment bolts counterclockwise, 1/4 of a turn. When the walking belt is properly tightened, you should be able to lift each side of the walking belt 7 to 10 cm (3 to 4 in.) off the walking platform. Be careful to keep the walking belt centred. Plug in the power cord, insert the key and run the treadmill for a few minutes. Repeat until the walking belt is properly tightened.

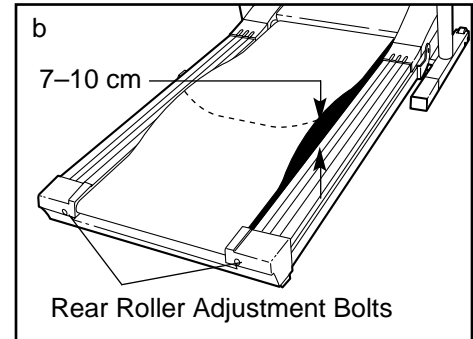

c. If the walking belt still slows when walked on, please call our Customer Service Department.

PROBLEM: The walking belt is off-centre or slips when walked on

SOLUTION: a. **If the walking belt has shifted to the left**, first remove the key and **UNPLUG THE POWER CORD**. Using the allen wrench, turn the left rear roller bolt clockwise 1/2 of a turn. Be careful not to overtighten the walking belt. **If the walking belt has shifted to the right**, turn the left rear roller bolt counterclockwise 1/2 of a turn. Plug in the power cord, insert the key and run the treadmill for a few minutes. Repeat until the walking belt is centered.

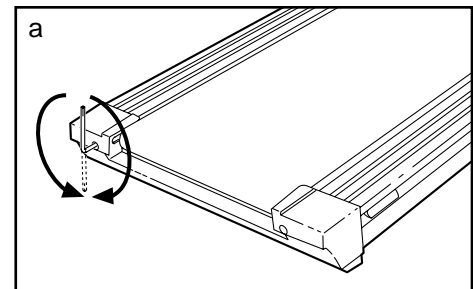

b. If the walking belt slips when walked on, first remove the key and **UNPLUG THE POWER CORD**. Using the allen wrench, turn both rear roller adjustment bolts clockwise, 1/4 of a turn. When the walking belt is correctly tightened, you should be able to lift each side of the walking belt 7–10 cm (3–4 in.) off the walking platform. Be careful to keep the walking belt centred. Plug in the power cord, insert the key and carefully walk on the treadmill for a few minutes. Repeat until the walking belt is properly tightened.

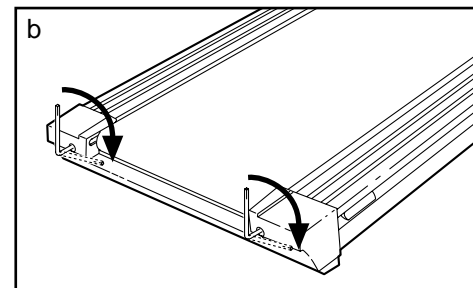

PROBLEM: The incline of the treadmill does not change correctly or does not change when iFIT.com CD's and videos are played

SOLUTION: a. With the key in the console, press one of the INCLINE buttons. **While the incline is changing, remove the key.** After a few seconds, re-insert the key. The treadmill will automatically rise to the maximum incline level and then return to the minimum level. This will recalibrate the incline system.

CONDITIONING GUIDELINES

⚠️ WARNING: Before beginning this or any exercise program, consult your physician. This is especially important for individuals over the age of 35 or individuals with pre-existing health problems.

The pulse sensor is not a medical device. Various factors, including your movement, may affect the accuracy of heart rate readings. The sensor is intended only as an exercise aid in determining heart rate trends in general.

The following guidelines will help you to plan your exercise program. For more detailed exercise information, obtain a reputable book or consult your physician.

EXERCISE INTENSITY

Whether your goal is to burn fat or to strengthen your cardiovascular system, the key to achieving the desired results is to exercise with the proper intensity. The proper intensity level can be found by using your heart rate as a guide. The chart below shows recommended heart rates for fat burning and aerobic exercise.

HEART RATE TRAINING ZONES (BPM)								
PERFORMANCE	165	155	145	140	130	125	115	
AEROBIC	145	138	130	125	118	110	103	
FAT BURN	125	120	115	110	105	95	90	
AGE	20	30	40	50	60	70	80	

To find the proper heart rate for you, first find your age near the bottom of the chart (ages are rounded off to the nearest ten years). Next, find the three numbers above your age. The three numbers define your “training zone.” The lowest number is the recommended heart rate for fat burning; the middle number is the recommended heart rate for aerobic exercise; and the highest number is for advanced conditioning.

Fat Burning

To burn fat effectively, you must exercise at a relatively low intensity level for a sustained period of time. During the first few minutes of exercise, your body uses easily accessible *carbohydrate calories* for energy. Only after the first few minutes does your body begin to use stored *fat calories* for energy. If your goal is to burn fat,

adjust the speed and incline of the treadmill until your heart rate is near the lowest number in your training zone.

Aerobic Exercise

If your goal is to strengthen your cardiovascular system, your exercise must be “aerobic.” Aerobic exercise is activity that requires large amounts of oxygen for prolonged periods of time. This increases the demand on the heart to pump blood to the muscles, and on the lungs to oxygenate the blood. For aerobic exercise, adjust the speed and incline of the treadmill until your heart rate is near the middle of your training zone.

High Performance Athletic Conditioning

If your goal is high performance athletic conditioning, adjust the speed and incline of the treadmill until your heart rate is near the highest number in your training zone. Note: During the first few weeks of your exercise program, keep your heart rate near the low end of your training zone.

WORKOUT GUIDELINES

Each workout should include the following three parts:

A Warm-up—Start each workout with 5 to 10 minutes of stretching and light exercise. A proper warm-up increases your body temperature, heart rate, and circulation in preparation for exercise.

Training Zone Exercise—After warming up, increase the intensity of your exercise until your pulse is in your training zone for 20 to 60 minutes. (During the first few weeks of your exercise program, do not keep your pulse in your training zone for longer than 20 minutes.) Breathe regularly and deeply as you exercise—never hold your breath.

A Cool-down—Finish each workout with 5 to 10 minutes of stretching to cool down. This will increase the flexibility of your muscles and will help prevent post-exercise problems.

EXERCISE FREQUENCY

To maintain or improve your condition, complete three workouts each week, with at least one day of rest between workouts. After a few months, you may complete up to five workouts each week if desired. The key to success is to make exercise a regular and enjoyable part of your everyday life

ORDERING REPLACEMENT PARTS

To order replacement parts, call our Customer Service Department toll-free at 1-888-936-4266, Monday through Friday 8h00 until 18h30 Eastern Time (excluding holidays). When ordering parts, please be prepared to give the following information:

- the MODEL NUMBER OF THE PRODUCT (PCTL62590)
- the NAME OF THE PRODUCT (PROFORM® 625EX treadmill)
- the SERIAL NUMBER OF THE PRODUCT (see the front cover of this manual)
- the KEY NUMBER AND DESCRIPTION OF THE PART(S) (see the EXPLODED DRAWING and PART LIST attached in the center of this manual).

ATTACH
STAMP
HERE

ICON of Canada, Inc.
900 de l'Industrie
St-Jérôme, Québec
Canada, J7Y 4B8

LIMITED WARRANTY

ICON OF CANADA INC., (ICON), warrants this product to be free from defects in workmanship and material, under normal use and service conditions, for a period of one (1) year from the date of purchase. This warranty extends only to the original purchaser. ICON's obligation under this warranty is limited to replacing or repairing, at ICON's option, the product at one of its authorized service centers. All products for which warranty claim is made must be received by ICON at one of its authorized service centers with all freight and other transportation charges prepaid, accompanied by sufficient proof of purchase. All returns must be pre-authorized by ICON. This warranty does not extend to any product or damage to a product caused by or attributable to freight damage, abuse, misuse, improper or abnormal usage or repairs not provided by an ICON authorized service center, to products used for commercial or rental purposes, or to products used as store display models. No other warranty beyond that specifically set forth above is authorized by ICON.

ICON is not responsible or liable for indirect, special or consequential damages arising out of or in connection with the use or performance of the product or damages with respect to any economic loss, loss of property, loss of revenues or profits, loss of enjoyment or use, costs of removal, installation or other consequential damages of whatsoever nature. Some provinces do not allow the exclusion or limitation of incidental or consequential damages. Accordingly, the above limitation may not apply to you. The warranty extended hereunder is in lieu of any and all other warranties and any implied warranties of merchantability or fitness for a particular purpose is limited in its scope and duration to the terms set forth herein. Some provinces do not allow limitations on how long an implied warranty lasts. Accordingly, the above limitation may not apply to you.

This warranty gives you specific legal rights. You may also have other rights which vary from province to province or so specified by the retailer of your equipment.

ICON OF CANADA, 900 de l'Industrie, St. Jérôme, QC J7Y 4B8

✂



PRODUCT WARRANTY REGISTRATION

IMPORTANT: MAIL WITHIN 14 DAYS OF PURCHASE

NAME: _____ PHONE: _____

ADDRESS: _____

COUNTY: _____ POSTCODE: _____

MODEL NO. _____ SERIAL NO. _____ PURCHASE DATE: _____

RETAILER NAME: _____ RETAILER ADDRESS: _____

<p>1) Primary user(s) of product: <input type="checkbox"/> Male <input type="checkbox"/> Female <input type="checkbox"/> Family</p> <p>2) Age of primary user: <input type="checkbox"/> 0-24 <input type="checkbox"/> 35-44 <input type="checkbox"/> 55-64 <input type="checkbox"/> 25-34 <input type="checkbox"/> 45-54 <input type="checkbox"/> 65 and over</p> <p>3) Annual household income: <input type="checkbox"/> 0-9,999 <input type="checkbox"/> 15,000-19,999 <input type="checkbox"/> 10,000-14,999 <input type="checkbox"/> 20,000+</p> <p>4) How many times a week do you exercise? <input type="checkbox"/> Less than 3 times <input type="checkbox"/> 3 times or more</p> <p>5) Have you ever purchased an ICON product before? <input type="checkbox"/> Yes <input type="checkbox"/> No</p> <p>6) Where did you first see or hear about ICON products? <input type="checkbox"/> Magazine <input type="checkbox"/> Friend/relative <input type="checkbox"/> Newspaper Ad <input type="checkbox"/> Store <input type="checkbox"/> Other</p> <p>7) What was the primary reason for purchasing this ICON product? <input type="checkbox"/> Store Employee <input type="checkbox"/> Television Ads <input type="checkbox"/> Colour <input type="checkbox"/> Electronic Features <input type="checkbox"/> Magazine Ads <input type="checkbox"/> Price <input type="checkbox"/> Product Design <input type="checkbox"/> Product Innovation <input type="checkbox"/> Other Features</p>	<p>8) Did you consider purchasing fitness equipment from another manufacturer? <input type="checkbox"/> No <input type="checkbox"/> Yes What other Manufacturer? _____</p> <p>9) Based on your impression of what you have purchased, would you buy another ICON product? <input type="checkbox"/> Yes <input type="checkbox"/> No <input type="checkbox"/> No Opinion If not, what other brand name equipment would you purchase? _____</p> <p>10) What other type of exercise equipment do you own? <input type="checkbox"/> Bicycle <input type="checkbox"/> Exercise Cycle <input type="checkbox"/> Treadmill <input type="checkbox"/> Home Gym <input type="checkbox"/> Weight Bench <input type="checkbox"/> Stepper <input type="checkbox"/> Cardio Glide <input type="checkbox"/> Other</p> <p>11) Which type of magazines do you read regularly? <input type="checkbox"/> Sports <input type="checkbox"/> Fitness <input type="checkbox"/> Motoring <input type="checkbox"/> Business <input type="checkbox"/> Computer <input type="checkbox"/> General</p> <p>12) Do you wish to be sent further bulletins about ICON products? <input type="checkbox"/> Yes <input type="checkbox"/> No</p>
---------------------------------------------------------------------------------------------------------------------------------------------------------------------------------------------------------------------------------------------------------------------------------------------------------------------------------------------------------------------------------------------------------------------------------------------------------------------------------------------------------------------------------------------------------------------------------------------------------------------------------------------------------------------------------------------------------------------------------------------------------------------------------------------------------------------------------------------------------------------------------------------------------------------------------------------------------------------------------------------------------------------------------------------------------------------------------------------------------------------------------------------------------------------------------------------------------------------------------------------------------------------------------------------------------------------------------------------------------------------------------------------------------------------------------------------------------------------------------------------------------------------------------------------------------------------------------------------------------------------------	----------------------------------------------------------------------------------------------------------------------------------------------------------------------------------------------------------------------------------------------------------------------------------------------------------------------------------------------------------------------------------------------------------------------------------------------------------------------------------------------------------------------------------------------------------------------------------------------------------------------------------------------------------------------------------------------------------------------------------------------------------------------------------------------------------------------------------------------------------------------------------------------------------------------------------------------------------------------------------------------------------------------------------------------------------------------------------------------------------------------------------------------------------------------------------------------------------------------------------------------------------------------------------------------------------------------

THANK YOU FOR YOUR TIME

© 2001 ICON of Canada, Inc. Printed in Canada

PROFORM® is a registered trademark of ICON Health & Fitness, Inc.

REMOVE THIS EXPLODED DRAWING AND PART LIST FROM THE MANUAL.

Save this page for future reference.

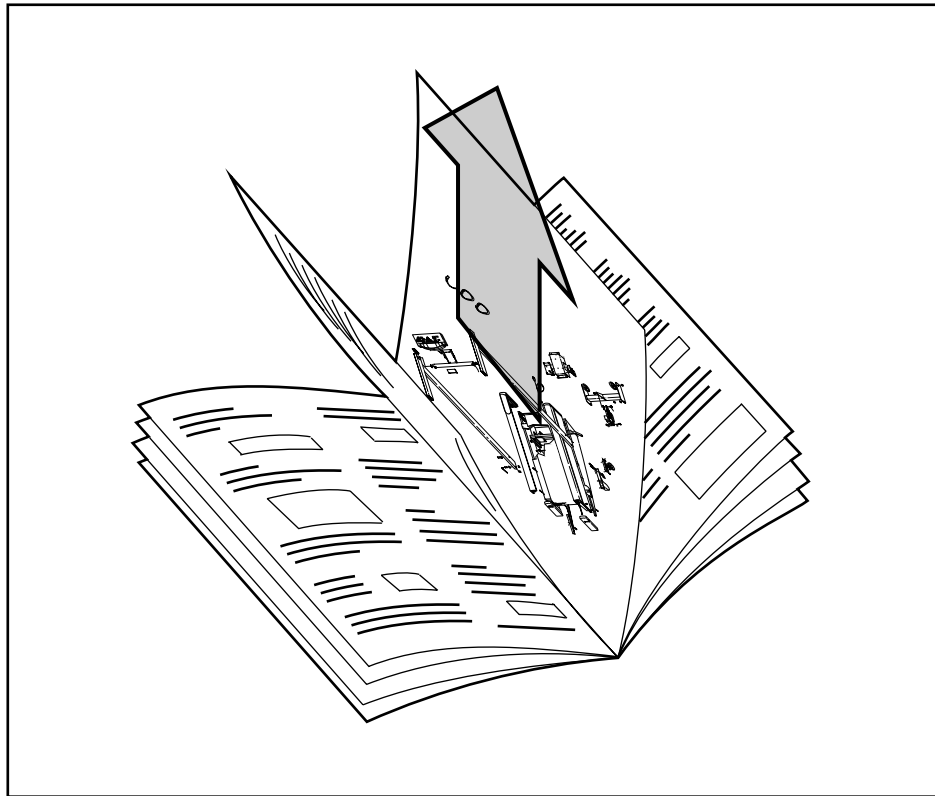

Note: Specifications are subject to change without notice. For information about ordering replacement parts, see the back cover of the User's Manual.

PART LIST—Model No. PCTL62590

R1101A

Key No.	Qty.	Description	Key No.	Qty.	Description	Key No.	Qty.	Description
1	1	Frame	48	1	Incline Bolt	92	1	Front Roller Adj. Bolt
2	4	Catch Screw/Frame Guide Screw	49	1	Shock	93	1	Incline Leg
3	2	Frame Guide	50	1	Incline Cover	94	1	Choke Plate
4	1	Rear Roller	51	1	Cotter Pin	95	1	Choke
5	2	Roller Guard	52	1	Clevis Pin	96	1	Clip
6	2	Platform Screw	53	2	Wheel Bolt	97	1	Reed Switch
7	2	Foot Rail	54	4	Hood Mount Screw	98	12	Belly Pan
8	1	Walking Platform	55	4	Base Pad			Fastener/Clip Screw
9	1	Magnet	56	4	Stand-Off	99	1	Front Belly Pan
10	1	Front Roller/Pulley	57	2	Extension Leg Screw	100	1	Ground Wire
11	1	Walking Belt	58	4	Isolator Nut	101	1	Adhesive Clip
12	2	Center Isolator	59	2	Extension Leg	102	1	Allen Wrench
13	4	Rear Isolator Bolt	60	1	Left Handrail	103	1	Endcap Plug
14	1	Latch Warning Decal	61	2	Extension Leg	104	6	Endcap Fastener
15	11	Belly Pan Screw			Endcap	105	1	Endcap Foot (Right)
16	1	Belly Pan	62	1	Right Handrail	106	4	Endcap Bolt
17	4	Isolator	63	1	Rear Endcap	107	2	Rear Roller Adj. Bolt
18	2	Frame Pivot Bolt	64*	1	Console Assembly	108	7	Adj. Washer/Pad
19	2	Left Frame Guide	65	2	Front Wheel			Washer
		Spacer	66	1	Motor/Pulley/Flywheel/Fan	109	2	Frame Spacer
20	1	Hood	67	1	Motor Pivot Bolt	110	1	Reading Rack
21	1	Key/Clip	68	1	Motor Tension Nut	111	2	Rear Platform Screw (long)
22	2	Upright Plug	69	1	Motor Star Washer	112	1	Motor/Controller
23	2	Console Cover	70	1	Motor Tension Washer			Wire
24	4	Handrail Screw			Washer	113	1	Small Nut
25	1	Wire Tie Holder	71	1	Motor Tension Bolt	114	2	Right Frame Guide
26	2	Releasable Wire Tie	72	1	Motor Belt			Spacer
27	1	Speed Potentiometer	73	1	Pulley/Flywheel/Fan	115	1	Motor Pivot Nut
28	1	Incline Disk	74	1	Motor	116	4	Belt Guide Screw
29	1	Small Bolt	75	5	8" Wire Tie	117	1	2 x 4 1/2" Spacer
30	2	Handrail Bolt	76	2	Belt Guide	118	2	Front Isolator Nut
31	2	Handrail Washer	77	1	Endcap Foot (left)	#	1	4" Black Wire, 2F
32	1	Upright	78	12	3/4" Screw	#	1	20" White Wire, Pig Tail
33	14	Latch Screw	79	2	Small Star Washer			
34	1	Latch	80	5	Hood Anchor	#	1	8" White Wire, Male/Female
35	1	Wire Harness	81	1	Circuit Breaker			
36	2	Grommet	82	1	Power Cord	#	1	8" White Wire, 2 Female
37	5	Incline Motor Nut	83	1	Power Cord			
38	2	Cage Nut			Grommet	#	1	8" Blue Wire, Pig Tail
39	2	Incline Leg Pivot Bolt	84	1	On/off Switch	#	1	8" Green Wire, Female/Ring
40	1	Disk Sensor	85	1	Outlet Bracket			
41	2	Incline Leg Pivot Nut	86	5	Hood Bracket	#	1	User's Manual
42	1	Incline Cover Shield	87	2	Spacer			
43	4	Base Pad Screw	88	1	Power Supply			
44	1	Incline Motor Spacer	89	1	Electronics Bracket			
45	1	Incline Motor	90	1	Console Wire			
46	1	Console Base			Harness			
47	1	Incline Stop Bracket	91	1	Controller			

* Includes all parts shown in the box

These parts are not illustrated

EXPLODED DRAWING—Model No. PCTL62590

R1101A

