

PRO-FORM XP™

THINLINE 480

Model No. 831.23844.0

Serial No. _____

Write the serial number in the space above for reference.

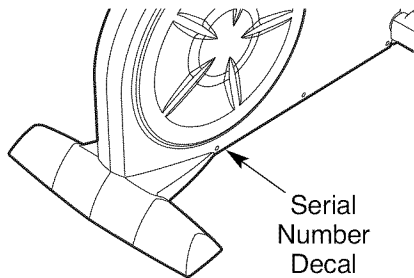

- Assembly
- Operation
- Maintenance
- Part List and Drawing

CAUTION

Read all precautions and instructions in this manual before using this equipment. Keep this manual for future reference.

ELLIPTICAL EXERCISER

User's Manual

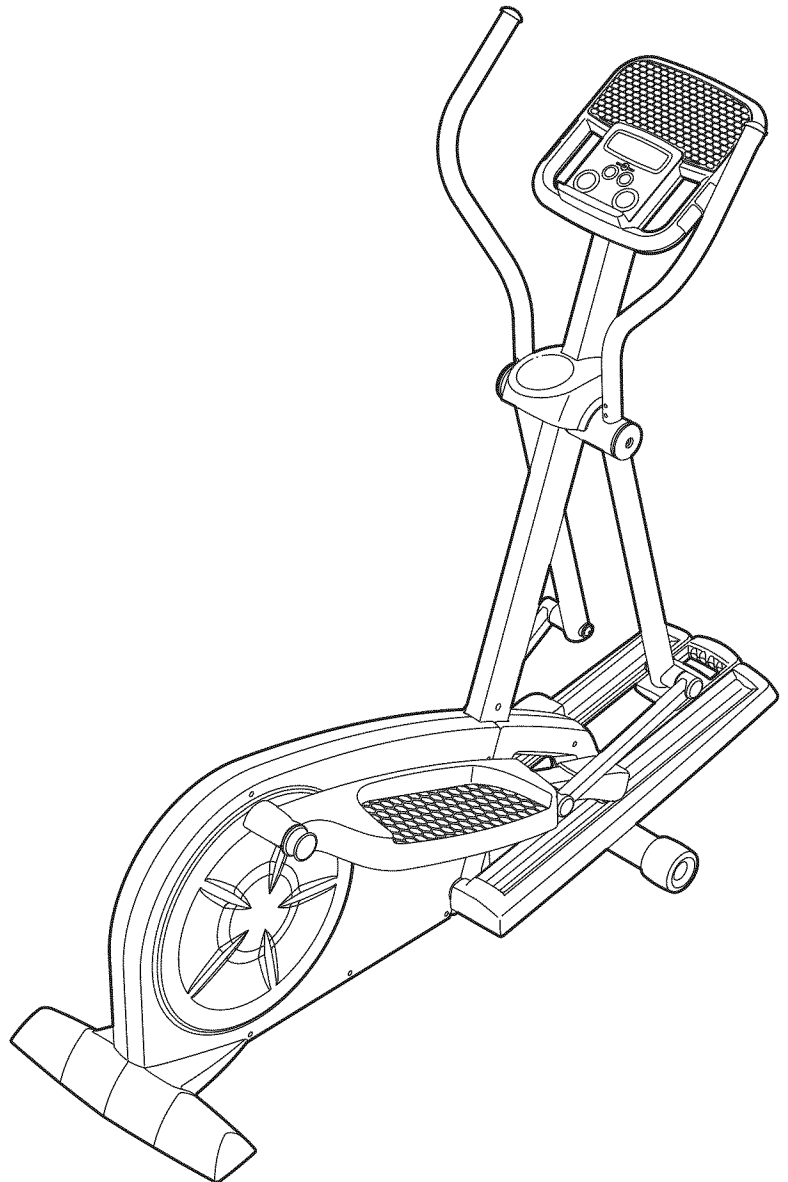

Sears, Roebuck and Co., Hoffman Estates, IL 60179

TABLE OF CONTENTS

WARNING DECAL PLACEMENT2
IMPORTANT PRECAUTIONS3
BEFORE YOU BEGIN4
ASSEMBLY5
HOW TO USE THE ELLIPTICAL EXERCISER12
MAINTENANCE AND TROUBLESHOOTING21
EXERCISE GUIDELINES22
PART LIST24
EXPLODED DRAWING26
ORDERING REPLACEMENT PARTSBack Cover
90 DAY FULL WARRANTYBack Cover

WARNING DECAL PLACEMENT

This drawing shows the location(s) of the warning decal(s). **If a decal is missing or illegible, call 1-888-533-1333 and request a free replacement decal. Apply the decal in the location shown.** Note: The decal(s) may not be shown at actual size.

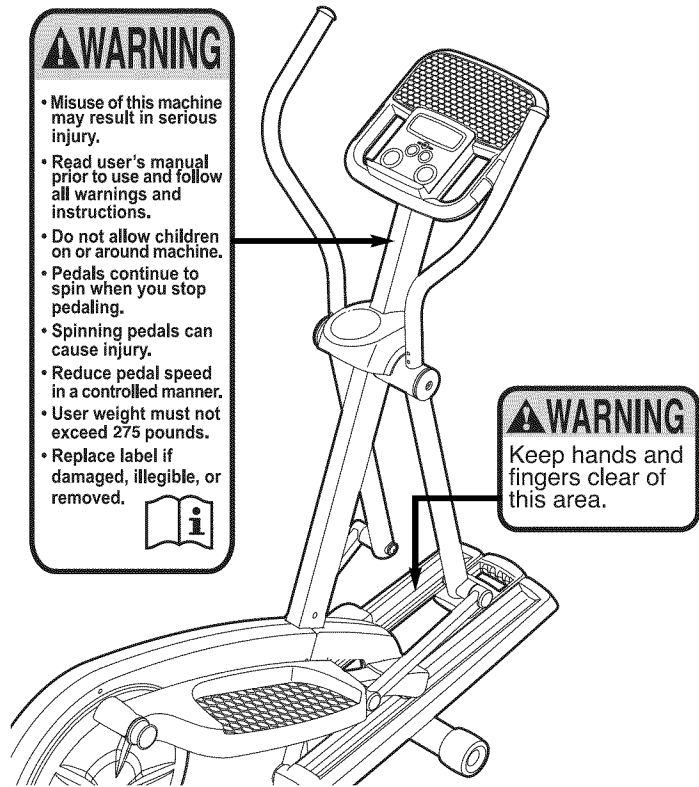

IMPORTANT PRECAUTIONS

⚠ WARNING: To reduce the risk of serious injury, read all important precautions and instructions in this manual and all warnings on your elliptical exerciser before using your elliptical exerciser. Sears assumes no responsibility for personal injury or property damage sustained by or through the use of this product.

1. Before beginning any exercise program, consult your physician. This is especially important for persons over the age of 35 or persons with pre-existing health problems.
2. It is the responsibility of the owner to ensure that all users of the elliptical exerciser are adequately informed of all precautions.
3. Your elliptical exerciser is intended for home use only. Do not use your elliptical exerciser in a commercial, rental, or institutional setting.
4. Keep your elliptical exerciser indoors, away from moisture and dust. Place your elliptical exerciser on a level surface, with a mat beneath it to protect the floor or carpet. Make sure that there is enough clearance around your elliptical exerciser to mount, dismount, and use it.
5. Inspect and properly tighten all parts regularly. Replace any worn parts immediately.
6. Keep children under age 12 and pets away from your elliptical exerciser at all times.
7. Your elliptical exerciser should not be used by persons weighing more than 275 lbs. (124 kg).
8. Wear appropriate exercise clothes when exercising; do not wear loose clothes that could become caught on your elliptical exerciser. Always wear athletic shoes for foot protection.
9. Hold the handgrip pulse sensor or the upper body arms when mounting, dismounting, or using your elliptical exerciser.
10. Keep your back straight while using your elliptical exerciser; do not arch your back.
11. The pulse sensor is not a medical device. Various factors, including the user's movement, may affect the accuracy of heart rate readings. The pulse sensor is intended only as an exercise aid in determining heart rate trends in general.
12. When you stop exercising, allow the pedals to slowly come to a stop.
13. If you feel pain or dizziness while exercising, stop immediately and cool down.
14. Use your elliptical exerciser only as described in this manual.

BEFORE YOU BEGIN

Thank you for purchasing the revolutionary PROFORM XP™ THINLINE 480 elliptical exerciser. The THINLINE 480 elliptical exerciser provides a wide array of features designed to make your workouts at home more effective and enjoyable.

For your benefit, read this manual carefully before you use the elliptical exerciser. If you have questions after reading this manual, please see the back

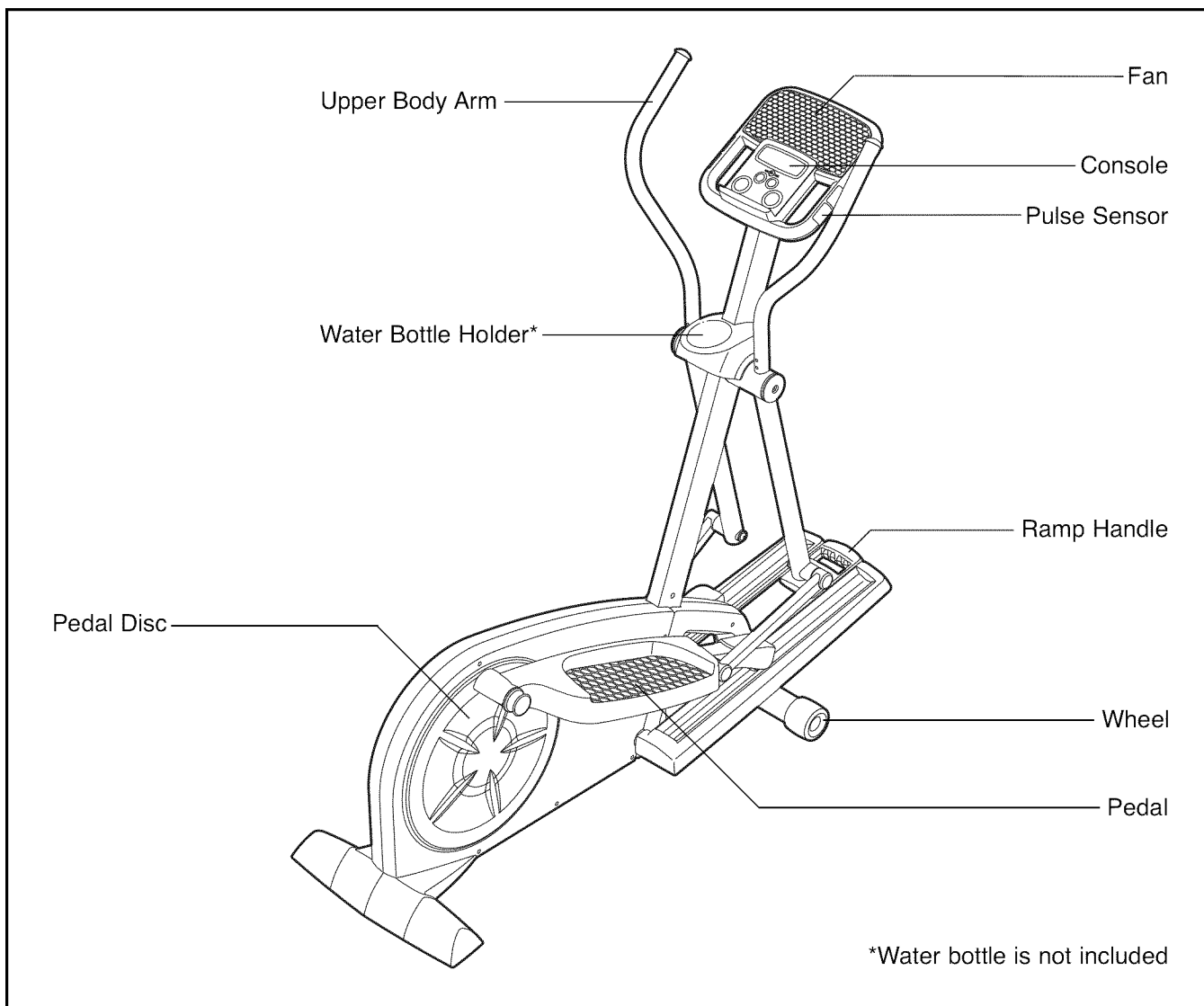

cover of this manual. To help us assist you, note the product model number and serial number before contacting us. The model number and the location of the serial number decal are shown on the front cover of this manual.

Before reading further, please familiarize yourself with the parts that are labeled in the drawing below.





ASSEMBLY

Assembly requires two persons. Place all parts of the elliptical exerciser in a cleared area and remove the packing materials. Do not dispose of the packing materials until assembly is completed.

Assembly requires the included tools and your own Phillips screwdriver  , adjustable wrench  , and rubber mallet  .

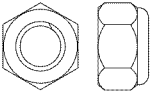
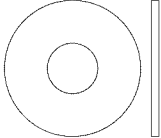
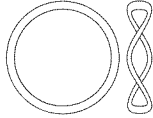
As you assemble the elliptical exerciser, use the drawings below to identify small parts. The number in parentheses below each drawing is the key number of the part, from the PART LIST near the end of this manual. The number following the parentheses is the quantity needed for assembly. **Note: Some small parts may have been preassembled. If a part is not in the parts bag, check to see if it has been preassembled. If a part is missing, call 1-888-533-1333.**

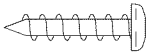
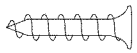
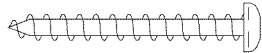
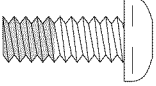
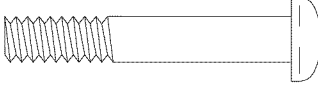
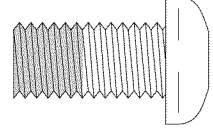
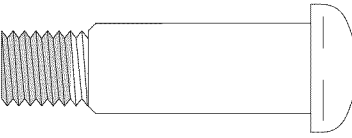
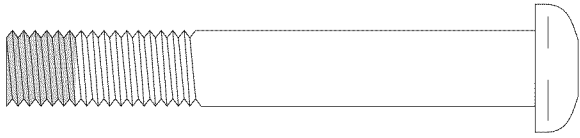
 M6 Nylon Locknut (77)-4	 M6 Large Washer (90)-4	 Wave Washer (88)-6	 M10 Split Washer (78)-10
 M4 x 16mm Screw (84)-14	 M4 x 16mm Flat Head Screw (94)-4	 M4 x 32mm Screw (95)-2	
 M6 x 16mm Patch Screw (80)-6	 M6 x 38mm Button Bolt (76)-4	 M10 x 20mm Patch Screw (79)-4	
 M10 x 41mm Shoulder Patch Screw (63)-2	 M10 x 70mm Patch Screw (75)-6		

1.

To make assembly easier, read the information on page 5 before you begin assembling the elliptical exerciser.

Pull the ramp handle outward and lower the Ramp (104) until it rests on the Frame (1).

Attach a Wheel (50) to the front of the Frame (1) with an M10 x 41mm Shoulder Patch Screw (63).

Attach the other Wheel (not shown) in the same way.

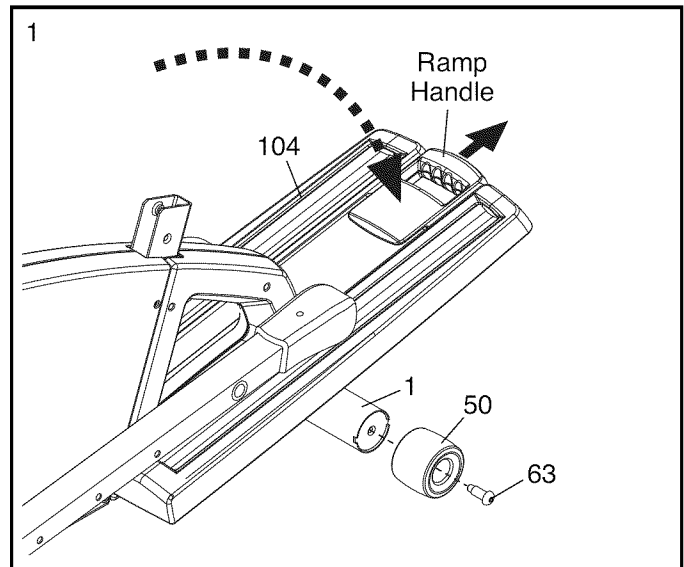

2. Identify the Right Frame Cover (49), which is marked with a "Right" sticker. Then, orient the Right Frame Cover with the rounded side in the indicated location. While another person lifts the rear of the Frame (1), attach the Right Frame Cover with two M4 x 16mm Screws (84).

Repeat this step for the Left Frame Cover (48).

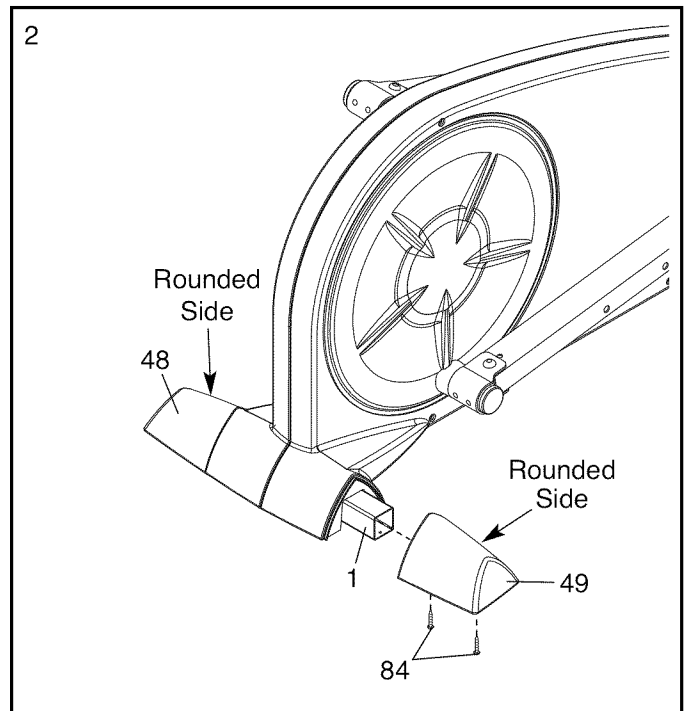

3. **Tip: Do not pinch the Wire Harness (100). Start all screws before tightening any of them.**

Have another person hold the Upright (2) near the Frame (1). Locate the wire tie in the Upright. Tie the lower end of the wire tie to the Wire Harness (100). Next, pull the upper end of the wire tie upward out of the top of the Upright. Then, untie and discard the wire tie. **Tip: To prevent the Wire Harness from falling inside the Upright, secure the Wire Harness with a rubber band.**

Attach the Upright (2) to the Frame (1) with four M10 x 20mm Patch Screws (79), and four M10 Split Washers (78). **Do not tighten the Patch Screws yet.**

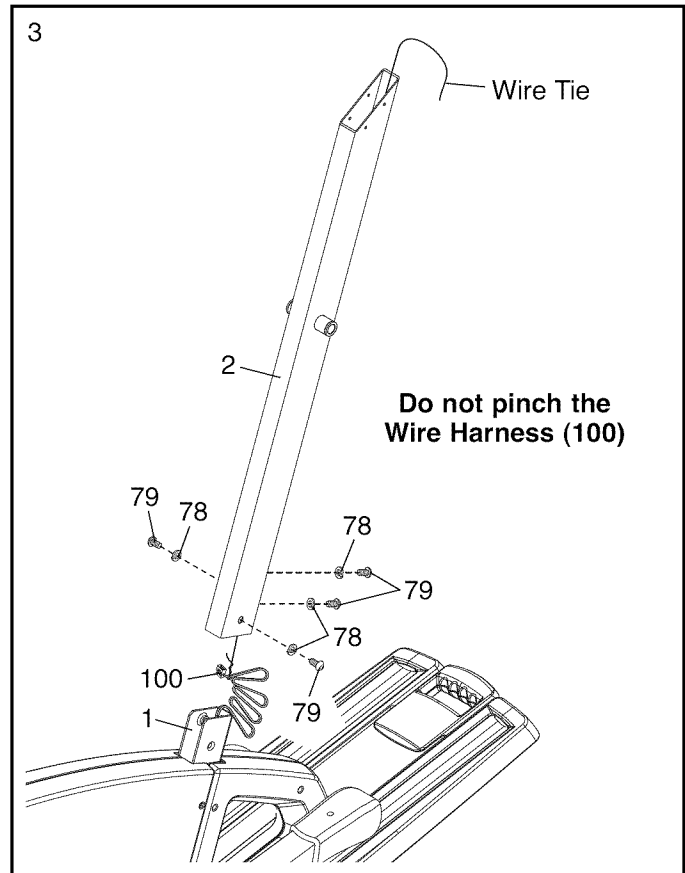

4. Orient the Water Bottle Holder (5) as shown and slide it onto the Upright (2). Attach the Water Bottle Holder with two M4 x 32mm Screws (95).

Tip: Do not pinch the Wire Harness (100). Slide the Console Cover (96) onto the Upright (2) and move it downward to the Water Bottle Holder. Then, insert the Console Bracket (3) into the top of the Upright. Attach the Console Bracket with four M4 x 16mm Screws (84).

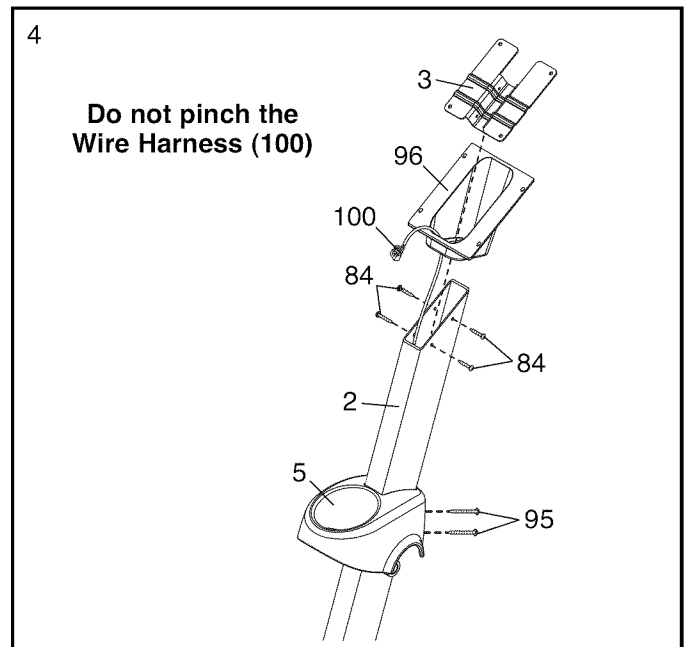

5. The Console (4) can use four 1.5V “D” batteries (not included); alkaline batteries are recommended. **IMPORTANT: If the Console has been exposed to cold temperatures, allow it to warm to room temperature before inserting batteries. Otherwise, you may damage the console displays or other electronic components.** Remove the screws, remove the battery cover, insert the batteries into the battery compartment, and then reattach the battery cover. **Make sure to orient the batteries as shown by the diagram inside the battery compartment.**

To purchase an optional AC adapter, contact the store where you purchased this product or call the telephone number on the cover of this manual. To avoid damaging the console, use only a manufacturer-supplied AC adapter. Plug one end of the AC adapter into the jack on the console; plug the other end into an outlet installed in accordance with all local codes and ordinances.

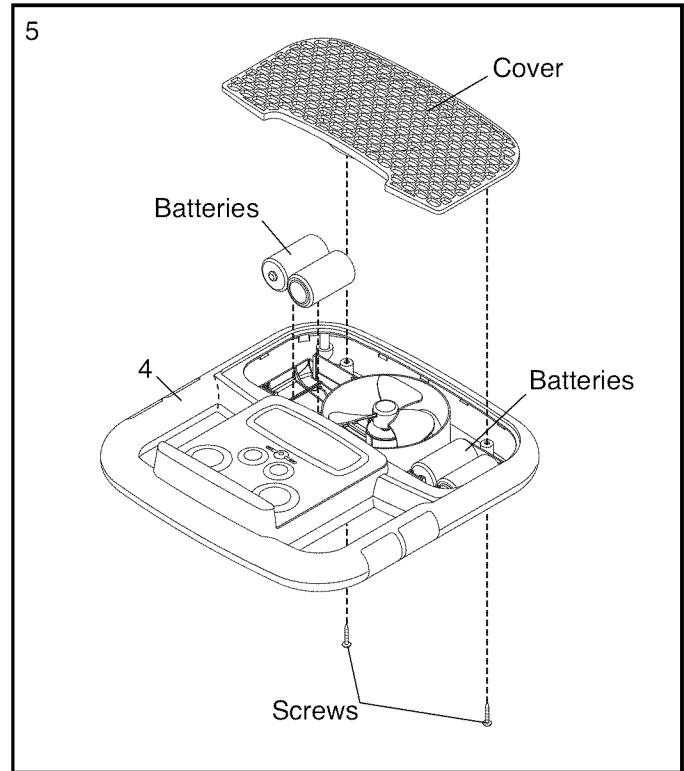

6. While a second person holds the Console (4) near the Upright (2), connect the console wire to the Wire Harness (100).

Tip: Do not pinch the wires. Attach the Console (4) with four M4 x 16mm Flat Head Screws (94).

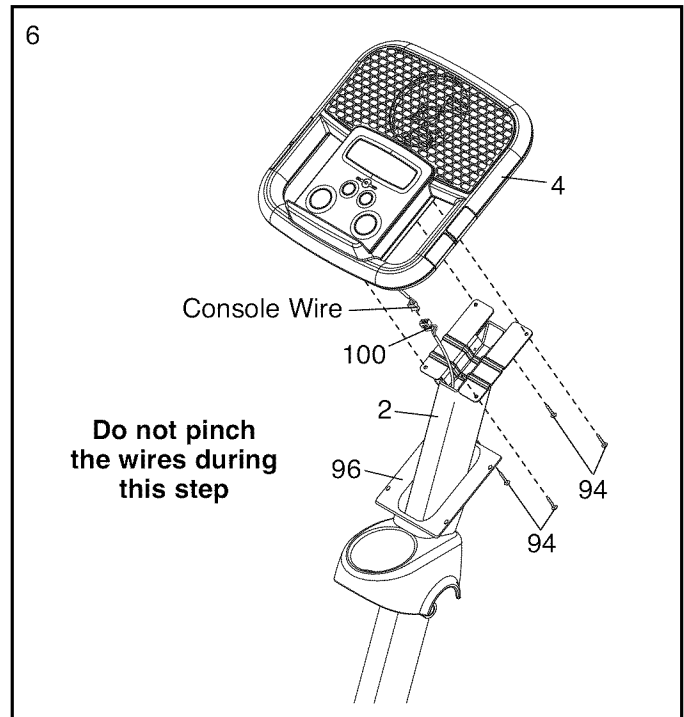

7. Slide the Console Cover (96) (**see the drawing in step 6**) upward to the Console (4). Attach the Console Cover with four M4 x 16mm Screws (84).

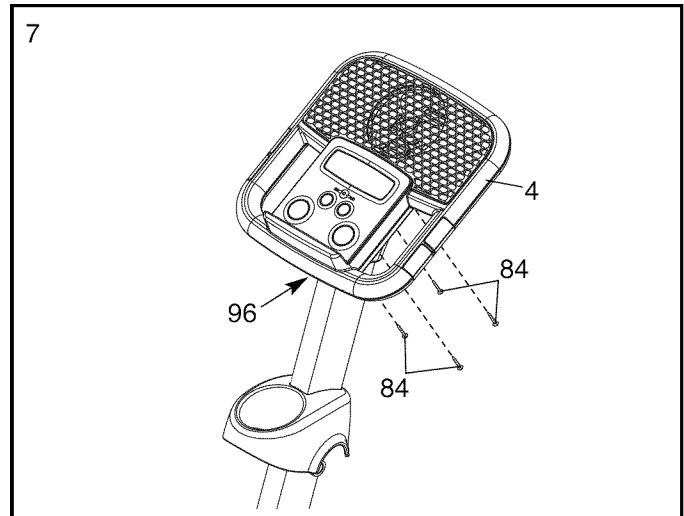

8. Apply a generous amount of the included grease to the Pivot Axle (16). Then, apply a small amount of grease to two Wave Washers (88).

Insert the Pivot Axle (16) into the Upright (2). Slide a Wave Washer (88) onto each end of the Pivot Axle.

Identify the Left Upper Body Leg (6), which is marked with a "Left" sticker. Slide the Left Upper Body Leg onto the Pivot Axle (16). Attach the Left Upper Body Leg with an M6 x 16mm Patch Screw (80) and a Large Axle Cover (20).

Attach the Right Upper Body Leg (31) in the same way.

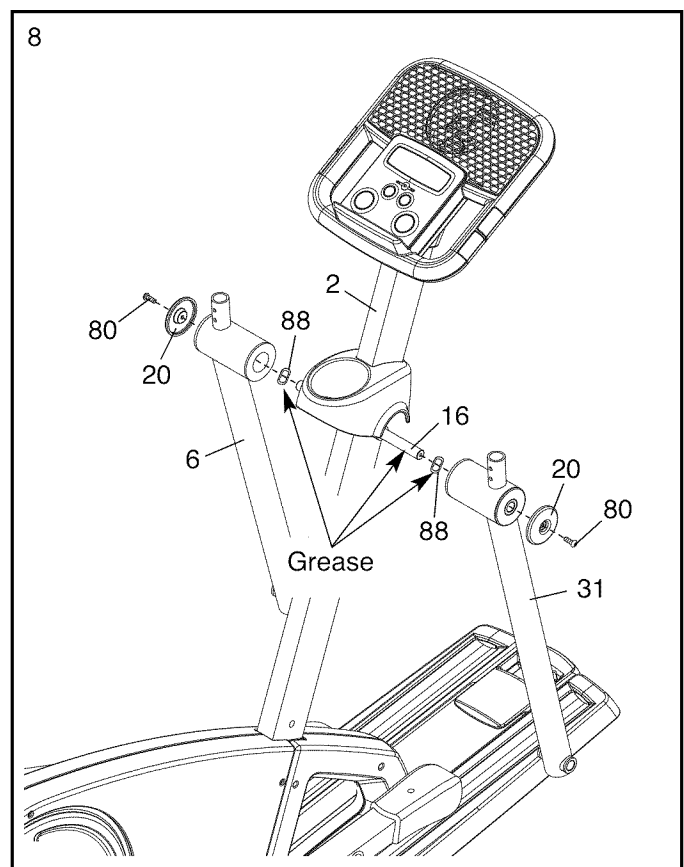

9. Attach the Left Pedal (12) to the left Pedal Arm (14) with three M10 x 70mm Patch Screws (75), three M10 Split Washers (78), and an M4 x 16mm Screw (84).

Repeat this step for the other side of the elliptical exerciser.

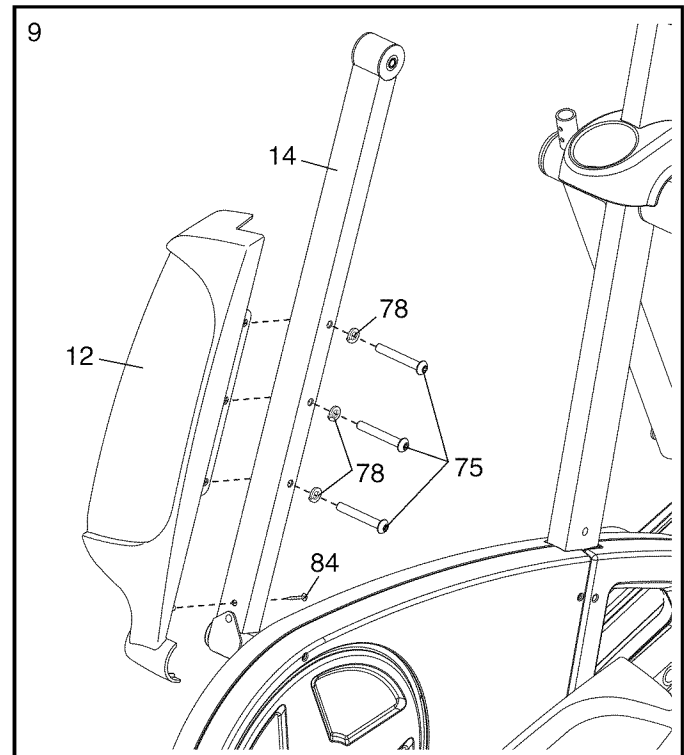

10. Apply a small amount of grease to two Wave Washers (88) and to the axles on a Pedal Arm Axle (21).

Identify an Upper Body Leg Spacer (113), which has a curved side. Slide a Wave Washer (88) and the Upper Body Leg Spacer onto the indicated axle of the Pedal Arm Axle (21); **make sure that the curved side of the Upper Body Leg Spacer is facing away from the Pedal Arm Axle.**

Identify a Pedal Leg Spacer (114), which has a flat side. Slide a Wave Washer (88) and the Pedal Leg Spacer onto the other axle of the Pedal Arm Axle (21); **make sure that the flat side of the Pedal Leg Spacer is facing away from the Pedal Arm Axle.**

Repeat this step for the other Pedal Arm Axle (not shown).

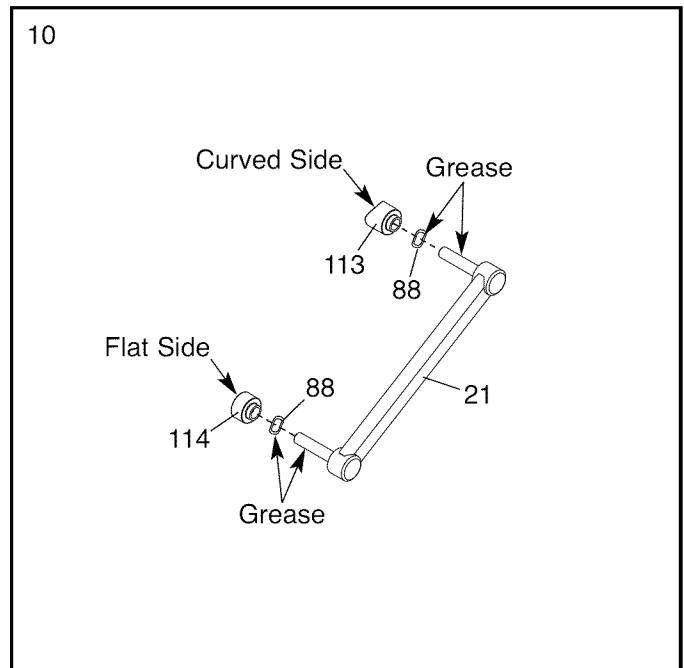

11. At the same time, insert a Pedal Arm Axle (21) into the Right Upper Body Leg (31) and into the right Pedal Arm (14); **make sure that the Upper Body Leg Spacer (113) and the Pedal Leg Spacer (114) are in the indicated locations.**

Attach the Right Upper Body Leg (31) with an M6 x 16mm Patch Screw (80) and an M6 Large Washer (90).

Then, attach the right Pedal Arm (14) with an M6 x 16mm Patch Screw (80) and an M6 Large Washer (90).

Repeat this step for the other side of the elliptical exerciser.

See step 3. Tighten the four M10 x 20mm Patch Screws (79). **Tip: Tighten the two Patch Screws on the front of the elliptical exerciser before tightening the other two Patch Screws.**

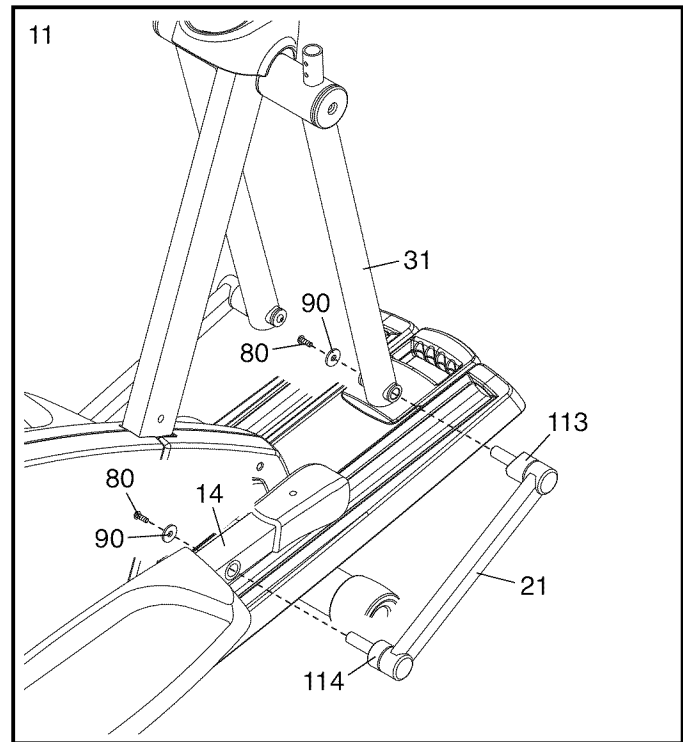

12. Identify the Right Upper Body Arm (9), which is marked with a "Right" sticker. Orient the Right Upper Body Arm as shown; **make sure that the hexagonal holes in the Right Upper Body Arm are in the indicated location.**

Slide the Right Upper Body Arm (9) onto the Right Upper Body Leg (31). Attach the Right Upper Body Arm with two M6 x 38mm Button Bolts (76) and two M6 Locknuts (77); **make sure that the Locknuts are inside the hexagonal holes.**

Repeat this step for the Left Upper Body Arm (8) and the Left Upper Body Leg (6).

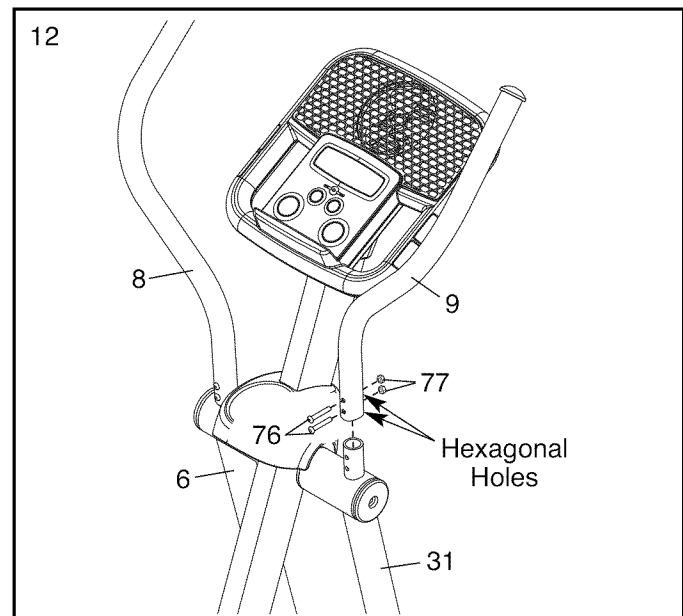

13. **Make sure that all parts of the elliptical exerciser are properly tightened.** Note: Some hardware may be left over after assembly is completed. To protect the floor or carpet from damage, place a mat under the elliptical exerciser.

HOW TO USE THE ELLIPTICAL EXERCISER

HOW TO MOVE THE ELLIPTICAL EXERCISER

Due to the size and weight of the elliptical exerciser, moving it requires two persons. Stand in front of the elliptical exerciser, hold the upright, and place one foot against one of the front wheels. **IMPORTANT: Do not place your foot on the ramp cover.** Pull on the upright and have a second person lift the base until the elliptical exerciser will roll on the front wheels. Carefully move the elliptical exerciser to the desired location, and then lower it to the floor.

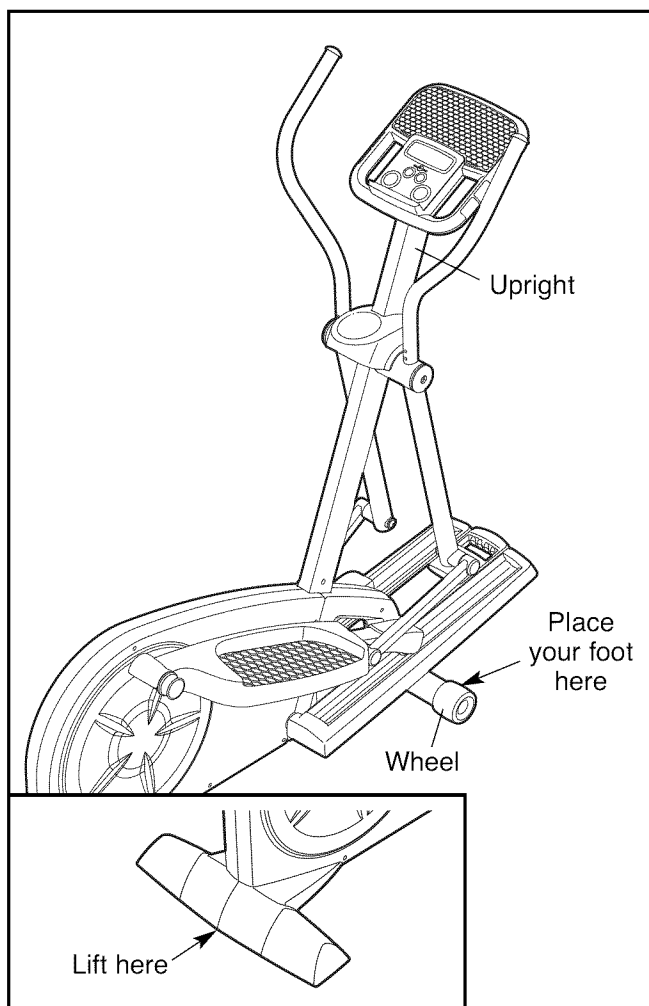

HOW TO EXERCISE ON THE ELLIPTICAL EXERCISER

To mount the elliptical exerciser, hold the upper body arms and step onto the pedal that is in the lowest position. Next, step onto the other pedal. Push the pedals until they begin to move with a continuous motion. **Note: The crank arms can turn in either direction. It is recommended that you turn the crank arms in the direction shown by the arrow below; however, for variety you can turn the crank arms in the opposite direction.**

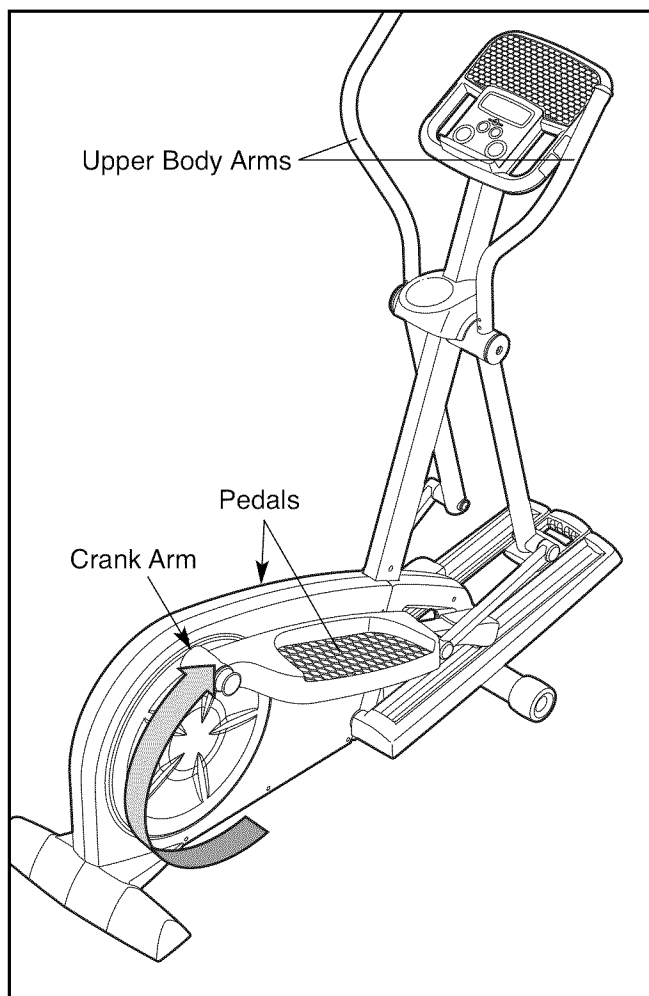

To dismount the elliptical exerciser, wait until the pedals come to a complete stop. **Note: The elliptical exerciser does not have a free wheel; the pedals will continue to move until the flywheel stops.** When the pedals are stationary, step off the higher pedal first. Then, step off the lower pedal.

HOW TO CHANGE THE INCLINE OF THE RAMP

To vary the motion of the pedals, you can change the incline of the ramp. To change the incline, pull the ramp handle outward, raise or lower the ramp, and engage the ramp pin into one of the adjustment holes in the front of the frame.

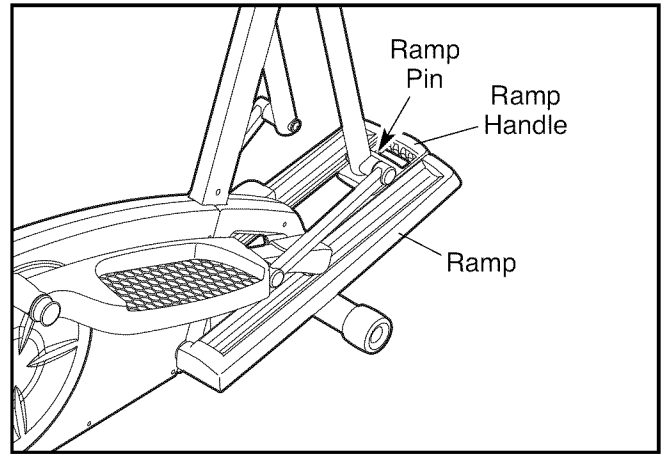

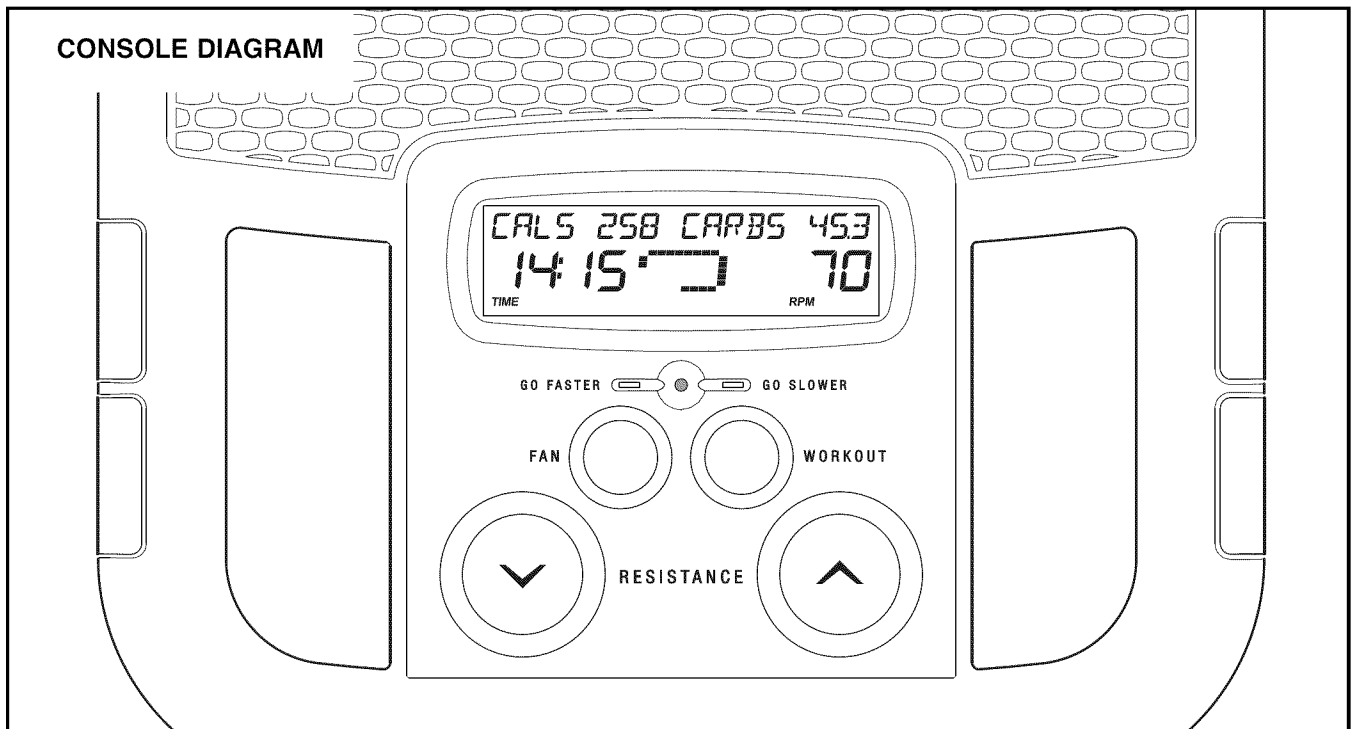

FEATURES OF THE CONSOLE

The advanced console offers an array of features designed to make your workouts more effective and enjoyable.

When you use the manual mode of the console, you can change the resistance of the pedals with the touch of a button. As you exercise, the console will display continuous exercise feedback. You can even measure your heart rate using the handgrip pulse sensor.

The console offers three interactive cross training workouts designed to help you to burn calories and enhance your cardiovascular system while toning and strengthening your muscles. The cross training workouts automatically control the resistance of the pedals and prompt you to perform a variety of strength exercises during your workout. Note: The strength exercises require the use of dumbbells and an inflatable exercise ball (not included). **To purchase dumbbells or an exercise ball, call 1-888-533-1333.**

The console also offers two target toning workouts designed to work specific areas of the body. The console guides you through each workout with a variety of exercise instructions while automatically changing the resistance of the pedals.

In addition, you can use three calorie goal workouts designed to help you burn 300 or 400 calories in 30- or 45-minute workouts. The calorie goal workouts automatically control the resistance of the pedals and prompt you to vary your pace while counting the calories you burn.

The console also has a high performance workout that automatically changes the resistance of the pedals and prompts you to vary your pace as it guides you through an effective workout.

To use the manual mode, see page 15. To use a cross training workout, see page 16. To use a target toning workout, see page 18. To use a calorie goal workout, see page 19. To use the high performance workout, see page 20.

HOW TO USE THE MANUAL MODE

Note: If there is a sheet of clear plastic on the face of the console, remove the plastic.

1. **Press the Resistance decrease button or begin pedaling to turn on the console.**

A moment after you turn on the console, the displays will light.

2. **Select the manual mode.**

Each time you turn on the console, the manual mode will be selected automatically. If you have selected a workout, reselect the manual mode by pressing the Workout button repeatedly until the words MANUAL MODE appear in the upper display.

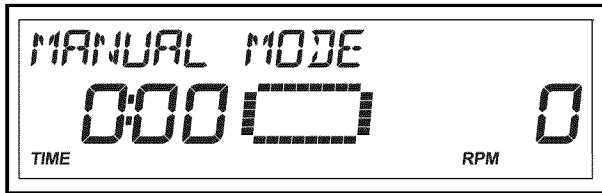

3. **Begin pedaling and change the resistance of the pedals as desired.**

As you pedal, change the resistance of the pedals by pressing the Resistance increase and decrease buttons repeatedly. There are ten resistance levels. Note: After you press the buttons, it will take a moment for the pedals to reach the selected resistance level.

4. **Follow your progress with the displays.**

The left display—This display will show the elapsed time. Note: When you select a workout, the display will show the time remaining in the workout instead of the elapsed time.



The left display will also show your heart rate when you use the handgrip pulse sensor (see step 5 on page 16).

When you select a workout, the left display will also show the approximate number of calories you have burned.

The center display—

When you select the manual mode, the center display will show a track that represents 640 revolutions. As you exercise, indicators will appear in succession around the track until the entire track appears. The track will then disappear and the indicators will again begin to appear in succession.

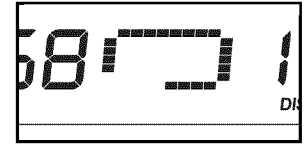

The center display will also show the resistance level of the pedals for a few seconds each time the resistance level changes.

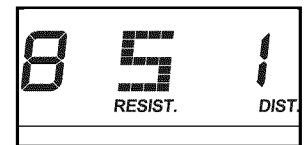

The right display—

This display will show the distance (total revolutions) you have pedaled and your pedaling pace, in revolutions per minute (rpm).

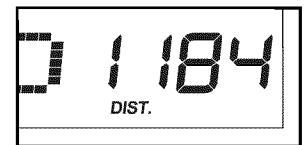

The upper display—When you select the manual mode, the upper display will show the approximate number of calories you have burned and the approximate number of grams of carbs you have burned.



5. Measure your heart rate if desired.

If there are sheets of clear plastic on the metal contacts on the handgrip pulse sensor, remove the plastic. To measure your heart rate, hold the handgrip pulse sensor with your palms resting against the metal contacts. **Avoid moving your hands or gripping the contacts tightly.**

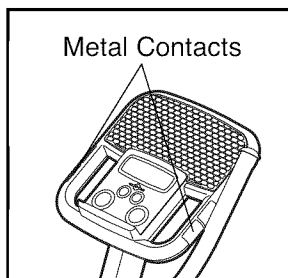

When your pulse is detected, a heart-shaped symbol will flash in the left display. Each time your heart beats, one or two

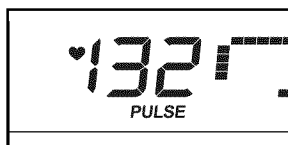

dashes will appear, and then your heart rate will be shown. For the most accurate heart rate reading, hold the contacts for at least 15 seconds. Note: If you continue to hold the handgrip pulse sensor, the display will show your heart rate for up to 30 seconds.

If your heart rate is not shown, make sure that your hands are positioned as described. Be careful not to move your hands excessively or to squeeze the metal contacts tightly. For optimal performance, clean the metal contacts using a soft cloth; **never use alcohol, abrasives, or chemicals to clean the contacts.**

6. Turn on the fan if desired.

The fan has high and low speed settings. Press the Fan button repeatedly to select a fan speed or to turn off the fan. Note: If the pedals do not move for about thirty seconds, the fan will turn off automatically.

7. When you are finished exercising, the console will turn off automatically.

If the pedals do not move for several seconds, a series of tones will sound, the console will pause, and the time will flash in the display.

If the pedals do not move for about five minutes, the console will turn off and the display will be reset.

HOW TO USE A CROSS TRAINING WORKOUT

1. Turn on the console.

See step 1 on page 15.

2. Select a cross training workout.

To select a cross training workout, press the Workout button repeatedly until the words UPPER BODY, LOWER BODY, or WHOLE BODY appear in the upper display.

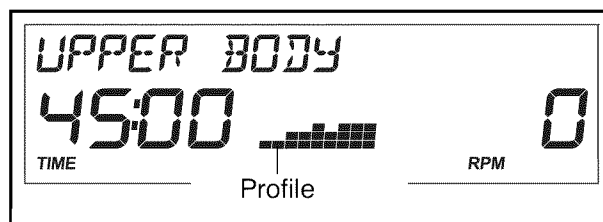

When you select a cross training workout, the name of the workout and the workout time will appear in the displays and a profile of the resistance levels of the workout will scroll across the center display.

3. Begin pedaling to start the workout.

Each workout is divided into 25 or 45 one-minute segments. One resistance level and one target rpm (revolutions per minute) setting are programmed for most segments. (Note: The same resistance level and/or target rpm setting may be programmed for consecutive segments.) During other segments, the console will prompt you to perform strength exercises.

During the workout, the workout profile will show your progress (see the drawing above). The flashing segment of the profile represents the current segment of the workout. The height of the flashing segment indicates the resistance level for the current segment. At the end of each segment of the workout, a series of tones will sound and the next segment of the profile will begin to flash. If a different resistance level is programmed for the next segment, the resistance level will appear in the display for a few seconds to alert you. The resistance of the pedals will then change.

As you exercise, you will be prompted to keep your pedaling pace near the target rpm setting for the current segment. When the words PEDAL FASTER appear in the upper display or the GO FASTER indicator on the pace guide is lit, increase your pace. When the words PEDAL SLOWER appear or the GO SLOWER indicator is lit, decrease your pace. When the words PEDALING IN RANGE appear or when the center indicator is lit, maintain your current pace.

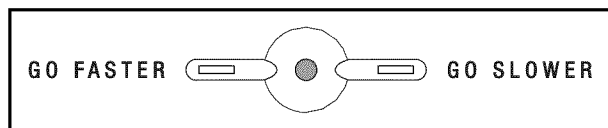

IMPORTANT: The target rpm settings are intended only to provide motivation. Your actual pace may be slower than the target rpm settings. Make sure to pedal at a pace that is comfortable for you.

If the resistance level for the current segment is too high or too low, you can manually override the setting by pressing the Resistance decrease and increase buttons. However, when the current segment ends, the pedals will automatically adjust to the resistance level for the next segment.

If you stop pedaling for several seconds, a series of tones will sound and the workout will pause. To restart the workout, simply resume pedaling. The workout will continue until the last segment of the profile flashes and the last segment of the workout ends.

4. Perform the first strength exercise when prompted.

When the first strength exercise segment begins, the name of the first strength exercise will appear in the upper display for a few seconds. The time will pause and flash in the left display.

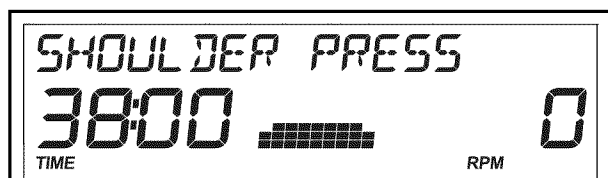

Next, the upper display will show the recommended number of repetitions for the first strength exercise.

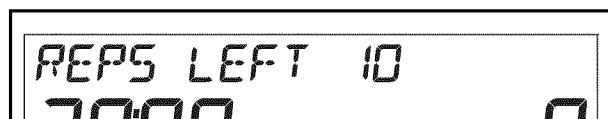

Step off the elliptical exerciser and prepare to begin the first strength exercise. Every few seconds, the console will sound a tone; when a tone sounds, perform one repetition of the exercise. Exercise with a slow, steady motion; do not perform more than one repetition each time a tone sounds. The display will count down the repetitions as you perform them.

Note: Refer to a weight training manual or exercise guide if you are unfamiliar with the correct form for each strength exercise. When performing lunges, alternate legs with each repetition. When performing dumbbell rows, perform half the repetitions with your right arm and half the repetitions with your left arm. The strength exercises require the use of dumbbells and an inflatable exercise ball (not included). **To purchase dumbbells or an exercise ball, call 1-888-533-1333.**

5. Continue the cross training workout.

When you have performed the recommended number of repetitions, the words START PEDALING will appear in the upper display. To continue the cross training workout, step onto the elliptical exerciser and start pedaling. The pedals will automatically adjust to the resistance level for the next segment.

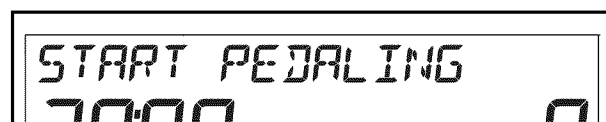

The workout will continue in this way until the last segment ends. Then, the words PROGRAM DONE will appear in the upper display.

6. Follow your progress with the displays.

See step 4 on page 15.

7. Measure your heart rate if desired.

See step 5 on page 16.

8. Turn on the fan if desired.

See step 6 on page 16.

9. When you are finished exercising, the console will turn off automatically.

See step 7 on page 16.

HOW TO USE A TARGET TONING WORKOUT

1. Turn on the console.

See step 1 on page 15.

2. Select a target toning workout.

To select a target toning workout, press the Workout button repeatedly until the words TARGET TONING 1 or TARGET TONING 2 appear in the upper display.

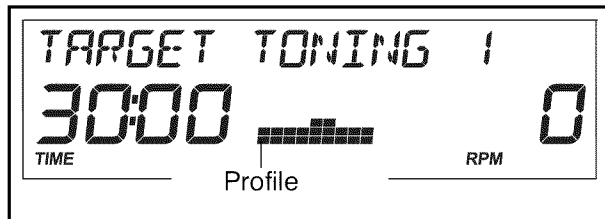

When you select a target toning workout, the name of the workout and the workout time will appear in the displays and a profile of the resistance levels of the workout will scroll across the center display.

3. Begin pedaling to start the workout.

Each workout is divided into 30 one-minute segments. One resistance level and one target rpm (revolutions per minute) setting are programmed for each segment. Note: The same resistance level and/or target rpm setting may be programmed for consecutive segments.

During the workout, the workout profile will show your progress (see the drawing above). The flashing segment of the profile represents the current segment of the workout. The height of the flashing segment indicates the resistance level for the current segment. At the end of each segment of the workout, a series of tones will sound and the next segment of the profile will begin to flash. If a different resistance level is programmed for the next segment, the resistance level will appear in the display for a few seconds to alert you. The resistance of the pedals will then change.

As you exercise, the console will display a variety of exercise instructions that will help you get the most benefit from your workout. For example, the console may instruct you to PEDAL BACKWARD, USE UPPER BODY, or FOCUS LOWER BODY during certain segments of the workout.

As you exercise, you will be prompted to keep your pedaling pace near the target rpm setting for the current segment. When the words PEDAL FASTER appear in the upper display or the GO FASTER indicator on the pace guide is lit, increase your pace. When the words PEDAL SLOWER appear or the GO SLOWER indicator is lit, decrease your pace. When the words PEDALING IN RANGE appear or when the center indicator is lit, maintain your current pace.

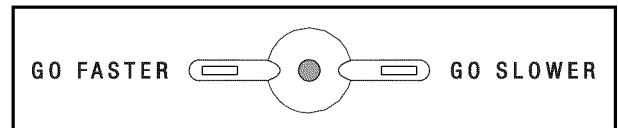

IMPORTANT: The target rpm settings are intended only to provide motivation. Your actual pace may be slower than the target rpm settings. Make sure to pedal at a pace that is comfortable for you.

If the resistance level for the current segment is too high or too low, you can manually override the setting by pressing the Resistance decrease and increase buttons. However, when the current segment ends, the pedals will automatically adjust to the resistance level for the next segment.

If you stop pedaling for several seconds, a series of tones will sound and the workout will pause. To restart the workout, simply resume pedaling. The workout will continue until the last segment of the profile flashes and the last segment of the workout ends.

When the last segment of the workout ends, the words PROGRAM DONE will appear in the upper display.

4. Follow your progress with the displays.

See step 4 on page 15.

5. Measure your heart rate if desired.

See step 5 on page 16.

6. Turn on the fan if desired.

See step 6 on page 16.

7. When you are finished exercising, the console will turn off automatically.

See step 7 on page 16.

HOW TO USE A CALORIE GOAL WORKOUT

1. Turn on the console.

See step 1 on page 15.

2. Select a calorie goal workout.

Press the Workout button repeatedly until the name of the desired calorie goal workout appears in the upper display. When you select a calorie goal workout, the name of the workout and the workout time will appear in the displays and a profile of the resistance levels of the workout will scroll across the center display.

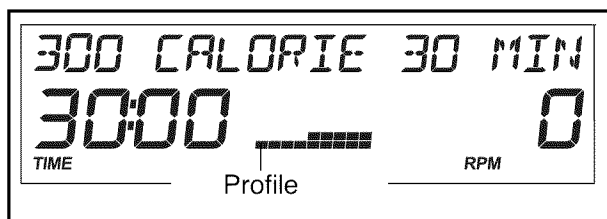

3. Begin pedaling to start the workout.

Each workout is divided into 30 or 45 one-minute segments. One resistance level and one target rpm (revolutions per minute) setting are programmed for each segment. Note: The same resistance level and/or target rpm setting may be programmed for consecutive segments. The displays for a calorie goal workout will work in the same way as the displays for a cross training workout (see step 3 on page 16).

As you exercise, you will be prompted to keep your pedaling pace near the target rpm setting for the current segment. When the words PEDAL FASTER appear in the upper display or the GO FASTER indicator on the pace guide is lit, increase your pace. When the words PEDAL SLOWER appear or the GO SLOWER indicator is lit, decrease your pace. When the words PEDALING IN RANGE appear or when the center indicator is lit, maintain your current pace.

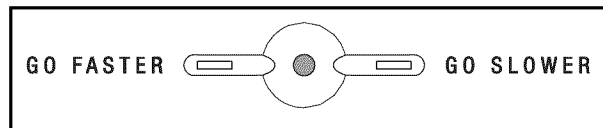

IMPORTANT: The target rpm settings are intended only to provide motivation. Your actual pace may be slower than the target rpm settings. Make sure to pedal at a pace that is comfortable for you. Note: If you manually override the resistance settings of a calorie goal workout, you may not reach your calorie goal.

If you stop pedaling for several seconds, a series of tones will sound and the workout will pause. To restart the workout, simply resume pedaling. The workout will continue until the last segment of the profile flashes and the last segment of the workout ends.

When the last segment of the workout ends, the words PROGRAM DONE will appear in the upper display.

4. Follow your progress with the displays.

See step 4 on page 15.

5. Measure your heart rate if desired.

See step 5 on page 16.

6. Turn on the fan if desired.

See step 6 on page 16.

7. When you are finished exercising, the console will turn off automatically.

See step 7 on page 16.

HOW TO USE THE HIGH PERFORMANCE WORKOUT

1. Turn on the console.

See step 1 on page 15.

2. Select the high performance workout.

Press the Workout button repeatedly until the words HIGH PERFORMANCE appear in the upper display. The workout time will appear in the left display and a profile of the resistance levels for the workout will scroll across the center display.

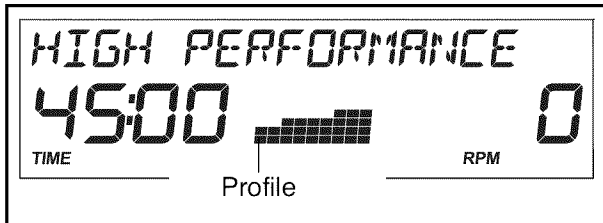

3. Begin pedaling to start the workout.

The workout is divided into 45 one-minute segments. One resistance level and one target rpm setting are programmed for each segment. Note: The same resistance level and/or target rpm (revolutions per minute) setting may be programmed for consecutive segments. The displays for the high performance workout will work in the same way as the displays for a cross training workout (see step 3 on page 16).

As you exercise, you will be prompted to keep your pedaling pace near the target rpm setting for the current segment. When the words PEDAL FASTER appear in the upper display or the GO FASTER indicator on the pace guide is lit, increase your pace. When the words PEDAL SLOWER appear or the GO SLOWER indicator is lit, decrease your pace. When the words PEDALING IN RANGE appear or when the center indicator is lit, maintain your current pace.

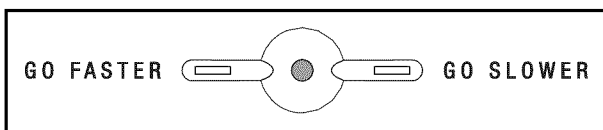

IMPORTANT: The target rpm settings are intended only to provide motivation. Your actual pace may be slower than the target rpm settings. Make sure to pedal at a pace that is comfortable for you.

If you stop pedaling for several seconds, a series of tones will sound and the workout will pause. To restart the workout, simply resume pedaling. The workout will continue until the last segment of the profile flashes and the last segment of the workout ends.

When the last segment of the workout ends, the words PROGRAM DONE will appear in the upper display.

4. Follow your progress with the displays.

See step 4 on page 15.

5. Measure your heart rate if desired.

See step 5 on page 16.

6. Turn on the fan if desired.

See step 6 on page 16.

7. When you are finished exercising, the console will turn off automatically.

See step 7 on page 16.

MAINTENANCE AND TROUBLESHOOTING

Inspect and tighten all parts of the elliptical exerciser regularly. Replace any worn parts immediately.

To clean the elliptical exerciser, use a damp cloth and a small amount of mild soap. **IMPORTANT: To avoid damage to the console, keep liquids away from the console and keep the console out of direct sunlight.**

CONSOLE TROUBLESHOOTING

If the console displays become dim, the batteries should be replaced; most console problems are the result of low batteries. See assembly step 5 on page 8 for replacement instructions. If the handgrip pulse sensor does not function properly, see step 5 on page 16.

HOW TO ADJUST THE REED SWITCH

If the console does not display correct feedback, the reed switch should be adjusted. First, remove all of the screws from both shields; **there are three sizes of screws in the shields—note which size of screw you remove from each hole.** Then, gently pry the shields away from the frame.

Next, locate the Reed Switch (58). Turn the Left Pedal Disc (26) until the Magnet (41) is aligned with the Reed Switch. Loosen, but do not remove, the indicated M4 x 16mm Screw

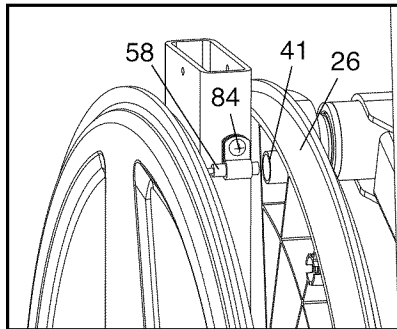

(84). Slide the Reed Switch slightly closer to or away from the Magnet, and then retighten the Screw. Rock the Left Pedal Disc forward and backward just enough that the Magnet passes the Reed Switch repeatedly. Repeat until the console displays correct feedback. When the Reed Switch is correctly adjusted, reattach the shields. Note: If you have questions as to which screw should be in which hole, see EXPLODED DRAWING B on page 27 and the PART LIST on page 24.

HOW TO ADJUST THE BELT

If you can feel the pedals slip while you are pedaling, even when the resistance of the pedals is at the highest setting, the Belt (46) may need to be adjusted. First, remove all the screws from both shields; **there are three sizes of screws in the shields—note which size of screw you remove from each hole.** Then, gently pry the shields away from the frame.

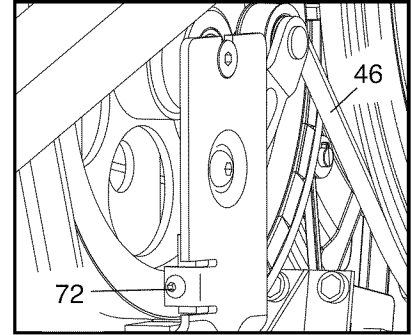

Next, turn the Belt Adjustment Screw (72) until the Belt (46) is tight. Then, reattach the shields. Note: If you have questions as to which screw should be in which hole, see EXPLODED DRAWING B on page 27 and the PART LIST on page 24.

EXERCISE GUIDELINES

⚠ WARNING: Before beginning this or any exercise program, consult your physician. This is especially important for persons over the age of 35 or persons with pre-existing health problems.

The pulse sensor is not a medical device. Various factors may affect the accuracy of heart rate readings. The pulse sensor is intended only as an exercise aid in determining heart rate trends in general.

These guidelines will help you to plan your exercise program. For detailed exercise information, obtain a reputable book or consult your physician. Remember, proper nutrition and adequate rest are essential for successful results.

EXERCISE INTENSITY

Whether your goal is to burn fat or to strengthen your cardiovascular system, exercising at the proper intensity is the key to achieving results. You can use your heart rate as a guide to find the proper intensity level. The chart below shows recommended heart rates for fat burning and aerobic exercise.

165	155	145	140	130	125	115	♥
145	138	130	125	118	110	103	♥
125	120	115	110	105	95	90	♥
<hr/>							
20	30	40	50	60	70	80	

To find the proper intensity level, find your age at the bottom of the chart (ages are rounded off to the nearest ten years). The three numbers listed above your age define your “training zone.” The lowest number is the heart rate for fat burning, the middle number is the heart rate for maximum fat burning, and the highest number is the heart rate for aerobic exercise.

Burning Fat—To burn fat effectively, you must exercise at a low intensity level for a sustained period of time. During the first few minutes of exercise, your body uses *carbohydrate calories* for energy. Only after the first few minutes of exercise does your body begin to use stored *fat calories* for energy. If your goal is to burn fat, adjust the intensity of your exercise until your heart rate is near the lowest number in your training zone. For maximum fat burning, exercise with your heart rate near the middle number in your training zone.

Aerobic Exercise—If your goal is to strengthen your cardiovascular system, you must perform aerobic exercise, which is activity that requires large amounts of oxygen for prolonged periods of time. For aerobic exercise, adjust the intensity of your exercise until your heart rate is near the highest number in your training zone.

WORKOUT GUIDELINES

Warming Up—Start with 5 to 10 minutes of stretching and light exercise. A warm-up increases your body temperature, heart rate, and circulation in preparation for exercise.

Training Zone Exercise—Exercise for 20 to 30 minutes with your heart rate in your training zone. (During the first few weeks of your exercise program, do not keep your heart rate in your training zone for longer than 20 minutes.) Breathe regularly and deeply as you exercise—never hold your breath.

Cooling Down—Finish with 5 to 10 minutes of stretching. Stretching increases the flexibility of your muscles and helps to prevent post-exercise problems.

EXERCISE FREQUENCY

To maintain or improve your condition, complete three workouts each week, with at least one day of rest between workouts. After a few months of regular exercise, you may complete up to five workouts each week, if desired. Remember, the key to success is to make exercise a regular and enjoyable part of your everyday life.

SUGGESTED STRETCHES

The correct form for several basic stretches is shown at the right. Move slowly as you stretch—never bounce.

1. Toe Touch Stretch

Stand with your knees bent slightly and slowly bend forward from your hips. Allow your back and shoulders to relax as you reach down toward your toes as far as possible. Hold for 15 counts, then relax. Repeat 3 times. Stretches: Hamstrings, back of knees, and back.

2. Hamstring Stretch

Sit with one leg extended. Bring the sole of the opposite foot toward you and rest it against the inner thigh of your extended leg. Reach toward your toes as far as possible. Hold for 15 counts, then relax. Repeat 3 times for each leg. Stretches: Hamstrings, lower back, and groin.

3. Calf/Achilles Stretch

With one leg in front of the other, reach forward and place your hands against a wall. Keep your back leg straight and your back foot flat on the floor. Bend your front leg, lean forward and move your hips toward the wall. Hold for 15 counts, then relax. Repeat 3 times for each leg. To cause further stretching of the achilles tendons, bend your back leg as well. Stretches: Calves, achilles tendons, and ankles.

4. Quadriceps Stretch

With one hand against a wall for balance, reach back and grasp one foot with your other hand. Bring your heel as close to your buttocks as possible. Hold for 15 counts, then relax. Repeat 3 times for each leg. Stretches: Quadriceps and hip muscles.

5. Inner Thigh Stretch

Sit with the soles of your feet together and your knees outward. Pull your feet toward your groin area as far as possible. Hold for 15 counts, then relax. Repeat 3 times. Stretches: Quadriceps and hip muscles.

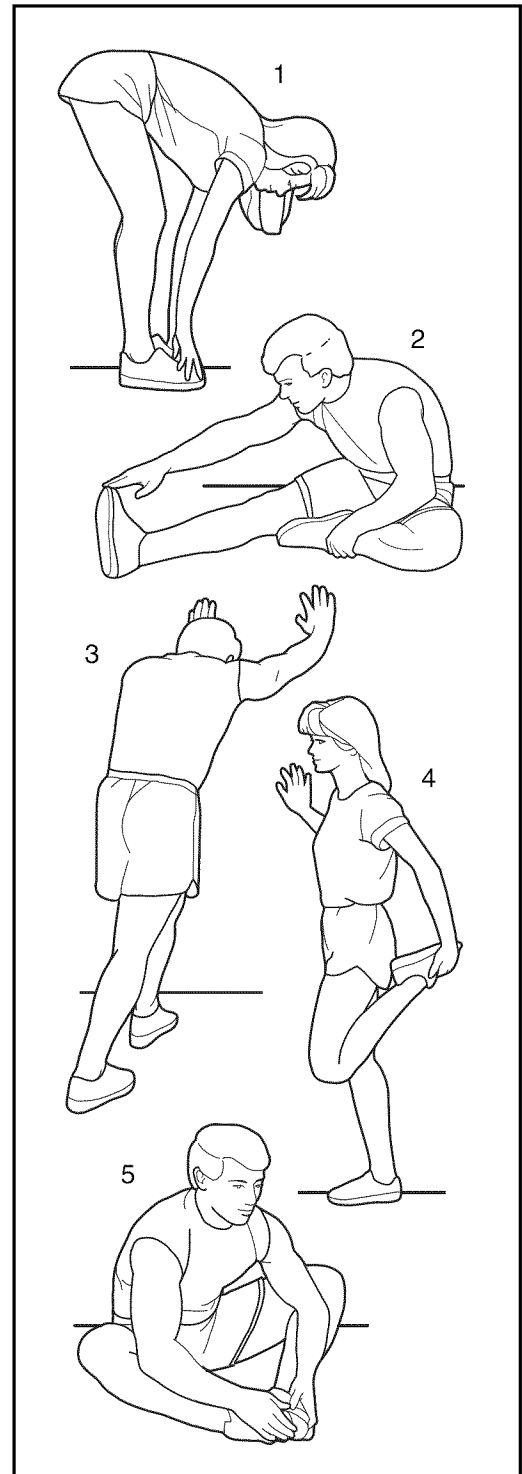

PART LIST—Model No. 831.23844.0

R0708B

Key No.	Qty.	Description	Key No.	Qty.	Description
1	1	Frame	51	1	Flywheel
2	1	Upright	52	1	Idler
3	1	Console Bracket	53	1	C-magnet
4	1	Console	54	1	Resistance Motor
5	1	Water Bottle Holder	55	1	Motor Bracket
6	1	Left Upper Body Leg	56	1	Resistance Arm
7	1	Idler Wheel	57	1	Clamp
8	1	Left Upper Body Arm	58	1	Reed Switch/Wire
9	1	Right Upper Body Arm	59	1	Magnet Spacer
10	2	Foam Grip	60	1	Key
11	2	Upper Cap	61	1	Square Nut
12	1	Left Pedal	62	1	Button Screw
13	1	Right Pedal	63	2	M10 x 41mm Shoulder Patch Screw
14	2	Pedal Arm	64	1	Flywheel Bolt
15	2	Pedal Bracket	65	1	C-magnet Bolt
16	1	Pivot Axle	66	1	Idler Bolt
17	2	Inner Bushing Set	67	1	Key Screw
18	2	Outer Bushing Set	68	1	Crank Arm Screw
19	10	Upright Bushing	69	4	Resistance Motor Bolt
20	2	Large Axle Cover	70	4	Resistance Motor Nut
21	2	Pedal Arm Axle	71	5	Motor Bracket Screw
22	4	Axle Cover	72	1	Belt Adjustment Screw
23	2	Roller Cover	73	2	M8 x 58mm Shoulder Bolt
24	1	Crank Assembly	74	4	M8 Locknut
25	1	Crank Arm	75	6	M10 x 70mm Patch Screw
26	1	Left Pedal Disc	76	4	M6 x 38mm Button Bolt
27	1	Right Pedal Disc	77	4	M6 Locknut
28	1	Pedal Disc Cover	78	10	M10 Split Washer
29	4	Bracket Bearing	79	4	M10 x 20mm Patch Screw
30	1	Tree Fastener	80	6	M6 x 16mm Patch Screw
31	1	Right Upper Body Leg	81	4	M8 x 12mm Button Screw
32	2	M8 x 18mm Hex Screw	82	1	M10 Locknut
33	2	M10 Washer	83	9	M6 Star Washer
34	1	M4 x 13mm Screw	84	39	M4 x 16mm Screw
35	2	Pedal Arm Bracket	85	2	Flywheel Spacer
36	2	Bracket Cover	86	4	M8 Washer
37	2	M10 x 16mm Button Screw	87	2	M5 x 30mm Screw
38	2	Crank Bearing	88	6	Wave Washer
39	1	Crank Spacer	89	12	M4 Washer
40	1	Crank Arm Spacer	90	10	M6 Large Washer
41	2	Magnet	91	3	M4 x 48mm Screw
42	1	Left Front Shield	92	16	M4 x 25mm Screw
43	1	Right Front Shield	93	2	M4 x 35mm Screw
44	1	Left Shield	94	4	M4 x 16mm Flat Head Screw
45	1	Right Shield	95	2	M4 x 32mm Screw
46	1	Belt	96	1	Console Cover
47	2	Foot	97	4	Roller Bushing
48	1	Left Frame Cover	98	9	M5 x 12mm Screw
49	1	Right Frame Cover	99	1	M3.5 x 12mm Screw
50	2	Wheel			

Key No.	Qty.	Description	Key No.	Qty.	Description
100	1	Wire Harness	110	1	Ramp Lock Bushing
101	1	Extended Reed Switch Wire	111	6	Ramp Bushing
102	2	M8 x 50mm Bolt Set	112	1	Ramp Axle
103	1	Ramp Cover	113	2	Upper Body Leg Spacer
104	1	Ramp	114	2	Pedal Leg Spacer
105	1	Top Ramp Handle	115	2	Roller
106	1	Bottom Ramp Handle	*	–	User's Manual
107	1	Ramp Lock Shaft	*	–	Hex Key
108	1	Ramp Lock Spring	*	–	Grease Packet
109	1	Ramp Lock Pin			

Note: Specifications are subject to change without notice. See the back cover of this manual for information about ordering replacement parts. *These parts are not illustrated. **If a part is missing, call 1-888-533-1333.**

EXPLODED DRAWING A—Model No. 831.23844.0

R0708B

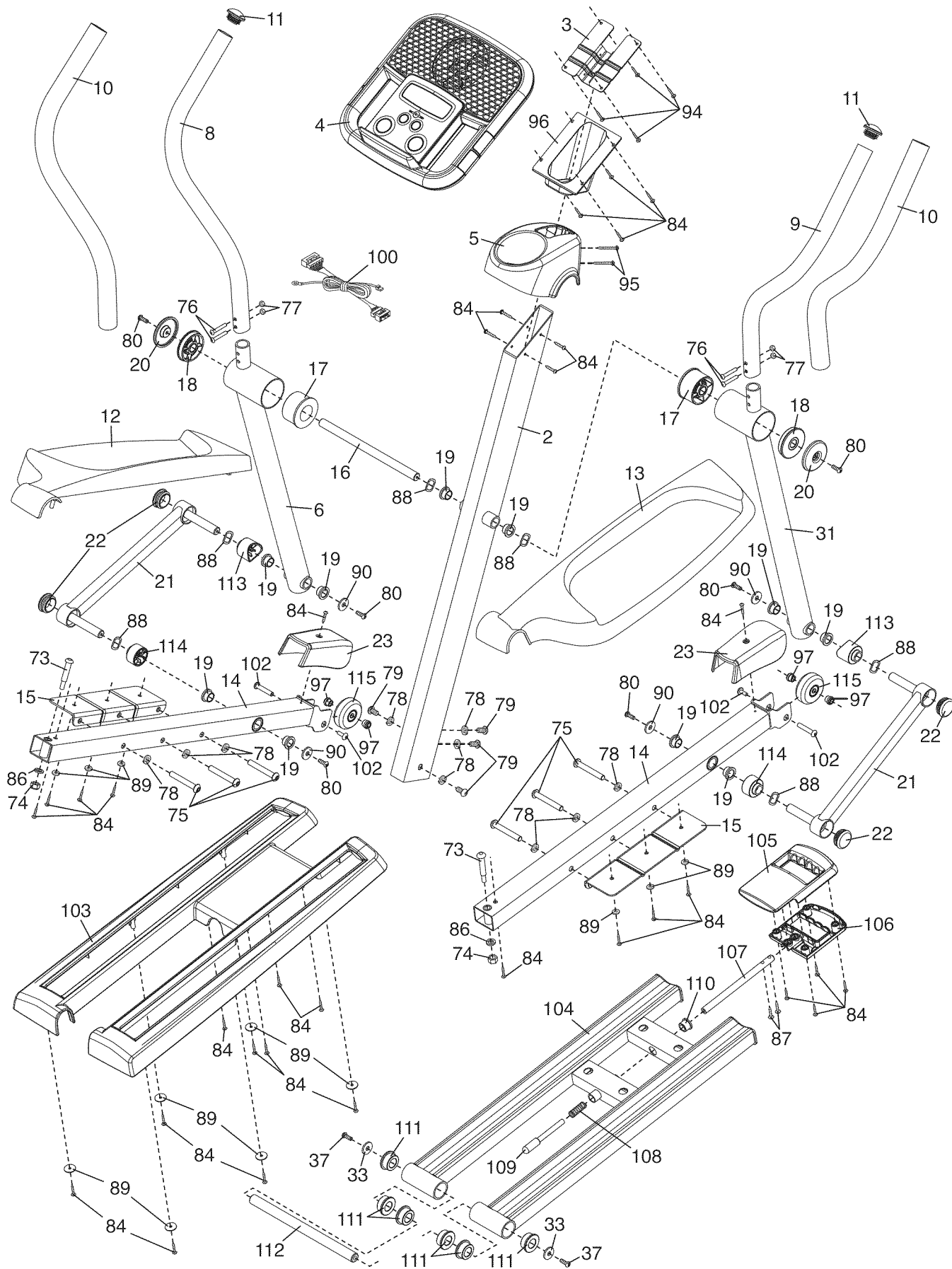

EXPLODED DRAWING B—Model No. 831.23844.0

R0708B

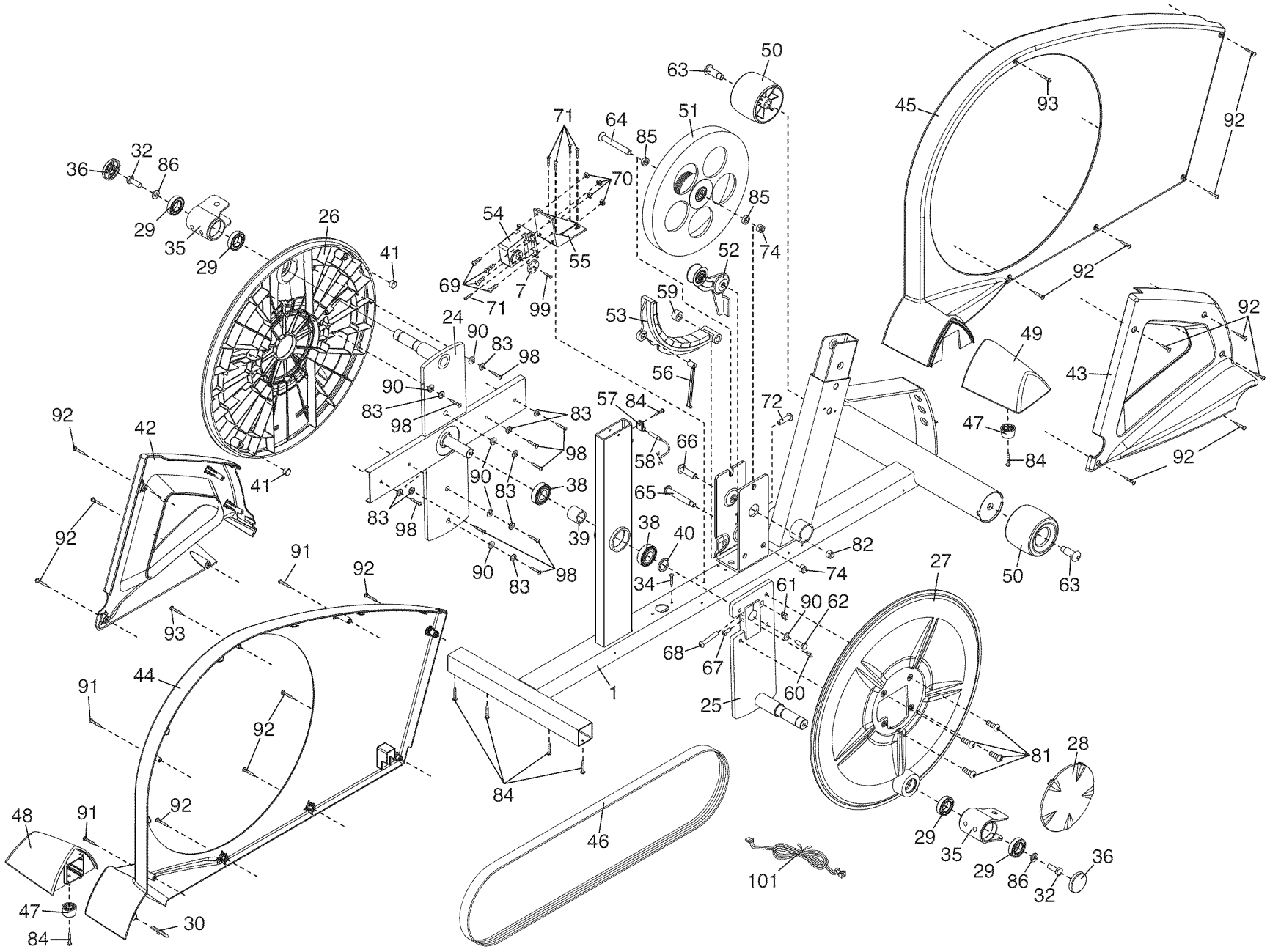

Get it fixed, at your home or ours!

Your Home

For repair—**in your home**—of **all** major brand appliances, lawn and garden equipment, or heating and cooling systems, **no matter who made it, no matter who sold it!**

For the replacement parts, accessories, and user's manuals that you need to do-it-yourself.

For Sears professional installation of home appliances and items like garage door openers and water heaters.

1-800-4-MY-HOME® (1-800-469-4663)

Call anytime, day or night (U.S.A. and Canada)

www.sears.com

www.sears.ca

Our Home

For repair of carry-in items like vacuums, lawn equipment, and electronics, call or go on-line for the location of your nearest **Sears Parts & Repair Center.**

1-800-488-1222 Call anytime, day or night (U.S.A. only)

www.sears.com

To purchase a protection agreement (U.S.A.) or maintenance agreement (Canada) on a product serviced by Sears:

1-800-827-6655 (U.S.A.)

1-800-361-6665 (Canada)

Para pedir servicio de reparación a domicilio, y para ordenar piezas:

1-888-SU-HOGAR® (1-888-784-6427)



® Registered Trademark / ™ Trademark / ™ Service Mark of Sears Brands, LLC
® Marca Registrada / ™ Marca de Fábrica / ™ Marca de Servicio de Sears Brands, LLC

90 DAY FULL WARRANTY

If this Sears Elliptical Exerciser fails due to a defect in material or workmanship within 90 days of the date of purchase, call 1-800-4-MY-HOME® (1-800-469-4663) to arrange for free repair (or replacement if repair proves impossible). The frame is warranted for 7 years from the date of purchase.

This warranty does not apply when the Elliptical Exerciser is used commercially or for rental purposes.

This warranty gives you specific legal rights, and you may also have other rights which vary from state to state.

Sears, Roebuck and Co., Hoffman Estates, IL 60179

PRO-FORM XP™

THINLINE 480

Model No. 831.23844.0

Serial No. _____

Write the serial number in the space above for reference.

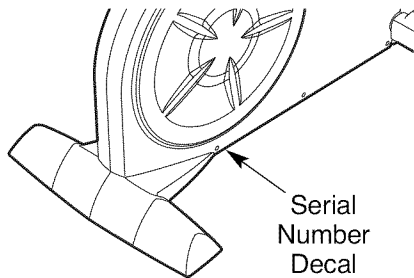

- Assembly
- Operation
- Maintenance
- Part List and Drawing

CAUTION

Read all precautions and instructions in this manual before using this equipment. Keep this manual for future reference.

ELLIPTICAL EXERCISER

User's Manual

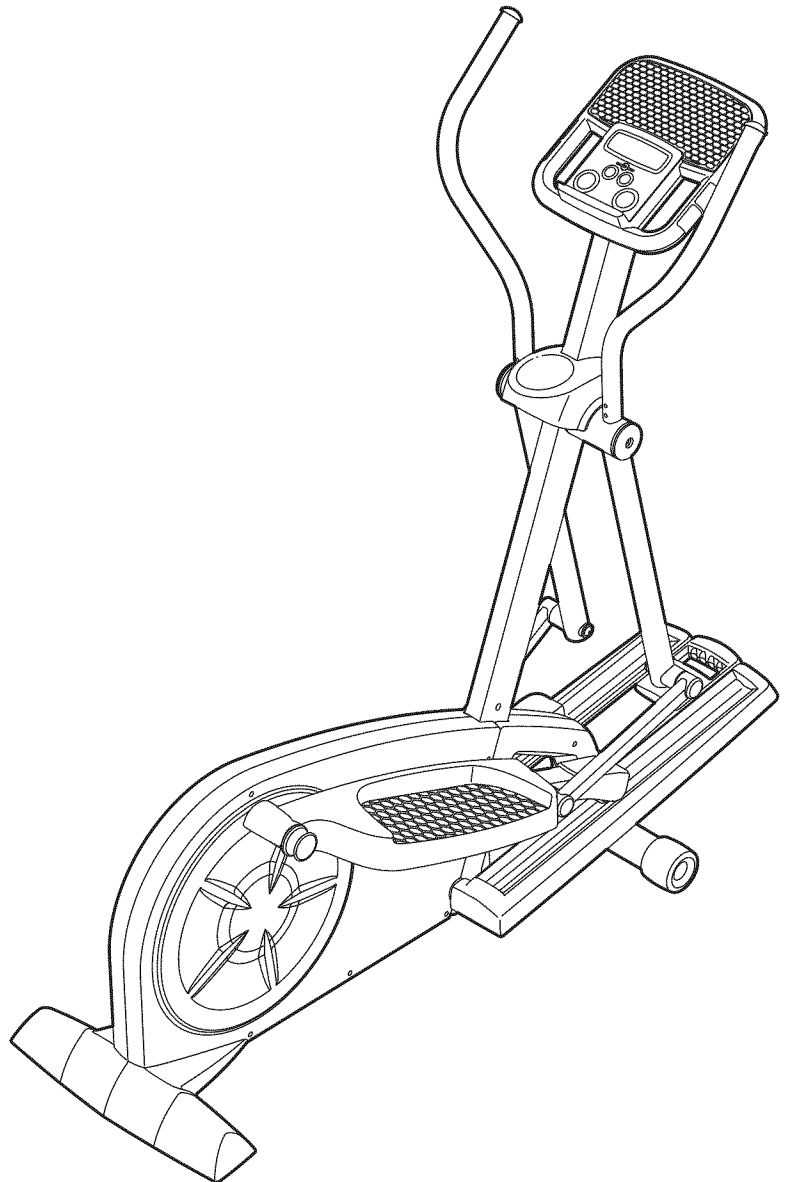

Sears, Roebuck and Co., Hoffman Estates, IL 60179

TABLE OF CONTENTS

WARNING DECAL PLACEMENT2
IMPORTANT PRECAUTIONS3
BEFORE YOU BEGIN4
ASSEMBLY5
HOW TO USE THE ELLIPTICAL EXERCISER12
MAINTENANCE AND TROUBLESHOOTING21
EXERCISE GUIDELINES22
PART LIST24
EXPLODED DRAWING26
ORDERING REPLACEMENT PARTSBack Cover
90 DAY FULL WARRANTYBack Cover

WARNING DECAL PLACEMENT

This drawing shows the location(s) of the warning decal(s). **If a decal is missing or illegible, call 1-888-533-1333 and request a free replacement decal. Apply the decal in the location shown.** Note: The decal(s) may not be shown at actual size.

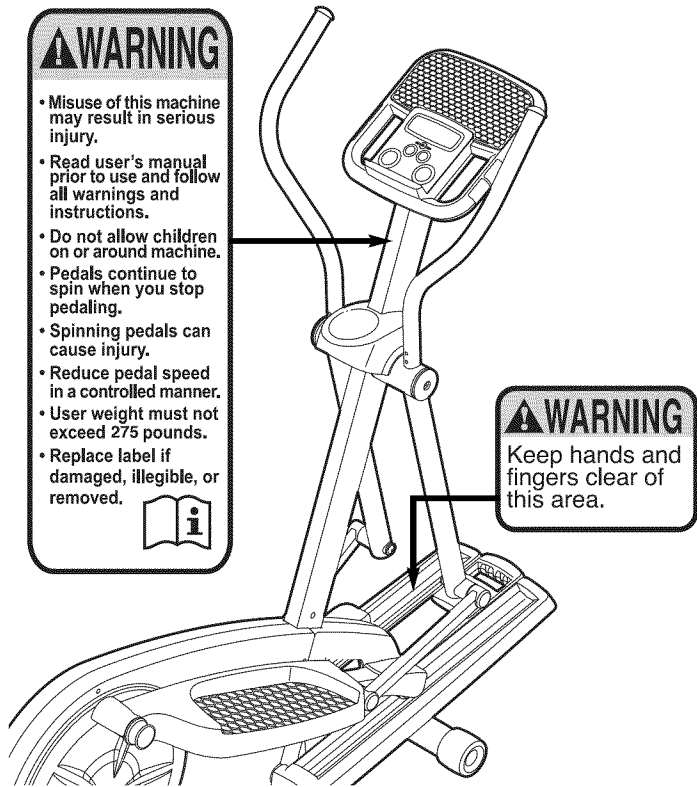

IMPORTANT PRECAUTIONS

⚠ WARNING: To reduce the risk of serious injury, read all important precautions and instructions in this manual and all warnings on your elliptical exerciser before using your elliptical exerciser. Sears assumes no responsibility for personal injury or property damage sustained by or through the use of this product.

1. Before beginning any exercise program, consult your physician. This is especially important for persons over the age of 35 or persons with pre-existing health problems.
2. It is the responsibility of the owner to ensure that all users of the elliptical exerciser are adequately informed of all precautions.
3. Your elliptical exerciser is intended for home use only. Do not use your elliptical exerciser in a commercial, rental, or institutional setting.
4. Keep your elliptical exerciser indoors, away from moisture and dust. Place your elliptical exerciser on a level surface, with a mat beneath it to protect the floor or carpet. Make sure that there is enough clearance around your elliptical exerciser to mount, dismount, and use it.
5. Inspect and properly tighten all parts regularly. Replace any worn parts immediately.
6. Keep children under age 12 and pets away from your elliptical exerciser at all times.
7. Your elliptical exerciser should not be used by persons weighing more than 275 lbs. (124 kg).
8. Wear appropriate exercise clothes when exercising; do not wear loose clothes that could become caught on your elliptical exerciser. Always wear athletic shoes for foot protection.
9. Hold the handgrip pulse sensor or the upper body arms when mounting, dismounting, or using your elliptical exerciser.
10. Keep your back straight while using your elliptical exerciser; do not arch your back.
11. The pulse sensor is not a medical device. Various factors, including the user's movement, may affect the accuracy of heart rate readings. The pulse sensor is intended only as an exercise aid in determining heart rate trends in general.
12. When you stop exercising, allow the pedals to slowly come to a stop.
13. If you feel pain or dizziness while exercising, stop immediately and cool down.
14. Use your elliptical exerciser only as described in this manual.

BEFORE YOU BEGIN

Thank you for purchasing the revolutionary PROFORM XP™ THINLINE 480 elliptical exerciser. The THINLINE 480 elliptical exerciser provides a wide array of features designed to make your workouts at home more effective and enjoyable.

For your benefit, read this manual carefully before you use the elliptical exerciser. If you have questions after reading this manual, please see the back

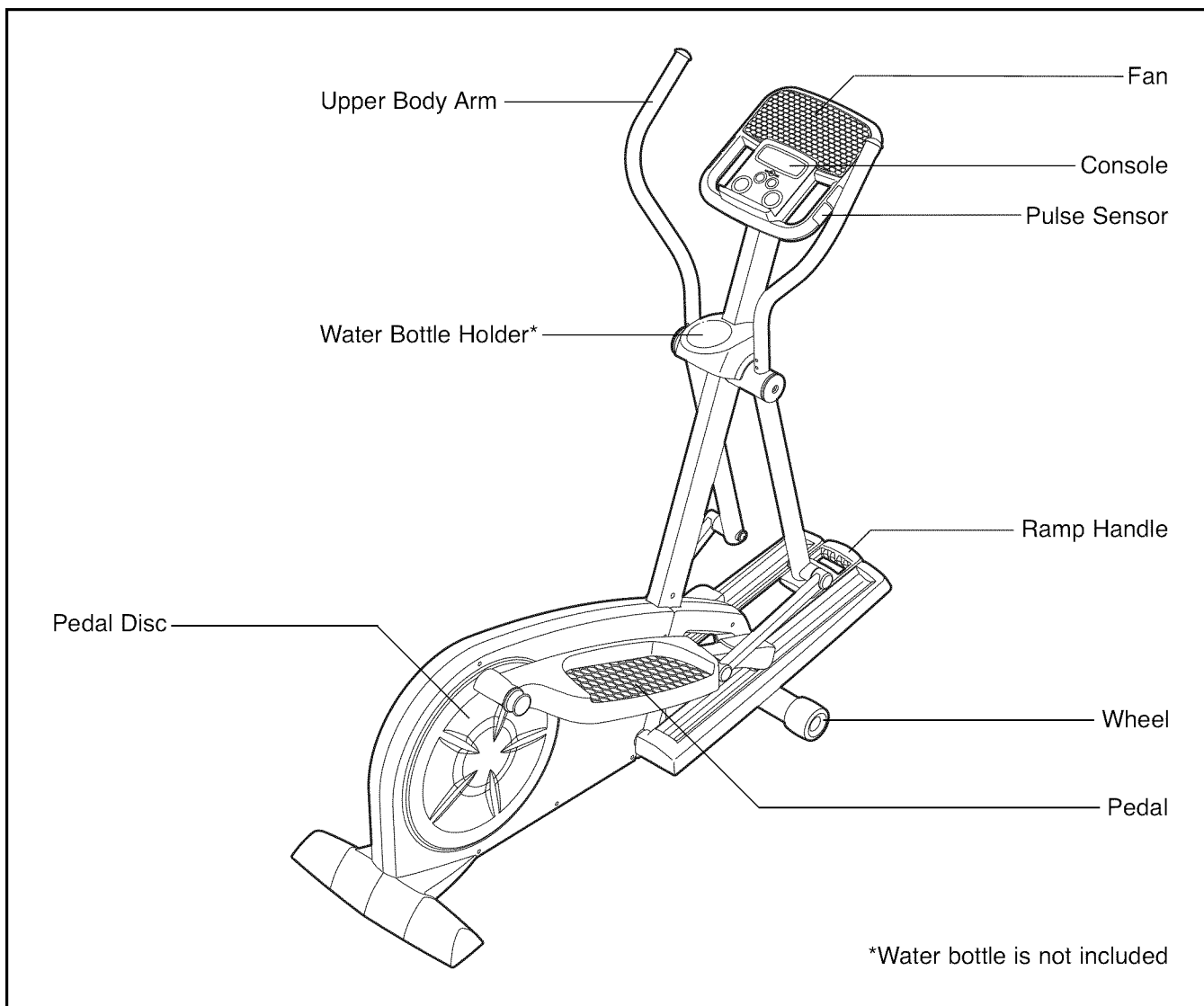

cover of this manual. To help us assist you, note the product model number and serial number before contacting us. The model number and the location of the serial number decal are shown on the front cover of this manual.

Before reading further, please familiarize yourself with the parts that are labeled in the drawing below.



ASSEMBLY

Assembly requires two persons. Place all parts of the elliptical exerciser in a cleared area and remove the packing materials. Do not dispose of the packing materials until assembly is completed.

Assembly requires the included tools and your own Phillips screwdriver  , adjustable wrench  , and rubber mallet  .

As you assemble the elliptical exerciser, use the drawings below to identify small parts. The number in parentheses below each drawing is the key number of the part, from the PART LIST near the end of this manual. The number following the parentheses is the quantity needed for assembly. **Note: Some small parts may have been preassembled. If a part is not in the parts bag, check to see if it has been preassembled. If a part is missing, call 1-888-533-1333.**

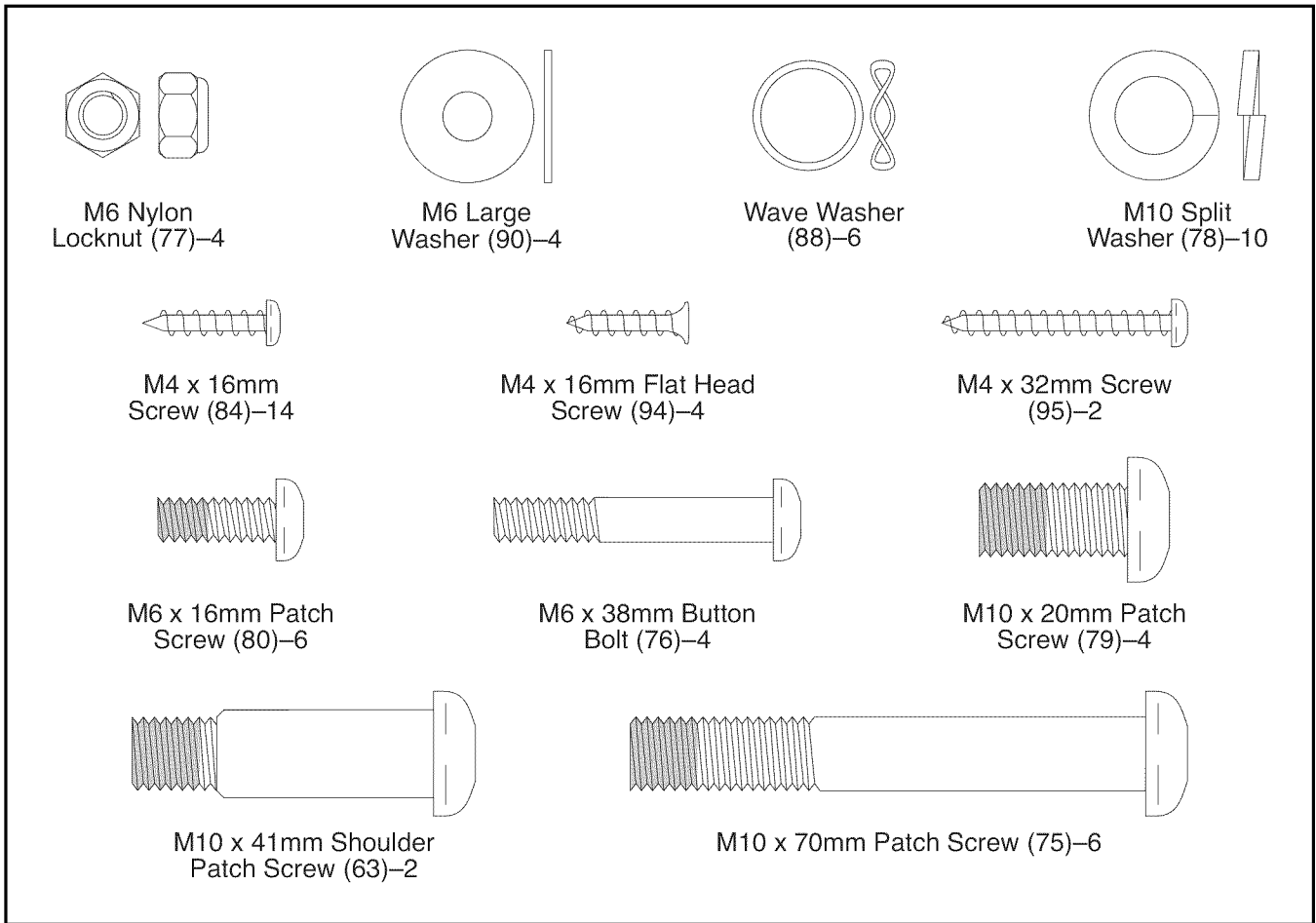

1.

To make assembly easier, read the information on page 5 before you begin assembling the elliptical exerciser.

Pull the ramp handle outward and lower the Ramp (104) until it rests on the Frame (1).

Attach a Wheel (50) to the front of the Frame (1) with an M10 x 41mm Shoulder Patch Screw (63).

Attach the other Wheel (not shown) in the same way.

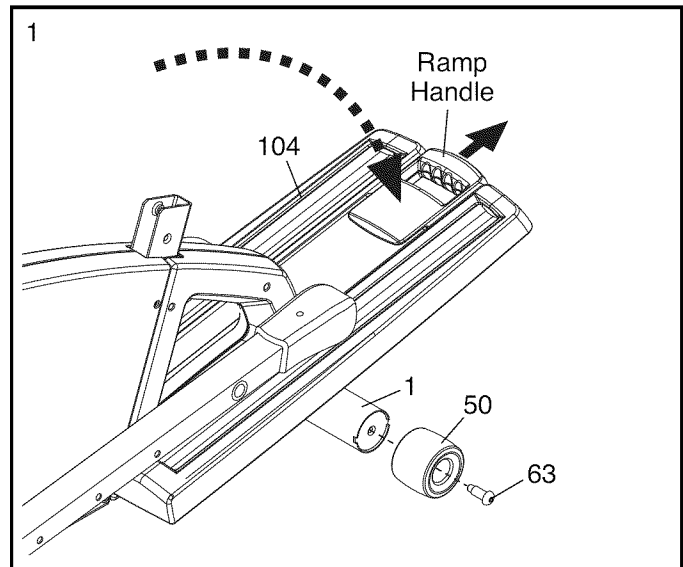

2. Identify the Right Frame Cover (49), which is marked with a "Right" sticker. Then, orient the Right Frame Cover with the rounded side in the indicated location. While another person lifts the rear of the Frame (1), attach the Right Frame Cover with two M4 x 16mm Screws (84).

Repeat this step for the Left Frame Cover (48).

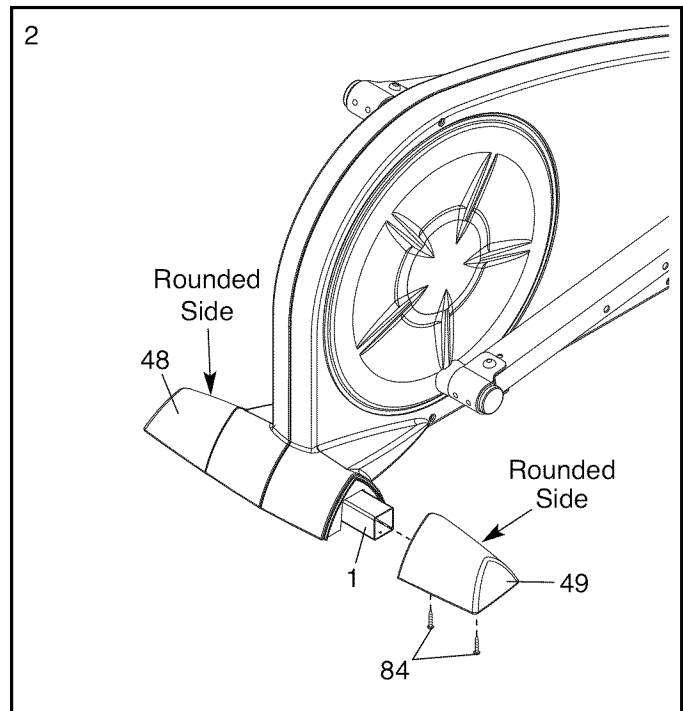

3. **Tip: Do not pinch the Wire Harness (100). Start all screws before tightening any of them.**

Have another person hold the Upright (2) near the Frame (1). Locate the wire tie in the Upright. Tie the lower end of the wire tie to the Wire Harness (100). Next, pull the upper end of the wire tie upward out of the top of the Upright. Then, untie and discard the wire tie. **Tip: To prevent the Wire Harness from falling inside the Upright, secure the Wire Harness with a rubber band.**

Attach the Upright (2) to the Frame (1) with four M10 x 20mm Patch Screws (79), and four M10 Split Washers (78). **Do not tighten the Patch Screws yet.**

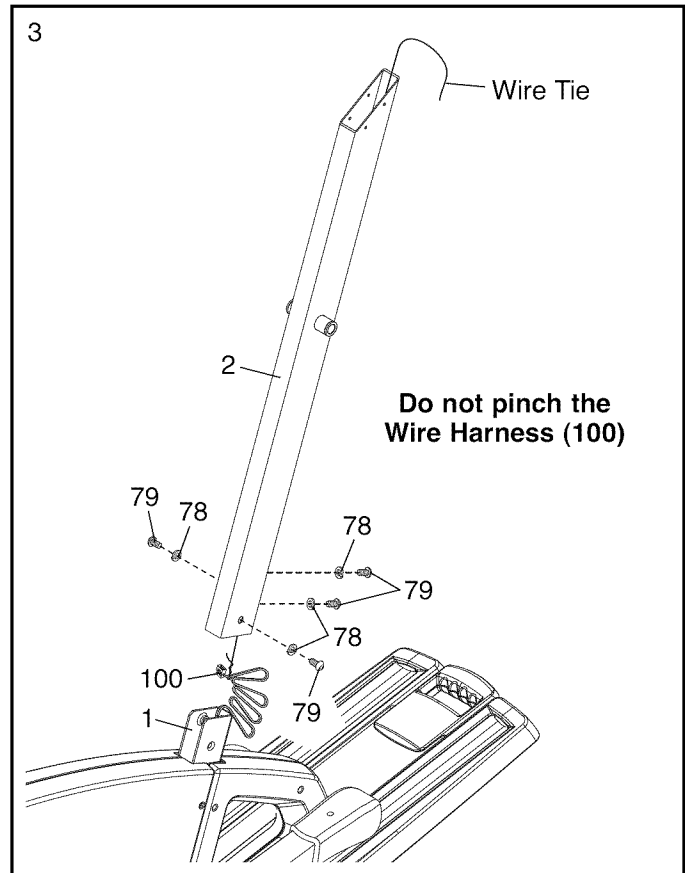

4. Orient the Water Bottle Holder (5) as shown and slide it onto the Upright (2). Attach the Water Bottle Holder with two M4 x 32mm Screws (95).

Tip: Do not pinch the Wire Harness (100). Slide the Console Cover (96) onto the Upright (2) and move it downward to the Water Bottle Holder. Then, insert the Console Bracket (3) into the top of the Upright. Attach the Console Bracket with four M4 x 16mm Screws (84).

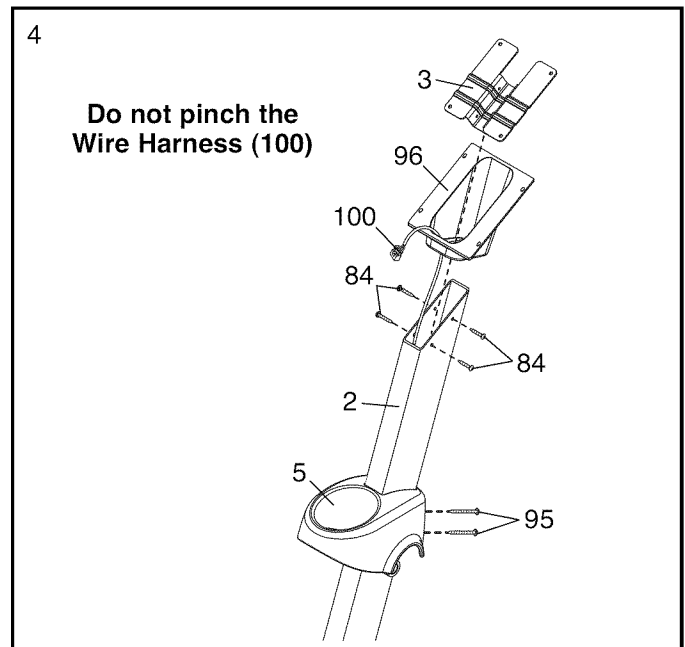

5. The Console (4) can use four 1.5V “D” batteries (not included); alkaline batteries are recommended. **IMPORTANT: If the Console has been exposed to cold temperatures, allow it to warm to room temperature before inserting batteries. Otherwise, you may damage the console displays or other electronic components.** Remove the screws, remove the battery cover, insert the batteries into the battery compartment, and then reattach the battery cover. **Make sure to orient the batteries as shown by the diagram inside the battery compartment.**

To purchase an optional AC adapter, contact the store where you purchased this product or call the telephone number on the cover of this manual. To avoid damaging the console, use only a manufacturer-supplied AC adapter. Plug one end of the AC adapter into the jack on the console; plug the other end into an outlet installed in accordance with all local codes and ordinances.

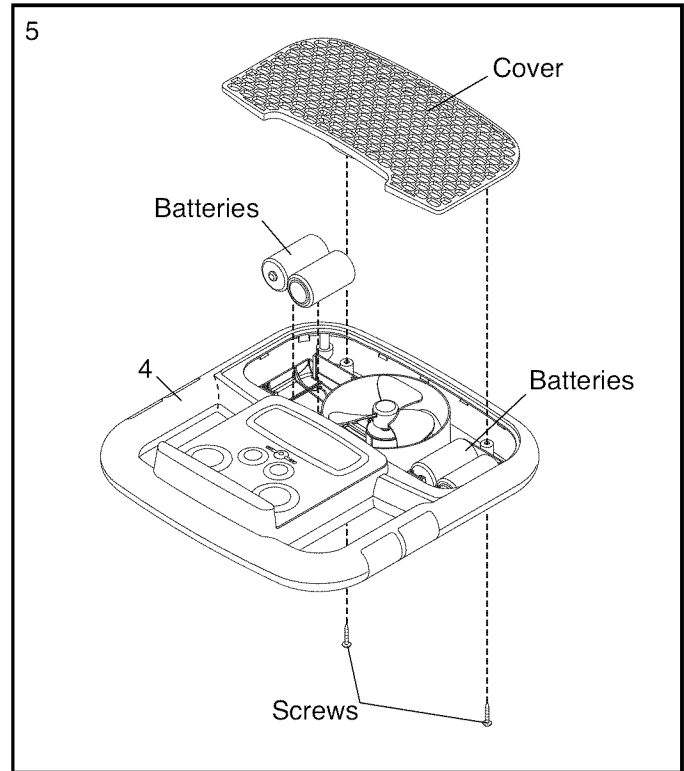

6. While a second person holds the Console (4) near the Upright (2), connect the console wire to the Wire Harness (100).

Tip: Do not pinch the wires. Attach the Console (4) with four M4 x 16mm Flat Head Screws (94).

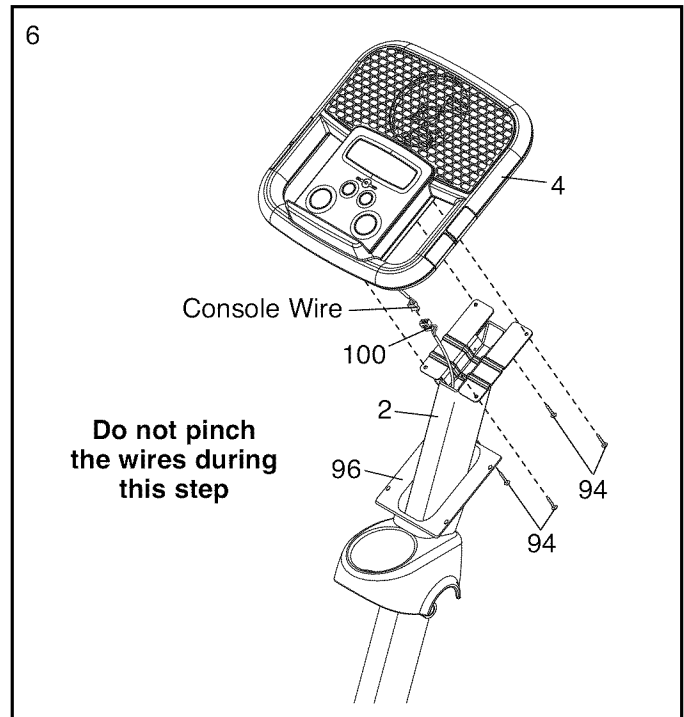

7. Slide the Console Cover (96) (**see the drawing in step 6**) upward to the Console (4). Attach the Console Cover with four M4 x 16mm Screws (84).

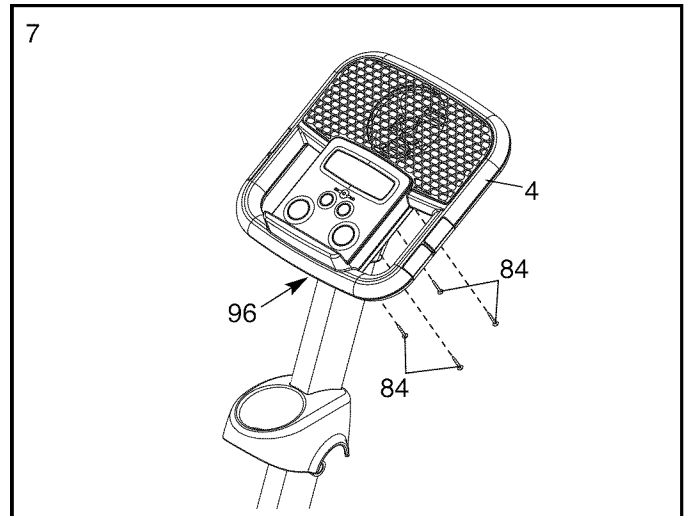

8. Apply a generous amount of the included grease to the Pivot Axle (16). Then, apply a small amount of grease to two Wave Washers (88).

Insert the Pivot Axle (16) into the Upright (2). Slide a Wave Washer (88) onto each end of the Pivot Axle.

Identify the Left Upper Body Leg (6), which is marked with a "Left" sticker. Slide the Left Upper Body Leg onto the Pivot Axle (16). Attach the Left Upper Body Leg with an M6 x 16mm Patch Screw (80) and a Large Axle Cover (20).

Attach the Right Upper Body Leg (31) in the same way.

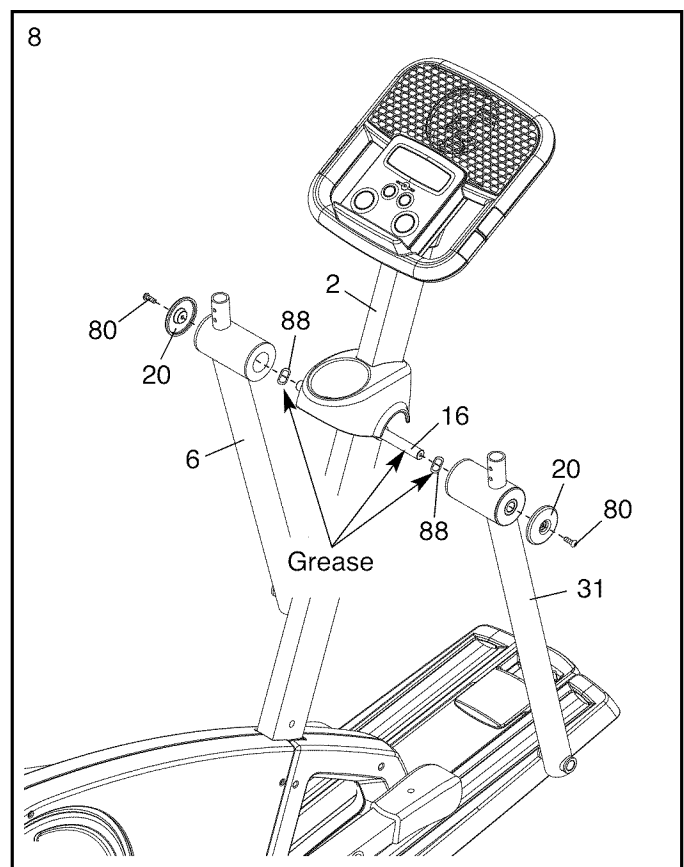

9. Attach the Left Pedal (12) to the left Pedal Arm (14) with three M10 x 70mm Patch Screws (75), three M10 Split Washers (78), and an M4 x 16mm Screw (84).

Repeat this step for the other side of the elliptical exerciser.

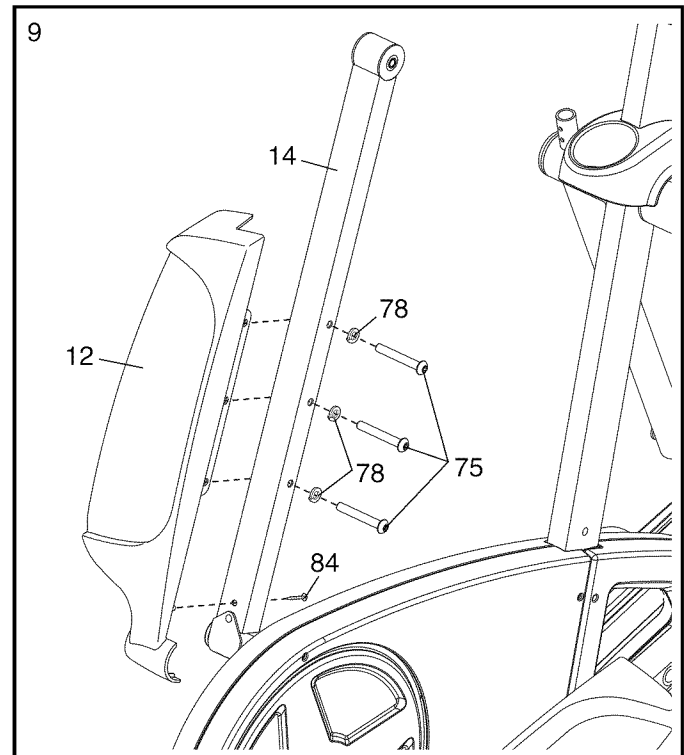

10. Apply a small amount of grease to two Wave Washers (88) and to the axles on a Pedal Arm Axle (21).

Identify an Upper Body Leg Spacer (113), which has a curved side. Slide a Wave Washer (88) and the Upper Body Leg Spacer onto the indicated axle of the Pedal Arm Axle (21); **make sure that the curved side of the Upper Body Leg Spacer is facing away from the Pedal Arm Axle.**

Identify a Pedal Leg Spacer (114), which has a flat side. Slide a Wave Washer (88) and the Pedal Leg Spacer onto the other axle of the Pedal Arm Axle (21); **make sure that the flat side of the Pedal Leg Spacer is facing away from the Pedal Arm Axle.**

Repeat this step for the other Pedal Arm Axle (not shown).

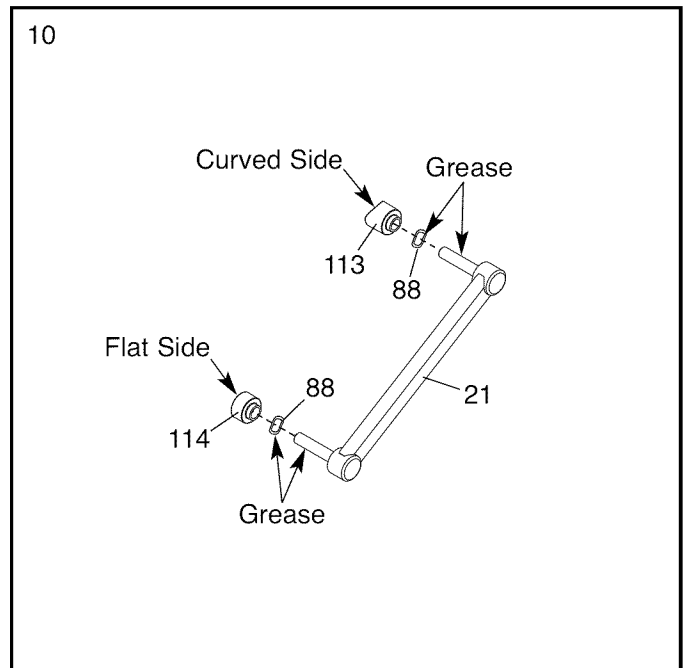

11. At the same time, insert a Pedal Arm Axle (21) into the Right Upper Body Leg (31) and into the right Pedal Arm (14); **make sure that the Upper Body Leg Spacer (113) and the Pedal Leg Spacer (114) are in the indicated locations.**

Attach the Right Upper Body Leg (31) with an M6 x 16mm Patch Screw (80) and an M6 Large Washer (90).

Then, attach the right Pedal Arm (14) with an M6 x 16mm Patch Screw (80) and an M6 Large Washer (90).

Repeat this step for the other side of the elliptical exerciser.

See step 3. Tighten the four M10 x 20mm Patch Screws (79). **Tip: Tighten the two Patch Screws on the front of the elliptical exerciser before tightening the other two Patch Screws.**

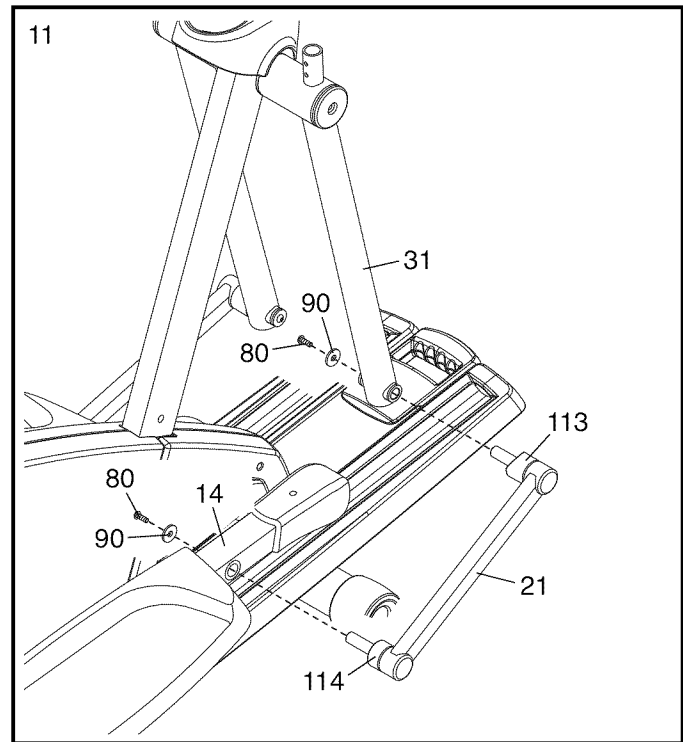

12. Identify the Right Upper Body Arm (9), which is marked with a “Right” sticker. Orient the Right Upper Body Arm as shown; **make sure that the hexagonal holes in the Right Upper Body Arm are in the indicated location.**

Slide the Right Upper Body Arm (9) onto the Right Upper Body Leg (31). Attach the Right Upper Body Arm with two M6 x 38mm Button Bolts (76) and two M6 Locknuts (77); **make sure that the Locknuts are inside the hexagonal holes.**

Repeat this step for the Left Upper Body Arm (8) and the Left Upper Body Leg (6).

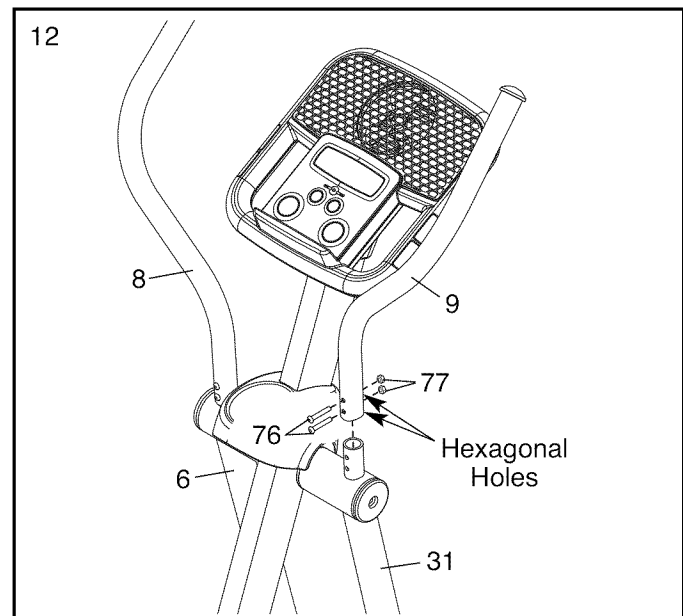

13. **Make sure that all parts of the elliptical exerciser are properly tightened.** Note: Some hardware may be left over after assembly is completed. To protect the floor or carpet from damage, place a mat under the elliptical exerciser.

HOW TO USE THE ELLIPTICAL EXERCISER

HOW TO MOVE THE ELLIPTICAL EXERCISER

Due to the size and weight of the elliptical exerciser, moving it requires two persons. Stand in front of the elliptical exerciser, hold the upright, and place one foot against one of the front wheels. **IMPORTANT: Do not place your foot on the ramp cover.** Pull on the upright and have a second person lift the base until the elliptical exerciser will roll on the front wheels. Carefully move the elliptical exerciser to the desired location, and then lower it to the floor.

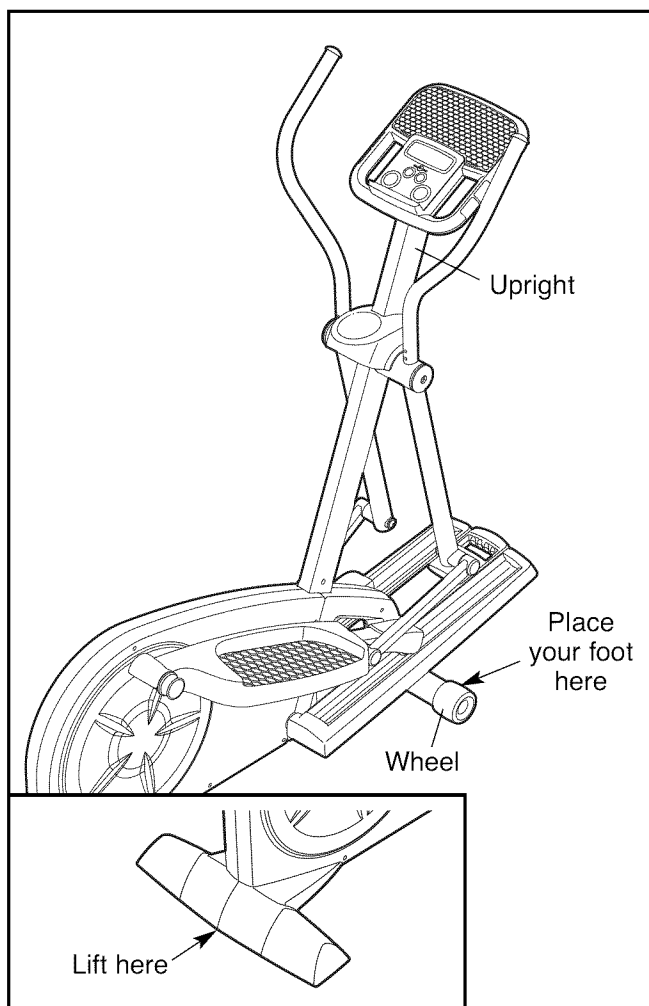

HOW TO EXERCISE ON THE ELLIPTICAL EXERCISER

To mount the elliptical exerciser, hold the upper body arms and step onto the pedal that is in the lowest position. Next, step onto the other pedal. Push the pedals until they begin to move with a continuous motion. **Note: The crank arms can turn in either direction. It is recommended that you turn the crank arms in the direction shown by the arrow below; however, for variety you can turn the crank arms in the opposite direction.**

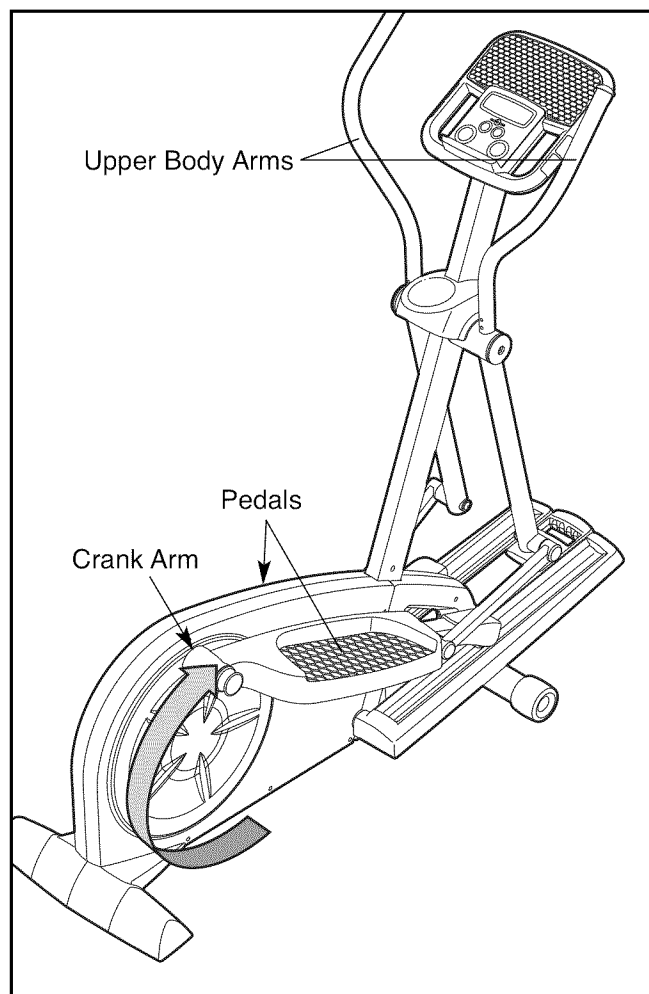

To dismount the elliptical exerciser, wait until the pedals come to a complete stop. **Note: The elliptical exerciser does not have a free wheel; the pedals will continue to move until the flywheel stops.** When the pedals are stationary, step off the higher pedal first. Then, step off the lower pedal.

HOW TO CHANGE THE INCLINE OF THE RAMP

To vary the motion of the pedals, you can change the incline of the ramp. To change the incline, pull the ramp handle outward, raise or lower the ramp, and engage the ramp pin into one of the adjustment holes in the front of the frame.

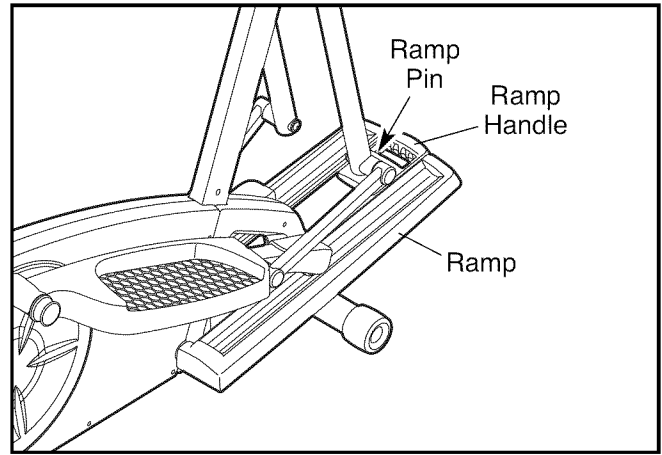

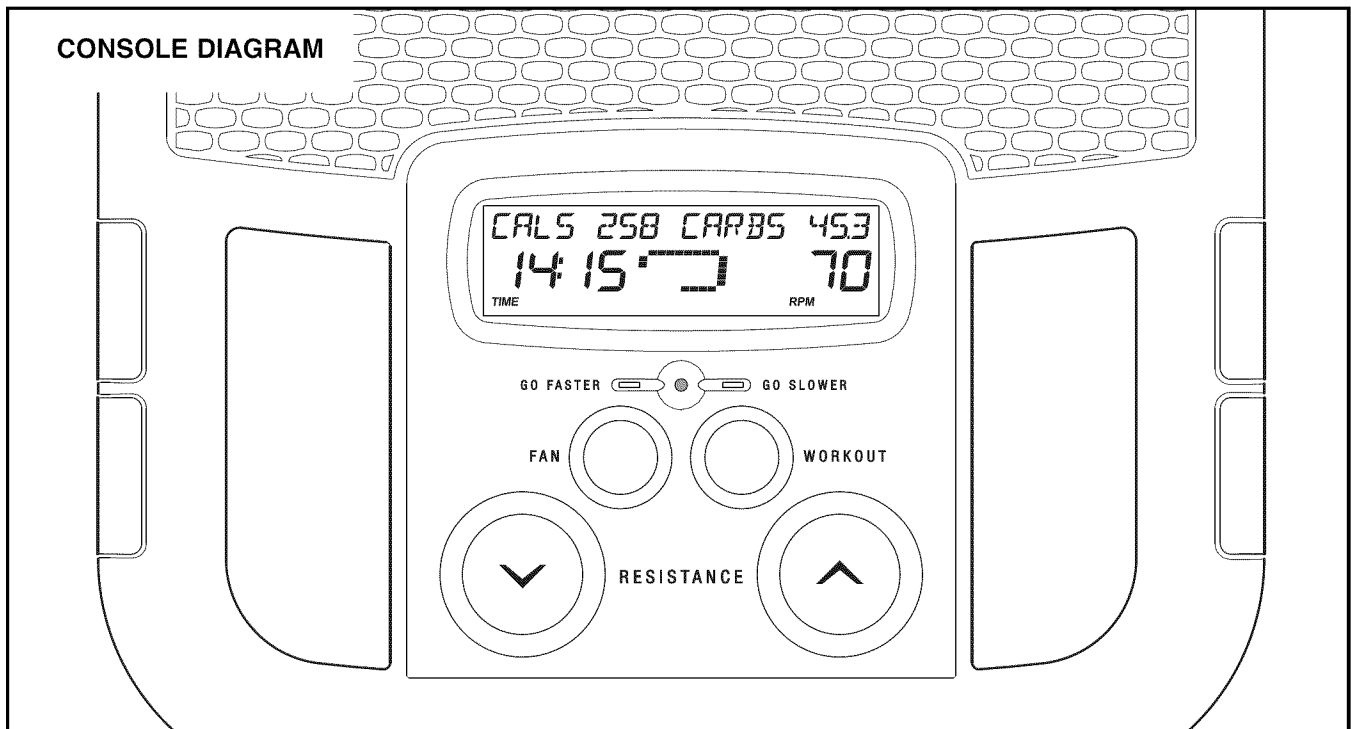

FEATURES OF THE CONSOLE

The advanced console offers an array of features designed to make your workouts more effective and enjoyable.

When you use the manual mode of the console, you can change the resistance of the pedals with the touch of a button. As you exercise, the console will display continuous exercise feedback. You can even measure your heart rate using the handgrip pulse sensor.

The console offers three interactive cross training workouts designed to help you to burn calories and enhance your cardiovascular system while toning and strengthening your muscles. The cross training workouts automatically control the resistance of the pedals and prompt you to perform a variety of strength exercises during your workout. Note: The strength exercises require the use of dumbbells and an inflatable exercise ball (not included). **To purchase dumbbells or an exercise ball, call 1-888-533-1333.**

The console also offers two target toning workouts designed to work specific areas of the body. The console guides you through each workout with a variety of exercise instructions while automatically changing the resistance of the pedals.

In addition, you can use three calorie goal workouts designed to help you burn 300 or 400 calories in 30- or 45-minute workouts. The calorie goal workouts automatically control the resistance of the pedals and prompt you to vary your pace while counting the calories you burn.

The console also has a high performance workout that automatically changes the resistance of the pedals and prompts you to vary your pace as it guides you through an effective workout.

To use the manual mode, see page 15. To use a cross training workout, see page 16. To use a target toning workout, see page 18. To use a calorie goal workout, see page 19. To use the high performance workout, see page 20.

HOW TO USE THE MANUAL MODE

Note: If there is a sheet of clear plastic on the face of the console, remove the plastic.

1. **Press the Resistance decrease button or begin pedaling to turn on the console.**

A moment after you turn on the console, the displays will light.

2. **Select the manual mode.**

Each time you turn on the console, the manual mode will be selected automatically. If you have selected a workout, reselect the manual mode by pressing the Workout button repeatedly until the words MANUAL MODE appear in the upper display.

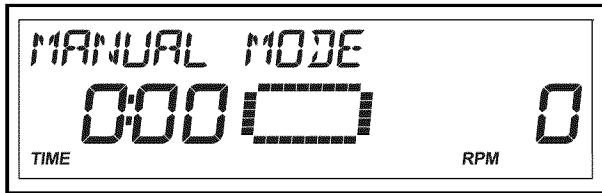

3. **Begin pedaling and change the resistance of the pedals as desired.**

As you pedal, change the resistance of the pedals by pressing the Resistance increase and decrease buttons repeatedly. There are ten resistance levels. Note: After you press the buttons, it will take a moment for the pedals to reach the selected resistance level.

4. **Follow your progress with the displays.**

The left display—This display will show the elapsed time. Note: When you select a workout, the display will show the time remaining in the workout instead of the elapsed time.



The left display will also show your heart rate when you use the handgrip pulse sensor (see step 5 on page 16).

When you select a workout, the left display will also show the approximate number of calories you have burned.

The center display—

When you select the manual mode, the center display will show a track that represents 640 revolutions. As you exercise, indicators will appear in succession around the track until the entire track appears. The track will then disappear and the indicators will again begin to appear in succession.

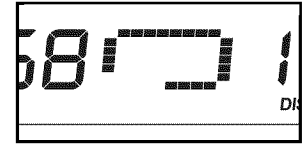

The center display will also show the resistance level of the pedals for a few seconds each time the resistance level changes.

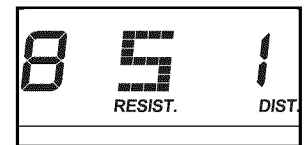

The right display—

This display will show the distance (total revolutions) you have pedaled and your pedaling pace, in revolutions per minute (rpm).

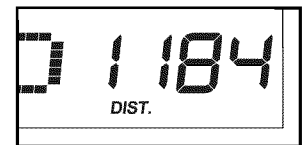

The upper display—When you select the manual mode, the upper display will show the approximate number of calories you have burned and the approximate number of grams of carbs you have burned.

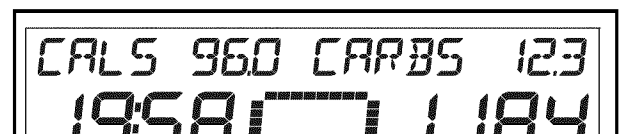

5. Measure your heart rate if desired.

If there are sheets of clear plastic on the metal contacts on the handgrip pulse sensor, remove the plastic. To measure your heart rate, hold the handgrip pulse sensor with your palms resting against the metal contacts. **Avoid moving your hands or gripping the contacts tightly.**

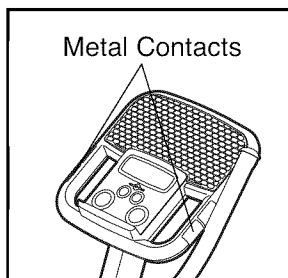

When your pulse is detected, a heart-shaped symbol will flash in the left display. Each time your heart beats, one or two



dashes will appear, and then your heart rate will be shown. For the most accurate heart rate reading, hold the contacts for at least 15 seconds. Note: If you continue to hold the handgrip pulse sensor, the display will show your heart rate for up to 30 seconds.

If your heart rate is not shown, make sure that your hands are positioned as described. Be careful not to move your hands excessively or to squeeze the metal contacts tightly. For optimal performance, clean the metal contacts using a soft cloth; **never use alcohol, abrasives, or chemicals to clean the contacts.**

6. Turn on the fan if desired.

The fan has high and low speed settings. Press the Fan button repeatedly to select a fan speed or to turn off the fan. Note: If the pedals do not move for about thirty seconds, the fan will turn off automatically.

7. When you are finished exercising, the console will turn off automatically.

If the pedals do not move for several seconds, a series of tones will sound, the console will pause, and the time will flash in the display.

If the pedals do not move for about five minutes, the console will turn off and the display will be reset.

HOW TO USE A CROSS TRAINING WORKOUT

1. Turn on the console.

See step 1 on page 15.

2. Select a cross training workout.

To select a cross training workout, press the Workout button repeatedly until the words UPPER BODY, LOWER BODY, or WHOLE BODY appear in the upper display.

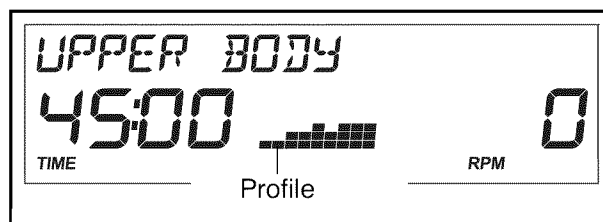

When you select a cross training workout, the name of the workout and the workout time will appear in the displays and a profile of the resistance levels of the workout will scroll across the center display.

3. Begin pedaling to start the workout.

Each workout is divided into 25 or 45 one-minute segments. One resistance level and one target rpm (revolutions per minute) setting are programmed for most segments. (Note: The same resistance level and/or target rpm setting may be programmed for consecutive segments.) During other segments, the console will prompt you to perform strength exercises.

During the workout, the workout profile will show your progress (see the drawing above). The flashing segment of the profile represents the current segment of the workout. The height of the flashing segment indicates the resistance level for the current segment. At the end of each segment of the workout, a series of tones will sound and the next segment of the profile will begin to flash. If a different resistance level is programmed for the next segment, the resistance level will appear in the display for a few seconds to alert you. The resistance of the pedals will then change.

As you exercise, you will be prompted to keep your pedaling pace near the target rpm setting for the current segment. When the words PEDAL FASTER appear in the upper display or the GO FASTER indicator on the pace guide is lit, increase your pace. When the words PEDAL SLOWER appear or the GO SLOWER indicator is lit, decrease your pace. When the words PEDALING IN RANGE appear or when the center indicator is lit, maintain your current pace.

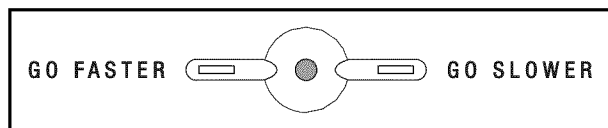

IMPORTANT: The target rpm settings are intended only to provide motivation. Your actual pace may be slower than the target rpm settings. Make sure to pedal at a pace that is comfortable for you.

If the resistance level for the current segment is too high or too low, you can manually override the setting by pressing the Resistance decrease and increase buttons. However, when the current segment ends, the pedals will automatically adjust to the resistance level for the next segment.

If you stop pedaling for several seconds, a series of tones will sound and the workout will pause. To restart the workout, simply resume pedaling. The workout will continue until the last segment of the profile flashes and the last segment of the workout ends.

4. Perform the first strength exercise when prompted.

When the first strength exercise segment begins, the name of the first strength exercise will appear in the upper display for a few seconds. The time will pause and flash in the left display.

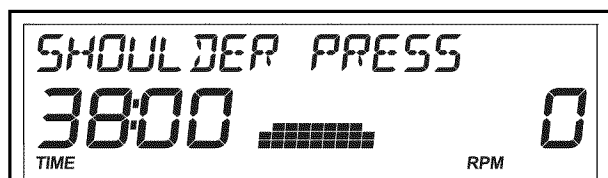

Next, the upper display will show the recommended number of repetitions for the first strength exercise.

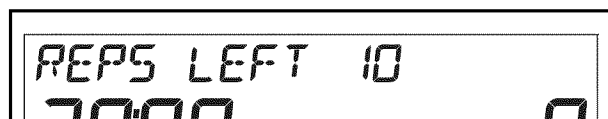

Step off the elliptical exerciser and prepare to begin the first strength exercise. Every few seconds, the console will sound a tone; when a tone sounds, perform one repetition of the exercise. Exercise with a slow, steady motion; do not perform more than one repetition each time a tone sounds. The display will count down the repetitions as you perform them.

Note: Refer to a weight training manual or exercise guide if you are unfamiliar with the correct form for each strength exercise. When performing lunges, alternate legs with each repetition. When performing dumbbell rows, perform half the repetitions with your right arm and half the repetitions with your left arm. The strength exercises require the use of dumbbells and an inflatable exercise ball (not included). **To purchase dumbbells or an exercise ball, call 1-888-533-1333.**

5. Continue the cross training workout.

When you have performed the recommended number of repetitions, the words START PEDALING will appear in the upper display. To continue the cross training workout, step onto the elliptical exerciser and start pedaling. The pedals will automatically adjust to the resistance level for the next segment.

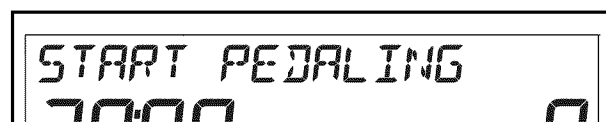

The workout will continue in this way until the last segment ends. Then, the words PROGRAM DONE will appear in the upper display.

6. Follow your progress with the displays.

See step 4 on page 15.

7. Measure your heart rate if desired.

See step 5 on page 16.

8. Turn on the fan if desired.

See step 6 on page 16.

9. When you are finished exercising, the console will turn off automatically.

See step 7 on page 16.

HOW TO USE A TARGET TONING WORKOUT

1. Turn on the console.

See step 1 on page 15.

2. Select a target toning workout.

To select a target toning workout, press the Workout button repeatedly until the words TARGET TONING 1 or TARGET TONING 2 appear in the upper display.

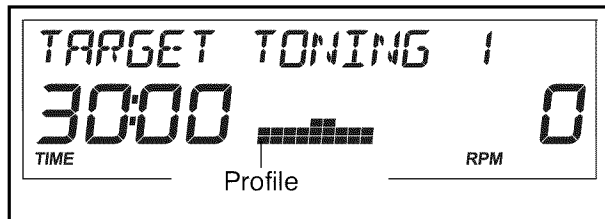

When you select a target toning workout, the name of the workout and the workout time will appear in the displays and a profile of the resistance levels of the workout will scroll across the center display.

3. Begin pedaling to start the workout.

Each workout is divided into 30 one-minute segments. One resistance level and one target rpm (revolutions per minute) setting are programmed for each segment. Note: The same resistance level and/or target rpm setting may be programmed for consecutive segments.

During the workout, the workout profile will show your progress (see the drawing above). The flashing segment of the profile represents the current segment of the workout. The height of the flashing segment indicates the resistance level for the current segment. At the end of each segment of the workout, a series of tones will sound and the next segment of the profile will begin to flash. If a different resistance level is programmed for the next segment, the resistance level will appear in the display for a few seconds to alert you. The resistance of the pedals will then change.

As you exercise, the console will display a variety of exercise instructions that will help you get the most benefit from your workout. For example, the console may instruct you to PEDAL BACKWARD, USE UPPER BODY, or FOCUS LOWER BODY during certain segments of the workout.

As you exercise, you will be prompted to keep your pedaling pace near the target rpm setting for the current segment. When the words PEDAL FASTER appear in the upper display or the GO FASTER indicator on the pace guide is lit, increase your pace. When the words PEDAL SLOWER appear or the GO SLOWER indicator is lit, decrease your pace. When the words PEDALING IN RANGE appear or when the center indicator is lit, maintain your current pace.

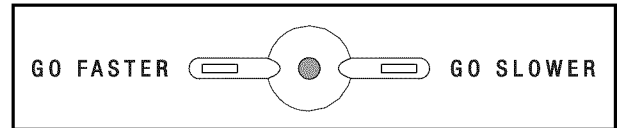

IMPORTANT: The target rpm settings are intended only to provide motivation. Your actual pace may be slower than the target rpm settings. Make sure to pedal at a pace that is comfortable for you.

If the resistance level for the current segment is too high or too low, you can manually override the setting by pressing the Resistance decrease and increase buttons. However, when the current segment ends, the pedals will automatically adjust to the resistance level for the next segment.

If you stop pedaling for several seconds, a series of tones will sound and the workout will pause. To restart the workout, simply resume pedaling. The workout will continue until the last segment of the profile flashes and the last segment of the workout ends.

When the last segment of the workout ends, the words PROGRAM DONE will appear in the upper display.

4. Follow your progress with the displays.

See step 4 on page 15.

5. Measure your heart rate if desired.

See step 5 on page 16.

6. Turn on the fan if desired.

See step 6 on page 16.

7. When you are finished exercising, the console will turn off automatically.

See step 7 on page 16.

HOW TO USE A CALORIE GOAL WORKOUT

1. Turn on the console.

See step 1 on page 15.

2. Select a calorie goal workout.

Press the Workout button repeatedly until the name of the desired calorie goal workout appears in the upper display. When you select a calorie goal workout, the name of the workout and the workout time will appear in the displays and a profile of the resistance levels of the workout will scroll across the center display.

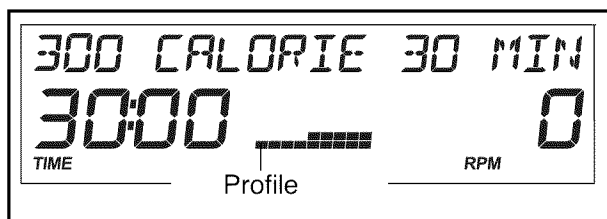

3. Begin pedaling to start the workout.

Each workout is divided into 30 or 45 one-minute segments. One resistance level and one target rpm (revolutions per minute) setting are programmed for each segment. Note: The same resistance level and/or target rpm setting may be programmed for consecutive segments. The displays for a calorie goal workout will work in the same way as the displays for a cross training workout (see step 3 on page 16).

As you exercise, you will be prompted to keep your pedaling pace near the target rpm setting for the current segment. When the words PEDAL FASTER appear in the upper display or the GO FASTER indicator on the pace guide is lit, increase your pace. When the words PEDAL SLOWER appear or the GO SLOWER indicator is lit, decrease your pace. When the words PEDALING IN RANGE appear or when the center indicator is lit, maintain your current pace.

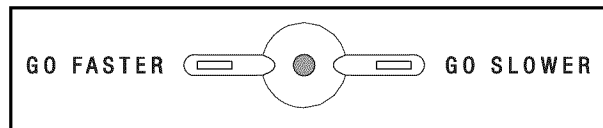

IMPORTANT: The target rpm settings are intended only to provide motivation. Your actual pace may be slower than the target rpm settings. Make sure to pedal at a pace that is comfortable for you. Note: If you manually override the resistance settings of a calorie goal workout, you may not reach your calorie goal.

If you stop pedaling for several seconds, a series of tones will sound and the workout will pause. To restart the workout, simply resume pedaling. The workout will continue until the last segment of the profile flashes and the last segment of the workout ends.

When the last segment of the workout ends, the words PROGRAM DONE will appear in the upper display.

4. Follow your progress with the displays.

See step 4 on page 15.

5. Measure your heart rate if desired.

See step 5 on page 16.

6. Turn on the fan if desired.

See step 6 on page 16.

7. When you are finished exercising, the console will turn off automatically.

See step 7 on page 16.

HOW TO USE THE HIGH PERFORMANCE WORKOUT

1. Turn on the console.

See step 1 on page 15.

2. Select the high performance workout.

Press the Workout button repeatedly until the words HIGH PERFORMANCE appear in the upper display. The workout time will appear in the left display and a profile of the resistance levels for the workout will scroll across the center display.

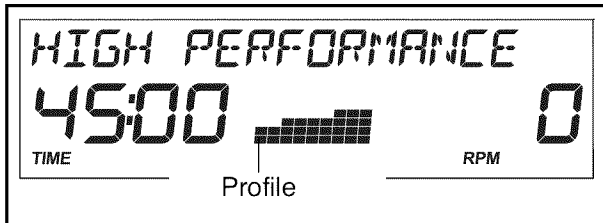

3. Begin pedaling to start the workout.

The workout is divided into 45 one-minute segments. One resistance level and one target rpm setting are programmed for each segment. Note: The same resistance level and/or target rpm (revolutions per minute) setting may be programmed for consecutive segments. The displays for the high performance workout will work in the same way as the displays for a cross training workout (see step 3 on page 16).

As you exercise, you will be prompted to keep your pedaling pace near the target rpm setting for the current segment. When the words PEDAL FASTER appear in the upper display or the GO FASTER indicator on the pace guide is lit, increase your pace. When the words PEDAL SLOWER appear or the GO SLOWER indicator is lit, decrease your pace. When the words PEDALING IN RANGE appear or when the center indicator is lit, maintain your current pace.

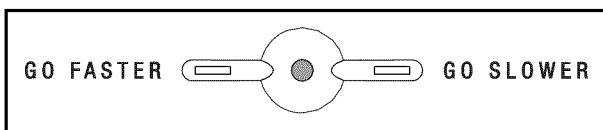

IMPORTANT: The target rpm settings are intended only to provide motivation. Your actual pace may be slower than the target rpm settings. Make sure to pedal at a pace that is comfortable for you.

If you stop pedaling for several seconds, a series of tones will sound and the workout will pause. To restart the workout, simply resume pedaling. The workout will continue until the last segment of the profile flashes and the last segment of the workout ends.

When the last segment of the workout ends, the words PROGRAM DONE will appear in the upper display.

4. Follow your progress with the displays.

See step 4 on page 15.

5. Measure your heart rate if desired.

See step 5 on page 16.

6. Turn on the fan if desired.

See step 6 on page 16.

7. When you are finished exercising, the console will turn off automatically.

See step 7 on page 16.

MAINTENANCE AND TROUBLESHOOTING

Inspect and tighten all parts of the elliptical exerciser regularly. Replace any worn parts immediately.

To clean the elliptical exerciser, use a damp cloth and a small amount of mild soap. **IMPORTANT: To avoid damage to the console, keep liquids away from the console and keep the console out of direct sunlight.**

CONSOLE TROUBLESHOOTING

If the console displays become dim, the batteries should be replaced; most console problems are the result of low batteries. See assembly step 5 on page 8 for replacement instructions. If the handgrip pulse sensor does not function properly, see step 5 on page 16.

HOW TO ADJUST THE REED SWITCH

If the console does not display correct feedback, the reed switch should be adjusted. First, remove all of the screws from both shields; **there are three sizes of screws in the shields—note which size of screw you remove from each hole.** Then, gently pry the shields away from the frame.

Next, locate the Reed Switch (58). Turn the Left Pedal Disc (26) until the Magnet (41) is aligned with the Reed Switch. Loosen, but do not remove, the indicated M4 x 16mm Screw (84).

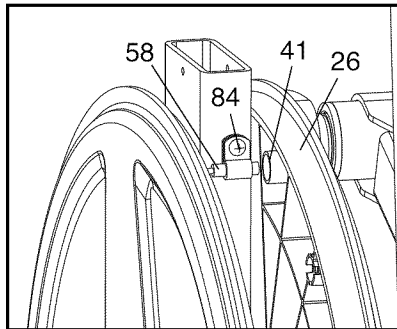

(84). Slide the Reed Switch slightly closer to or away from the Magnet, and then retighten the Screw. Rock the Left Pedal Disc forward and backward just enough that the Magnet passes the Reed Switch repeatedly. Repeat until the console displays correct feedback. When the Reed Switch is correctly adjusted, reattach the shields. Note: If you have questions as to which screw should be in which hole, see EXPLODED DRAWING B on page 27 and the PART LIST on page 24.

HOW TO ADJUST THE BELT

If you can feel the pedals slip while you are pedaling, even when the resistance of the pedals is at the highest setting, the Belt (46) may need to be adjusted. First, remove all the screws from both shields; **there are three sizes of screws in the shields—note which size of screw you remove from each hole.** Then, gently pry the shields away from the frame.

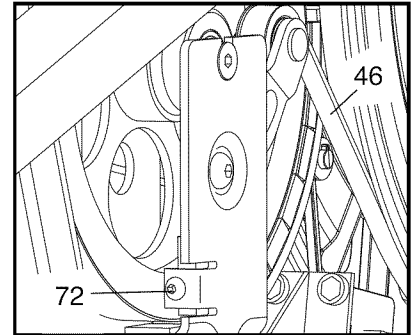

Next, turn the Belt Adjustment Screw (72) until the Belt (46) is tight. Then, reattach the shields. Note: If you have questions as to which screw should be in which hole, see EXPLODED DRAWING B on page 27 and the PART LIST on page 24.

EXERCISE GUIDELINES

⚠ WARNING: Before beginning this or any exercise program, consult your physician. This is especially important for persons over the age of 35 or persons with pre-existing health problems.

The pulse sensor is not a medical device. Various factors may affect the accuracy of heart rate readings. The pulse sensor is intended only as an exercise aid in determining heart rate trends in general.

These guidelines will help you to plan your exercise program. For detailed exercise information, obtain a reputable book or consult your physician. Remember, proper nutrition and adequate rest are essential for successful results.

EXERCISE INTENSITY

Whether your goal is to burn fat or to strengthen your cardiovascular system, exercising at the proper intensity is the key to achieving results. You can use your heart rate as a guide to find the proper intensity level. The chart below shows recommended heart rates for fat burning and aerobic exercise.

165	155	145	140	130	125	115	♥
145	138	130	125	118	110	103	♥
125	120	115	110	105	95	90	♥
<hr/>							
20	30	40	50	60	70	80	

To find the proper intensity level, find your age at the bottom of the chart (ages are rounded off to the nearest ten years). The three numbers listed above your age define your “training zone.” The lowest number is the heart rate for fat burning, the middle number is the heart rate for maximum fat burning, and the highest number is the heart rate for aerobic exercise.

Burning Fat—To burn fat effectively, you must exercise at a low intensity level for a sustained period of time. During the first few minutes of exercise, your body uses *carbohydrate calories* for energy. Only after the first few minutes of exercise does your body begin to use stored *fat calories* for energy. If your goal is to burn fat, adjust the intensity of your exercise until your heart rate is near the lowest number in your training zone. For maximum fat burning, exercise with your heart rate near the middle number in your training zone.

Aerobic Exercise—If your goal is to strengthen your cardiovascular system, you must perform aerobic exercise, which is activity that requires large amounts of oxygen for prolonged periods of time. For aerobic exercise, adjust the intensity of your exercise until your heart rate is near the highest number in your training zone.

WORKOUT GUIDELINES

Warming Up—Start with 5 to 10 minutes of stretching and light exercise. A warm-up increases your body temperature, heart rate, and circulation in preparation for exercise.

Training Zone Exercise—Exercise for 20 to 30 minutes with your heart rate in your training zone. (During the first few weeks of your exercise program, do not keep your heart rate in your training zone for longer than 20 minutes.) Breathe regularly and deeply as you exercise—never hold your breath.

Cooling Down—Finish with 5 to 10 minutes of stretching. Stretching increases the flexibility of your muscles and helps to prevent post-exercise problems.

EXERCISE FREQUENCY

To maintain or improve your condition, complete three workouts each week, with at least one day of rest between workouts. After a few months of regular exercise, you may complete up to five workouts each week, if desired. Remember, the key to success is to make exercise a regular and enjoyable part of your everyday life.

SUGGESTED STRETCHES

The correct form for several basic stretches is shown at the right. Move slowly as you stretch—never bounce.

1. Toe Touch Stretch

Stand with your knees bent slightly and slowly bend forward from your hips. Allow your back and shoulders to relax as you reach down toward your toes as far as possible. Hold for 15 counts, then relax. Repeat 3 times. Stretches: Hamstrings, back of knees, and back.

2. Hamstring Stretch

Sit with one leg extended. Bring the sole of the opposite foot toward you and rest it against the inner thigh of your extended leg. Reach toward your toes as far as possible. Hold for 15 counts, then relax. Repeat 3 times for each leg. Stretches: Hamstrings, lower back, and groin.

3. Calf/Achilles Stretch

With one leg in front of the other, reach forward and place your hands against a wall. Keep your back leg straight and your back foot flat on the floor. Bend your front leg, lean forward and move your hips toward the wall. Hold for 15 counts, then relax. Repeat 3 times for each leg. To cause further stretching of the achilles tendons, bend your back leg as well. Stretches: Calves, achilles tendons, and ankles.

4. Quadriceps Stretch

With one hand against a wall for balance, reach back and grasp one foot with your other hand. Bring your heel as close to your buttocks as possible. Hold for 15 counts, then relax. Repeat 3 times for each leg. Stretches: Quadriceps and hip muscles.

5. Inner Thigh Stretch

Sit with the soles of your feet together and your knees outward. Pull your feet toward your groin area as far as possible. Hold for 15 counts, then relax. Repeat 3 times. Stretches: Quadriceps and hip muscles.

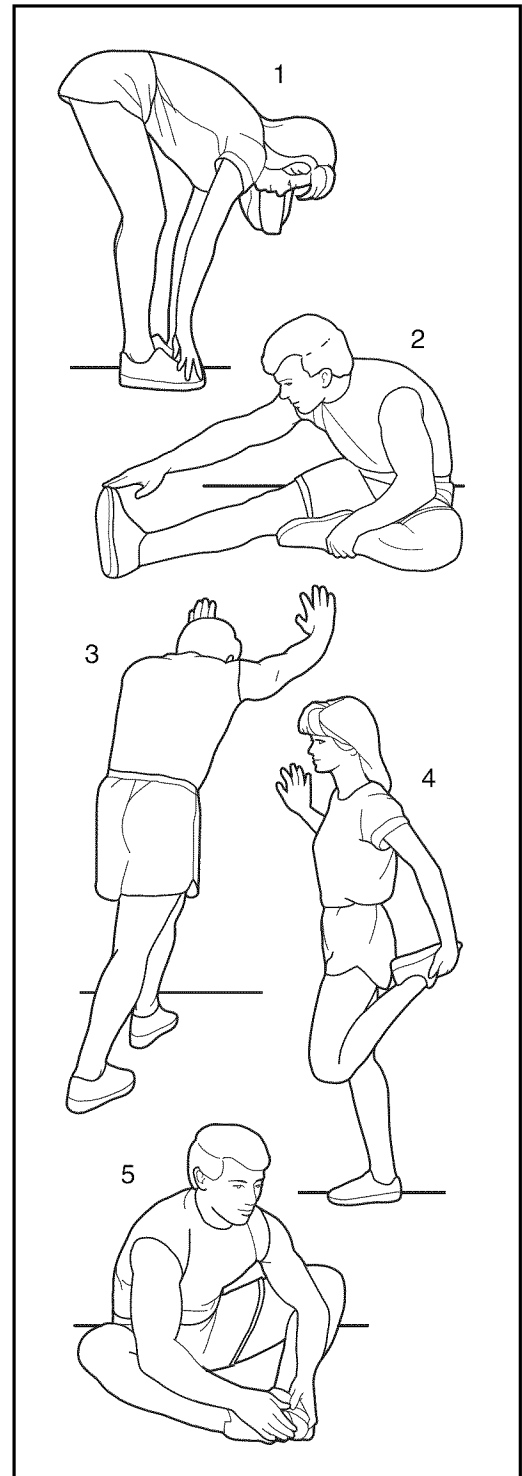

PART LIST—Model No. 831.23844.0

R0708B

Key No.	Qty.	Description	Key No.	Qty.	Description
1	1	Frame	51	1	Flywheel
2	1	Upright	52	1	Idler
3	1	Console Bracket	53	1	C-magnet
4	1	Console	54	1	Resistance Motor
5	1	Water Bottle Holder	55	1	Motor Bracket
6	1	Left Upper Body Leg	56	1	Resistance Arm
7	1	Idler Wheel	57	1	Clamp
8	1	Left Upper Body Arm	58	1	Reed Switch/Wire
9	1	Right Upper Body Arm	59	1	Magnet Spacer
10	2	Foam Grip	60	1	Key
11	2	Upper Cap	61	1	Square Nut
12	1	Left Pedal	62	1	Button Screw
13	1	Right Pedal	63	2	M10 x 41mm Shoulder Patch Screw
14	2	Pedal Arm	64	1	Flywheel Bolt
15	2	Pedal Bracket	65	1	C-magnet Bolt
16	1	Pivot Axle	66	1	Idler Bolt
17	2	Inner Bushing Set	67	1	Key Screw
18	2	Outer Bushing Set	68	1	Crank Arm Screw
19	10	Upright Bushing	69	4	Resistance Motor Bolt
20	2	Large Axle Cover	70	4	Resistance Motor Nut
21	2	Pedal Arm Axle	71	5	Motor Bracket Screw
22	4	Axle Cover	72	1	Belt Adjustment Screw
23	2	Roller Cover	73	2	M8 x 58mm Shoulder Bolt
24	1	Crank Assembly	74	4	M8 Locknut
25	1	Crank Arm	75	6	M10 x 70mm Patch Screw
26	1	Left Pedal Disc	76	4	M6 x 38mm Button Bolt
27	1	Right Pedal Disc	77	4	M6 Locknut
28	1	Pedal Disc Cover	78	10	M10 Split Washer
29	4	Bracket Bearing	79	4	M10 x 20mm Patch Screw
30	1	Tree Fastener	80	6	M6 x 16mm Patch Screw
31	1	Right Upper Body Leg	81	4	M8 x 12mm Button Screw
32	2	M8 x 18mm Hex Screw	82	1	M10 Locknut
33	2	M10 Washer	83	9	M6 Star Washer
34	1	M4 x 13mm Screw	84	39	M4 x 16mm Screw
35	2	Pedal Arm Bracket	85	2	Flywheel Spacer
36	2	Bracket Cover	86	4	M8 Washer
37	2	M10 x 16mm Button Screw	87	2	M5 x 30mm Screw
38	2	Crank Bearing	88	6	Wave Washer
39	1	Crank Spacer	89	12	M4 Washer
40	1	Crank Arm Spacer	90	10	M6 Large Washer
41	2	Magnet	91	3	M4 x 48mm Screw
42	1	Left Front Shield	92	16	M4 x 25mm Screw
43	1	Right Front Shield	93	2	M4 x 35mm Screw
44	1	Left Shield	94	4	M4 x 16mm Flat Head Screw
45	1	Right Shield	95	2	M4 x 32mm Screw
46	1	Belt	96	1	Console Cover
47	2	Foot	97	4	Roller Bushing
48	1	Left Frame Cover	98	9	M5 x 12mm Screw
49	1	Right Frame Cover	99	1	M3.5 x 12mm Screw
50	2	Wheel			

Key No.	Qty.	Description	Key No.	Qty.	Description
100	1	Wire Harness	110	1	Ramp Lock Bushing
101	1	Extended Reed Switch Wire	111	6	Ramp Bushing
102	2	M8 x 50mm Bolt Set	112	1	Ramp Axle
103	1	Ramp Cover	113	2	Upper Body Leg Spacer
104	1	Ramp	114	2	Pedal Leg Spacer
105	1	Top Ramp Handle	115	2	Roller
106	1	Bottom Ramp Handle	*	–	User's Manual
107	1	Ramp Lock Shaft	*	–	Hex Key
108	1	Ramp Lock Spring	*	–	Grease Packet
109	1	Ramp Lock Pin			

Note: Specifications are subject to change without notice. See the back cover of this manual for information about ordering replacement parts. *These parts are not illustrated. **If a part is missing, call 1-888-533-1333.**

EXPLODED DRAWING A—Model No. 831.23844.0

R0708B

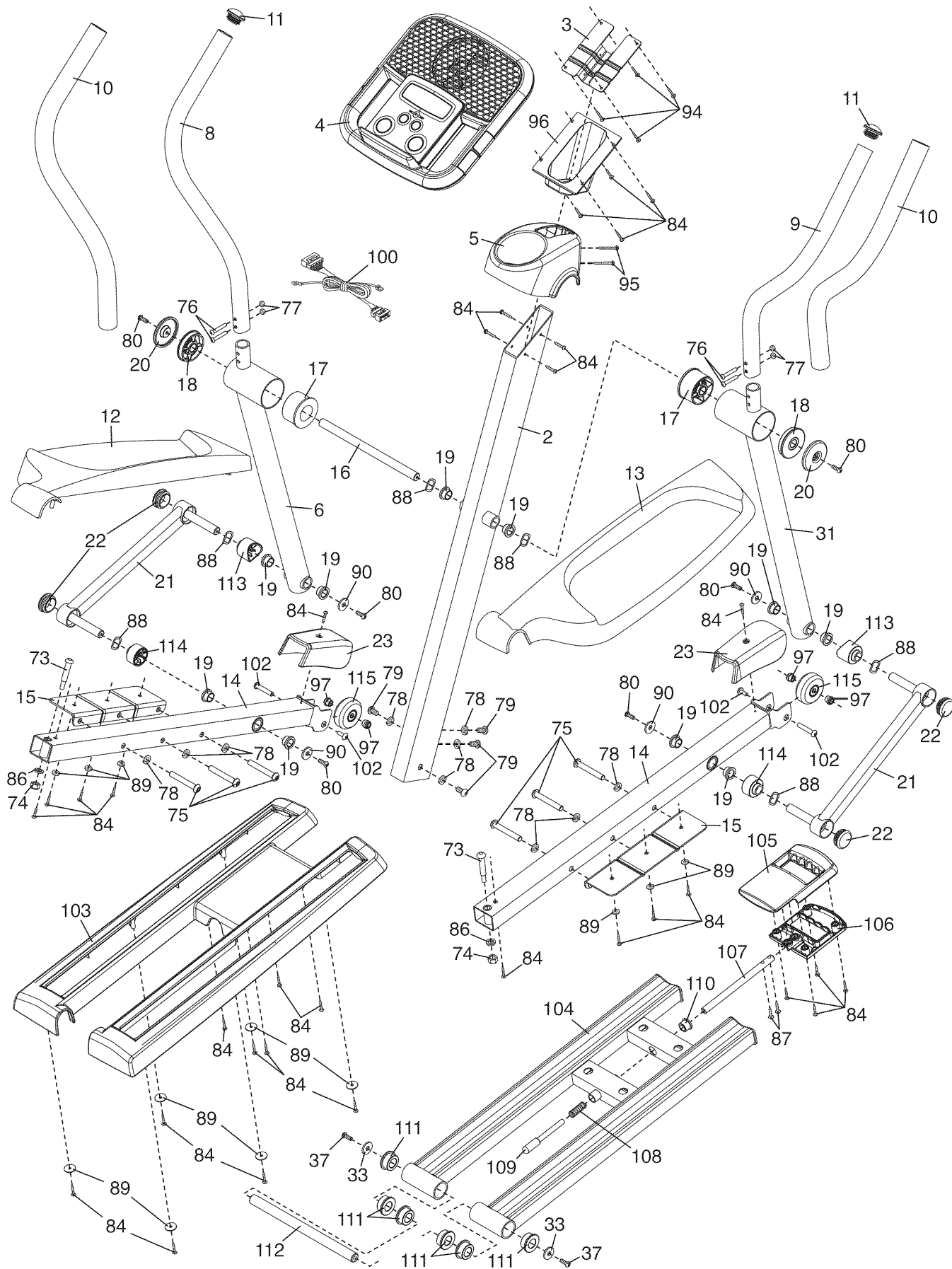

EXPLODED DRAWING B—Model No. 831.23844.0

R0708B

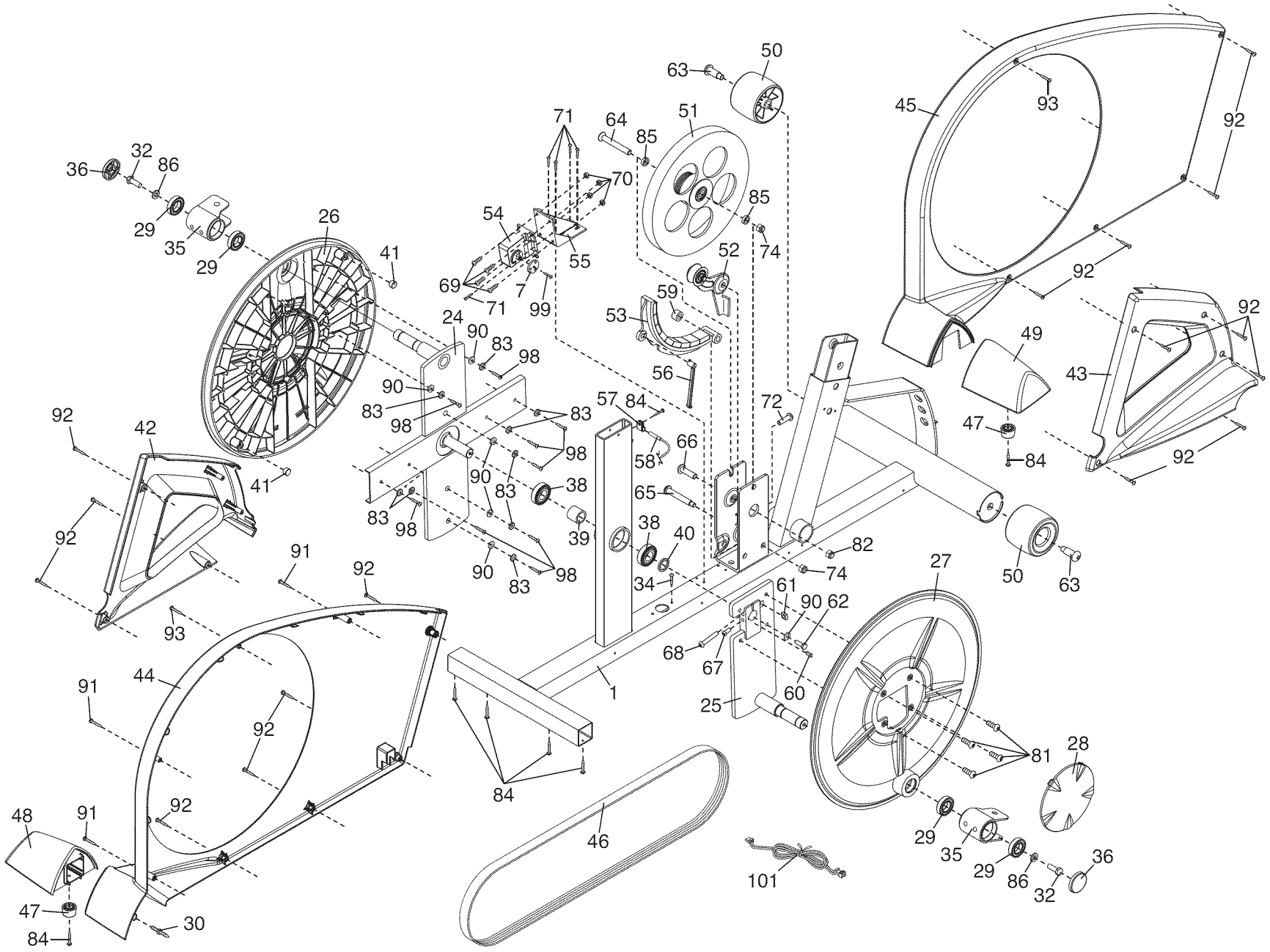

27

Get it fixed, at your home or ours!

Your Home

For repair—**in your home**—of **all** major brand appliances, lawn and garden equipment, or heating and cooling systems, **no matter who made it, no matter who sold it!**

For the replacement parts, accessories, and user's manuals that you need to do-it-yourself.

For Sears professional installation of home appliances and items like garage door openers and water heaters.

1-800-4-MY-HOME® (1-800-469-4663)

Call anytime, day or night (U.S.A. and Canada)

www.sears.com

www.sears.ca

Our Home

For repair of carry-in items like vacuums, lawn equipment, and electronics, call or go on-line for the location of your nearest **Sears Parts & Repair Center.**

1-800-488-1222 Call anytime, day or night (U.S.A. only)

www.sears.com

To purchase a protection agreement (U.S.A.) or maintenance agreement (Canada) on a product serviced by Sears:

1-800-827-6655 (U.S.A.)

1-800-361-6665 (Canada)

Para pedir servicio de reparación a domicilio, y para ordenar piezas:

1-888-SU-HOGAR® (1-888-784-6427)



® Registered Trademark / ™ Trademark / ™ Service Mark of Sears Brands, LLC
® Marca Registrada / ™ Marca de Fábrica / ™ Marca de Servicio de Sears Brands, LLC

90 DAY FULL WARRANTY

If this Sears Elliptical Exerciser fails due to a defect in material or workmanship within 90 days of the date of purchase, call 1-800-4-MY-HOME® (1-800-469-4663) to arrange for free repair (or replacement if repair proves impossible). The frame is warranted for 7 years from the date of purchase.

This warranty does not apply when the Elliptical Exerciser is used commercially or for rental purposes.

This warranty gives you specific legal rights, and you may also have other rights which vary from state to state.

Sears, Roebuck and Co., Hoffman Estates, IL 60179