

# PRO-FORM<sup>®</sup> CROSS WALK<sup>™</sup> plus

Model No. DRTL00740/PFTL00740

Serial No. \_\_\_\_\_

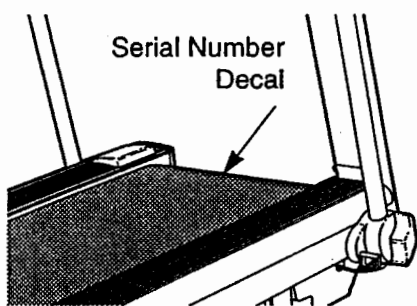

## QUESTIONS?

As a manufacturer, we are committed to providing you complete customer satisfaction. If you have questions, or find there are missing or damaged parts, we will guarantee you complete satisfaction through direct assistance from our factory. TO AVOID UNNECESSARY DELAYS, PLEASE CALL DIRECT TO OUR TOLL-FREE CUSTOMER HOT LINE. The trained technicians on our Customer Hot Line will provide immediate assistance, free of charge to you.

**CUSTOMER HOT LINE:**  
**1-800-999-3756**  
Mon.-Fri., 6 a.m.-6 p.m. MST

## **▲ CAUTION:**

Read all precautions and instructions in this manual before using this equipment. Save this manual for future reference.

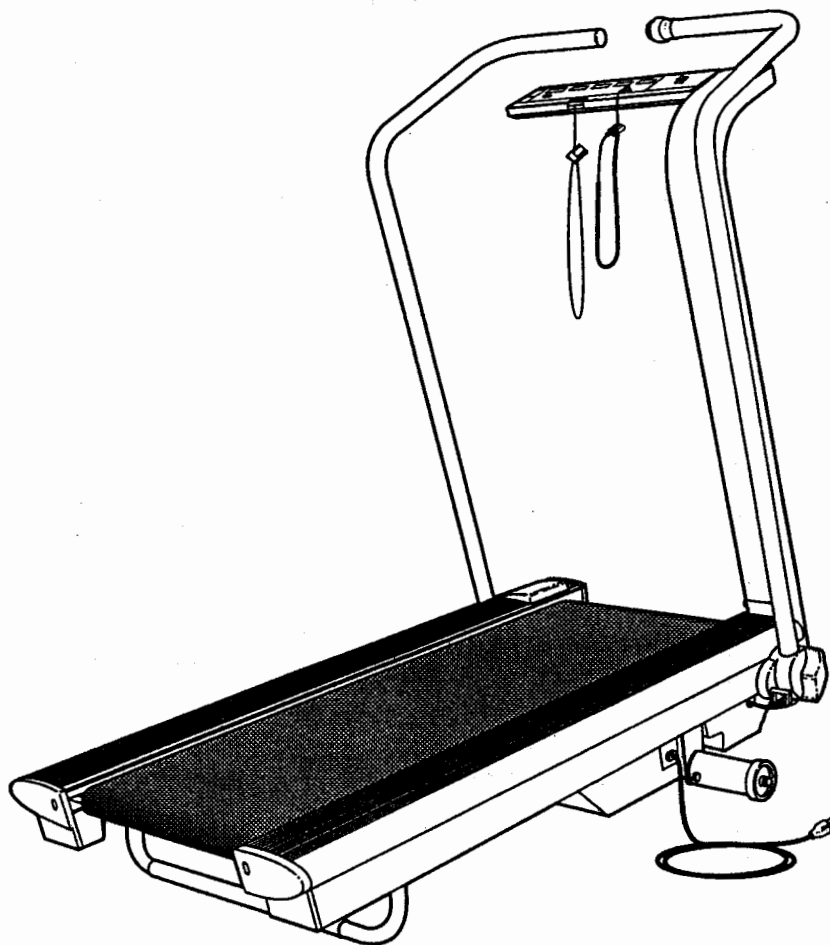

# OWNER'S MANUAL

## LIMITED WARRANTY

ICON Health & Fitness, Inc. ("ICON"), warrants this product to be free from defects in workmanship and material, under normal use and service conditions, for a period of ninety (90) days from the date of purchase. This warranty extends only to the original purchaser. ICON's obligation under this warranty is limited to replacing or repairing, at ICON's option, the product at one of its authorized service centers. All products for which warranty claim is made must be received by ICON at one of its authorized service centers with all freight and other transportation charges prepaid, accompanied by sufficient proof of purchase. All returns must be pre-authorized by ICON. This warranty does not extend to any product or damage to a product caused by or attributable to freight damage, abuse, misuse, improper or abnormal usage or repairs not provided by a ICON authorized service center or for products used for commercial or rental purposes. No other warranty beyond that specifically set forth above is authorized by ICON.

ICON IS NOT RESPONSIBLE OR LIABLE FOR INDIRECT, SPECIAL OR CONSEQUENTIAL DAMAGES ARISING OUT OF OR IN CONNECTION WITH THE USE OR PERFORMANCE OF THE PRODUCT OR OTHER DAMAGES WITH RESPECT TO ANY ECONOMIC LOSS, LOSS OF PROPERTY, LOSS OF REVENUES OR PROFITS, LOSS OF ENJOYMENT OR USE, COSTS OF REMOVAL, INSTALLATION OR OTHER CONSEQUENTIAL DAMAGES OF WHATSOEVER NATURE. SOME STATES DO NOT ALLOW THE EXCLUSION OR LIMITATION OF INCIDENTAL OR CONSEQUENTIAL DAMAGES. ACCORDINGLY, THE ABOVE LIMITATION MAY NOT APPLY TO YOU.

THE WARRANTY EXTENDED HEREUNDER IS IN LIEU OF ANY AND ALL OTHER WARRANTIES AND ANY IMPLIED WARRANTIES OF MERCHANTABILITY OR FITNESS FOR A PARTICULAR PURPOSE IS LIMITED IN ITS SCOPE AND DURATION TO THE TERMS SET FORTH HEREIN. SOME STATES DO NOT ALLOW LIMITATIONS ON HOW LONG AN IMPLIED WARRANTY LASTS. ACCORDINGLY, THE ABOVE LIMITATION MAY NOT APPLY TO YOU.

This warranty gives you specific legal rights. You may also have other rights which vary from state to state.

**ICON HEALTH & FITNESS, Inc. 1500 S. 1000 W., LOGAN UT 84321-9813**

**PRO-FORM<sup>®</sup>**  
**CROSS**  **WALK<sup>™</sup>**  

---

**plus**

---

**TABLE OF CONTENTS**

IMPORTANT PRECAUTIONS .....4  
BEFORE YOU BEGIN .....5  
ASSEMBLY .....6  
OPERATION AND ADJUSTMENT .....7  
TROUBLE-SHOOTING AND STORAGE .....10  
.CONDITIONING GUIDELINES .....12  
PART LIST .....14  
EXPLODED DRAWING .....15  
ORDERING REPLACEMENT PARTS .....Back Cover

**▲ WARNING:** Before beginning this or any exercise program, consult your physician. This is especially important for persons over the age of 35 or persons with pre-existing health problems. Read all instructions before using. ICON assumes no responsibility for personal injury or property damage sustained by or through the use of this product.

---

## IMPORTANT PRECAUTIONS

**⚠ WARNING:** To reduce the risk of burns, fire, electric shock or injury to persons, read the following important precautions and information before operating the treadmill.

1. Position the treadmill on a level surface, with at least 8 feet of clearance behind the treadmill. Do not place the treadmill near water, outdoors or on a surface that blocks any air openings. Do not operate where aerosol products are used or where oxygen is being administered.
2. When connecting the power cord (see PLUGGING IN THE POWER CORD on page 7), plug the power cord directly into a grounded circuit capable of carrying 12 or more amps. No other appliance should be on the same circuit. Keep the power cord away from heated surfaces. If an extension cord is needed, use only a 14-gauge general-purpose cord of five feet or less in length with a three-wire conductor.
3. Never move the walking belt while the power is turned off. Do not operate the treadmill if the power cord or plug is damaged, or if the treadmill is not working properly. (See BEFORE YOU BEGIN on page 5 if the treadmill is not working properly.)
4. Wear appropriate exercise clothing when using the treadmill; do not wear loose clothing that could become caught in the treadmill. *Always wear athletic shoes; never use the treadmill with bare feet, wearing only stockings or in sandals.* Athletic support clothes are recommended for both men and women.
5. The pulse earclip is not a medical device. Various factors, including the user's movement while exercising, may affect the accuracy of heart rate readings. The earclip is intended only as an exercise aid in determining heart rate trends in general.
6. Never start the treadmill while you are standing on the walking belt. Always hold the dual action arms when exercising on the treadmill.
7. Never allow more than one person on the treadmill at a time. The treadmill should not be used by persons weighing more than 250 pounds.
8. Keep small children away from the treadmill at all times.
9. Never leave the treadmill unattended while it is running. Always remove the safety key when the treadmill is not in use.
10. Never drop or insert any object into any opening.
11. To reduce the possibility of overheating, do not operate the treadmill continuously for longer than 1 hour.
12. The treadmill is capable of high speeds. Adjust the speed in small increments to avoid sudden jumps in speed.
13. Use the treadmill only as described in this manual.
14. Always unplug the power cord before performing the maintenance and adjustment procedures described in this manual. Never remove the safety cover unless instructed to do so by an authorized service representative. Servicing other than the procedures in this manual should be performed by an authorized service representative only.

## SAVE THESE INSTRUCTIONS

# BEFORE YOU BEGIN

Thank you for selecting the PROFORM® CROSSWALK™ PLUS treadmill. The CROSSWALK PLUS treadmill blends advanced technology with innovative design to let you enjoy an excellent form of cardiovascular exercise in the convenience and privacy of your home.

**For your benefit, read this manual carefully before using the treadmill.** If you have additional questions, please call our Customer Service Department toll-free at 1-800-999-3756, Monday through Friday, 6 a.m. until 6 p.m. Mountain Time (excluding holidays). To help us assist you, please note the product model number and serial number before calling. The model number of the treadmill is DRTL00740/PFTL00740. The serial number can be found on a decal attached to the treadmill (see the front cover of this manual for the location).

Before reading further, please review the drawing below and familiarize yourself with the parts that are labeled.

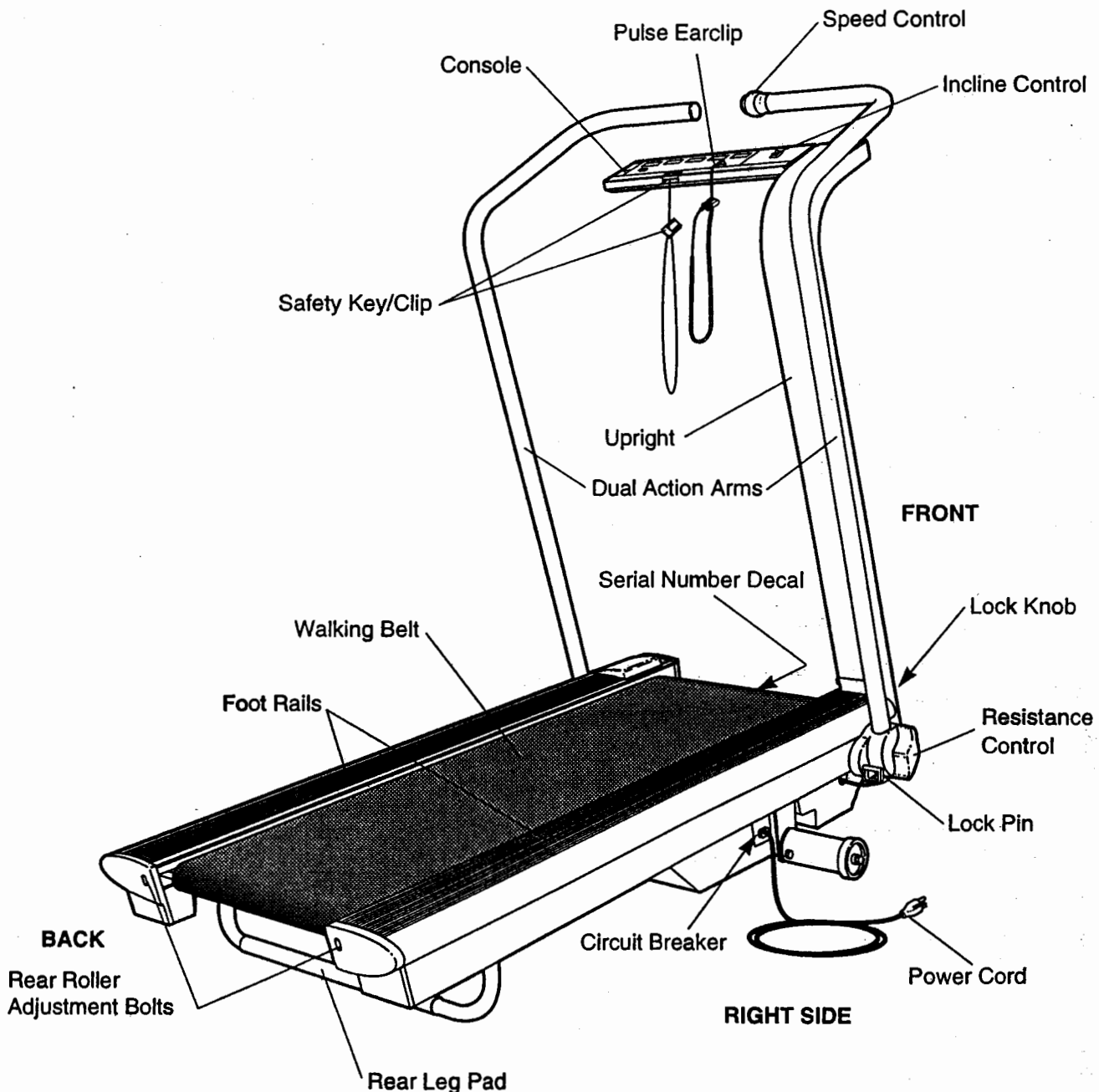

Note: The rear leg pad may mark some types of linoleum. Mild household cleaning agents will remove any marks.

# ASSEMBLY

The treadmill is delivered in the compact stowaway position. Set the treadmill in a cleared area and remove all packing materials. **Do not dispose of the packing materials until assembly is completed.**

1. To convert the treadmill to the operating position, first raise the Upright (15) to a vertical position. Insert the Lock Knob (24), with the Lock Knob Washer (23), into the Upright. Turn the Lock Knob clockwise until it is tight:

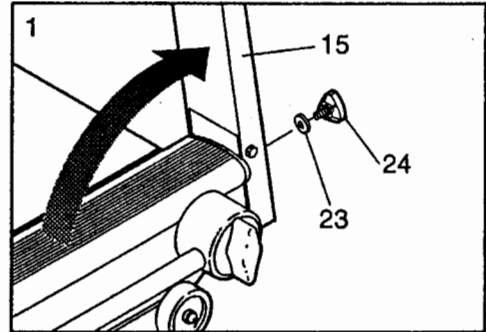

2. Raise the Right Dual Action Arm (14) to a vertical position. Insert a Lock Pin (19) through the Dual Action Arm and into the treadmill Frame (56). Make sure that the Lock Pin is fully inserted. Firmly tighten the Resistance Control (27). The Dual Action Arm is now in the stationary position. (See OPERATING THE DUAL ACTION ARMS on page 9.)

Insert a Lock Pin (19) into the Left Dual Action Arm (not shown) in the same manner.

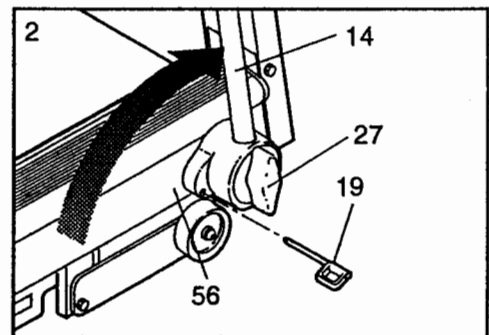

3. Remove the paper backing from the Wrench Clip (70). Press the Wrench Clip onto the Right Rear Endcap (62) in the indicated location. Press the Allen Wrench (69) into the Wrench Clip.

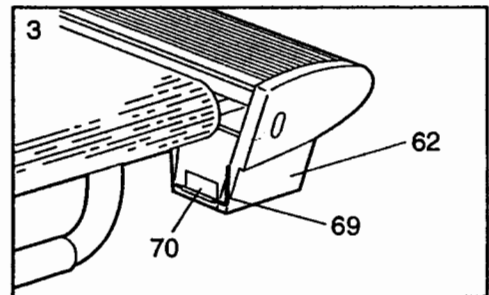

4. Slide the metal Clothes Clip onto the Pulse Earclip in the indicated location. The use of the Pulse Earclip is explained in MOTIVATIONAL FITNESS MONITOR OPERATION on page 9.

Make sure that all parts are properly tightened before you use the treadmill. **Note: It is recommended that the floor under the treadmill be covered for protection.**

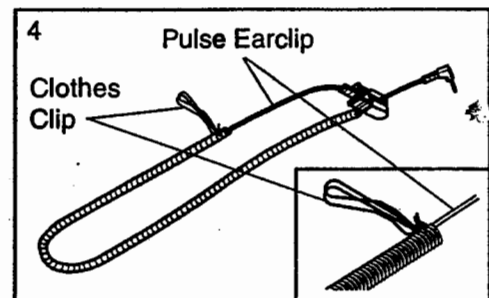

# OPERATION AND ADJUSTMENT

## MAINTENANCE-FREE WALKING BELT

Your treadmill features a maintenance-free walking belt coated with PERFORMANT LUBE™, a high-performance lubricant.

During the first few hours of use, it is normal for a small amount of white powder to appear on the foot rails and the walking platform. The white powder is high-performance lubricant from the walking belt.

**IMPORTANT:** Never apply silicone spray or other substances to the walking belt or the walking platform. They will deteriorate the walking belt and cause excessive wear.

## PLUGGING IN THE POWER CORD

**This product must be grounded.** If it should malfunction or break down, grounding provides a path of least resistance for electric current to reduce the risk of electric shock. This product is equipped with a cord having an equipment-grounding conductor and a grounding plug. **Plug the power cord into an appropriate outlet that is properly installed and grounded in accordance with all local codes and ordinances.**

**⚠ DANGER:** Improper connection of the equipment-grounding conductor can result in a risk of electric shock. Check with a qualified electrician or serviceman if you are in doubt as to whether the product is properly grounded. Do not modify the plug provided with the product—if it will not fit the outlet, have a proper outlet installed by a qualified electrician.

This product is for use on a nominal 120-volt circuit, and has a grounding plug that looks like the plug illustrated in Drawing 1. A temporary adapter that looks like the adapter illustrated in Drawing 2 may be used to connect this plug to a 2-pole receptacle as shown in Drawing 2 if a properly grounded outlet is not available. The temporary adapter should be used only until a properly grounded outlet (Drawing 1) can be installed by a qualified electrician. The green colored rigid ear, lug, or the like extending from the adapter **must be connected to a permanent ground** such as a properly grounded outlet box cover. Whenever the adapter is used it **must be held in place by a metal screw**.

**Some 2-pole receptacle outlet box covers are not grounded. Contact a qualified electrician to determine if the outlet box cover is grounded before using an adapter.**

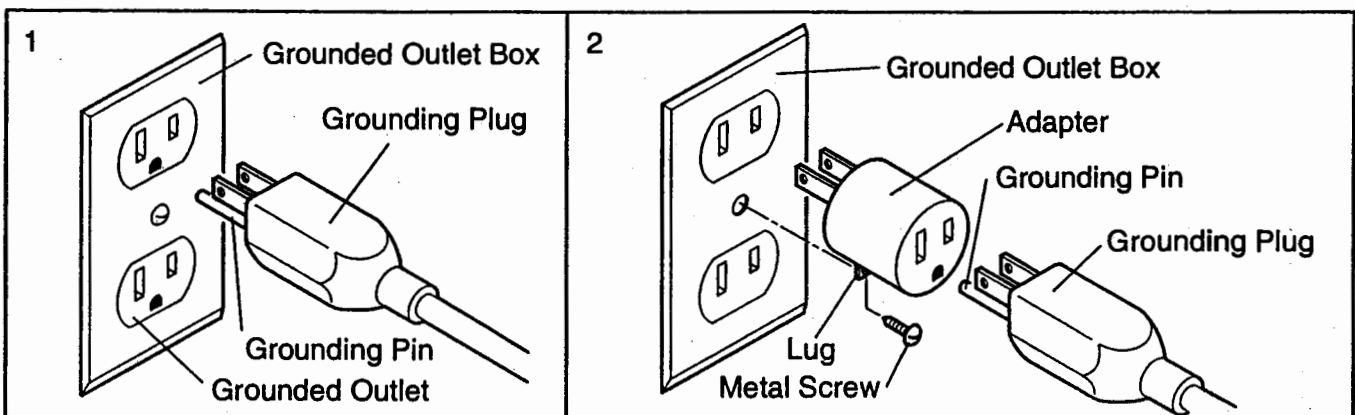

## DIAGRAM OF THE CONSOLE

The heart of the treadmill is the electronic console. The console features a safety key-operated power switch, electronic speed and incline controls and five independent displays to give you continuous exercise feedback. **Please read these instructions carefully before operating the console. Note: If there is a thin sheet of clear protective plastic on the face of the console, peel it off before operating the console.**

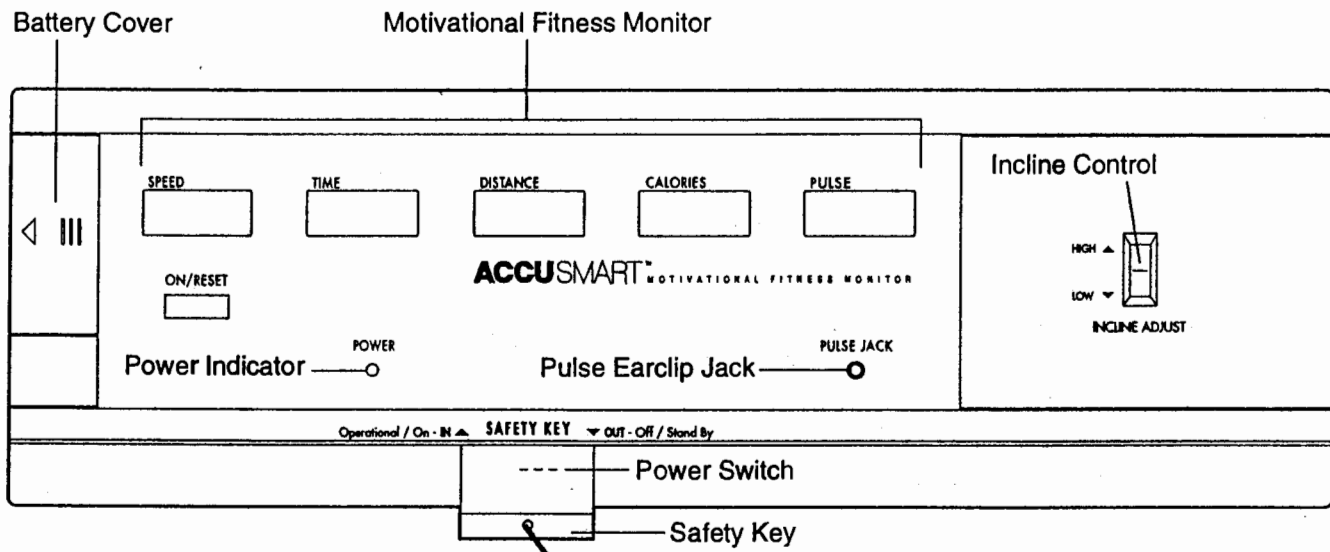

## INSTALLING BATTERIES

The motivational fitness monitor requires two "AA" batteries (not included); alkaline batteries are recommended. Slide off the battery cover. Remove the battery clip from the console. Find the markings inside the battery clip showing which direction the batteries should be turned. Press the batteries into the battery clip. Replace the battery clip in the console and close the battery cover.

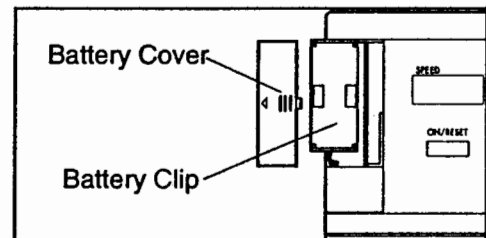

## TURNING ON THE POWER

Step onto the foot rails of the treadmill. Locate the clip attached by a cord to the safety key, and slide the clip onto the waistband of your clothing.

**CAUTION:** Do not stand on the walking belt when turning on the power. Always wear the clip while operating the treadmill.

Insert the safety key into the power switch. The power indicator will light. The five displays of the motivational fitness monitor will not appear until the ON/RESET button is pressed, or the walking belt begins to move (see CONTROLLING THE SPEED below). Note: If batteries were just installed, the five displays will already appear.

## CONTROLLING THE SPEED

To start the walking belt, first turn the speed control until the ridge on the control is even with the word, "RESET." Then, slowly turn the control until the walking belt begins to move at slow speed.

**CAUTION:** After the speed control is turned, there will be a pause before the walking belt begins to move. Adjust the speed slowly until you are familiar with the operation of the treadmill. Be careful not to bump the speed control while using the arms in the dual motion position.

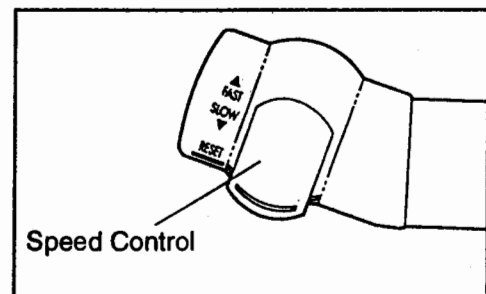

Carefully step onto the walking belt and begin exercising. Change the speed of the walking belt as desired by turning the speed control. To stop the walking belt, turn the control to "RESET."



## CHANGING THE INCLINE

The incline of the treadmill can be changed using the incline control on the right side of the console. To increase the incline, press the end of the switch farthest from you. To decrease the incline, press the end of the switch closest to you.

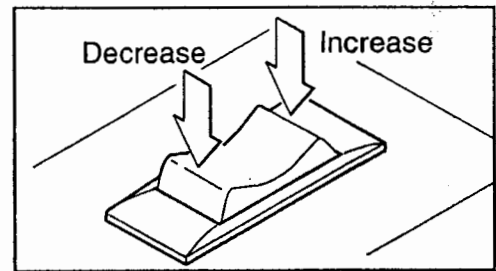

## OPERATING THE DUAL ACTION ARMS

The dual action arms can be used in either the stationary position or the dual motion position. To use the dual action arms in the stationary position, insert a lock pin through the base of each arm and into the treadmill frame. Make sure that the pins are fully inserted. Firmly tighten the resistance control.

To use the dual action arms in the dual motion position, first make sure that the resistance control is tightened. Remove the lock pin from each arm. Store the lock pins in a secure place. In the dual motion position, you can move the arms forward and back as you walk or run, exercising your arms, back and shoulders for a total body workout. *Do not use the dual action arms for support while the arms are in the dual motion position.* To adjust the intensity of your exercise, the resistance of the arms can be changed. To increase the resistance, turn the resistance control clockwise; to decrease the resistance, turn the control counterclockwise.

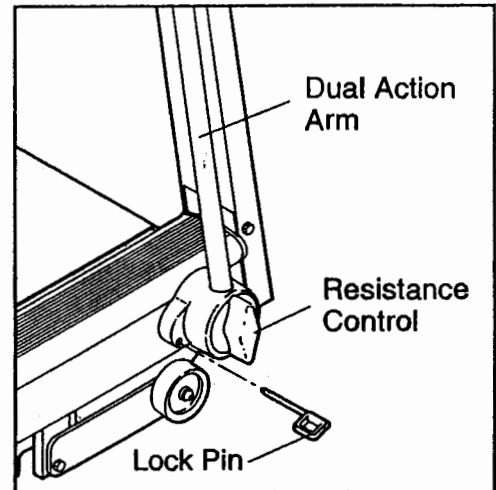

## MOTIVATIONAL FITNESS MONITOR OPERATION

The five displays of the motivational fitness monitor provide continuous exercise feedback. The displays can be reset by pressing the ON/RESET button. The five displays are described below:

**SPEED**—This display shows the current speed of the walking belt, in miles per hour.

**TIME**—This display shows the elapsed time. Note: When the walking belt is stopped, the TIME display will go into a pause mode after a few seconds.

**DISTANCE**—This display shows the total distance that you have walked or run, in miles.

**CALORIES**—This display shows the approximate number of nutritional Calories that you have burned.

**PULSE**—This display shows your heart rate. Plug the pulse earclip into the jack on the console, and attach the earclip to your left ear lobe. Slide the metal clothes clip on the earclip wire onto your collar. After a few seconds, your heart rate will be displayed. If your heart rate is not displayed, rub your ear lobe and reposition the earclip. It may be helpful to stand still while measuring your heart rate.

**Note:** If the walking belt is stopped and remains stationary for about four minutes, the five displays of the motivational fitness monitor will be reset and will darken, although the power will remain on. The five displays will appear again when the ON/RESET button is pressed, or the walking belt is restarted.

## TURNING OFF THE POWER

To turn off the power, remove the safety key from the console. The power indicator will darken. *Store the safety key in a secure location.*

# TROUBLE-SHOOTING AND STORAGE

Most treadmill problems can be solved by following the simple steps below. Find the symptom that applies to your treadmill and follow the steps listed. If further assistance is needed, please call our Customer Service Department toll-free at 1-800-999-3756, Monday through Friday, 6 a.m. until 6 p.m. Mountain Time (excluding holidays).

## 1. SYMPTOM: THE POWER DOES NOT TURN ON

- a. Make sure that the power cord is plugged into a properly grounded outlet. (See PLUGGING IN THE POWER CORD on page 7.) If an extension cord is needed, use only a 14-gauge general-purpose cord of five feet or less in length.
- b. After the power cord has been plugged in, make sure that the safety key is fully inserted into the console. Various indicators on the console should light. (See TURNING ON THE POWER on page 8.)
- c. Check the circuit breaker located on the treadmill frame near the power cord. If the switch protrudes as shown, the circuit breaker has tripped. To reset the circuit breaker, wait for five minutes and then press the switch back in.

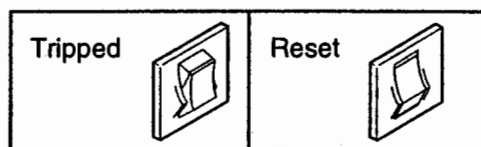

## 2. SYMPTOM: THE POWER TURNS OFF DURING USE

- a. Check the circuit breaker located on the treadmill frame near the power cord. If the circuit breaker has tripped, the switch will protrude. (See the drawing above.) To reset the circuit breaker, wait for five minutes and then press the switch back in.
- b. Make sure that the power cord is plugged in.
- c. Remove the safety key from the console. Reinsert the safety key fully into the console. Various indicators on the console should light.

## 3. SYMPTOM: THE PULSE EARCLIP DOES NOT FUNCTION PROPERLY

- a. Make sure that the pulse earclip is plugged fully into the jack on the console.
- b. Stand still while measuring your pulse.
- c. Rub your left ear lobe and reposition the earclip. Attach the clothes clip to your collar.
- d. The pulse earclip may need to be cleaned. Press the earclip open, and find the two clear circles inside the earclip. Wipe the two clear circles using a cotton swab moistened with water.

**⚠ WARNING:** The pulse earclip is not a medical device. Various factors, including the user's movement while exercising, may affect the accuracy of heart rate readings. The earclip is intended only as an exercise aid in determining heart rate trends in general.

## 4. SYMPTOM: THE MOTIVATIONAL FITNESS MONITOR DOES NOT FUNCTION PROPERLY

- a. Check the batteries in the console. (See INSTALLING BATTERIES on page 8.) Most problems are the result of drained batteries.

## 5. SYMPTOM: THE WALKING BELT SLOWS WHEN WALKED ON

- a. If an extension cord is needed, use only a 14-gauge general-purpose cord of five feet or less in length.

- b. If the walking belt is overtightened, treadmill performance may decrease and the walking belt may be permanently damaged. Remove the safety key and **UNPLUG THE POWER CORD**. Using the allen wrench, turn both rear roller adjustment bolts counterclockwise, 1/4 of a turn. When the walking belt is properly tightened, you should be able to lift each side of the walking belt 3–4 inches off the walking platform. The center of the walking belt should just touch the walking platform. Be careful to keep the walking belt centered. Plug in the power cord, insert the safety key and run the treadmill for a few minutes. Repeat until the walking belt is properly tightened.

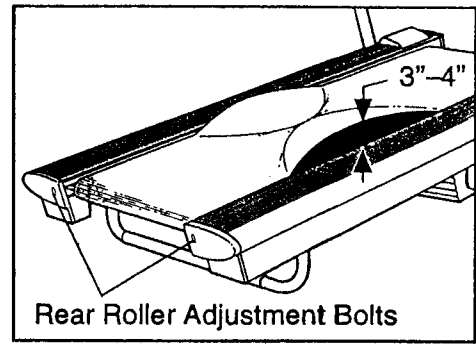

- c. If the walking belt still slows when walked on, please call our Customer Service Department.

## 6. SYMPTOM: THE WALKING BELT IS OFF-CENTER OR SLIPS WHEN WALKED ON

- a. If the walking belt has shifted to the left, first remove the safety key and **UNPLUG THE POWER CORD**. Using the allen wrench, turn the left rear roller adjustment bolt clockwise, and the right bolt counterclockwise, 1/4 of a turn each. Be careful not to overtighten the walking belt. Plug in the power cord, insert the safety key and run the treadmill for a few minutes. Repeat until the walking belt is centered.

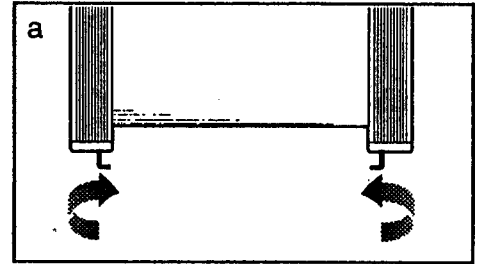

- b. If the walking belt has shifted to the right, first remove the safety key and **UNPLUG THE POWER CORD**. Using the allen wrench, turn the left rear roller adjustment bolt counterclockwise, and the right bolt clockwise, 1/4 of a turn each. Be careful not to overtighten the walking belt. Plug in the power cord, insert the safety key and run the treadmill for a few minutes. Repeat until the walking belt is centered.

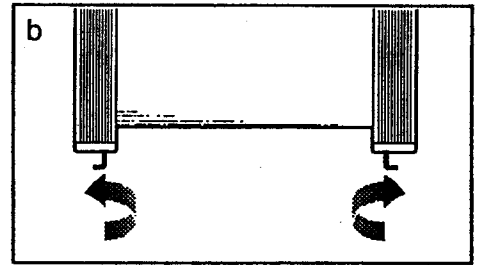

- c. If the walking belt slips when walked on, first remove the safety key and **UNPLUG THE POWER CORD**. Using the allen wrench, turn both rear roller adjustment bolts clockwise, 1/4 of a turn. When the walking belt is correctly tightened, you should be able to lift each side of the walking belt 3–4 inches off the walking platform. The center of the walking belt should just touch the walking platform. Be careful to keep the walking belt centered. Plug in the power cord, insert the safety key and run the treadmill for a few minutes. Repeat until the walking belt is properly tightened.

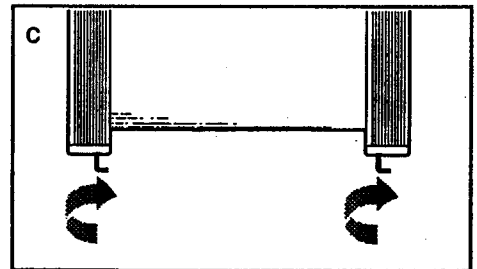

## STORAGE

Unplug the power cord when storing the treadmill. Remove the Lock Pin (19) from the Right Dual Action Arm (14) (see drawing 1). Lower the Arm. Remove the Lock Pin from the Left Dual Action Arm (not shown). Lower the Arm.

Remove the Lock Knob (24) and Lock Knob Washer (23) from the Upright (15) (see drawing 2). Lower the Upright onto the walking belt. Store the Washer, Knob and Lock Pins in a secure location.

It is recommended that the treadmill be covered during extended periods of storage.

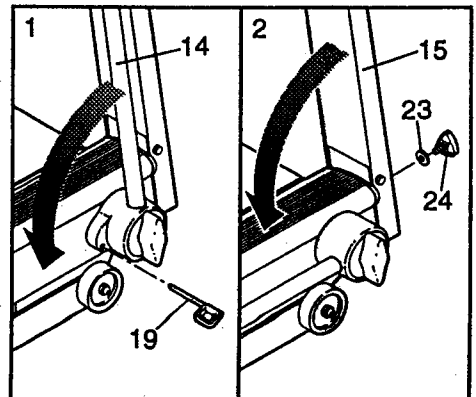

# CONDITIONING GUIDELINES

The following guidelines will help you to plan your exercise program. Remember that proper nutrition and adequate rest are essential for successful results.

**⚠ WARNING:** Before beginning this or any exercise program, consult your physician. This is especially important for individuals over the age of 35 or individuals with pre-existing health problems.

## EXERCISE INTENSITY

To maximize the benefits of exercising, it is important to exercise with the proper intensity. The proper intensity level can be found by using your heart rate as a guide. For effective aerobic exercise, your heart rate should be maintained at a level between 70% and 85% of your maximum heart rate as you exercise. This is known as your training zone. You can find your training zone in the table below.

AGE	UNCONDITIONED TRAINING ZONE (BEATS/MIN)	CONDITIONED TRAINING ZONE (BEATS/MIN)	AGE	UNCONDITIONED TRAINING ZONE (BEATS/MIN)	CONDITIONED TRAINING ZONE (BEATS/MIN)
20	138-167	133-162	55	127-155	122-149
25	136-166	132-160	60	126-153	121-147
30	135-164	130-158	65	125-151	119-145
35	134-162	129-156	70	123-150	118-144
40	132-161	127-155	75	122-147	117-142
45	131-159	125-153	80	120-146	115-140
50	129-156	124-150	85	118-144	114-139

During the first few months of your exercise program, keep your heart rate near the low end of your training zone as you exercise. After a few months of regular exercise, your heart rate can be increased gradually until it is near the middle of your training zone as you exercise. You can measure your heart rate using the pulse mode of the console. Exercise for at least four minutes, and then measure your heart rate immediately. If your heart rate is too high, decrease the intensity of your exercise. If your heart rate is too low, increase the intensity of your exercise.

**⚠ WARNING:** The pulse earclip is not a medical device. Various factors, including your movement during exercise, may affect the accuracy of heart rate readings. The earclip is intended only as an exercise aid in determining heart rate trends in general.

## WORKOUT GUIDELINES

Each workout should consist of three basic parts: a warm-up, 20 to 30 minutes of training zone exercise, and a cool-down. Warming up prepares the body for exercise by increasing circulation, delivering more oxygen to the muscles and raising the body temperature. Begin each workout with 5 to 10 minutes of stretching and light exercise to warm up. Then, increase the intensity of your exercise to raise your heart rate to your training zone for 20 to 30 minutes. Breathe regularly and deeply as you exercise—never hold your breath. Finish each workout with 5 to 10 minutes of stretching to cool down. This will increase the flexibility of your muscles as well as help to decrease soreness and other post-exercise problems.

To maintain or improve your condition, complete three workouts each week, with at least one day of rest between workouts. After a few months of regular exercise, you may complete up to five workouts each week, if desired. The key to success is CONSISTENCY.

## SUGGESTED STRETCHES

The following stretches can provide a good warm-up or cool-down. Correct form for each stretch is shown in the drawings below. Move slowly as you stretch—never bounce.

### TOE TOUCH STRETCH

Stand with your knees bent slightly and slowly bend forward from your hips. Allow your back and shoulders to relax as you reach down toward your toes as far as possible. Hold for 15 counts, then relax. Repeat 3 times.

Stretches: Hamstrings, back of knees and back.

### HAMSTRING STRETCH

Sit with one leg extended. Bring the sole of the opposite foot toward you and rest it against the inner thigh of your extended leg. Reach toward your toes as far as possible. Hold for 15 counts, then relax. Repeat 3 times for both legs.

Stretches: Hamstrings, lower back and groin.

### CALF/ACHILLES STRETCH

With one leg in front of the other, reach forward and place your hands against a wall. Keep your back leg straight and your back foot flat on the floor. Bend your front leg, lean forward and move your hips toward the wall. Hold for 15 counts, then relax. Repeat 3 times for both legs. To cause further stretching of the achilles tendons, bend your back leg as well.

Stretches: Calves, achilles tendons and ankles.

### QUADRICEPS STRETCH

With one hand against a wall for balance, reach back and grasp one foot with your other hand. Bring your heel as close to your buttocks as possible. Hold for 15 counts, then relax. Repeat 3 times for both legs.

Stretches: Quadriceps and hip muscles.

### INNER THIGH STRETCH

Sit with the soles of your feet together and your knees outward. Pull your feet toward your groin area as far as possible. Hold for 15 counts, then relax. Repeat 3 times.

Stretches: Quadriceps and hip muscles.

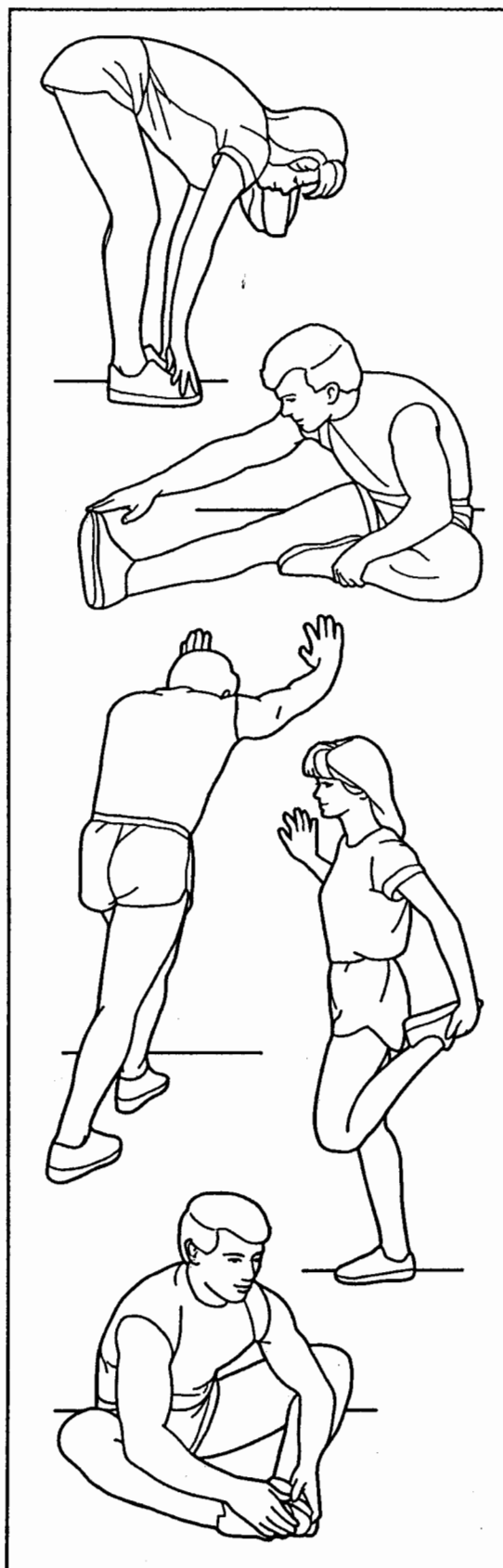

# PART LIST—Model No. DRTL00740/PFTL00740

R595A

Key No.	Qty.	Description	Key No.	Qty.	Description
1	1	Left Dual Action Arm/Housing	57	1	Front Safety Cover
2	1	Pulse Earclip/Clothes Clip	58	1	Back Safety Cover
3	1	Safety Key/Clip	59	1	Walking Belt
4	1	Console	60	1	Right Foot Rail
5	7	Screw	61	1	Rear Leg Pad
6	1	Power Switch Wire	62	1	Right Rear Endcap
7	1	Incline Control Switch	63	5	8" Cable Tie
8	1	Speed Control	64	2	4" Cable Tie
9	1	Speed Control Wire	65	2	Rear Roller Adj. Bolt
10	1	Speed Knob Screw	66	1	Incline Motor Bracket
11	1	Upright Endcap	67	1	Pulley/Flywheel/Fan
12	1	Lift Wire	68	1	Choke Guard
13	1	6" Cable Loom	69	1	Allen Wrench
14	1	Right Dual Action Arm/Housing	70	2	Wrench Clip
15	1	Upright	71	1	Rear Roller
16	1	Front Left Endcap	72	1	Left Rear Endcap
17	1	Front Roller/Pulley	73	2	Foot Rail Mounting Track
18	1	12" Cable Loom	74	8	Platform Screw
19	2	Lock Pin	75	1	Walking Platform
20	3	Roller Adjustment Washer	76	2	Platform Shim
21	1	Front Roller Adj. Bolt	77	1	Left Foot Rail
22	1	Left Housing	78	1	Resistance Bolt
23	1	Upright Knob Washer	79	1	Resistance Housing Cap
24	1	Upright Knob	80	8	Deck Bracket Screw
25	1	Cage Nut	81	1	Right Friction Plate
26	1	Hinge Bolt	82	1	Motor Mounting Bracket
27	1	Resistance Control	83	1	Belt
28	2	Thrust Bearing	84	2	Motor Bolt
29	3	Thrust Washer	85	1	Motor
30	2	Leather Pad	86	1	Reed Switch Extension Wire
31	1	Left Friction Plate	87	1	Reed Switch Wire
32	1	Belt Guide	88	2	Cover Washer
33	1	Strain Relief	89	1	Long Safety Cover Screw
34	1	Dual Action Arm Endcap	90	2	Motor Nut
35	1	Front Right Endcap	91	1	Motor Swivel Bolt
36	1	Electronics Mounting Bracket	92	2	Incline Leg Washer
37	1	Circuit Breaker	93	1	Motor Lock Nut
38	1	Power Cord Grommet	94	1	Choke Bracket
39	1	Power Cord	95	4	Wire Clip
40	1	Controller	96	1	Upright Pivot Washer
41	2	Front Wheel Nut	97	7	Electronics Screw
42	2	Front Wheel	98	7	Console Screw
43	2	Wheel Bolt	99	2	Hardened Washer
44	1	Right Housing	100	1	Tie Holder
45	3	Incline Leg Bolt/Motor Tension Bolt	101	1	Tie
46	6	Lock Nut	102	3	Belt Guide Screw
47	4	Plastic Stand-Off	103	1	Star Washer
48	1	Lift Board	#	1	14" Blue Wire, Male/Female
49	1	Choke	#	1	8" Blue Wire, 2 Female
50	14	Belly Pan Screw	#	1	8" Blue Wire, Male/Female
51	1	Incline Leg	#	1	14" White Wire, 2 Male/Female
52	2	Incline Motor Bolt	#	1	14" White Wire, 2 Female
53	1	Lift Motor Spacer	#	1	14" Black Wire, Male/Female
54	4	Rear Endcap Screw	#	1	9" Black Wire, Male/Female
55	1	Incline Motor	#	1	8" Red Wire, Male/Female
56	1	Frame	#	1	Owner's Manual

# EXPLODED DRAWING—Model No. DRTL00740/PFTL00740

R595A

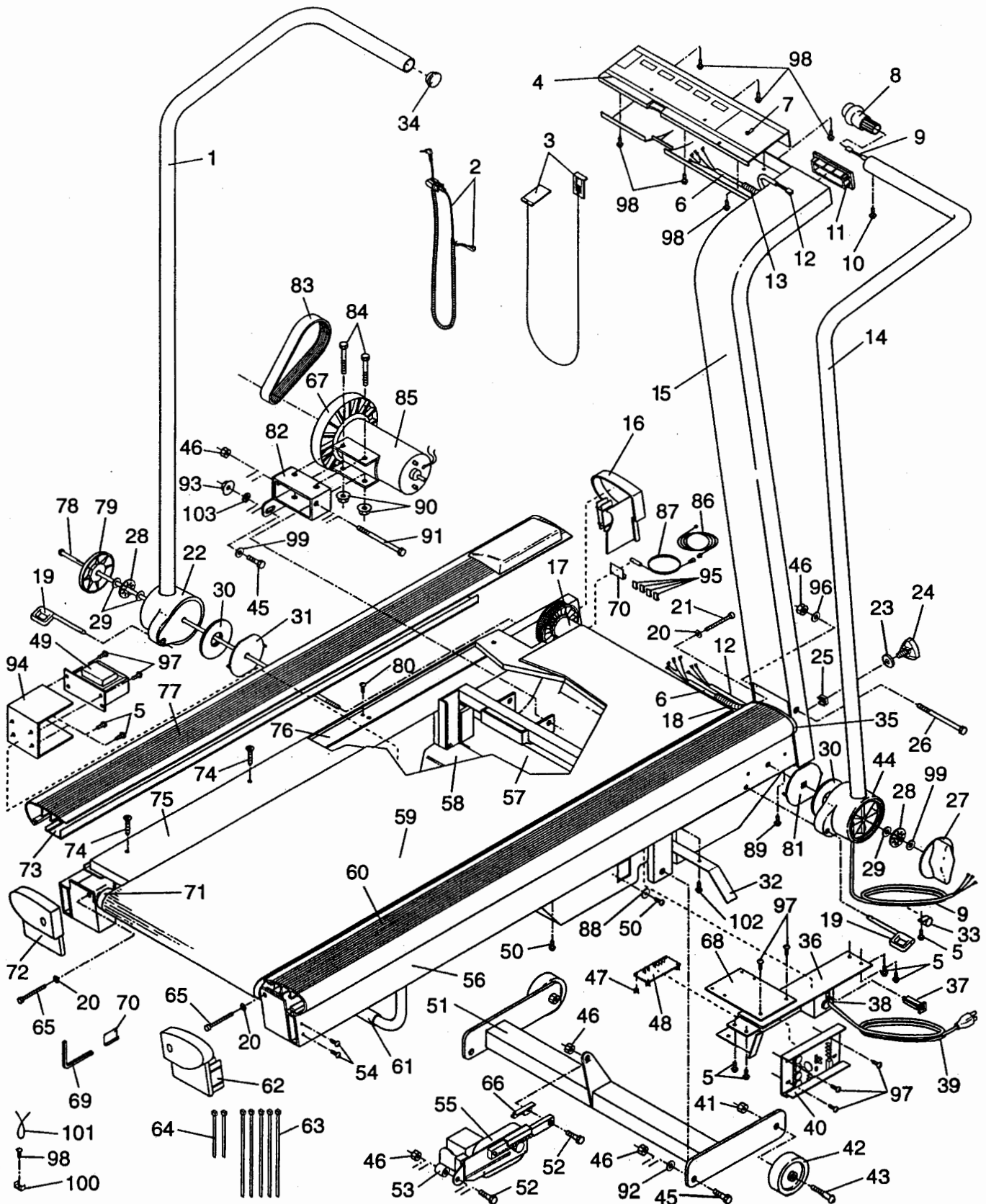

---

# ORDERING REPLACEMENT PARTS

To order replacement parts, call our Customer Service Department toll-free at 1-800-999-3756, Monday through Friday, 6 a.m. until 6 p.m. Mountain Time (excluding holidays). When ordering parts, please be prepared to give the following information:

- The MODEL NUMBER of the product (DRTL00740/PFTL00740).
- The NAME of the product (PROFORM® CROSSWALK™ PLUS treadmill).
- The SERIAL NUMBER of the product (see the front cover of this manual).
- The KEY NUMBER of the part(s) from page 14 of this manual.
- The DESCRIPTION of the part(s) from page 14 of this manual.

If possible, place the treadmill near your telephone for easy reference when calling.

