

PRO-FORM[®]

RESTORATION 3100

Class HC Fitness Product

Model No. PERX31090

Serial No. _____

The serial number can be found in the location shown below. Write the serial number in the space above.

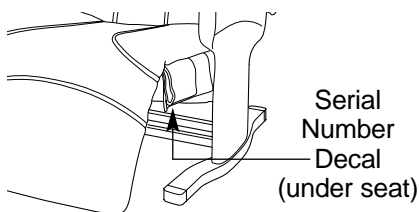

USER'S MANUAL

QUESTIONS?

As a manufacturer, we are committed to providing complete customer satisfaction. If you have questions, or if there are missing parts, we will guarantee complete satisfaction through our Customer Service Department.

Please CALL:
0345-089009

Or WRITE:
ICON Fitness Lifestyle Ltd.
Greenwich House
223 North Street
Sheepscar
West Yorkshire
Leeds LS7 2AA



CAUTION

Read all precautions and instructions in this manual before using this equipment. Save this manual for future reference.



Visit our website at

www.proform.com

*new products, prizes,
fitness tips, and much more!*

PRO·FORM[®]

RESTORATION 3100

Table of Contents

Important Precautions 3
Before You Begin 4
Assembly 5
How to Operate the Massage Chair 7
Maintenance 10
Notes 11
Ordering Replacement Parts Back Cover

Note: A PART LIST and an EXPLODED DRAWING are attached in the centre of this manual. Remove the PART LIST and the EXPLODED DRAWING before beginning assembly.

Important Precautions

WARNING: To reduce the risk of burns, fire, electric shock or serious injury to persons, read all important precautions before using the massage chair.

READ AND FOLLOW ALL INSTRUCTIONS

1. Read all precautions and instructions in this manual before using the massage chair.
2. It is the responsibility of the owner to ensure that all users of the massage chair are adequately informed of all precautions.

WARNING

To reduce the risk of burns, fire, electric shock, or injury to persons:

3. Never leave the massage chair unattended while it is plugged in.
4. Close supervision is necessary when the massage chair is used by, on, or near invalids or disabled persons.
5. Keep children under the age of 12 away from the massage chair.
6. Use the massage chair only for its intended use as described in this manual.
7. Never operate the massage chair if it is not working properly, if it is damaged, or if the power cord or plug is damaged. If any of these conditions exists, please call the telephone number on the front of this manual.
8. When connecting the power cord (see HOW TO PLUG IN THE POWER CORD on page 7), plug the power cord into an earthed circuit. When replacing the fuse, only a ASTA approved BS1362 type should be fitted to the fuse carrier. A 13 amp fuse should be used.

WARNING: Read all instructions before using this product. ICON assumes no responsibility for personal injury or property damage sustained by or through the use of this product.

SAVE THESE INSTRUCTIONS

No other appliance should be on the same circuit.

9. Keep the power cord away from heated surfaces.
10. Use the massage chair indoors. Never use the massage chair outdoors.
11. The massage chair is intended for home use only. Do not use the massage chair in a commercial, rental or institutional setting.

DANGER

To reduce the risk of electric shock:

12. Keep the power cord and the surge suppressor away from heated surfaces.
13. Always turn off the hand control and unplug the power cord from the outlet immediately after using and before cleaning the massage chair.

DANGER

14. Keep pins and other sharp objects away from the massage chair.
15. Carefully examine the massage chair before each use. If there are any signs of deterioration, call the toll-free telephone number on the front of this manual.
16. Keep the massage chair dry, away from water and moisture.

Before You Begin

Congratulations for selecting the PROFORM® RESTORATION 3100 massage chair. The innovative RESTORATION 3100 massage chair is designed to melt away stress—relaxing you, stimulating circulation and reducing muscle fatigue—any time you choose. The convenient hand control allows you to choose upper-back, lower-back or whole-back massage. You can also choose between six massage programs.

Please read this manual carefully before you use the RESTORATION 3100. If you have additional

questions, please call our Customer Service Department at 0345-089009. To help us assist you, please mention the product model number and serial number when calling. The model number is PERX31090. The serial number can be found on a decal attached to the massage chair (see the front cover of this manual for the location of the decal).

Before assembling the massage chair, please look at the drawing below and familiarise yourself with the parts that are labelled.

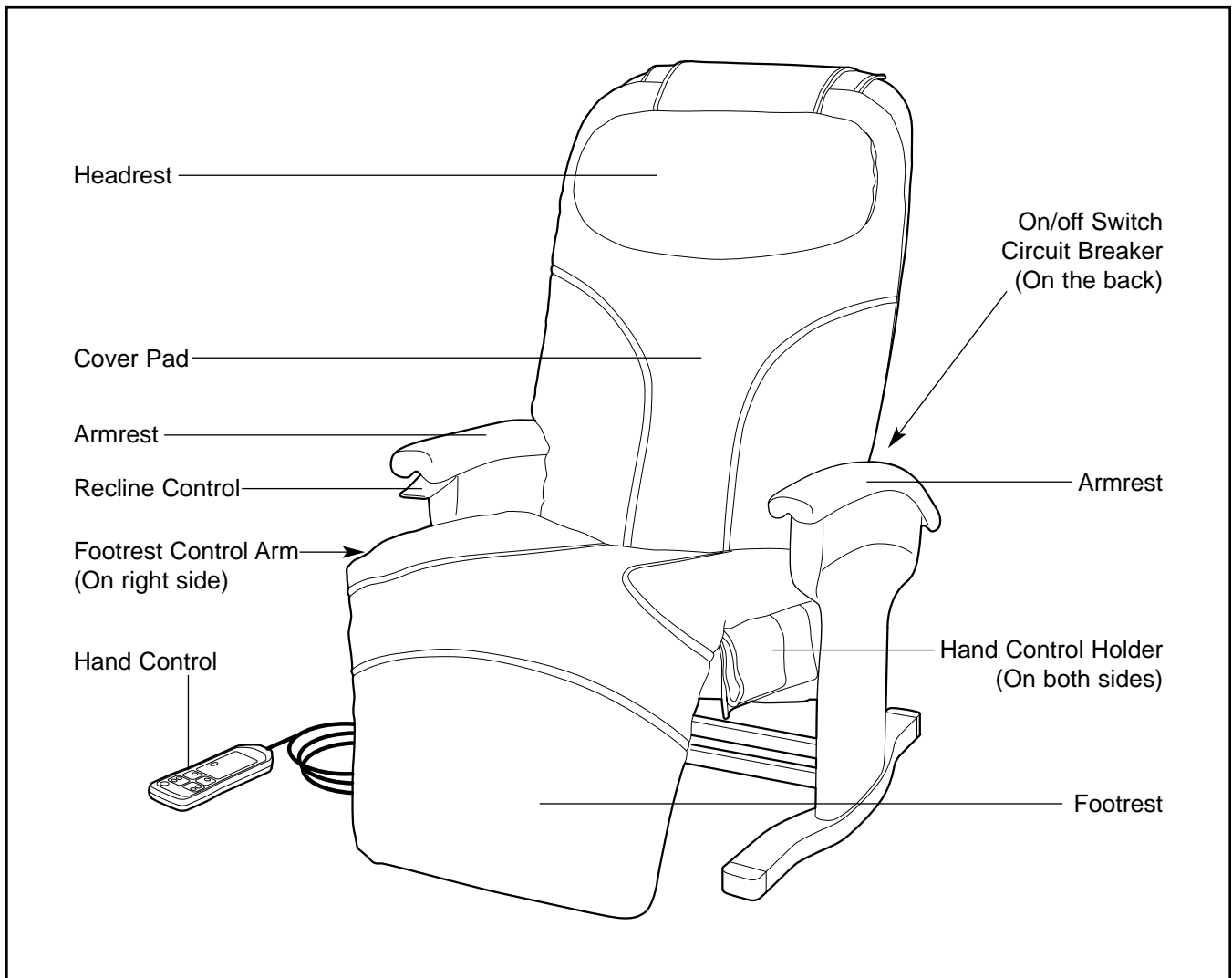

Assembly

Place all parts of the massage chair in a cleared area and remove the packing materials. Do not dispose of the packing materials until the massage chair is fully assembled. **Assembly requires only the included allen wrench.**

1. Feed the Recline Shock (20) and the attached cable between the tubes on the Base (1) as shown.

Refer to the inset drawing. Remove the rubber bands from the Bracket Screws (32) in the Base (1). Make sure that the Arm Brackets (31) inside the tubes are pressed against the indicated sides of the tubes.

Align the posts on the Right Armrest (5) with the tubes on the Base (1). Slide the Right Armrest onto the Base. **Make sure that the posts are inside of the tubes on the Base. In addition, make sure that the cable is between the posts. Note: You may need to flex the posts away from the Right Side Shield (7) to slide the Right Armrest past the Bracket Screws (32).**

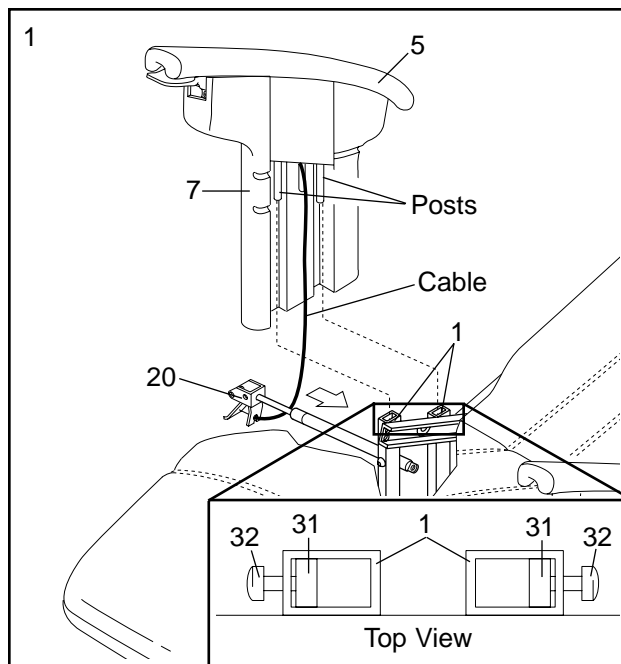

2. Tip the chair onto its right side. Remove the shipping bracket from the Seat Frame (2) and the Back Frame (4) by removing the Cotter Pins (26) and the Hairpin Cotters (27). **Save the Cotter Pins and the Hairpin Cotters; you will need them for step 3.**

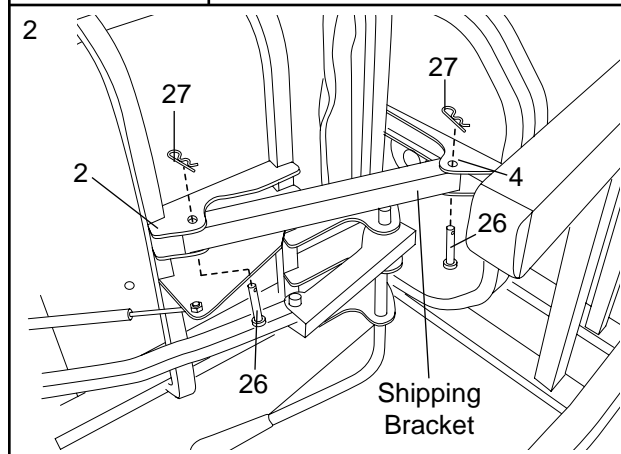

3. Attach the indicated end of the Recline Shock (20) to the Back Frame (4) with a Cotter Pin (26) and a Hairpin Cotter (27).

Attach the other end of the Recline Shock (20) to the Seat Frame (2) with a Cotter Pin (26) and a Hairpin Cotter (27). **Make sure that the cable is under the Recline Shock, as shown in the drawing. Note: You may need to raise the Back Frame (4) to the upright position in order to attach the Recline Shock.**

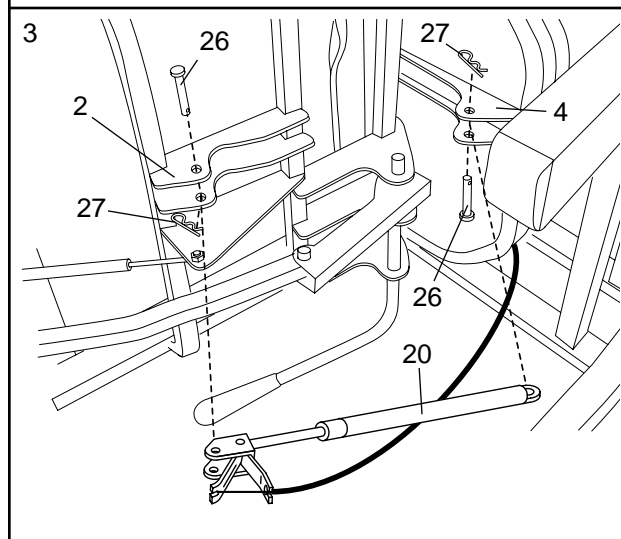

Tip the chair back onto its base.

4. Refer to the inset drawing. Remove the rubber bands from the Bracket Screws (32) in the left side of the Base (1). Make sure that the Arm Brackets (31) inside the tubes are pressed against the indicated sides of the tubes.

Align the posts on the Left Armrest (6) with the tubes on the Base (1). Slide the Left Armrest onto the Base. **Make sure that the posts are inside the tubes on the Base. Note: You may need to flex the posts away from the Left Side Shield (8) to slide the Left Armrest past the Bracket Screws (32).**

Attach the Pillow (13) to the fastener strip.

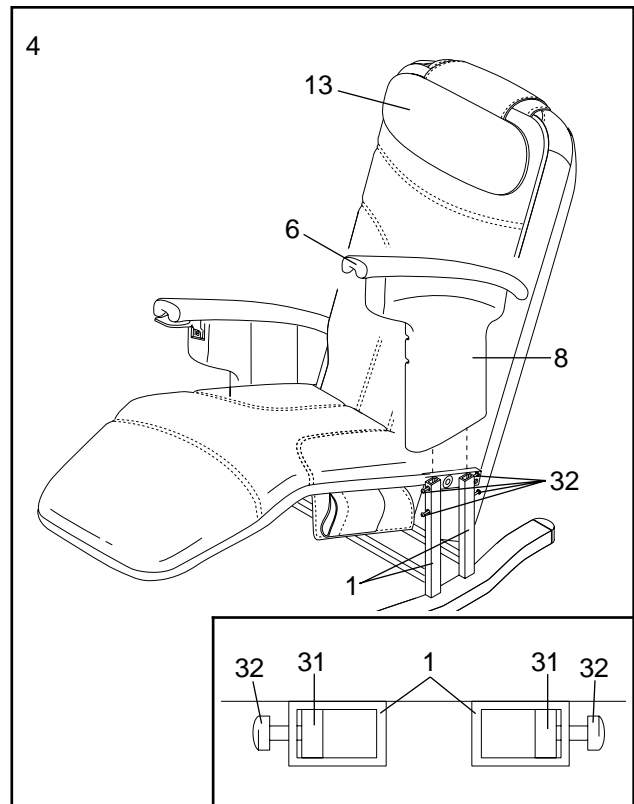

5. Raise the footrest by pulling on the Footrest Control Arm (23), shown in the inset drawing. Attach the lower end of the Right Side Shield (7) to the right side of the Base (1) with two Arm Cover Screws (35) and two M6 Washers (95).

Attach the lower end of the Left Side Shield (not shown) to the left side of the Base (1) in the same way.

Using the included allen wrench, tighten the four Bracket Screws (32) in the right side of the Base (1).

Tighten the four Bracket Screws (not shown) in the left side of the Base (1).

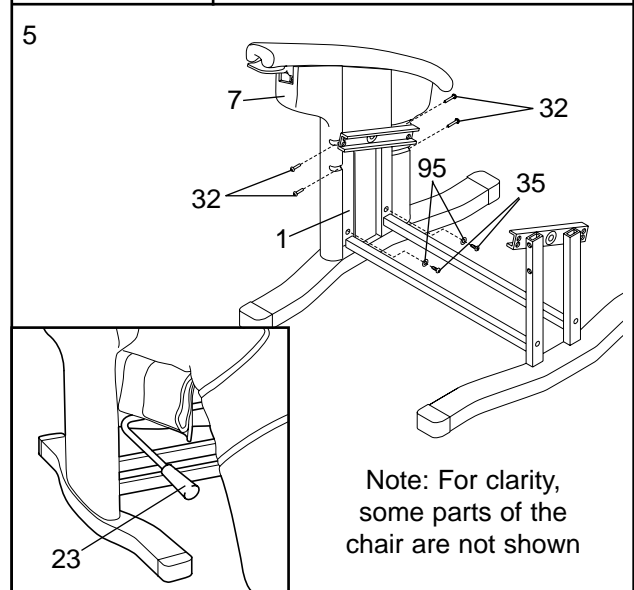

6. Plug the cord from the Hand Control (22) into the socket on the back of the massage chair. **Make sure to align the indicated tabs.**

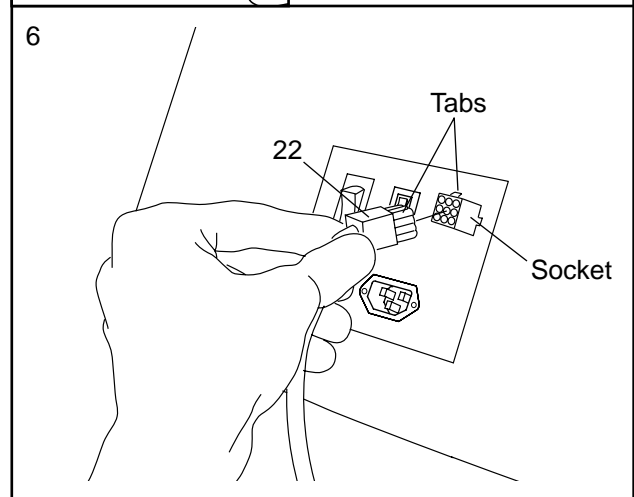

How to Operate the Massage Chair

HOW TO PLUG IN THE POWER CORD

⚠ DANGER: Improper connection of the equipment-earthing conductor can result in an increased risk of electric shock. Check with a qualified electrician or serviceman if you are in doubt as to whether the product is properly grounded. Do not modify the plug provided with the product—if it will not fit the outlet, have a proper outlet installed by a qualified electrician.

This product must be earthed. If it should malfunction or break down, earthing provides a path of least resistance for electric current to reduce the risk of electric shock. Use this product with an equipment-earthing conductor and an earthing plug. Plug one end of the cord into the massage chair. **Plug the power cord into an appropriate outlet that is properly installed and earthed in accordance with all local codes and ordinances.**

Use only a power cord type H05VV-F with a conductor of at least 1mm², with a country recognised plug and an appliance coupler.

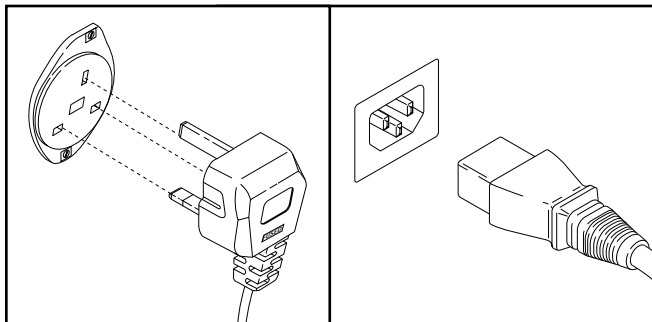

HOW TO TURN ON THE POWER

Make sure the power switch on the back of the chair is in the “on” position.

Next, press the power button on the hand control; an indicator will light. Note: If there is a thin sheet of plastic on the face of the hand control, remove it.

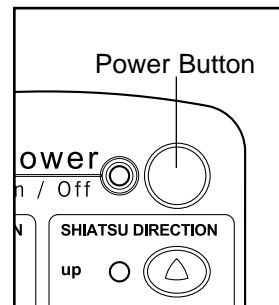

HOW TO TURN OFF THE POWER

To turn off the power, press the power button on the hand control. The power indicator will darken. Return the power switch on the back of the chair to the “off” position.

DESCRIPTION OF THE HAND CONTROL

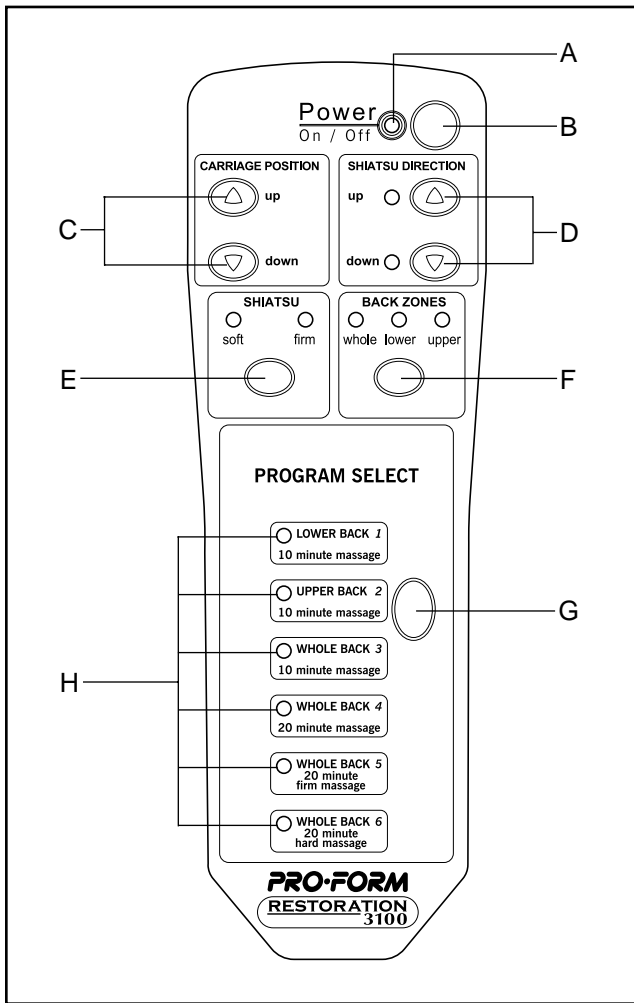

- A. Power Indicator—Lights when the power is on.
- B. Power Button—Turns the power on and off.
- C. Carriage Position Buttons—Manually move the massage mechanism up and down to target specific areas of the back for a localised massage.
- D. Shiatsu Direction Buttons and Indicators—These buttons control the rotational direction of the massage when the Carriage Position Buttons (C) are used.
- E. Shiatsu Button and Soft and Firm Indicators—This button selects either a soft or firm massage when you are using the three massage zones.
- F. Back Zones Button and Whole, Lower, and Upper Indicators—The Back Zones button selects the three massage zones. When the “Whole” indicator

is lit, the massage mechanism will move up and down, massaging your entire back. When the “Lower” indicator is lit, the massage mechanism will move up and down, massaging your lower back. When the “Upper” indicator is lit, the massage mechanism will move up and down, massaging your upper back.

- G. Program Button—This button selects the six programs.
- H. Program Indicators—These will light to show which program is selected.

FEATURES OF THE MASSAGE CHAIR

The convenient hand control lets you customise the type of massage you get each time you use the massage chair. In the manual mode, you can choose any combination of upper-back, lower-back and whole-back massage action. If desired, you can also position the massage carriage to target a specific area of your back for a specialised massage.

The control also offers six massage programs: 10-Minute Lower Back, 10-Minute Upper Back, 10-Minute Whole Back, 20-Minute Whole Back, 20-Minute Whole Back—Firm Massage and 20-Minute Whole Back—Hard Massage.

HOW TO USE THE MANUAL MODE

When the power is turned on, the hand control will be in the manual mode. The power indicator should be the only indicator that is lit.

1. Use the Carriage Position buttons to move the massage carriage to the location you wish to massage.
2. Use the Shiatsu Direction buttons to begin massaging your back. You may want to try alternating the shiatsu directions during your massage.
3. If you like, you can use the Carriage Position buttons to move the carriage up and down during the massage.

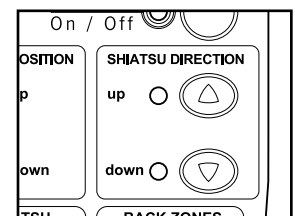
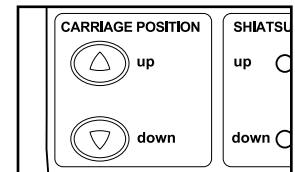

HOW TO USE THE MESSAGE ZONES

The massage chair also features three massage zones: upper back, lower back and whole back. The massage zones are controlled with the Back Zones button.

1. Press the button once.

The indicator above “whole” will light, activating the whole massage zone. Press the button again and the indicator above “lower” will light, activating the lower massage zone. Press the button again and the indicator above “upper” will light, activating the upper massage zone. Pressing the button again will end the massage. Press the button once more to reactivate the “whole” massage zone.

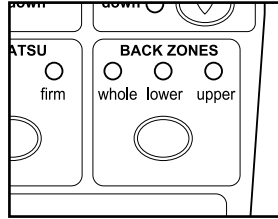

2. While you are using the massage zones, you can modify the intensity of the massage by using the Shiatsu button to select a soft or firm massage.

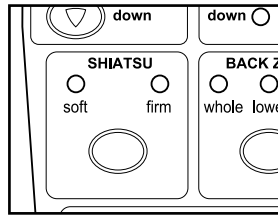

Note: The massage action will automatically stop if no buttons on the hand control are pressed for twenty minutes. This applies to both the manual mode and the message zones. To restart the massage action, simply press the power button on the hand control and select the desired massage option.

HOW TO USE THE MESSAGE PROGRAMS

In addition to the manual mode and message zones, the massage chair offers six massage programs.

1. Press the Program button repeatedly to select the desired mode. A program indicator will light to show which program is selected. If the program you selected targets the lower back, the lower back zone indicator will

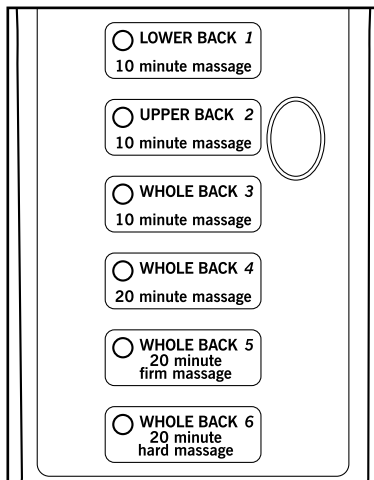

also light. If the program you selected targets the upper back, the upper back zone indicator will also light. If the program you selected targets the whole back, the whole back zone indicator will also light.

2. Once you have selected a program, sit back, relax and enjoy the massage. You can change to a different program at any time.

The message programs and their functions are:

LOWER BACK 1. This program offers a ten-minute lower back massage.

UPPER BACK 2. This program offers a ten-minute upper back massage.

WHOLE BACK 3. This program offers a ten-minute massage of your whole back.

WHOLE BACK 4. This program offers a twenty-minute massage of your whole back.

WHOLE BACK 5. This program offers a twenty-minute firm massage of your whole back.

WHOLE BACK 6. This program offers a twenty-minute hard massage of your whole back.

Note: If no buttons on the hand control are pressed while a program is running, the massage chair will shut off once the program is finished. To restart the massage action, simply press the power button on the hand control and select the desired massage option.

HOW TO USE THE RECLINE CONTROL

To recline the chair, simply pull up on the recline control on the right armrest. Lean back in the chair until you have reached the desired position. Release the recline control.

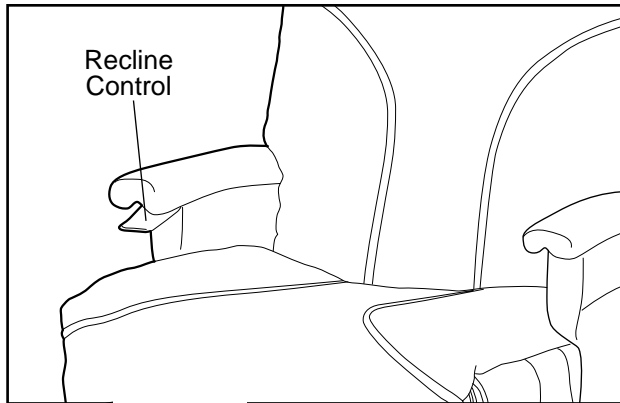

To return the chair to the upright position, sit up in the chair and pull up on the recline control. The chair back will return to the upright position.

HOW TO USE THE FOOTREST

To extend the footrest, pull back on the footrest control arm on the right side of the chair, until you feel the control arm lock into place. The footrest will extend.

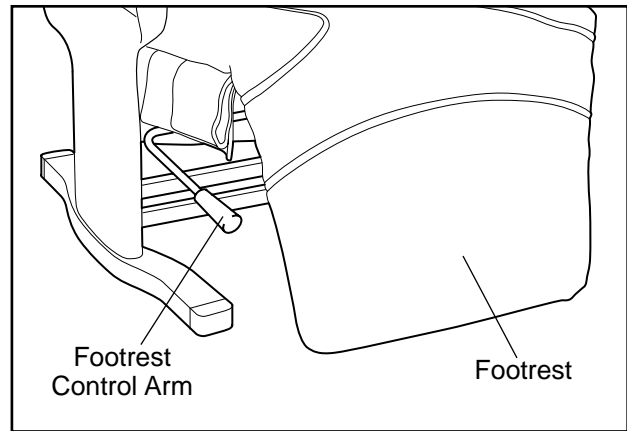

To lower the footrest, simply push the control arm forward.

Maintenance

Check the massage chair periodically to make sure that all parts are properly tightened.

If the hand control does not function properly, check the following things:

- Is the power cord plugged into a 240-volt outlet?
- Is the power switch on the back of the chair in the "ON" position?

- Is the hand control properly connected to the massage chair? (See assembly step 6 on page 6.)

The massage chair can be cleaned with a low-power hand-held vacuum or a dry cloth. **IMPORTANT: Never use water or solvents to clean the massage chair.**

Ordering Replacement Parts

If you encounter any difficulties with this product, or if you need to order replacement parts, write or call the ICON Fitness Lifestyle Ltd. office at:

ICON Fitness Lifestyle Ltd.
Greenwich House
223 North Street
Sheepscar
West Yorkshire

Tel: Country Code: 0345-089009
Fax: 0113-2411120

Please provide the following information when writing or calling:

- The MODEL NUMBER of the product (PERX31090)
- The NAME of the product (PROFORM RESTORATION 3100 massage chair)
- The SERIAL NUMBER of the product (see the front cover of this manual)
- The KEY NUMBER and DESCRIPTION of the desired part(s) (see the PART LIST and EXPLODED DRAWING in the centre of this manual).

PROFORM® is a registered trademark of ICON Health & Fitness, Inc.

**REMOVE THIS PART LIST/EXPLODED
DRAWING FROM THE MANUAL**

SAVE THIS PART LIST/EXPLODED DRAWING FOR FUTURE REFERENCE

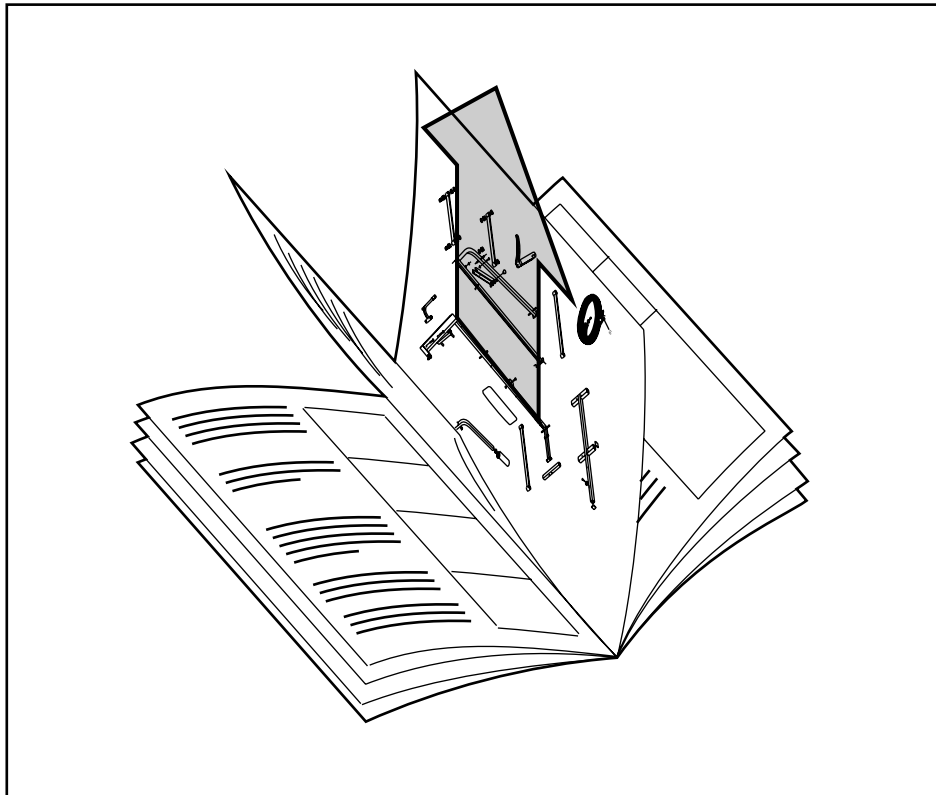

Part List—Model No. PERX31090

R0100A

Key No.	Qty.	Description	Key No.	Qty.	Description
1	1	Base	52	6	Roller Nut
2	1	Seat Frame	53	4	Spring Pin
3	1	Leg Frame	54	1	Circuit Board
4	1	Back Frame	55	4	Board Spacer
5	1	Right Armrest	56	4	Board Nut
6	1	Left Armrest	57	4	Board Screw
7	1	Right Side Shield	58	2	Flat-sided Washer
8	1	Left Side Shield	59	4	Brace Washer
9	1	Right Panel	60	4	Brace Nut
10	1	Left Panel	61	2	Brace Screw
11	1	Seat Support	62	6	Wire Tie
12	10	Support Hook	63	2	Limit Switch
13	1	Pillow	64	1	Four-wire Coil
14	1	Cover Pad	65	2	Rear Wheel Axle
15	1	Chair Back Cover	66	3	Black Jumper Wire
16	1	Cover	67	1	IEC Filter Socket
17	1	Back Brace	68	1	Power Switch
18	1	Back Cover	69	1	Circuit Breaker
19	2	Front Endcap	70	2	Wire Mount
20	1	Recline Shock	71	4	Bearing Screw
21	1	Shock Actuator	72	1	Sensor
22	1	Hand Control	73	6	Sensor Screw
23	1	Footrest Control Arm	74	6	Sensor Nut
24	1	Leg Link	75	1	Sensor Bracket
25	1	Link Arm	76	1	Motor
26	6	Cotter Pin	77	1	Fan
27	6	Hairpin Cotter	78	1	Drive Capacitor
28	1	Shock Nut	79	1	Belt
29	3	Set Screw	80	4	Star Washer
30	2	Seat Pin	81	4	Motor Washer
31	4	Arm Bracket	82	4	Motor Screw
32	10	Bracket Screw	83	1	Lift Assist Shock
33	4	Arm Screw	84	4	Endcap Screw
34	4	Arm Washer	85	2	Rear Endcap
35	4	Arm Cover Screw	86	2	Long Massage Spring
36	4	Pad Frame Screw	87	2	Seat Frame Endcap
37	4	Back Cover Screw	88	1	Sensor Wire
38	2	Straight Massage Arm	89	1	Shiatsu Capacitor
39	2	Rear Wheel	90	1	Cover Bracket
40	4	Short Massage Spacer	91	1	Upper Switch Cover Bracket
41	4	Long Massage Spacer	92	1	Lower Switch Cover Bracket
42	4	Massage Motor Nut	93	3	Tec Screw
43	1	Massage Motor	94	2	M8 Nut
44	2	Roll Pin	95	4	M6 Washer
45	2	Short Massage Spring	96	1	White Jumper Wire
46	1	Right Bent Massage Arm	97	1	Ground Wire
47	1	Left Bent Massage Arm	98	1	M3x14mm Screw
48	4	Massage Roller	99	1	M3 Star Washer
49	4	Massage Screw	100	1	M3 Nylon Nut
50	18	Roller Washer	101	2	#6 x 1/2" Screw
51	8	Roller Bolt	#	1	User's Manual

Note: “#” indicates a non-illustrated part. Specifications are subject to change without notice. To order replacement parts, see the back cover of this manual.

Exploded Drawing—Model No. PERX31090

R0100A

