

PRO-FORM[®]

600 ZLT

Model No. PETL69910.0

Serial No. _____

Write the serial number in the space above for reference.

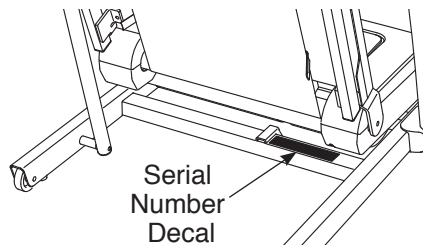

USER'S MANUAL

CUSTOMER CARE

UNITED KINGDOM

Call: 08457 089 009

From Ireland: 053 92 36102

Website: www.iconsupport.eu

E-mail: csuk@iconeurope.com

Write:

ICON Health & Fitness, Ltd.

c/o HI Group PLC

Express Way

CASTLEFORD

WF10 5QJ

UNITED KINGDOM

AUSTRALIA

Call: 1800 993 770

E-mail: australiacc@iconfitness.com

Write:

ICON Health & Fitness

PO Box 635

WINSTON HILLS NSW 2153

AUSTRALIA



⚠ CAUTION

Read all precautions and instructions in this manual before using this equipment. Keep this manual for future reference.

www.iconeurope.com

TABLE OF CONTENTS

WARNING DECAL PLACEMENT 2

IMPORTANT PRECAUTIONS 3

BEFORE YOU BEGIN 5

ASSEMBLY 6

OPERATION AND ADJUSTMENT 15

HOW TO FOLD AND MOVE THE TREADMILL 24

TROUBLESHOOTING 25

EXERCISE GUIDELINES 28

PART LIST 30

EXPLODED DRAWING 32

ORDERING REPLACEMENT PARTS Back Cover

RECYCLING INFORMATION Back Cover



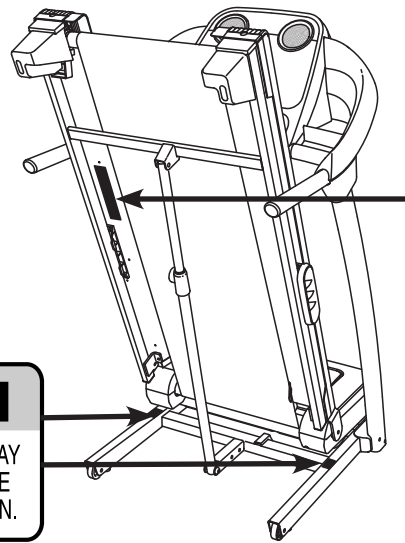

WARNING DECAL PLACEMENT

This drawing shows the locations of the warning decals. **If a decal is missing or illegible, call the telephone number on the front cover of this manual and request a free replacement decal. Apply the decal in the location shown. Note:** The decals may not be shown at actual size.



CAUTION
KEEP HANDS AND FEET AWAY FROM THIS AREA WHILE THE TREADMILL IS IN OPERATION.

▲WARNING:
Protect yourself and others from risk of serious injury. Read the user's manual and :

-  •Stand only on the side rails when starting or stopping treadmill.
- Change speed in small increments.
- Hold handrails to prevent falling, and always wear the safety clip while operating treadmill.
- Stop if you feel faint, dizzy, or short of breath.
- Fully engage storage latch before treadmill is moved or stored.
- Reduce incline to its lowest level before folding treadmill into storage position.
-  •Never allow children on or around treadmill.
- Remove key when not in use.
-  •Keep clothing, fingers, and hair away from moving belt.
- Never try to adjust or fix the belt while it is moving.
-  •Always wear athletic shoes while operating treadmill.

IMPORTANT PRECAUTIONS

⚠️WARNING: To reduce the risk of serious injury, read all important precautions and instructions in this manual and all warnings on your treadmill before using your treadmill. ICON assumes no responsibility for personal injury or property damage sustained by or through the use of this product.

1. Before beginning any exercise program, consult your physician. This is especially important for persons over age 35 or persons with pre-existing health problems.
2. It is the responsibility of the owner to ensure that all users of this treadmill are adequately informed of all warnings and precautions. Use the treadmill only as described.
3. Place the treadmill on a level surface, with at least 8 ft. (2.4 m) of clearance behind it and 2 ft. (0.6 m) on each side. Do not place the treadmill on any surface that blocks air openings. To protect the floor or carpet from damage, place a mat under the treadmill.
4. Keep the treadmill indoors, away from moisture and dust. Do not put the treadmill in a garage or covered patio, or near water.
5. Do not operate the treadmill where aerosol products are used or where oxygen is being administered.
6. Keep children under age 12 and pets away from the treadmill at all times.
7. The treadmill should be used only by persons weighing 300 lbs. (136 kg) or less.
8. Never allow more than one person on the treadmill at a time.
9. Wear appropriate exercise clothes while using the treadmill. Do not wear loose clothes that could become caught in the treadmill. Athletic support clothes are recommended for both men and women. *Always wear athletic shoes; never use the treadmill with bare feet, wearing only stockings, or in sandals.*
10. When connecting the power cord (see page 15), plug the power cord into an earthed circuit. No other appliance should be on the same circuit. When replacing the fuse in the power cord adapter, insert an ASTA-approved BS1362, 13-amp fuse into the fuse carrier.
11. If an extension cord is needed, use only a 3-conductor, 14-gauge (1 mm²) cord that is no longer than 5 ft. (1.5 m).
12. Keep the power cord away from heated surfaces.
13. Never move the walking belt while the power is turned off. Do not operate the treadmill if the power cord or plug is damaged, or if the treadmill is not working properly. (See TROUBLESHOOTING on page 25 if the treadmill is not working properly.)
14. Read, understand, and test the emergency stop procedure before using the treadmill (see HOW TO TURN ON THE POWER on page 17).
15. Never start the treadmill while you are standing on the walking belt. Always hold the handrails while using the treadmill.
16. The treadmill is capable of high speeds. Adjust the speed in small increments to avoid sudden jumps in speed.
17. The pulse sensor is not a medical device. Various factors, including the user's movement, may affect the accuracy of heart rate readings. The pulse sensor is intended only as an exercise aid in determining heart rate trends in general.

18. Never leave the treadmill unattended while it is running. Always remove the key, unplug the power cord, and press the power switch into the off position when the treadmill is not in use. (See the drawing on page 5 for the location of the power switch.)
19. Do not attempt to raise, lower, or move the treadmill until it is properly assembled. (See ASSEMBLY on page 6, and HOW TO FOLD AND MOVE THE TREADMILL on page 24.) You must be able to safely lift 45 lbs. (20 kg) to raise, lower, or move the treadmill.
20. When folding or moving the treadmill, make sure that the storage latch is holding the frame securely in the storage position.
21. Never insert any object into any opening on the treadmill.
22. Inspect and properly tighten all parts of the treadmill regularly.
23. **DANGER:** Always unplug the power cord immediately after use, before cleaning the treadmill, and before performing the maintenance and adjustment procedures described in this manual. Never remove the motor hood unless instructed to do so by an authorized service representative. Servicing other than the procedures in this manual should be performed by an authorized service representative only.
24. This treadmill is intended for in-home use only. Do not use this treadmill in a commercial, rental, or institutional setting.
25. Over exercising may result in serious injury or death. If you feel faint or if you experience pain while exercising, stop immediately and cool down.

SAVE THESE INSTRUCTIONS

BEFORE YOU BEGIN

Thank you for selecting the new PROFORM® 600 ZLT treadmill. The 600 ZLT treadmill offers a selection of features designed to make your workouts at home more effective and enjoyable. And when you're not exercising, the treadmill can be folded up, requiring less than half the floor space of other treadmills.

For your benefit, read this manual carefully before using the treadmill. If you have questions after

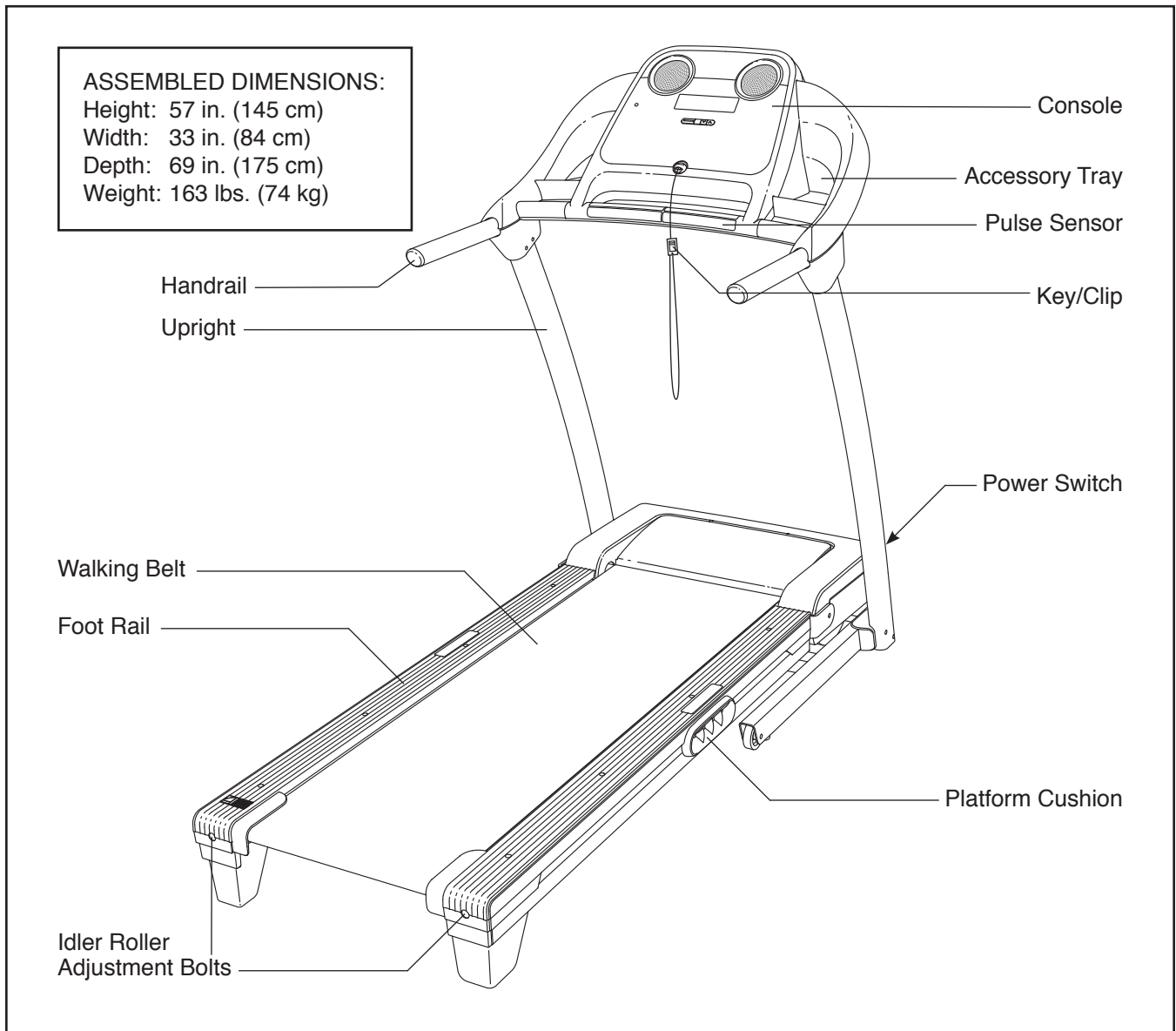

reading this manual, please see the front cover of this manual. To help us assist you, note the product model number and serial number before contacting us. The model number and the location of the serial number decal are shown on the front cover of this manual.

Before reading further, please review the drawing below and familiarize yourself with the labeled parts.

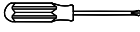

ASSEMBLY

Assembly requires two persons. Set the treadmill in a cleared area and remove all packing materials. **Do not dispose of the packing materials until assembly is completed.** Note: The underside of the treadmill walking belt is coated with high-performance lubricant. During shipping, some lubricant may be transferred to the top of the walking belt or the shipping carton. This is normal and does not affect treadmill performance. If there is lubricant on top of the walking belt, simply wipe off the lubricant with a soft cloth and a mild, non-abrasive cleaner.

Assembly requires the included hex keys  and your own Phillips screwdriver , adjustable wrench , and scissors .

Use the drawings below to identify the assembly hardware. The number in parentheses below each drawing is the key number of the part, from the PART LIST near the end of this manual. The number after the parentheses is the quantity needed for assembly. **Note: If a part is not in the hardware kit, check to see if it is preattached to one of the parts to be assembled. To avoid damaging parts, do not use power tools for assembly. Extra hardware may be included.**

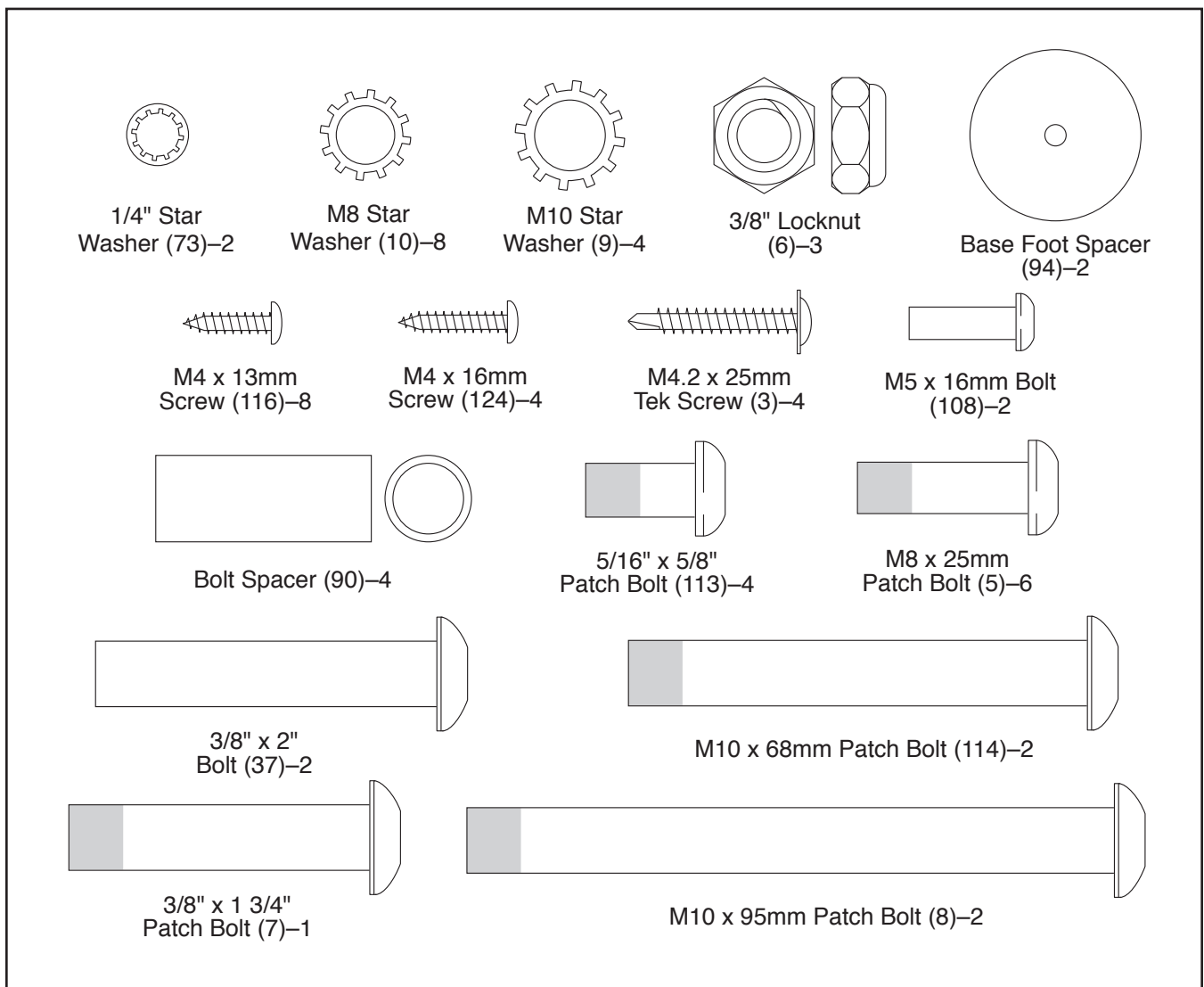

1. **Make sure that the power cord is unplugged.**

Remove the M10 Nut (19), the M10 x 50mm Bolt (31), and the shipping bracket (A) from the Base (95). Remove the shipping bracket from the other side of the treadmill. Discard the shipping brackets. **Save the Nuts and the Bolts for steps 3 and 6.**

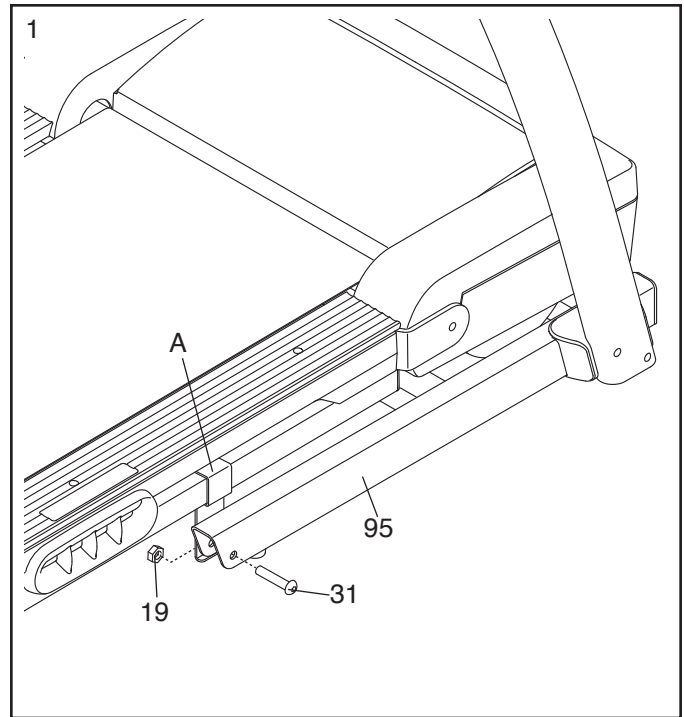

2. With the help of a second person, carefully tip the treadmill onto its left side. Partially fold the Frame (56) so that the treadmill is more stable; **do not fully fold the Frame yet.**

Cut the shipping tie securing the Upright Wire (88) to the Base (95). Next, locate a plastic tie in the indicated hole in the Base, and use the tie to pull the Upright Wire out of the hole.

Attach two Base Feet (92) to the Base (95) in the locations shown with two M4.2 x 25mm Tek Screws (3) and two Base Foot Spacers (94).

Attach the other two Base Feet (92) with only two M4.2 x 25mm Tek Screws (3).

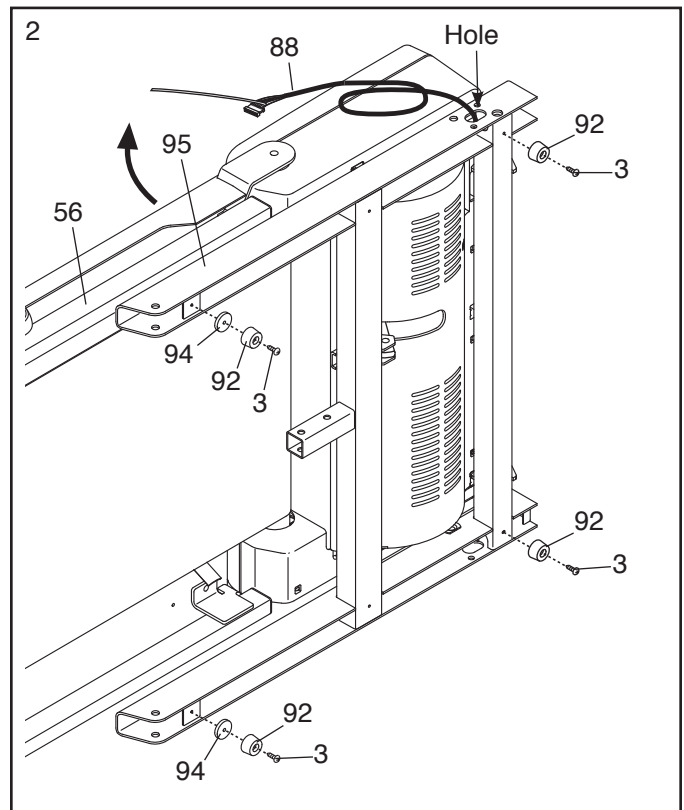

3. Attach a Wheel (97) with the M10 Nut (19), and the M10 x 50mm Bolt (31) that you removed in step 1. **Do not overtighten the Nut; the Wheel must turn freely.**

Press a Base Cap (87) into the Base (95).

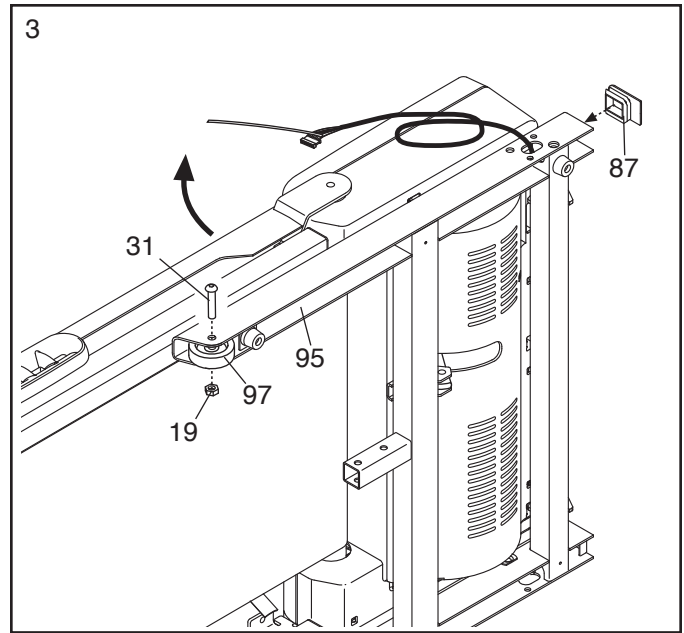

4. Identify the Right Upright (89) and the Right Upright Spacer (91), which are marked with "Right" stickers.

Insert the Upright Wire (88) through the Right Upright Spacer (91) as shown. Then, set the Right Upright Spacer on the Base (95).

With the help of a second person, hold the Right Upright (89) near the Base (95). **See the inset drawing.** Tie the long tie in the Right Upright securely around the end of the Upright Wire (88). Then, pull the other end of the long tie until the Upright Wire is routed through the Right Upright.

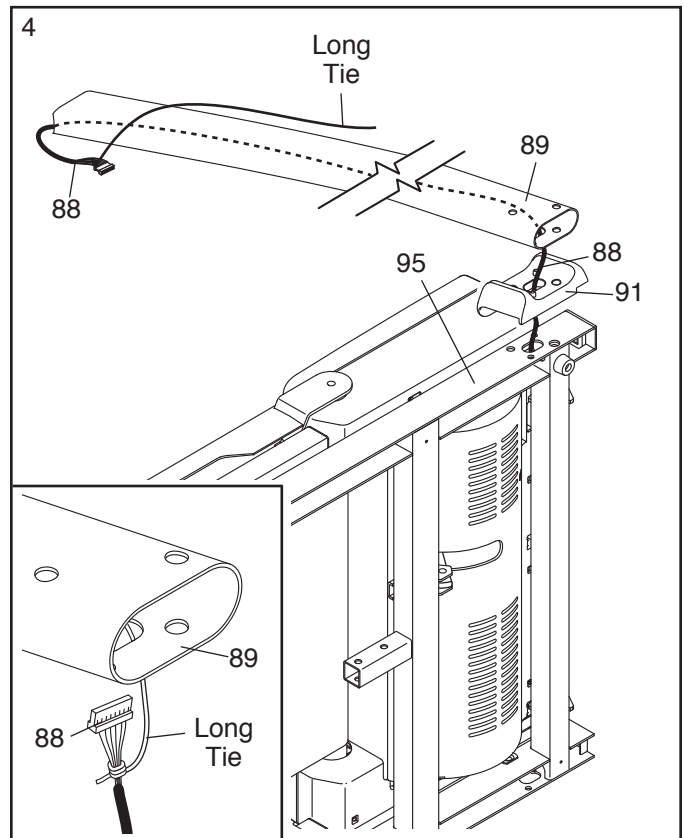

5. Hold a Bolt Spacer (90) inside the lower end of the Right Upright (89). Insert an M10 x 95mm Patch Bolt (8) with an M10 Star Washer (9) into the Right Upright and the Bolt Spacer. **Repeat this step with a second Bolt Spacer (90), an M10 x 68mm Patch Bolt (114), and an M10 Star Washer (9).**

Hold the Right Upright (89) against the Right Upright Spacer (91). **Be careful not to pinch the Upright Wire (88).** Tighten the M10 x 95mm Patch Bolt (8) and the M10 x 68mm Patch Bolt (114) until the heads of the Patch Bolts touch the Right Upright; **do not fully tighten the Patch Bolts yet.**

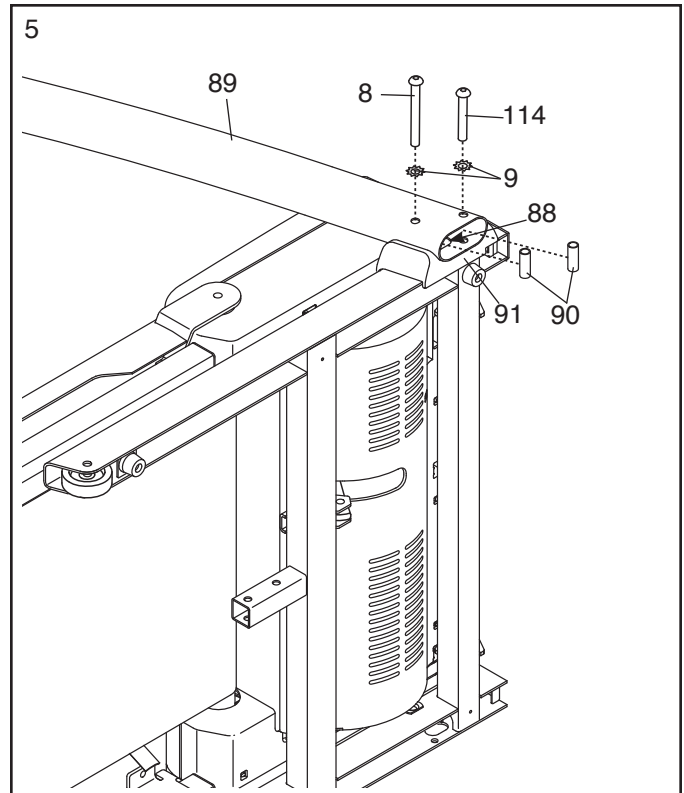

6. With the help of a second person, carefully tip the treadmill onto its right side. Partially fold the Frame (56) so that the treadmill is more stable; **do not fully fold the Frame yet.**

Attach a Wheel (97) with the M10 Nut (19), and the M10 x 50mm Bolt (31) that you removed in step 1. **Do not overtighten the Nut; the Wheel must turn freely.**

Press a Base Cap (87) into the Base (95).

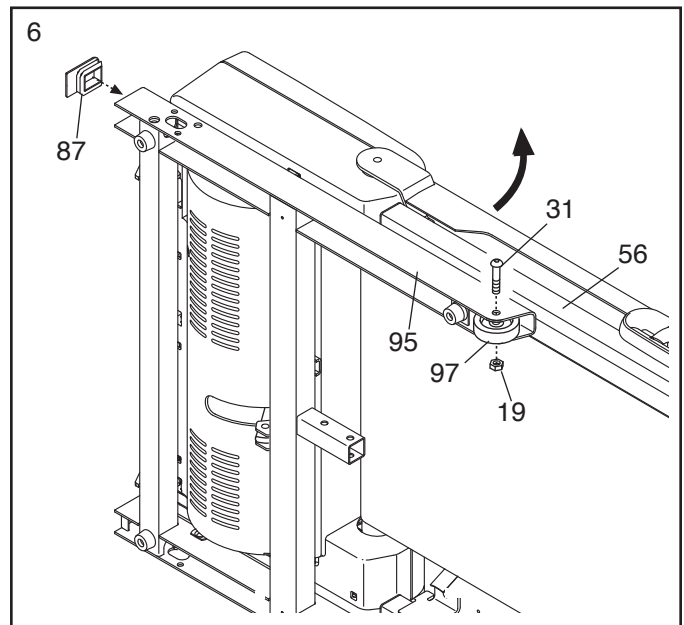

7. With the help of a second person, hold a Bolt Spacer (90) inside the lower end of the Left Upright (85). Insert an M10 x 95mm Patch Bolt (8) with an M10 Star Washer (9) into the Left Upright and the Bolt Spacer. **Repeat this step with a second Bolt Spacer (90), an M10 x 68mm Patch Bolt (114), and an M10 Star Washer (9).**

Hold the Left Upright Spacer (86) and the Left Upright (85) against the Base (95). Tighten the M10 x 95mm Patch Bolt (8) and the M10 x 68mm Patch Bolt (114) until the heads of the Patch Bolts touch the Left Upright; **do not fully tighten the Patch Bolts yet.**

With the help of a second person, tip the treadmill so that the Base (95) is flat on the floor.

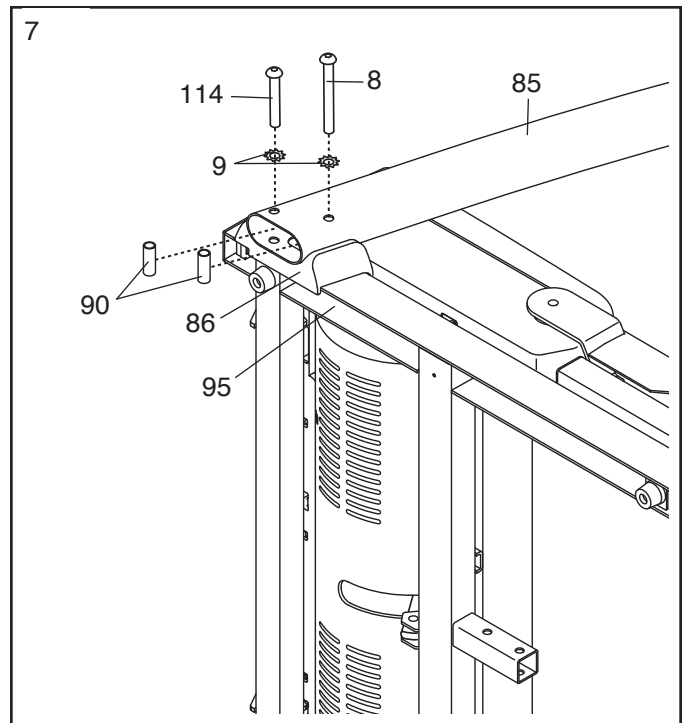

8. Identify the Left and Right Upright Covers (109, 110) which are marked with "Left" and "Right" stickers. Slide the Left Upright Cover onto the Left Upright (85) as shown. Slide the Right Upright Cover onto the Right Upright (89) as shown.

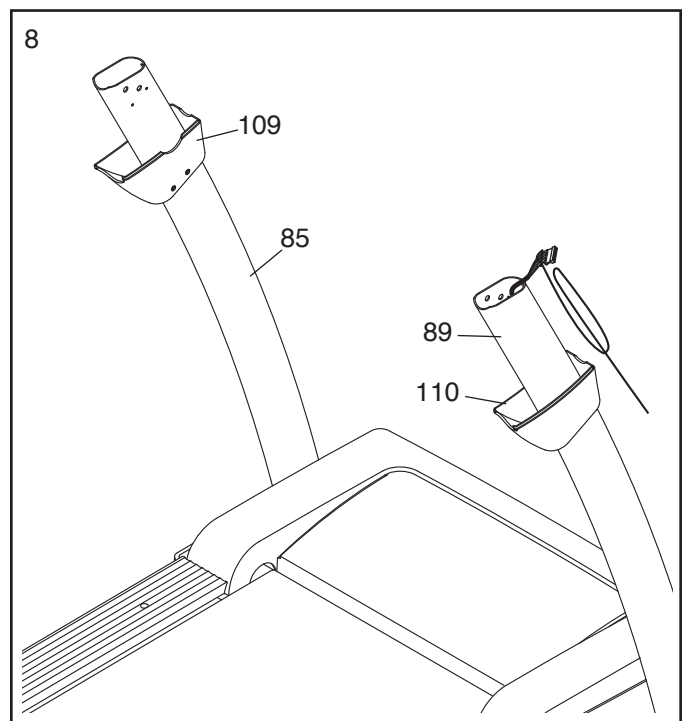

9. Set the console assembly face down on a soft surface to avoid scratching the console.

Loosen the four #8 x 1" Screws (107). Carefully pivot the Console Frame (111) to the position shown. **Do not pivot the Console Frame too far or you will break the ground wire.**

Identify the Left and Right Accessory Trays (104, 106). Attach the Accessory Trays to the console assembly with eight M4 x 13mm Screws (116).

Carefully pivot the Console Frame (111) back down to the console assembly.

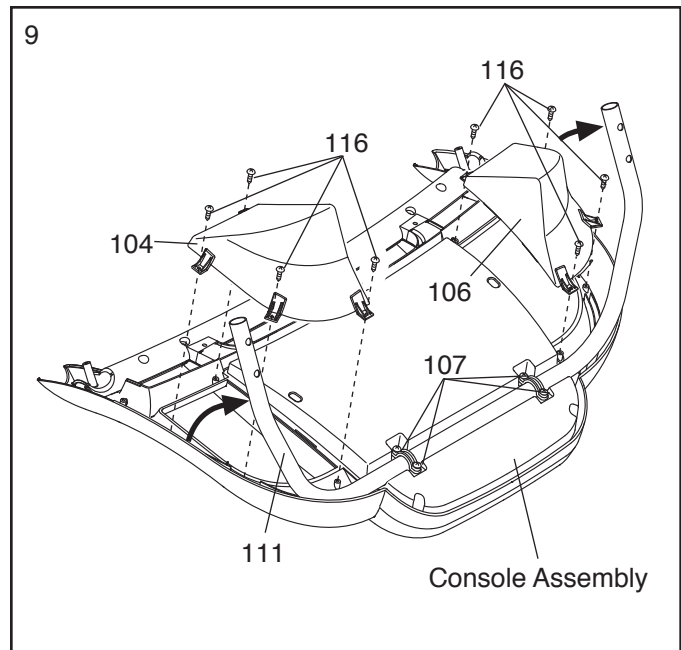

10. Identify the Right Handrail (101) which is marked with a "Right" sticker. Remove the tie from the Right Handrail. If necessary, press the M8 Cage Nut (34) back into place.

Hold the Right Handrail (101) near the console assembly. Route the console wire around the side of the Right Handrail as shown, and through the slot in the Right Handrail.

If necessary, adjust the Console Frame (111) to align the holes in the Right Handrail (101) with the holes in the Console Frame.

Attach the Right Handrail (101) to the Console Frame (111) and the console assembly with two M8 x 25mm Patch Bolts (5), two M8 Star Washers (10), an M5 x 16mm Bolt (108), and a 1/4" Star Washer (73). **Make sure the console wire is not pinched. Start all three Bolts, and then tighten all of them.**

Attach the Left Handrail (not shown) as described above. **Note: There is not a wire on the left side.**

Tighten the #8 x 1" Screws (107). **Be careful not to overtighten the Screws.**

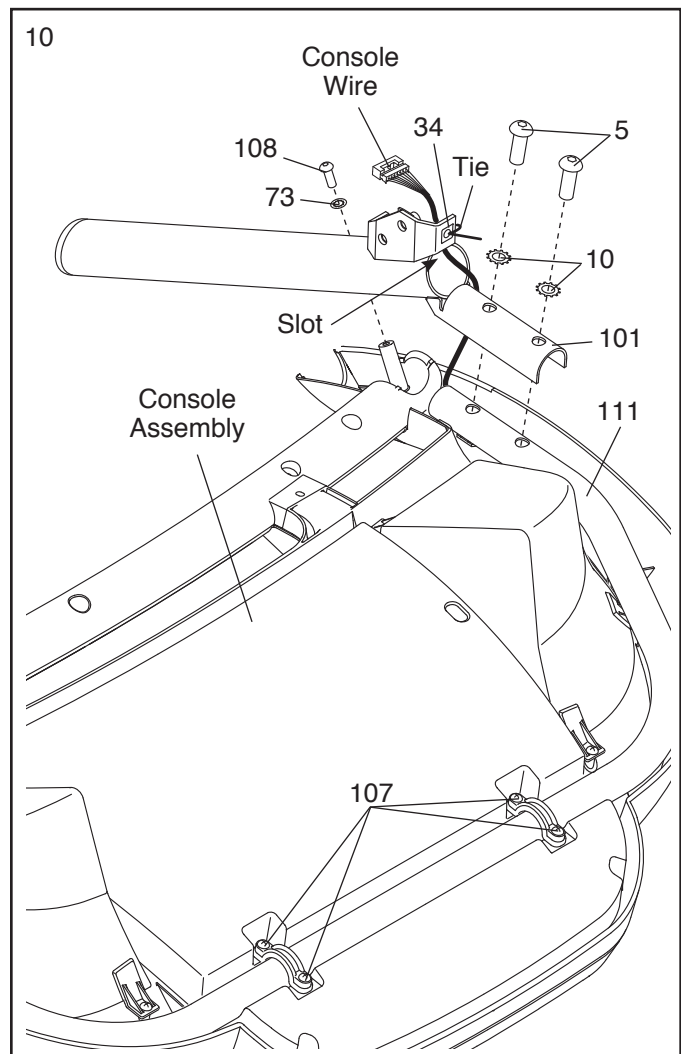

11. Have a second person hold the console assembly near the Right Upright (89).

Connect the Upright Wire (88) to the console wire. **See the inset drawing. The connectors should slide together easily and snap into place.** If they do not, turn one connector and try again. **IF YOU DO NOT CONNECT THE CONNECTORS PROPERLY, THE CONSOLE MAY BECOME DAMAGED WHEN YOU TURN ON THE POWER.** Remove the long tie from the Upright Wire. Then, insert the connectors into the Right Upright (89).

Set the console assembly on the Right Upright (89) and the Left Upright (not shown). **Make sure that no wires are pinched.**

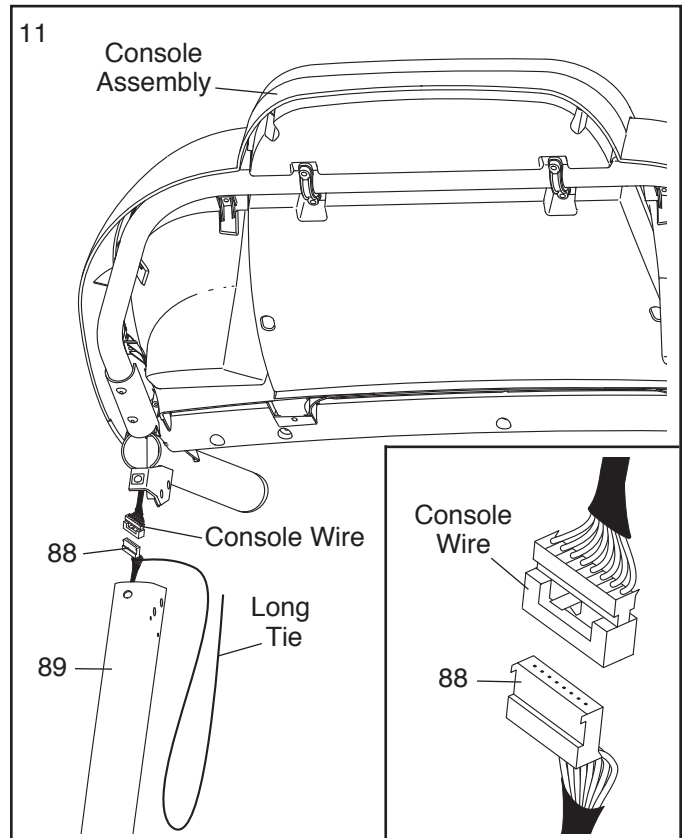

12. Start an M8 x 25mm Patch Bolt (5) and two 5/16" x 5/8" Patch Bolts (113) with two M8 Star Washers (10) into the Right Upright (89) and Right Handrail (101) as shown. **Do not tighten the Patch Bolts yet.**

Attach the Left Handrail (not shown) as described above. **Then, firmly tighten all six Patch Bolts.**

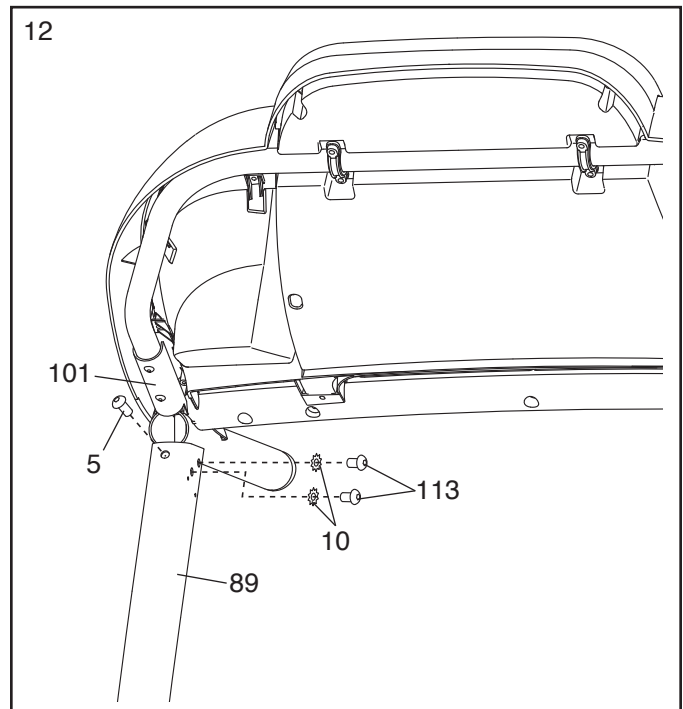

13. Slide the Right Upright Cover (110) up against the Right Handrail (101). Attach the Right Upright Cover with two M4 x 16mm Screws (124). **Be careful not to overtighten the Screws.**

Attach the Left Upright Cover (not shown) as described above.

See steps 5 and 7. Tighten the two M10 x 95mm Patch Bolts (8) and the two M10 x 68mm Patch Bolts (114).

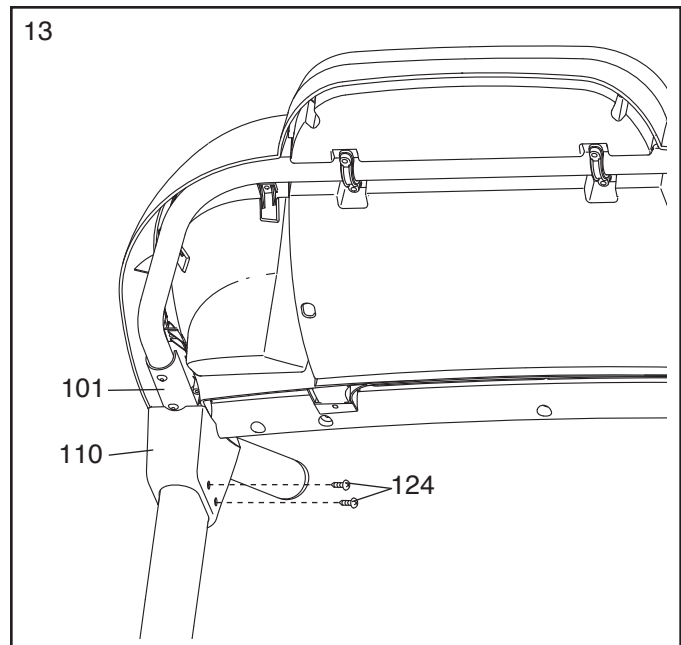

14. Raise the Frame (56) to the position shown. **Have a second person hold the Frame until this step is completed.**

Orient the Storage Latch (60) so that the large barrel and the latch knob are in the positions shown.

Attach the upper end of the Storage Latch (60) to the Frame (56) with a 3/8" x 1 3/4" Patch Bolt (7) and a 3/8" Locknut (6).

Attach the lower end of the Storage Latch (60) to the Base (95) with two 3/8" x 2" Bolts (37) and two 3/8" Locknuts (6). Note: It may be necessary to move the Frame (56) back and forth to align the Storage Latch with the Base.

Lower the Frame (56) (see HOW TO LOWER THE TREADMILL FOR USE on page 24).

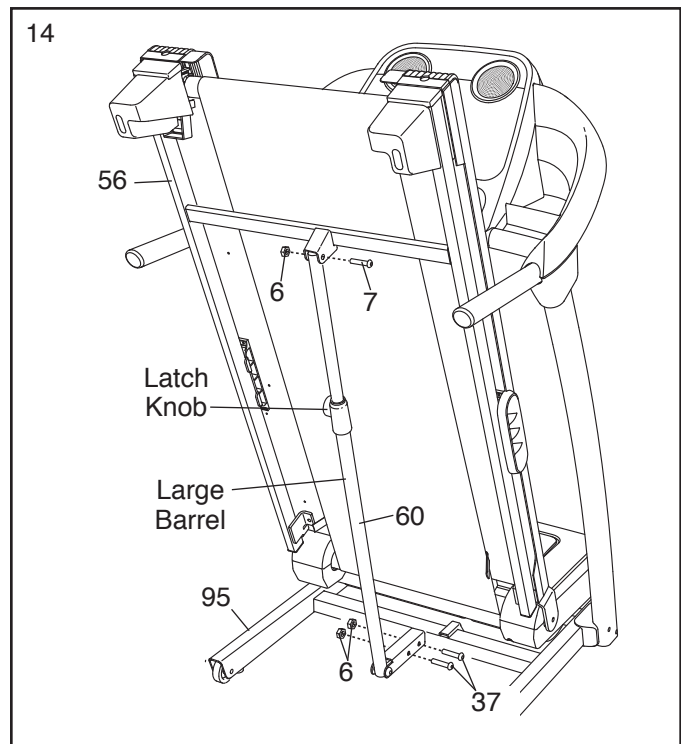

15. **Make sure that all parts are properly tightened before you use the treadmill.** If there are sheets of plastic on the treadmill decals, remove the plastic. To protect the floor or carpet, place a mat under the treadmill. Keep the included hex keys in a secure place; one of the hex keys is used to adjust the walking belt (see pages 26 and 27).

If you purchase the optional chest pulse sensor (see page 23), follow the steps below to install the receiver included with the chest pulse sensor.

1. **Make sure that the power cord is unplugged.** Remove the five M4 x 19mm Screws (35) and the two M4 x 45mm Screws (2) from the back of the console assembly.

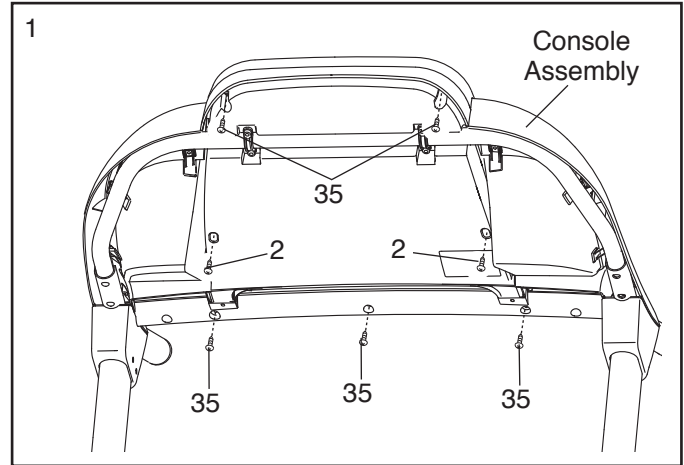

2. Carefully lift the console assembly off of the Console Base (103). Locate the Pulse Wire (A) on the console assembly.

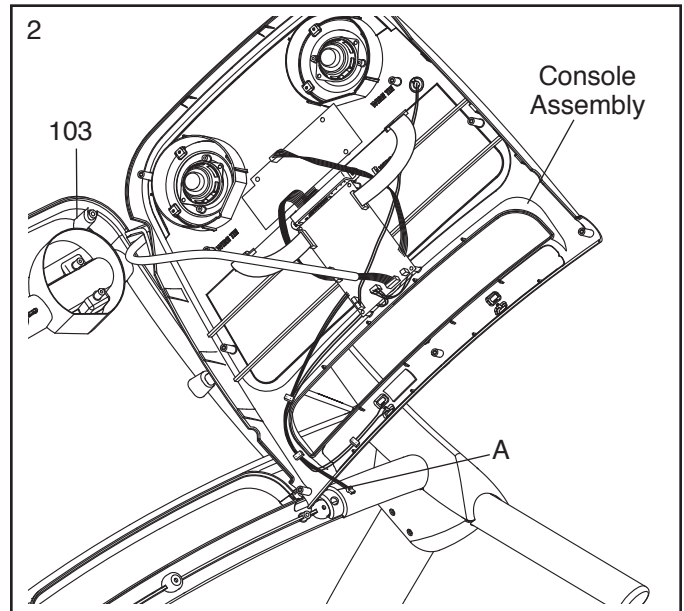

3. Connect the wire on the Receiver (B) to the Pulse Wire (A).

Peel the paper backing off the pad on the bottom of the Receiver (B) and off the console pad. **Next, hold the Receiver so that the antenna is oriented as shown.** Press the Receiver onto the console pad.

Remove the Wire Holder (C). Place the wire on the Receiver (B) between the two plastic pins and press the Wire Holder back on.

4. **See step 1.** Reattach the console assembly. **Make sure that no wires are pinched.** Discard the other wires included with the receiver.

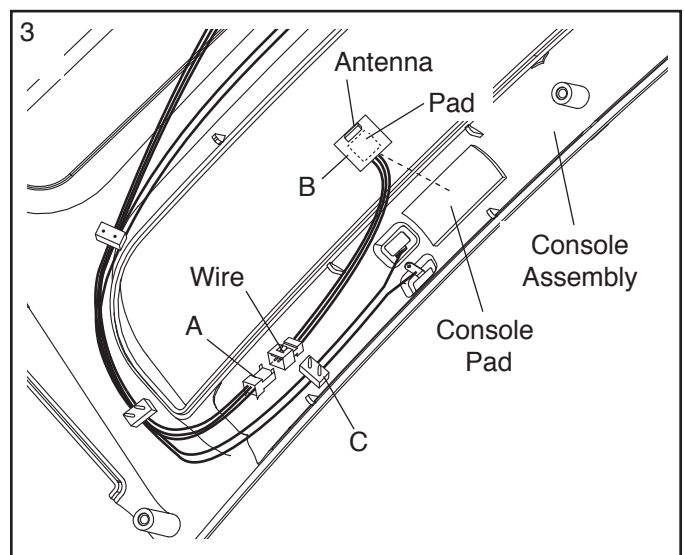

OPERATION AND ADJUSTMENT

THE PRE-LUBRICATED WALKING BELT

Your treadmill features a walking belt coated with high-performance lubricant. **IMPORTANT: Never apply silicone spray or other substances to the walking belt or the walking platform. Such substances will deteriorate the walking belt and cause excessive wear.**

HOW TO PLUG IN THE POWER CORD

This product must be earthed. If it should malfunction or break down, earthing provides a path of least resistance for electric current to reduce the risk of electric shock. This product is equipped with a power cord having an equipment-earthing conductor and an earthing plug. **IMPORTANT: If the power cord is damaged, it must be replaced with a manufacturer-recommended power cord.**

⚠ DANGER: Improper connection of the equipment-earthing conductor can result in an increased risk of electric shock. Check with a qualified electrician or serviceman if you are in doubt as to whether the product is properly earthed. Do not modify the plug provided with the product—if it will not fit the outlet, have a proper outlet installed by a qualified electrician.

Follow the steps below to plug in the power cord.

1. Plug the indicated end of the power cord into the socket on the treadmill.

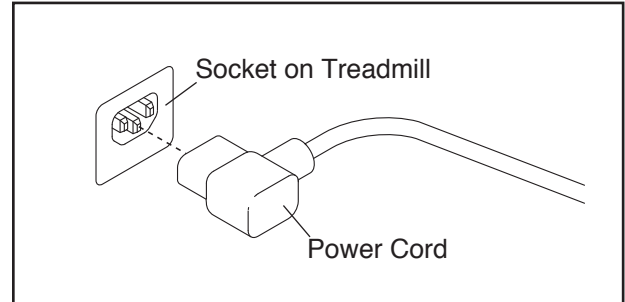

2. Plug the power cord into an appropriate outlet that is properly installed and earthed in accordance with all local codes and ordinances.

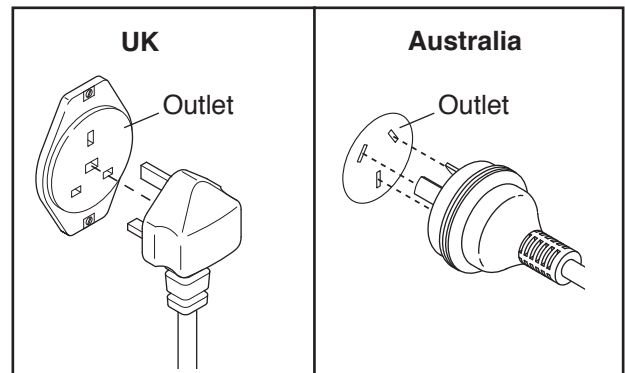

CONSOLE DIAGRAM

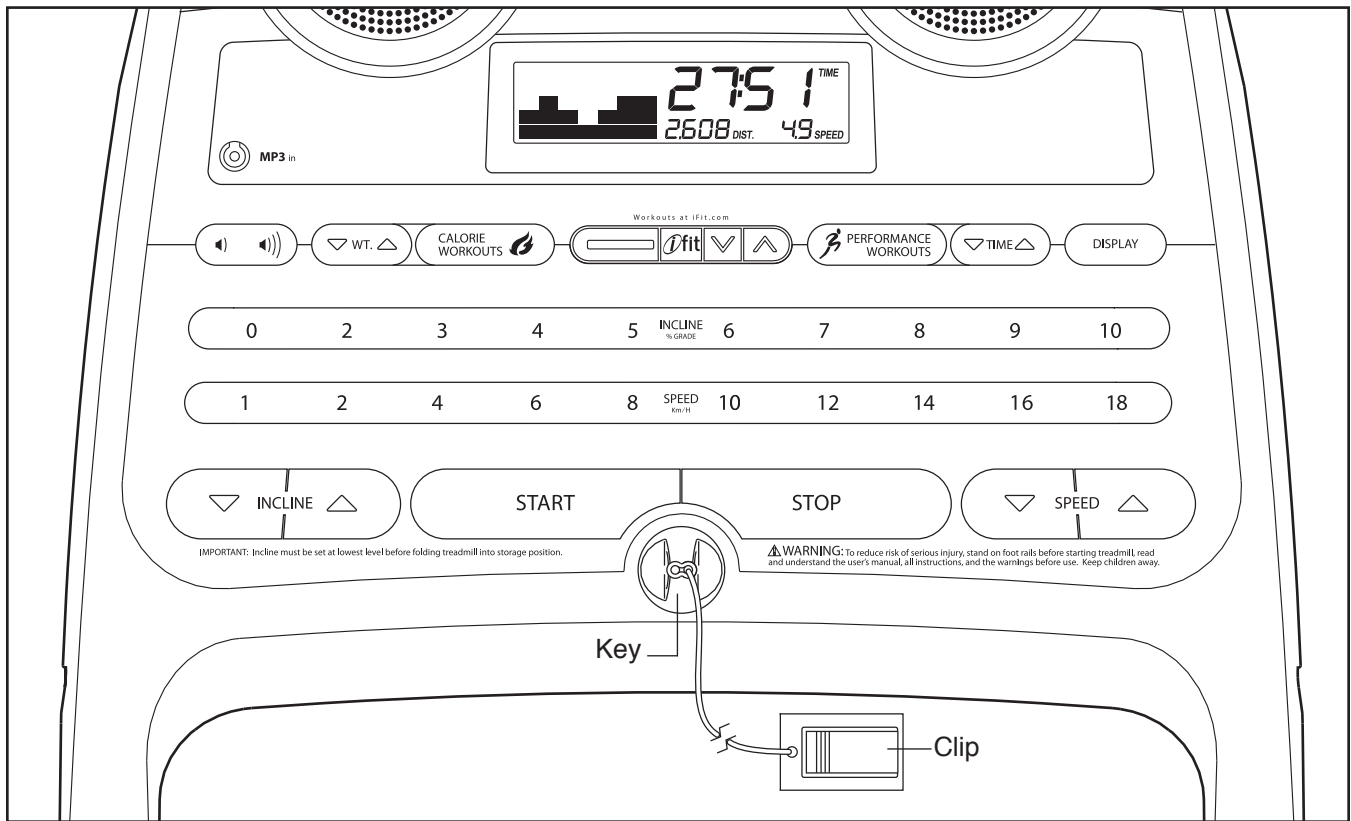

FEATURES OF THE CONSOLE

The treadmill console offers an impressive array of features designed to make your workouts more effective and enjoyable. When you use the manual mode, you can change the speed and incline of the treadmill with the touch of a button. As you exercise, the console will display instant exercise feedback. You can even measure your heart rate using the handgrip pulse sensor or the optional chest pulse sensor (see page 23).

In addition, the console features six calorie workouts and six performance workouts. Each workout automatically controls the speed and incline of the treadmill as it guides you through an effective exercise session.

The console also features the iFit interactive workout system. The iFit system accepts iFit cards with workouts that help you achieve specific fitness goals. For example, lose unwanted pounds with the 8-week Weight Loss workout. iFit workouts automatically control the treadmill. iFit cards are available separately. **To**

purchase iFit cards at any time, go to www.iFit.com or call the telephone number on the front cover of this manual.

You can even listen to your favorite workout music or audio books with the console's stereo sound system while you exercise.

To turn on the power, see page 17. To use the manual mode, see page 17. To use a calorie workout, see page 20. To use a performance workout, see page 21. To use an iFit workout, see page 22. To use the information mode, see page 23. To use the stereo sound system, see page 23.

Note: The console can display either English or metric measurements. To find out which unit of measurement is selected or to change the unit of measurement, see THE INFORMATION MODE on page 23. Note: For simplicity, all instructions in this section refer to metric measurements.

HOW TO TURN ON THE POWER

IMPORTANT: If the treadmill has been exposed to cold temperatures, allow it to warm to room temperature before turning on the power. If you do not do this, you may damage the console displays or other electrical components.

Plug in the power cord (see page 15). Next, locate the power switch on the treadmill frame near the power cord. Press the power switch into the reset position.

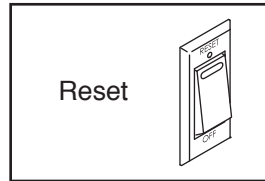

IMPORTANT: The console features a display demo mode, designed to be used if the treadmill is displayed in a store. If the displays light as soon as you plug in the power cord and press the power switch into the reset position, the demo mode is turned on. To turn off the demo mode, hold down the Stop button for a few seconds. If the displays remain lit, see THE INFORMATION MODE on page 23 to turn off the demo mode.

Next, stand on the foot rails of the treadmill. Find the clip attached to the key (see the drawing on page 16) and slide the clip onto the waistband of your clothes. Then, insert the key into the console. After a moment, the displays will light. **IMPORTANT:** In an emergency, the key can be pulled from the console, causing the walking belt to slow to a stop. Test the clip by carefully taking a few steps backward; if the key is not pulled from the console, adjust the position of the clip.

IMPORTANT: If there are sheets of plastic on the console, remove the plastic. To prevent damage to the walking platform, wear clean athletic shoes while using the treadmill. The first time you use the treadmill, observe the alignment of the walking belt, and center the walking belt if necessary (see page 27).

HOW TO USE THE MANUAL MODE

1. Insert the key into the console.

See HOW TO TURN ON THE POWER at the left.

2. Select the manual mode.

When the key is inserted, the manual mode will be selected. If a preset workout has been selected, remove the key and then reinsert it.

3. Enter your weight if desired.

For the most accurate calorie count, enter your weight into the console by pressing the Wt. increase and decrease buttons repeatedly. Note: Once you have entered your weight, your weight will be saved in memory.

4. Start the walking belt.

To start the walking belt, press the Start button, the Speed increase button, or one of the Speed buttons numbered 1 through 18.

If you press the Start button or the Speed increase button, the walking belt will begin to move at 2 Km/H. As you exercise, change the speed of the walking belt as desired by pressing the Speed increase and decrease buttons. Each time you press one of the buttons, the speed setting will change by 0.1 Km/H; if you hold down the button, the speed setting will change in increments of 0.5 Km/H. Note: After you press the button, it may take a moment for the walking belt to reach the selected speed setting.

If you press one of the numbered Speed buttons, the walking belt will gradually change speed until it reaches the selected speed setting.

To stop the walking belt, press the Stop button. The time will begin to flash in the display. To restart the walking belt, press the Start button or the Speed increase button.

5. Change the incline of the treadmill as desired.

To change the incline of the treadmill, press the Incline increase or decrease button or one of the numbered Incline buttons. Each time you press one of the buttons, the treadmill will gradually adjust to the selected incline setting.

6. Follow your progress with the displays.

The track—When the manual mode is selected, a track representing 400 meters will appear in the display. As you walk or run on the treadmill, the indicators around the track will appear in succession until the entire track appears. The track will then disappear and the indicators will again begin to appear in succession.



The lower left display—As you exercise, the lower left display can show the elapsed time and the distance that you have walked or run. The lower left display will also show the incline of the treadmill each time the incline level changes. Note: When a performance workout or an iFit workout is selected, the lower left display will show the time remaining in the workout instead of the elapsed time.

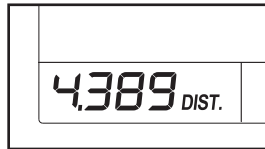

The lower right display—The lower right display can show the approximate number of calories that you have burned and the speed of the walking belt. The display also shows your heart rate when you use the handgrip pulse sensor (see step 7).

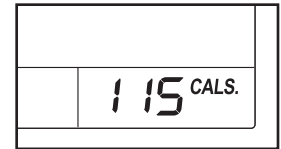

The upper display—The upper display can show the elapsed time, the distance that you have walked or run, the approximate number of calories that you have burned, or the speed of the walking belt. Press the Display button repeatedly until the upper display shows the information that you are most interested in viewing. Note: While information is shown in the upper display, the same information will not be shown in the lower displays.

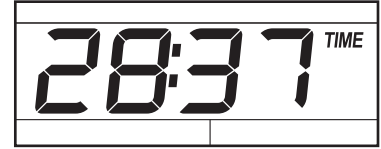

To reset the displays, press the Stop button, remove the key, and then reinsert the key.

7. Measure your heart rate if desired.

Note: If you use the handgrip pulse sensor and the optional chest pulse sensor at the same time, the console will not display your heart rate accurately. For information on the optional chest pulse sensor, see page 23.

Before using the handgrip pulse sensor, remove the sheets of plastic from the metal contacts on the pulse bar. In addition, make sure that your hands are clean.

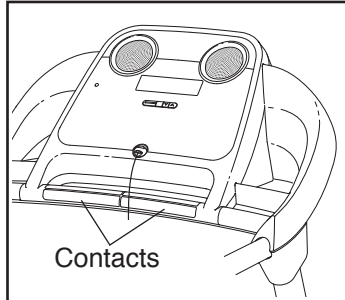

To measure your heart rate, **stand on the foot rails** and hold the pulse bar with your palms on the metal contacts for approximately ten seconds; **avoid moving your hands**. When your pulse is detected, a heart symbol in the lower right display

will flash each time your heart beats, one or two dashes will appear, and then your heart rate will be shown. **For the most accurate heart rate reading, continue to hold the contacts for about 15 seconds.**

8. When you are finished exercising, remove the key from the console.

Step onto the foot rails, press the Stop button, and **adjust the incline of the treadmill to the lowest setting. The incline must be at the lowest setting or you may damage the treadmill when you fold it to the storage position.** Next, remove the key from the console and put it in a secure place.

When you are finished using the treadmill, press the power switch into the off position and unplug the power cord. **IMPORTANT: If you do not do this, the treadmill's electrical components may wear prematurely.**

HOW TO USE A CALORIE WORKOUT

1. Insert the key into the console.

See HOW TO TURN ON THE POWER on page 17.

2. Select a calorie workout.

To select a calorie workout, press the Calorie Workouts button repeatedly until the desired workout appears in the display.

When you select a calorie workout, the maximum incline level of the workout will flash in the lower left display, the maximum speed setting will flash in the lower right display, and the approximate number of calories you will burn will flash in the upper display. In addition, a profile of the speed settings of the workout will scroll across the display.

3. Enter your weight if desired.

For the most accurate calorie count, enter your weight into the console by pressing the Wt. increase and decrease buttons repeatedly. Note: Once you have entered your weight, your weight will be saved in memory.

4. Start the workout.

Press the Start button or the Speed increase button to start the workout. A moment after you press the button, the treadmill will automatically adjust to the first speed and incline settings of the workout. Hold the handrails and begin walking.

Each workout is divided into one-minute segments. One speed setting and one incline setting are programmed for each segment. Note: The same speed setting and/or incline setting may be programmed for consecutive segments.

During the workout, the profile will show your progress. The flashing segment of the profile represents the current segment of the workout. The height of

the flashing segment indicates the speed setting for the current segment. At the end of each segment, a series of tones will sound. If a different speed and/or incline setting is programmed for the next segment, the speed and/or incline setting will flash in the display to alert you and the treadmill will automatically adjust to the new speed and/or incline setting.

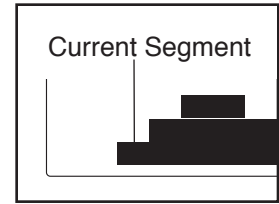

When the workout ends, the walking belt will slow to a stop.

If the speed or incline setting is too high or too low at any time during the workout, you can manually override the setting by pressing the Speed or Incline buttons; **however, when the next segment of the workout begins, the treadmill will automatically adjust to the speed and incline settings for the next segment.**

To stop the workout at any time, press the Stop button. To restart the workout, press the Start button or the Speed increase button. The walking belt will begin to move at 2 Km/H. When the next segment of the workout begins, the treadmill will automatically adjust to the speed and incline settings for the next segment.

5. Follow your progress with the displays.

See step 6 on page 18.

6. Measure your heart rate if desired.

See step 7 on page 19.

7. When you are finished exercising, remove the key from the console.

See step 8 on page 19.

HOW TO USE A PERFORMANCE WORKOUT

1. Insert the key into the console.

See HOW TO TURN ON THE POWER on page 17.

2. Select a performance workout.

To select a performance workout, press the Performance Workouts button repeatedly until the desired workout appears in the display.

When you select a performance workout, the workout number will appear in the upper display, the maximum incline level of the workout will flash in the lower left display, the maximum speed setting will flash in the lower right display, and then the workout duration will appear in the upper display. In addition, a profile of the speed settings of the workout will scroll across the display.

3. Enter your weight if desired.

For the most accurate calorie count, enter your weight into the console by pressing the Wt. increase and decrease buttons repeatedly. Note: Once you have entered your weight, your weight will be saved in memory.

4. Select the duration of the workout if desired.

If you have selected a performance workout, you can set the duration of the workout to a time between 15 and 45 minutes, in increments of 5 minutes. To set the duration of the workout press the Time increase or decrease button until the desired time is selected.

5. Start the workout.

See step 4 on page 20.

6. Follow your progress with the displays.

See step 6 on page 18.

7. Measure your heart rate if desired.

See step 7 on page 19.

8. When you are finished exercising, remove the key from the console.

See step 8 on page 19.

HOW TO USE AN IFIT WORKOUT

To purchase iFit cards, go to www.iFit.com or call the telephone number on the front cover of this manual. iFit cards are also available at select stores.

1. Insert the key into the console.

See HOW TO TURN ON THE POWER on page 17.

2. Insert an iFit card and select a workout.

To use an iFit workout, insert an iFit card into the iFit slot; make sure that the iFit card is oriented so the metal contacts are face-down and are inserted into the iFit slot.

Next, select an iFit workout by pressing the iFit increase or decrease button. When an iFit workout is selected, the maximum incline level of the workout will flash in the lower left display, the maximum speed setting will appear in the lower right display, and then the workout duration will appear in the lower left display. In addition, a profile of the speed settings of the workout will scroll across the display.

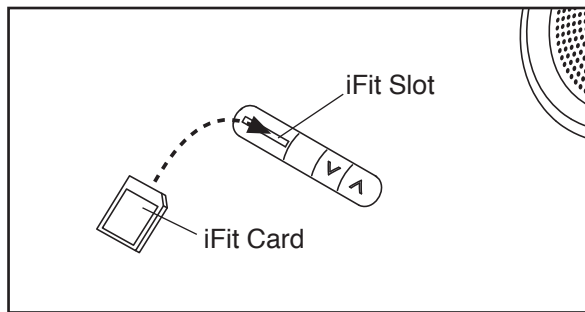

Each iFit workout is divided into several one-minute segments. One speed setting and one incline setting are programmed for each segment. Note: The same speed setting and/or incline setting may be programmed for consecutive segments.

3. Start the workout.

Press the Start button or the Speed increase button to start the workout. A moment after you press the button, the treadmill will automatically adjust to the first speed and incline settings of the workout. Hold the handrails and begin walking.

During the workout, the voice of a personal trainer will guide you through the workout. The iFit workout will function in the same way as a calorie workout (see step 4 on page 20).

If the speed or incline setting for the current segment is too high or too low, you can override the setting by pressing the Speed or Incline buttons; **however, when the next segment begins, the treadmill will automatically adjust to the speed and incline settings for the next segment.**

To stop the workout at any time, press the Stop button. To restart the workout, press the Start button. The walking belt will begin to move at 2 Km/H. When the next segment of the workout begins, the treadmill will automatically adjust to the speed and incline settings for the next segment.

4. Follow your progress with the displays.

See step 6 on page 18.

5. Measure your heart rate if desired.

See step 7 on page 19.

6. When you are finished exercising, remove the key from the console.

See step 8 on page 19.

CAUTION: Always remove iFit cards from the iFit slot when you are not using them.

THE INFORMATION MODE

The console features an information mode that keeps track of the total distance that the walking belt has moved and the total number of hours that the treadmill has been used. The information mode also allows you to select metric or English units of measurement, and to turn on and turn off the display demo mode.

To select the information mode, hold down the Stop button while inserting the key into the console and then release the Stop button. When the information mode is selected, the following information will be shown:

The upper display will show the total number of hours the treadmill has been used.



The lower left display will show the total number of kilometers (or miles) that the walking belt has moved.



An M for metric kilometers and kilograms or an E for English miles and pounds will appear in the lower right display. Press the Speed increase button to change the unit of measurement if desired.



The console features a display demo mode, designed to be used if the treadmill is displayed in a store. While the demo mode is turned on, the console will function normally when you plug in the power cord, press the power switch into the reset position, and insert the key into the console. However, when you remove the key, the displays will remain lit, although the buttons will not function. If the demo mode is turned on, a "d" will appear in the lower right display while the information mode is selected. To turn on or turn off the demo mode, press the Speed decrease button.



To exit the information mode, remove the key from the console.

HOW TO USE THE STEREO SOUND SYSTEM

To play music or audio books through the console's stereo speakers, you must connect your MP3 player, CD player, or other personal audio player to the console through the MP3 jack.

Plug one end of your audio wire into the audio jack on the console. Plug the other end into a jack on your MP3 player, CD player, or other personal audio player. **Make sure that your audio wire is fully plugged in.**

Next, press the Play button on your MP3 player, CD player, or other personal audio player. Adjust the volume on your personal audio player or press the volume increase and decrease buttons on the console.

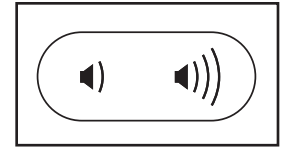

If you are using a personal CD player and the CD skips, set the CD player on the floor or another flat surface instead of on the console.

THE OPTIONAL CHEST PULSE SENSOR

An optional chest pulse sensor offers hands-free operation as it tracks your heart rate during your workouts. **To purchase the optional chest pulse sensor, call the telephone number on the front cover of this manual.**

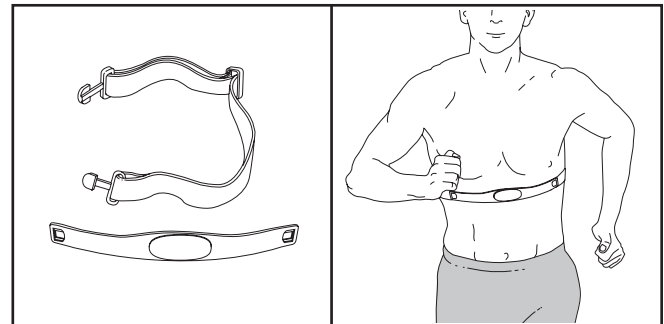

HOW TO FOLD AND MOVE THE TREADMILL

HOW TO FOLD THE TREADMILL

To avoid damaging the treadmill, adjust the incline to the lowest position before you fold the treadmill. Then, remove the key and unplug the power cord. **CAUTION: You must be able to safely lift 45 lbs. (20 kg) to raise, lower, or move the treadmill.**

1. Hold the metal frame firmly in the location shown by the arrow below. **CAUTION: Do not hold the frame by the plastic foot rails. Bend your legs and keep your back straight.**

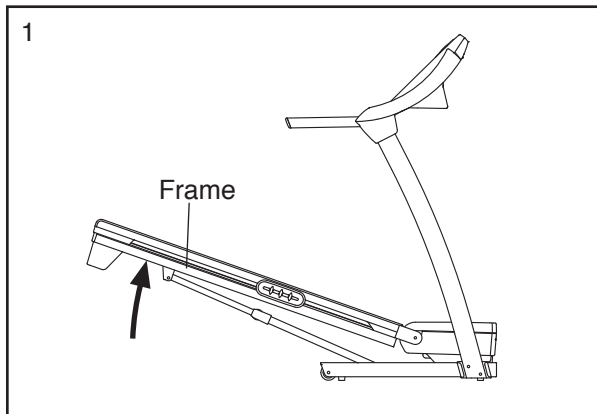

2. Raise the frame until the latch knob locks in the storage position. **CAUTION: Make sure that the latch knob locks.**

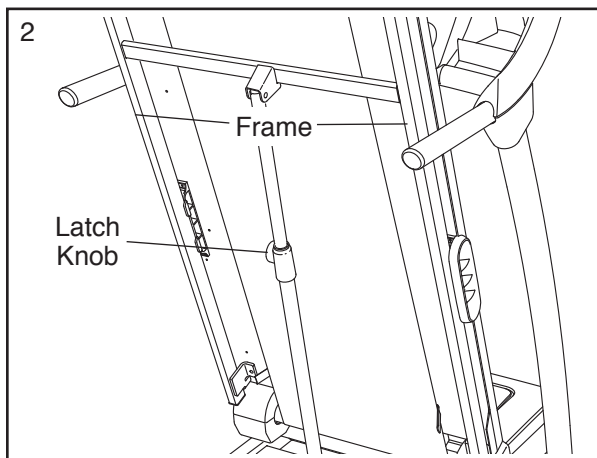

To protect the floor or carpet, place a mat under the treadmill. Keep the treadmill out of direct sunlight. Do not leave the treadmill in the storage position in temperatures above 85° F (30° C).

HOW TO MOVE THE TREADMILL

Before moving the treadmill, fold it as described at the left. **CAUTION: Make sure that the latch knob is locked in the storage position. Moving the treadmill may require two people.**

1. Hold the frame and one of the handrails, and place one foot against a wheel.

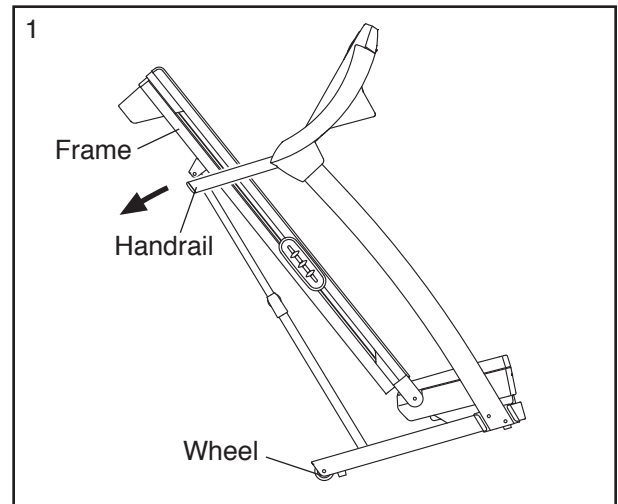

2. Pull back on the handrail until the treadmill will roll on the wheels, and carefully move it to the desired location. **CAUTION: Do not move the treadmill without tipping it back, do not pull on the frame, and do not move the treadmill over an uneven surface.**
3. Place one foot against a wheel, and carefully lower the treadmill.

HOW TO LOWER THE TREADMILL FOR USE

1. **See drawing 2.** Hold the upper end of the treadmill with your right hand. Pull the latch knob to the left; if necessary, push the frame forward slightly. Pivot the frame downward a few inches, and release the latch knob.
2. **See drawing 1 at the left.** Hold the metal frame firmly with both hands, and lower it to the floor. **CAUTION: Do not hold the frame by the plastic foot rails, and do not drop the frame. Bend your legs and keep your back straight.**

TROUBLESHOOTING

Most treadmill problems can be solved by following the steps below. Find the symptom that applies, and follow the steps listed. If further assistance is needed, please see the front cover of this manual.

PROBLEM: The power does not turn on

- SOLUTION:**
- a. Make sure that the power cord is plugged into a properly earthed outlet (see page 15). If an extension cord is needed, use only a 3-conductor, 14-gauge (1 mm²) cord that is no longer than 5 ft. (1.5 m).
 - b. After the power cord has been plugged in, make sure that the key is inserted into the console.
 - c. Check the power switch located on the treadmill frame near the power cord. If the switch protrudes as shown, the switch has tripped. To reset the switch, wait for five minutes and then press the switch back in.

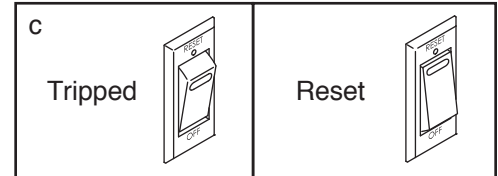

PROBLEM: The power turns off during use

- SOLUTION:**
- a. Check the power switch (see the drawing above). If the switch has tripped, wait for five minutes and then press the switch back in.
 - b. Make sure that the power cord is plugged in. If the power cord is plugged in, unplug it, wait for five minutes, and then plug it back in.
 - c. Remove the key from the console. Reinsert the key into the console.
 - d. If the treadmill still will not run, please see the front cover of this manual.

PROBLEM: The console displays remain lit when you remove the key from the console

- SOLUTION:**
- a. The console features a display demo mode, designed to be used if the treadmill is displayed in a store. If the displays remain lit when you remove the key, the demo mode is turned on. To turn off the demo mode, hold down the Stop button for a few seconds. If the displays are still lit, see THE INFORMATION MODE on page 23 to turn off the demo mode.

PROBLEM: The displays of the console do not function properly

- SOLUTION:**
- a. Press the Incline buttons and adjust the incline level of the treadmill to 5 percent.

Remove the key from the console and **UNPLUG THE POWER CORD**. With the help of a second person, carefully tip down the Uprights (85, 89). There may be two Belly Pan Screws (A) in the bottom of the Belly Pan (84). If there are, remove them. Note: A Phillips screwdriver with a shaft at least 5 in. (13 cm) long is required.

Then, raise the Uprights (85, 89).

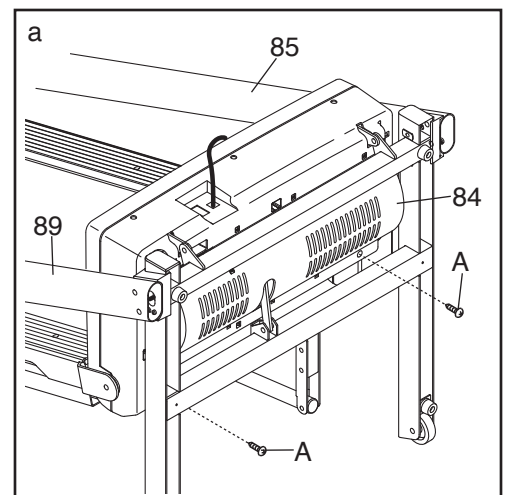

Remove the three M4.2 x 19mm Hood Screws (12) and carefully pivot the Motor Hood (67) off.

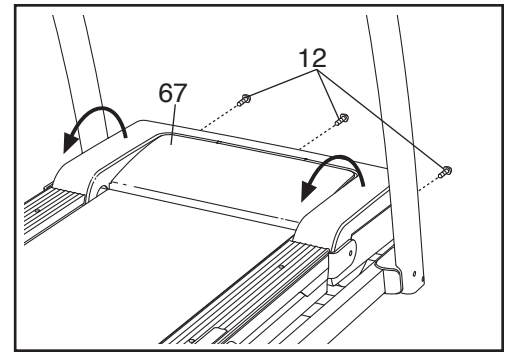

Locate the Reed Switch (70) and the Magnet (51) on the left side of the Pulley (53). Turn the Pulley until the Magnet is aligned with the Reed Switch. **Make sure that the gap between the Magnet and the Reed Switch is about 1/8 in. (3 mm).** If necessary, loosen the M4.2 x 19mm Screw (1), move the Reed Switch slightly, and then retighten the Screw. Reattach the Motor Hood (not shown). Reattach the two Belly Pan Screws (not shown), if necessary. Run the treadmill for a few minutes to check for a correct speed reading.

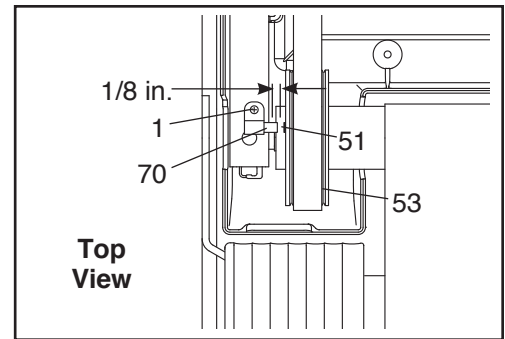

PROBLEM: The incline of the treadmill does not change correctly

SOLUTION: a. With the key in the console, press one of the Incline buttons. **While the incline is changing, remove the key.** After a few seconds, reinsert the key. The treadmill will automatically rise to the maximum incline level and then return to the minimum level. This will recalibrate the incline system.

PROBLEM: The walking belt slows when walked on

SOLUTION: a. If an extension cord is needed, use only a 3-conductor, 14-gauge (1 mm²) cord that is no longer than 5 ft. (1.5 m).

b. If the walking belt is overtightened, treadmill performance may decrease and the walking belt may become damaged. Remove the key and **UNPLUG THE POWER CORD.** Using the hex key, turn both idler roller bolts counterclockwise, 1/4 of a turn. When the walking belt is properly tightened, you should be able to lift each edge of the walking belt 2 to 3 in. (5 to 7 cm) off the walking platform. Be careful to keep the walking belt centered. Then, plug in the power cord, insert the key, and run the treadmill for a few minutes. Repeat until the walking belt is properly tightened.

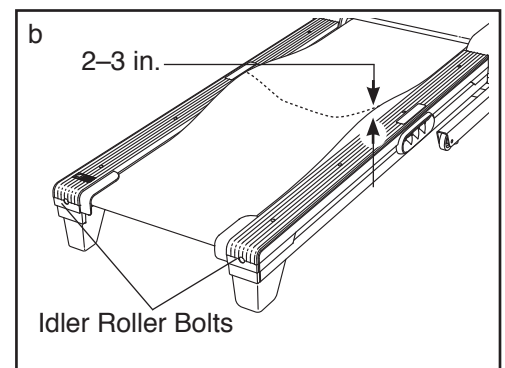

c. If the walking belt still slows when walked on, see the front cover of this manual.

PROBLEM: The walking belt is off-center or slips when walked on

SOLUTION: a. **If the walking belt is off-center**, first remove the key and **UNPLUG THE POWER CORD**. **If the walking belt has shifted to the left**, use the hex key to turn the left idler roller bolt clockwise 1/2 of a turn; **if the walking belt has shifted to the right**, turn the bolt counterclockwise 1/2 of a turn. Be careful not to overtighten the walking belt. Then, plug in the power cord, insert the key, and run the treadmill for a few minutes. Repeat until the walking belt is centered.

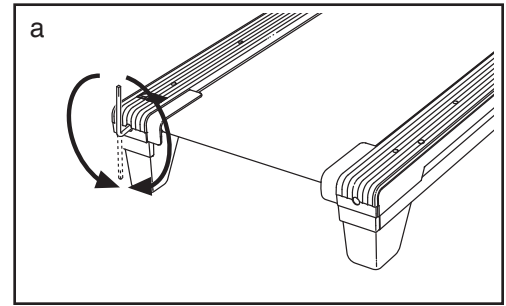

b. **If the walking belt slips when walked on**, first remove the key and **UNPLUG THE POWER CORD**. Using the hex key, turn both idler roller bolts clockwise, 1/4 of a turn. When the walking belt is correctly tightened, you should be able to lift each side of the walking belt 2 to 3 in. (5 to 7 cm) off the walking platform. Be careful to keep the walking belt centered. Then, plug in the power cord, insert the key, and carefully walk on the treadmill for a few minutes. Repeat until the walking belt is properly tightened.

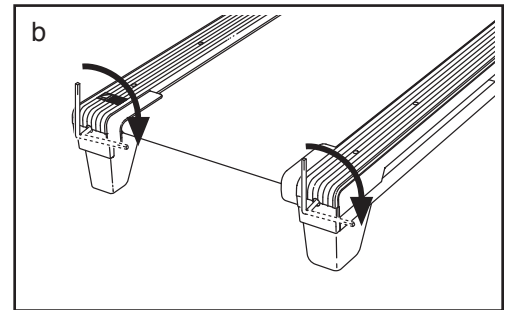

EXERCISE GUIDELINES

⚠ WARNING: Before beginning this or any exercise program, consult your physician. This is especially important for persons over age 35 or persons with pre-existing health problems.

The pulse sensor is not a medical device. Various factors may affect the accuracy of heart rate readings. The pulse sensor is intended only as an exercise aid in determining heart rate trends in general.

These guidelines will help you to plan your exercise program. For detailed exercise information, obtain a reputable book or consult your physician. Remember, proper nutrition and adequate rest are essential for successful results.

EXERCISE INTENSITY

Whether your goal is to burn fat or to strengthen your cardiovascular system, exercising at the proper intensity is the key to achieving results. You can use your heart rate as a guide to find the proper intensity level. The chart below shows recommended heart rates for fat burning and aerobic exercise.

165	155	145	140	130	125	115	♥
145	138	130	125	118	110	103	♥
125	120	115	110	105	95	90	♥
<hr/>							
20	30	40	50	60	70	80	

To find the proper intensity level, find your age at the bottom of the chart (ages are rounded off to the nearest ten years). The three numbers listed above your age define your “training zone.” The lowest number is the heart rate for fat burning, the middle number is the heart rate for maximum fat burning, and the highest number is the heart rate for aerobic exercise.

Burning Fat—To burn fat effectively, you must exercise at a low intensity level for a sustained period of time. During the first few minutes of exercise, your body uses *carbohydrate calories* for energy. Only after the first few minutes of exercise does your body begin to use stored *fat calories* for energy. If your goal is to burn fat, adjust the intensity of your exercise until your heart rate is near the lowest number in your training zone. For maximum fat burning, exercise with your heart rate near the middle number in your training zone.

Aerobic Exercise—If your goal is to strengthen your cardiovascular system, you must perform aerobic exercise, which is activity that requires large amounts of oxygen for prolonged periods of time. For aerobic exercise, adjust the intensity of your exercise until your heart rate is near the highest number in your training zone.

WORKOUT GUIDELINES

Warming Up—Start with 5 to 10 minutes of stretching and light exercise. A warm-up increases your body temperature, heart rate, and circulation in preparation for exercise.

Training Zone Exercise—Exercise for 20 to 30 minutes with your heart rate in your training zone. (During the first few weeks of your exercise program, do not keep your heart rate in your training zone for longer than 20 minutes.) Breathe regularly and deeply as you exercise—never hold your breath.

Cooling Down—Finish with 5 to 10 minutes of stretching. Stretching increases the flexibility of your muscles and helps to prevent post-exercise problems.

EXERCISE FREQUENCY

To maintain or improve your condition, complete three workouts each week, with at least one day of rest between workouts. After a few months of regular exercise, you may complete up to five workouts each week, if desired. Remember, the key to success is to make exercise a regular and enjoyable part of your everyday life.

SUGGESTED STRETCHES

The correct form for several basic stretches is shown at the right. Move slowly as you stretch—never bounce.

1. Toe Touch Stretch

Stand with your knees bent slightly and slowly bend forward from your hips. Allow your back and shoulders to relax as you reach down toward your toes as far as possible. Hold for 15 counts, then relax. Repeat 3 times. Stretches: Hamstrings, back of knees and back.

2. Hamstring Stretch

Sit with one leg extended. Bring the sole of the opposite foot toward you and rest it against the inner thigh of your extended leg. Reach toward your toes as far as possible. Hold for 15 counts, then relax. Repeat 3 times for each leg. Stretches: Hamstrings, lower back and groin.

3. Calf/Achilles Stretch

With one leg in front of the other, reach forward and place your hands against a wall. Keep your back leg straight and your back foot flat on the floor. Bend your front leg, lean forward and move your hips toward the wall. Hold for 15 counts, then relax. Repeat 3 times for each leg. To cause further stretching of the achilles tendons, bend your back leg as well. Stretches: Calves, achilles tendons and ankles.

4. Quadriceps Stretch

With one hand against a wall for balance, reach back and grasp one foot with your other hand. Bring your heel as close to your buttocks as possible. Hold for 15 counts, then relax. Repeat 3 times for each leg. Stretches: Quadriceps and hip muscles.

5. Inner Thigh Stretch

Sit with the soles of your feet together and your knees outward. Pull your feet toward your groin area as far as possible. Hold for 15 counts, then relax. Repeat 3 times. Stretches: Quadriceps and hip muscles.



PART LIST

Model No. PETL69910.0 R0413A

To locate the parts listed below, see the EXPLODED DRAWING near the end of this manual.

Key No.	Qty.	Description	Key No.	Qty.	Description
1	9	M4.2 x 19mm Screw	51	1	Magnet
2	2	M4 x 45mm Screw	52	1	Motor Belt
3	4	M4.2 x 25mm Tek Screw	53	1	Drive Roller/Pulley
4	11	#8 x 1/2" Ground Screw	54	1	Walking Belt
5	6	M8 x 25mm Patch Bolt	55	1	Walking Platform
6	6	3/8" Locknut	56	1	Frame
7	1	3/8" x 1 3/4" Patch Bolt	57	2	Roller Bracket
8	2	M10 x 95mm Patch Bolt	58	1	Right Foot Rail
9	4	M10 Star Washer	59	1	Access Door
10	8	M8 Star Washer	60	1	Storage Latch
11	5	M4.2 x 13mm Screw	61	1	Latch Bracket
12	3	M4.2 x 19mm Hood Screw	62	1	Right Foot
13	3	Hood Clip	63	1	Idler Roller
14	–	Not Used	64	2	Roller Bracket Plate
15	2	M8 x 35mm Bolt	65	1	Left Foot
16	2	M8 x 90mm Bolt	66	2	Console Clamp
17	2	Foot Rail Decal	67	1	Motor Hood
18	2	M10 x 30mm Bolt	68	1	Drive Motor
19	4	M10 Nut	69	3	Lift Frame Cable Tie
20	1	3/8" x 1 3/4" Bolt	70	1	Reed Switch
21	1	3/8" x 1 1/2" Bolt	71	1	Reed Switch Clamp
22	1	Controller Ground Wire	72	2	Frame Spacer
23	2	3/8" x 1" Bolt	73	2	1/4" Star Washer
24	2	3/8" Nut	74	1	Lift Frame
25	1	M6 x 45mm Bolt	75	1	Incline Stop Bracket
26	2	M6 x 70mm Bolt	76	1	Lift Frame/Roller Ground Wire
27	2	M6 Lock Washer	77	1	Lift Motor
28	2	M6 Flat Washer	78	1	Lift Motor Spacer
29	8	M5 x 25mm Screw	79	1	Lift Motor Wire
30	2	1/4" Motor Bolt	80	1	Controller
31	2	M10 x 50mm Bolt	81	1	Power Cord
32	4	M4.2 x 13mm Washer Head Screw	82	1	UK Power Cord
33	5	M4.2 x 10mm Screw	83	1	Power Switch
34	2	M8 Cage Nut	84	1	Belly Pan
35	10	M4 x 19mm Screw	85	1	Left Upright
36	2	M8 Nut	86	1	Left Upright Spacer
37	3	3/8" x 2" Bolt	87	2	Base Cap
38	2	Cable Tie	88	1	Upright Wire
39	9	8" Cable Tie	89	1	Right Upright
40	2	Releasable Tie	90	4	Bolt Spacer
41	1	Key/Clip	91	1	Right Upright Spacer
42	1	6 mm Hex Key	92	4	Base Foot
43	1	4 mm Hex Key	93	2	Caution Decal
44	1	5 mm Hex Key	94	2	Base Foot Spacer
45	1	Hex Key	95	1	Base
46	1	Left Foot Rail	96	1	Lift Frame/Base Ground Wire
47	1	Warning Decal	97	2	Wheel
48	2	Platform Cushion	98	2	Handrail Cap
49	2	Belt Guide	99	1	Left Handrail
50	2	Frame Cap	100	1	Pulse Bar

Key No.	Qty.	Description	Key No.	Qty.	Description
101	1	Right Handrail	114	2	M10 x 68mm Patch Bolt
102	1	Console Ground Wire	115	2	M8 Flange Nut
103	1	Console Base	116	8	M4 x 13mm Screw
104	1	Left Accessory Tray	117	2	Motor Bushing
105	1	Console	118	1	Motor Isolator
106	1	Right Accessory Tray	119	1	Transformer
107	4	#8 x 1" Screw	120	1	Filter
108	2	M5 x 16mm Bolt	121	1	Receptacle
109	1	Left Upright Cover	122	1	Electronics Bracket
110	1	Right Upright Cover	123	2	#8 Star Washer
111	1	Console Frame	124	6	M4 x 16mm Screw
112	1	Not Used	*	–	User's Manual
113	4	5/16" x 5/8" Patch Bolt			

Note: Specifications are subject to change without notice. For information about ordering replacement parts, see the back cover of this manual. *These parts are not illustrated.

EXPLODED DRAWING A

Model No. PETL69910.0 R0413A

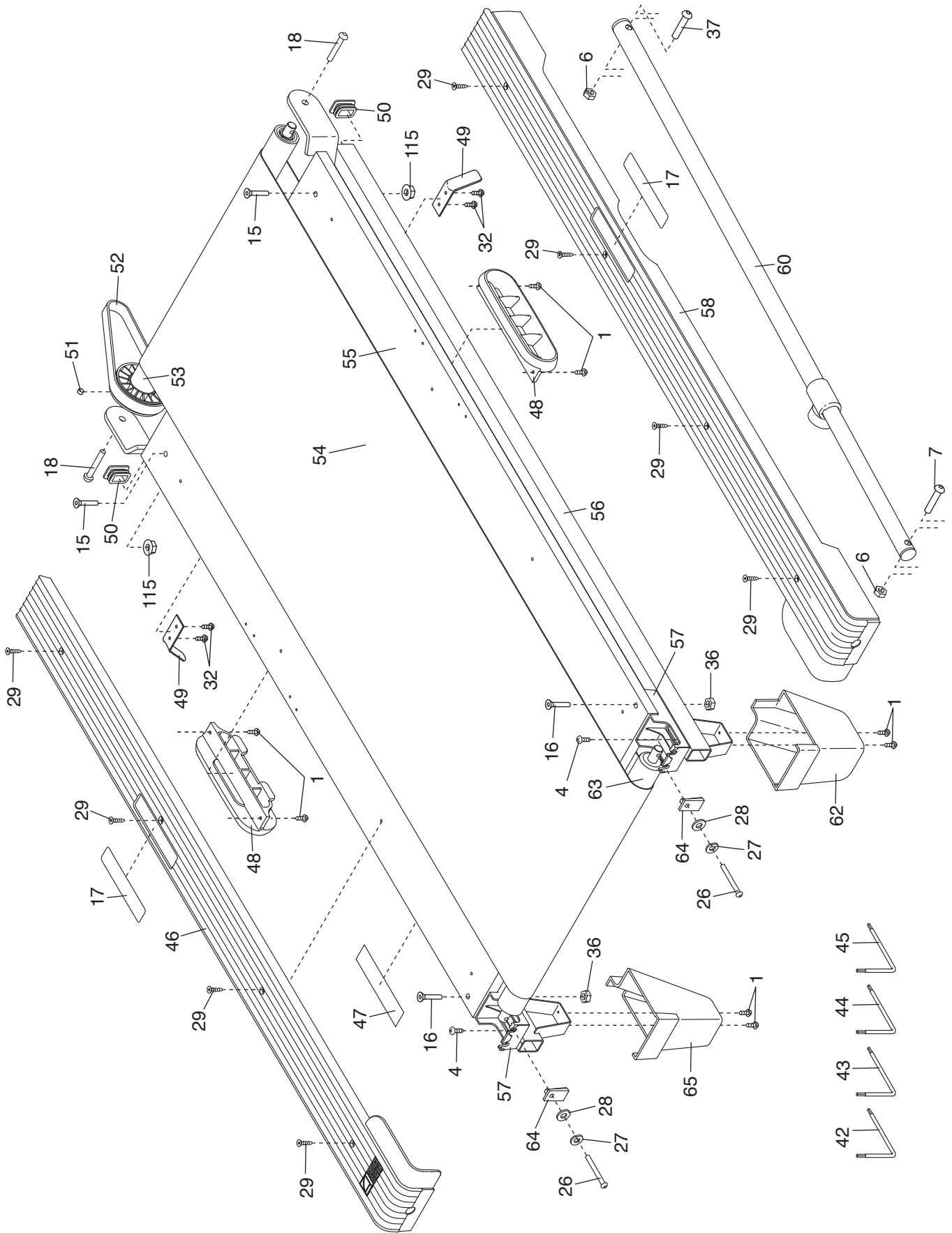

EXPLODED DRAWING B

Model No. PETL69910.0 R0413A

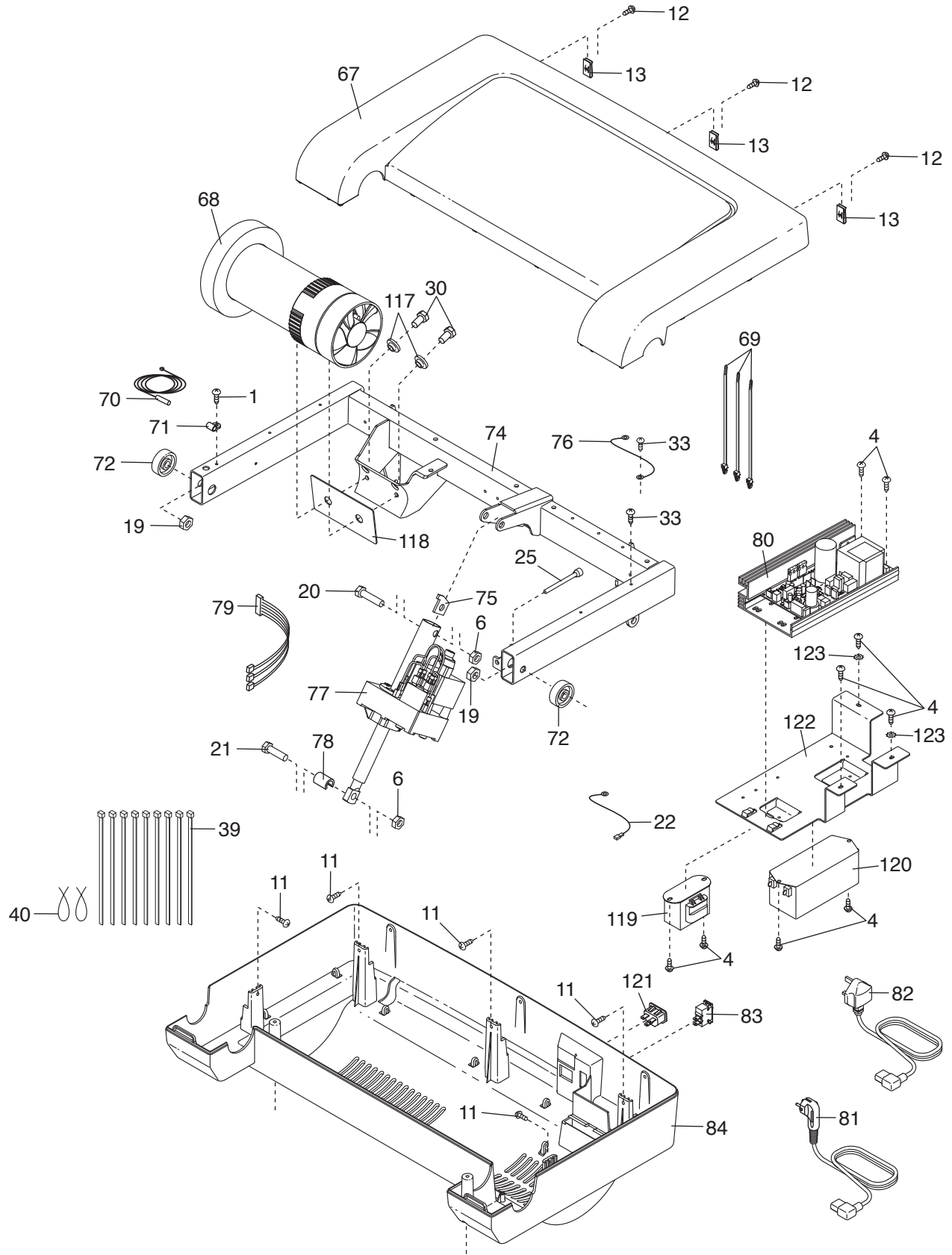

EXPLODED DRAWING C

Model No. PETL69910.0 R0413A

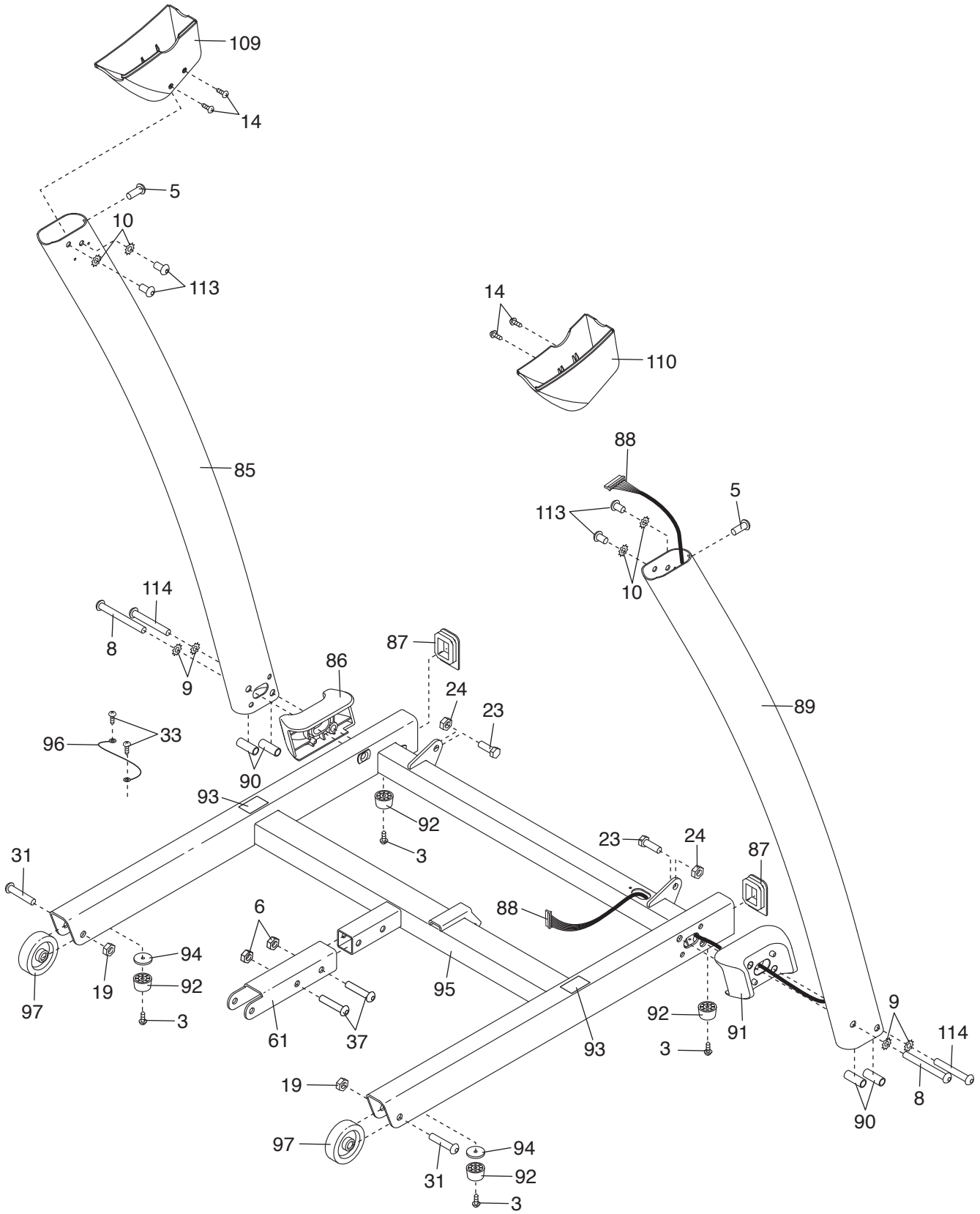

EXPLODED DRAWING D

Model No. PETL69910.0 R0413A

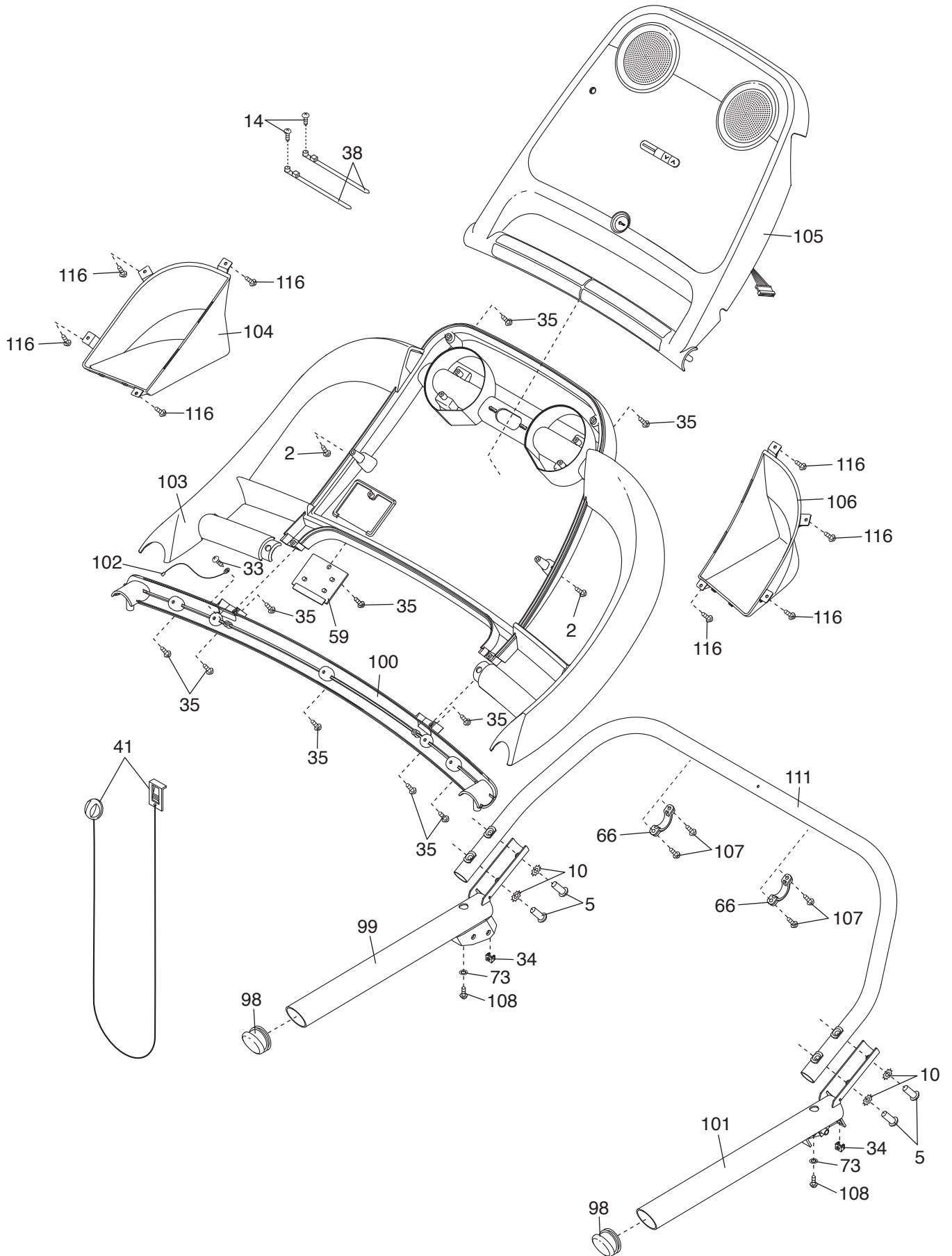

ORDERING REPLACEMENT PARTS

To order replacement parts, please see the front cover of this manual. To help us assist you, be prepared to provide the following information when contacting us:

- the model number and serial number of the product (see the front cover of this manual)
- the name of the product (see the front cover of this manual)
- the key number and description of the replacement part(s) (see the PART LIST and the EXPLODED DRAWING near the end of this manual)

RECYCLING INFORMATION

This electronic product must not be disposed of in municipal waste. To preserve the environment, this product must be recycled after its useful life as required by law.

Please use recycling facilities that are authorized to collect this type of waste in your area. In doing so, you will help to conserve natural resources and improve European standards of environmental protection. If you require more information about safe and correct disposal methods, please contact your local city office or the establishment where you purchased this product.

