

PRO-FORM[®]

ENDURANCE M7

Model No. PETL80914.1

Serial No. _____

Write the serial number in the space above for reference.

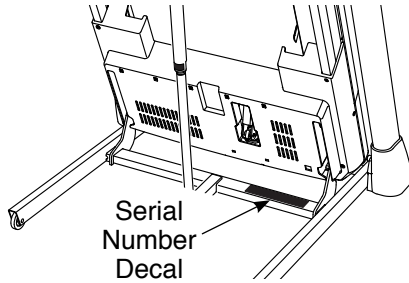

USER'S MANUAL

CUSTOMER SERVICE

UNITED KINGDOM

Call: 0330 123 1045

From Ireland: 053 92 36102

Website: www.iconsupport.eu

E-mail: csuk@iconeurope.com

Write:

ICON Health & Fitness, Ltd.

Unit 1D, The Gateway

Fryers Way, Silkwood Park

OSSETT

WF5 9TJ

UNITED KINGDOM

AUSTRALIA

Call: 1800 993 770

E-mail: australiacc@iconfitness.com

Write:

ICON Health & Fitness

PO Box 635

WINSTON HILLS NSW 2153

AUSTRALIA



⚠ CAUTION

Read all precautions and instructions in this manual before using this equipment. Save this manual for future reference.

TABLE OF CONTENTS

WARNING DECAL PLACEMENT 2

IMPORTANT PRECAUTIONS 3

BEFORE YOU BEGIN 5

PART IDENTIFICATION CHART 6

ASSEMBLY 7

HOW TO USE THE TREADMILL 16

HOW TO FOLD AND MOVE THE TREADMILL 22

MAINTENANCE AND TROUBLESHOOTING 23

EXERCISE GUIDELINES 26

PART LIST 27

EXPLODED DRAWING 28

ORDERING REPLACEMENT PARTS Back Cover

RECYCLING INFORMATION Back Cover

WARNING DECAL PLACEMENT

This drawing shows the locations of the warning decals. **If a decal is missing or illegible, call the telephone number on the front cover of this manual and request a free replacement decal. Apply the decal in the location shown.** Note: The decals may not be shown at actual size.

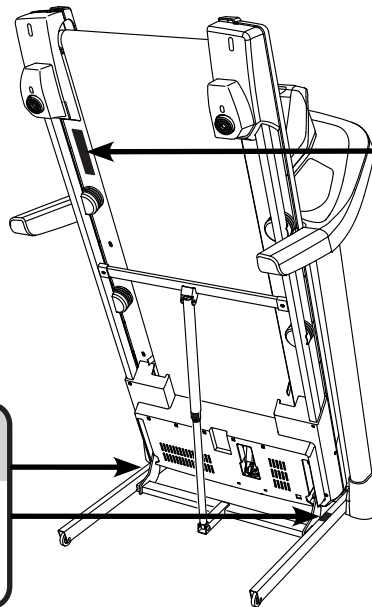

WARNING:

Protect yourself and others from risk of serious injury. Read the user's manual, and:

- Stand only on the side rails when starting or stopping treadmill.
- Change speed in small increments.
- Hold handrails to prevent falling, and always wear the safety clip while operating the treadmill.
- Stop if you feel faint, dizzy, or short of breath.
- Fully engage the storage latch before the treadmill is moved or stored.
- Incline should be set to zero before folding the treadmill into a storage position.
- Never allow children on or around the treadmill.
- Remove the safety key when treadmill is not in use.
- Keep clothing, fingers, and hair away from moving parts.
- Never try to adjust or fix the belt while it is moving.
- Always wear athletic shoes while operating the treadmill.

IMPORTANT PRECAUTIONS

⚠️ WARNING: To reduce the risk of burns, fire, electric shock, or injury to persons, read all important precautions and instructions in this manual and all warnings on your treadmill before using your treadmill. ICON assumes no responsibility for personal injury or property damage sustained by or through the use of this product.

1. It is the responsibility of the owner to ensure that all users of this treadmill are adequately informed of all warnings and precautions.
2. Before beginning any exercise program, consult your physician. This is especially important for persons over age 35 or persons with pre-existing health problems.
3. Use the treadmill only as described in this manual.
4. The treadmill is intended for home use only. Do not use the treadmill in any commercial, rental, or institutional setting.
5. Keep the treadmill indoors, away from moisture and dust. Do not put the treadmill in a garage or covered patio, or near water.
6. Place the treadmill on a level surface, with at least 8 ft. (2.4 m) of clearance behind it and 2 ft. (0.6 m) on each side. Do not place the treadmill on any surface that blocks air openings. To protect the floor or carpet from damage, place a mat under the treadmill.
7. Do not operate the treadmill where aerosol products are used or where oxygen is being administered.
8. Keep children under age 12 and pets away from the treadmill at all times.
9. The treadmill should be used only by persons weighing 330 lbs. (150 kg) or less.
10. Never allow more than one person on the treadmill at a time.
11. Wear appropriate exercise clothes while using the treadmill. Do not wear loose clothes that could become caught in the treadmill. Athletic support clothes are recommended for both men and women. *Always wear athletic shoes. Never use the treadmill with bare feet, wearing only stockings, or in sandals.*
12. When connecting the power cord (see page 16), plug the power cord into an earthed circuit. No other appliance should be on the same circuit. When replacing the fuse in the power cord adapter, insert an ASTA-approved BS1362, 13-amp fuse into the fuse carrier.
13. If an extension cord is needed, use only a 3-conductor, 14-gauge (1 mm²) cord that is no longer than 5 ft. (1.5 m).
14. Keep the power cord away from heated surfaces.
15. Never move the walking belt while the power is turned off. Do not operate the treadmill if the power cord or plug is damaged, or if the treadmill is not working properly. (See MAINTENANCE AND TROUBLESHOOTING on page 23 if the treadmill is not working properly.)
16. Read, understand, and test the emergency stop procedure before using the treadmill (see HOW TO TURN ON THE POWER on page 18).
17. Never start the treadmill while you are standing on the walking belt. Always hold the handrails while using the treadmill.
18. The treadmill is capable of high speeds. Adjust the speed in small increments to avoid sudden jumps in speed.
19. The heart rate monitor is not a medical device. Various factors, including the user's movement, may affect the accuracy of heart rate readings. The heart rate monitor is intended only as an exercise aid in determining heart rate trends in general.
20. Never leave the treadmill unattended while it is running. Always remove the key, press the power switch into the off position (see the drawing on page 5 for the location of the power switch), and unplug the power cord when the treadmill is not in use.

21. Do not attempt to move the treadmill until it is properly assembled. (See **ASSEMBLY** on page 7 and **HOW TO FOLD AND MOVE THE TREADMILL** on page 22.) You must be able to safely lift 45 lbs. (20 kg) to move the treadmill.
22. When folding or moving the treadmill, make sure that the storage latch is holding the frame securely in the storage position.
23. Do not change the incline of the treadmill by placing objects under the treadmill.
24. Never insert any object into any opening on the treadmill.
25. Inspect and properly tighten all parts of the treadmill regularly.
26. **DANGER:** Always unplug the power cord immediately after use, before cleaning the treadmill, and before performing the maintenance and adjustment procedures described in this manual. Never remove the motor hood unless instructed to do so by an authorized service representative. Servicing other than the procedures in this manual should be performed by an authorized service representative only.
27. Over exercising may result in serious injury or death. If you feel faint or if you experience pain while exercising, stop immediately and cool down.

SAVE THESE INSTRUCTIONS

BEFORE YOU BEGIN

Thank you for selecting the new PROFORM® ENDURANCE M7 treadmill. The ENDURANCE M7 treadmill provides an impressive selection of features designed to make your workouts at home more effective and enjoyable.

For your benefit, read this manual carefully before you use the treadmill. If you have questions after

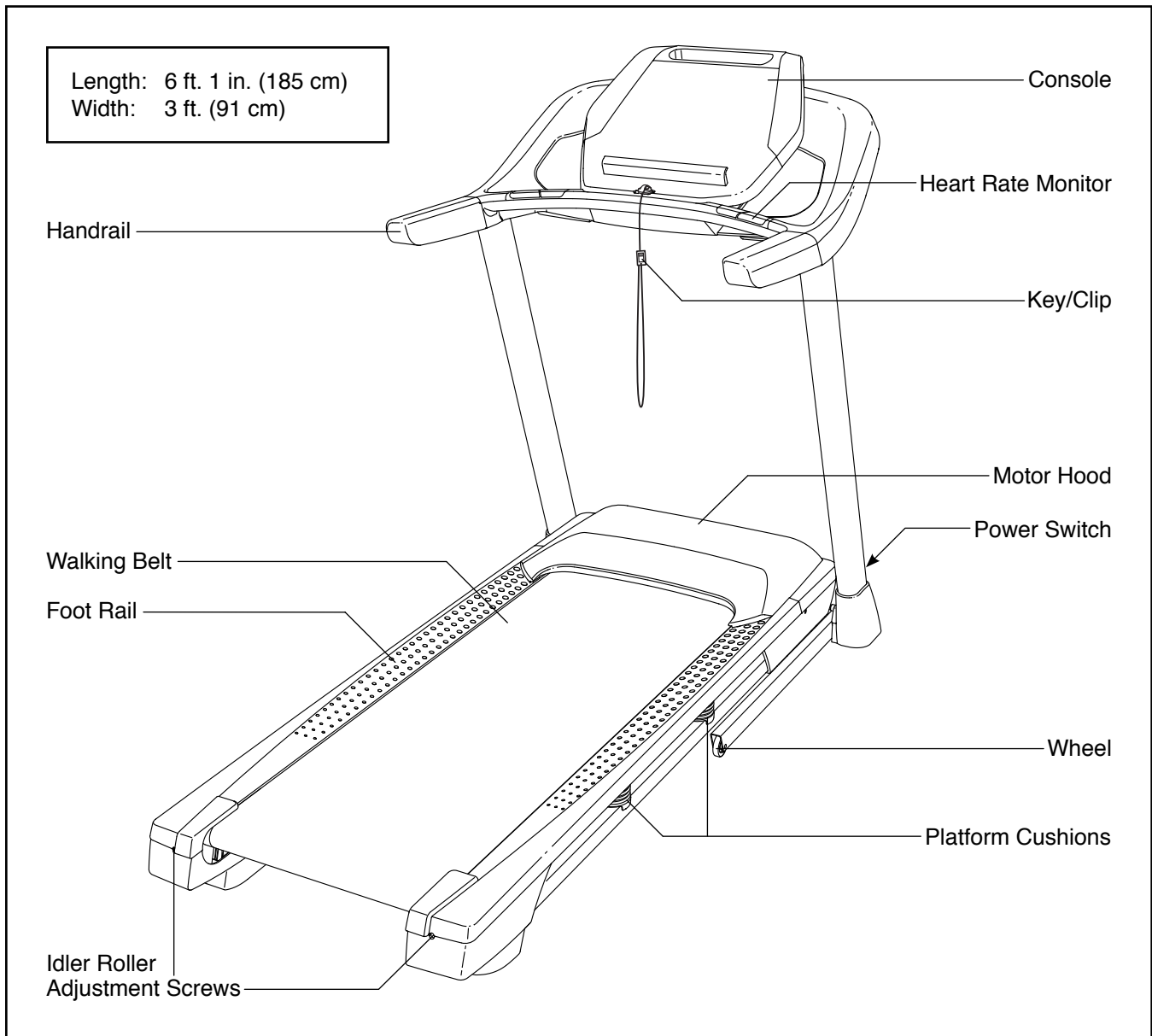

reading this manual, please see the front cover of this manual. To help us assist you, note the product model number and serial number before contacting us. The model number and the location of the serial number decal are shown on the front cover of this manual.

Before reading further, please familiarize yourself with the parts that are labeled in the drawing below.

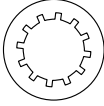
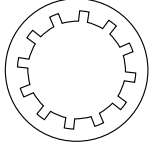
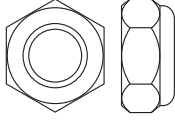
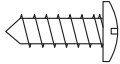
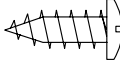
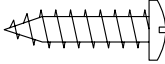
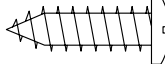

PART IDENTIFICATION CHART

Use the drawings below to identify small parts used for assembly. The number in parentheses below each drawing is the key number of the part, from the PART LIST near the end of this manual. The number following the key number is the quantity used for assembly. **Note: If a part is not in the hardware kit, check to see whether it is preattached. Extra parts may be included.**

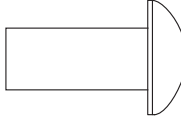
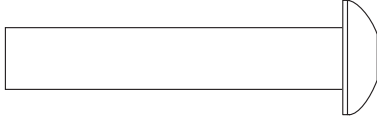
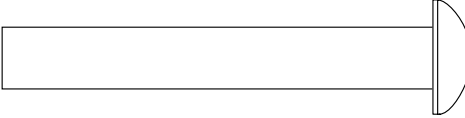
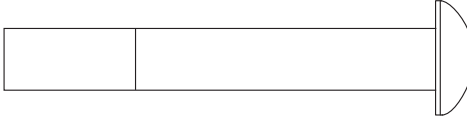
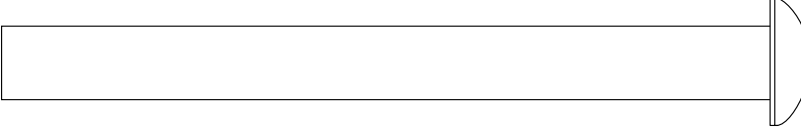
			
1/4" Star Washer (26)–8	5/16" Star Washer (11)–4	3/8" Star Washer (13)–6	5/16" Nut (34)–2
			
#8 x 1/2" Silver Screw (10)–1	#8 x 1/2" Screw (1)–8	#8 x 3/4" Screw (4)–8	#10 x 3/4" Screw (9)–4
			
Latch Spacer (98)–2	5/16" x 3/4" Screw (93)–2	5/16" x 1 3/4" Bolt (94)–1	
			
5/16" x 2 1/4" Screw (28)–4	5/16" x 2 1/4" Shoulder Bolt (95)–1		
			
	3/8" x 4" Screw (7)–6		

ASSEMBLY

- Assembly requires two persons.
- Place all parts in a cleared area and remove the packing materials. Do not dispose of the packing materials until you finish all assembly steps.
- After shipping, there may be an oily substance on the exterior of the treadmill. This is normal. If there is an oily substance on the treadmill, wipe it off with a soft cloth and a mild, non-abrasive cleaner.
- Left parts are marked “L” or “Left” and right parts are marked “R” or “Right.”

- To identify small parts, see page 6.
- Assembly requires the following tools:

the included hex keys



one Phillips screwdriver



To avoid damaging parts, do not use power tools.

1. **Go to www.iconsupport.eu on your computer and register your product.**

- activates your warranty
- saves you time if you ever need to contact Customer Service
- allows us to notify you of upgrades and offers

Note: If you do not have Internet access, call Customer Service (see the front cover of this manual) and register your product.

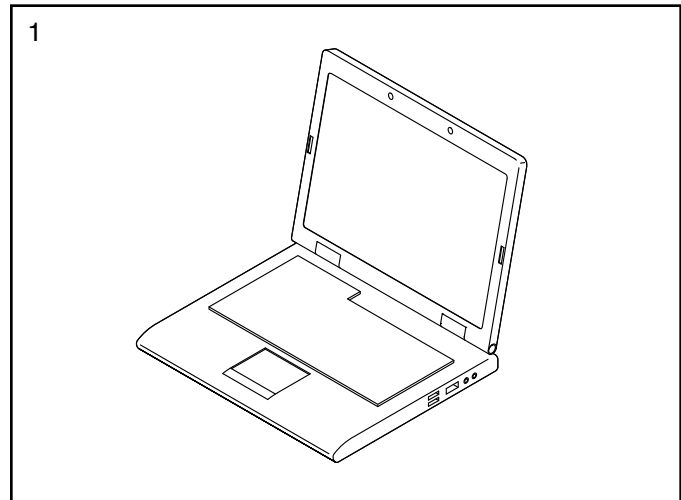

2. **Make sure that the power cord is unplugged.**

Press a Base Cap (74) into each side of the Base (85).

Identify the Right Upright (90). Have a second person hold the Right Upright near the Base (85).

See the inset drawing. Tie the wire tie in the Right Upright (90) securely around the end of the Upright Wire (81). Then, insert the Upright Wire into the lower end of the Right Upright as you pull the other end of the wire tie out of the Right Upright.

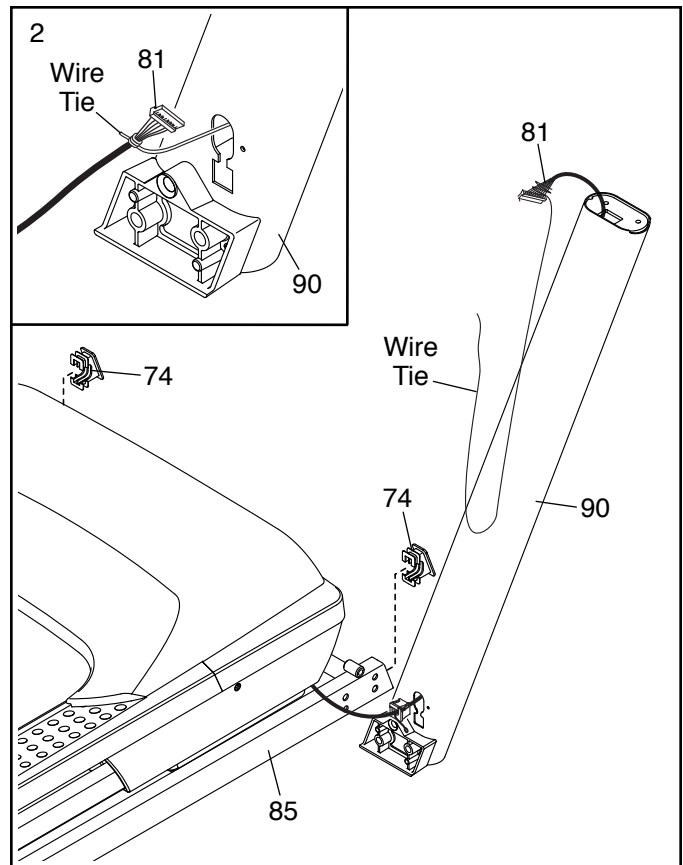

3. Lay the Right Upright (90) near the Base (85). Press the Grommet (77) into the square hole in the Right Upright. **Make sure not to pinch the ground wire.**

Then, attach the ground wire to the Right Upright (90) with a #8 x 1/2" Silver Screw (10).

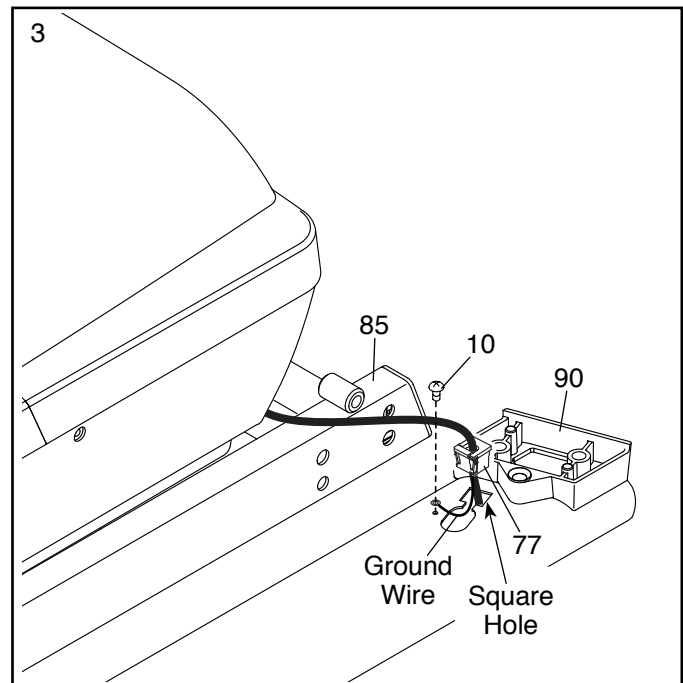

4. Hold the Right Upright (90) against the Base (85). **Be careful not to pinch the wires.** Partially tighten three 3/8" x 4" Screws (7) with three 3/8" Star Washers (13) into the Right Upright and the Base; **do not fully tighten the Screws yet.**

Attach the Left Upright (not shown) in the same way. Note: There are no wires on the left side.

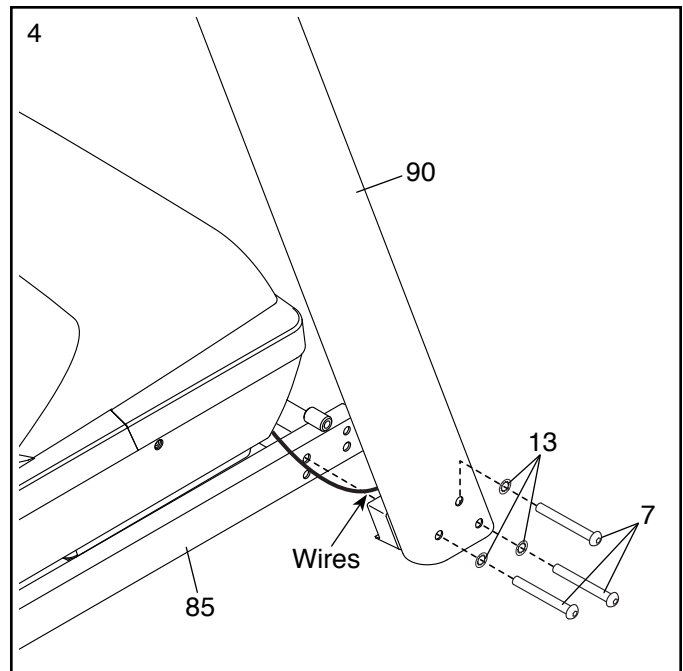

5. Identify the Left and Right Base Covers (82, 83). Slide the Left and Right Base Covers onto the Left and Right Uprights (89, 90) as shown.

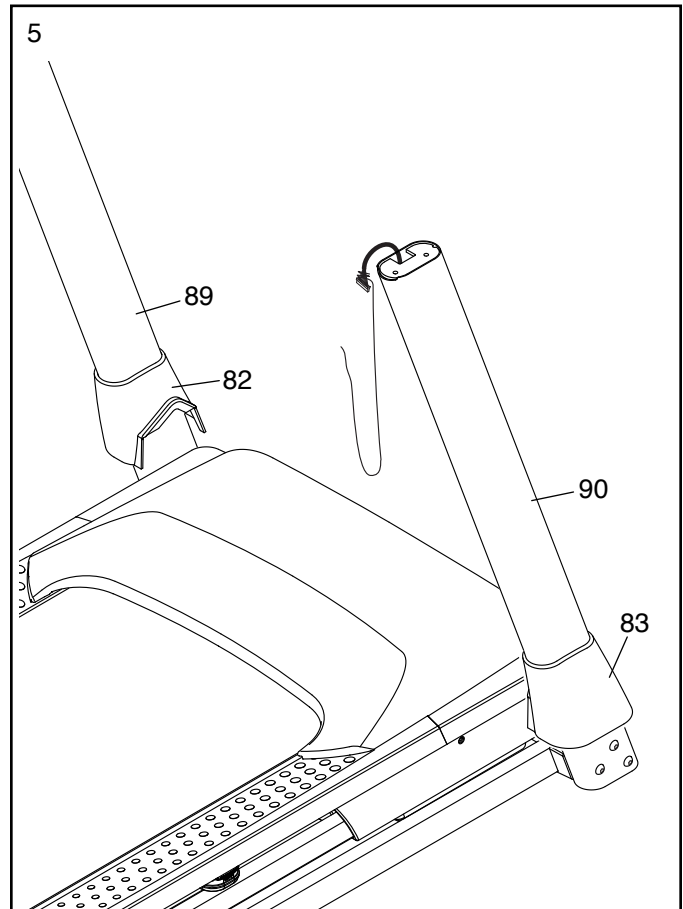

6. Set a Handrail (84) onto the Right Upright (90). **Make sure that the Upright Wire (81) is not pinched.**

Attach the Handrail (84) with two 5/16" x 2 1/4" Screws (28) and two 5/16" Star Washers (11). **Start both Screws, and then tighten them.**

Attach the other Handrail (not shown) in the same way. Note: There is no wire on the left side.

Remove and discard the two indicated screws (A) from both Handrails (84) (only one side is shown).

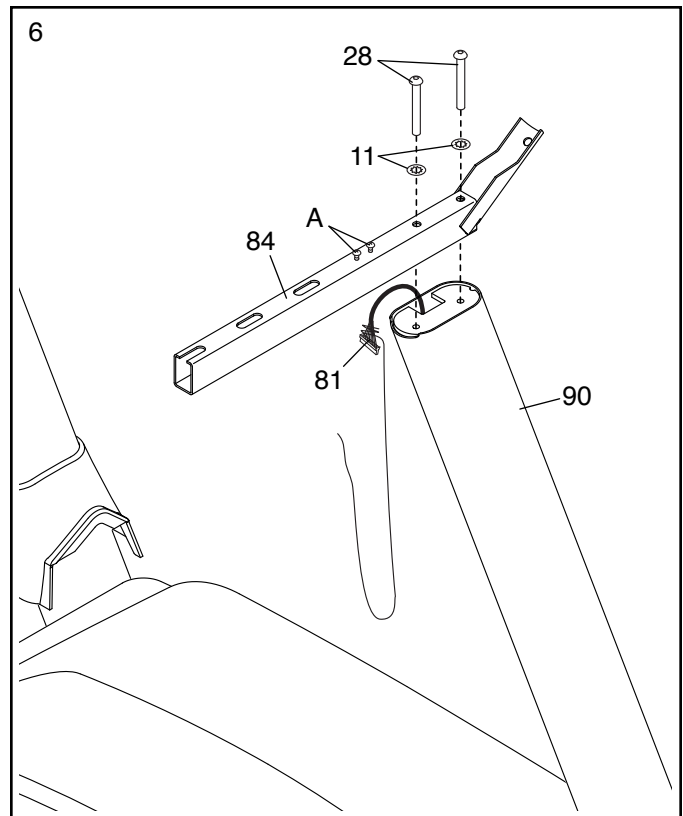

7. Set the console assembly face down on a soft surface to avoid scratching the console assembly. **Remove and save the four 1/4" x 1/2" Screws (2).**

Identify the Left Tray (36) with the writing on the bottom. Attach the Left Tray with four #8 x 1/2" Screws (1). Start all four Screws, and then tighten them. **Be careful not to overtighten the Screws.**

Attach the Right Tray (27) in the same way.

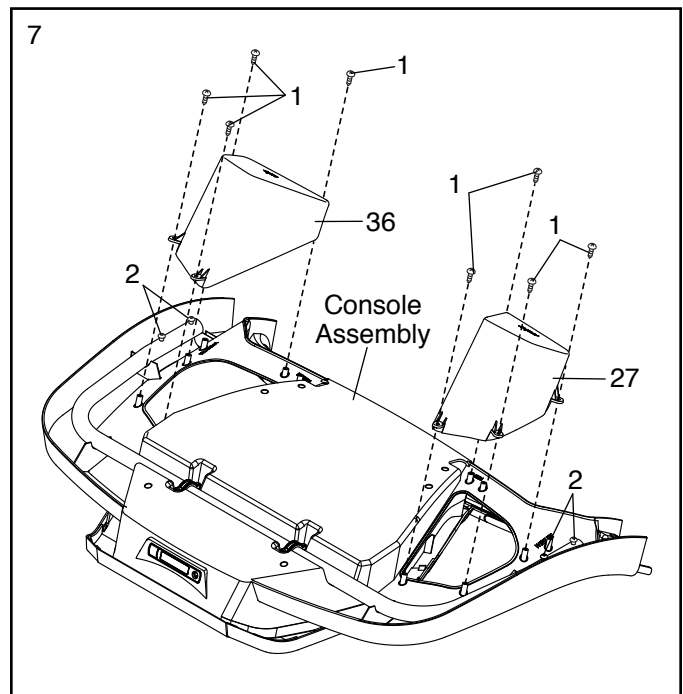

8. With the help of a second person, hold the console assembly near the Handrails (84) (only one side is shown).

See the inset drawing. Connect the Upright Wire (81) to the console wire. **The connectors should slide together easily and snap into place.** If they do not, turn one connector and try again. **IF YOU DO NOT CONNECT THE CONNECTORS PROPERLY, THE CONSOLE MAY BECOME DAMAGED WHEN YOU TURN ON THE POWER.** Then, remove the wire tie from the Upright Wire.

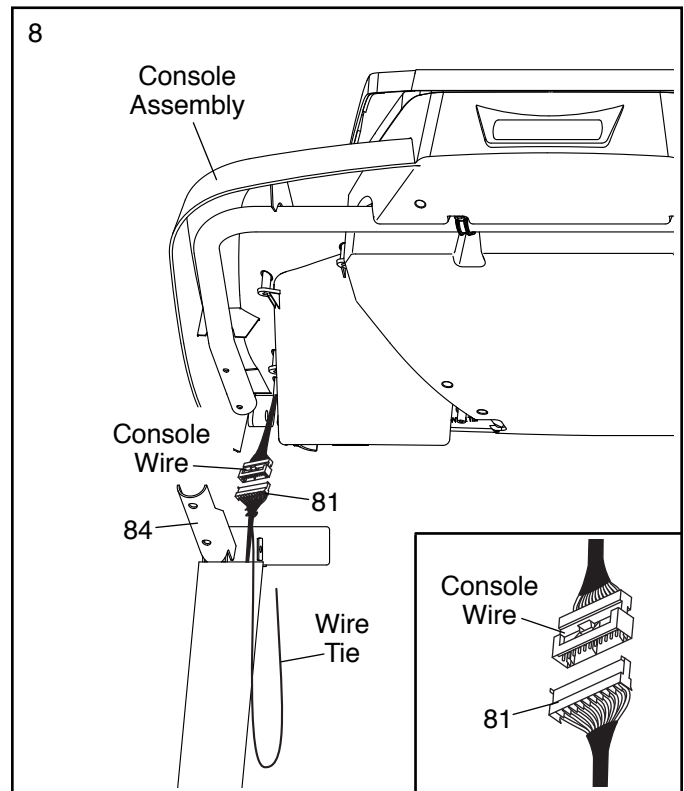

9. Set the console assembly on the Handrails (84). **Be careful not to pinch any wires.** Insert the excess Upright Wire (81) into the Right Upright (90).

Attach the console assembly with the four 1/4" x 1/2" Screws (2) removed in step 7 and four 1/4" Star Washers (26); **do not tighten the Screws yet.**

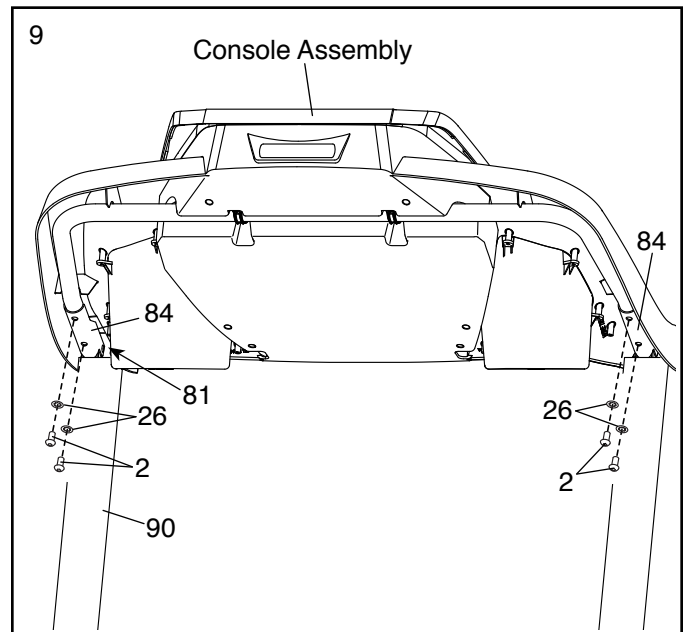

10. **IMPORTANT:** To avoid damaging the Pulse Crossbar (5), do not use power tools and do not overtighten the #10 x 3/4" Screws (9).

Tighten four #10 x 3/4" Screws (9) with four 1/4" Star Washers (26) into the Pulse Crossbar (5) and the Handrails (84). **Start all four Screws, and then tighten them.**

See step 9. Tighten the four 1/4" x 1/2" Screws (2).

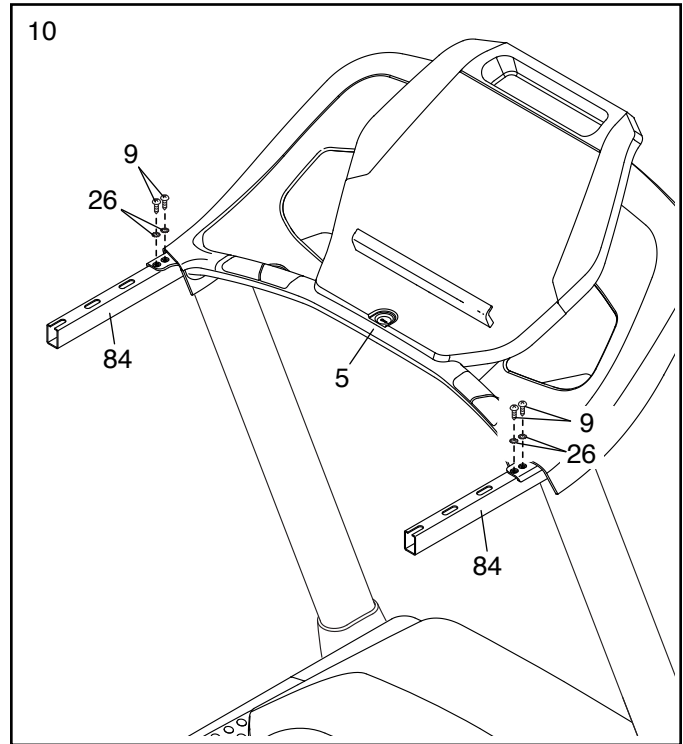

11. Identify the Left and Right Handrail Inserts (79, 31).

Attach the Left Handrail Insert (79) to the left Handrail (84) with three #8 x 3/4" Screws (4). **Slide the Left Handrail Insert against the console assembly, and then tighten the Screws.**

Attach the Right Handrail Insert (31) in the same way.

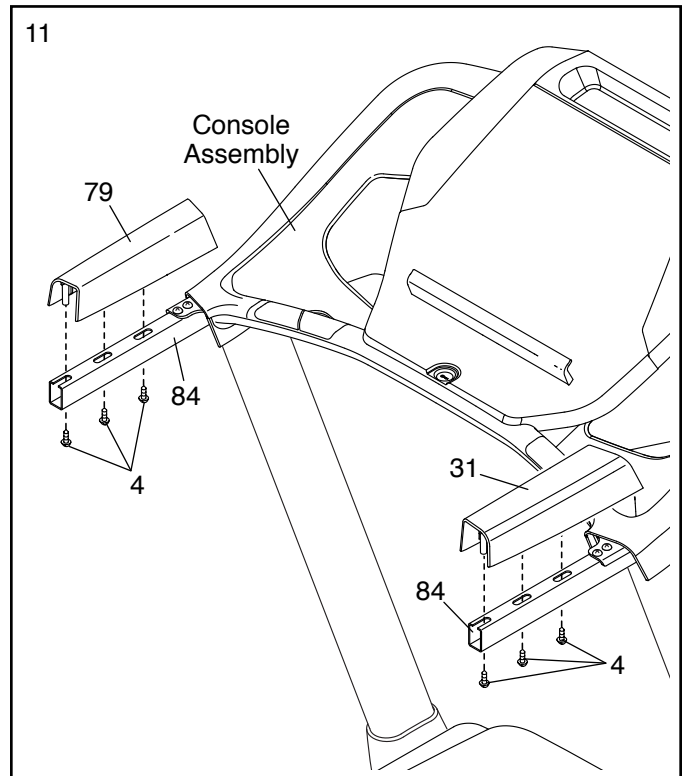

12. Identify the Left and Right Handrail Covers (87, 8).

Slide the Left Handrail Cover (87) up against the console assembly and tighten a #8 x 3/4" Screw (4) into the bottom of the Left Handrail Cover. **Be careful not to overtighten the Screw.**

Attach the Right Handrail Cover (8) in the same way.

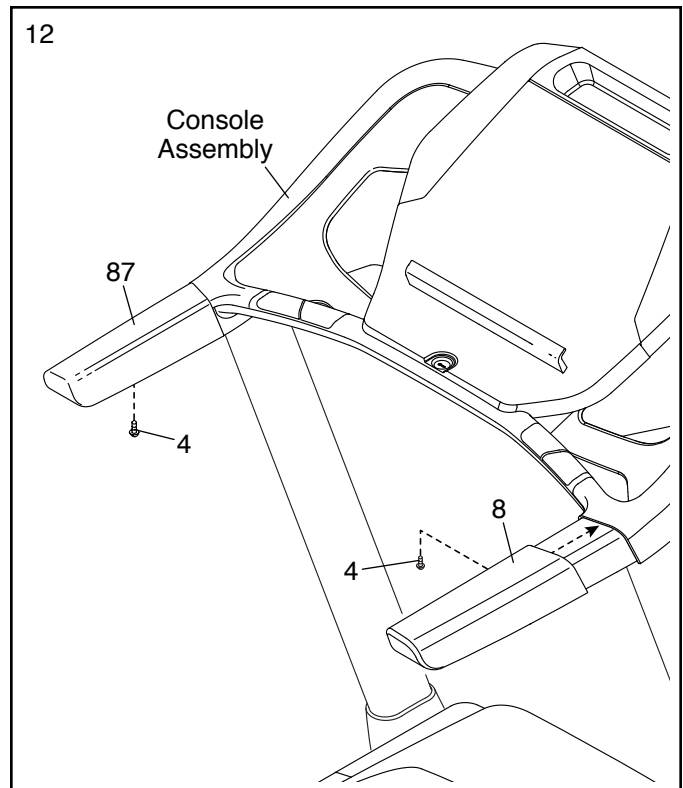

13. **Note: If it is assembled on a smooth surface, the treadmill may roll forward during this step.**

Raise the Frame (56) to the upright position. **Have a second person hold the Frame until step 15 is completed.**

Orient the Latch Crossbar (97) as shown. **Make sure that the "This side toward belt" sticker (B) is facing the treadmill.** Attach the Latch Crossbar to the brackets on the Frame (56) with two 5/16" x 3/4" Screws (93).

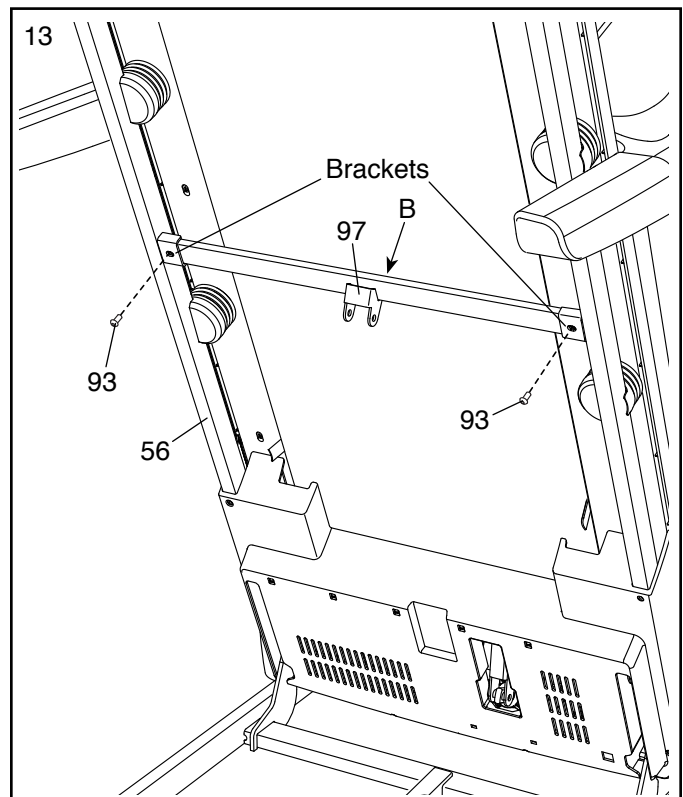

14. Orient the Storage Latch (96) so that the decals are facing away from the treadmill as shown.

Attach the lower end of the Storage Latch (96) to the bracket on the Base (85) with a 5/16" x 1 3/4" Bolt (94), two Latch Spacers (98), and a 5/16" Nut (34) as shown.

Raise the Storage Latch (96) to a vertical position. If a tie and a spacer (C) are in the top of the latch, remove and discard them.

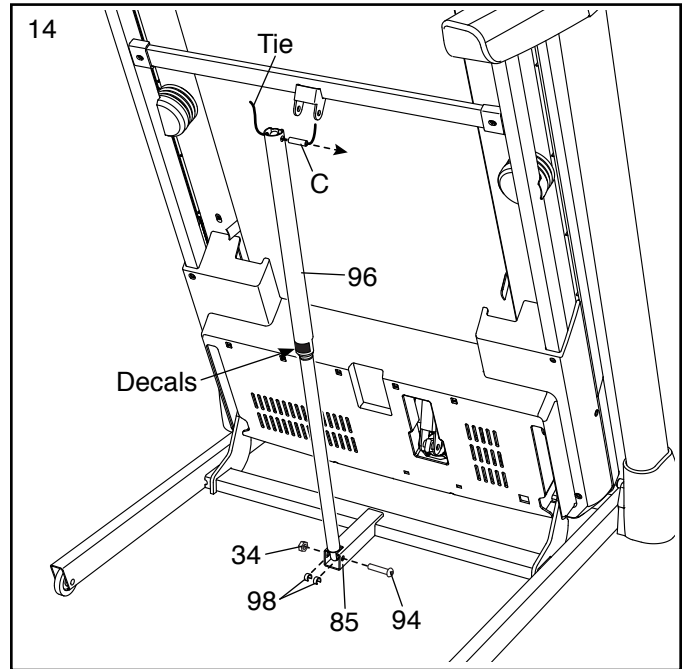

15. Attach the upper end of the Storage Latch (96) to the bracket on the Latch Crossbar (97) with a 5/16" x 2 1/4" Shoulder Bolt (95) and a 5/16" Nut (34).

Lower the Frame (56) (see HOW TO LOWER THE TREADMILL FOR USE on page 22).

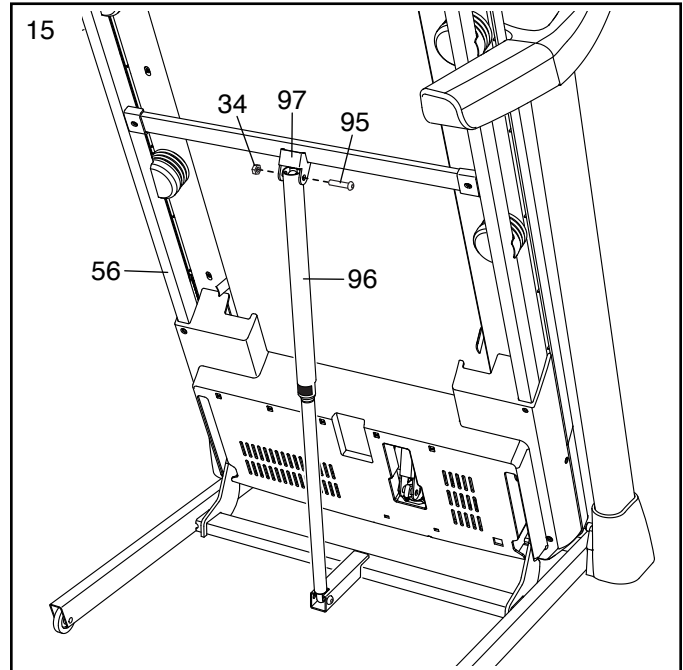

16. Firmly tighten all six 3/8" x 4" Screws (7). Then, slide the Left and Right Base Covers (82, 83) downward.

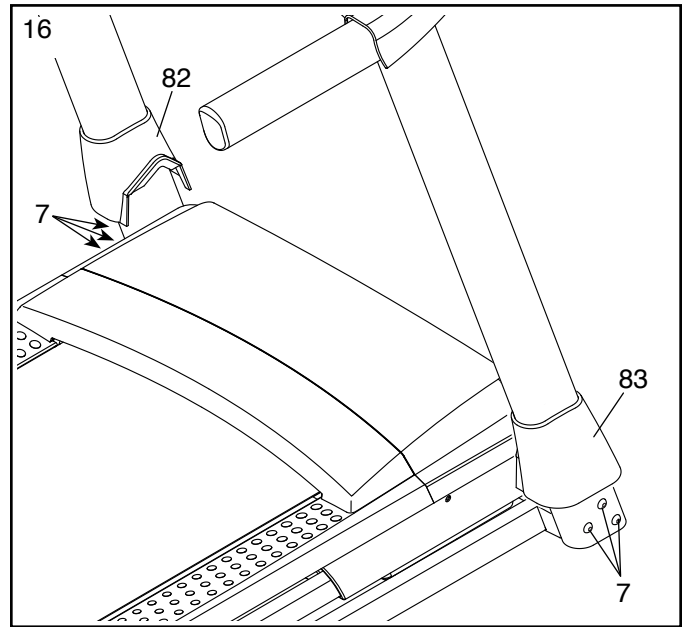

17. **Make sure that all parts are properly tightened before you use the treadmill.** If there are sheets of plastic on the treadmill decals, remove the plastic. To protect the floor or carpet, place a mat under the treadmill. To avoid damage to the console, keep the treadmill out of direct sunlight. Keep the included hex key in a secure place; the hex key is used to adjust the walking belt (see pages 24 and 25). Note: Extra hardware may be included.

HOW TO USE THE TREADMILL

HOW TO PLUG IN THE POWER CORD

This product must be earthed. If it should malfunction or break down, earthing provides a path of least resistance for electric current to reduce the risk of electric shock. This product's power cord has an equipment-earthing conductor and an earthing plug. **IMPORTANT: If the power cord is damaged, it must be replaced with a manufacturer-recommended power cord.**

⚠ DANGER: Improper connection of the equipment-earthing conductor can result in an increased risk of electric shock. Check with a qualified electrician or serviceman if you are in doubt as to whether the product is properly earthed. Do not modify the plug provided with the product—if it will not fit the outlet, have a proper outlet installed by a qualified electrician.

Follow the steps below to plug in the power cord.

1. Plug the indicated end of the power cord into the socket on the treadmill.

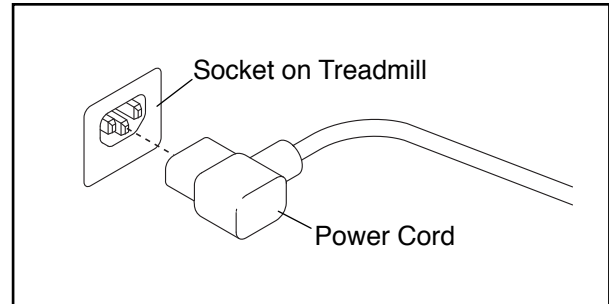

2. Plug the power cord into an appropriate outlet that is properly installed and earthed in accordance with all local codes and ordinances.

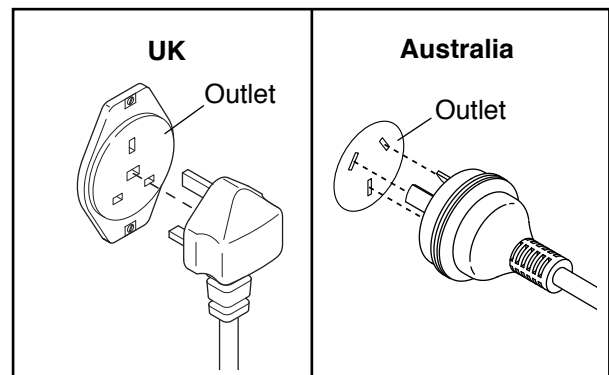

CONSOLE DIAGRAM

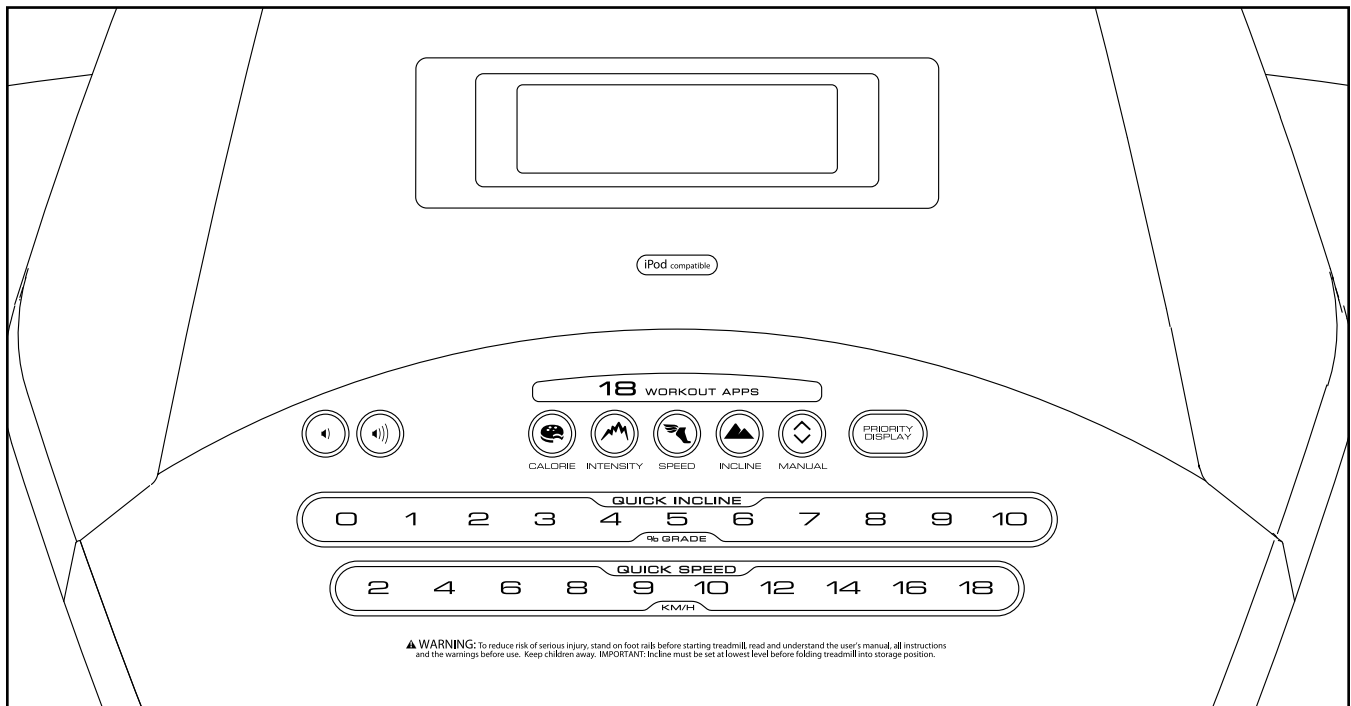

FEATURES OF THE CONSOLE

The treadmill console offers an impressive array of features designed to make your workouts more effective and enjoyable. When you use the manual mode, you can change the speed and incline of the treadmill with the touch of a button. As you exercise, the console will display instant exercise feedback. You can even measure your heart rate using the handgrip heart rate monitor or the optional chest heart rate monitor.

In addition, the console features a selection of onboard workouts. Each workout automatically controls the speed and incline of the treadmill as it guides you through an effective exercise session.

You can even listen to your favorite workout music or audio books with the console's sound system while you exercise.

To turn on the power, see page 18. To use the manual mode, see page 18. To use an onboard workout, see page 20. To use the information mode, see page 21. To use the sound system, see page 21.

Note: The console can display speed and distance in either miles or kilometers. To find which unit of measurement is selected, see THE INFORMATION MODE on page 21. For simplicity, all instructions in this manual refer to kilometers.

IMPORTANT: If there are sheets of plastic on the console, remove the plastic. To prevent damage to the walking platform, wear clean athletic shoes while using the treadmill. The first time you use the treadmill, observe the alignment of the walking belt, and center the walking belt if necessary (see page 25).

HOW TO TURN ON THE POWER

IMPORTANT: If the treadmill has been exposed to cold temperatures, allow it to warm to room temperature before you turn on the power. If you do not do this, you may damage the console displays or other electrical components.

Plug in the power cord (see page 16). Next, locate the power switch on the treadmill frame near the power cord. Press the power switch into the reset position.

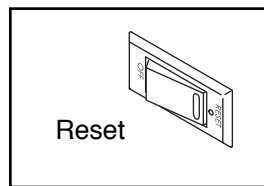

IMPORTANT: The console features a display demo mode, designed to be used if the treadmill is displayed in a store. If the displays light as soon as you plug in the power cord and press the power switch into the reset position, the demo mode is turned on. To turn off the demo mode, hold down the Stop button for a few seconds. If the displays remain lit, see THE INFORMATION MODE on page 21 to turn off the demo mode.

Next, stand on the foot rails of the treadmill. Find the clip attached to the key, and slide the clip onto the waistband of your clothes. Then, insert the key into the console. After a moment, the displays will light. **IMPORTANT:** In an emergency, the key can be pulled from the console, causing the walking belt to slow to a stop. Test the clip by carefully taking a few steps backward; if the key is not pulled from the console, adjust the position of the clip.

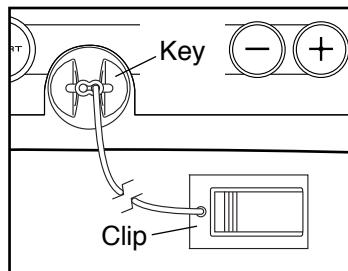

HOW TO USE THE MANUAL MODE

1. Insert the key into the console.

See HOW TO TURN ON THE POWER at the left.

2. Select the manual mode.

When the key is inserted, the manual mode will be selected. If an onboard workout has been selected, remove the key and then reinsert it.

3. Start the walking belt.

To start the walking belt, press the Start button, the Speed increase button, or one of the Quick Speed buttons numbered 2 through 18.

If you press the Start button or the Speed increase button, the walking belt will begin to move at 2 Km/H. As you exercise, change the speed of the walking belt as desired by pressing the Speed increase and decrease buttons. Each time you press one of the buttons, the speed setting will change by 0.1 Km/H; if you hold down the button, the speed setting will change in increments of 0.5 Km/H. Note: After you press the button, it may take a moment for the walking belt to reach the selected speed setting.

If you press one of the numbered Quick Speed buttons, the walking belt will gradually change speed until it reaches the selected speed setting.

To stop the walking belt, press the Stop button. The time will begin to flash in the display. To restart the walking belt, press the Start button or the Speed increase button.

4. Change the incline of the treadmill as desired.

To change the incline of the treadmill, press the Incline increase or decrease button or one of the Quick Incline buttons numbered 0 through 10. Each time you press one of the buttons, the treadmill will gradually adjust to the selected incline setting.

5. Follow your progress with the displays.

When you select the manual mode, a track representing 400 m (1/4 mile) will appear in the matrix. As you walk or run on the treadmill, the indicators around the track will appear in succession until the entire track appears. The track will then disappear and the indicators will again begin to appear in succession.

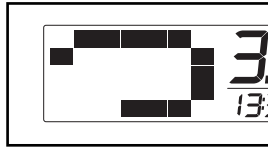

The lower left display can show the elapsed time and the distance that you have walked or run during your workout. Each time you change the incline, the display will show the incline setting for a few seconds. Note: When a workout is selected, the display will show the time remaining in the workout instead of the elapsed time.



The lower right display can show the speed of the walking belt and the approximate number of calories that you have burned during your workout. The display will also show your heart rate when you use the handgrip heart rate monitor (see step 6).



The upper display can show the elapsed time, the distance that you have walked or run, the approximate number of calories you have burned, or the speed of the walking belt. Press the Priority Display button repeatedly until the upper display shows the information that you are most interested in viewing. Note: While information is shown in the upper display, the same information will not be shown in the lower left or lower right display.

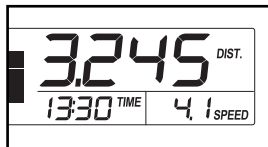

To reset the displays, press the Stop button, remove the key, and then reinsert the key.

6. Measure your heart rate if desired.

Note: If you use the handgrip heart rate monitor and the optional chest heart rate monitor at the same time, the console will not display your heart rate accurately. To purchase the chest heart rate monitor, see page 21.

Before using the handgrip heart rate monitor, remove the sheets of plastic from the metal contacts. In addition, make sure that your hands are clean.

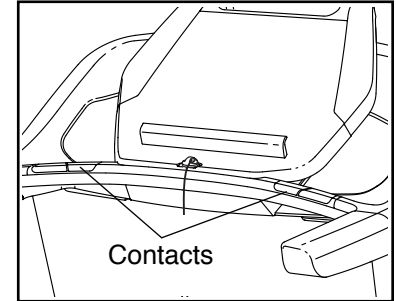

To measure your heart rate, **stand on the foot rails** and place your hands on the metal contacts—**avoid moving your hands**. When your pulse is detected, your heart rate will be shown. **For the most accurate heart rate reading, continue to hold the contacts for about 15 seconds.**

7. When you are finished exercising, remove the key from the console.

Step onto the foot rails, press the Stop button, and **adjust the incline of the treadmill to zero**. **The incline must be at zero when you fold the treadmill to the storage position, or you may damage the treadmill.** Next, remove the key from the console and put it in a secure place.

When you are finished using the treadmill, press the power switch into the off position and unplug the power cord. **IMPORTANT: If you do not do this, the treadmill's electrical components may wear prematurely.**

HOW TO USE AN ONBOARD WORKOUT

1. Insert the key into the console.

See HOW TO TURN ON THE POWER on page 18.

2. Select an onboard workout.

To select an onboard workout, press the Calorie button, the Intensity button, the Speed button, or the Incline button repeatedly until the desired workout appears in the display.

When you select an onboard workout, the displays will show the maximum incline, the duration, the maximum speed, and the name of the workout. In addition, a profile of the speed settings of the workout will appear in the matrix. If you select a calorie workout, the approximate number of calories you will burn will appear in the name of the workout.

3. Start the workout.

Press the Start button or the Speed increase button to start the workout. A moment after you press the button, the treadmill will automatically adjust to the first speed and incline settings of the workout. Hold the handrails and begin walking. Note: If you select a speed workout, the exercise session will begin with a three-minute warm-up segment before the speed workout begins.

Each workout is divided into segments. One speed setting and one incline setting are programmed for each segment. Note: The same speed setting and/or incline setting may be programmed for consecutive segments.

During the workout, the profile will show your progress. The flashing segment of the profile represents the current segment of the workout. The height of the flashing segment indicates the speed setting for the current segment. At the end of each segment, a series of tones will sound and the next segment of the profile will begin to flash. If a new speed and/or incline setting is programmed for the next segment, the new speed

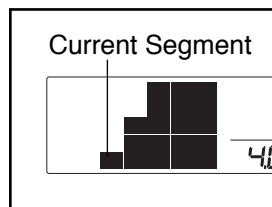

and/or incline setting will appear in the displays for a few seconds and the treadmill will automatically adjust to the new speed and/or incline setting.

The workout will continue in this way until the last segment of the profile flashes in the display and the last segment ends. The walking belt will then slow to a stop.

Note: The calorie goal is an estimate of the number of calories that you will burn during the workout. The actual number of calories that you burn will depend on various factors such as your weight. In addition, if you manually change the speed or incline of the treadmill during the workout, the number of calories you burn will be affected.

If the speed or incline setting is too high or too low at any time during the workout, you can manually override the setting by pressing the Speed or Incline buttons; **however, when the next segment of the workout begins, the treadmill will automatically adjust to the speed and incline settings for the next segment.**

To stop the workout at any time, press the Stop button. The time will begin to flash in the display. To resume the workout, press the Start button or the Speed increase button. The walking belt will begin to move at 2 Km/H. When the next segment of the workout begins, the treadmill will automatically adjust to the speed and incline settings for the next segment.

4. Follow your progress with the displays.

See step 5 on page 19. The display will show the time remaining instead of the elapsed time.

5. Measure your heart rate if desired.

See step 6 on page 19.

6. When you are finished exercising, remove the key from the console.

See step 7 on page 19.

THE INFORMATION MODE

The console features an information mode that keeps track of treadmill usage information and allows you to select a unit of measurement for the console. You can also turn on and turn off the display demo mode.

To select the information mode, insert the key into the console while holding down the Stop button. Then, release the Stop button. When the information mode is selected, the following information will be shown:

The upper display will show the total number of hours that the treadmill has been used.

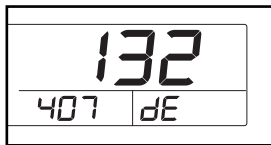

The lower left display will show the total number of kilometers or miles that the walking belt has moved.

An “E” for English miles or an “M” for metric kilometers will appear in the lower right display. Press the Speed increase button to change the unit of measurement, if desired.

The console features a display demo mode, designed to be used if the treadmill is displayed in a store. While the demo mode is turned on, the console will function normally when you plug in the power cord, press the power switch into the reset position, and insert the key into the console. However, when you remove the key, the displays will remain lit, although the buttons will not function. If the demo mode is turned on, a “d” will appear in the lower right display while the information mode is selected. To turn on or turn off the demo mode, press the Speed decrease button.

To exit the information mode, remove the key from the console.

HOW TO USE THE SOUND SYSTEM

To play music or audio books through the console sound system while you exercise, plug a 3.5 mm male to 3.5 mm male audio cable (not included) into the jack on the console and into a jack on your MP3 player, CD player, or other personal audio player; **make sure that the audio cable is fully plugged in. Note: To purchase an audio cable, see your local electronics store.**

Next, press the play button on your personal audio player. Adjust the volume level using the volume increase and decrease buttons on the console or the volume control on your personal audio player.

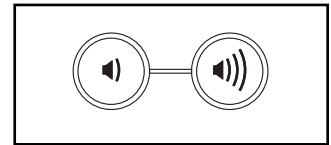

If you are using a personal CD player and the CD skips, set the CD player on the floor or another flat surface instead of on the console.

THE OPTIONAL CHEST HEART RATE MONITOR

Whether your goal is to burn fat or to strengthen your cardiovascular system, the key to achieving the best results is to maintain the proper heart rate during your workouts.

The optional chest heart rate monitor will enable you to continuously monitor your heart rate while you exercise, helping you to reach your personal fitness goals. **To purchase a chest heart rate monitor, please see the front cover of this manual.**

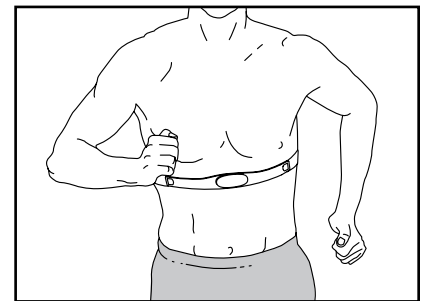

HOW TO FOLD AND MOVE THE TREADMILL

HOW TO FOLD THE TREADMILL

To avoid damaging the treadmill, adjust the incline to zero before you fold the treadmill. Then, remove the key and unplug the power cord. **CAUTION:** You must be able to safely lift 45 lbs. (20 kg) to raise, lower, or move the treadmill.

1. Hold the metal frame firmly in the location shown by the arrow below. **CAUTION:** Do not hold the frame by the plastic foot rails. Bend your legs and keep your back straight as you raise the frame about halfway to the vertical position.

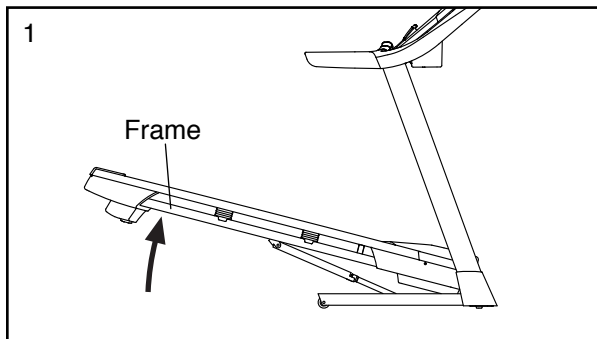

2. Raise the frame until the storage latch locks in the storage position. **CAUTION:** Make sure that the storage latch locks.

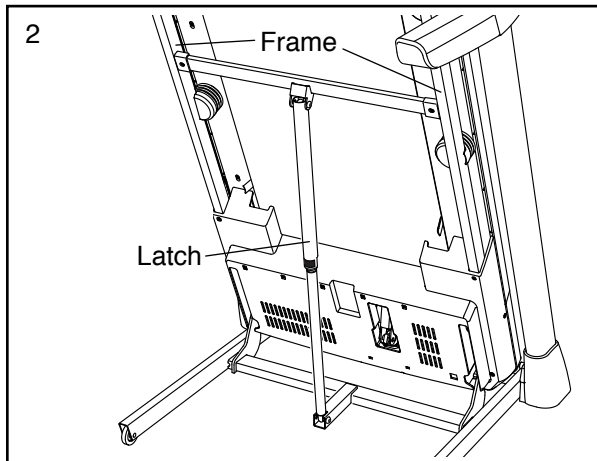

To protect the floor or carpet, place a mat under the treadmill. Keep the treadmill out of direct sunlight. Do not leave the treadmill in the storage position in temperatures above 85° F (30° C).

HOW TO MOVE THE TREADMILL

Before moving the treadmill, fold it as described at the left. **CAUTION:** Make sure that the latch knob is locked in the storage position. Moving the treadmill may require two people.

1. Hold the frame and one of the handrails, and place one foot against a wheel.

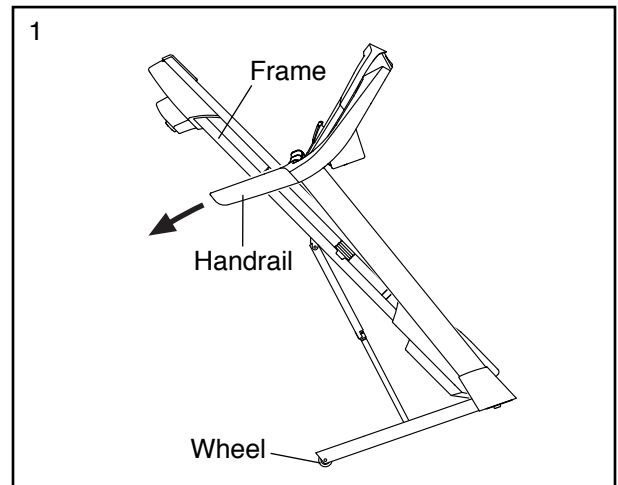

2. Pull back on the handrail until the treadmill will roll on the wheels, and carefully move it to the desired location. **CAUTION:** Do not move the treadmill without tipping it back, do not pull on the frame, and do not move the treadmill over an uneven surface.
3. Place one foot against a wheel, and carefully lower the treadmill.

HOW TO LOWER THE TREADMILL FOR USE

1. Press on the upper end of the treadmill frame with your hands, press the storage latch with your foot in the location shown, and then allow the frame to lower to the floor.

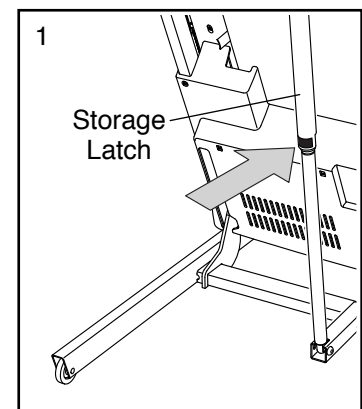

MAINTENANCE AND TROUBLESHOOTING

MAINTENANCE

Regularly clean the treadmill and keep the walking belt clean and dry. First, **press the power switch into the off position and unplug the power cord**. Wipe exterior parts of the treadmill with a damp cloth and a small amount of mild soap. **IMPORTANT: Do not spray liquids directly onto the treadmill. To avoid damage to the console, keep liquids away from the console.** Then, thoroughly dry the treadmill with a soft towel.

TROUBLESHOOTING

Most treadmill problems can be solved by following the simple steps below. Find the symptom that applies, and follow the steps listed. If further assistance is needed, see the front cover of this manual.

SYMPTOM: The power does not turn on

- Make sure that the power cord is plugged into a properly earthed outlet (see page 16). If an extension cord is needed, use only a 3-conductor, 14-gauge (1 mm²) cord that is no longer than 5 ft. (1.5 m).
- After the power cord has been plugged in, make sure that the key is inserted into the console.
- Check the power switch located on the treadmill frame near the power cord. If the switch protrudes as shown, the switch has tripped. To reset the power switch, wait for five minutes and then press the switch back in.

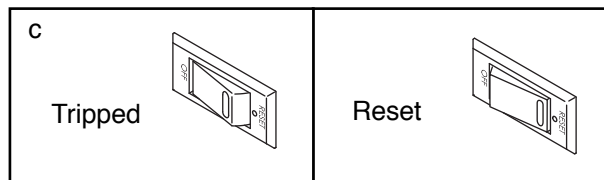

SYMPTOM: The power turns off during use

- Check the power switch (see drawing c at the left). If the switch has tripped, wait for five minutes and then press the switch back in.
- Make sure that the power cord is plugged in. If the power cord is plugged in, unplug it, wait for five minutes, and then plug it back in.
- Remove the key from the console, and then reinsert it.
- If the treadmill still will not run, please see the front cover of this manual.

SYMPTOM: The console displays remain lit when you remove the key from the console

- The console features a display demo mode, designed to be used if the treadmill is displayed in a store. If the displays remain lit when you remove the key, the demo mode is turned on. To turn off the demo mode, hold down the Stop button for a few seconds. If the displays are still lit, see THE INFORMATION MODE on page 21 to turn off the demo mode.

SYMPTOM: The displays of the console do not function properly

- Remove the key from the console and **UNPLUG THE POWER CORD**. Next, remove the five #8 x 3/4" Screws (4), and carefully pivot off the Motor Hood (65).

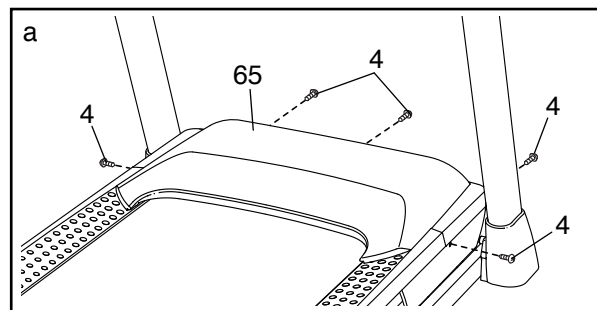

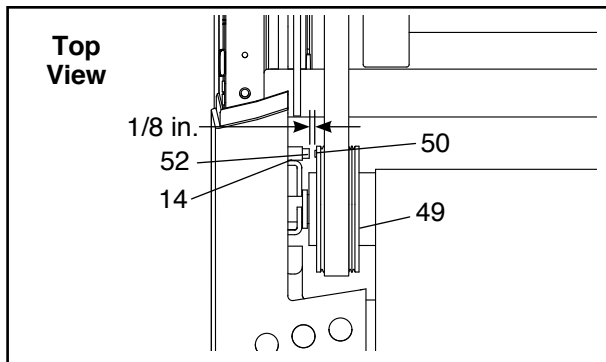

Next, locate the Reed Switch (52) and the Magnet (50) on the left side of the Pulley (49). Turn the Pulley until the Magnet is aligned with the Reed Switch. **Make sure that the gap between the Magnet and the Reed Switch is about 1/8 in. (3 mm).** If necessary, loosen the #8 x 3/4" Truss Head Screw (14), move the Reed Switch slightly, and then retighten the Screw. Reattach the Motor Hood (not shown), and run the treadmill for a few minutes to check for a correct speed reading.

SYMPTOM: The incline of the treadmill does not change correctly

- a. Hold down the Stop button and the Speed increase button, insert the key into the console, and then release the Stop button and the Speed increase button. Press the Stop button and then press the Incline increase or decrease button. The treadmill will automatically rise to the maximum incline level and then return to the minimum level. This will recalibrate the incline system. If the incline system does not begin calibrating, press the Stop button again, and then press the Incline increase or decrease button again. When the incline system is calibrated, remove the key from the console.

SYMPTOM: The walking belt slows when walked on

- a. If an extension cord is needed, use only a 3-conductor, 14-gauge (1 mm²) cord that is no longer than 5 ft. (1.5 m).

- b. If the walking belt is overtightened, treadmill performance may decrease and the walking belt may become damaged. Remove the key and **UNPLUG THE POWER CORD.** Using the hex key, turn both idler roller screws counterclockwise, 1/4 of a turn. When the walking belt is properly tightened, you should be able to lift each edge of the walking belt 2 to 3 in. (5 to 7 cm) off the walking platform. Be careful to keep the walking belt centered. Then, plug in the power cord, insert the key, and run the treadmill for a few minutes. Repeat until the walking belt is properly tightened.

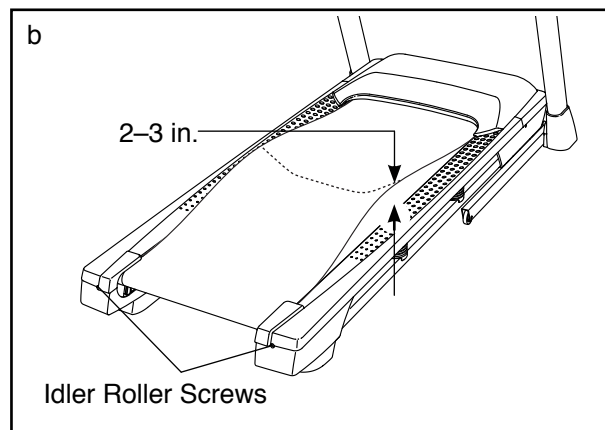

- c. Your treadmill features a walking belt coated with high-performance lubricant. **IMPORTANT: Never apply silicone spray or other substances to the walking belt or the walking platform unless instructed to do so by an authorized service representative. Such substances may deteriorate the walking belt and cause excessive wear.** If you suspect that the walking belt needs more lubricant, see the front cover of this manual.
- d. If the walking belt still slows when walked on, see the front cover of this manual.

SYMPTOM: The walking belt is off-center

IMPORTANT: The walking belt should be centered between the foot rails. If the walking belt rubs against the foot rails, the walking belt may become damaged.

- a. First, remove the key and **UNPLUG THE POWER CORD**. If the walking belt has shifted to the left, use the hex key to turn the left idler roller screw clockwise 1/2 of a turn; if the walking belt has shifted to the right, turn the left idler roller screw counterclockwise 1/2 of a turn. Be careful not to overtighten the walking belt. Then, plug in the power cord, insert the key, and run the treadmill for a few minutes. Repeat until the walking belt is centered.

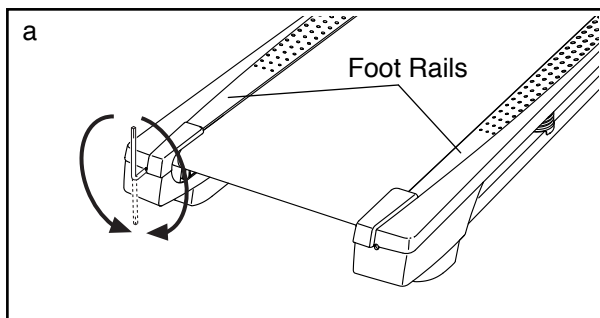

SYMPTOM: The walking belt slips when walked on

- a. First, remove the key and **UNPLUG THE POWER CORD**. Using the hex key, turn both idler roller screws clockwise, 1/4 of a turn. When the walking belt is correctly tightened, you should be able to lift each edge of the walking belt 2 to 3 in. (5 to 7 cm) off the walking platform. Be careful to keep the walking belt centered. Then, plug in the power cord, insert the key, and carefully walk on the treadmill for a few minutes. Repeat until the walking belt is properly tightened.

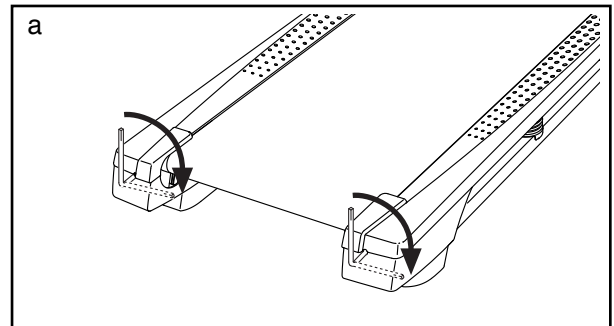

EXERCISE GUIDELINES

⚠️ WARNING: Before beginning this or any exercise program, consult your physician. This is especially important for persons over age 35 or persons with pre-existing health problems.

The heart rate monitor is not a medical device. Various factors may affect the accuracy of heart rate readings. The heart rate monitor is intended only as an exercise aid in determining heart rate trends in general.

These guidelines will help you to plan your exercise program. For detailed exercise information, obtain a reputable book or consult your physician. Remember, proper nutrition and adequate rest are essential for successful results.

EXERCISE INTENSITY

Whether your goal is to burn fat or to strengthen your cardiovascular system, exercising at the proper intensity is the key to achieving results. You can use your heart rate as a guide to find the proper intensity level. The chart below shows recommended heart rates for fat burning and aerobic exercise.

165	155	145	140	130	125	115	❤️
145	138	130	125	118	110	103	❤️
125	120	115	110	105	95	90	❤️
<hr/>							
20	30	40	50	60	70	80	

To find the proper intensity level, find your age at the bottom of the chart (ages are rounded off to the nearest ten years). The three numbers listed above your age define your “training zone.” The lowest number is the heart rate for fat burning, the middle number is the heart rate for maximum fat burning, and the highest number is the heart rate for aerobic exercise.

Burning Fat—To burn fat effectively, you must exercise at a low intensity level for a sustained period of time. During the first few minutes of exercise, your body uses carbohydrate calories for energy. Only after the first few minutes of exercise does your body begin to use stored fat calories for energy. If your goal is to burn fat, adjust the intensity of your exercise until your heart rate is near the lowest number in your training zone. For maximum fat burning, exercise with your heart rate near the middle number in your training zone.

Aerobic Exercise—If your goal is to strengthen your cardiovascular system, you must perform aerobic exercise, which is activity that requires large amounts of oxygen for prolonged periods of time. For aerobic exercise, adjust the intensity of your exercise until your heart rate is near the highest number in your training zone.

WORKOUT GUIDELINES

Warming Up—Start with 5 to 10 minutes of stretching and light exercise. A warm-up increases your body temperature, heart rate, and circulation in preparation for exercise.

Training Zone Exercise—Exercise for 20 to 30 minutes with your heart rate in your training zone. (During the first few weeks of your exercise program, do not keep your heart rate in your training zone for longer than 20 minutes.) Breathe regularly and deeply as you exercise; never hold your breath.

Cooling Down—Finish with 5 to 10 minutes of stretching. Stretching increases the flexibility of your muscles and helps to prevent post-exercise problems.

EXERCISE FREQUENCY

To maintain or improve your condition, complete three workouts each week, with at least one day of rest between workouts. After a few months of regular exercise, you may complete up to five workouts each week, if desired. Remember, the key to success is to make exercise a regular and enjoyable part of your everyday life.

PART LIST

Model No. PETL80914.1 R0414A

Key No.	Qty.	Description	Key No.	Qty.	Description
1	8	#8 x 1/2" Screw	51	1	Reed Switch Clip
2	4	1/4" x 1/2" Screw	52	1	Reed Switch
3	2	Base Pad	53	2	1/4" x 1 1/4" Screw
4	35	#8 x 3/4" Screw	54	1	Drive Motor
5	1	Pulse Crossbar	55	1	Motor Belt
6	1	Filter	56	1	Frame
7	6	3/8" x 4" Screw	57	1	Left Rear Foot
8	1	Right Handrail Cover	58	1	Console Ground Wire
9	4	#10 x 3/4" Screw	59	4	Rubber Cushion
10	11	#8 x 1/2" Silver Screw	60	1	Right Foot Rail
11	4	5/16" Star Washer	61	1	Idler Roller
12	4	#8 x 1" Tek Screw	62	1	Motor Plate
13	6	3/8" Star Washer	63	1	Motor Bushing
14	15	#8 x 3/4" Truss Head Screw	64	1	Console Base
15	2	1/4" x 2 1/2" Screw	65	1	Motor Hood
16	1	3/8" x 1 1/2" Bolt	66	4	Cushion Bottom
17	2	3/8" x 1 1/2" Wheel Bolt	67	2	Incline Frame Spacer
18	1	Console Frame	68	5	Hood Clip
19	4	#8 x 7/16" Screw	69	1	Incline Motor
20	2	5/16" Motor Screw	70	1	Incline Frame
21	2	3/8" Pin	71	2	Frame Spacer
22	2	3/8" x 1" Bolt	72	1	Controller
23	4	5/16" x 1 3/4" Shoulder Bolt	73	1	Controller Plate
24	2	#8 Star Washer	74	2	Base Cap
25	4	#8 x 1" Screw	75	1	Power Switch
26	8	1/4" Star Washer	76	1	Power Cord
27	1	Right Tray	77	2	Grommet
28	4	5/16" x 2 1/4" Screw	78	1	Belly Pan
29	1	3/8" x 1 3/4" Hex Head Bolt	79	1	Left Handrail Insert
30	4	5/16" Flat Washer	80	1	Console
31	1	Right Handrail Insert	81	1	Upright Wire
32	2	Incline Motor Spacer	82	1	Left Base Cover
33	6	3/8" Jam Nut	83	1	Right Base Cover
34	6	5/16" Nut	84	2	Handrail
35	4	1/4" x 1 1/4" Screw	85	1	Base
36	1	Left Tray	86	2	Wire Tie
37	6	#8 x 5/8" Screw	87	1	Left Handrail Cover
38	2	Wheel	88	1	Key/Clip
39	4	Isolator	89	1	Left Upright
40	2	Rear Foot	90	1	Right Upright
41	1	Receptacle	91	2	Warning Decal
42	1	Left Foot Rail	92	2	Console Clamp
43	1	Caution Decal	93	2	5/16" x 3/4" Screw
44	1	Walking Platform	94	1	5/16" x 1 3/4" Bolt
45	1	Walking Belt	95	1	5/16" x 2 1/4" Shoulder Bolt
46	2	Belt Guide	96	1	Storage Latch
47	1	Right Rear Foot	97	1	Latch Crossbar
48	4	Cable Tie	98	2	Latch Spacer
49	1	Drive Roller/Pulley	*	-	User's Manual
50	1	Magnet			

Note: Specifications are subject to change without notice. For information about ordering replacement parts, see the back cover of this manual. *These parts are not illustrated.

EXPLODED DRAWING A

Model No. PETL80914.1 R0414A

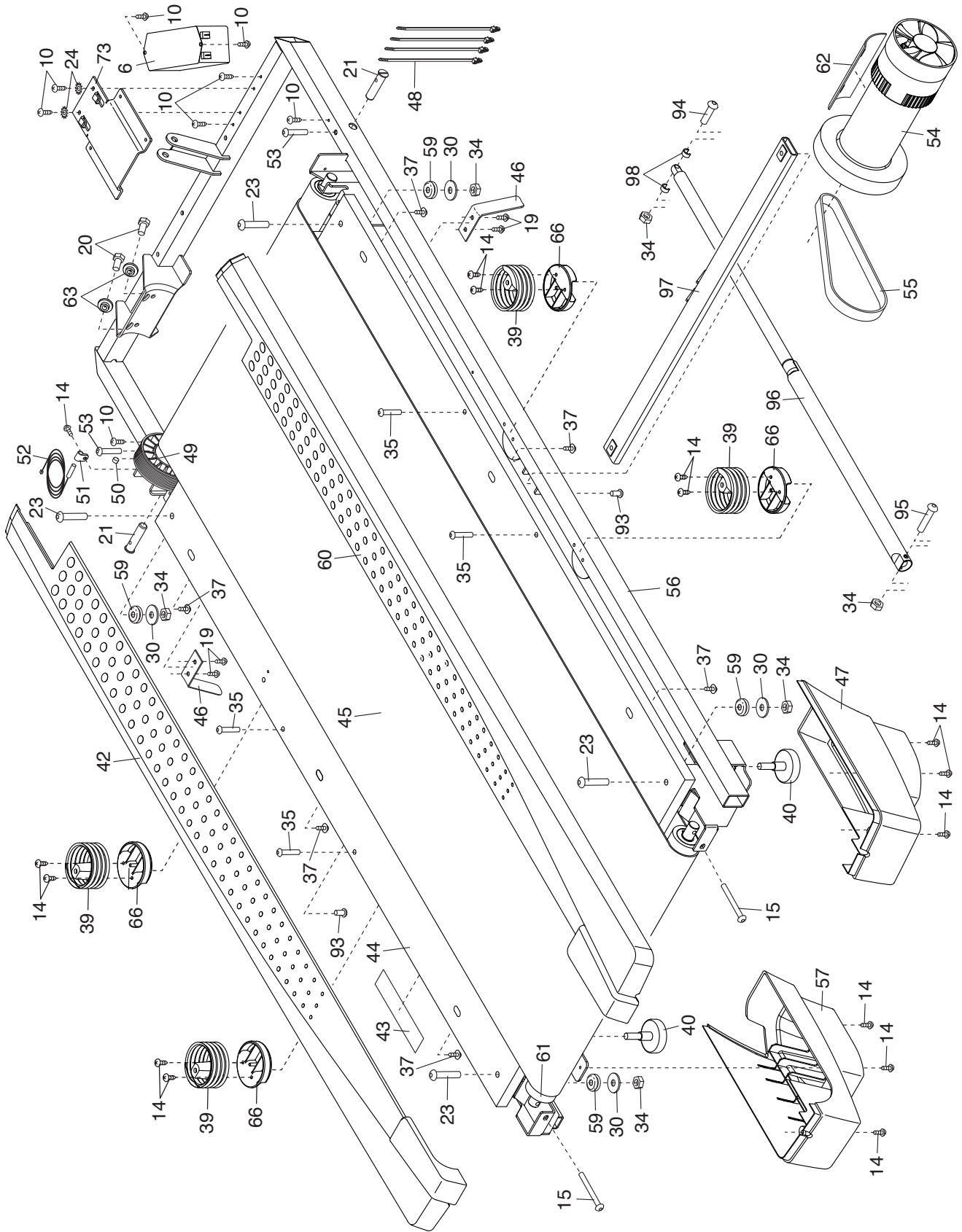

EXPLODED DRAWING B

Model No. PETL80914.1 R0414A

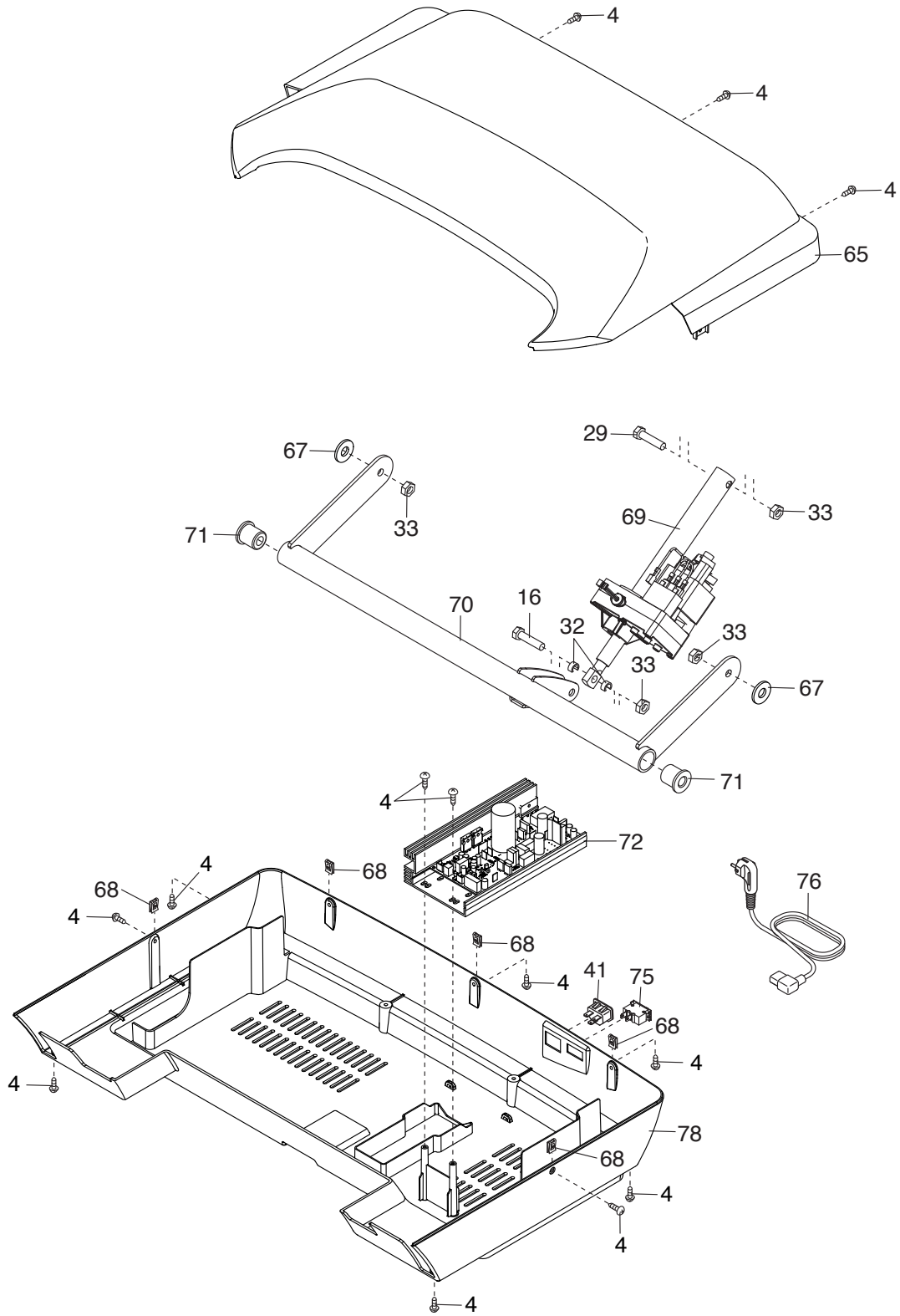

EXPLODED DRAWING C

Model No. PETL80914.1 R0414A

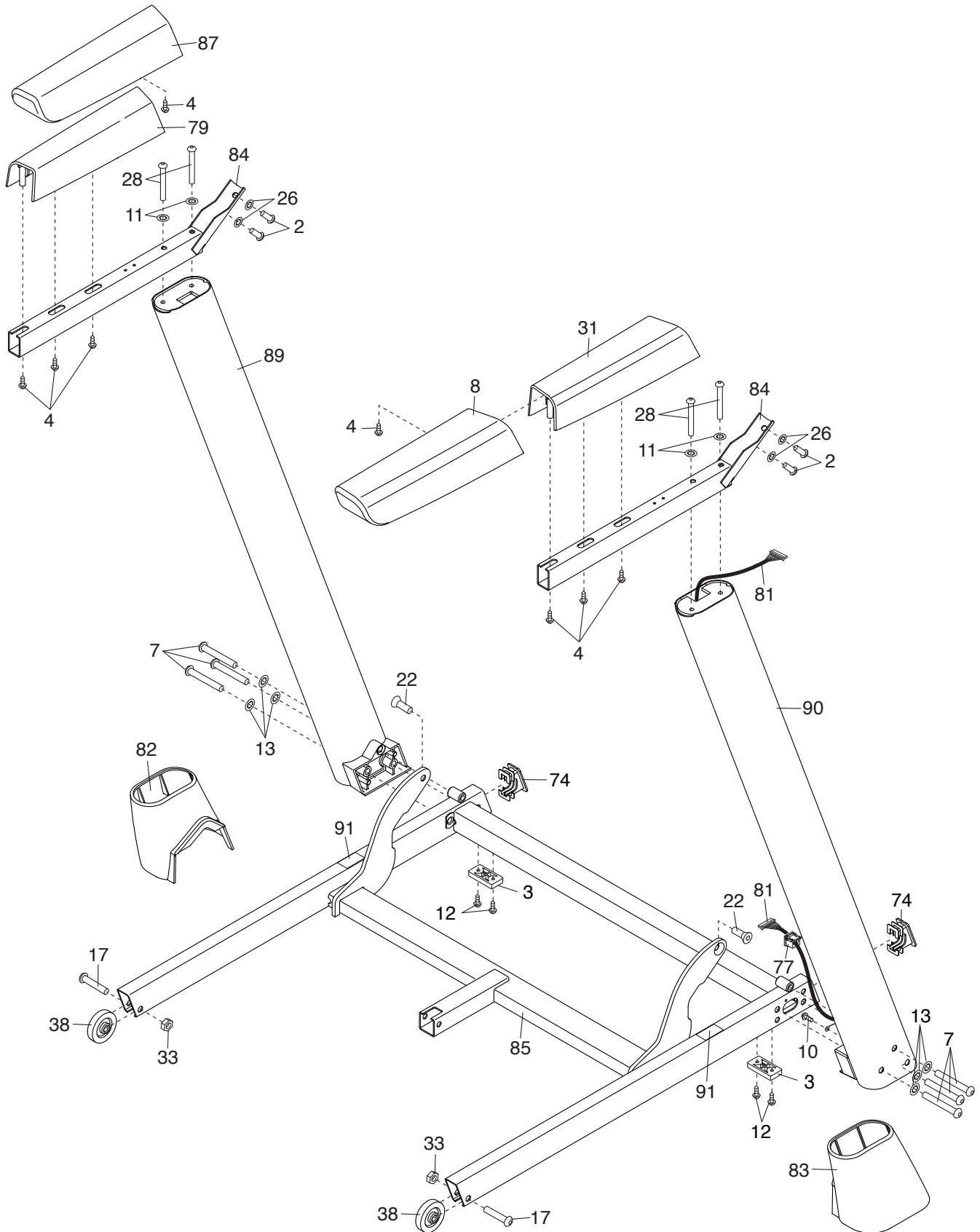

EXPLODED DRAWING D

Model No. PETL80914.1 R0414A

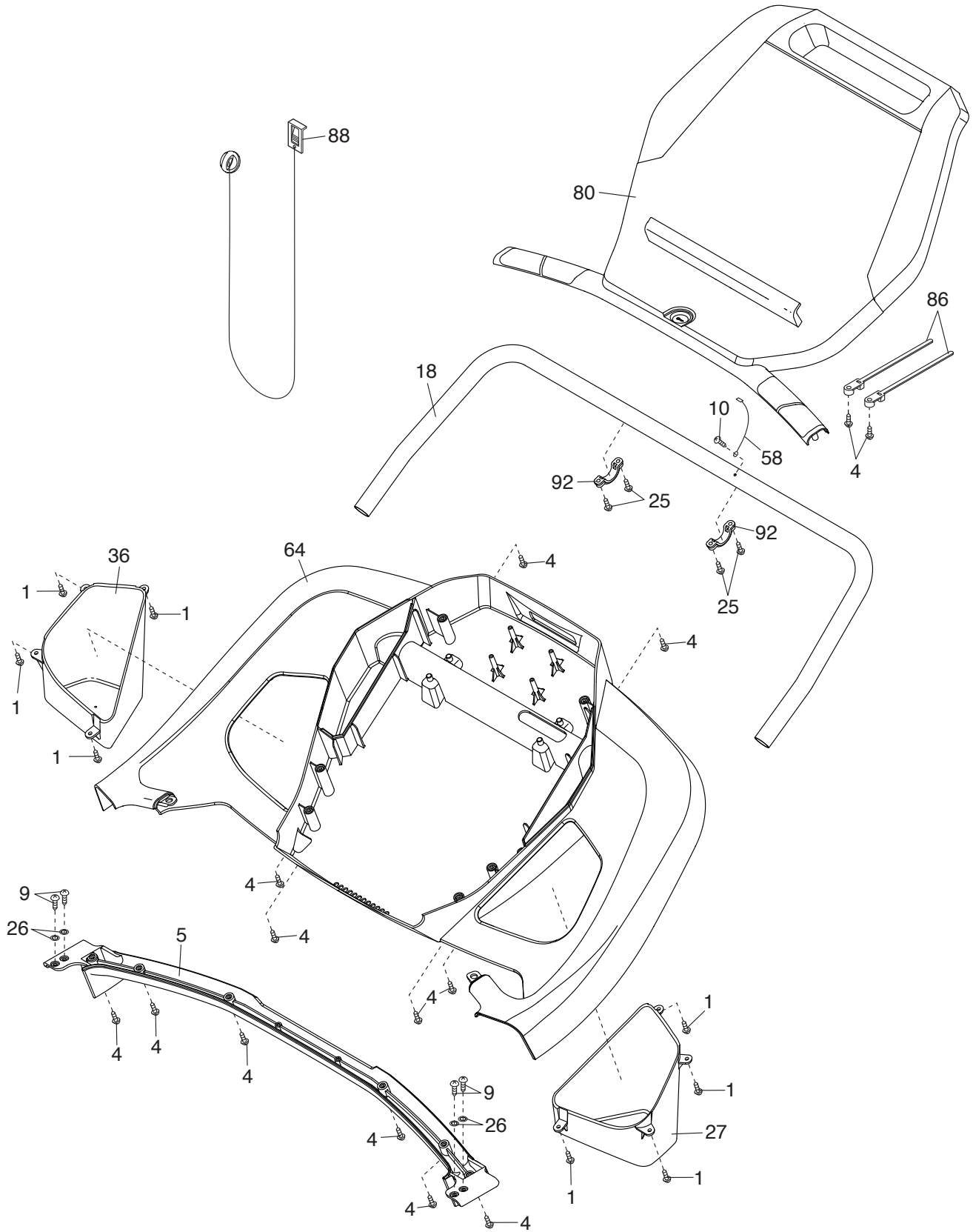

ORDERING REPLACEMENT PARTS

To order replacement parts, please see the front cover of this manual. To help us assist you, be prepared to provide the following information when contacting us:

- the model number and serial number of the product (see the front cover of this manual)
- the name of the product (see the front cover of this manual)
- the key number and description of the replacement part(s) (see the PART LIST and the EXPLODED DRAWING near the end of this manual)

RECYCLING INFORMATION

This electronic product must not be disposed of in municipal waste. To preserve the environment, this product must be recycled after its useful life as required by law.

Please use recycling facilities that are authorized to collect this type of waste in your area. In doing so, you will help to conserve natural resources and improve European standards of environmental protection. If you require more information about safe and correct disposal methods, please contact your local city office or the establishment where you purchased this product.

