

PRO-FORM®

930

2.0 HORSEPOWER DC MOTOR
0-10 MPH ◀ EXTENDED STRIDE
STEP CONTROL AUTO INCLINE ◀

Model No. PF930030

Serial No. _____

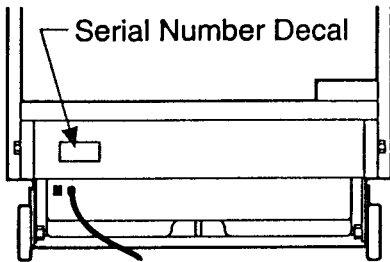

QUESTIONS?

As a manufacturer, we are committed to providing you complete customer satisfaction. If you have questions, or find there are missing or damaged parts, we will guarantee you complete satisfaction through direct assistance from our factory. TO AVOID UNNECESSARY DELAYS, PLEASE CALL DIRECT TO OUR TOLL-FREE CUSTOMER HOT LINE.

The trained technicians on our Customer Hot Line will provide immediate assistance, free of charge to you.

CUSTOMER HOT LINE:
1-800-999-3756
Mon.-Fri., 6 a.m.-6 p.m. MST

▲ CAUTION:

Read all safety precautions and instructions in this manual carefully before using this equipment. Save this manual for future reference.

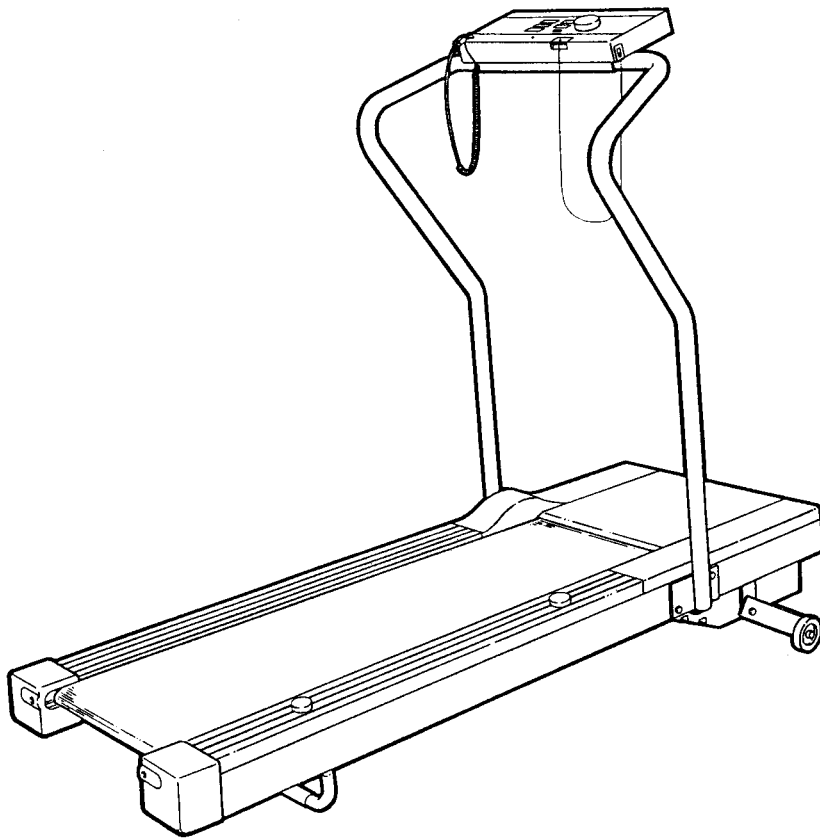

OWNER'S MANUAL

LIMITED WARRANTY

Proform Fitness Products, Inc. ("PROFORM"), warrants this product to be free from defects in workmanship and material, under normal use and service conditions, for a period of ninety (90) days from the date of purchase. This warranty extends only to the original purchaser. PROFORM's obligation under this warranty is limited to replacing or repairing, at PROFORM's option, the product at one of its authorized service centers. All products for which warranty claim is made must be received by PROFORM at one of its authorized service centers with all freight and other transportation charges prepaid, accompanied by sufficient proof of purchase. All returns must be pre-authorized by PROFORM. This warranty does not extend to any product or damage to a product caused by or attributable to freight damage, abuse, misuse, improper or abnormal usage or repairs not provided by a PROFORM authorized service center or for products used for commercial or rental purposes. No other warranty beyond that specifically set forth above is authorized by PROFORM.

PROFORM IS NOT RESPONSIBLE OR LIABLE FOR INDIRECT, SPECIAL OR CONSEQUENTIAL DAMAGES ARISING OUT OF OR IN CONNECTION WITH THE USE OR PERFORMANCE OF THE PRODUCT OR OTHER DAMAGES WITH RESPECT TO ANY ECONOMIC LOSS, LOSS OF PROPERTY, LOSS OF REVENUES OR PROFITS, LOSS OF ENJOYMENT OR USE, COSTS OF REMOVAL, INSTALLATION OR OTHER CONSEQUENTIAL DAMAGES OF WHATSOEVER NATURE. SOME STATES DO NOT ALLOW THE EXCLUSION OR LIMITATION OF INCIDENTAL OR CONSEQUENTIAL DAMAGES. ACCORDINGLY, THE ABOVE LIMITATION MAY NOT APPLY TO YOU.

THE WARRANTY EXTENDED HEREUNDER IS IN LIEU OF ANY AND ALL OTHER WARRANTIES AND ANY IMPLIED WARRANTIES OF MERCHANTABILITY OR FITNESS FOR A PARTICULAR PURPOSE IS LIMITED IN ITS SCOPE AND DURATION TO THE TERMS SET FORTH HEREIN. SOME STATES DO NOT ALLOW LIMITATIONS ON HOW LONG AN IMPLIED WARRANTY LASTS. ACCORDINGLY, THE ABOVE LIMITATION MAY NOT APPLY TO YOU.

This warranty gives you specific legal rights. You may also have other rights which vary from state to state.

PROFORM FITNESS PRODUCTS, INC., 1500 S. 1000 W., LOGAN UT 84321-9813

PRO·FORM®

930

2.0 HORSEPOWER DC MOTOR
0-10 MPH ◀ EXTENDED STRIDE
STEP CONTROL AUTO INCLINE ◀

TABLE OF CONTENTS

IMPORTANT SAFETY PRECAUTIONS	4
BEFORE YOU BEGIN	5
ASSEMBLY	6
OPERATION AND ADJUSTMENT	7
TROUBLE-SHOOTING AND STORAGE	10
CONDITIONING GUIDELINES	12
PART LIST	14
EXPLODED DRAWING	15
ORDERING REPLACEMENT PARTS	Back Cover

⚠ WARNING: Before beginning this or any exercise program, consult your physician. This is especially important for persons over the age of 35 or persons with pre-existing health problems. Read all instructions before using. PROFORM assumes no responsibility for personal injury or property damage sustained by or through the use of this product.

IMPORTANT SAFETY PRECAUTIONS

▲ WARNING: To reduce the risk of burns, fire, electric shock or injury to persons, read the following important safety precautions and information before operating the treadmill.

1. Position the treadmill on a level surface, with at least 8 feet of clearance behind the treadmill. Do not place the treadmill near water, outdoors or on any surface that blocks an air opening. Do not operate where aerosol products are used or where oxygen is being administered.
2. When connecting the power cord (see OPERATION AND ADJUSTMENT in this manual), plug the power cord directly into a grounded circuit capable of carrying 12 or more amps. No other appliance should be on the same circuit. Keep the power cord away from heated surfaces. If an extension cord is needed, use only a 14-gauge general-purpose cord of five feet or less in length with a three-wire conductor.
3. Never move the walking belt while the power is turned off. Do not operate the treadmill if the power cord or plug is damaged, or if the treadmill is not working properly. (See BEFORE YOU BEGIN in this manual if the treadmill is not working properly.)
4. Wear appropriate exercise clothing when using the treadmill; do not wear loose clothing that could become caught in the treadmill. *Always wear athletic shoes; never use the treadmill with bare feet, wearing only stockings or in sandals.* Athletic support clothes are recommended for both men and women.
5. The pulse earclip is not a medical device. Various factors, including the user's movement while exercising, may affect the accuracy of heart rate readings. The earclip is intended only as an exercise aid in determining heart rate trends in general.
6. Never start the treadmill while you are standing on the walking belt. Always hold the handrail when exercising on the treadmill.
7. Never allow more than one person on the treadmill at a time. The treadmill should not be used by persons weighing more than 250 pounds.
8. Keep small children away from the treadmill at all times. Never leave the treadmill unattended while it is running. Always turn the power off when the treadmill is not in use.
9. Never drop or insert any object into any opening.
10. To reduce the possibility of overheating, do not operate the treadmill continuously for longer than 1 hour.
11. The treadmill is capable of high speeds. Adjust the speed slowly to avoid sudden jumps in speed.
12. Use the treadmill only as described in this manual.
13. Always unplug the power cord before performing the maintenance and adjustment procedures described in this manual. Never remove the safety cover unless instructed to do so by an authorized service representative. Servicing other than the procedures in this manual should be performed by an authorized service representative only.

SAVE THESE INSTRUCTIONS

BEFORE YOU BEGIN

Thank you for selecting the PROFORM® 930 treadmill. The PROFORM 930 treadmill blends advanced technology with innovative design to let you enjoy an excellent form of cardiovascular exercise in the convenience and privacy of your home.

For your safety and benefit, read this manual carefully before using the treadmill. If you have additional questions, please call our Customer Service Department toll-free at **1-800-999-3756**, Monday through Friday, 6 a.m. until 6 p.m. Mountain Time (excluding holidays). To help us assist you, please note the product model number and serial number before calling. The model number of the treadmill is PF930030. The serial number can be found on a decal attached to the treadmill (see the front cover of this manual for the location).

Before reading further, please review the drawing below and familiarize yourself with the parts that are labeled.

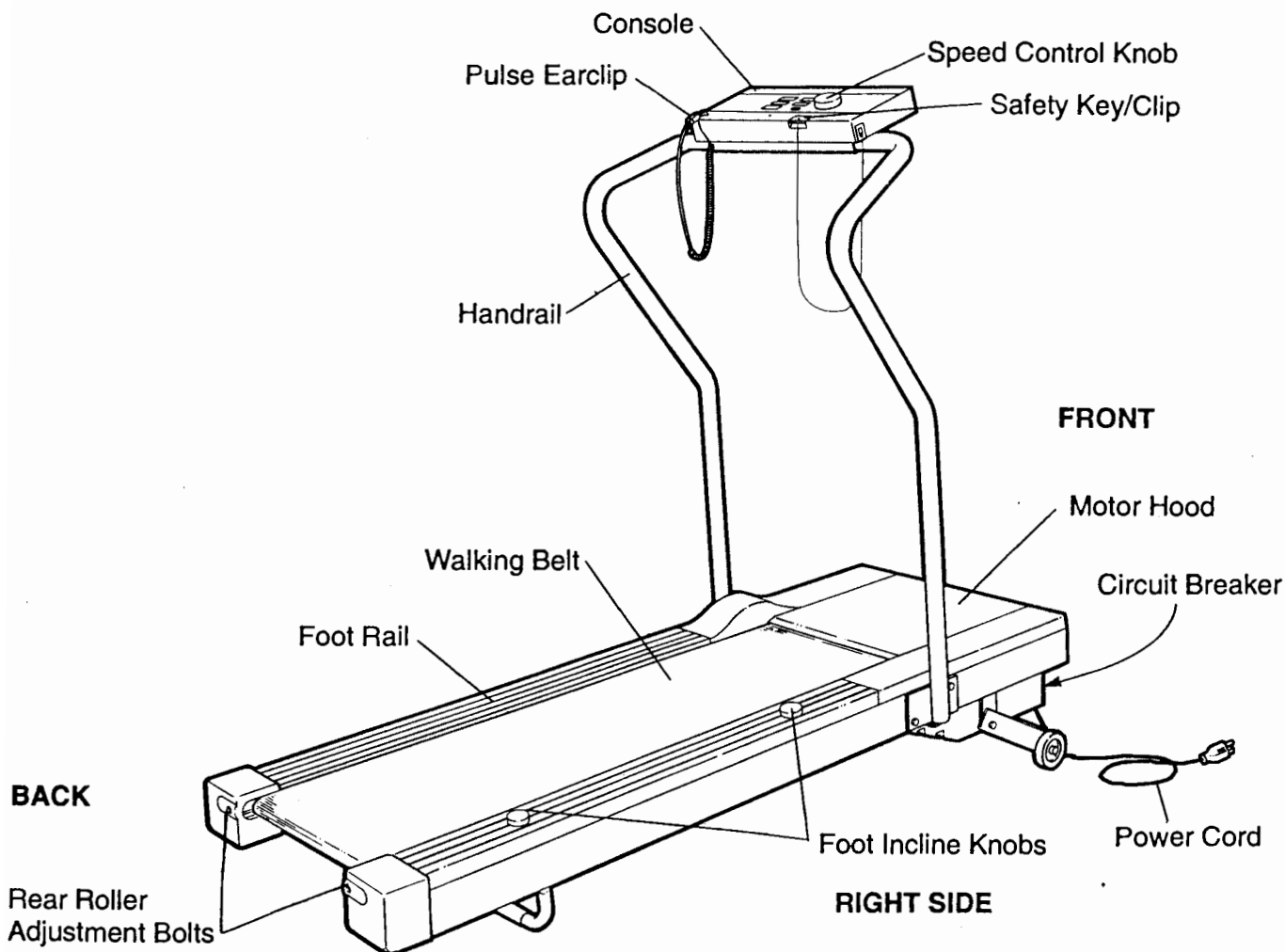

ASSEMBLY

The treadmill is delivered in the compact stowaway position. Set the treadmill in a cleared area and remove all packing materials. Do not dispose of the packing materials until assembly is completed.

TOOLS REQUIRED FOR ASSEMBLY: An 8" adjustable wrench  **(not included).**

1. To convert the treadmill to the operating position, first raise the Right Handrail (21) and the Left Handrail (not shown) to a vertical position. Align the hole in the lower end of the Right Handrail with the hole in the side of the Frame (53). Insert a Handrail Bolt (30), with a Handrail Washer (3), into the Right Handrail and tighten the Bolt into the Frame. Tighten the Handrail Bolt that is already in the Right Handrail and the Frame. **Be careful not to pinch the wires in the Right Handrail.** Attach the Left Handrail in the same manner.

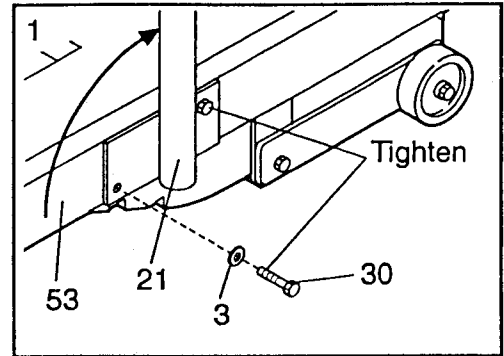

2. Remove the paper backing from the Wrench Clip (63). Press the Wrench Clip onto the Right Endcap (59) in the indicated location. Press the Allen Wrench (61) into the Wrench Clip.

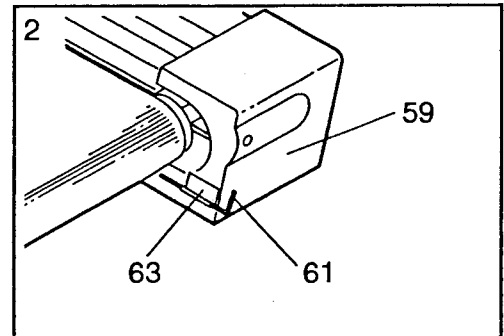

3. Slide the metal Clothes Clip onto the Pulse Earclip (6) in the indicated location. The use of the Pulse Earclip is explained in the MOTIVATIONAL FITNESS MONITOR section on page 9.

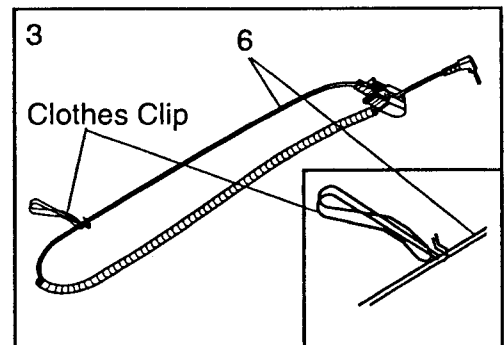

Make sure that all parts are tightened before using the treadmill.

OPERATION AND ADJUSTMENT

PLUGGING IN THE POWER CORD

This product must be grounded. If it should malfunction or break down, grounding provides a path of least resistance for electric current to reduce the risk of electric shock. This product is equipped with a cord having an equipment-grounding conductor and a grounding plug. **Plug the power cord into an appropriate outlet that is properly installed and grounded in accordance with all local codes and ordinances.**

⚠ DANGER: Improper connection of the equipment-grounding conductor can result in a risk of electric shock. Check with a qualified electrician or serviceman if you are in doubt as to whether the product is properly grounded. Do not modify the plug provided with the product—if it will not fit the outlet, have a proper outlet installed by a qualified electrician.

This product is for use on a nominal 120-volt circuit, and has a grounding plug that looks like the plug illustrated in Drawing 1. A temporary adapter that looks like the adapter illustrated in Drawing 2 may be used to connect this plug to a 2-pole receptacle as shown in Drawing 2 if a properly grounded outlet is not available. The temporary adapter should be used only until a properly grounded outlet (Drawing 1) can be installed by a qualified electrician. The green colored rigid ear, lug, or the like extending from the adapter **must be** connected to a permanent ground such as a properly grounded outlet box cover. Whenever the adapter is used it **must be** held in place by a metal screw. **Some 2-pole receptacle outlet box covers are not grounded. Contact a qualified electrician to determine if the outlet box cover is grounded before using an adapter.**

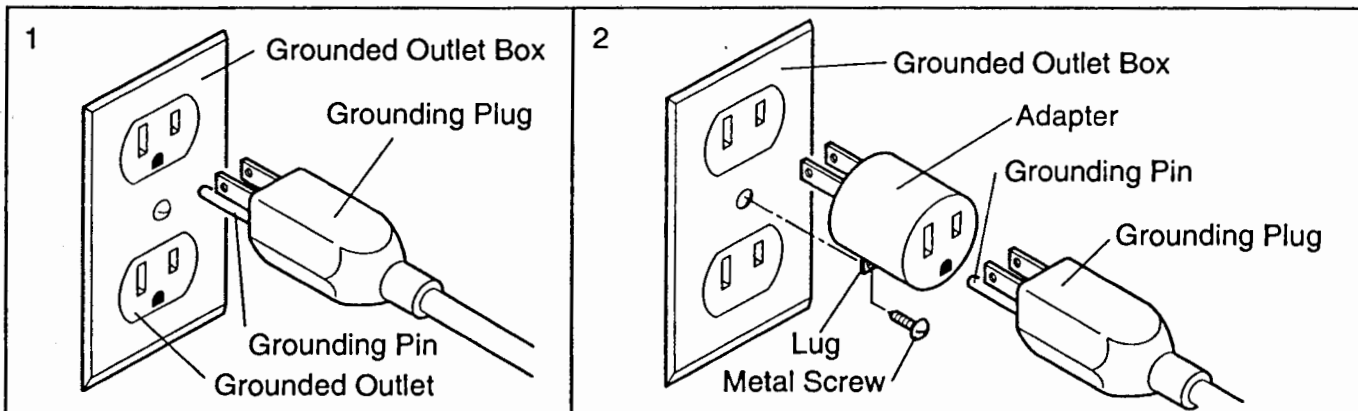

MAINTENANCE-FREE WALKING PLATFORM

This treadmill features a walking platform coated with a special hydrocarbon slip agent. **Do not apply silicone spray or any other substance to the walking platform or the walking belt.** Such substances will deteriorate the surface of the walking platform and cause excessive wear. The first time you use the treadmill, walk on the entire surface of the walking belt for 10 minutes to break in the walking platform. During this initial break-in period, it is normal for the walking belt to slow.

CHANGING THE INCLINE

To vary the intensity of your exercise, the incline of the treadmill can be changed using the foot incline knobs on the right foot rail. To increase the incline, **stand towards the back of the treadmill.** Using your right foot, press down on the back foot incline knob until the desired incline is reached. To decrease the incline, **stand towards the front of the treadmill** and press down on the front foot incline knob.

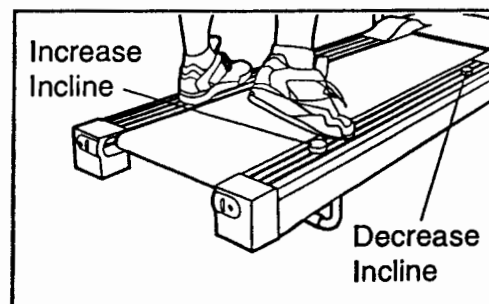
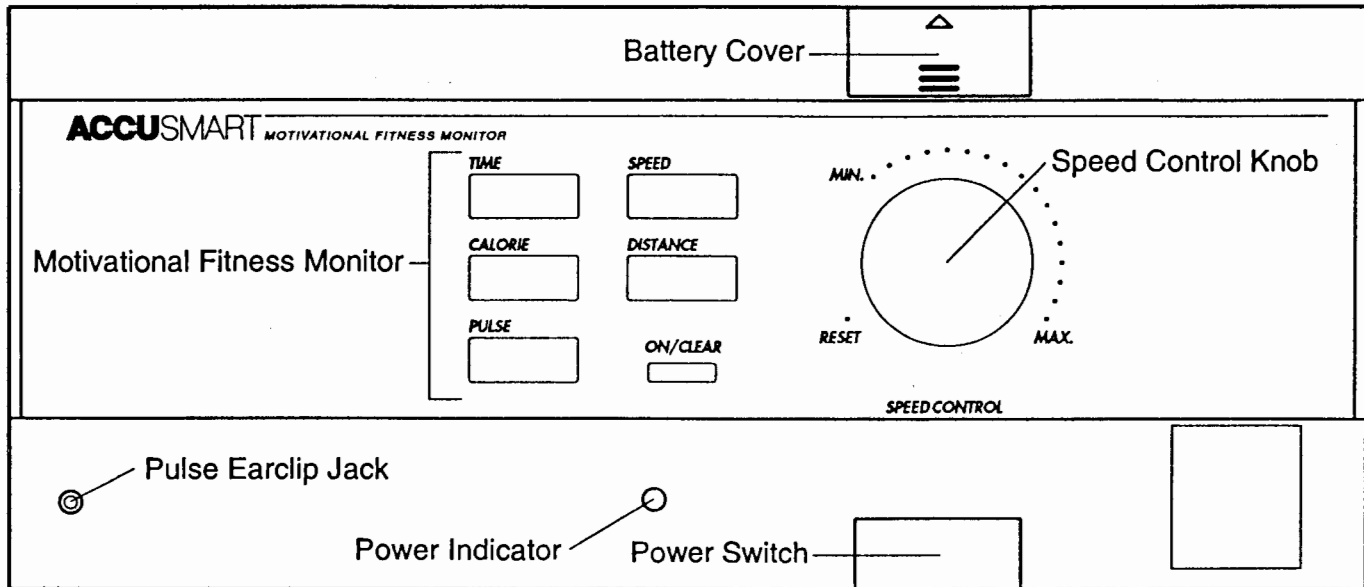
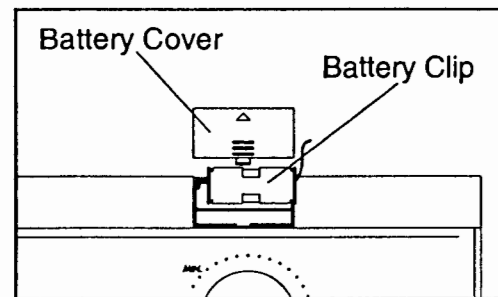

DIAGRAM OF THE CONSOLE



INSTALLING BATTERIES

The motivational fitness monitor requires **two "AA" batteries** (not included); alkaline batteries are recommended. Slide the battery cover open. Grasp the red cord and remove the battery clip from the console. Find the markings inside the battery clip showing which direction the batteries should be turned. Press the batteries into the battery clip. Replace the battery clip in the console and close the battery cover.



TURNING THE POWER ON

Step onto the foot rails of the treadmill. Locate the clip attached by a cord to the safety key, and slide the clip onto the waistband of your clothing.

⚠ CAUTION: Do not stand on the walking belt while turning the power on. Always wear the clip while operating the treadmill; if you fall, the safety key will be pulled from the power switch, instantly turning the power off.

Insert the safety key into the power switch. The power indicator will light. The five displays of the motivational fitness monitor will not appear until the ON/CLEAR button is pressed, or the walking belt begins to move (see CONTROLLING THE SPEED). Note: If batteries were just installed, the five displays will already appear.

CONTROLLING THE SPEED

To start the walking belt, first turn the speed control knob to "reset." Then, turn the knob slowly clockwise until the walking belt begins to move at slow speed.

⚠ CAUTION: After the knob is turned, there will be a pause before the walking belt begins to move. Adjust the speed slowly until you are familiar with the operation of the treadmill.

Carefully step onto the walking belt and begin exercising. Change the speed of the walking belt as desired by turning the speed control knob. To stop the walking belt, turn the knob to "reset."

MOTIVATIONAL FITNESS MONITOR

The five displays of the motivational fitness monitor provide continuous exercise feedback. The displays can be reset by pressing the ON/CLEAR button. The five displays are described below:

TIME—This display shows the elapsed time. Note: When the walking belt is stopped, the TIME display will go into a pause mode after a few seconds.

CALORIE—This display shows the total number of nutritional Calories that you have burned.

PULSE—This display shows your heart rate. Plug the pulse earclip into the jack on the console, and attach the earclip to your left ear lobe. Slide the metal clothes clip on the earclip wire onto your collar. After a few seconds, your heart rate will be displayed. If your heart rate is not displayed after a few seconds, rub your ear lobe and reposition the earclip. It may be helpful to stand still while measuring your heart rate.

SPEED—This display shows the current speed of the walking belt.

DISTANCE—This display shows the total distance that you have walked or run.

Note: If the walking belt is stopped and remains stationary for about four minutes, the five displays of the motivational fitness monitor will be reset and will darken, although the power will remain on. The five displays will appear again when the ON/CLEAR button is pressed, or the walking belt is restarted.

TURNING OFF THE POWER

To turn off the power, remove the safety key from the console. The power indicator will darken. Store the safety key in a secure location.

TROUBLE-SHOOTING AND STORAGE

Most treadmill problems can be solved by following the simple steps below. Find the symptom that applies to your treadmill and follow the steps listed. If further assistance is needed, please call our Customer Service Department toll-free at 1-800-999-3756, Monday through Friday, 6 a.m. until 6 p.m. Mountain Time (excluding holidays).

1. SYMPTOM: THE POWER DOES NOT TURN ON

- a. Make sure that the power cord is plugged into a properly grounded outlet. (See OPERATION AND ADJUSTMENT in this manual.) If an extension cord is needed, use only a 14-gauge general-purpose cord of five feet or less in length.
- b. After the power cord has been plugged in, make sure that the safety key is fully inserted into the console. Various indicators on the console should light. (See OPERATION AND ADJUSTMENT in this manual.)
- c. Check the circuit breaker located on the treadmill frame near the power cord. If the switch protrudes as shown, the circuit breaker has tripped. To reset the circuit breaker, wait for five minutes and then press the switch back in.

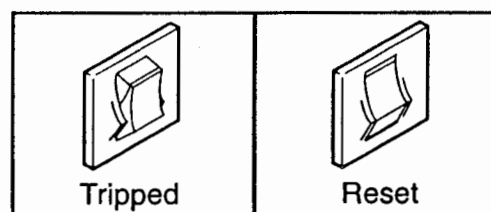

2. SYMPTOM: THE POWER TURNS OFF DURING USE

- a. Check the circuit breaker located on the treadmill frame near the power cord. If the circuit breaker has tripped, the switch will protrude. (See the drawing above.) To reset the circuit breaker, wait for five minutes and then press the switch back in.
- b. Make sure that the power cord is plugged in.
- c. Remove the safety key from the console. Reinsert the safety key fully into the console. Various indicators on the console should light.

3. SYMPTOM: THE PULSE EARCLIP DOES NOT FUNCTION PROPERLY

- a. Make sure that the pulse earclip is plugged fully into the jack on the console. Rub your left ear lobe and reposition the earclip. Attach the clothes clip to your collar.
- b. Stand still while measuring your pulse.
- c. The pulse earclip may need to be cleaned. Press the earclip open, and find the two clear circles inside the earclip. Wipe the two clear circles using a cotton swab saturated with denatured alcohol.

⚠ WARNING: The pulse earclip is not a medical device. Various factors, including the user's movement while exercising, may affect the accuracy of heart rate readings. The earclip is intended only as an exercise aid in determining heart rate trends in general.

4. SYMPTOM: THE WALKING BELT SLOWS WHEN WALKED ON

- a. The first time you use the treadmill, walk on the entire surface of the walking belt for 10 minutes to break in the walking platform. During this initial break-in period, it is normal for the walking belt to slow.
- b. If an extension cord is needed, use only a 14-gauge general-purpose cord of five feet or less in length.

- c. If the walking belt is overtightened, treadmill performance may decrease and the walking belt may be permanently damaged. Remove the safety key and **UNPLUG THE POWER CORD**. Using the allen wrench, turn both rear roller adjustment bolts counterclockwise, 1/4 of a turn. When the walking belt is properly tightened, you should be able to lift each side of the walking belt 3-4 inches off the walking platform. The center of the walking belt should just touch the walking platform. Be careful to keep the walking belt centered. Plug in the power cord, insert the safety key and run the treadmill for a few minutes. Repeat until the walking belt is properly tightened.

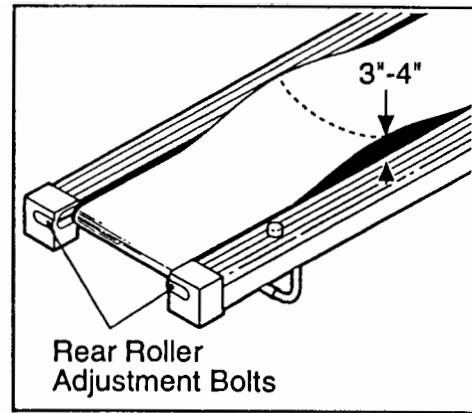

5. SYMPTOM: THE WALKING BELT IS OFF-CENTER OR SLIPS WHEN WALKED ON

- a. If the walking belt has shifted to the left, first remove the safety key and **UNPLUG THE POWER CORD**. Using the allen wrench, turn the left rear roller adjustment bolt clockwise, and the right bolt counterclockwise, 1/4 of a turn each. Be careful not to overtighten the walking belt. Plug in the power cord, insert the safety key and run the treadmill for a few minutes. Repeat until the walking belt is centered.
- b. If the walking belt has shifted to the right, first remove the safety key and **UNPLUG THE POWER CORD**. Using the allen wrench, turn the left rear roller adjustment bolt counterclockwise, and the right bolt clockwise, 1/4 of a turn each. Be careful not to overtighten the walking belt. Plug in the power cord, insert the safety key and run the treadmill for a few minutes. Repeat until the walking belt is centered.
- c. If the walking belt slips when walked on, first remove the safety key and **UNPLUG THE POWER CORD**. Using the allen wrench, turn both rear roller adjustment bolts clockwise, 1/4 of a turn. When the walking belt is correctly tightened, you should be able to lift each side of the walking belt 3-4 inches off the walking platform. The center of the walking belt should just touch the walking platform. Be careful to keep the walking belt centered. Plug in the power cord, insert the safety key and run the treadmill for a few minutes. Repeat until the walking belt is properly tightened.

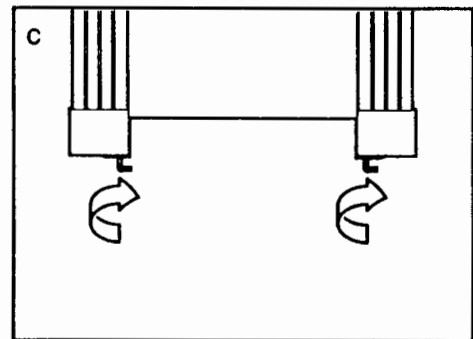
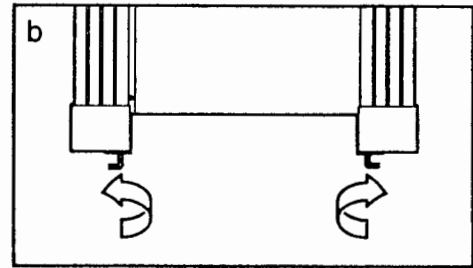
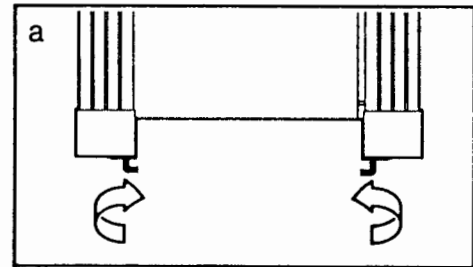

STORAGE

Unplug the power cord when the treadmill is not in use. Remove one bolt and washer from the lower end of each handrail. Loosen the other bolts in each handrail. Carefully lay the console on the treadmill. Keep the bolts and washers in a secure location. It is recommended that the treadmill be covered during extended periods of storage.

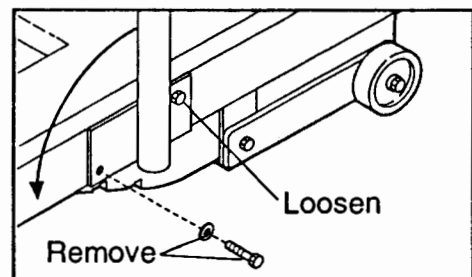

CONDITIONING GUIDELINES

The following guidelines will help you to plan your exercise program. Remember that proper nutrition and adequate rest are essential for successful results.

▲WARNING: Before beginning this or any exercise program, consult your physician. This is especially important for individuals over the age of 35 or individuals with pre-existing health problems.

EXERCISE INTENSITY

To maximize the benefits of exercising, it is important to exercise with the proper intensity. The proper intensity level can be found by using your heart rate as a guide. For effective aerobic exercise, your heart rate should be maintained at a level between 70% and 85% of your maximum heart rate as you exercise. This is known as your training zone. You can find your training zone in the table below.

AGE	UNCONDITIONED TRAINING ZONE (BEATS/MIN)	CONDITIONED TRAINING ZONE (BEATS/MIN)	AGE	UNCONDITIONED TRAINING ZONE (BEATS/MIN)	CONDITIONED TRAINING ZONE (BEATS/MIN)
20	138-167	133-162	55	127-155	122-149
25	136-166	132-160	60	126-153	121-147
30	135-164	130-158	65	125-151	119-145
35	134-162	129-156	70	123-150	118-144
40	132-161	127-155	75	122-147	117-142
45	131-159	125-153	80	120-146	115-140
50	129-156	124-150	85	118-144	114-139

During the first few months of your exercise program, keep your heart rate near the low end of your training zone as you exercise. After a few months of regular exercise, your heart rate can be increased gradually until it is near the middle of your training zone as you exercise. You can measure your heart rate using the pulse mode of the console. Exercise for at least four minutes, and then measure your heart rate immediately. If your heart rate is too high, decrease the intensity of your exercise. If your heart rate is too low, increase the intensity of your exercise.

▲WARNING: The pulse earclip is not a medical device. Various factors, including your movement during exercise, may affect the accuracy of heart rate readings. The earclip is intended only as an exercise aid in determining heart rate trends in general.

WORKOUT GUIDELINES

Each workout should consist of three basic parts: a warm-up, 20 to 30 minutes of training zone exercise, and a cool-down. Warming up prepares the body for exercise by increasing circulation, delivering more oxygen to the muscles and raising the body temperature. Begin each workout with 5 to 10 minutes of stretching and light exercise to warm up. Then, increase the intensity of your exercise to raise your heart rate to your training zone for 20 to 30 minutes. Breathe regularly and deeply as you exercise—never hold your breath. Finish each workout with 5 to 10 minutes of stretching to cool down. This will increase the flexibility of your muscles as well as help to decrease soreness and other post-exercise problems.

To maintain or improve your condition, complete three workouts each week, with at least one day of rest between workouts. After a few months of regular exercise, you may complete up to five workouts each week, if desired. The key to success is CONSISTENCY.

SUGGESTED STRETCHES

The following stretches can provide a good warm-up or cool-down. Correct form for each stretch is shown in the drawings below. Move slowly as you stretch—never bounce.

TOE TOUCH STRETCH

Stand with your knees bent slightly and slowly bend forward from your hips. Allow your back and shoulders to relax as you reach down toward your toes as far as possible. Hold for 15 counts, then relax. Repeat 3 times.

Stretches: Hamstrings, back of knees and back.

HAMSTRING STRETCH

Sit with one leg extended. Bring the sole of the opposite foot toward you and rest it against the inner thigh of your extended leg. Reach toward your toes as far as possible. Hold for 15 counts, then relax. Repeat 3 times for both legs.

Stretches: Hamstrings, lower back and groin.

CALF/ACHILLES STRETCH

With one leg in front of the other, reach forward and place your hands against a wall. Keep your back leg straight and your back foot flat on the floor. Bend your front leg, lean forward and move your hips toward the wall. Hold for 15 counts, then relax. Repeat 3 times for both legs. To cause further stretching of the achilles tendons, bend your back leg as well.

Stretches: Calves, achilles tendons and ankles.

QUADRICEPS STRETCH

With one hand against a wall for balance, reach back and grasp one foot with your other hand. Bring your heel as close to your buttocks as possible. Hold for 15 counts, then relax. Repeat 3 times for both legs.

Stretches: Quadriceps and hip muscles.

INNER THIGH STRETCH

Sit with the soles of your feet together and your knees outward. Pull your feet toward your groin area as far as possible. Hold for 15 counts, then relax. Repeat 3 times.

Stretches: Quadriceps and hip muscles.

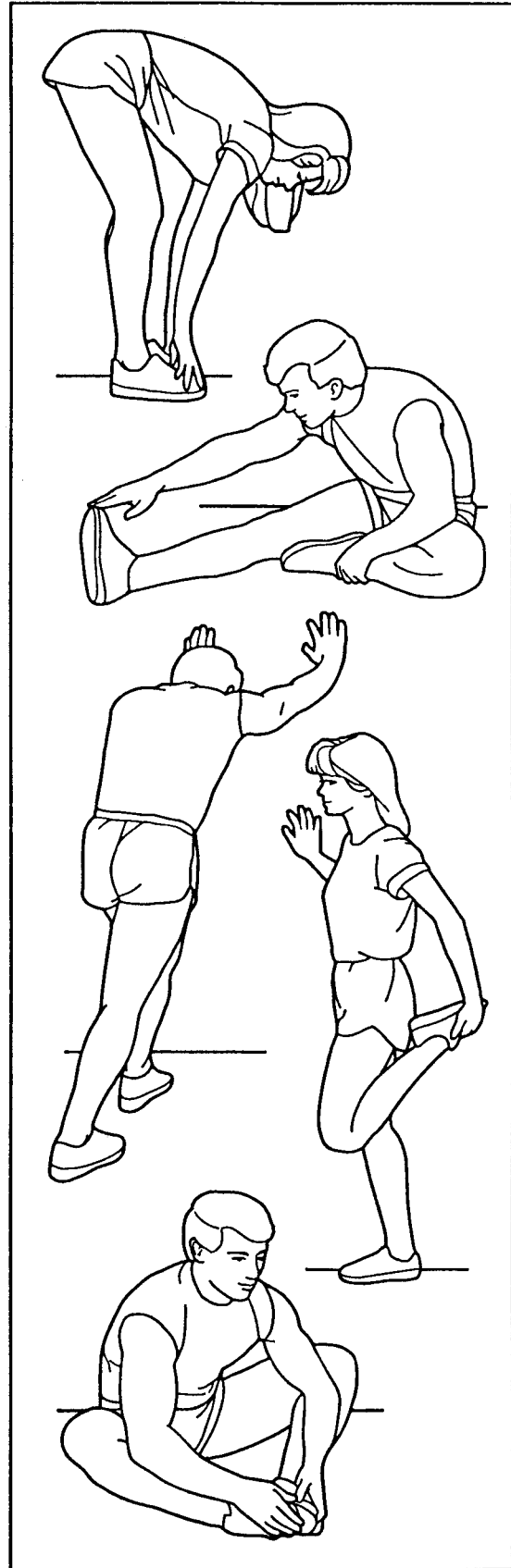

PART LIST—Model No. PF930030

Rev. 9/93

Key No.	Qty.	Description	Key No.	Qty.	Description
1	1	Left Handrail	41	1	Front Roller/Pulley
2	4	Handrail Cage Nut	42	1	Walking Platform
3	6	Handrail Washer	43	1	Walking Belt
4	4	Console Bolt/Wheel Bolt	44	1	Left Foot Rail
5	1	Safety Key/Clip	45	2	Foot Incline Knob
6	1	Pulse Earclip/Clothes Clip	46	2	Incline Lever
7	2	Shock Spacer	47	2	Incline Knob Bracket
8	1	Console	48	1	Short Incline Cable
9	19	Screw	49	2	Motor Bolt
10	1	Console Plate	50	1	Motor
11	1	Speed Control Knob	51	1	Pulley/Flywheel/Fan
12	1	Shock Release	52	2	Motor Nut
13	1	E-Clip	53	1	Frame
14	1	Shock Bracket	54	1	Rear Leg Cover
15	1	Shock Spacer	55	1	Long Incline Cable
16	1	Incline Shock	56	3	Cable Tie
17	1	Cotter Pin	57	1	Right Foot Rail
18	1	Shock Pin	58	2	Motor Swivel Bolt
19	1	Controller	59	1	Right Endcap
20	1	Choke	60	2	Rear Roller Adjustment Bolt
21	1	Right Handrail	61	1	Allen Wrench
22	1	Tension Nut	62	1	Rear Roller
23	2	Tension Washer	63	1	Wrench Clip
24	1	Tension Spring	64	1	Left Endcap
25	2	Hood Anchor	65	2	Tee Nut
26	2	Anchor Screw	66	6	Platform Screw
27	1	Grommet	67	4	Hood Screw
28	1	Power Cord	68	1	Motor Hood w/Decal
29	1	Circuit Breaker	69	1	Reed Switch/Sensor Wire
30	4	Handrail Bolt	70	1	Reed Switch Clip
31	10	Belly Pan Pin	71	1	Belt
32	1	Front Roller Adjustment Bolt	72	4	Wire Clip
33	3	Roller Adjustment Washer	73	2	Isolator
34	4	Locknut	74	1	J-Bolt
35	2	Front Wheel	75	1	Ground Wire
36	2	Leg Bolt	76	1	Motor Swivel
37	1	Incline Leg	77	2	Rear Roller Spacer
38	2	Belt Guide	78	2	Console Cage Nut
39	2	Incline Knob Sleeve	#	1	Owner's Manual
40	1	Belly Pan			

Note: "*" indicates a non-illustrated part. Specifications are subject to change without notice. See the back cover for information about ordering replacement parts.

EXPLODED DRAWING—Model No. PF930030

Rev. 9/93

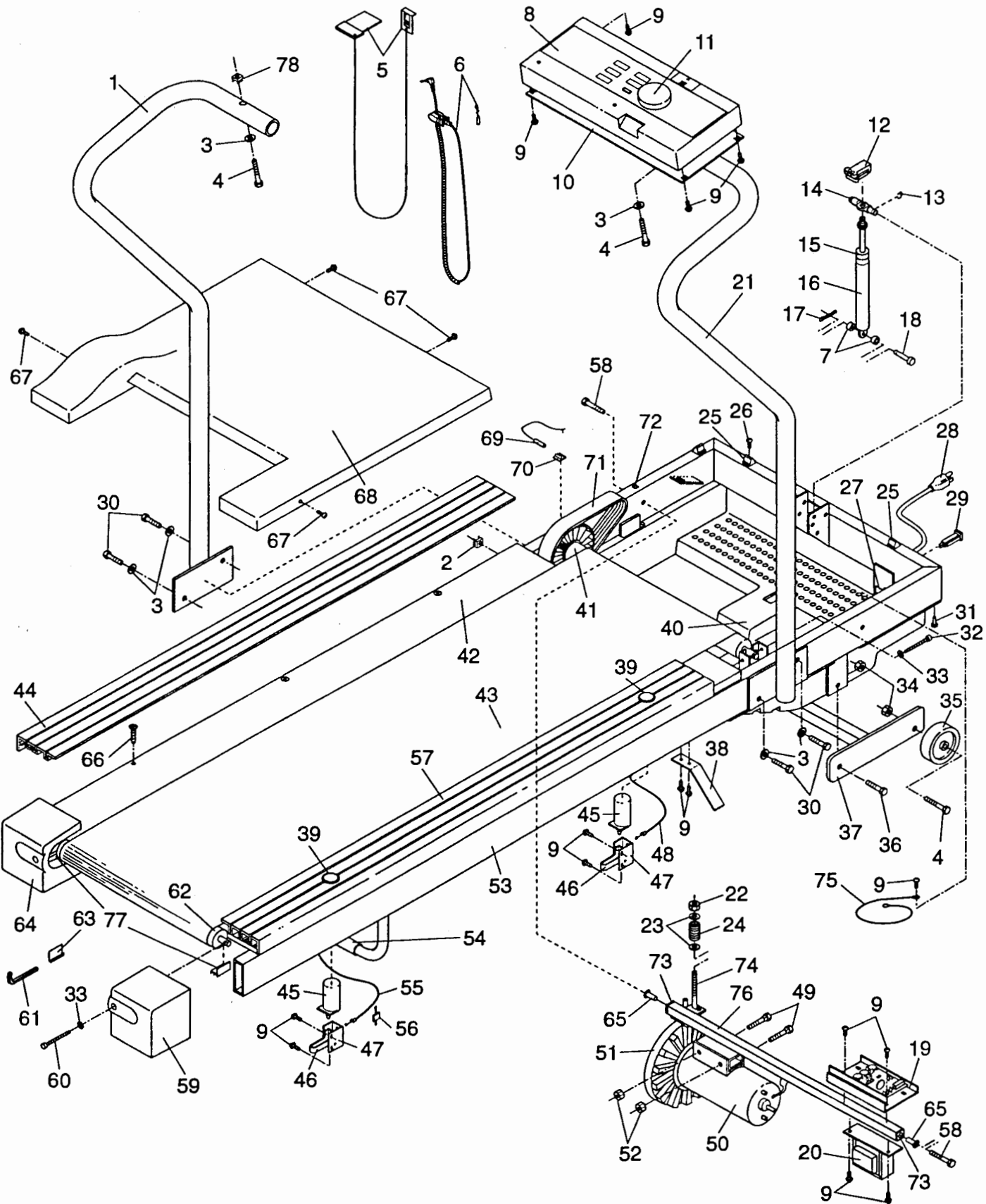

ORDERING REPLACEMENT PARTS

To order replacement parts, call our Customer Service Department toll-free at **1-800-999-3756**, Monday through Friday, 6 a.m. until 6 p.m. Mountain Time (excluding holidays). When ordering parts, please be prepared to give the following information:

1. The **MODEL NUMBER** of the product (PF930030).
2. The **NAME** of the product (PROFORM® 930 treadmill).
3. The **SERIAL NUMBER** of the product (see the front cover of this manual).
4. The **KEY NUMBER** of the part(s) from page 14 of this manual.
5. The **DESCRIPTION** of the part(s) from page 14 of this manual.

If possible, place the treadmill near your telephone for easy reference when calling.