

PRO-FORM[®]

785 F

www.proform.com

Model No. PFEL57908.1

Serial No. _____

Write the serial number in the space above for reference.

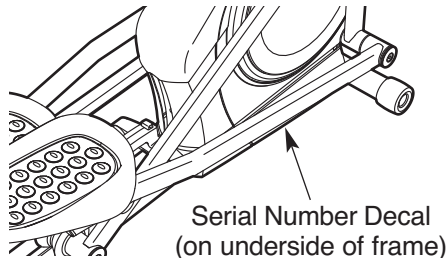

USER'S MANUAL

QUESTIONS?

As a manufacturer, we are committed to providing complete customer satisfaction. If you have questions, or if parts are damaged or missing, **DO NOT CONTACT THE STORE;** please contact Customer Care.

IMPORTANT: You must note the product model number and serial number (see the drawing above) before contacting us:

CALL TOLL-FREE:

1-888-533-1333

Mon.–Fri. 6 a.m.–6 p.m. MT

Sat. 8 a.m.–4 p.m. MT

ON THE WEB:

www.proformservice.com

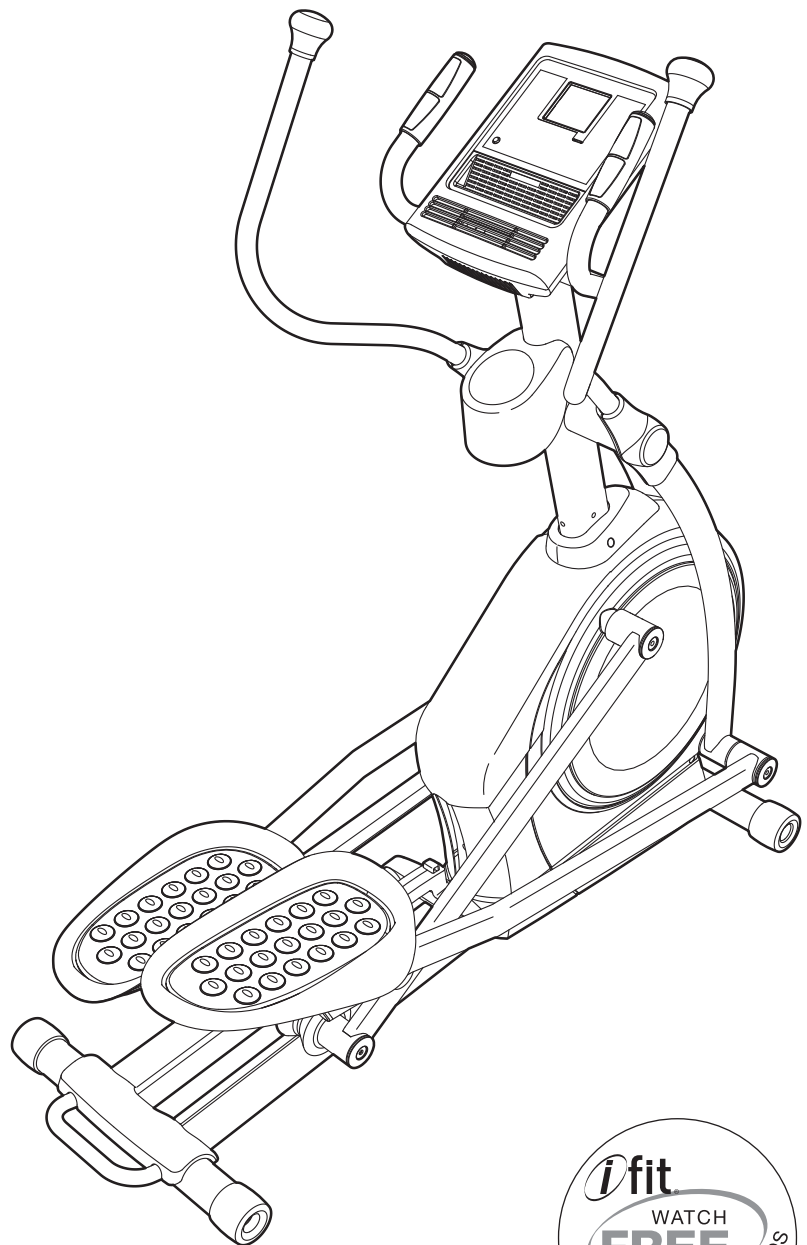

CAUTION

Read all precautions and instructions in this manual before using this equipment. Keep this manual for future reference.



TABLE OF CONTENTS

WARNING DECAL PLACEMENT2

IMPORTANT PRECAUTIONS3

BEFORE YOU BEGIN4

ASSEMBLY5

HOW TO USE THE ELLIPTICAL EXERCISER12

MAINTENANCE AND TROUBLESHOOTING20

EXERCISE GUIDELINES21

PART LIST23

EXPLODED DRAWING25

ORDERING REPLACEMENT PARTSBack Cover

LIMITED WARRANTYBack Cover

WARNING DECAL PLACEMENT

This drawing shows the location(s) of the warning decal(s). **If a decal is missing or illegible, see the front cover of this manual and request a free replacement decal. Apply the decal in the location shown.** Note: The decal(s) may not be shown at actual size.

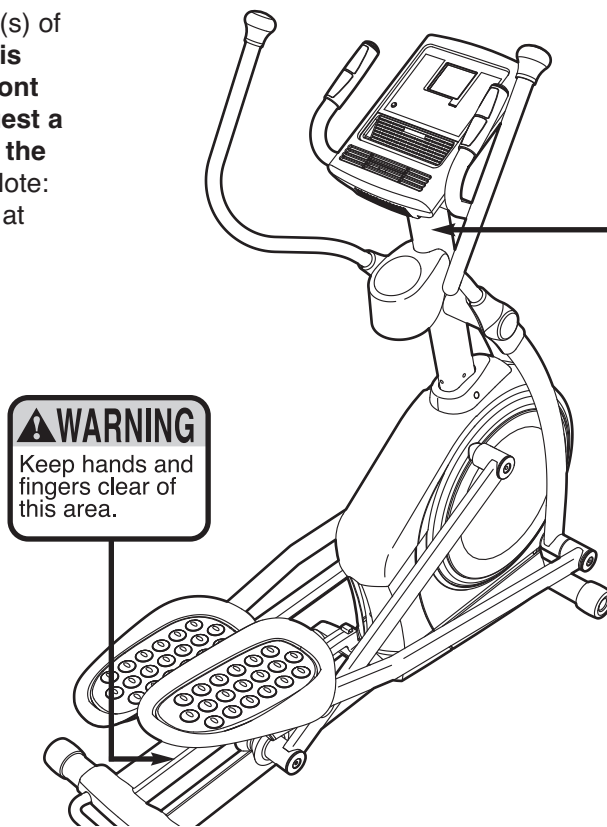

⚠ WARNING

- Misuse of this machine may result in serious injury.
- Read user's manual prior to use and follow all warnings and instructions.
- Do not allow children on or around machine.
- Pedals continue to spin when you stop pedaling.
- Spinning pedals can cause injury.
- Reduce pedal speed in a controlled manner.
- User weight must not exceed 275 pounds.
- Replace label if damaged, illegible, or removed.

IMPORTANT PRECAUTIONS

⚠️ WARNING: To reduce the risk of serious injury, read all important precautions and instructions in this manual and all warnings on your elliptical exerciser before using your elliptical exerciser. ICON assumes no responsibility for personal injury or property damage sustained by or through the use of this product.

1. Before beginning any exercise program, consult your physician. This is especially important for persons over the age of 35 or persons with pre-existing health problems.
2. It is the responsibility of the owner to ensure that all users of the elliptical exerciser are adequately informed of all precautions.
3. Your elliptical exerciser is intended for home use only. Do not use your elliptical exerciser in a commercial, rental, or institutional setting.
4. Keep your elliptical exerciser indoors, away from moisture and dust. Place your elliptical exerciser on a level surface, with a mat beneath it to protect the floor or carpet. Make sure that there is at least 3 ft. (1 m) of clearance in the front and rear of your elliptical exerciser and 2 ft. (0.6 m) on each side.
5. Inspect and properly tighten all parts regularly. Replace any worn parts immediately.
6. Keep children under age 12 and pets away from your elliptical exerciser at all times.
7. Your elliptical exerciser should not be used by persons weighing more than 275 lbs. (125 kg).
8. Wear appropriate exercise clothes when exercising; do not wear loose clothes that could become caught on your elliptical exerciser. Always wear athletic shoes for foot protection.
9. Hold the handgrip pulse sensor or the handlebars when mounting, dismounting, or using your elliptical exerciser.
10. Keep your back straight while using your elliptical exerciser; do not arch your back.
11. The pulse sensor is not a medical device. Various factors, including the user's movement, may affect the accuracy of heart rate readings. The pulse sensor is intended only as an exercise aid in determining heart rate trends in general.
12. When you stop exercising, allow the pedals to slowly come to a stop.
13. If you feel pain or dizziness while exercising, stop immediately and cool down.
14. Use your elliptical exerciser only as described in this manual.

BEFORE YOU BEGIN

Thank you for selecting the new PROFORM® 785 F elliptical exerciser. The 785 F elliptical exerciser provides a wide array of features designed to make your workouts at home more effective and enjoyable.

For your benefit, read this manual carefully before you use the elliptical exerciser. If you have questions after reading this manual, please see the front cover of this manual. To help us assist you, note the product model number and serial number before con-

tacting us. The model number and the location of the serial number decal are shown on the front cover of this manual.

To avoid a registration fee for any service needed under warranty, you must register the exercise cycle at www.proformservice.com/registration.

Before reading further, please familiarize yourself with the parts that are labeled in the drawing below.

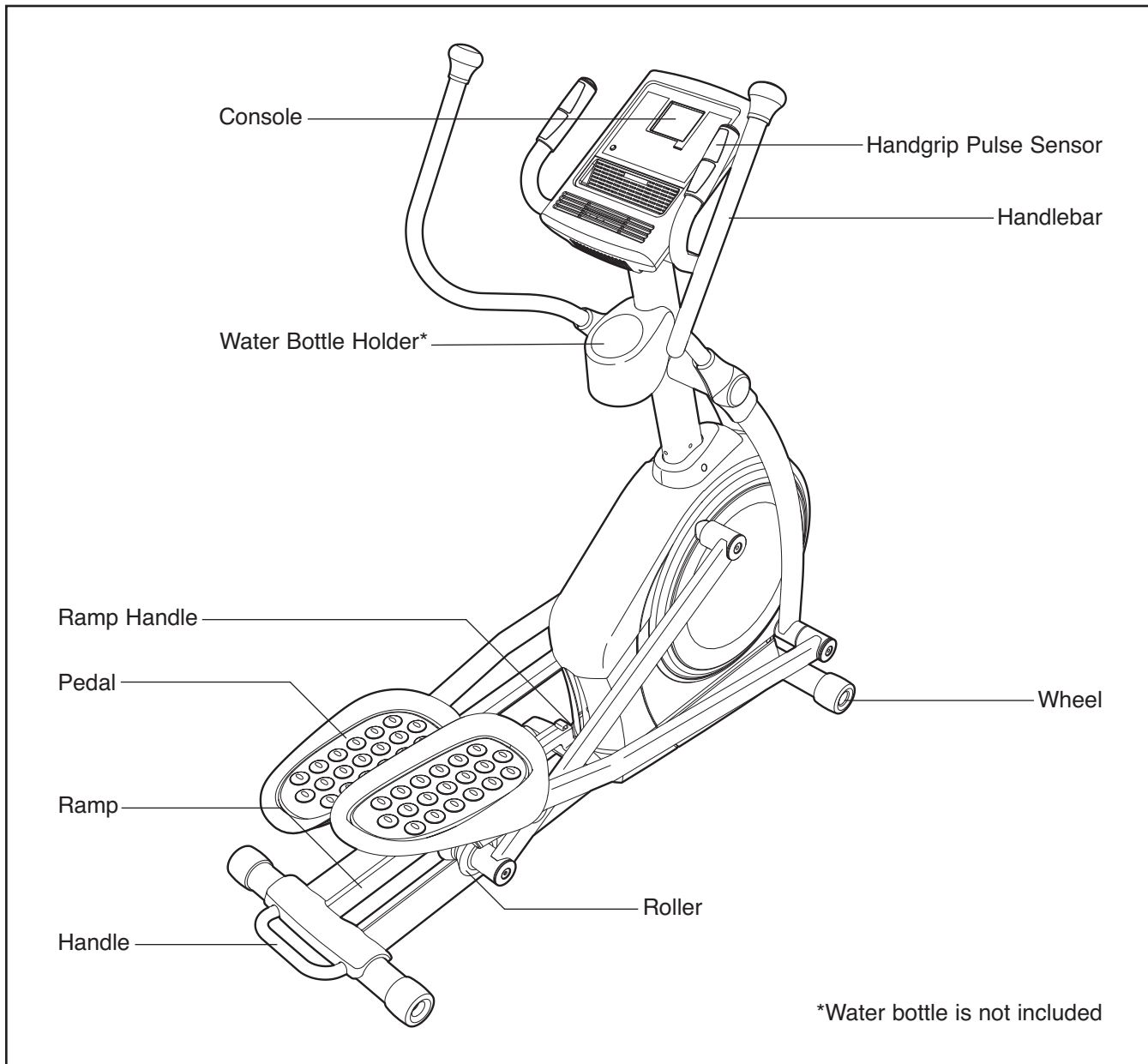

ASSEMBLY

To hire an authorized service technician to assemble the elliptical exerciser, call 1-800-445-2480.

Assembly requires two persons. Place all parts of the elliptical exerciser in a cleared area and remove the packing materials. Do not dispose of the packing materials until assembly is completed.

In addition to the included tool(s), assembly requires a Phillips screwdriver , an adjustable wrench , and a rubber mallet .

As you assemble the elliptical exerciser, use the drawings below to identify small parts. The number in parentheses below each drawing is the key number of the part, from the PART LIST near the end of this manual. The number following the parentheses is the quantity needed for assembly. **Note: Some small parts may have been preassembled. If a part is not in the hardware kit, check to see if it has been preassembled.**

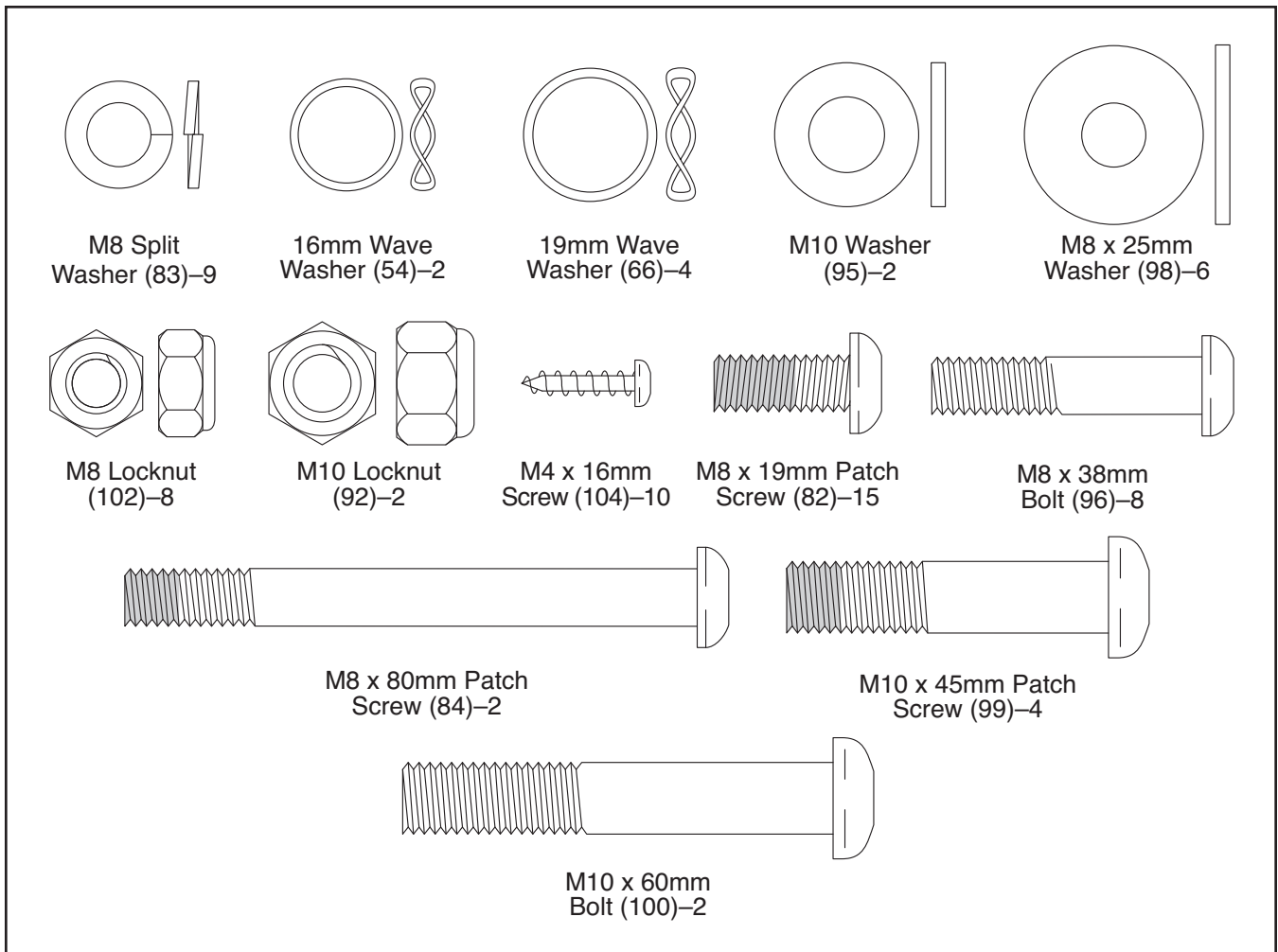

1.

To make assembly easier, read the information on page 5 before you begin.

Attach the Front Stabilizer (6) to the Frame (1) with two M8 x 80mm Patch Screws (84).

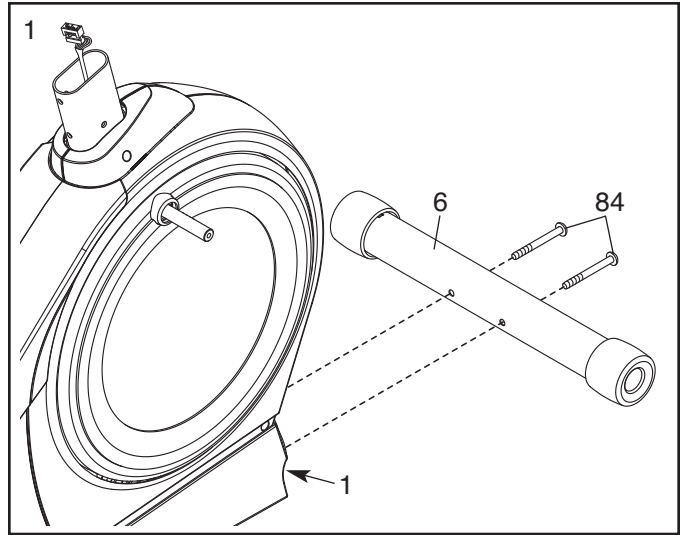

2. Orient the Ramp (3) as shown. Then, insert the Ramp into the Frame (1).

Attach the Ramp (3) with five M8 x 19mm Patch Screws (82) and five M8 Split Washers (83).

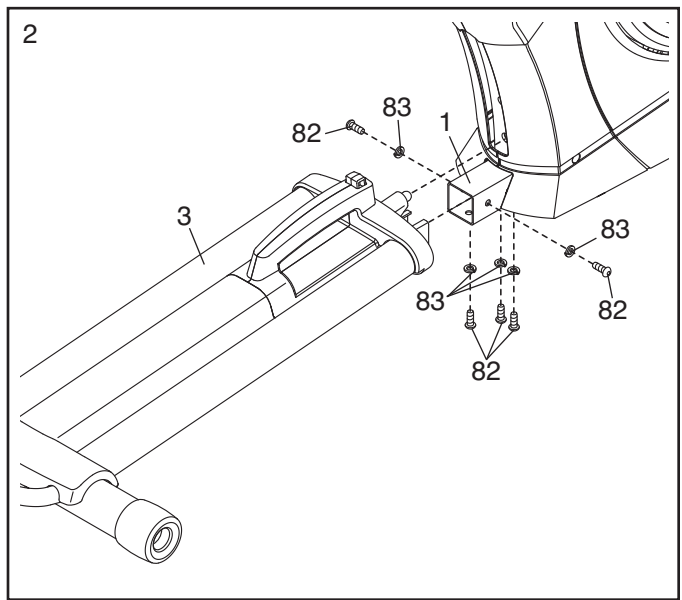

3. While a second person holds the Upright (4) near the Frame (1), connect the Upper Wire Harness (110) to the Lower Wire Harness (111).

Tip: Avoid pinching the wires. Slide the Upright (4) onto the Frame (1). Attach the Upright with four M8 x 19mm Patch Screws (82) and four M8 Split Washers (83). **Do not tighten the Patch Screws yet.**

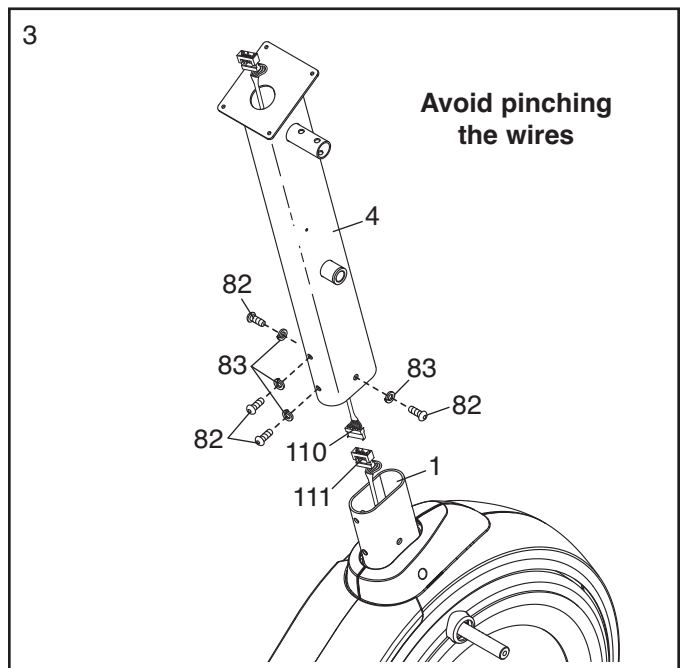

4. Apply a small amount of the included grease to the right Crank Arm (20) and to a 19mm Wave Washer (66).

Slide a Crank Arm Spacer (55) and the 19mm Wave Washer (66) onto the right Crank Arm (20).

Identify the Right Roller Arm (59), which is marked with a "Right" sticker, and orient it as shown.

Slide the Right Roller Arm (59) onto the right Crank Arm (20). Attach the Right Roller Arm with an M8 x 19mm Patch Screw (82), an Axle Cover (53), and an M8 x 25mm Washer (98); **to avoid breaking the Axle Cover, do not over-tighten the Patch Screw.**

Repeat this step for the Left Roller Arm (not shown).

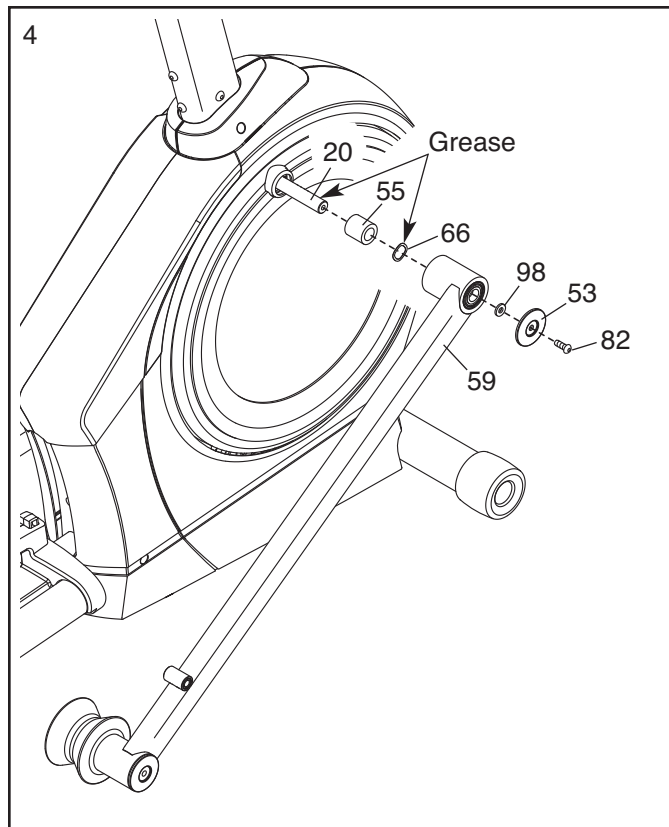

5. Identify the Right Pedal Bracket (64), which is marked with a "Right" sticker.

Apply a small amount of grease to the inside of the tube on the Right Roller Arm (59) and to the barrel of an M10 x 60mm Bolt (100).

Attach the Right Pedal Bracket (64) to the Right Roller Arm (59) with the M10 x 60mm Bolt (100), an M10 Washer (95), and an M10 Locknut (92). **Do not overtighten the Locknut; the Right Pedal Bracket must pivot freely.**

Repeat this step for the Left Pedal Bracket (48).

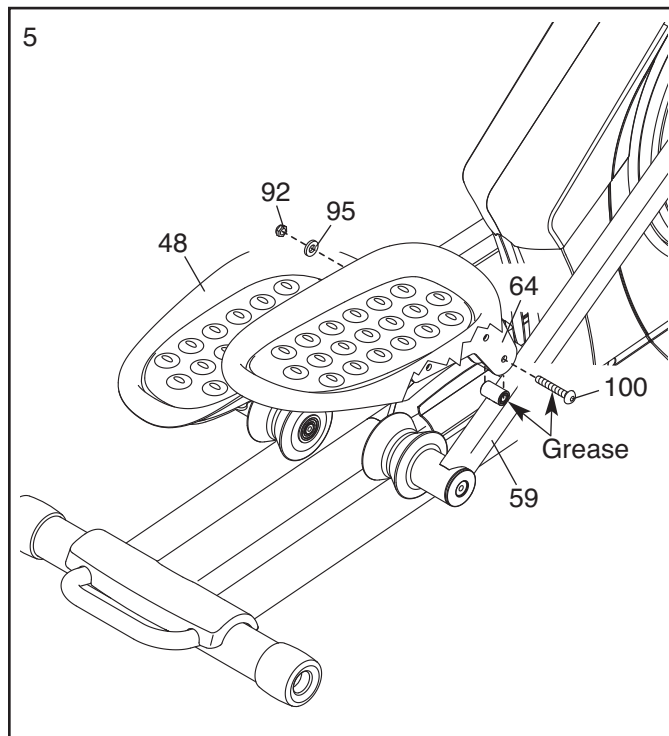

6. Identify the Right Handlebar (61) and the Right Handlebar Leg (60), which are marked with "Right" stickers, and orient them as shown. **Make sure that the hexagonal holes are in the indicated location.**

Slide the Right Handlebar (61) onto the Right Handlebar Leg (60).

Attach the Right Handlebar (61) with two M8 x 38mm Bolts (96) and two M8 Locknuts (102). **Make sure that the Locknuts are in the hexagonal holes.**

Repeat this step for the Left Handlebar (not shown) and the Left Handlebar Leg (not shown).

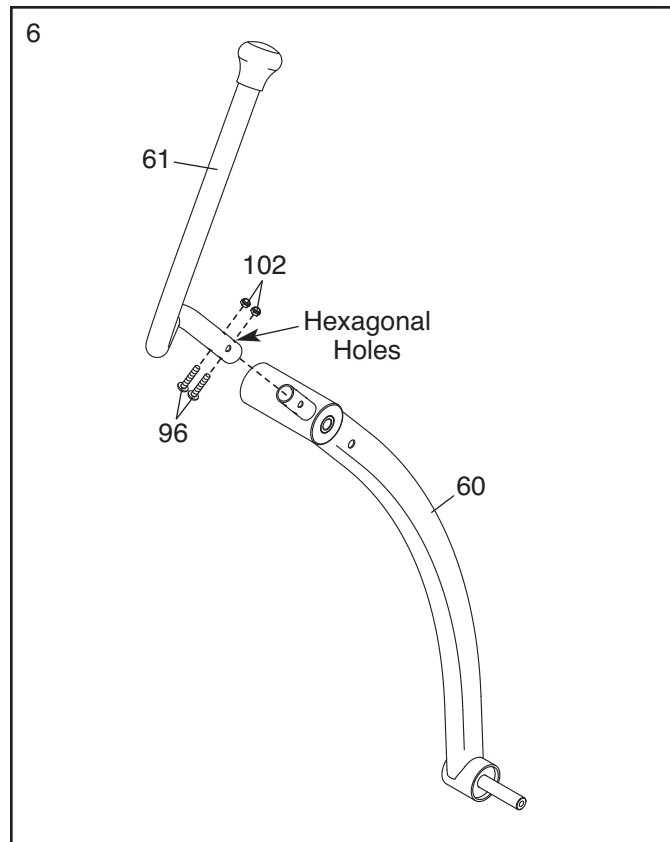

7. Apply a small amount of grease to the Pivot Axle (35) and to a 16mm Wave Washer (54).

Insert the Pivot Axle (35) through the Upright (4) and then center it.

Slide the 16mm Wave Washer (54), an Inner Handlebar Cover (68), and the Right Handlebar Leg (60) onto the right side of the Pivot Axle (35).

Repeat this step for the Left Handlebar Leg (not shown).

Tighten an M8 x 19mm Patch Screw (82) and an M8 x 25mm Washer (98) into each end of the Pivot Axle (35).

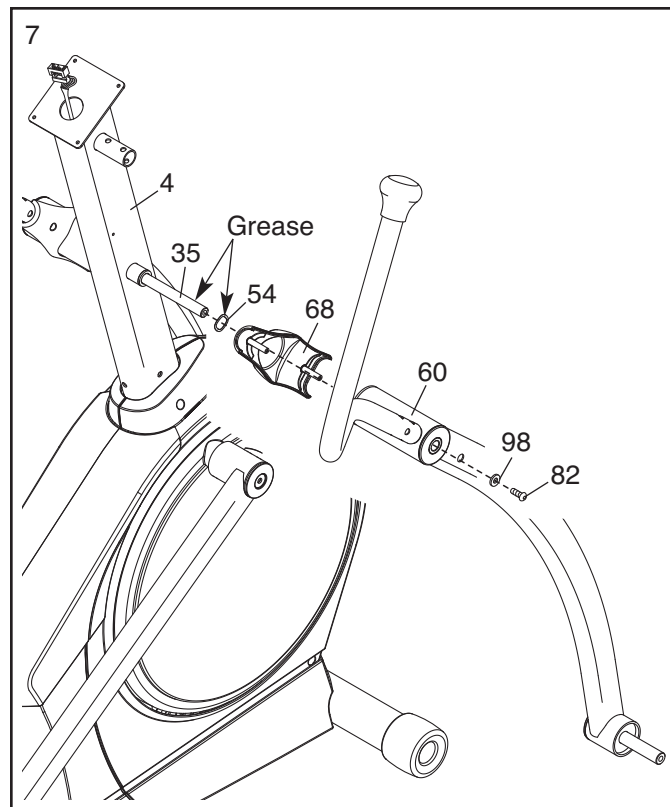

- Attach an Outer Handlebar Cover (67) and the Inner Handlebar Cover (68) around the Right Handlebar Leg (60) with two M4 x 16mm Screws (104).

Repeat this step for the other side of the elliptical exerciser.

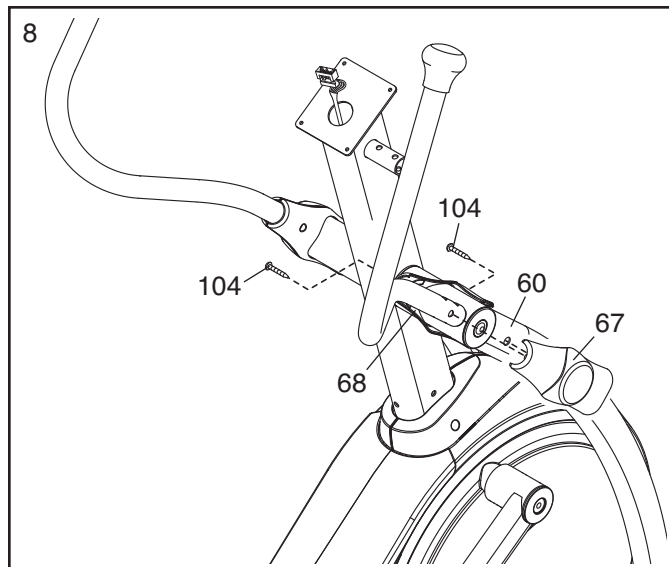

- Apply a small amount of grease to the axle on the Right Handlebar Leg (60) and to a 19mm Wave Washer (66).

Identify the Right Pedal Arm (58), which is marked with a "Right" sticker, and orient it as shown.

Slide the 19mm Wave Washer (66) and the Right Pedal Arm (58) onto the Right Handlebar Leg (60).

Attach the Right Pedal Arm (58) with an M8 x 19mm Patch Screw (82), an Axle Cover (53), and an M8 x 25mm Washer (98); **to avoid breaking the Axle Cover, do not overtighten the Patch Screw.**

Repeat this step for the Left Pedal Arm (not shown).

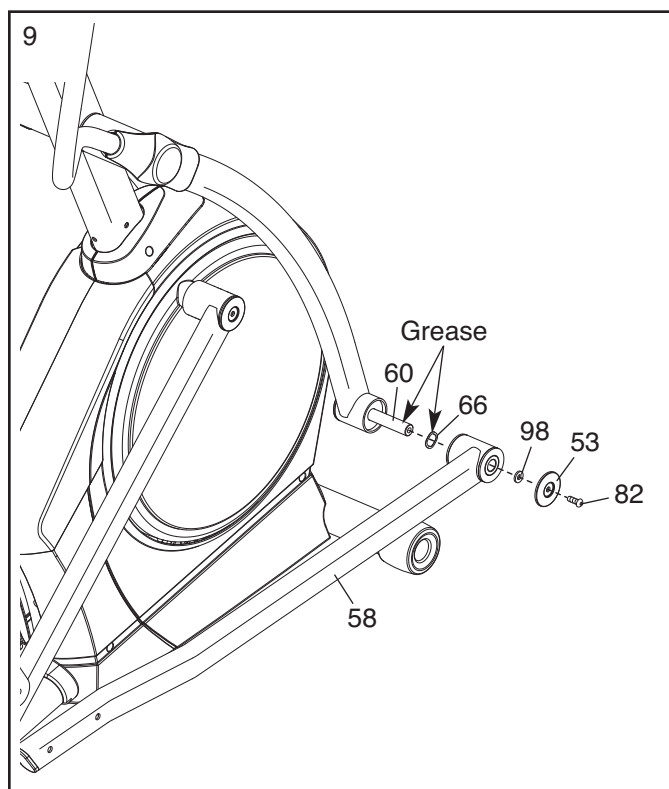

10. Attach the Right Pedal Arm (58) to the Right Pedal Bracket (64) with two M10 x 45mm Patch Screws (99).

Repeat this step for the Left Pedal Arm (44).

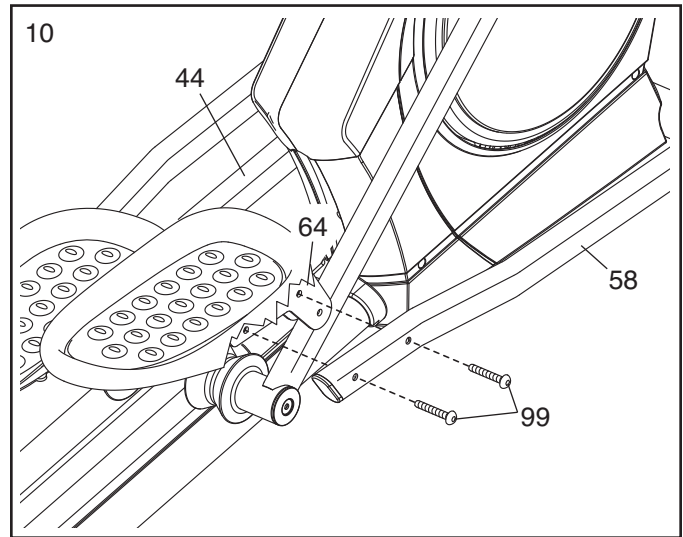

11. Identify the Right Pulse Bar (9), which is marked with a "Right" sticker.

See the inset drawing. Locate the wire tie in the Upright (4). Tie the lower end of the wire tie to the Pulse Wire (63) in the Right Pulse Bar (9). Next, pull the upper end of the wire tie upward out of the top of the Upright. Then, untie and discard the wire tie.

Slide the Right Pulse Bar (9) onto the right side of the Upright (4). **Make sure that the hexagonal holes are in the indicated location.**

Tip: Avoid pinching the wires. Attach the Right Pulse Bar (9) with two M8 x 38mm Bolts (96) and two M8 Locknuts (102). **Make sure that the Locknuts are in the hexagonal holes.**

Repeat this step for the Left Pulse Bar (8).

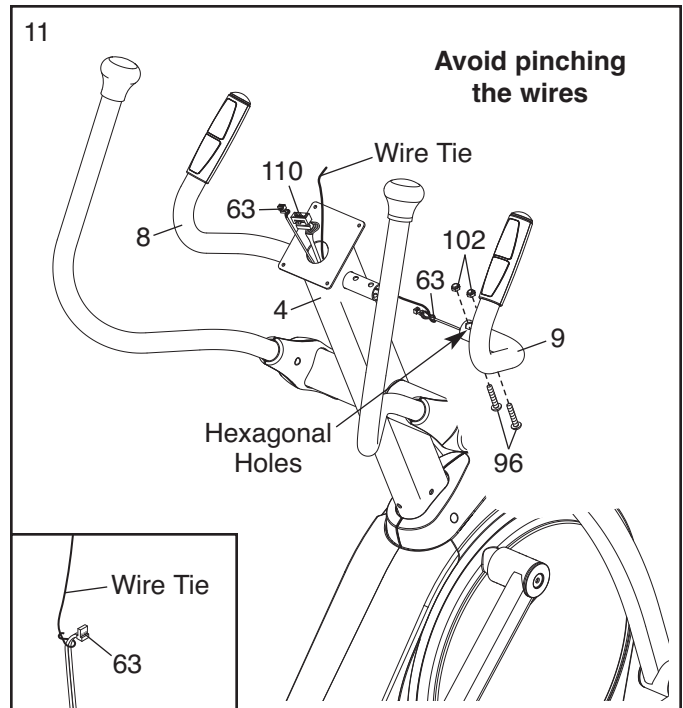

12. Attach the Water Bottle Holder (37) to the Upright (4) with two M4 x 16mm Screws (104).

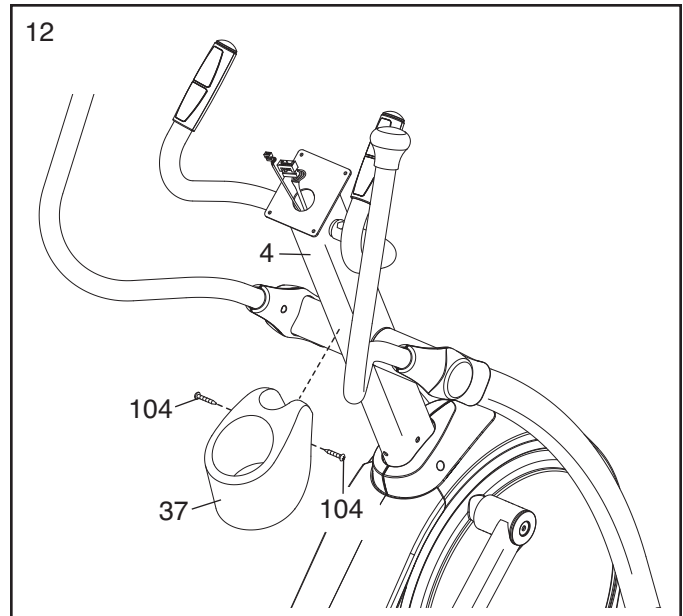

13. While a second person holds the Console (7) near the Upright (4), connect the console wire to the Upper Wire Harness (110). Then, connect the console pulse wires to the Pulse Wires (63).

Insert the excess wire downward into the Upright (4).

Tip: Avoid pinching the wires. Attach the Console (7) to the Upright (4) with four M4 x 16mm Screws (104).

See step 3. Tighten the M8 x 19mm Patch Screws (82).

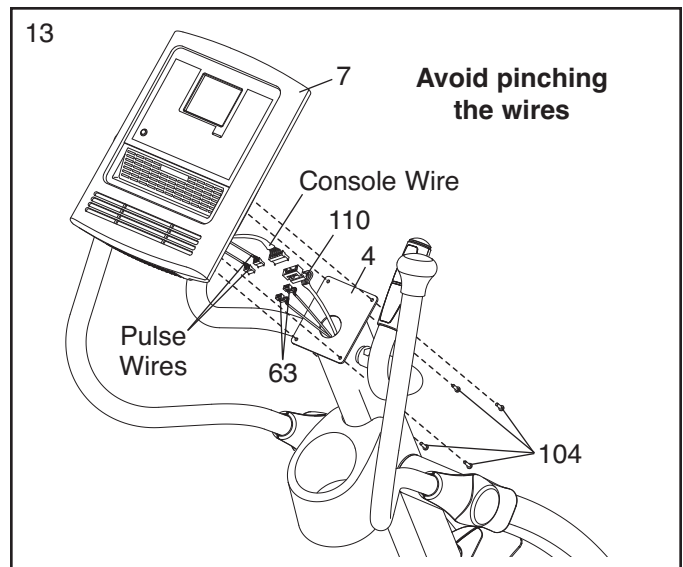

14. Plug the power adapter into the jack on the back of the console (see HOW TO PLUG IN THE POWER ADAPTER on page 12). **IMPORTANT: If the elliptical exerciser has been exposed to cold temperatures, allow it to warm to room temperature before plugging in the power adapter. If you do not do this, you may damage the console displays or other electronic components.**

Make sure that all parts are properly tightened before you use the elliptical exerciser. Note: After assembly is completed, some extra parts may be left over. Place a mat beneath the elliptical exerciser to protect the floor.

HOW TO USE THE ELLIPTICAL EXERCISER

HOW TO PLUG IN THE POWER ADAPTER

Plug one end of the included power adapter into the jack on the console. Plug the other end of the power adapter into an appropriate outlet that is properly installed in accordance with all local codes and ordinances.

Note: The console can also be operated with four 1.5V D batteries (not included); alkaline batteries are recommended. Locate the battery cover on the back of the console. Remove the battery cover, insert the batteries into the battery compartment, and then reattach the battery cover. **Make sure to orient the batteries as shown by the diagrams inside the battery compartment.**

HOW TO MOVE THE ELLIPTICAL EXERCISER

Due to the size and weight of the elliptical exerciser, moving it requires two persons. Stand in front of the elliptical exerciser, hold the upright, and place one foot against one of the front wheels. Pull on the upright and have a second person lift the handle on the ramp until the elliptical exerciser will roll on the front wheels. Carefully move the elliptical exerciser to the desired location, and then lower it to the floor.

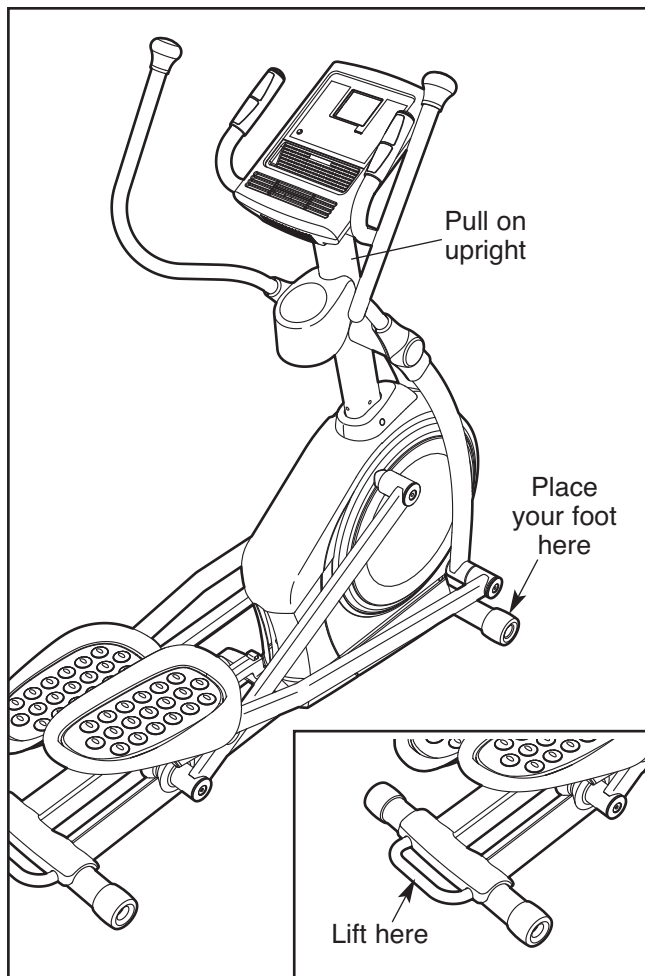

HOW TO EXERCISE ON THE ELLIPTICAL EXERCISER

To mount the elliptical exerciser, hold the handlebars and step onto the pedal that is in the lower position. Then, step onto the other pedal. Push the pedals until they begin to move with a continuous motion. **Note: The crank arms can turn in either direction. It is recommended that you turn the crank arms in the direction shown by the arrow; however, for variety, you can turn the crank arms in the opposite direction.**

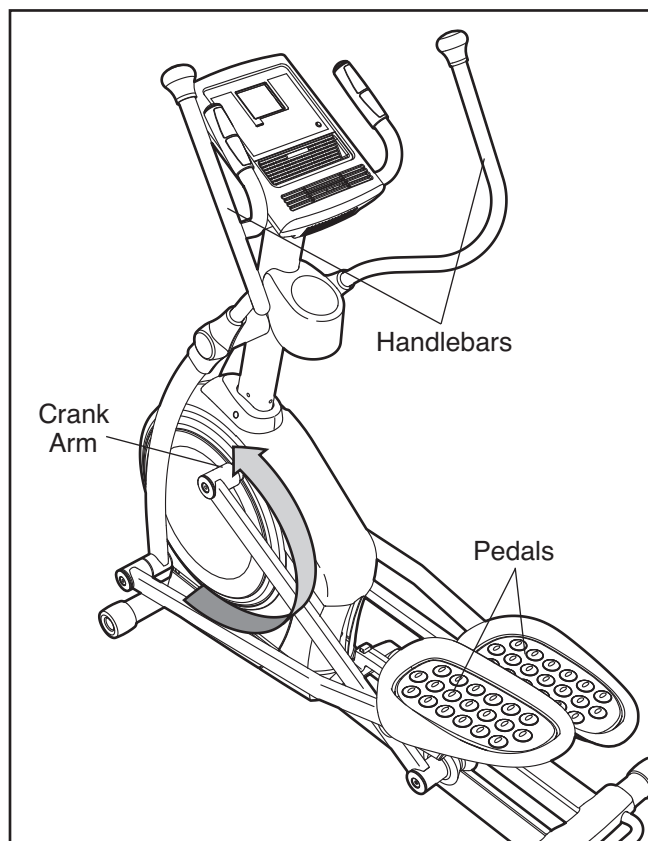

To dismount the elliptical exerciser, wait until the pedals come to a complete stop. **Note: The elliptical exerciser does not have a free wheel; the pedals will continue to move until the flywheel stops.** When the pedals are stationary, step off the higher pedal first. Then, step off the lower pedal.

HOW TO CHANGE THE INCLINE OF THE RAMP

To vary the motion of the pedals, you can change the incline of the ramp. To change the incline, press the latch button, pull the ramp handle, and raise or lower the ramp to the desired incline level. Then, release the latch button and engage the latch pin into one of the adjustment holes in the frame. The white line on the latch button must be visible or the latch pin is not fully engaged. **Make sure that the latch pin is firmly engaged in one of the adjustment holes in the frame.**

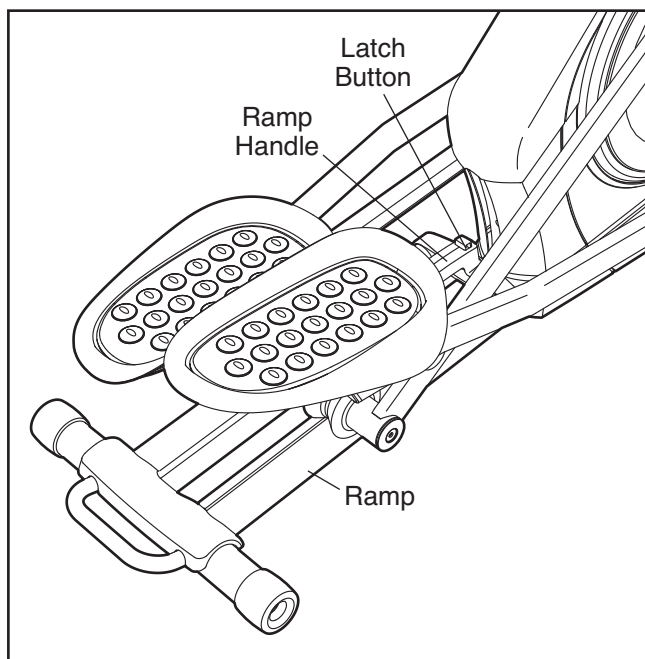

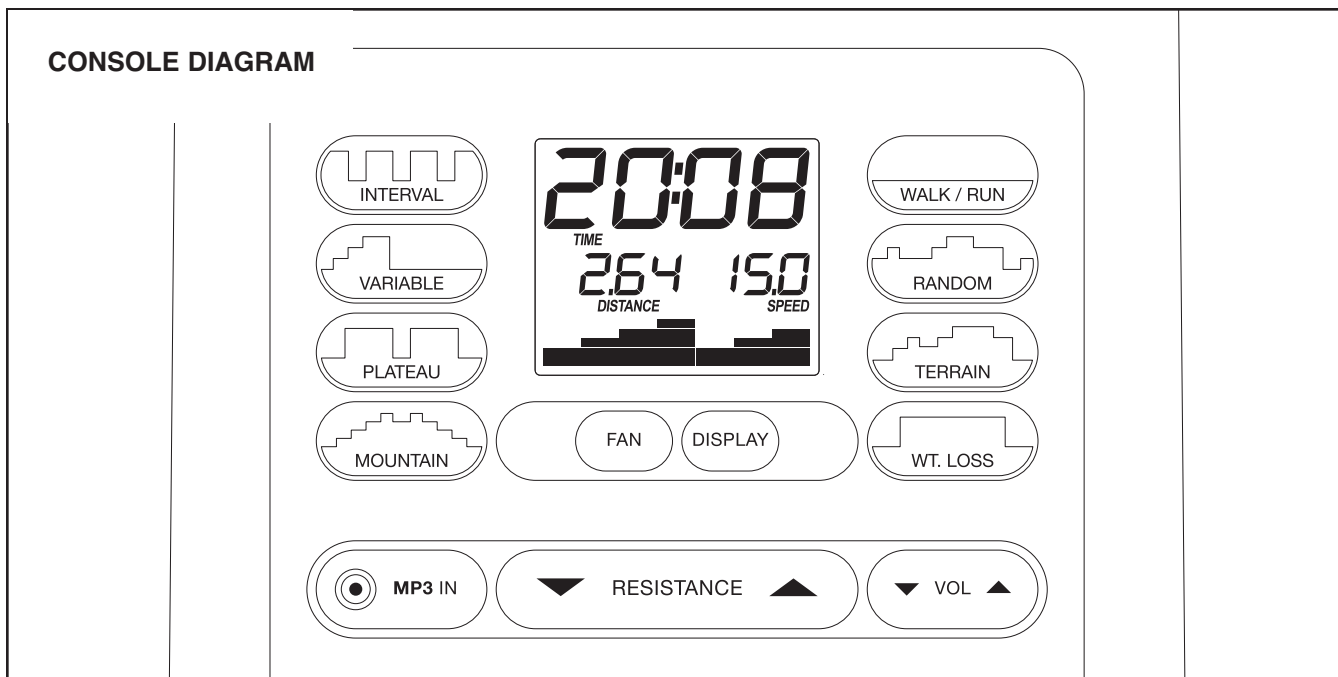

FEATURES OF THE CONSOLE

The revolutionary console offers an array of features designed to make your workouts more effective and enjoyable. When you use the manual mode of the console, you can change the resistance of the pedals with the touch of a button. While you exercise, the console will display continuous exercise feedback. You can also measure your heart rate using the handgrip pulse sensor.

In addition, the console offers twelve trainer workouts and six weight loss workouts. Each workout automatically changes the resistance of the pedals as it guides you through an effective workout.

You can even connect your MP3 player or CD player to the console's sound system and listen to your favorite music or audio books while you exercise.

To use the manual mode, see page 15. **To use a trainer workout**, see page 17. **To use a weight loss workout**, see page 18. **To randomly select a workout**, see page 18. **To use the sound system**, see page 19. **To change console settings**, see page 19.

Note: If there is a sheet of clear plastic on the face of the console, remove the plastic.

HOW TO USE THE MANUAL MODE

1. **Begin pedaling or press any button on the console to turn on the console.**

A moment after you begin pedaling or press a button, a tone will sound, and the display will light.

2. **Select the manual mode.**

Each time you turn on the console, the manual mode will be selected. If you have selected a workout, reselect the manual mode by pressing any of the workout buttons repeatedly until zeros appear in the display.

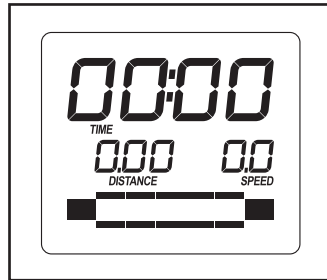

3. **Change the resistance of the pedals as desired.**

As you pedal, change the resistance of the pedals by pressing the Resistance increase and decrease buttons. Note: After you press the buttons, it will take a moment for the pedals to reach the selected resistance level.



4. **Follow your progress with the display.**

The lower left display

As you exercise, the lower left display can show the elapsed time and the distance (in miles or kilometers) that you have pedaled. Note: When a workout is selected, the display will show the time remaining in the workout instead of the elapsed time.



The lower right display—The lower right display can show your pedaling speed (in miles or kilometers per hour) and the approximate number of calories that you have burned. The display also shows your heart rate when you use the handgrip pulse sensor (see step 5 on page 16).



The upper display

The upper display can show the elapsed time, the distance that you have pedaled, your pedaling speed, and the approximate number of calories you have burned. Press the Display button repeatedly until the upper display shows the information that you are most interested in viewing. Note: While information is shown in the upper display, the same information will not be shown in the lower left or lower right display.



The lower display

The lower display will show a track representing 1/4 mile (402 meters). As you exercise, indicators will appear in succession around the track until the entire track appears. The track will then disappear and the indicators will again begin to appear in succession.

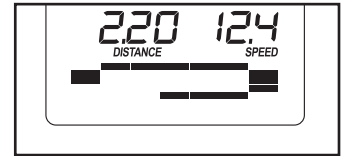

To change the volume level of the console, press the Volume increase and decrease buttons.

Note: The console can show pedaling speed and distance in either miles or kilometers. To view or change the unit of measurement, see HOW TO CHANGE CONSOLE SETTINGS on page 19.

5. Measure your heart rate if desired.

If there are sheets of clear plastic on the metal contacts on the handgrip pulse sensor, remove the plastic. To measure your heart rate, hold the handgrip pulse sensor with your palms resting against the metal contacts. **Avoid moving your hands or gripping the contacts tightly.**

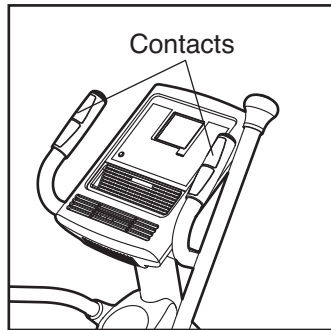

When your pulse is detected, a flashing heart symbol will appear in the display, and then your heart rate will



appear. For the most accurate heart rate reading, hold the contacts for at least 15 seconds. Note: If you continue to hold the handgrip pulse sensor, the display will show your heart rate for up to 30 seconds.

If the display does not show your heart rate, make sure that your hands are positioned as described. Be careful not to move your hands excessively or to squeeze the metal contacts tightly. For optimal performance, clean the metal contacts using a soft cloth; **never use alcohol, abrasives, or chemicals to clean the contacts.**

6. Turn on the fan if desired.

Press the Fan button repeatedly to turn on the fan or to turn off the fan. Note: If the pedals do not move for about thirty seconds, the fan will turn off automatically.

7. When you are finished exercising, the console will turn off automatically.

If the pedals do not move for several seconds, a tone will sound and the console will pause.

If the pedals do not move for several minutes and the buttons are not pressed, the console will turn off and the display will be reset.

HOW TO USE A TRAINER WORKOUT

1. Begin pedaling or press any button on the console to turn on the console.

A moment after you begin pedaling or press a button, a tone will sound, and the display will light.

2. Select a trainer workout.

To select a trainer workout, press the Interval, Variable, Plateau, Mountain, Walk/Run, or Terrain button repeatedly until the name of the desired workout appears in the display. The workout time and a profile of the resistance levels for the workout will also appear in the display.

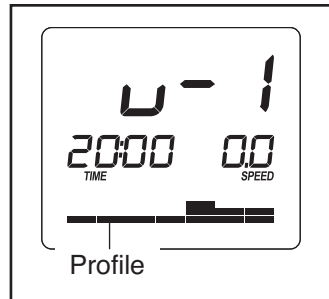

3. Begin pedaling to start the workout.

Each workout is divided into 20, 30 or 45 one-minute segments. One resistance level is programmed for each segment. Note: The same resistance level may be programmed for consecutive segments.

The resistance level for the first segment will appear in the display for a few seconds. During the workout, the workout profile will show your progress (see the drawing above). The flashing segment of the profile represents the current segment of the workout. The height of the flashing segment indicates the resistance level for the cur-

rent segment. At the end of each segment of the workout, a series of tones will sound and the next segment of the profile will begin to flash. If a different resistance level is programmed for the next segment, the resistance level will appear in the display for a few seconds to alert you. The resistance of the pedals will then change.

If the resistance level for the current segment is too high or too low, you can manually override the setting by pressing the Resistance buttons.

IMPORTANT: When the current segment of the workout ends, the pedals will automatically adjust to the resistance level programmed for the next segment.

The workout will continue in this way until the last segment ends. To stop the workout at any time, stop pedaling. A tone will sound and the time will stop counting. To restart the workout, simply resume pedaling.

4. Follow your progress with the display.

See step 4 on page 15.

5. Measure your heart rate if desired.

See step 5 on page 16.

6. Turn on the fan if desired.

See step 6 on page 16.

7. When you are finished exercising, the console will turn off automatically.

See step 7 on page 16.

HOW TO USE A WEIGHT LOSS WORKOUT

1. **Begin pedaling or press any button on the console to turn on the console.**

A moment after you begin pedaling or press a button, a tone will sound, and the display will light.

2. **Select a weight loss workout.**

To select a weight loss workout, press the Wt. Loss button until the name of the desired workout appears in the display. The workout time and a profile of the resistance levels for the workout will also appear in the display.

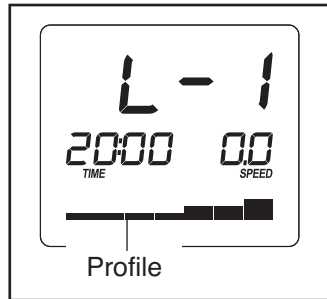

3. **Begin pedaling to start the workout.**

Each workout is divided into 30 one-minute segments. One resistance level is programmed for each segment. Note: The same resistance level may be programmed for consecutive segments.

The resistance level for the first segment will appear in the display for a few seconds. During the workout, the workout profile will show your progress (see the drawing above). The flashing segment of the profile represents the current segment of the workout. The height of the flashing segment indicates the resistance level for the current segment. At the end of each segment of the workout, a series of tones will sound and the next segment of the profile will begin to flash. If a different resistance level is programmed for the next segment, the resistance level will appear in the display for a few seconds to alert you. The resistance of the pedals will then change.

If the resistance level for the current segment is too high or too low, you can manually override the setting by pressing the Resistance buttons.

IMPORTANT: When the current segment of the workout ends, the pedals will automatically adjust to the resistance level programmed for the next segment.

The workout will continue in this way until the last segment ends. To stop the workout at any time, stop pedaling. A tone will sound and the time will stop counting. To restart the workout, simply resume pedaling.

4. **Follow your progress with the display.**

See step 4 on page 15.

5. **Measure your heart rate if desired.**

See step 5 on page 16.

6. **Turn on the fan if desired.**

See step 6 on page 16.

7. **When you are finished exercising, the console will turn off automatically.**

See step 7 on page 16

HOW TO RANDOMLY SELECT A WORKOUT

To randomly select one of the trainer or weight loss workouts for your exercise session, press the Random button once. The name of a workout, the workout time, and a profile of the resistance levels for the workout will appear in the display.

You can then start the workout if desired or you can press the Random button a second time to randomly select another trainer or weight loss workout.

You can also press the Random button a third time to return to the manual mode.

HOW TO USE THE SOUND SYSTEM

To play music or audio books through the console's sound system while you exercise, plug an audio cable (not included) into the jack on the console and into a jack on your MP3 player or CD player; **make sure that the audio cable is fully plugged in.**

Next, press the play button on your MP3 player or CD player. Adjust the volume level using the volume control on your MP3 player or CD player.

HOW TO CHANGE CONSOLE SETTINGS

The console features a user mode that allows you to select a unit of measurement and a backlight option for the console and to view console usage information.

1. Select the user mode.

To select the user mode, press and hold down the Display button for a few seconds until the user mode information appears in the display.

2. Select a backlight option if desired.

The console has three backlight options. The ON option keeps the backlight on while the console is on. The AUTO option keeps the backlight on only while you are pedaling. The OFF option turns the backlight off.

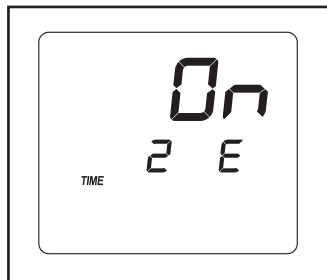

The upper display will show the currently selected backlight option. Press the Resistance increase button repeatedly to select the desired backlight option.

3. Select a unit of measurement if desired.

The console can show pedaling speed and distance in either miles or kilometers.

The lower right display will show the selected unit of measurement. An E for English miles or an M for metric kilometers will appear in the lower right display. To change the unit of measurement, press the Resistance decrease button repeatedly.

Note: When you replace the batteries, it may be necessary to reselect the unit of measurement.

4. View console usage information if desired.

The lower left display will show the total number of hours that the console has been used since the elliptical exerciser was purchased.

5. Exit the user mode.

Press the Display button to save the console settings and exit the user mode.

MAINTENANCE AND TROUBLESHOOTING

Inspect and tighten all parts of the elliptical exerciser regularly. Replace any worn parts immediately.

To clean the elliptical exerciser, use a damp cloth and a small amount of mild soap. **IMPORTANT: To avoid damage to the console, keep liquids away from the console and keep the console out of direct sunlight.**

CONSOLE TROUBLESHOOTING

If the console does not display your heart rate when you hold the handgrip pulse sensor, or if the displayed heart rate appears to be too high or too low, see step 5 on page 16.

HOW TO ADJUST THE DRIVE BELT

If the pedals slip while you are pedaling, even while the resistance is adjusted to the highest level, the drive belt may need to be adjusted. To adjust the drive belt, first use a flat screwdriver to rotate the right Disc (71) counterclockwise. Then, remove the right Disc from the right Disc Mount (72).

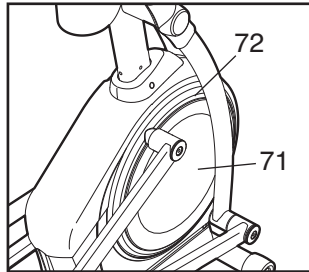

Locate and loosen the M10 x 22mm Bolt (89). Next, tighten the M8 x 38mm Hex Screw (88) until the Drive Belt (113) is tight. Then, retighten the M10 x 22mm Bolt.

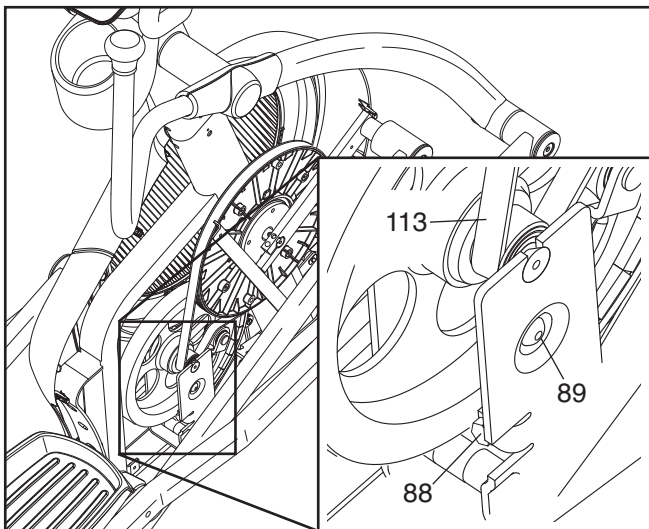

Reattach the right disc by rotating it clockwise into the right disc mount.

HOW TO ADJUST THE REED SWITCH

If the console does not display correct feedback, the reed switch should be adjusted. To adjust the reed switch, first use a flat screwdriver to rotate the left disc counterclockwise. Then, remove the left disc from the left disc mount.

Locate the Reed Switch (38). Loosen, but do not remove, the indicated M4 x 16mm Reed Switch Screw (69). Slide the Reed Switch slightly closer to or away from a Magnet (43) on the Pulley (19). Then, retighten the M4 x 16mm Screw. Turn the Pulley for a moment. Repeat until the console displays correct feedback.

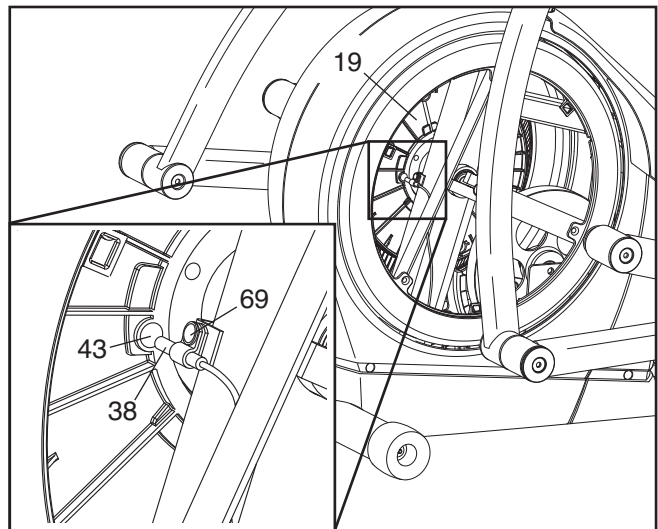

Reattach the left disc by rotating it clockwise into the left disc mount.

HOW TO GREASE THE ROLLERS

See the EXPLODED DRAWING near the end of this manual. If the Rollers (51) squeak when moving on the Ramp (3), apply a small amount of white marine grease equally to each Roller. Spread the grease evenly around the Rollers. Pedal the elliptical exerciser until a thin film of grease is distributed along the Ramp; wipe off any excess grease.

EXERCISE GUIDELINES

⚠ WARNING: Before beginning this or any exercise program, consult your physician. This is especially important for persons over the age of 35 or persons with pre-existing health problems.

The pulse sensor is not a medical device. Various factors may affect the accuracy of heart rate readings. The pulse sensor is intended only as an exercise aid in determining heart rate trends in general.

These guidelines will help you to plan your exercise program. For detailed exercise information, obtain a reputable book or consult your physician. Remember, proper nutrition and adequate rest are essential for successful results.

EXERCISE INTENSITY

Whether your goal is to burn fat or to strengthen your cardiovascular system, exercising at the proper intensity is the key to achieving results. You can use your heart rate as a guide to find the proper intensity level. The chart below shows recommended heart rates for fat burning and aerobic exercise.

165	155	145	140	130	125	115	♥
145	138	130	125	118	110	103	♥
125	120	115	110	105	95	90	♥
<hr/>							
20	30	40	50	60	70	80	

To find the proper intensity level, find your age at the bottom of the chart (ages are rounded off to the nearest ten years). The three numbers listed above your age define your “training zone.” The lowest number is the heart rate for fat burning, the middle number is the heart rate for maximum fat burning, and the highest number is the heart rate for aerobic exercise.

Burning Fat—To burn fat effectively, you must exercise at a low intensity level for a sustained period of time. During the first few minutes of exercise, your body uses *carbohydrate calories* for energy. Only after the first few minutes of exercise does your body begin to use stored *fat calories* for energy. If your goal is to burn fat, adjust the intensity of your exercise until your heart rate is near the lowest number in your training zone. For maximum fat burning, exercise with your heart rate near the middle number in your training zone.

Aerobic Exercise—If your goal is to strengthen your cardiovascular system, you must perform aerobic exercise, which is activity that requires large amounts of oxygen for prolonged periods of time. For aerobic exercise, adjust the intensity of your exercise until your heart rate is near the highest number in your training zone.

WORKOUT GUIDELINES

Warming Up—Start with 5 to 10 minutes of stretching and light exercise. A warm-up increases your body temperature, heart rate, and circulation in preparation for exercise.

Training Zone Exercise—Exercise for 20 to 30 minutes with your heart rate in your training zone. (During the first few weeks of your exercise program, do not keep your heart rate in your training zone for longer than 20 minutes.) Breathe regularly and deeply as you exercise—never hold your breath.

Cooling Down—Finish with 5 to 10 minutes of stretching. Stretching increases the flexibility of your muscles and helps to prevent post-exercise problems.

EXERCISE FREQUENCY

To maintain or improve your condition, complete three workouts each week, with at least one day of rest between workouts. After a few months of regular exercise, you may complete up to five workouts each week, if desired. Remember, the key to success is to make exercise a regular and enjoyable part of your everyday life.

SUGGESTED STRETCHES

The correct form for several basic stretches is shown at the right. Move slowly as you stretch—never bounce.

1. Toe Touch Stretch

Stand with your knees bent slightly and slowly bend forward from your hips. Allow your back and shoulders to relax as you reach down toward your toes as far as possible. Hold for 15 counts, then relax. Repeat 3 times. Stretches: Hamstrings, backs of knees, and back.

2. Hamstring Stretch

Sit with one leg extended. Bring the sole of the opposite foot toward you and rest it against the inner thigh of your extended leg. Reach toward your toes as far as possible. Hold for 15 counts, then relax. Repeat 3 times for each leg. Stretches: Hamstrings, lower back, and groin.

3. Calf/Achilles Stretch

With one leg in front of the other, reach forward and place your hands against a wall. Keep your back leg straight and your back foot flat on the floor. Bend your front leg, lean forward, and move your hips toward the wall. Hold for 15 counts, then relax. Repeat 3 times for each leg. To cause further stretching of the achilles tendons, bend your back leg as well. Stretches: Calves, achilles tendons, and ankles.

4. Quadriceps Stretch

With one hand against a wall for balance, reach back and grasp one foot with your other hand. Bring your heel as close to your buttocks as possible. Hold for 15 counts, then relax. Repeat 3 times for each leg. Stretches: Quadriceps and hip muscles.

5. Inner Thigh Stretch

Sit with the soles of your feet together and your knees outward. Pull your feet toward your groin as far as possible. Hold for 15 counts, then relax. Repeat 3 times. Stretches: Quadriceps and hip muscles.

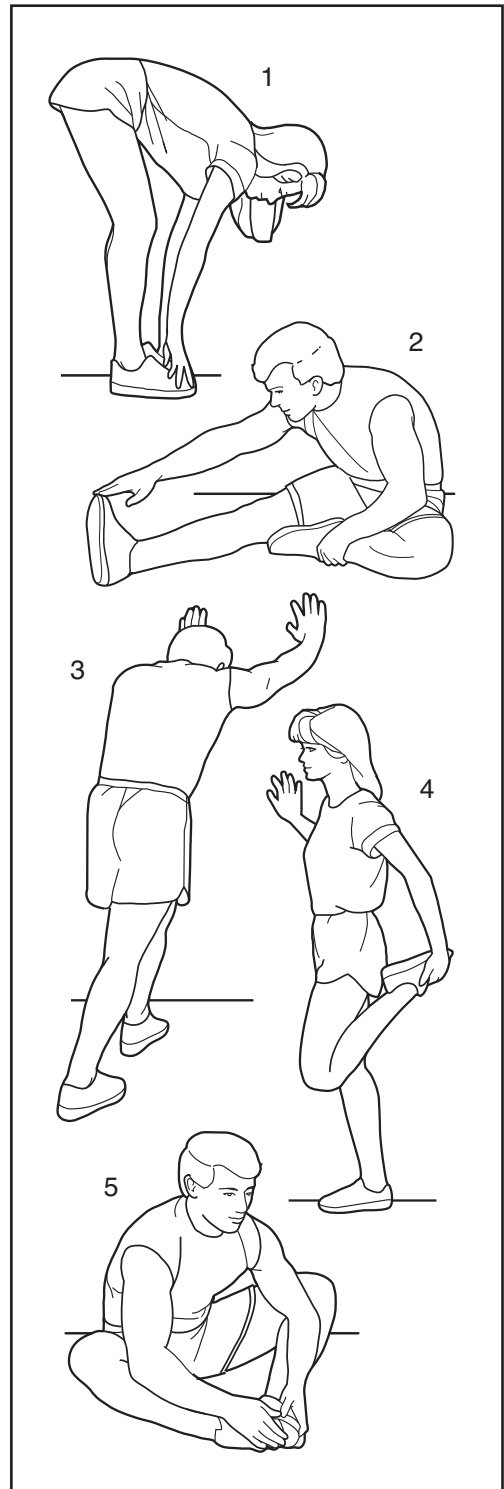

PART LIST—Model No. PFEL57908.1

R0509A

Key No.	Qty.	Description	Key No.	Qty.	Description
1	1	Frame	51	2	Roller
2	1	Base	52	2	Pedal Arm Cap
3	1	Ramp	53	8	Axle Cover
4	1	Upright	54	2	16mm Wave Washer
5	3	M4 x 19mm Screw	55	2	Crank Arm Spacer
6	1	Front Stabilizer	56	2	Pedal Bracket Spacer
7	1	Console	57	4	Pedal Arm Bushing
8	1	Left Pulse Bar	58	1	Right Pedal Arm
9	1	Right Pulse Bar	59	1	Right Roller Arm
10	1	Track Cover	60	1	Right Handlebar Leg
11	1	Left Latch Cover	61	1	Right Handlebar
12	1	Right Latch Cover	62	2	Handlebar Cap
13	1	Latch Button	63	2	Pulse Sensor Assembly
14	1	Latch Cable	64	1	Right Pedal Bracket
15	4	Cable Pulley	65	6	M6 x 25mm Flat Head Screw
16	1	Latch Spring	66	4	19mm Wave Washer
17	1	Latch Pin	67	2	Outer Handlebar Cover
18	1	Crank	68	2	Inner Handlebar Cover
19	1	Pulley	69	2	M4 x 16mm Reed Switch Screw
20	2	Crank Arm	70	2	Inner Pivot Bushing
21	13	M4 x 16mm Flange Screw	71	2	Disc
22	1	Idler	72	2	Disc Mount
23	1	C-magnet	73	1	Left Shield
24	1	Motor Bracket	74	1	Right Shield
25	1	Resistance Motor	75	1	Shield Cover
26	1	Resistance Rod	76	4	V-clip
27	1	Resistance Disc	77	2	Roller Spacer
28	1	Flywheel	78	2	Key
29	1	Flywheel Axle	79	1	Long Magnet Spacer
30	4	Stabilizer Bushing	80	1	Short Magnet Spacer
31	1	Stabilizer Axle	81	2	M10 Shoulder Screw
32	2	Stabilizer Cap	82	15	M8 x 19mm Patch Screw
33	1	Foot	83	9	M8 Split Washer
34	2	Wheel	84	2	M8 x 80mm Patch Screw
35	1	Pivot Axle	85	2	M6 x 12mm Hex Patch Screw
36	4	Pivot Bushing	86	2	M8 x 48mm Hex Bolt
37	1	Water Bottle Holder	87	4	M8 x 13mm Screw
38	1	Reed Switch	88	1	M8 x 38mm Hex Screw
39	2	Clamp	89	1	M10 x 22mm Bolt
40	6	R12 Bearing	90	1	M8 x 80mm Shoulder Bolt
41	2	Flywheel Bearing	91	2	M10 Fender Washer
42	4	Snap Ring	92	3	M10 Locknut
43	2	Magnet	93	4	M4 x 12mm Bolt
44	1	Left Pedal Arm	94	4	M4 Locknut
45	1	Left Roller Arm	95	2	M10 Washer
46	1	Left Handlebar Leg	96	8	M8 x 38mm Bolt
47	1	Left Handlebar	97	8	M8 x 19mm Patch Screw
48	1	Left Pedal Bracket	98	8	M8 x 25mm Washer
49	1	Left Pedal	99	4	M10 x 45mm Patch Screw
50	1	Left Pedal Insert	100	2	M10 x 60mm Bolt

Key No.	Qty.	Description	Key No.	Qty.	Description
101	2	M8 x 20mm Washer	112	1	Power Adapter
102	12	M8 Locknut	113	1	Drive Belt
103	1	M3.5 x 12mm Flat Head Screw	114	2	Foam Grip
104	16	M4 x 16mm Screw	115	1	Right Pedal
105	8	M4 x 12mm Screw	116	1	Right Pedal Insert
106	1	M4 x 16mm Bright Screw	117	2	Pulse Wire
107	4	Roller Arm Bushing	118	2	Upper Bushing
108	10	M6 x 13mm Screw	*	–	Assembly Tool
109	2	M6 Washer	*	–	Grease Packet
110	1	Upper Wire Harness	*	–	User's Manual
111	1	Lower Wire Harness			

Note: Specifications are subject to change without notice. See the back cover of this manual for information about ordering replacement parts. *These parts are not illustrated.

EXPLODED DRAWING A—Model No. PFEL57908.1

R0509A

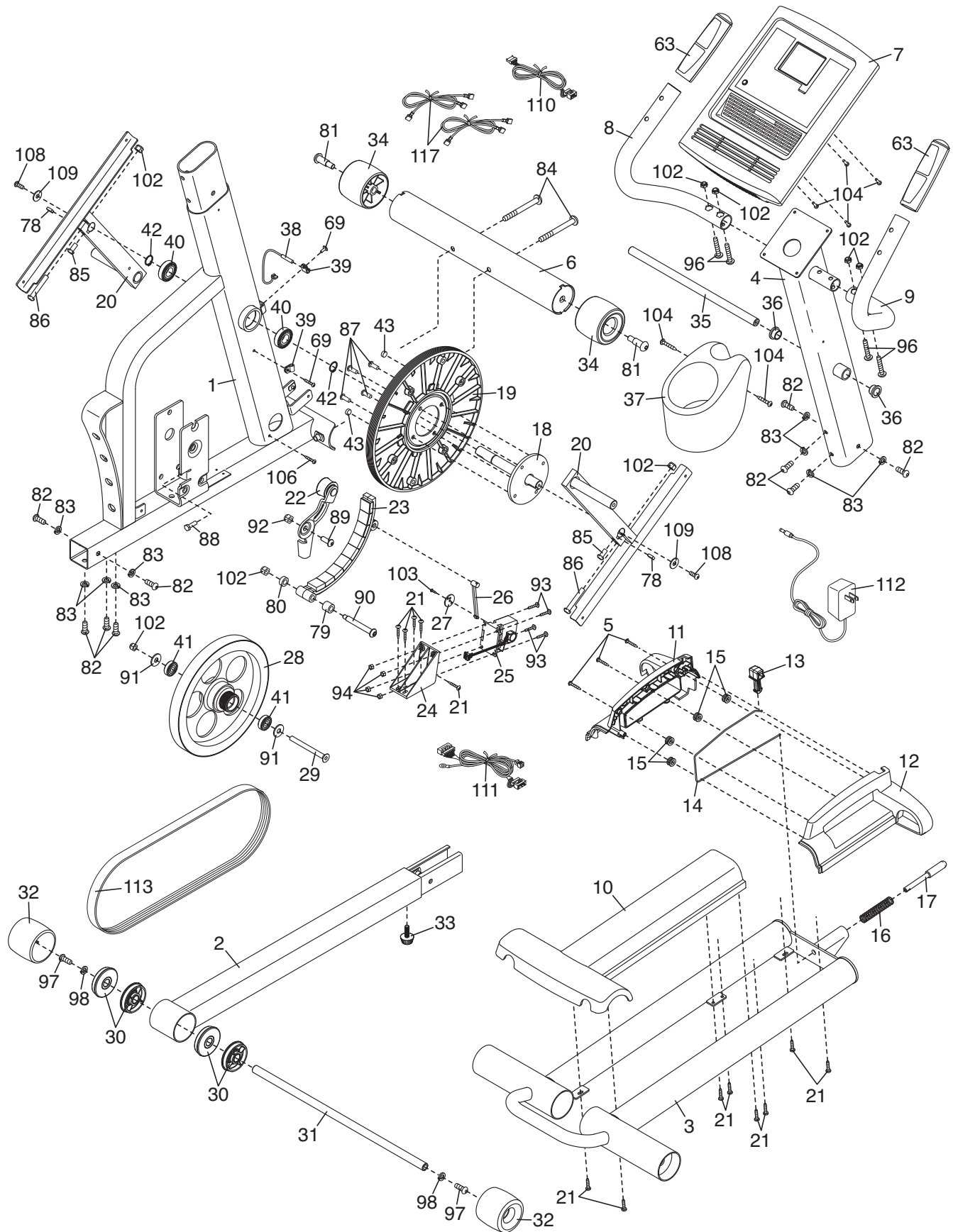

EXPLODED DRAWING B—Model No. PFEL57908.1

R0509A

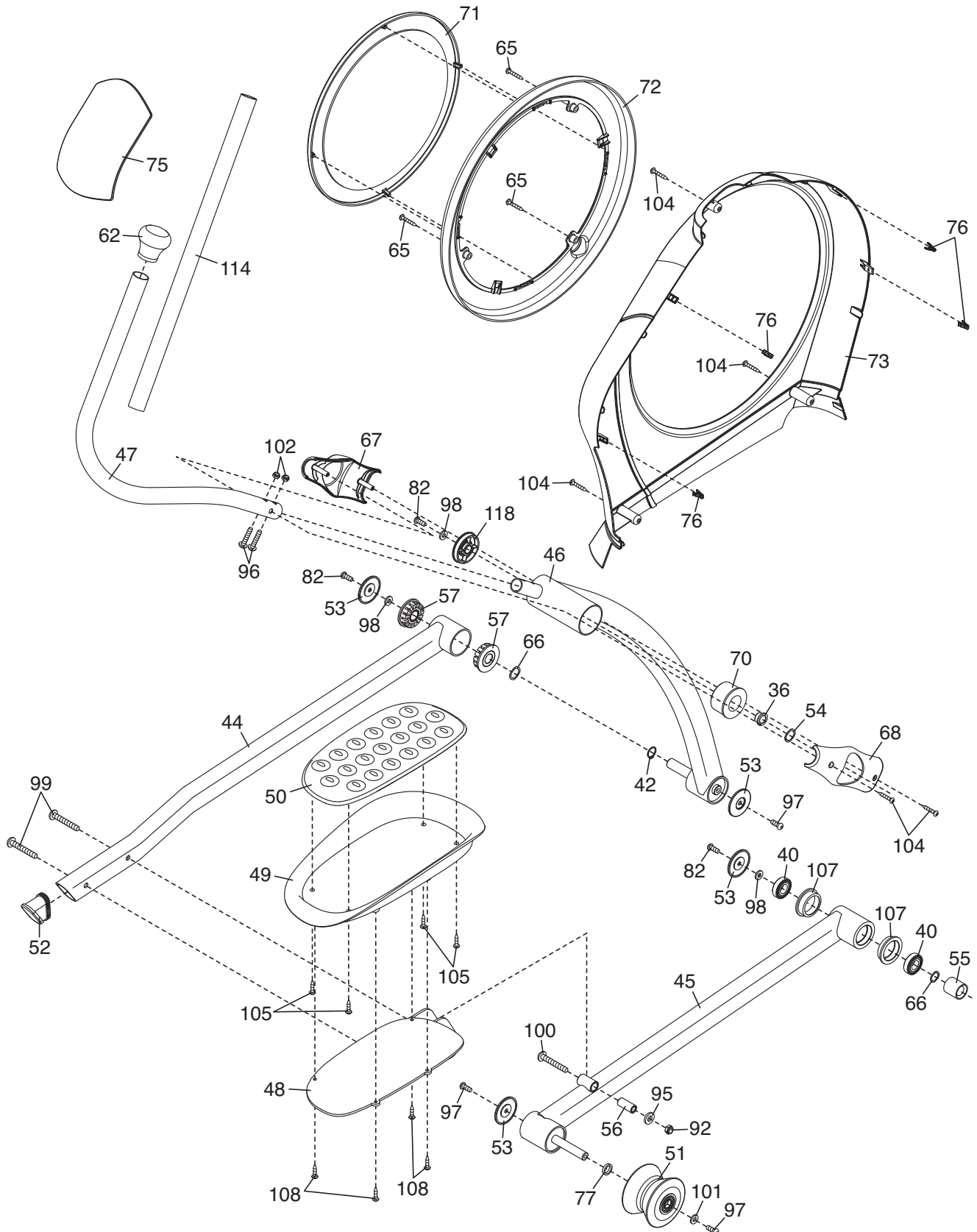

EXPLODED DRAWING C—Model No. PFEL57908.1

R0509A

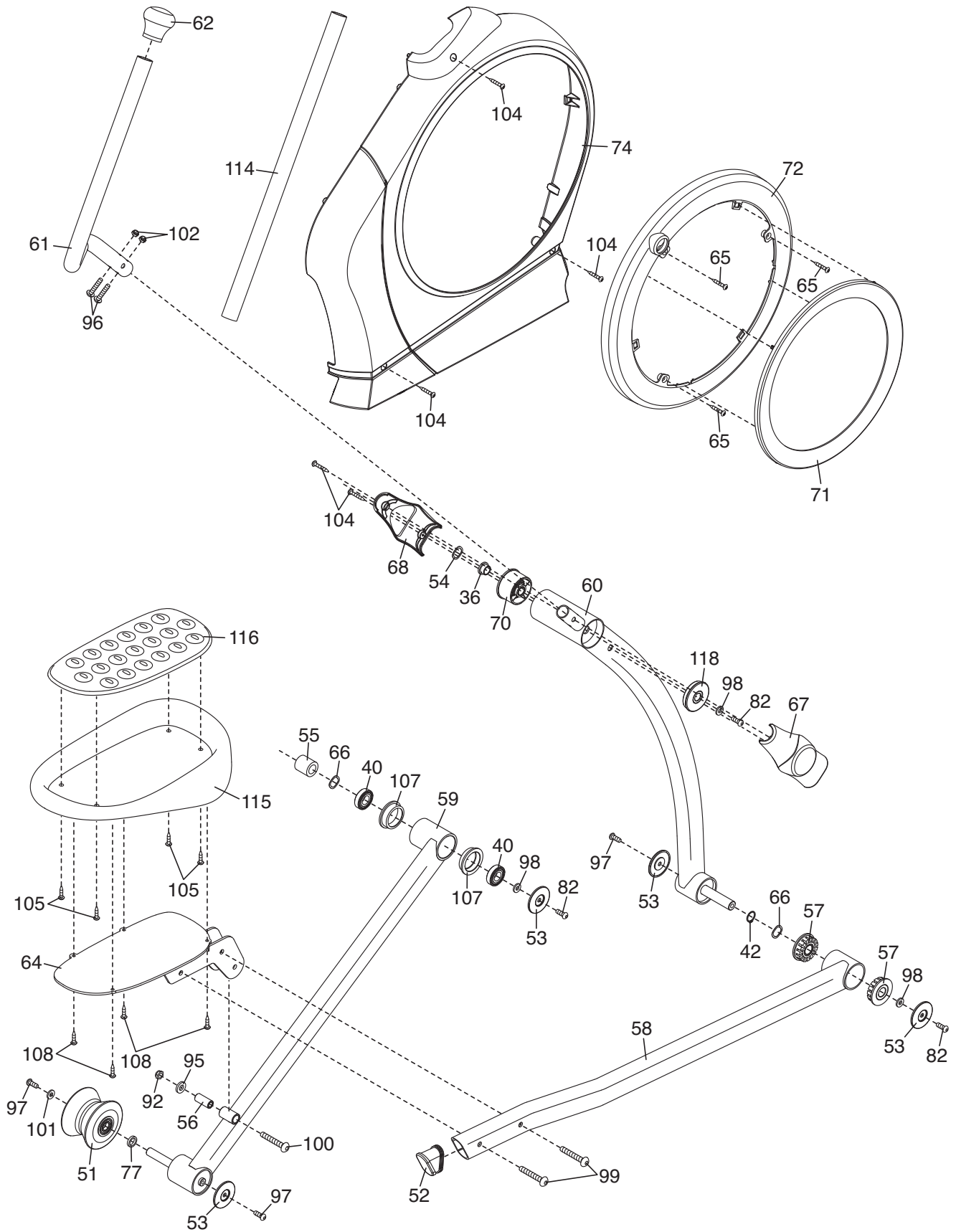

ORDERING REPLACEMENT PARTS

To order replacement parts, please see the front cover of this manual. To help us assist you, be prepared to provide the following information when contacting us:

- the model number and serial number of the product (see the front cover of this manual)
- the name of the product (see the front cover of this manual)
- the key number and description of the replacement part(s) (see the PART LIST and the EXPLODED DRAWING near the end of this manual)

LIMITED WARRANTY

ICON Health & Fitness, Inc. (ICON) warrants this product to be free from defects in workmanship and material, under normal use and service conditions. The frame is warranted for a lifetime. The resistance mechanism is warranted for seven (7) years from the date of purchase. Parts and labor are warranted for one (1) year from the date of purchase.

This warranty extends only to the original purchaser. ICON's obligation under this warranty is limited to repairing or replacing, at ICON's option, the product through one of its authorized service centers. All repairs for which warranty claims are made must be preauthorized by ICON. If the product is shipped to a service center, freight charges to and from the service center will be the customer's responsibility. For replacement parts shipped while the product is under warranty, the customer will be responsible for a minimal handling charge. For in-home service, the customer will be responsible for a minimal trip charge. This warranty does not extend to any damage to a product caused by or attributable to freight damage, abuse, misuse, improper or abnormal usage, or repairs not provided by an ICON authorized service center; products used for commercial or rental purposes; or products used as store display models. No other warranty beyond that specifically set forth above is authorized by ICON.

ICON is not responsible or liable for indirect, special, or consequential damages arising out of or in connection with the use or performance of the product; damages with respect to any economic loss, loss of property, loss of revenues or profits, loss of enjoyment or use, or costs of removal or installation; or other consequential damages of whatsoever nature. Some states do not allow the exclusion or limitation of incidental or consequential damages. Accordingly, the above limitation may not apply to you.

The warranty extended hereunder is in lieu of any and all other warranties, and any implied warranties of merchantability or fitness for a particular purpose are limited in their scope and duration to the terms set forth herein. Some states do not allow limitations on how long an implied warranty lasts. Accordingly, the above limitation may not apply to you.

This warranty gives you specific legal rights. You may also have other rights that vary from state to state.

ICON Health & Fitness, Inc., 1500 S. 1000 W., Logan, UT 84321-9813