

PRO-FORM[®]

REFLEXSTEP

Model No. PFEVEL93407.0

Serial No. _____

Write the serial number in the space above for reference.

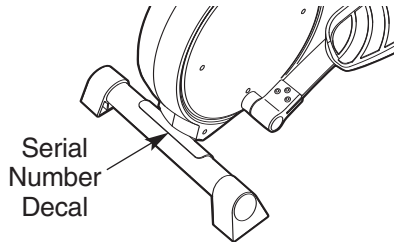

USER'S MANUAL

QUESTIONS?

As a manufacturer, we are committed to providing complete customer satisfaction. If you have questions, or if there are missing parts, please contact us:

Call: 08457 089 009

Outside UK: 0 (44) 113 3877133

Fax: 0 (44) 113 3877125

Website: www.iconsupport.eu
E-mail: csuk@iconeurope.com

Write:

ICON Health & Fitness, Ltd.
Unit 4
Revie Road Industrial Estate
Revie Road, Beeston
Leeds, LS11 8JG,
UK

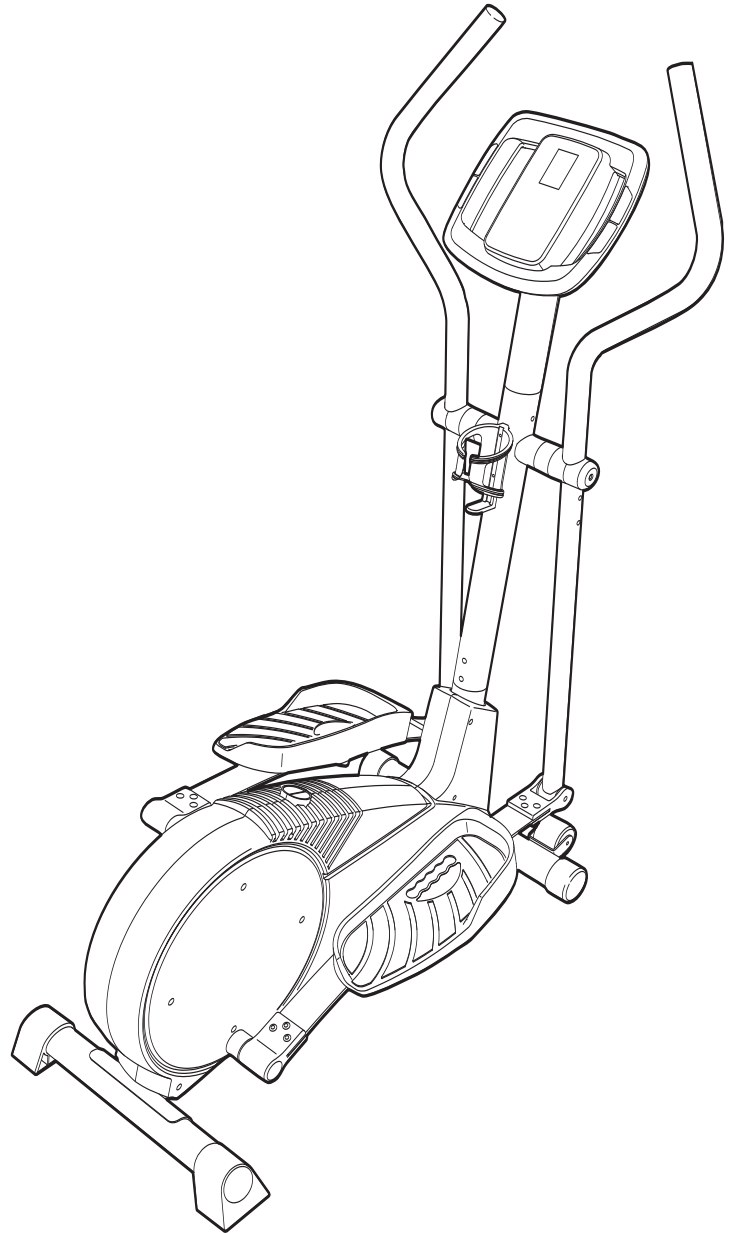

CAUTION

Read all precautions and instructions in this manual before using this equipment. Keep this manual for future reference.



Visit our website at

www.iconeurope.com

TABLE OF CONTENTS

WARNING DECAL PLACEMENT2
IMPORTANT PRECAUTIONS3
BEFORE YOU BEGIN4
ASSEMBLY5
HOW TO USE THE ELLIPTICAL EXERCISER10
MAINTENANCE AND TROUBLESHOOTING20
EXERCISE GUIDELINES22
PART LIST26
EXPLODED DRAWING27
ORDERING REPLACEMENT PARTSBack Cover

WARNING DECAL PLACEMENT

The warning decal shown here has been applied in the location shown. **If the decal is missing or illegible, call the telephone number on the front cover of this manual and request a free replacement decal. Apply the decal in the location shown.**
Note: The decal may not be shown at actual size.

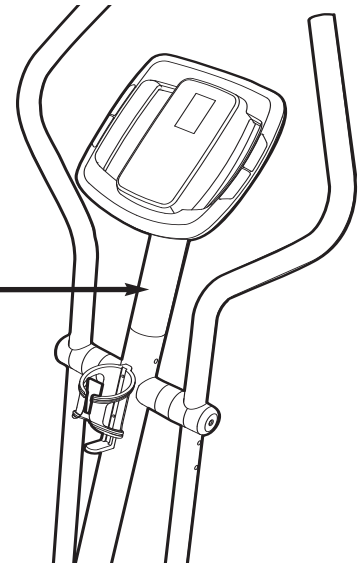
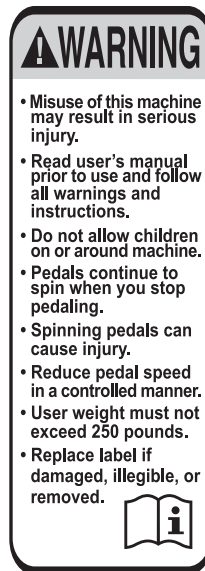

IMPORTANT PRECAUTIONS

⚠️ WARNING: To reduce the risk of serious injury, read all important precautions and instructions in this manual and all warnings on your elliptical exerciser before using your elliptical exerciser. ICON assumes no responsibility for personal injury or property damage sustained by or through the use of this product.

1. Before beginning any exercise program, consult your physician. This is especially important for persons over the age of 35 or persons with pre-existing health problems.
2. It is the responsibility of the owner to ensure that all users of the elliptical exerciser are adequately informed of all precautions.
3. Your elliptical exerciser is intended for home use only. Do not use your elliptical exerciser in a commercial, rental, or institutional setting.
4. Keep your elliptical exerciser indoors, away from moisture and dust. Place your elliptical exerciser on a level surface, with a mat beneath it to protect the floor or carpet. Make sure that there is enough clearance around your elliptical exerciser to mount, dismount, and use it.
5. Inspect and properly tighten all parts regularly. Replace any worn parts immediately.
6. Keep children under age 12 and pets away from your elliptical exerciser at all times.
7. Your elliptical exerciser should not be used by persons weighing more than 250 lbs. (113 kg).
8. Wear appropriate exercise clothes when exercising; do not wear loose clothes that could become caught on your elliptical exerciser. Always wear athletic shoes for foot protection.
9. Hold the handgrip pulse sensor or the handlebars when mounting, dismounting, or using your elliptical exerciser.
10. Keep your back straight while using your elliptical exerciser; do not arch your back.
11. The pulse sensor is not a medical device. Various factors, including the user's movement, may affect the accuracy of heart rate readings. The pulse sensor is intended only as an exercise aid in determining heart rate trends in general.
12. When you stop exercising, allow the pedals to slowly come to a stop.
13. If you feel pain or dizziness while exercising, stop immediately and cool down.
14. Use your elliptical exerciser only as described in this manual.

BEFORE YOU BEGIN

Congratulations for selecting the new PROFORM® REFLEX STEP elliptical exerciser. The REFLEX STEP is a smooth exerciser that moves your feet in a natural elliptical path, minimizing the impact on your knees and ankles. And the unique REFLEX STEP features adjustable resistance and an easy-to-use console to help you get the most from your exercise.



For your benefit, read this manual carefully before you use the elliptical exerciser. If you have ques-

tions after reading this manual, please see the front cover of this manual. To help us assist you, note the product model number and serial number before contacting us. The model number and the location of the serial number decal are shown on the front cover of this manual.

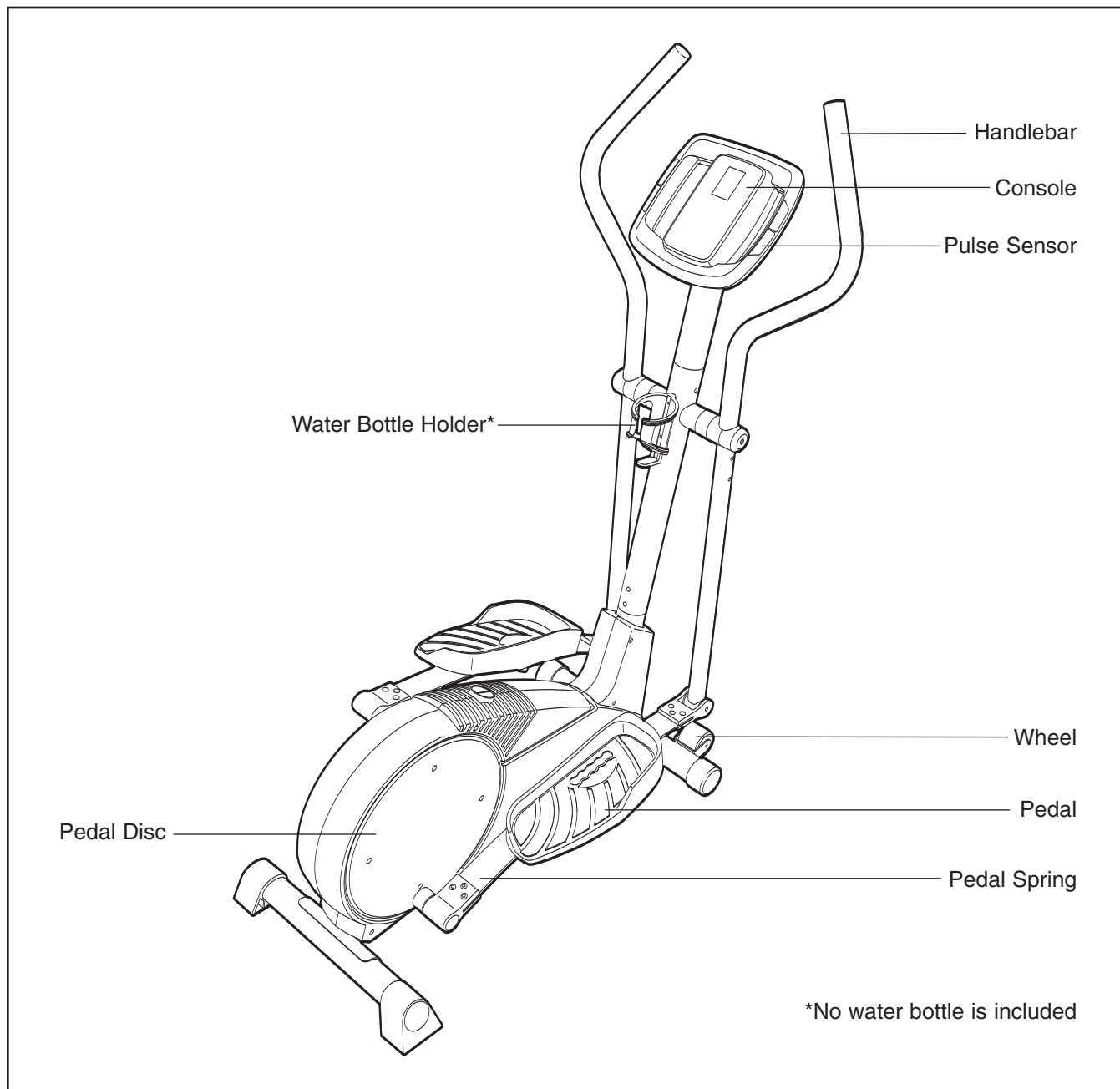
Before reading further, please familiarize yourself with the parts that are labeled in the drawing below.

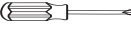

ASSEMBLY

Assembly requires two persons. Place all parts of the elliptical exerciser in a cleared area and remove the packing materials. Do not dispose of the packing materials until assembly is completed. **Assembly requires the included hex keys and your own Phillips screwdriver** , **adjustable wrench** , and **rubber mallet** .

Use the drawings below to identify the small parts used for assembly. The number in parentheses below each drawing is the key number of the part, from the PART LIST near the end of this manual. The number following the key number is the quantity needed for assembly. **Note: Some small parts may have been preassembled. If a part is not in the hardware kit, check to see if it has been preassembled.**

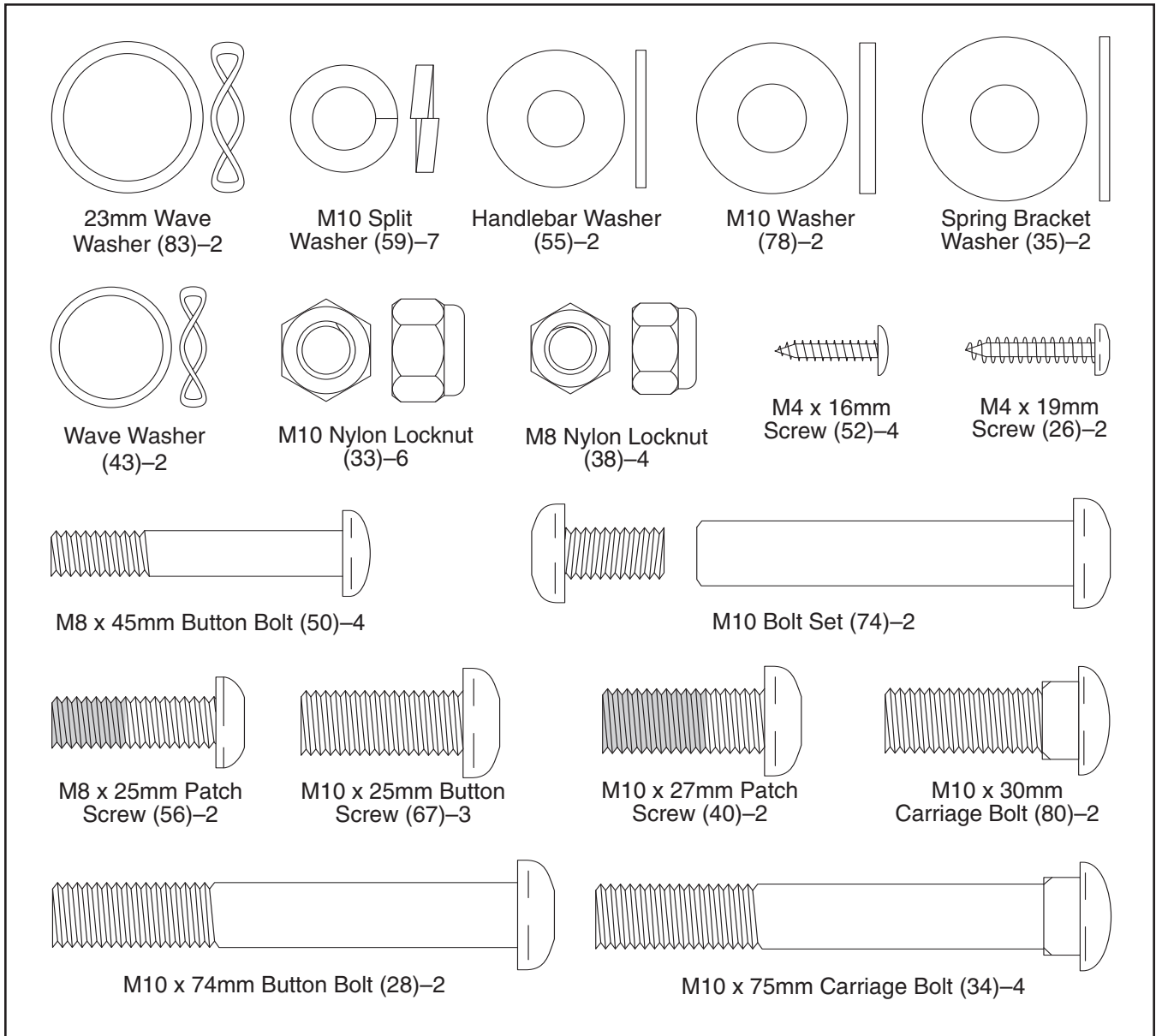

1.

To make assembly easier, read the information on page 5 before you begin assembling the elliptical exerciser.

Identify the Front Stabilizer (10), which has Wheels (22) attached. **Make sure that the Front Stabilizer is turned so the Wheels are not touching the floor.** While another person lifts the front of the Frame (1), attach the Front Stabilizer to the Frame with two M10 x 75mm Carriage Bolts (34) and two M10 Nylon Locknuts (33).

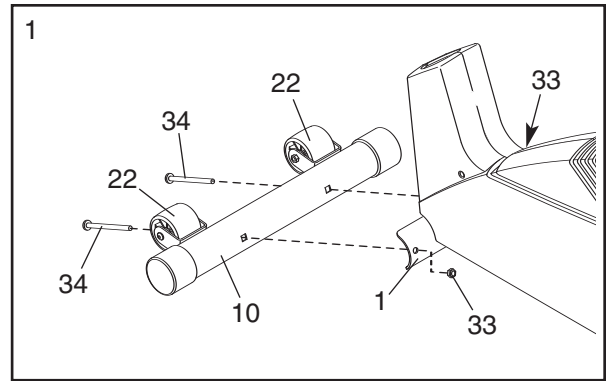

2. While another person lifts the back of the Frame (1), attach the Rear Stabilizer (9) to the Frame with two M10 x 75mm Carriage Bolts (34) and two M10 Nylon Locknuts (33).

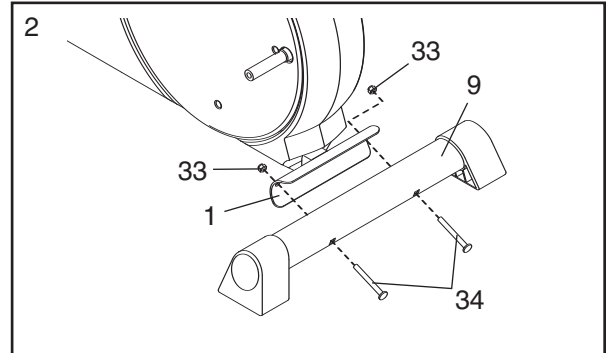

3. While another person holds the Upright (2) near the Frame (1), connect the Extension Wire Harness (44) to the Wire Harness (79). **Carefully pull the upper end of the Extension Wire Harness to remove any slack,** and slide the Upright onto the Frame. Attach the Upright with two M10 x 74mm Button Bolts (28), two M10 Split Washers (59), and two M10 Nylon Locknuts (33). **Be careful avoid pinching the Wire Harnesses.**

While another person holds the Upright Extension (73) near the Upright (2), insert the upper end of the Extension Wire Harness (44) through the Upright Extension (73).

Hold the upper end of the Extension Wire Harness (44) and insert the Upright Extension (73) into the Upright (2). Attach the Upright Extension with three M10 x 25mm Button Screws (67) and three M10 Split Washers (59). **Be careful avoid pinching the Extension Wire Harness. Make sure that the Nylon Locknuts are inside the hexagonal holes.**

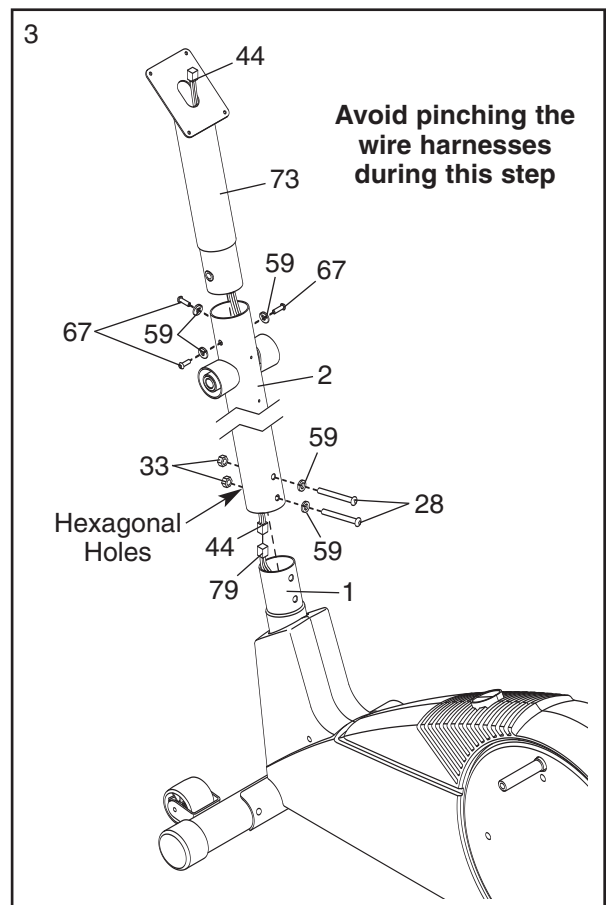

4. The Console (23) requires four “AA” batteries; alkaline batteries are recommended. **IMPORTANT: If the elliptical exerciser has been exposed to cold temperatures, allow it to warm to room temperature before inserting batteries into the Console. If you do not do this, the console displays or other electronic components may become damaged.** Remove the battery cover and insert four batteries into the battery compartment; **make sure that the batteries are oriented as shown by the diagrams inside the battery compartment.** Then, reattach the battery cover.

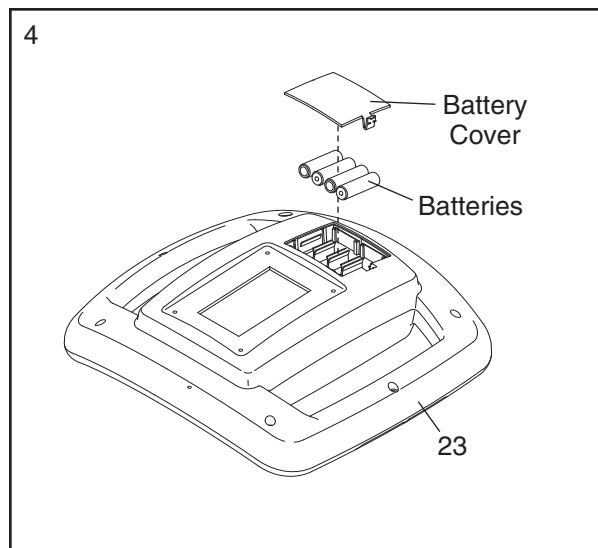

5. While another person holds the Console (23) near the Upright Extension (73), connect the console wire harness to the Extension Wire Harness (44). Insert the excess wire harness into the Upright Extension.

Attach the Console (23) to the Upright Extension (73) with four M4 x 16mm Screws (52). **Be careful to avoid pinching the wire harnesses.**

Attach the Water Bottle Holder (65) to the Upright (2) with two M4 x 19mm Screws (26).

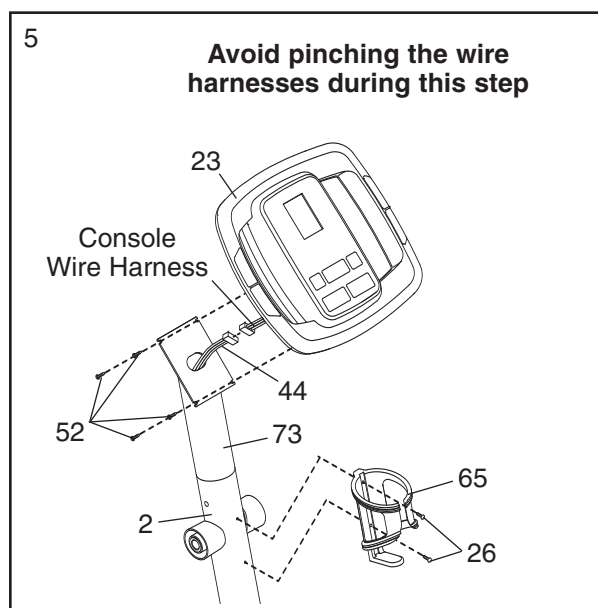

6. Identify the left Pedal Spring (11), which is marked with an “L” sticker. Attach the Left Pedal (13) to the left Pedal Spring with an M10 x 30mm Carriage Bolt (80), an M10 Washer (78), an M10 Split Washer (59), and a Pedal Knob (81) as shown. Note: The Left Pedal can be attached in several positions using the five positions in the Left Pedal and the three holes in the Pedal Spring.

Attach the Right Pedal (not shown) in the same way.

Make sure that both Pedals are in the same hole and in the same pedal position.

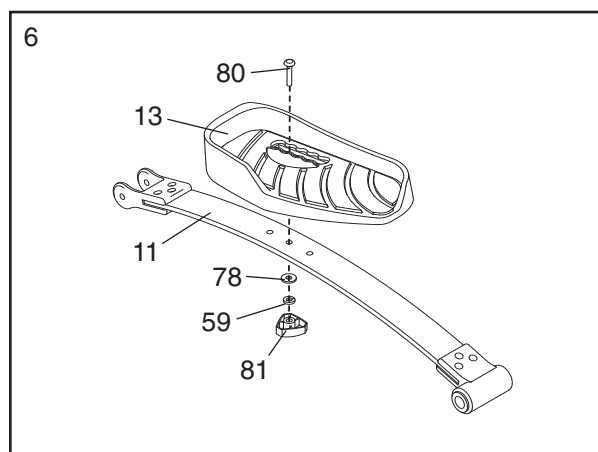

7. Identify the Left Handlebar (6), which is marked with a "L" sticker. Insert the Left Handlebar into one of the Handlebar Legs (5); **make sure that the Handlebar Leg is turned so the hexagonal holes are on the indicated side.** Attach the Left Handlebar with two M8 x 45mm Button Bolts (50) and two M8 Nylon Locknuts (38). **Make sure that the Nylon Locknuts are inside the hexagonal holes. Do not tighten the Button Bolts yet.**

Apply a generous amount of the included grease to the Pivot Axle (7). Then apply grease to two Wave Washers (43).

Insert the Pivot Axle (7) into the Upright (2), and center the Pivot Axle. Turn a Handlebar Spacer (47) so that the small arrow on the Handlebar Spacer points toward the floor, and slide the Handlebar Spacer onto the Left Handlebar (6). Next, slide a Wave Washer (43) onto the Pivot Axle.

Slide the Left Handlebar (6) onto the Pivot Axle (7). Attach the Left Handlebar with an M8 x 25mm Patch Screw (56) and a Handlebar Washer (55). Then, press the tabs on a Handlebar Cap (46) into the Handlebar Spacer (47).

Assemble the Right Handlebar (8) and the other Handlebar Leg (5) in the same way.

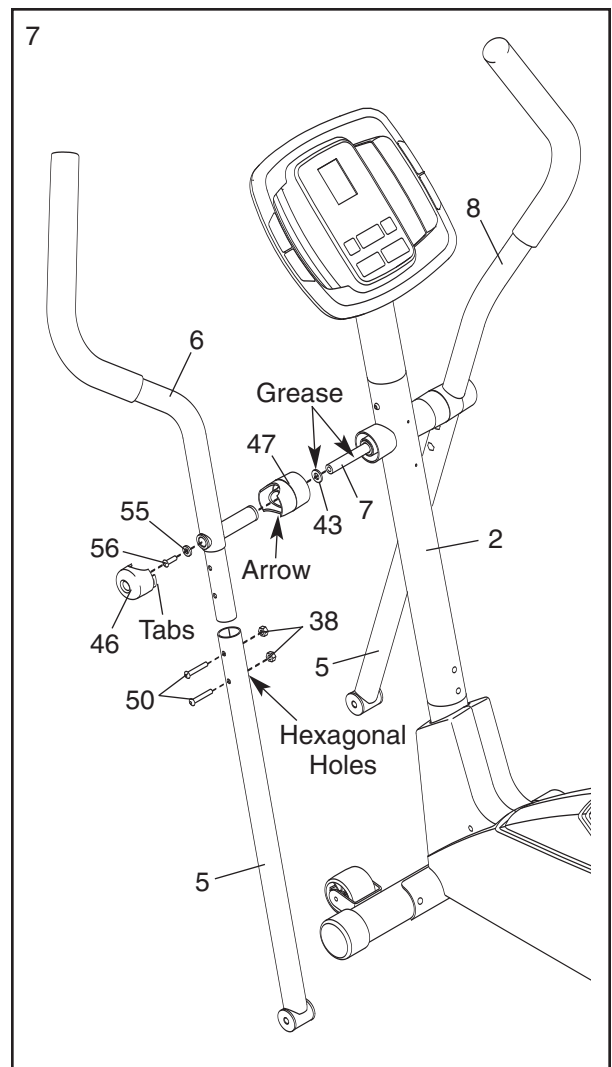

8. Identify the Left Rear Spring Bracket (12) on the left Pedal Spring (11). Apply a small amount of grease inside the Pedal Arm Bushings (37) in the Left Rear Spring Bracket and to the axle on the left Disc Crossbar (16). Slide a Spring Spacer (63) and a 23mm Wave Washer (83) onto the axle; **make sure that the Spring Spacer is turned so the flat side is facing the elliptical exerciser**. Next, slide the Left Rear Spring Bracket onto the axle. Slide a Spring Bracket Washer (35) onto an M10 x 27mm Patch Screw (40), and tighten the Patch Screw into the axle.

Next, hold the lower end of the left Handlebar Leg (5) inside the Front Spring Bracket (76) on the left Pedal Spring (11). Apply grease to an M10 Bolt Set (74). Attach the Handlebar Leg to the Front Spring Bracket with the Bolt Set. **Do not overtighten the Bolt Set; the Handlebar Leg must pivot freely.**

Attach the right Pedal Spring (not shown) to the right side of the elliptical exerciser in the same way.

See step 7. Tighten the M8 x 45mm Button Bolts (50).

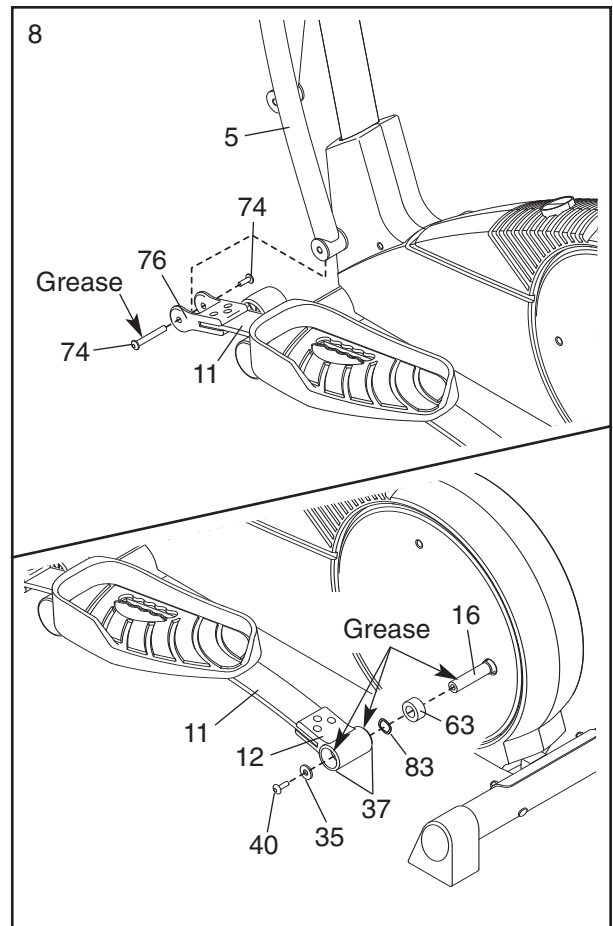

9. **Make sure that all parts of the elliptical exerciser are properly tightened.** Note: Some hardware may be left over after assembly is completed. To protect the floor or carpet from damage, place a mat under the elliptical exerciser.

HOW TO USE THE ELLIPTICAL EXERCISER

HOW TO MOVE THE ELLIPTICAL EXERCISER

Stand behind the elliptical exerciser, hold the Rear Stabilizer (9) firmly, and lift the elliptical exerciser until it can be moved on the Wheels (22). Carefully move the elliptical exerciser to the desired location, and then lower it. **To decrease the possibility of injury, bend your legs and keep your back straight as you lift the Rear Stabilizer; make sure to lift with your legs rather than with your back.**

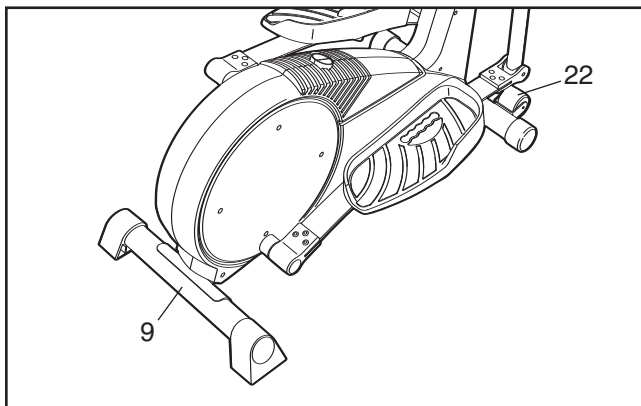

HOW TO LEVEL THE ELLIPTICAL EXERCISER

If the elliptical exerciser rocks slightly on your floor, turn one or both of the leveling feet under the rear stabilizer until the rocking motion is eliminated.

HOW TO ADJUST THE PEDALS

The motion of the elliptical exerciser is determined by the positions of the pedals. To adjust each pedal, first remove the pedal knob beneath the pedal. Slide the pedal forward or backward, and then reattach the pedal using one of the five holes in the pedal and one of the three holes in the pedal spring. Make sure that both pedals are in the same position.

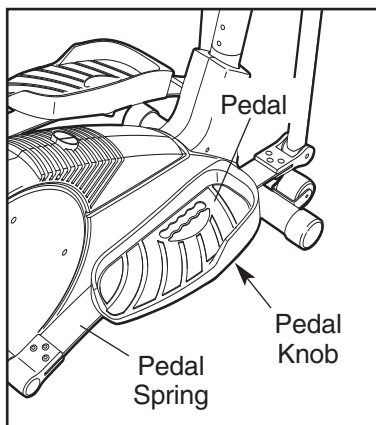

HOW TO USE THE HANDLEBARS

The handlebars are designed to add upper-body exercise to your workouts. As you exercise, push and pull the handlebars to work your arms, shoulders, and back.

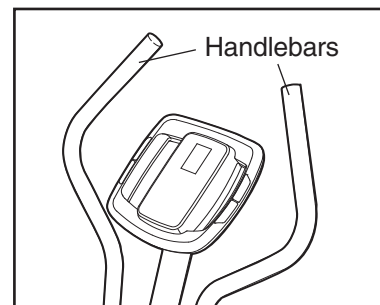

HOW TO EXERCISE ON THE ELLIPTICAL EXERCISER

To mount the elliptical exerciser, hold the handlebars and step onto the pedal that is in the lowest position. Then, step onto the other pedal. Push the pedals until they begin to move with a continuous motion. **Note: The pedal discs can turn in either direction. It is recommended that you move the pedal discs in the direction shown by the arrow; however, for variety, you may turn the pedal discs in the opposite direction.**

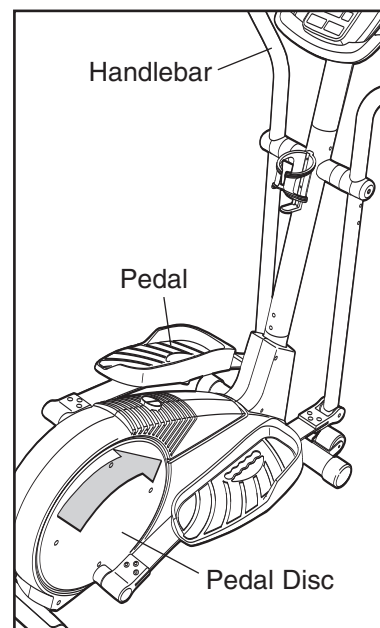

To dismount the elliptical exerciser, wait until the pedals come to a complete stop. **Note: The elliptical exerciser does not have a free wheel; the pedals will continue to move until the flywheel stops.** When the pedals are stationary, step off the highest pedal first. Then, step off the lower pedal.

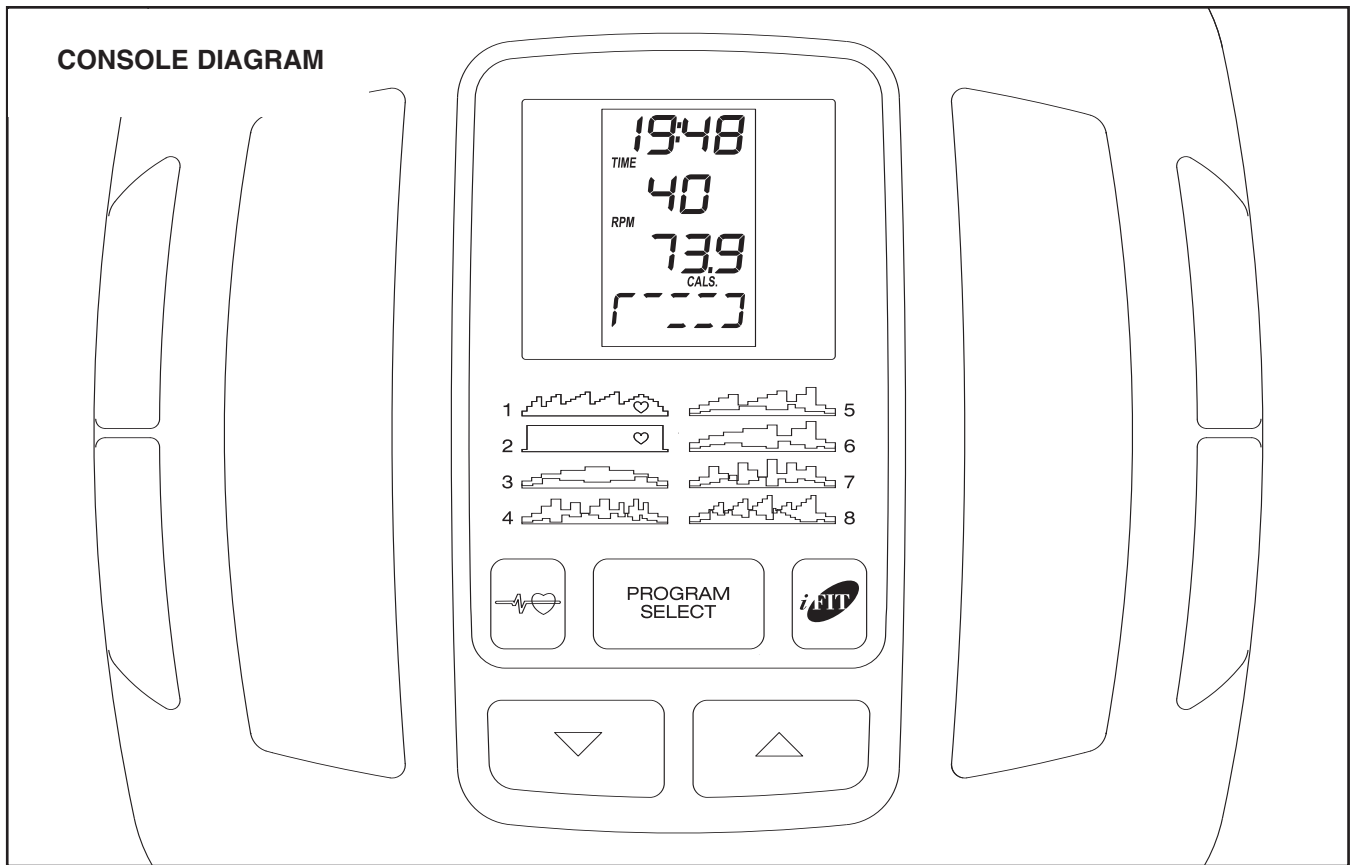

FEATURES OF THE CONSOLE

The console offers a selection features designed to make your workouts more effective. When you use the manual mode of the console, you can change the resistance of the pedals with the touch of a button. As you exercise, the console will provide continuous exercise feedback. You can even monitor your heart rate using the handgrip pulse sensor or the optional chest pulse sensor. (For information about the optional chest pulse sensor, see page 20.)

The console features six smart programs that automatically change the resistance of the pedals and prompt you to vary your pedaling pace while guiding you through an effective workout.

The console also offers two heart rate programs that automatically control the resistance of the pedals and prompt you to maintain a constant pedaling pace to keep your heart rate near target heart rate settings during your workouts.

In addition, the console also features iFIT.com interactive technology. Having iFIT.com interactive technology is like having a personal trainer in your home. Using a stereo audio cable, you can connect the elliptical exerciser to your home stereo, portable stereo,

computer, or VCR and play special iFIT.com CD and video programs (iFIT.com CDs and videocassettes are available separately). iFIT.com CD and video programs automatically control the resistance of the pedals and prompt you to vary your pace as a personal trainer coaches you through every step of your workout. High-energy music provides added motivation. **To purchase iFIT.com CDs and videocassettes, visit our website at www.iconeurope.com.**

With the elliptical exerciser connected to your computer, you can also go to our website at www.iFIT.com and access programs directly from the Internet. **Explore www.iFIT.com for more information.**

To use the manual mode of the console, follow the steps beginning on page 12. **To use a smart program,** see page 13. **To use a heart rate program,** see page 14. **To use an iFIT.com CD or video program,** see page 18. **To use a program directly from our website,** see page 19.

Before using the console, make sure that batteries are installed (see assembly step 4 on page 7). If there is a sheet of clear plastic on the display, remove the plastic.

HOW TO USE THE MANUAL MODE

1. Turn on the console.

To turn on the console, press any button or begin pedaling. The display will light and the console will be ready for use.

2. Select the manual mode.

Each time you turn on the console, the manual mode will be selected. If you have selected a program, reselect the manual mode by pressing any of the Programs buttons repeatedly until zeroes appear in the display.



3. Begin pedaling and change the resistance of the pedals as desired.

As you pedal, change the resistance of the pedals by pressing the Increase and Decrease buttons. There are ten resistance levels. Note: After you press the buttons, it will take a moment for the pedals to reach the selected resistance level.

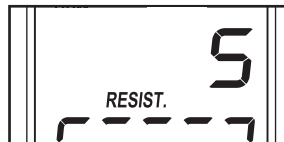

4. Follow your progress with the display.

The first section of the display will show the elapsed time and the distance (total number of revolutions) that you have pedaled.

The display will change modes every few seconds. Note: When you select a program, with the exception of the second heart rate program, the display will show the time remaining in the program instead of the elapsed time.



The second section of the display will show your pedaling pace, in revolutions per minute (rpm).



The third section of the display will show the approximate number of calories you have burned and the resistance level of the pedals. The display will change modes every few seconds. The display will also show your heart rate when you use the handgrip pulse sensor.



The last section of the display will show a track representing 640 revolutions. As you exercise, indicators will appear in succession around the track until the entire track appears. The track will then disappear and the indicators will again begin to appear in succession.

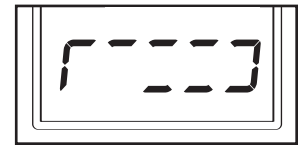

5. Measure your heart rate if desired.

If there are sheets of clear plastic on the metal contacts on the handgrip pulse sensor, remove the plastic.

Next, hold the handgrip pulse sensor with your palms resting on the metal contacts. **Avoid moving your hands or gripping the contacts too tightly.** When your pulse is detected, a heart-shaped symbol will flash in the display each time your heart beats and then your heart rate will be shown. For the most accurate heart rate reading, hold the contacts for at least 15 seconds.

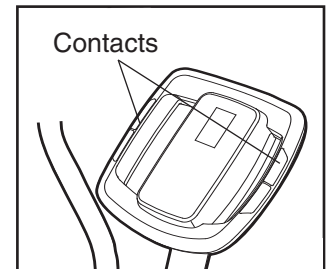

6. When you are finished exercising, the console will turn off automatically.

If the pedals do not move for a few seconds, the time will begin to flash in the display and the console will pause. If the pedals do not move for a few minutes and no buttons are pressed, the console will turn off and the display will be reset.

HOW TO USE A SMART PROGRAM

1. Turn on the console.

To turn on the console, press any button or begin pedaling. The display will light and the console will be ready for use.

2. Select a smart program.

To select a smart program, press the Program Select button repeatedly until P3, P4, P5, P6, P7, or P8 appears in the display.

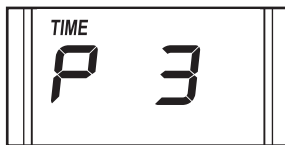

The first section of the display will show how long the program will last.

3. Begin pedaling to start the program.

Each program is divided into 30 one-minute segments. One resistance level and one pace setting are programmed for each segment. Note: The same resistance level and/or pace setting may be programmed for two or more consecutive segments.

Whenever the resistance is about to change, the resistance level will flash in the display for a few seconds. The resistance of the pedals will then automatically change to the resistance level programmed for the next segment. Note: If the resistance level is too low or too high, you can override it by pressing the Increase and Decrease buttons. However, when the current segment ends, the resistance will automatically change to the resistance level programmed for the next segment.

As you exercise, the display will prompt you to keep your pedaling pace near the pace setting for the current segment. When the

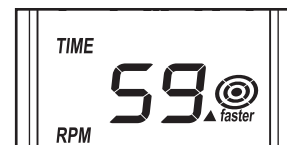

word “faster” appears in the display, increase your pace. When the word “slower” appears, decrease your pace. When the center of the target flashes, maintain your current pace.

IMPORTANT: The pace settings are intended only to provide motivation. Your actual pace may be slower than the pace settings. Make sure to pedal at a pace that is comfortable for you.

If the resistance level for the current segment is too high or too low, you can manually override the level by pressing the decrease and increase buttons. **IMPORTANT: When the current segment of the program ends, the pedals will automatically adjust to the resistance setting for the next segment.**

If you stop pedaling for several seconds, the time will begin to flash in the display. To restart the program, simply resume pedaling.

The program will continue until the display shows a time of 0:00. If you continue to pedal after the program is completed, the display will continue to show exercise feedback; however, the display will not show the elapsed time until you select the manual mode or a new program.

4. Follow your progress with the display.

See step 4 on page 12.

5. Measure your heart rate if desired.

See step 5 on page 12.

6. When you are finished exercising, the console will automatically turn off.

See step 6 on page 12.

HOW TO USE A HEART RATE PROGRAM

1. Turn on the console.

To turn on the console, press any button or begin pedaling. The display will light and the console will be ready for use.

2. Select a heart rate program.

To select one of the two heart rate programs, press the button with the heart rate symbol once or twice until P1 or P2 appears in the display. The first section of the display will show how long the program will last.

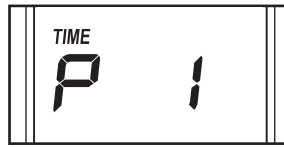

3. Enter a target heart rate setting.

If you select the first heart rate program, the maximum target heart rate setting of the program will appear in the display.

Use the Increase and Decrease buttons to change the maximum heart rate setting, if desired. Note: If you change the maximum target heart rate setting, the intensity level of the entire program will change.



If you select the second heart rate program, the target heart rate setting for the program will appear in the display. Use the Increase and Decrease buttons to change the target heart rate setting, if desired. Note: The same target heart rate setting will be used for the entire program.

4. Hold the handgrip pulse sensor.

It is not necessary to hold the handgrip pulse sensor continuously during a heart rate program; however, you should hold the handgrip pulse sensor frequently for the program to operate properly.

Each time you hold the handgrip pulse sensor, keep your hands on the metal contacts for at least 30 seconds.

5. Begin pedaling to start the program.

First heart rate control program—This program is divided into 30 one-minute segments. One target heart rate setting is programmed for each segment. Note: The same target heart rate setting may be programmed for two or more consecutive segments.

Second heart rate program—The same target heart rate is programmed for all segments of this program.

Both heart rate programs—As you pedal, the console will regularly compare your heart rate to the target heart rate setting. If your heart rate is too far below or above the target heart rate, the resistance of the pedals will automatically increase or decrease to bring your heart rate closer to the target heart rate.

You will also be prompted to pedal at a steady pace. When the word “faster” appears in the display, increase your pace.

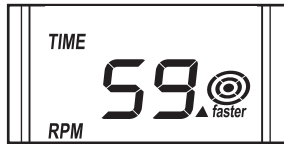

When the word “slower” appears, decrease your pace. When the center of the target flashes, maintain your current pace. **IMPORTANT: Make sure to pedal at a pace that is comfortable for you.**

If the resistance level for the current segment is too high or too low, you can manually override the level by pressing the decrease and increase buttons; however, if you change the resistance level, you might not maintain the target heart rate. Also, when the console compares your heart rate to the target heart rate setting, the resistance of the pedals may automatically increase or decrease to bring your heart rate closer to the target heart rate setting.

6. Follow your progress with the display.

See step 4 on page 12.

7. Measure your heart rate if desired.

See step 5 on page 12.

8. When you are finished exercising, the console will turn off automatically.

See step 6 on page 12.

HOW TO CONNECT YOUR CD PLAYER, VCR, OR COMPUTER

To use iFIT.com CDs, the elliptical exerciser must be connected to your portable CD player, portable stereo, home stereo, or computer with CD player. See pages 15 to 17 for connecting instructions. **To use iFIT.com videocassettes**, the elliptical exerciser must be connected to your VCR. See page 17 for connecting instructions. **To use iFIT.com programs directly from our website**, the elliptical exerciser must be connected to your computer. See page 17.

HOW TO CONNECT YOUR PORTABLE CD PLAYER

Note: If your CD player has separate LINE OUT and PHONES jacks, see instruction A below. If your CD player has only one jack, see instruction B.

- A. Plug one end of the audio cable into the jack beneath the console. Plug the other end of the audio cable into the LINE OUT jack on your CD player. Plug your headphones into the PHONES jack.

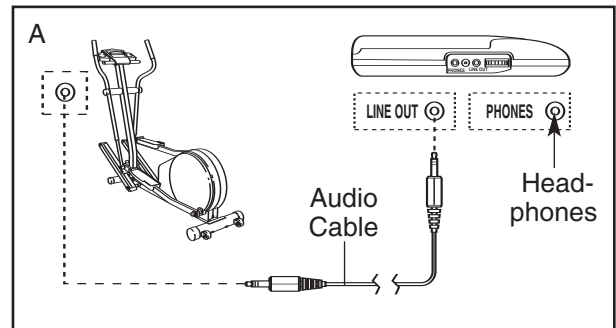

- B. Plug one end of the audio cable into the jack beneath the console. Plug the other end of the audio cable into the splitter. Plug the splitter into the PHONES jack on your CD player. Plug your headphones into the other side of the splitter.

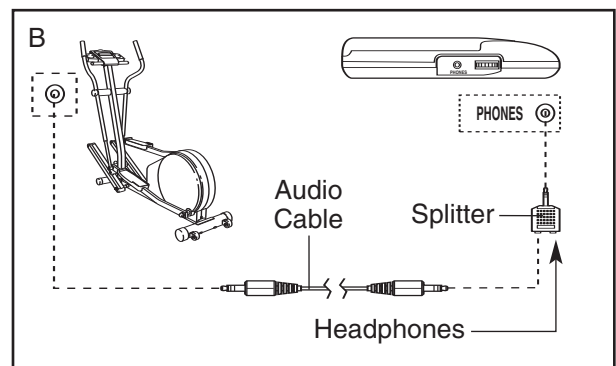

HOW TO CONNECT YOUR PORTABLE STEREO

Note: If your stereo has an RCA-type AUDIO OUT jack, see instruction A below. If your stereo has a 3.5mm LINE OUT jack, see instruction B. If your stereo has only a PHONES jack, see instruction C.

- A. Plug one end of the audio cable into the jack beneath the console. Plug the other end of the audio cable into the adaptor. Plug the adaptor into an AUDIO OUT jack on your stereo.

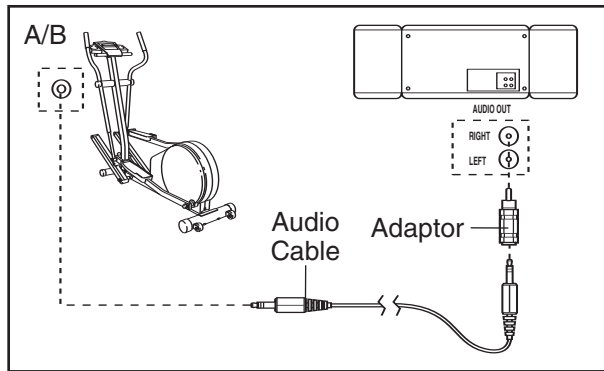

- B. See the drawing above. Plug one end of the audio cable into the jack beneath the console. Plug the other end of the audio cable into the LINE OUT jack on your stereo. Do not use the adaptor.
- C. Plug one end of the audio cable into the jack beneath the console. Plug the other end of the audio cable into the splitter. Plug the splitter into the PHONES jack on your stereo. Plug your headphones into the other side of the splitter.

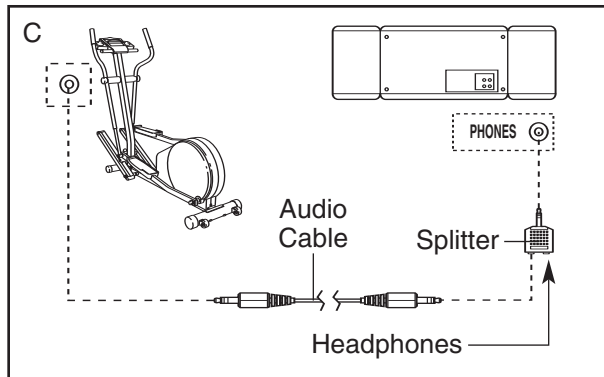

HOW TO CONNECT YOUR HOME STEREO

Note: If your stereo has an unused LINE OUT jack, see instruction A below. If the LINE OUT jack is being used, see instruction B.

- A. Plug one end of the audio cable into the jack beneath the console. Plug the other end of the audio cable into the adaptor. Plug the adaptor into the LINE OUT jack on your stereo.

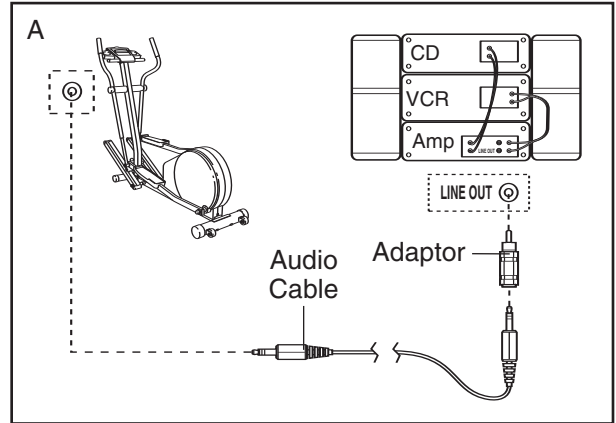

- B. Plug one end of the audio cable into the jack beneath the console. Plug the other end of the audio cable into the adaptor. Plug the adaptor into an RCA Y-adaptor (available at electronics stores). Next, remove the wire that is currently plugged into the LINE OUT jack on your stereo and plug the wire into the unused side of the Y-adaptor. Plug the Y-adaptor into the LINE OUT jack on your stereo.

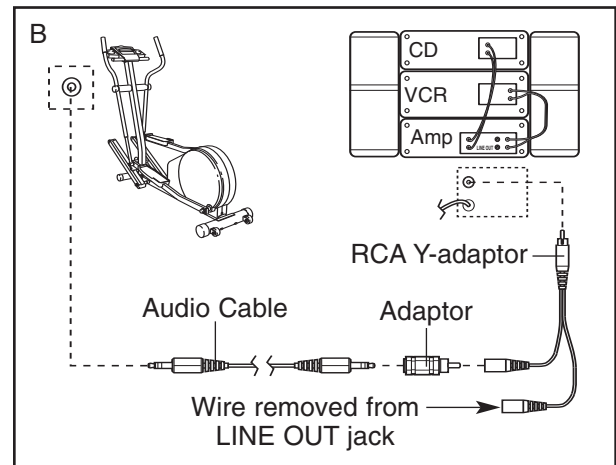

HOW TO CONNECT YOUR COMPUTER

Note: If your computer has a 3.5mm LINE OUT jack, see instruction A. If your computer has only a PHONES jack, see instruction B.

- A. Plug one end of the audio cable into the jack beneath the console. Plug the other end of the audio cable into the LINE OUT jack on your computer.

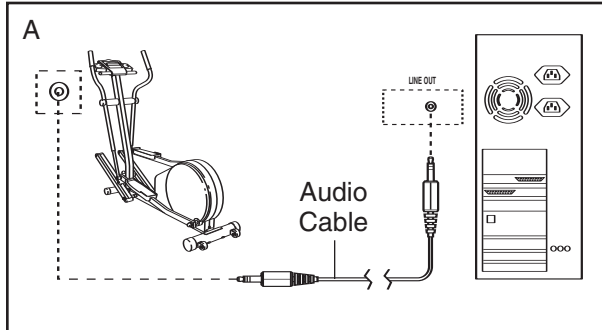

- B. Plug one end of the audio cable into the jack beneath the console. Plug the other end of the audio cable into the splitter. Plug the splitter into the PHONES jack on your computer. Plug your headphones or speakers into the other side of the splitter.

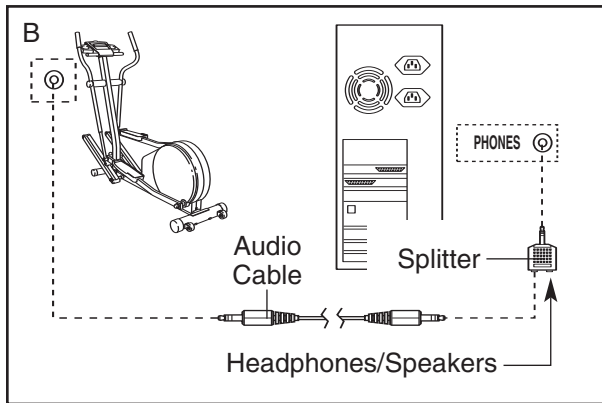

HOW TO CONNECT YOUR VCR

Note: If your VCR has an unused AUDIO OUT jack, see instruction A below. If the AUDIO OUT jack is being used, see instruction B. If you have a TV with a built-in VCR, see instruction B. If your VCR is connected to your home stereo, see HOW TO CONNECT YOUR HOME STEREO on page 16.

- A. Plug one end of the audio cable into the jack beneath the console. Plug the other end of the audio cable into the adaptor. Plug the adaptor into the AUDIO OUT jack on your VCR.

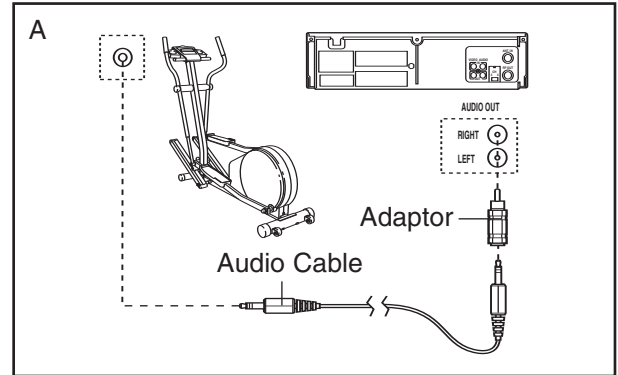

- B. Plug one end of the audio cable into the jack beneath the console. Plug the other end of the audio cable into the adaptor. Plug the adaptor into an RCA Y-adaptor (available at electronics stores). Next, remove the wire that is currently plugged into the AUDIO OUT jack on your VCR and plug the wire into the unused side of the Y-adaptor. Plug the Y-adaptor into the AUDIO OUT jack on your VCR.

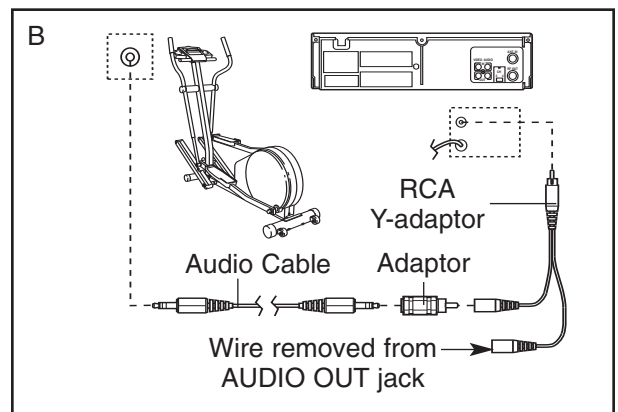

HOW TO USE AN iFIT.COM CD OR VIDEO PROGRAM

To use iFIT.com CDs or videocassettes, the elliptical exerciser must be connected to your portable CD player, portable stereo, home stereo, computer with CD player, or VCR. See HOW TO CONNECT YOUR CD PLAYER, VCR, OR COMPUTER on page 15. **To purchase iFIT.com CDs and videocassettes, visit our website at www.iFIT.com.**

Follow the steps below to use an iFIT.com CD or video program.

1. Turn on the console.

See step 1 on page 12.

2. Select the iFIT.com mode.

To select the iFIT.com mode, press the iFIT button.

3. Insert the iFIT.com CD or videocassette.

If you are using an iFIT.com CD, insert the CD into your CD player. If you are using an iFIT.com videocassette, insert the videocassette into your VCR.

4. Press the play button on your CD player or VCR.

A moment after you press the play button, your personal trainer will begin guiding you through your workout. Simply follow your personal trainer's instructions.

The program will function in almost the same way as a smart program (see step 3 on page 13). However, an electronic "chirping" sound will alert you when the resistance level and/or the target pace is about to change.

Note: If the resistance of the pedals and/or the target pace does not change when a "chirp" sounds:

- **Make sure that the indicator near the iFIT button is lit.**
- **Adjust the volume of your CD player or VCR. If the volume is too high or too low, the console may not detect the program signals.**
- **Make sure that the audio cable is properly connected and that it is fully plugged in.**

5. Follow your progress with the display.

See step 4 on page 12.

6. Measure your heart rate if desired.

See step 5 on page 12.

7. When you are finished exercising, the console will turn off automatically.

See step 6 on page 12.

HOW TO USE A PROGRAM DIRECTLY FROM OUR WEBSITE

Our website at www.iFIT.com allows you to play iFIT.com programs directly from the Internet. To use programs from our website, the elliptical exerciser must be connected to your home computer. See **HOW TO CONNECT YOUR COMPUTER** on page 17. In addition, you must have an Internet connection and an Internet service provider. A list of specific system requirements is found on our website.

Follow the steps below to use a program from our website.

1. Turn on the console.

See step 1 on page 12.

2. Select the iFIT.com mode.

To select the iFIT.com mode, press the iFIT button.

3. Go to your computer and start an Internet connection.

4. Start your Web browser, if necessary, and go to our website at www.iFIT.com.

5. Follow the desired links on our website to select a program.

6. Follow the online instructions to start the program.

When you start the program, an on-screen count-down will begin.

7. Return to the elliptical exerciser and begin pedaling.

When the on-screen countdown ends, the program will begin. The program will function in almost the same way as a smart program (see step 3 on page 13). However, an electronic “chirping” sound will alert you when the resistance level and/or the target pace is about to change.

8. Follow your progress with the display.

See step 4 on page 12.

9. Measure your heart rate if desired.

See step 5 on page 12.

10. When you are finished exercising, the console will turn off automatically.

See step 6 on page 12.

THE OPTIONAL CHEST PULSE SENSOR

The optional chest pulse sensor provides hands-free operation and continuously monitors your heart rate during your workouts. **To purchase the optional chest pulse sensor, call the telephone number on the front cover of this manual.**

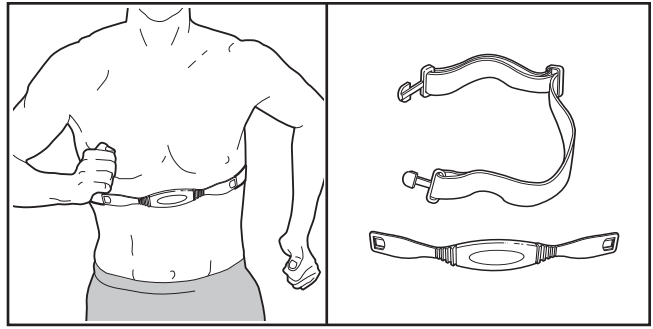

MAINTENANCE AND TROUBLESHOOTING

Inspect and tighten all parts of the elliptical exerciser regularly. Replace any worn parts immediately.

To clean the elliptical exerciser, use a damp cloth and a small amount of mild detergent. **IMPORTANT: Keep liquids away from the console and keep the console out of direct sunlight. During storage, remove the batteries from the console.**

BATTERY REPLACEMENT

If the console display becomes dim, the batteries should be replaced. See assembly step 4 on page 7.

HANDGRIP PULSE SENSOR TROUBLESHOOTING

- Avoid moving your hands while using the handgrip pulse sensor; excessive movement may interfere with heart rate readings. Do not hold the metal contacts too tightly.
- For the most accurate heart rate reading, hold the metal contacts for about 15 seconds.
- For optimal performance of the handgrip pulse sensor, clean the metal contacts with a soft cloth—do not use alcohol, abrasives, or chemicals.

HOW TO ADJUST THE REED SWITCH

If the console does not display correct feedback, the reed switch should be adjusted. To do this, you must remove the Pedal Springs (11), the right Pedal Disc (15), and the Side Shields (3, 4). See step 8 on page 9 and remove the Pedal Springs.

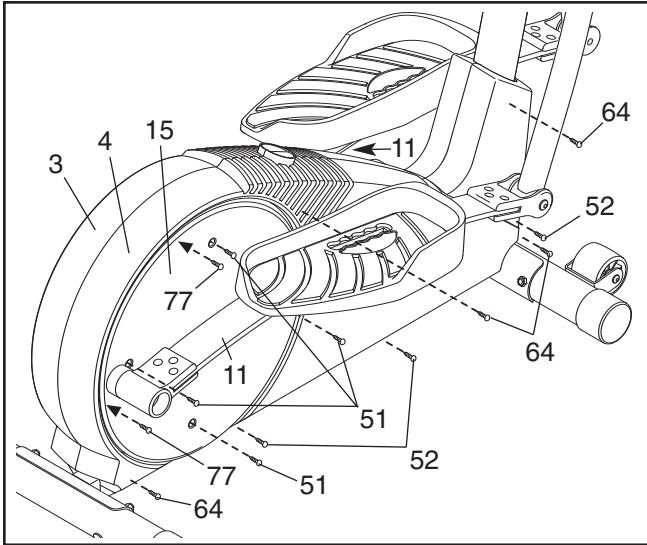

Next, remove the four Screws (51) from the right Pedal Disc (15), and slide the Pedal Disc off. Remove all Screws (52, 64) from the Right Side Shield (4) and the two Screws (77) from beneath the Pedal Disc, and then remove the Right Side Shield. Remove all Screws (52) from the Left Side Shield (3) and remove the Left Side Shield.

Next, see the drawing to the right and locate the Reed Switch (53). Loosen, but do not remove, the indicated M4 x 16mm Screw (52). Slide the Reed Switch slightly toward or away from the Magnet (58) on the fly-wheel, and then retighten the Screw. Turn the left Pedal Disc (15) for a moment. Repeat until the con-

sole displays correct feedback. When the Reed Switch is correctly adjusted, reattach the Side Shields (3, 4), the right Pedal Disc, and the Pedal Springs (11).

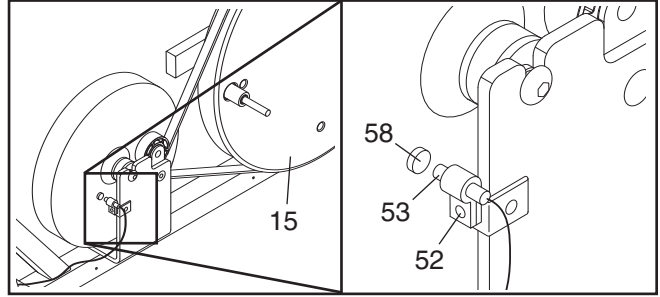

HOW TO ADJUST THE DRIVE BELT

If you can feel the pedals slip while you are pedaling, even when the resistance is adjusted to the highest level, the Drive Belt (19) may need to be adjusted.

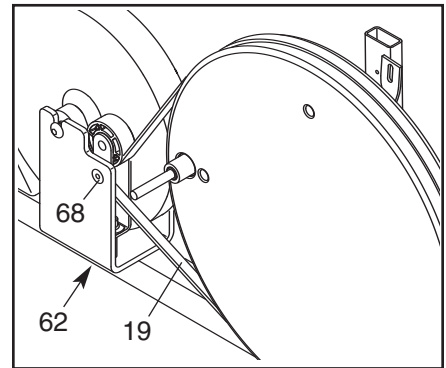

To adjust the Drive Belt, you must first remove both side shields. See HOW TO ADJUST THE REED SWITCH at the left and remove the side shields.

Next, loosen the M8 x 22mm Flat Head Bolt (68) and turn the M10 x 60mm Screw (62) until the Drive Belt (19) is tight. When the Drive Belt is tight, tighten the Flat Head Bolt. Reattach the side shields.

EXERCISE GUIDELINES

⚠ WARNING: Before beginning this or any exercise program, consult your physician. This is especially important for persons over the age of 35 or persons with pre-existing health problems.

The pulse sensor is not a medical device. Various factors may affect the accuracy of heart rate readings. The pulse sensor is intended only as an exercise aid in determining heart rate trends in general.

These guidelines will help you to plan your exercise program. For detailed exercise information, obtain a reputable book or consult your physician. Remember, proper nutrition and adequate rest are essential for successful results.

EXERCISE INTENSITY

Whether your goal is to burn fat or to strengthen your cardiovascular system, exercising at the proper intensity is the key to achieving results. You can use your heart rate as a guide to find the proper intensity level. The chart below shows recommended heart rates for fat burning and aerobic exercise.

165	155	145	140	130	125	115	♥
145	138	130	125	118	110	103	♥
125	120	115	110	105	95	90	♥
<hr/>							
20	30	40	50	60	70	80	

To find the proper intensity level, find your age at the bottom of the chart (ages are rounded off to the nearest ten years). The three numbers listed above your age define your “training zone.” The lowest number is the heart rate for fat burning, the middle number is the heart rate for maximum fat burning, and the highest number is the heart rate for aerobic exercise.

Burning Fat—To burn fat effectively, you must exercise at a low intensity level for a sustained period of time. During the first few minutes of exercise, your body uses *carbohydrate calories* for energy. Only after the first few minutes of exercise does your body begin to use stored *fat calories* for energy. If your goal is to burn fat, adjust the intensity of your exercise until your heart rate is near the lowest number in your training zone. For maximum fat burning, exercise with your heart rate near the middle number in your training zone.

Aerobic Exercise—If your goal is to strengthen your cardiovascular system, you must perform aerobic exercise, which is activity that requires large amounts of oxygen for prolonged periods of time. For aerobic exercise, adjust the intensity of your exercise until your heart rate is near the highest number in your training zone.

WORKOUT GUIDELINES

Warming up—Start with 5 to 10 minutes of stretching and light exercise. A warm-up increases your body temperature, heart rate, and circulation in preparation for exercise.

Training Zone Exercise—Exercise for 20 to 30 minutes with your heart rate in your training zone. (During the first few weeks of your exercise program, do not keep your heart rate in your training zone for longer than 20 minutes.) Breathe regularly and deeply as you exercise—never hold your breath.

Cooling down—Finish with 5 to 10 minutes of stretching. Stretching increases the flexibility of your muscles and helps to prevent post-exercise problems.

EXERCISE FREQUENCY

To maintain or improve your condition, complete three workouts each week, with at least one day of rest between workouts. After a few months of regular exercise, you may complete up to five workouts each week, if desired. Remember, the key to success is to make exercise a regular and enjoyable part of your everyday life.

SUGGESTED STRETCHES

The correct form for several basic stretches is shown at the right. Move slowly as you stretch—never bounce.

1. Toe Touch Stretch

Stand with your knees bent slightly and slowly bend forward from your hips. Allow your back and shoulders to relax as you reach down toward your toes as far as possible. Hold for 15 counts, then relax. Repeat 3 times. Stretches: Hamstrings, backs of knees, and back.

2. Hamstring Stretch

Sit with one leg extended. Bring the sole of the opposite foot toward you and rest it against the inner thigh of your extended leg. Reach toward your toes as far as possible. Hold for 15 counts, then relax. Repeat 3 times for each leg. Stretches: Hamstrings, lower back, and groin.

3. Calf/Achilles Stretch

With one leg in front of the other, reach forward and place your hands against a wall. Keep your back leg straight and your back foot flat on the floor. Bend your front leg, lean forward, and move your hips toward the wall. Hold for 15 counts, then relax. Repeat 3 times for each leg. To cause further stretching of the achilles tendons, bend your back leg as well. Stretches: Calves, achilles tendons, and ankles.

4. Quadriceps Stretch

With one hand against a wall for balance, reach back and grasp one foot with your other hand. Bring your heel as close to your buttocks as possible. Hold for 15 counts, then relax. Repeat 3 times for each leg. Stretches: Quadriceps and hip muscles.

5. Inner Thigh Stretch

Sit with the soles of your feet together and your knees outward. Pull your feet toward your groin as far as possible. Hold for 15 counts, then relax. Repeat 3 times. Stretches: Quadriceps and hip muscles.

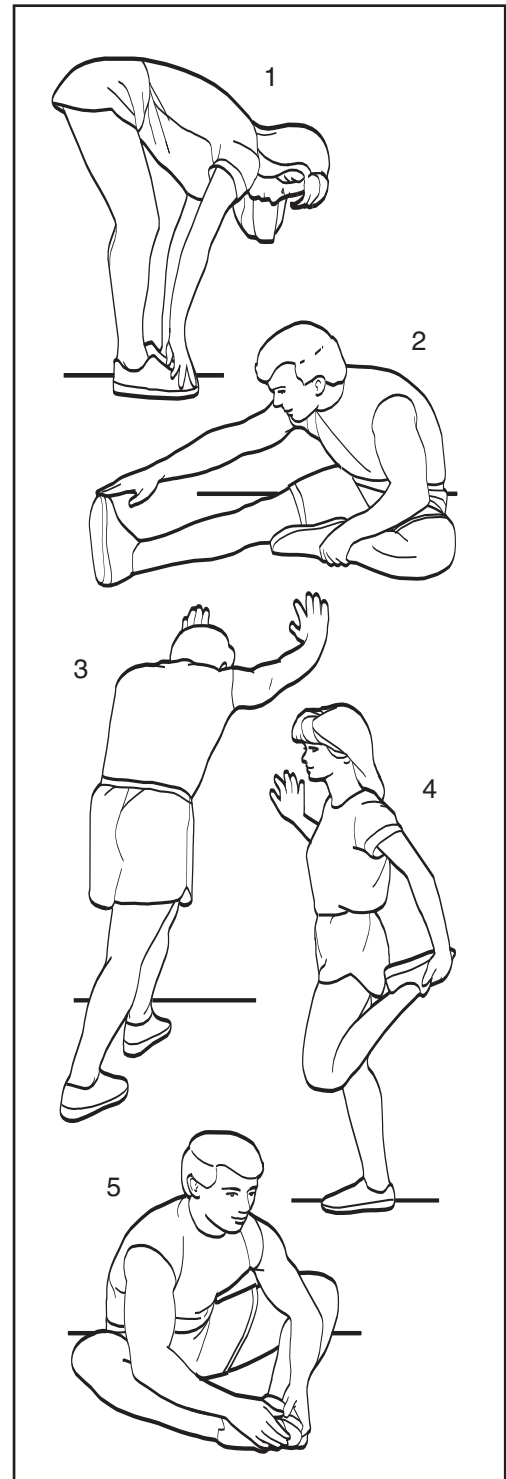

NOTES

NOTES

PART LIST—Model No. PFEVEL93407.0

R0907A

Key No.	Qty.	Description	Key No.	Qty.	Description
1	1	Frame	44	1	Extension Wire Harness
2	1	Upright	45	1	Resistance Control Motor
3	1	Left Side Shield	46	2	Handlebar Cap
4	1	Right Side Shield	47	2	Handlebar Spacer
5	2	Handlebar Leg	48	2	Upright Spacer
6	1	Left Handlebar	49	6	Small Handlebar Bushing
7	1	Pivot Axle	50	4	M8 x 45mm Button Bolt
8	1	Right Handlebar	51	8	M6 x 28mm Screw
9	1	Rear Stabilizer	52	11	M4 x 16mm Screw
10	1	Front Stabilizer	53	1	Reed Switch/Wire
11	2	Pedal Spring	54	1	Wire Clamp
12	1	Left Rear Spring Bracket	55	2	Handlebar Washer
13	1	Left Pedal	56	2	M8 x 25mm Patch Screw
14	1	Right Pedal	57	1	M10 Flat Head Bolt
15	2	Pedal Disc	58	1	Magnet
16	2	Disc Crossbar	59	7	M10 Split Washer
17	1	Flywheel	60	4	Large Handlebar Arm Bushing
18	1	Side Shield Bracket	61	2	5/16" x 25.4mm Hex Bolt
19	1	Drive Belt	62	1	M10 x 60mm Screw
20	2	Rear Endcap	63	2	Spring Spacer
21	2	Front Endcap	64	4	M4 x 25mm Screw
22	2	Wheel	65	1	Water Bottle Holder
23	1	Console	66	14	M6 Nylon Locknut
24	2	Handgrip	67	3	M10 x 25mm Button Screw
25	1	Idler	68	1	M8 x 22mm Flat Head Bolt
26	2	M4 x 19mm Screw	69	2	M5 Nylon Locknut
27	2	Handlebar Endcap	70	1	Right Rear Spring Bracket
28	2	M10 x 74mm Button Bolt	71	4	M5 x 16mm Self-tapping Screw
29	2	M3 x 16mm Screw	72	2	M5 x 16mm Screw
30	2	Large Snap Ring	73	1	Upright Extension
31	2	Large Bearing	74	2	M10 Bolt Set
32	1	Pedal Axle	75	12	M6 Washer
33	9	M10 Nylon Locknut	76	2	Front Spring Bracket
34	4	M10 x 75mm Carriage Bolt	77	2	M6 x 18mm Screw
35	2	Spring Bracket Washer	78	3	M10 Washer
36	12	M6 x 33.5mm Flat Head Bolt	79	1	Wire Harness
37	4	Pedal Arm Bushing	80	2	M10 x 30mm Carriage Bolt
38	5	M8 Nylon Locknut	81	2	Pedal Knob
39	1	Flywheel Washer	82	2	M5 x 14mm Self-tapping Screw
40	2	M10 x 27mm Patch Screw	83	2	23mm Wave Washer
41	2	M10 x 45mm Bolt	*	—	Hex Key
42	4	M5 Washer	*	—	Grease Packet
43	2	Wave Washer	*	—	User's Manual

Note: Specifications are subject to change without notice. See the back cover of this manual for information about ordering replacement parts. *These parts are not illustrated.

EXPLODED DRAWING—Model No. PFEVEL93407.0

R0907A

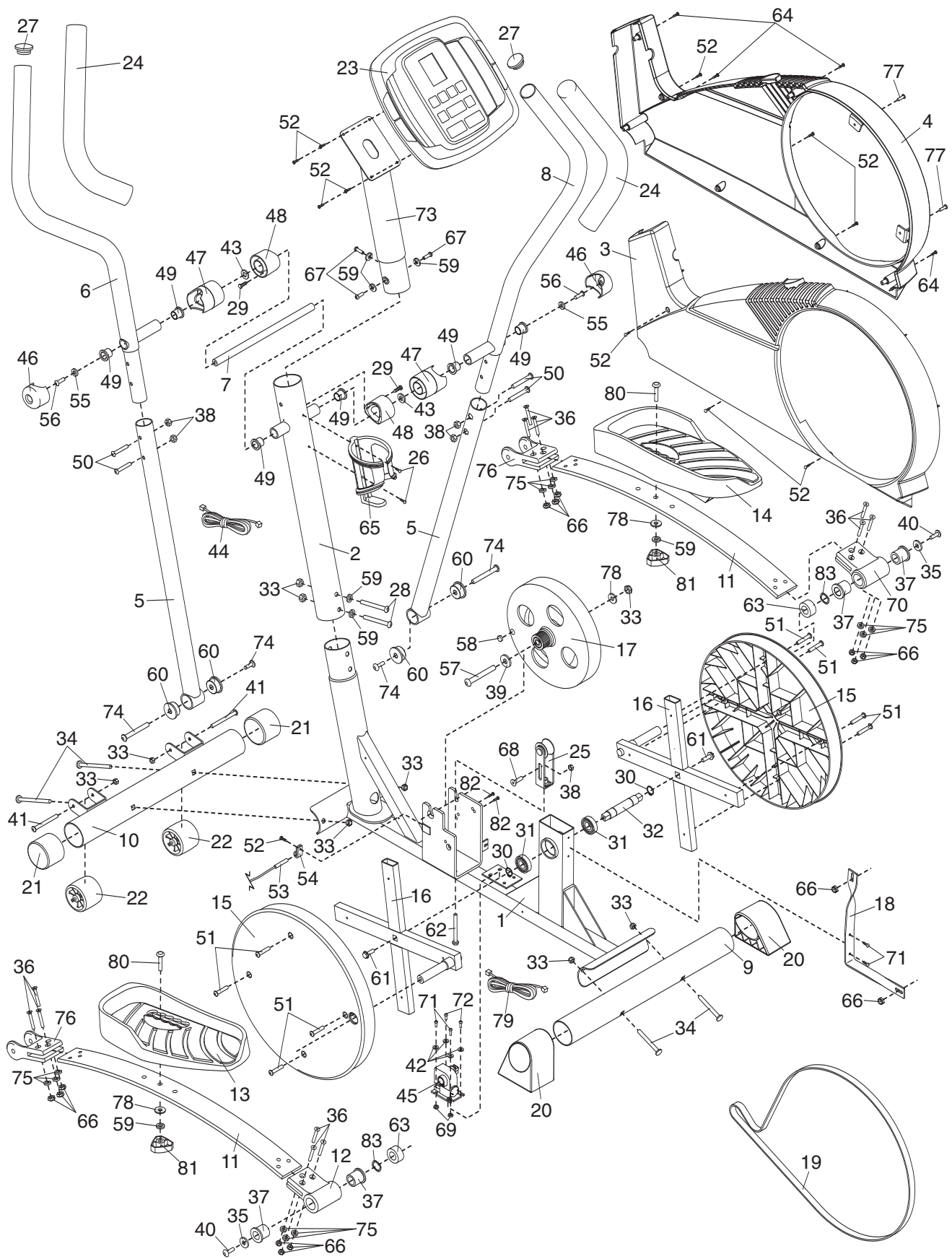

ORDERING REPLACEMENT PARTS

To order replacement parts, please see the front cover of this manual. To help us assist you, be prepared to provide the following information when contacting us:

- the model number and serial number of the product (see the front cover of this manual)
- the name of the product (see the front cover of this manual)
- the key number and description of the replacement part(s) (see the PART LIST and the EXPLODED DRAWING near the end of this manual)