

PRO-FORM[®]

500 ZLE

Model No. PFEVEL95910.1

Serial No. _____

Write the serial number in the space above for reference.

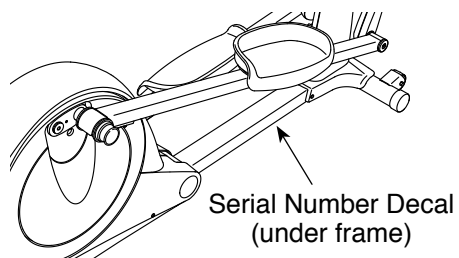

USER'S MANUAL

CUSTOMER SERVICE

UNITED KINGDOM

Call: 08457 089 009

From Ireland: 053 92 36102

Website: www.iconsupport.eu

E-mail: csuk@iconeurope.com

Write:

ICON Health & Fitness, Ltd.

c/o HI Group PLC

Express Way

CASTLEFORD

WF10 5QJ

UNITED KINGDOM

AUSTRALIA

Call: 1800 993 770

E-mail: australiacc@iconfitness.com

Write:

ICON Health & Fitness

PO Box 635

WINSTON HILLS NSW 2153

AUSTRALIA

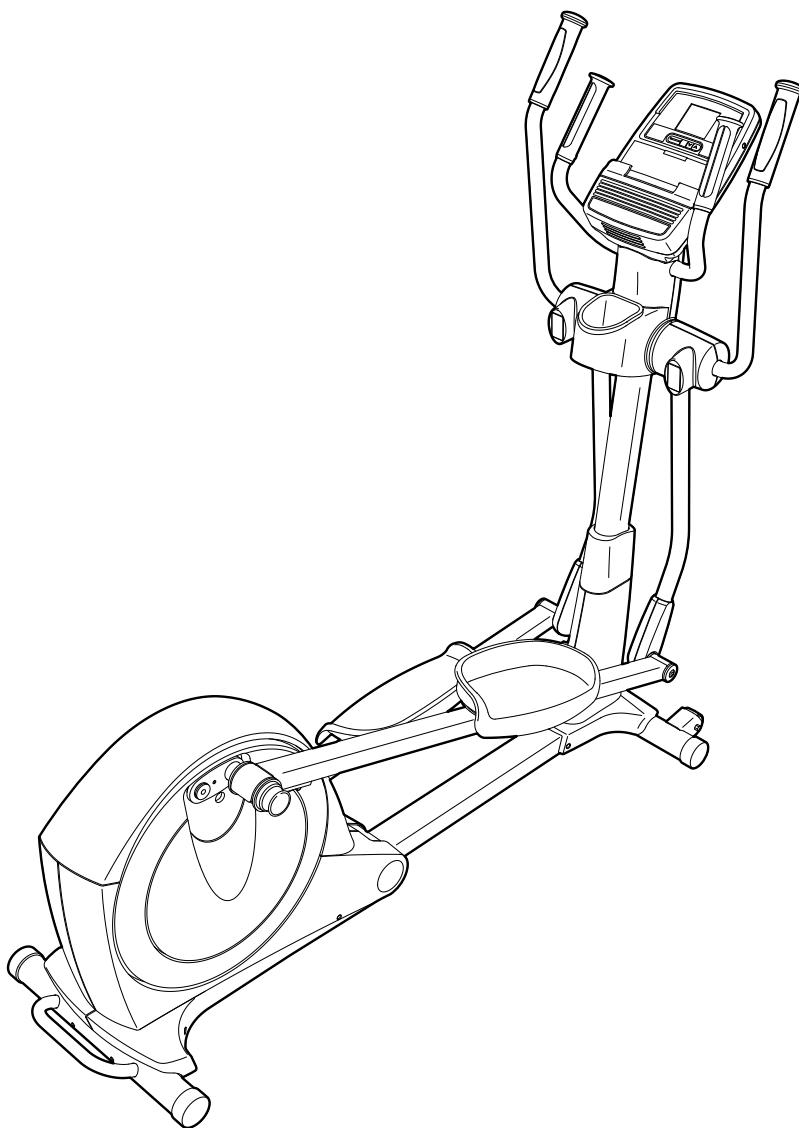

⚠ CAUTION

Read all precautions and instructions in this manual before using this equipment. Keep this manual for future reference.

TABLE OF CONTENTS

WARNING DECAL PLACEMENT	2
IMPORTANT PRECAUTIONS	3
BEFORE YOU BEGIN	4
PART IDENTIFICATION CHART	5
ASSEMBLY	6
HOW TO USE THE ELLIPTICAL	15
MAINTENANCE AND TROUBLESHOOTING	24
EXERCISE GUIDELINES	26
PART LIST	28
EXPLODED DRAWING	30
ORDERING REPLACEMENT PARTS	Back Cover
RECYCLING INFORMATION	Back Cover

WARNING DECAL PLACEMENT

This drawing shows the location(s) of the warning decal(s). **If a decal is missing or illegible, see the front cover of this manual and request a free replacement decal. Apply the decal in the location shown.** Note: The decal(s) may not be shown at actual size.

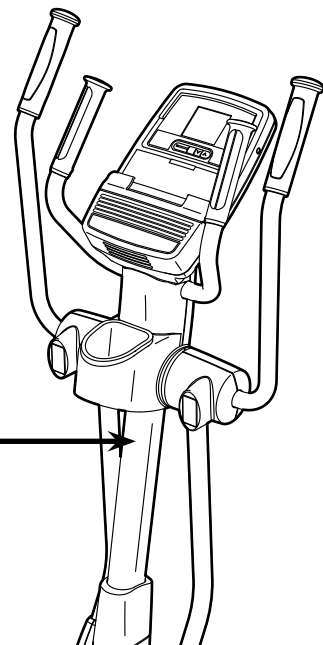
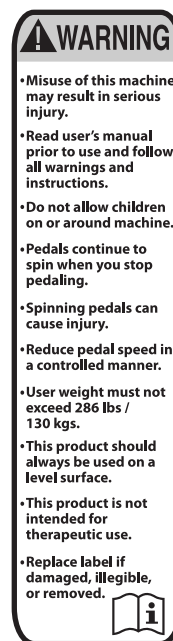

IMPORTANT PRECAUTIONS

⚠ WARNING: To reduce the risk of serious injury, read all important precautions and instructions in this manual and all warnings on your elliptical before using your elliptical. ICON assumes no responsibility for personal injury or property damage sustained by or through the use of this product.

1. It is the responsibility of the owner to ensure that all users of the elliptical are adequately informed of all precautions.
2. Before beginning any exercise program, consult your physician. This is especially important for persons over age 35 or persons with pre-existing health problems.
3. Use the elliptical only as described in this manual.
4. The elliptical is intended for home use only. Do not use the elliptical in a commercial, rental, or institutional setting.
5. Keep the elliptical indoors, away from moisture and dust. Do not put the elliptical in a garage or covered patio, or near water.
6. Place the elliptical on a level surface, with at least 3 ft. (0.9 m) of clearance in the front and rear of the elliptical and 2 ft. (0.6 m) on each side. To protect the floor or carpet from damage, place a mat under the elliptical.
7. Inspect and properly tighten all parts regularly. Replace any worn parts immediately.
8. Keep children under age 12 and pets away from the elliptical at all times.
9. The elliptical should not be used by persons weighing more than 286 lbs. (130 kg).
10. Wear appropriate clothes while exercising; do not wear loose clothes that could become caught on the elliptical. Always wear athletic shoes for foot protection while exercising.
11. Hold the handlebars or the upper body arms when mounting, dismounting, or using the elliptical.
12. The heart rate monitor is not a medical device. Various factors may affect the accuracy of heart rate readings. The heart rate monitor is intended only as an exercise aid in determining heart rate trends in general.
13. The elliptical does not have a freewheel; the pedals will continue to move until the flywheel stops. Reduce your pedaling speed in a controlled way.
14. Keep your back straight while using the elliptical; do not arch your back.
15. Over exercising may result in serious injury or death. If you feel faint or if you experience pain while exercising, stop immediately and cool down.

BEFORE YOU BEGIN

Thank you for selecting the revolutionary PROFORM® 500 ZLE elliptical. The 500 ZLE elliptical provides an impressive selection of features designed to make your workouts at home more effective and enjoyable.

For your benefit, read this manual carefully before you use the elliptical. If you have questions after reading this manual, please see the front cover of this

manual. To help us assist you, note the product model number and serial number before contacting us. The model number and the location of the serial number decal are shown on the front cover of this manual.

Before reading further, please familiarize yourself with the parts that are labeled in the drawing below.

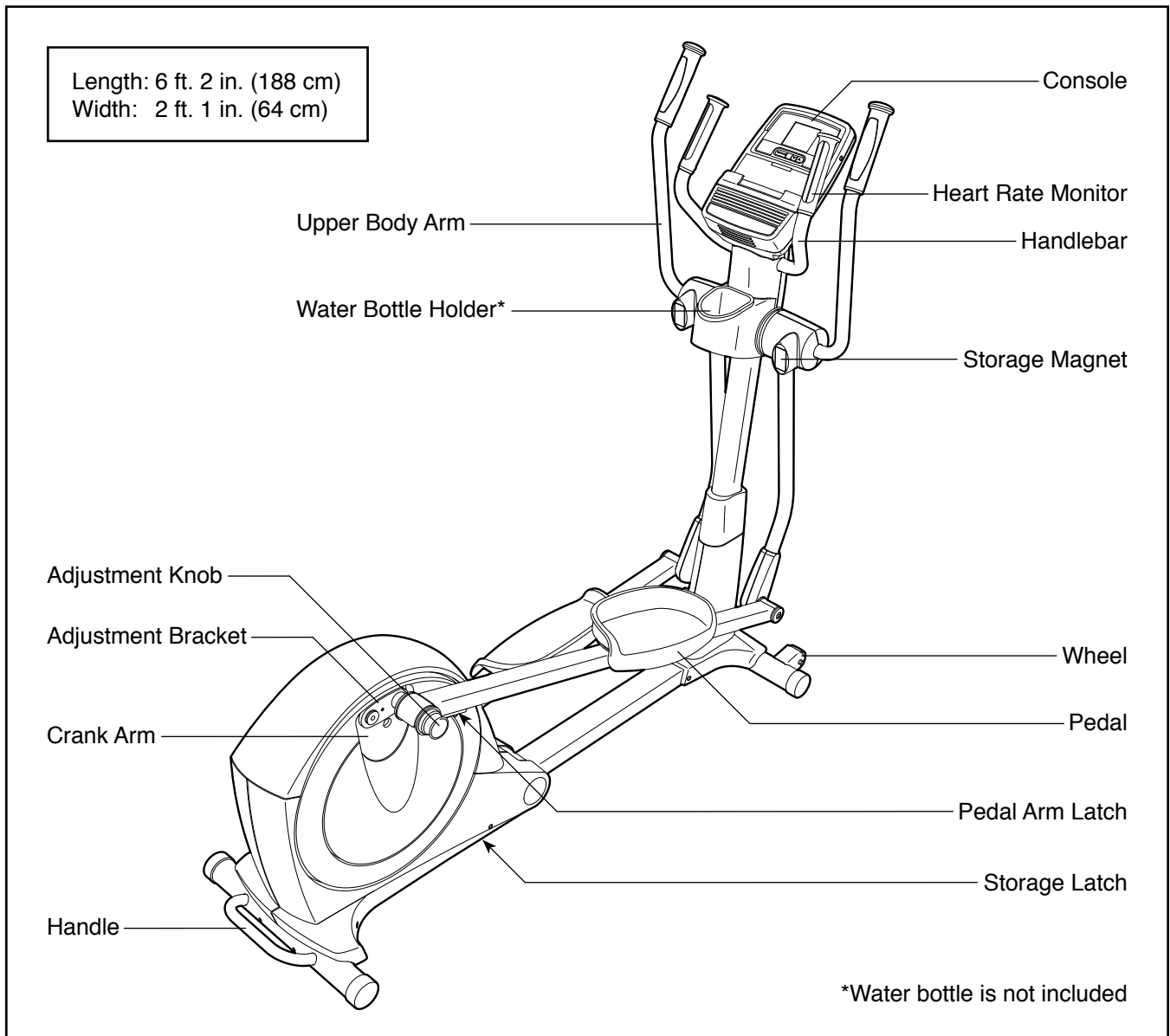

PART IDENTIFICATION CHART

Use the drawings below to identify the small parts needed for assembly. The number in parentheses below each drawing is the key number of the part, from the PART LIST near the end of this manual. The number following the key number is the quantity needed for assembly. **Note: If a part is not in the hardware kit, check to see if it has been preassembled. Extra parts may be included.**

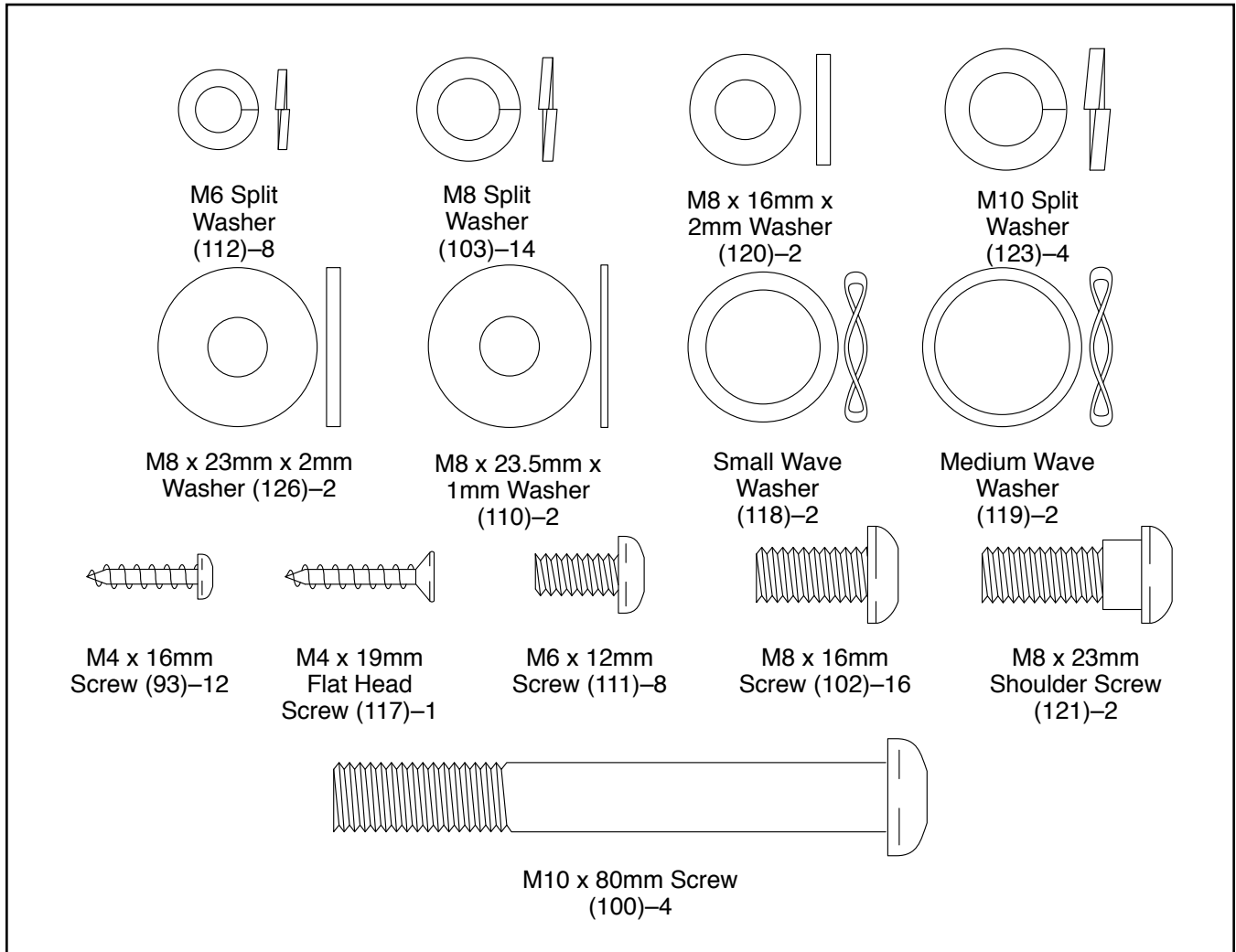

ASSEMBLY

- Assembly requires two persons.
- Place all parts in a cleared area and remove the packing materials. Do not dispose of the packing materials until you finish all assembly steps.
- Left parts are marked “L” or “Left” and right parts are marked “R” or “Right.”
- To identify small parts, see page 5.

- In addition to the included tool(s), assembly requires the following tool(s):

one Phillips screwdriver

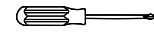

one rubber mallet

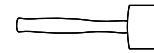

Assembly may be easier if you have a set of wrenches. To avoid damaging parts, do not use power tools.

1. Go to www.iconsupport.eu on your computer and register your product.

- activates your warranty
- saves you time if you ever need to contact Customer Service
- allows us to notify you of upgrades and offers

Note: If you do not have Internet access, call Customer Service (see the front cover of this manual) and register your product.

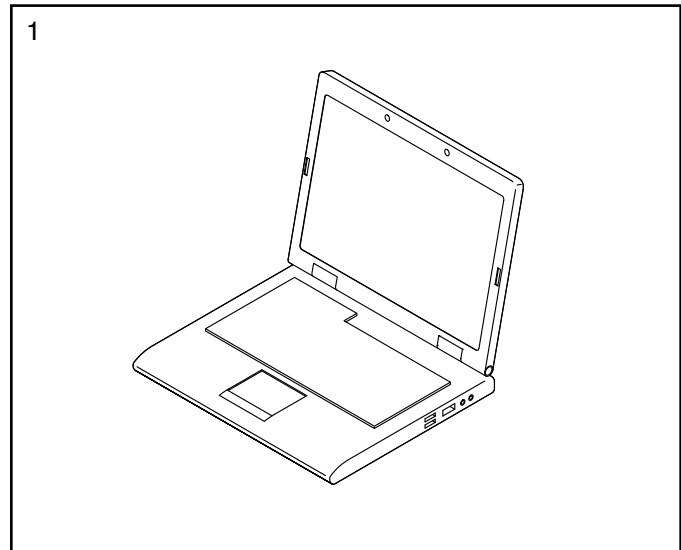

2. Identify the Front Stabilizer (3), and orient it as shown.

While another person lifts the Frame (1), attach the Front Stabilizer (3) to the Frame with two M10 x 80mm Screws (100) and two M10 Split Washers (123).

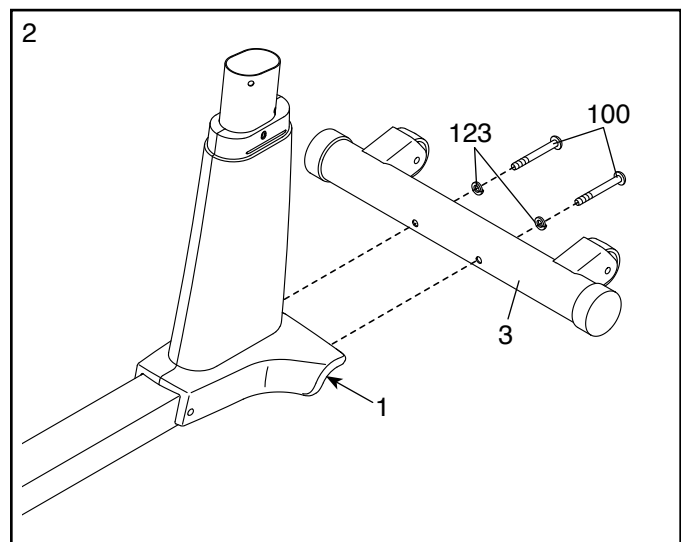

3. Identify the Rear Stabilizer (4), and orient it as shown.

While another person lifts the Folding Frame (2), attach the Rear Stabilizer (4) to the Folding Frame with two M10 x 80mm Screws (100) and two M10 Split Washers (123).

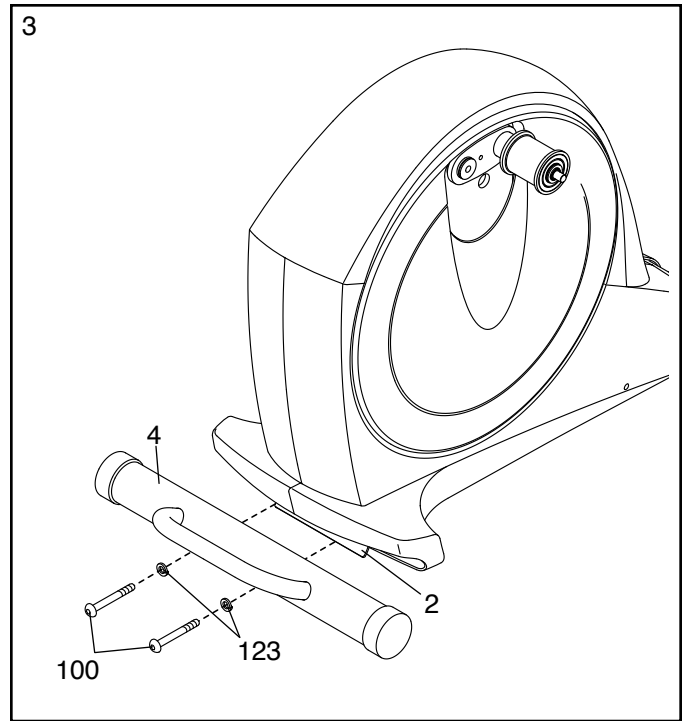

4. Orient the Upright (5) and the Top Cover (23) as shown. Slide the Top Cover upward onto the Upright.

Have a second person hold the Upright (5) and the Top Cover (23) near the Frame (1).

See the inset drawing. Find the wire tie in the Upright (5). Tie the lower end of the wire tie to the Wire Harness (60). Next, pull the upper end of the wire tie until the Wire Harness is routed through the Upright. Then, discard the wire tie.

Tip: To prevent the Wire Harness (60) from falling into the Upright (5), secure the Wire Harness with a rubber band or tape.

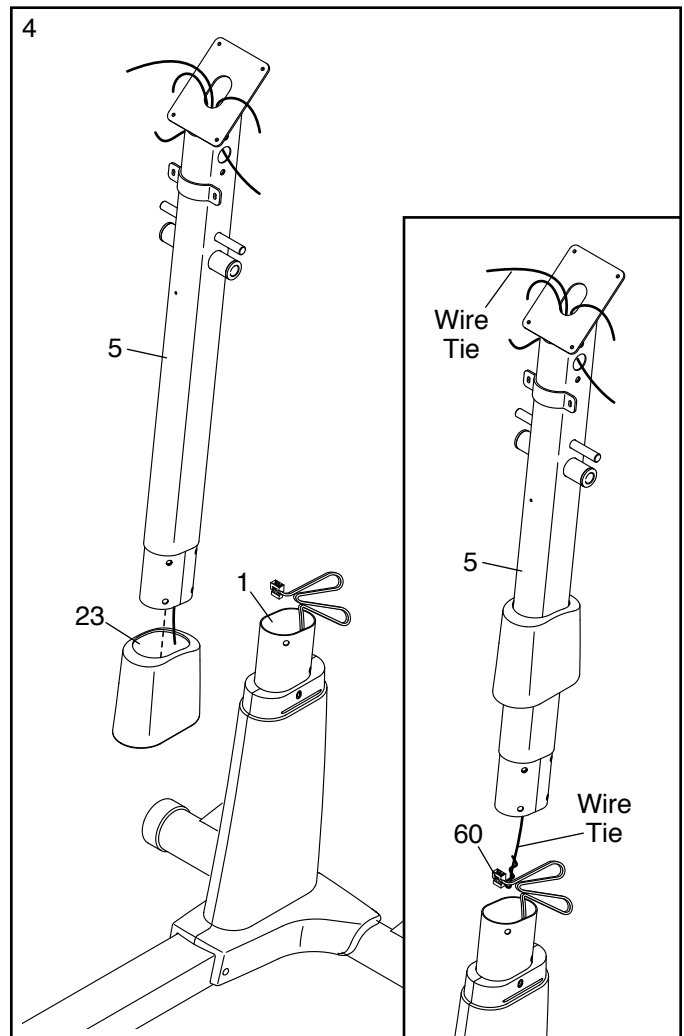

5. **Tip: Avoid pinching the Wire Harness (60).**
Insert the Upright (5) into the Frame (1).

Attach the Upright (5) with four M8 x 16mm Screws (102) and four M8 Split Washers (103).
Do not tighten the Screws yet.

Slide the Top Cover (23) downward. **Do not press the Top Cover over the Frame (1) yet.**

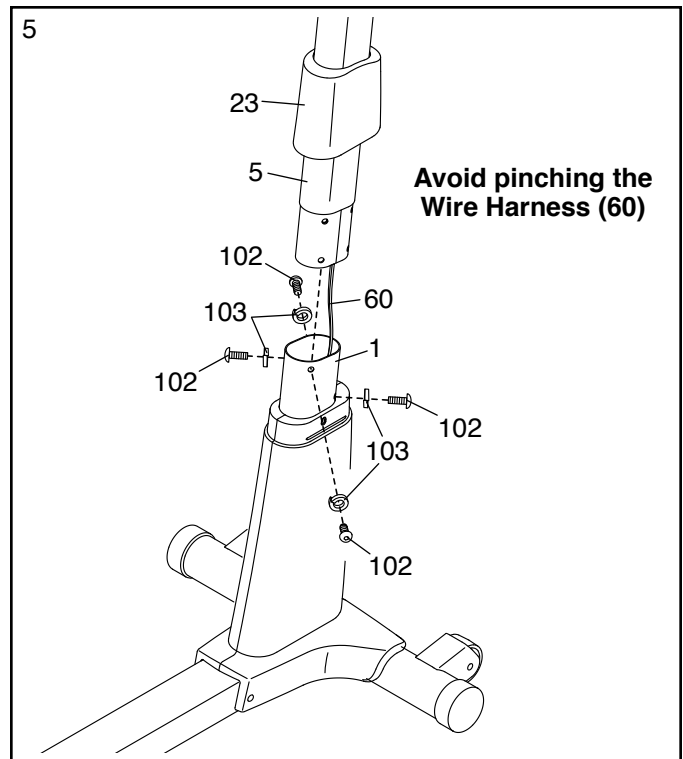

6. Apply a generous amount of the included grease to the Upright Axle (48) and to two Small Wave Washers (118).

Insert the Upright Axle (48) into the Upright (5) and center it. Slide a Small Wave Washer (118) onto each end of the Upright Axle.

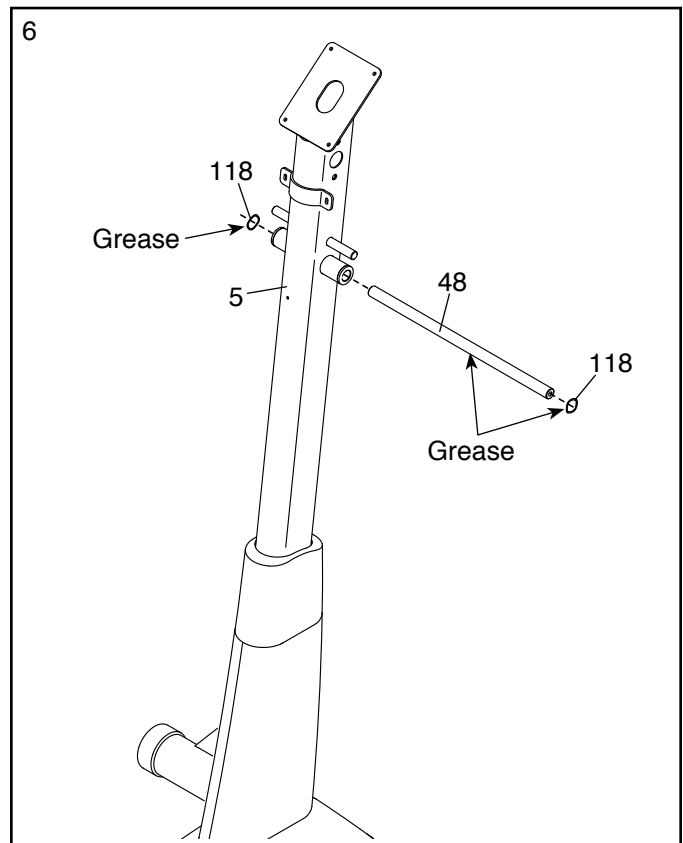

7. Identify the Right and Left Upper Body Legs (6, 7) and orient them as shown.

Slide the Right and Left Upper Body Legs (6, 7) onto the Upright Axle (48).

Tighten two M8 x 16mm Screws (102) with M8 x 23mm x 2mm Washers (126) into the Upright Axle (48) at the same time. **Firmly tighten the Screws.**

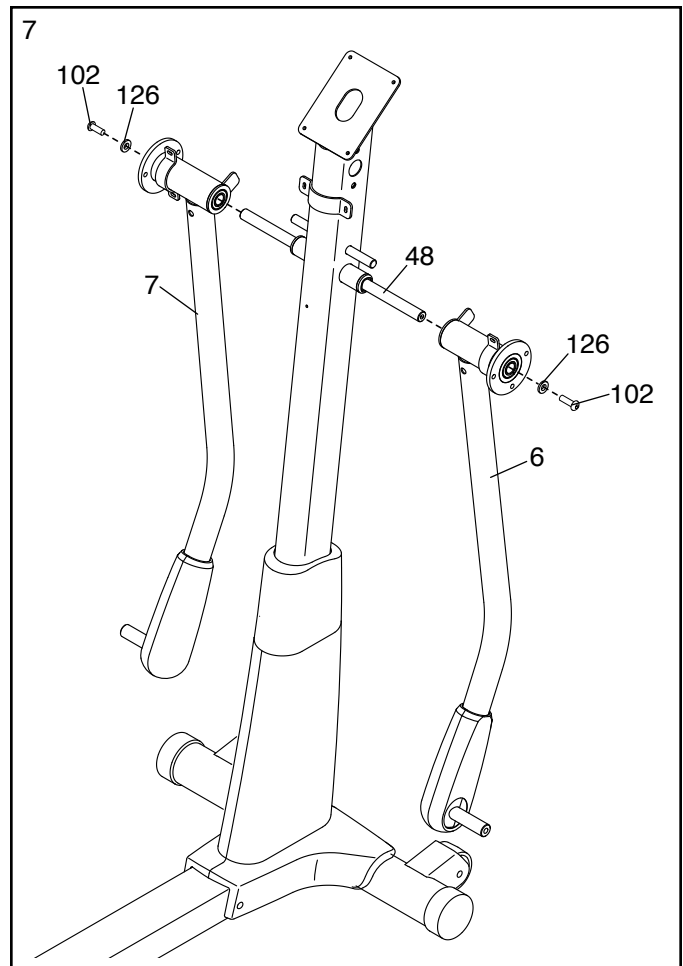

8. Apply grease to the axle on the Right Upper Body Leg (6) and to a Medium Wave Washer (119).

Orient a Leg Spacer (55) so that the flat side is facing away from the elliptical. Slide the Leg Spacer and the Medium Wave Washer (119) onto the Right Upper Body Leg (6).

Identify the Right Pedal Arm (12) and orient it as shown. Slide the Right Pedal Arm onto the Right Upper Body Leg (6).

Attach the Right Pedal Arm (12) with an M8 x 23mm Shoulder Screw (121), an M8 x 16mm x 2mm Washer (120), an Axle Cover (56), and an M8 x 23.5mm x 1mm Washer (110).

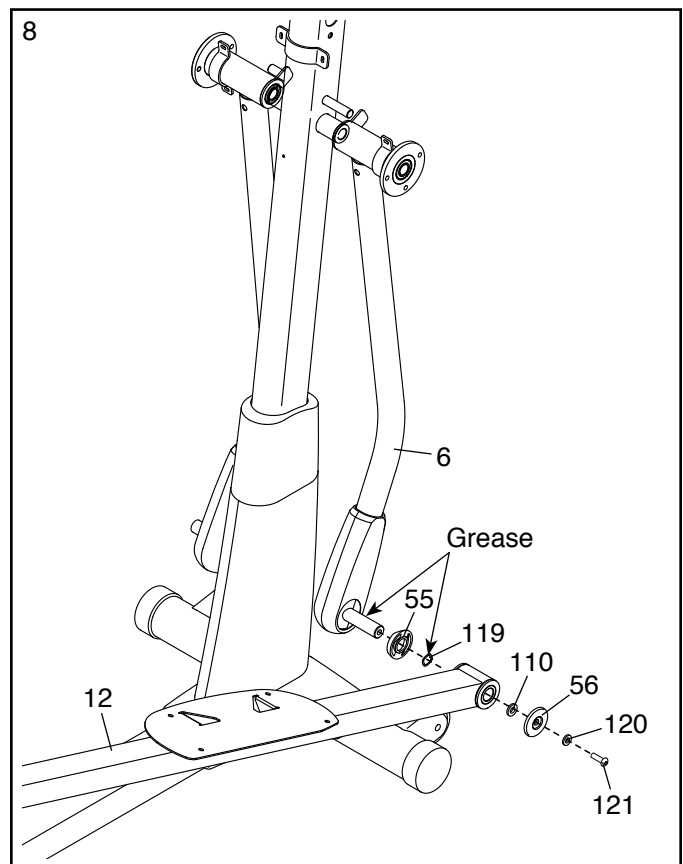

9. Press the Right Pedal Arm (12) onto the right Adjustment Sleeve (46). **Make sure that the Right Pedal Arm latches into place.**

Tighten an Adjustment Knob (45) onto the right Adjustment Pin (44).

Repeat step 8 and this step on the other side of the elliptical.

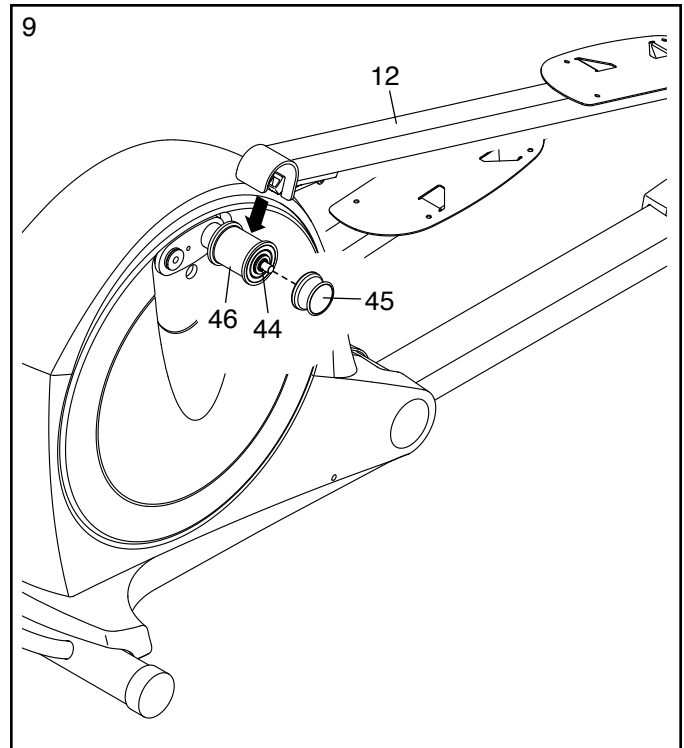

10. Identify the Right Pedal (14) and orient it as shown.

Attach the Right Pedal (14) to the Right Pedal Arm (12) with four M6 x 12mm Screws (111) and four M6 Split Washers (112).

Attach the Left Pedal (15) to the Left Pedal Arm (13) in the same way.

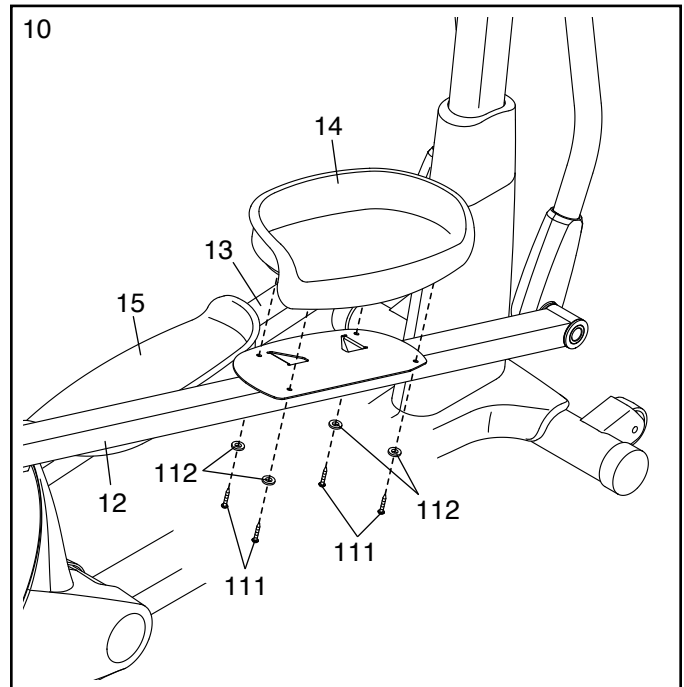

11. Identify the Right Upper Body Arm (8) and orient it as shown.

Attach the Right Upper Body Arm (8) to the Right Upper Body Leg (6) with three M8 x 16mm Screws (102) and three M8 Split Washers (103).

Attach the Left Upper Body Arm (9) to the Left Upper Body Leg (7) in the same way.

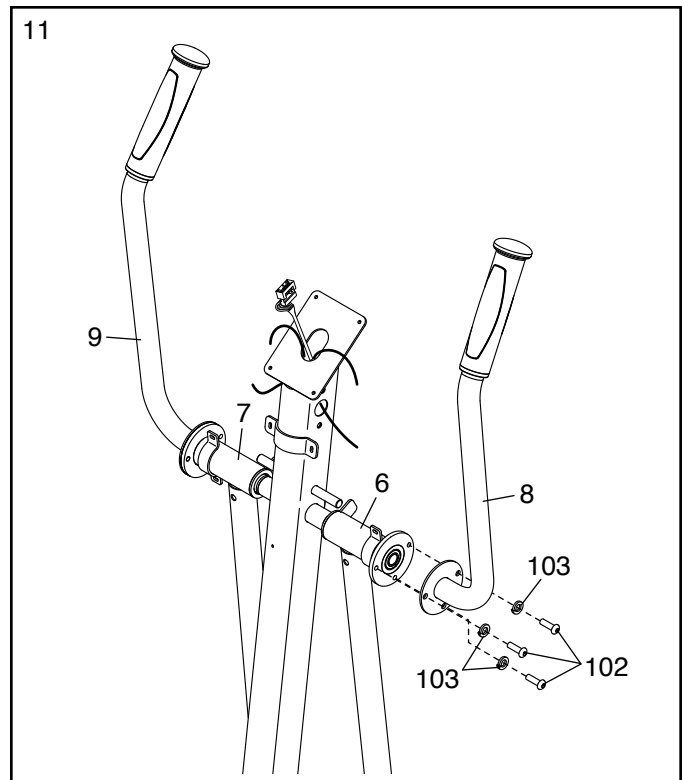

12. Identify the Right Handlebar (10) and orient it as shown.

Have a second person hold the Right Handlebar (10) near the right side of the Upright (5).

Locate the indicated wire tie in the Upright (5). Tie the lower end of the wire tie to the Pulse Wire (34) inside the Right Handlebar (10). Next, pull the upper end of the wire tie upward out of the top of the Upright. Then, untie and discard the wire tie.

Tip: Avoid pinching the Pulse Wire (34).
Attach the Right Handlebar (10) to the Upright (5) with two M8 x 16mm Screws (102) and two M8 Split Washers (103).

Attach the Left Handlebar (11) in the same way.

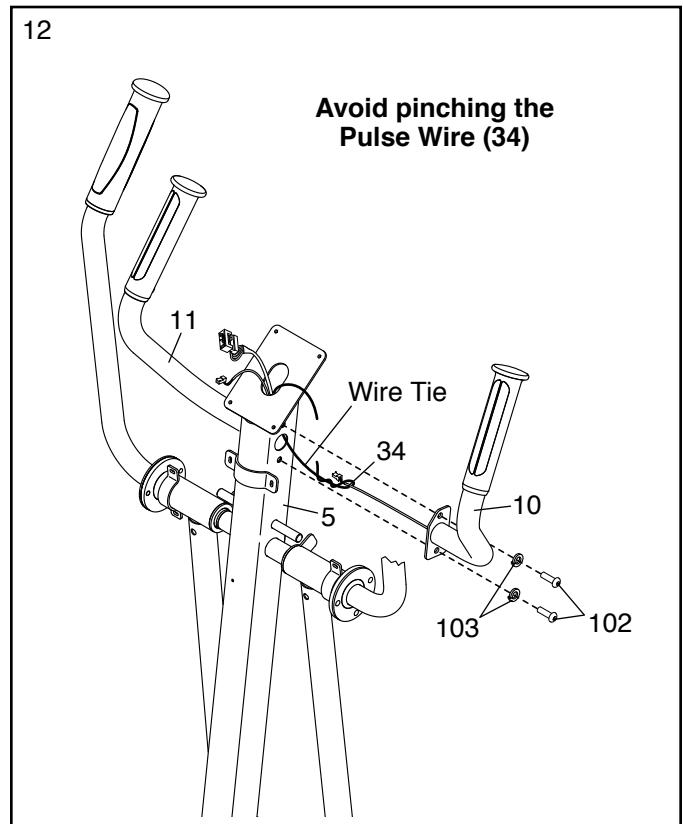

13. The Console (33) can use four D batteries (not included); alkaline batteries are recommended. Do not use old and new batteries together or alkaline, standard, and rechargeable batteries together. **IMPORTANT: If the Console has been exposed to cold temperatures, allow it to warm to room temperature before you insert batteries. Otherwise, you may damage the console displays or other electronic components.** Remove the screw and the battery cover, and insert batteries into the battery compartment. **Make sure to orient the batteries as shown by the diagram inside the battery compartment.** Then, reattach the battery cover.

To purchase an optional power adapter, call the telephone number on the cover of this manual. To avoid damaging the console, use only a manufacturer-supplied regulated power adapter. Remove the battery cover, remove the batteries, and plug one end of the power adapter into the receptacle inside the battery compartment. Plug the other end into an outlet that is installed in accordance with all local codes and ordinances. Route the wire on the power adapter through the slot in the battery cover, and reattach the battery cover.

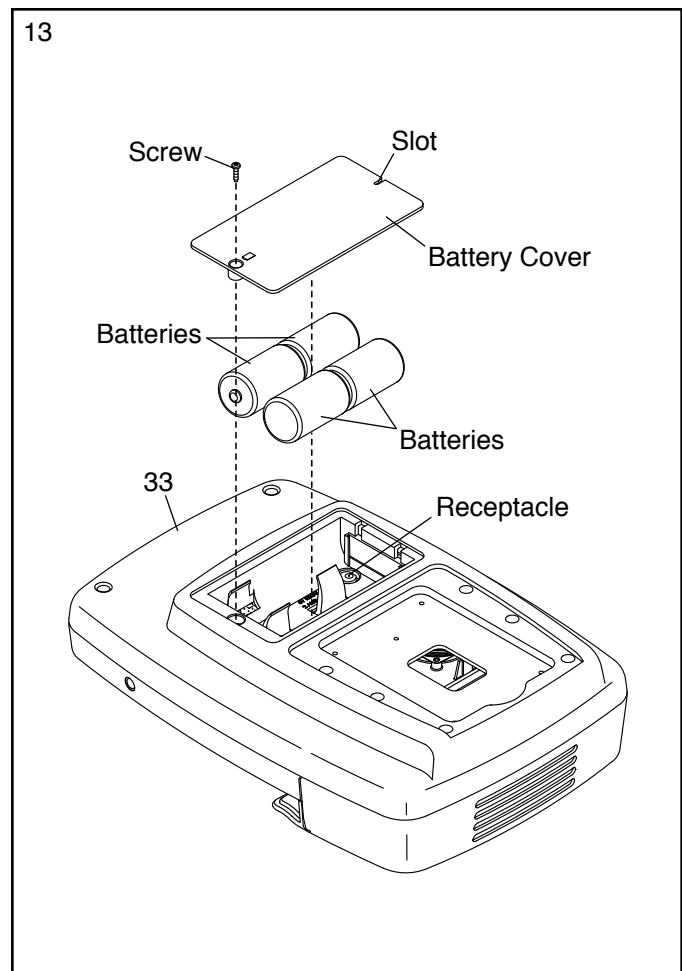

14. While a second person holds the Console (33) near the Upright (5), connect the console wires to the Wire Harness (60) and to the Pulse Wires (34).

Insert the excess wire into the Console (33).

Tip: Avoid pinching the wires. Attach the Console (33) to the Upright (5) with four M4 x 16mm Screws (93).

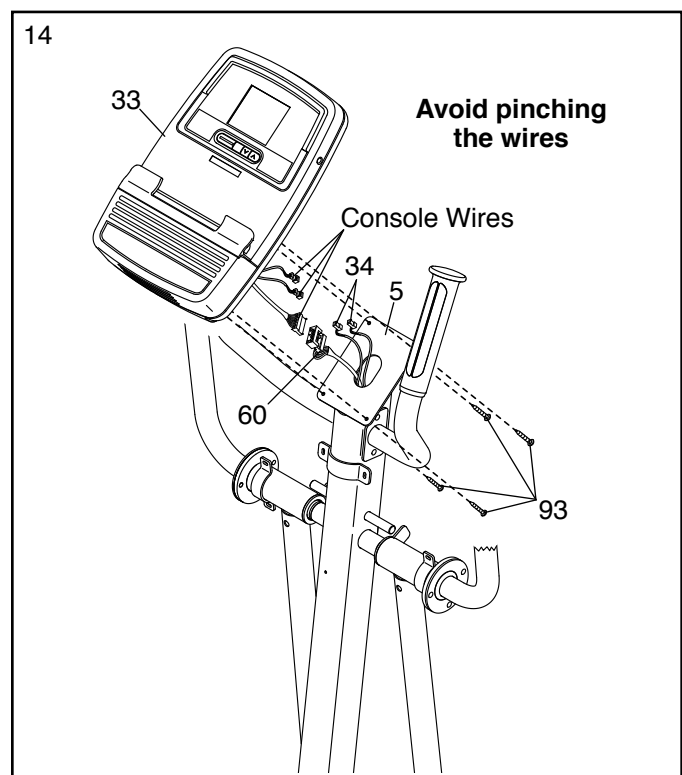

15. Attach the Rear Upright Cover (24) to the Upright (5) with two M4 x 16mm Screws (93) and an M4 x 19mm Flat Head Screw (117).

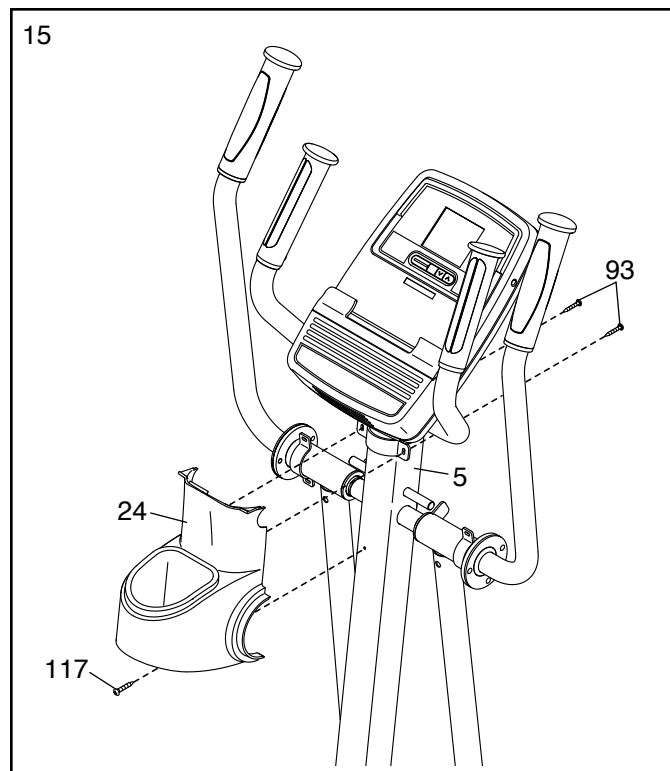

16. Attach the Front Upright Cover (25) around the Upright (5) by pressing the tabs on the Front Upright Cover into the Rear Upright Cover (24).

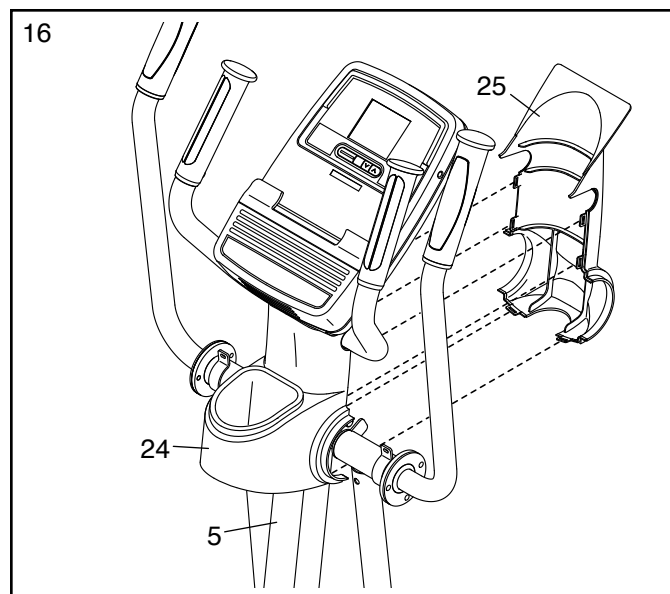

17. Identify the Right Rear and Front Leg Covers (29, 30).

Attach the Right Rear Leg Cover (29) to the Right Upper Body Leg (6) with three M4 x 16mm Screws (93).

Attach the Right Front Leg Cover (30) around the Right Upper Body Leg (6) by pressing the tabs on the Right Front Leg Cover into the Right Rear Leg Cover (29).

Attach the Left Rear and Front Leg Covers (31, 32) in the same way.

See step 5. Tighten the four M8 x 16mm Screws (102).

Then, slide the Top Cover (23) downward and press it over the Frame (1).

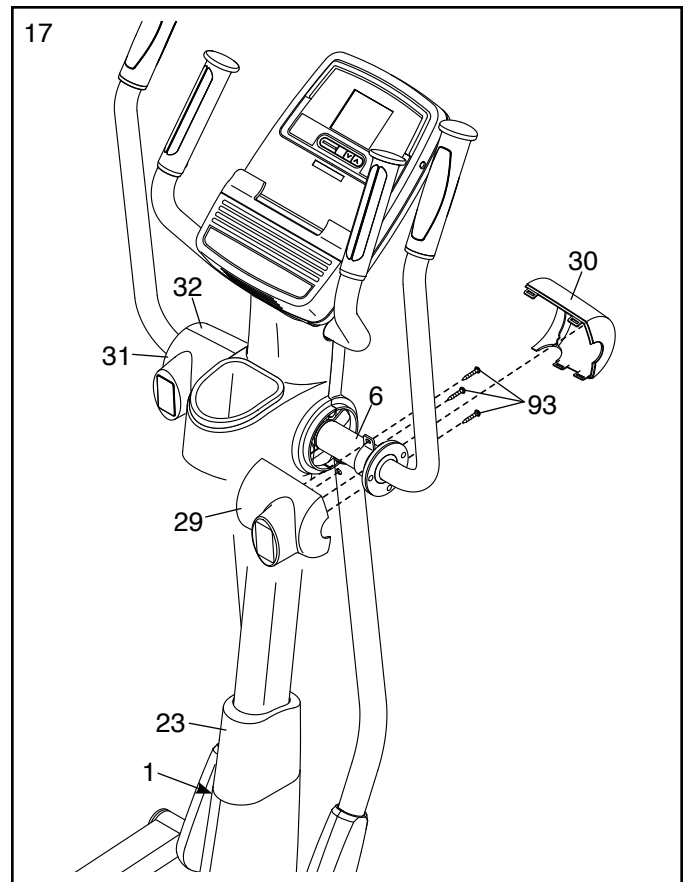

18. **Make sure that all parts of the elliptical are properly tightened.** Note: Extra parts may be included. To protect the floor or carpet from damage, place a mat under the elliptical.

HOW TO USE THE ELLIPTICAL

HOW TO FOLD AND UNFOLD THE ELLIPTICAL

When the elliptical is not in use, the frame can be folded out of the way. First, lift the latch under each pedal arm, and lift the pedal arms off the adjustment sleeves on the crank arms.

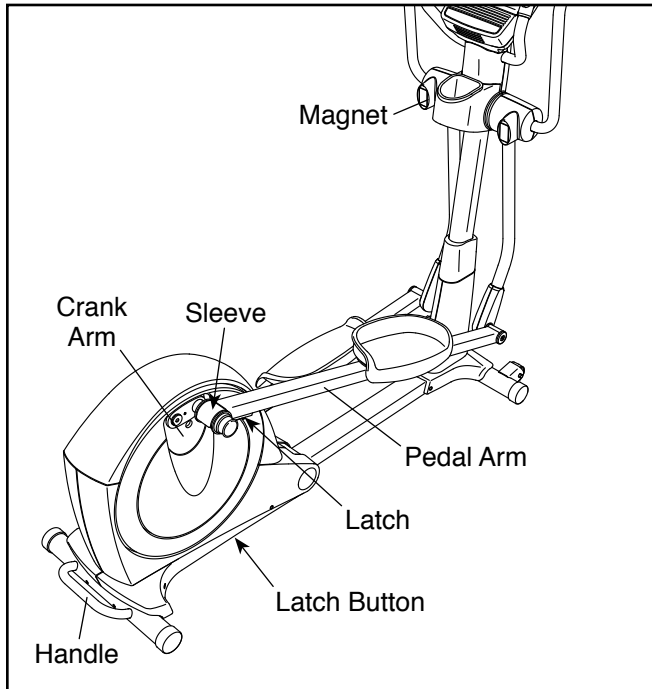

Next, raise the pedal arms until they touch the magnets on the upper body legs; the magnets will hold the pedal arms in place. Then, hold the handle and lift the frame until it locks in a vertical position.

To use the elliptical, first hold the handle, press the latch button, and lower the frame.

Next, pull the pedal arms off the magnets on the upper body legs. Then, **lift the latches under the pedal arms**, and set the pedal arms on the adjustment sleeves on the crank arms. Release the latches, and make sure that the pedal arms are securely connected to the adjustment sleeves.

HOW TO MOVE THE ELLIPTICAL

To move the elliptical, first fold it as described at the left. Next, stand in front of the elliptical, hold the upright, and place one foot against one of the wheels. Pull the upright until the elliptical rolls on the front wheels. Carefully move the elliptical to the desired position, and then lower it.

HOW TO ADJUST THE STRIDE LENGTH OF THE ELLIPTICAL

To adjust the stride length of the elliptical, first pull one of the adjustment knobs until the adjustment arm pivots freely. Pivot the adjustment arm until the adjustment knob is aligned with one of the holes in the crank arm, and gently release the knob into the hole.

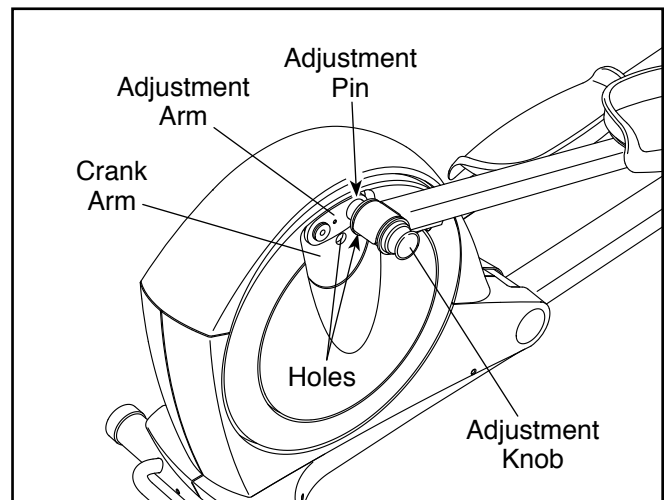

Pivot the adjustment arm back and forth slightly to make sure that the adjustment pin is engaged in one of the holes in the crank arm.

Adjust the stride length on the other side of the elliptical in the same way. **Make sure that both sides of the elliptical are adjusted to the same stride length.**

HOW TO EXERCISE ON THE ELLIPTICAL

To mount the elliptical, hold the upper body arms or the handlebars and step onto the pedal that is in the lowest position. Next, step onto the other pedal. Push the pedals until they begin to move with a continuous motion.

Note: The crank arms can turn in either direction. It is recommended that you turn the crank arms in the direction shown by the arrow; however, for variety, you can turn the crank arms in the opposite direction.

To dismount the elliptical, wait until the pedals come to a complete stop. **Note: The elliptical does not have a freewheel; the pedals will continue to move until the flywheel stops.** When the pedals are stationary, step off the highest pedal first. Then, step off the lowest pedal.

HOW TO ELIMINATE FLEXING IN THE CENTER OF THE ELLIPTICAL

If the elliptical flexes in the center during use, turn the leveling foot under the center of the frame until the flexing is eliminated.

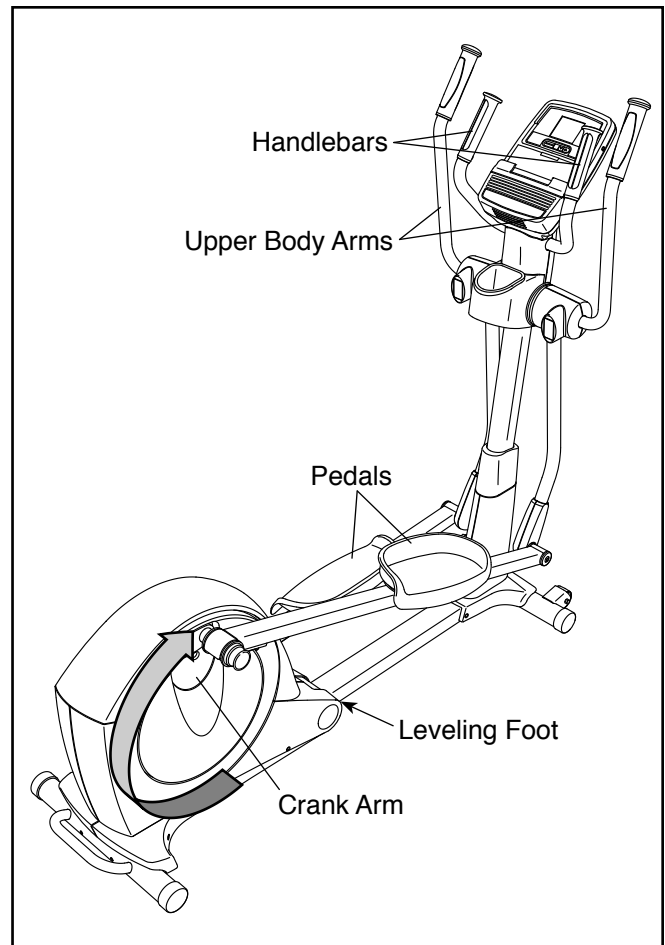

CONSOLE DIAGRAM

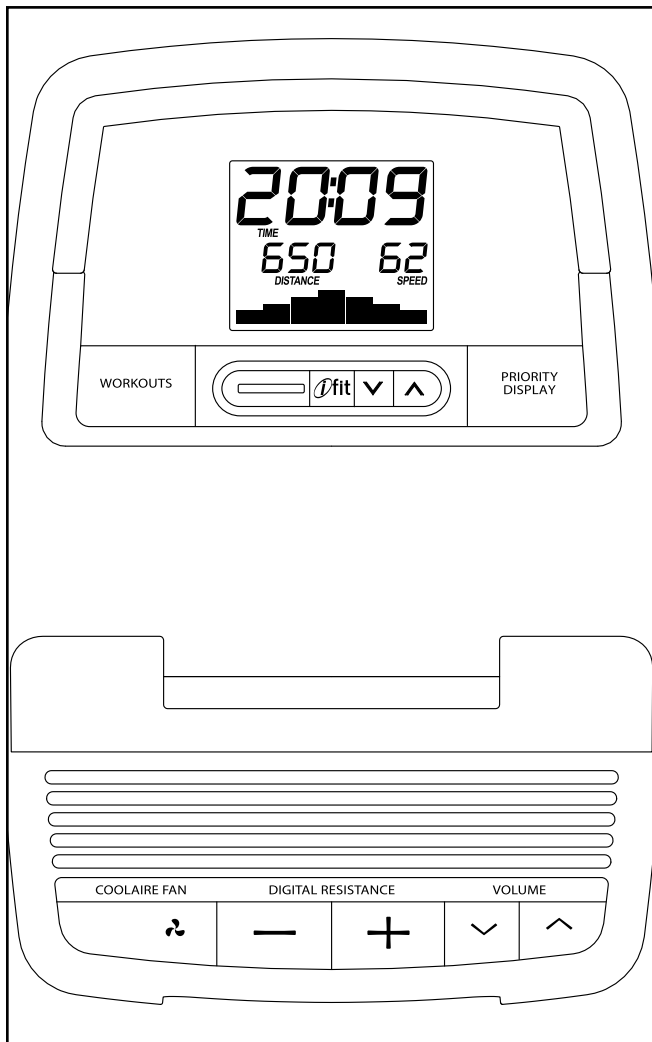

FEATURES OF THE CONSOLE

This console offers an array of features designed to make your workouts more effective and enjoyable.

The manual mode of the console allows you to change the resistance of the pedals with the touch of a button. As you exercise, the console will display continuous

exercise feedback. You can also measure your heart rate using the handgrip heart rate monitor or the optional chest heart rate monitor.

The console also offers the following workouts:

Eight preset workouts that automatically change the resistance of the pedals while guiding you through an effective workout.

Eight calorie goal workouts designed to help you burn a set number of calories. Each workout automatically controls the resistance of the pedals while counting the approximate number of calories you burn.

The console also features the iFit interactive workout system, which enables the console to accept iFit cards containing workouts designed to help you achieve specific fitness goals. For example, lose unwanted pounds with the 8-week Weight Loss workout.

iFit workouts control the resistance of the pedals while the voice of a personal trainer coaches you through your workouts. iFit cards are available separately. **To purchase iFit cards, go to www.iFit.com or call the telephone number on the front cover of this manual. iFit cards are also available at select stores.**

You can even connect your MP3 player or CD player to the console sound system and listen to your favorite music or audio books while you exercise.

To use the manual mode, see page 18. **To use a preset workout**, see page 20. **To use a calorie goal workout**, see page 21. **To use an iFit workout**, see page 22. **To use the sound system**, see page 22. **To change console settings**, see page 23.

Note: Before using the console, make sure that batteries are installed (see assembly step 13 on page 12). If there is a sheet of plastic on the display, remove the plastic.

HOW TO USE THE MANUAL MODE

1. **Begin pedaling or press any button on the console to turn on the console.**

A moment after you begin pedaling or press a button, the display will light.

2. **Select the manual mode.**

Each time you turn on the console, the manual mode will be selected. If you have selected a workout, reselect the manual mode by pressing the Workouts button repeatedly until zeros appear in the display.

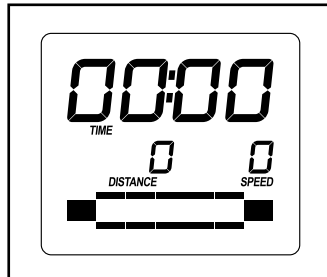

3. **Change the resistance of the pedals as desired.**

As you pedal, change the resistance of the pedals by pressing the Digital Resistance increase and decrease buttons.

Note: After you press the buttons, it will take a moment for the pedals to reach the selected resistance level.



4. **Follow your progress with the display.**

The lower left display

—As you exercise, the lower left display can show the elapsed time and the distance (total number of revolutions) that you have pedaled. Note: When a preset workout is selected, the display will show the time remaining in the workout instead of the elapsed time.



The lower right display—The lower right display can show your pedaling speed in revolutions per minute (rpm) and the approximate number of calories that you have burned. Note: When a calorie goal workout is selected, the display will count down the number of calories to be burned.



The display also shows your heart rate when you use the handgrip heart rate monitor or the optional chest heart rate monitor (see step 5 on page 18).

The upper display—The upper display can show the elapsed time, the distance that you have pedaled, your pedaling speed, and the approximate number of calories you have burned.

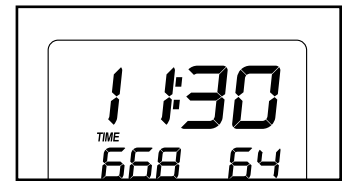

Press the Priority Display button repeatedly until the upper display shows the information that you are most interested in viewing. Note: While information is shown in the upper display, the same information will not be shown in the lower left or lower right display.

The lower display—The lower display will show a track representing 640 revolutions (1/4 mile or 400 m). As you exercise, indicators will appear in succession around the track until the entire track appears. The track will then disappear and the indicators will again begin to appear in succession.

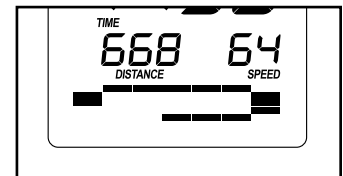

Adjust the volume level of the console by pressing the Volume increase and decrease buttons.

5. Measure your heart rate if desired.

You can measure your heart rate using either the handgrip heart rate monitor or the optional chest heart rate monitor (see page 23 for information about the optional chest heart rate monitor).

If there are sheets of plastic on the metal contacts on the handgrip heart rate monitor, remove the plastic. To measure your heart rate, hold the handgrip heart rate monitor with your palms resting against the metal contacts for approximately ten seconds. **Avoid moving your hands or gripping the contacts tightly.**

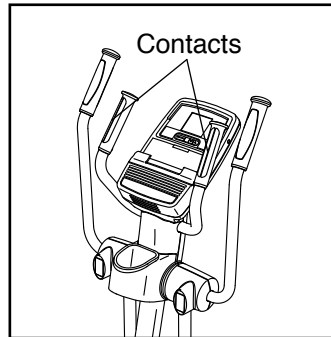

When your pulse is detected, a flashing heart symbol will appear in the display, and then your heart rate will appear. For the most accurate heart rate reading, hold the contacts for at least 15 seconds. Note: If you continue to



hold the handgrip heart rate monitor, the display will show your heart rate for up to 30 seconds.

If the display does not show your heart rate, make sure that your hands are positioned as described. Be careful not to move your hands excessively or to squeeze the metal contacts tightly. For optimal performance, clean the metal contacts using a soft cloth; **never use alcohol, abrasives, or chemicals to clean the contacts.**

6. Turn on the fan if desired.

Press the Coolaire Fan button repeatedly to turn on the fan or to turn off the fan. Note: If the pedals do not move for about thirty seconds, the fan will turn off automatically.

7. When you are finished exercising, the console will turn off automatically.

If the pedals do not move for several seconds, a tone will sound and the console will pause.

If the pedals do not move for several minutes and the buttons are not pressed, the console will turn off and the display will be reset.

HOW TO USE A PRESET WORKOUT

1. Begin pedaling or press any button on the console to turn on the console.

See step 1 on page 18.

2. Select a preset workout.

To select a preset workout, press the Workouts button repeatedly until the name of the desired workout appears in the display. The workout duration and a profile of the resistance levels for the workout will also appear in the display.

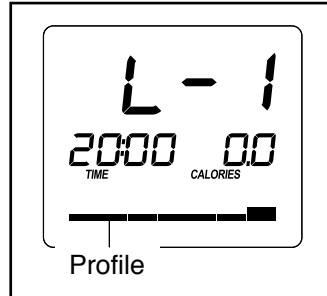

3. Begin pedaling to start the workout.

Each workout is divided into 20 or 30 one-minute segments. One resistance level is programmed for each segment. Note: The same resistance level may be programmed for consecutive segments.

The resistance level for the first segment will appear in the display for a few seconds. During the workout, the workout profile will show your progress (see the drawing above). The flashing segment of the profile represents the current segment of the workout. The height of the flashing segment indicates the resistance level for the current segment.

At the end of each segment of the workout, a series of tones will sound and the next segment of the profile will begin to flash. If a different resistance level is programmed for the next segment, the resistance level will appear in the display for a few seconds to alert you. The resistance of the pedals will then change.

If the resistance level for the current segment is too high or too low, you can manually override the setting by pressing the Digital Resistance buttons. **IMPORTANT: When the current segment of the workout ends, the pedals will automatically adjust to the resistance level programmed for the next segment.**

The workout will continue in this way until the last segment ends. To stop the workout at any time, stop pedaling. A tone will sound and the time will stop counting. To restart the workout, simply resume pedaling.

4. Follow your progress with the display.

See step 4 on page 18.

5. Measure your heart rate if desired.

See step 5 on page 19.

6. Turn on the fan if desired.

See step 6 on page 19.

7. When you are finished exercising, the console will turn off automatically.

See step 7 on page 19.

HOW TO USE A CALORIE GOAL WORKOUT

1. Begin pedaling or press any button on the console to turn on the console.

See step 1 on page 18.

2. Select a calorie goal workout.

To select a calorie goal workout, press the Workouts button repeatedly until the name of the desired workout appears in the display. The number of calories to be burned and a profile of the resistance levels for the workout will also appear in the display.

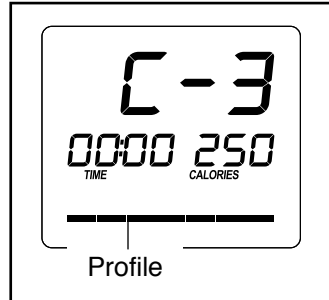

3. Begin pedaling to start the workout.

Each weight loss workout will help you burn approximately 150, 200, 250, 300, 350, 400, 450, or 500 calories. During each workout, the console will count down the approximate number of calories to be burned.

Each workout is divided into one-minute segments. One resistance level is programmed for each segment. Note: The same resistance level may be programmed for consecutive segments.

The resistance level for the first segment will appear in the display for a few seconds. During the workout, the workout profile will show your progress (see the drawing above). The flashing segment of the profile represents the current segment of the workout. The height of the flashing segment indicates the resistance level for the current segment.

At the end of each segment of the workout, a series of tones will sound and the next segment of the profile will begin to flash. If a different resistance level is programmed for the next segment, the resistance level will appear in the display for a few seconds to alert you. The resistance of the pedals will then change.

If the resistance level for the current segment is too high or too low, you can manually override the setting by pressing the Digital Resistance buttons. **IMPORTANT: When the current segment of the workout ends, the pedals will automatically adjust to the resistance level programmed for the next segment.**

The workout will continue in this way until you reach the calorie goal and the number of calories to be burned is zero. To stop the workout at any time, stop pedaling. A tone will sound and the time will stop counting. To restart the workout, simply resume pedaling.

Note: When you reach the calorie goal, the console will stop counting the elapsed time; however, if you continue pedaling, the console will continue to display your pedaling speed and the distance you have pedaled.

4. Follow your progress with the display.

See step 4 on page 18.

5. Measure your heart rate if desired.

See step 5 on page 19.

6. Turn on the fan if desired.

See step 6 on page 19.

7. When you are finished exercising, the console will turn off automatically.

See step 7 on page 19.

HOW TO USE AN iFIT WORKOUT

iFit cards are available separately. To purchase iFit cards, go to www.iFit.com or see the front cover of this manual. iFit cards are also available at select stores.

1. Begin pedaling or press any button on the console to turn on the console.

See step 1 on page 18.

2. Insert an iFit card and select a workout.

To use an iFit workout, insert an iFit card into the iFit slot; make sure that the iFit card is oriented so the metal contacts are face down and are facing the slot. When the iFit card is properly inserted, the indicator next to the slot will light and words will appear in the display.

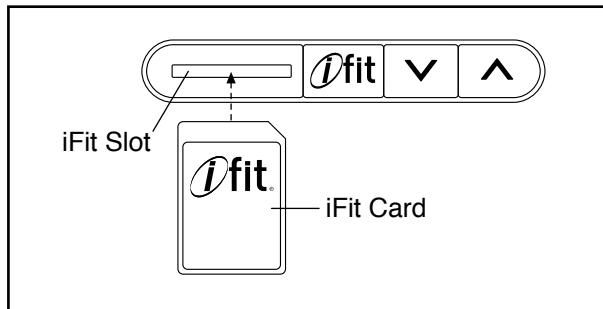

Next, select the desired workout on the iFit card by pressing the increase and decrease buttons next to the iFit slot.

A moment after you select a workout, the voice of a personal trainer will begin guiding you through your workout. iFit workouts function in the same way as preset workouts. To use the workout, see steps 3 to 7 starting on page 20.

3. When you are finished exercising, remove the iFit card.

Remove the iFit card when you are finished exercising. Store the iFit card in a secure place.

HOW TO USE THE SOUND SYSTEM

To play music or audio books through the console sound system while you exercise, plug a 3.5 mm male to 3.5 mm male audio cable (not included) into the jack on the console and into a jack on your MP3 player, CD player, or other personal audio player; **make sure that the audio cable is fully plugged in. Note: To purchase an audio cable, see your local electronics store.**

Next, press the play button on your personal audio player. Adjust the volume level using the Volume increase and decrease buttons on the console or the volume control on your personal audio player.

HOW TO CHANGE CONSOLE SETTINGS

The console features a user mode that allows you to select a backlight option for the console and to view console usage information.

1. Select the user mode.

To select the user mode, press and hold down the Priority Display button for a few seconds until the user mode information appears in the display.

2. Select a backlight option if desired.

The console has three backlight options. The ON option keeps the backlight on while the console is on. The AUTO option keeps the backlight on only while you are pedaling. The OFF option turns the backlight off.

The upper display will show the currently selected backlight option. Press the Digital Resistance decrease button repeatedly to select the desired backlight option.

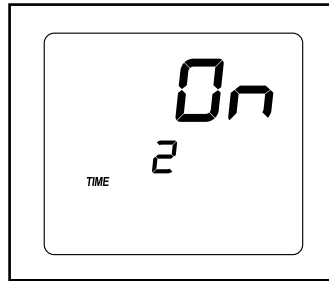

3. View console usage information if desired.

The lower left display will show the total number of hours that the console has been used since the elliptical was purchased.

4. Exit the user mode.

Press the Priority Display button to save the console settings and exit the user mode.

THE OPTIONAL CHEST HEART RATE MONITOR

Whether your goal is to burn fat or to strengthen your cardiovascular system, the key to achieving the best results is to maintain the proper heart rate during your workouts.

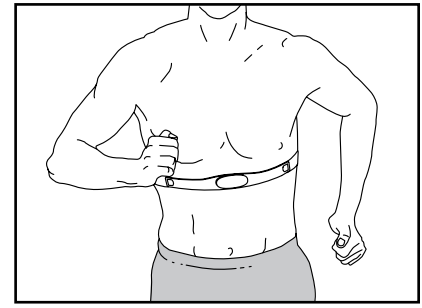

The optional chest heart rate monitor will enable you to continuously monitor your heart rate while you exercise, helping you to reach your personal fitness goals. **To purchase a chest heart rate monitor, please see the front cover of this manual.**

MAINTENANCE AND TROUBLESHOOTING

Inspect and tighten all parts of the elliptical regularly. Replace any worn parts immediately.

To clean the elliptical, use a damp cloth and a small amount of mild soap. **IMPORTANT: To avoid damage to the console, keep liquids away from the console and keep the console out of direct sunlight.**

CONSOLE TROUBLESHOOTING

Most console problems are the result of low batteries; see assembly step 13 on page 12 for replacement instructions.

If the console does not display your heart rate when you use the handgrip heart rate monitor, see step 5 on page 19.

HOW TO ADJUST THE REED SWITCH

If the console does not display correct feedback, the reed switch should be adjusted.

To adjust the reed switch, you must first remove the Top Shield (20). Using a flat screwdriver, release the tabs on the front and rear of the Top Shield and then remove the Top Shield.

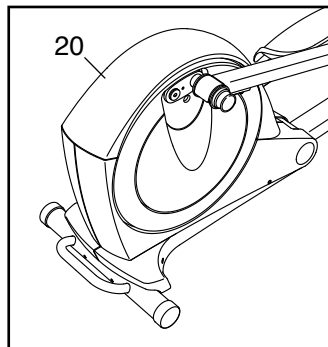

Next, locate the Reed Switch (69). Loosen, but do not remove, the M4 x 16mm Screw (93).

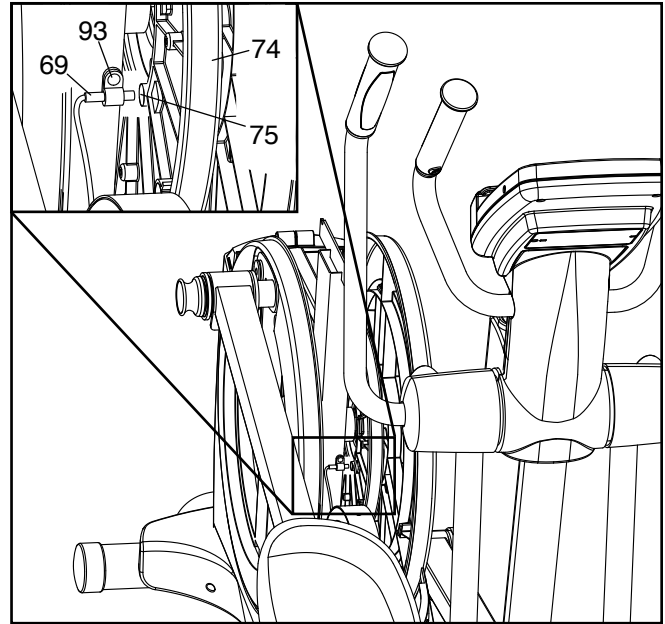

Next, rotate the Large Pulley (74) until a Magnet (75) is aligned with the Reed Switch (69). Slide the Reed Switch slightly toward or away from the Magnet. Then, retighten the M4 x 16mm Screw (93).

Rotate the Large Pulley (74) for a moment. Repeat these actions until the console displays correct feedback.

When the reed switch is correctly adjusted, reattach the top shield.

HOW TO ADJUST THE DRIVE BELT

If you can feel the pedals slip while you are pedaling, even when the resistance is adjusted to the highest level, the drive belt may need to be adjusted.

To adjust the drive belt, you must remove the top shield and the left shield (see the instructions below).

Using a flat screwdriver, release the tabs on the front and rear of the Top Shield (20) and then remove the Top Shield.

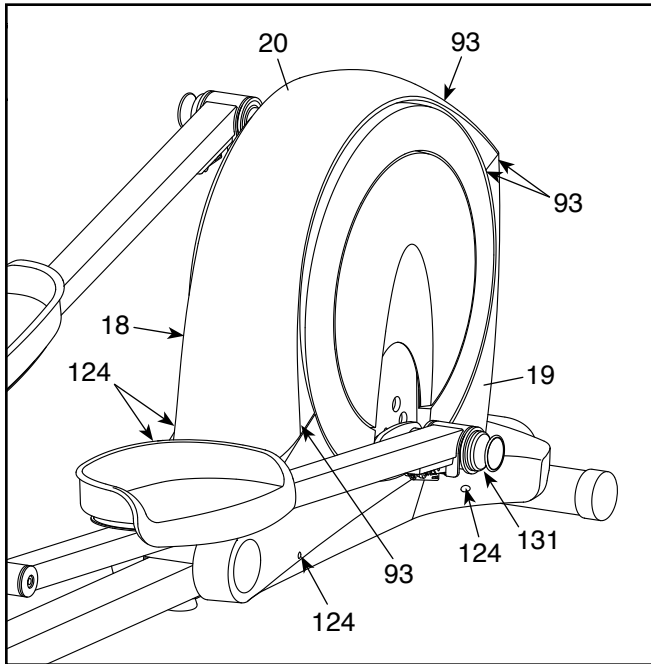

Next, remove the M4 x 16mm Screws (93), the M4 x 42mm Screws (124), and the M4 x 25mm Screw (131) from the Right and Left Shields (18, 19). **Make sure to note which size of Screw you remove from each hole.** Then, gently remove the Left Shield.

Loosen the Pivot Screw (97). Then, tighten the Belt Adjustment Screw (85) until the Drive Belt (38) is tight.

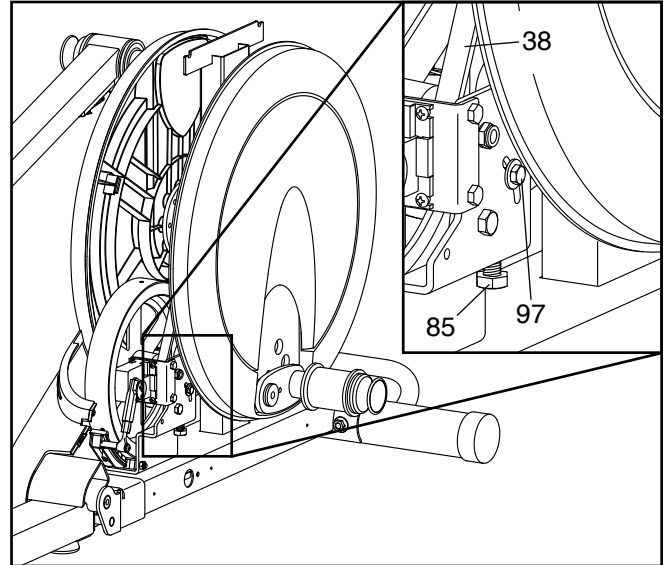

When the Drive Belt (38) is tight, tighten the Pivot Screw (97).

Then, reattach the left shield and the top shield.

EXERCISE GUIDELINES

⚠️ WARNING: Before beginning this or any exercise program, consult your physician. This is especially important for persons over age 35 or persons with pre-existing health problems.

The heart rate monitor is not a medical device. Various factors may affect the accuracy of heart rate readings. The heart rate monitor is intended only as an exercise aid in determining heart rate trends in general.

These guidelines will help you to plan your exercise program. For detailed exercise information, obtain a reputable book or consult your physician. Remember, proper nutrition and adequate rest are essential for successful results.

EXERCISE INTENSITY

Whether your goal is to burn fat or to strengthen your cardiovascular system, exercising at the proper intensity is the key to achieving results. You can use your heart rate as a guide to find the proper intensity level. The chart below shows recommended heart rates for fat burning and aerobic exercise.

165	155	145	140	130	125	115	❤️
145	138	130	125	118	110	103	❤️
125	120	115	110	105	95	90	❤️
<hr/>							
20	30	40	50	60	70	80	

To find the proper intensity level, find your age at the bottom of the chart (ages are rounded off to the nearest ten years). The three numbers listed above your age define your “training zone.” The lowest number is the heart rate for fat burning, the middle number is the heart rate for maximum fat burning, and the highest number is the heart rate for aerobic exercise.

Burning Fat—To burn fat effectively, you must exercise at a low intensity level for a sustained period of time. During the first few minutes of exercise, your body uses carbohydrate calories for energy. Only after the first few minutes of exercise does your body begin to use stored fat calories for energy. If your goal is to burn fat, adjust the intensity of your exercise until your heart rate is near the lowest number in your training zone. For maximum fat burning, exercise with your heart rate near the middle number in your training zone.

Aerobic Exercise—If your goal is to strengthen your cardiovascular system, you must perform aerobic exercise, which is activity that requires large amounts of oxygen for prolonged periods of time. For aerobic exercise, adjust the intensity of your exercise until your heart rate is near the highest number in your training zone.

WORKOUT GUIDELINES

Warming Up—Start with 5 to 10 minutes of stretching and light exercise. A warm-up increases your body temperature, heart rate, and circulation in preparation for exercise.

Training Zone Exercise—Exercise for 20 to 30 minutes with your heart rate in your training zone. (During the first few weeks of your exercise program, do not keep your heart rate in your training zone for longer than 20 minutes.) Breathe regularly and deeply as you exercise; never hold your breath.

Cooling Down—Finish with 5 to 10 minutes of stretching. Stretching increases the flexibility of your muscles and helps to prevent post-exercise problems.

EXERCISE FREQUENCY

To maintain or improve your condition, complete three workouts each week, with at least one day of rest between workouts. After a few months of regular exercise, you may complete up to five workouts each week, if desired. Remember, the key to success is to make exercise a regular and enjoyable part of your everyday life.

SUGGESTED STRETCHES

The correct form for several basic stretches is shown at the right. Move slowly as you stretch; never bounce.

1. Toe Touch Stretch

Stand with your knees bent slightly and slowly bend forward from your hips. Allow your back and shoulders to relax as you reach down toward your toes as far as possible. Hold for 15 counts, then relax. Repeat 3 times. Stretches: Hamstrings, back of knees and back.

2. Hamstring Stretch

Sit with one leg extended. Bring the sole of the opposite foot toward you and rest it against the inner thigh of your extended leg. Reach toward your toes as far as possible. Hold for 15 counts, then relax. Repeat 3 times for each leg. Stretches: Hamstrings, lower back and groin.

3. Calf/Achilles Stretch

With one leg in front of the other, reach forward and place your hands against a wall. Keep your back leg straight and your back foot flat on the floor. Bend your front leg, lean forward and move your hips toward the wall. Hold for 15 counts, then relax. Repeat 3 times for each leg. To cause further stretching of the achilles tendons, bend your back leg as well. Stretches: Calves, achilles tendons and ankles.

4. Quadriceps Stretch

With one hand against a wall for balance, reach back and grasp one foot with your other hand. Bring your heel as close to your buttocks as possible. Hold for 15 counts, then relax. Repeat 3 times for each leg. Stretches: Quadriceps and hip muscles.

5. Inner Thigh Stretch

Sit with the soles of your feet together and your knees outward. Pull your feet toward your groin area as far as possible. Hold for 15 counts, then relax. Repeat 3 times. Stretches: Quadriceps and hip muscles.

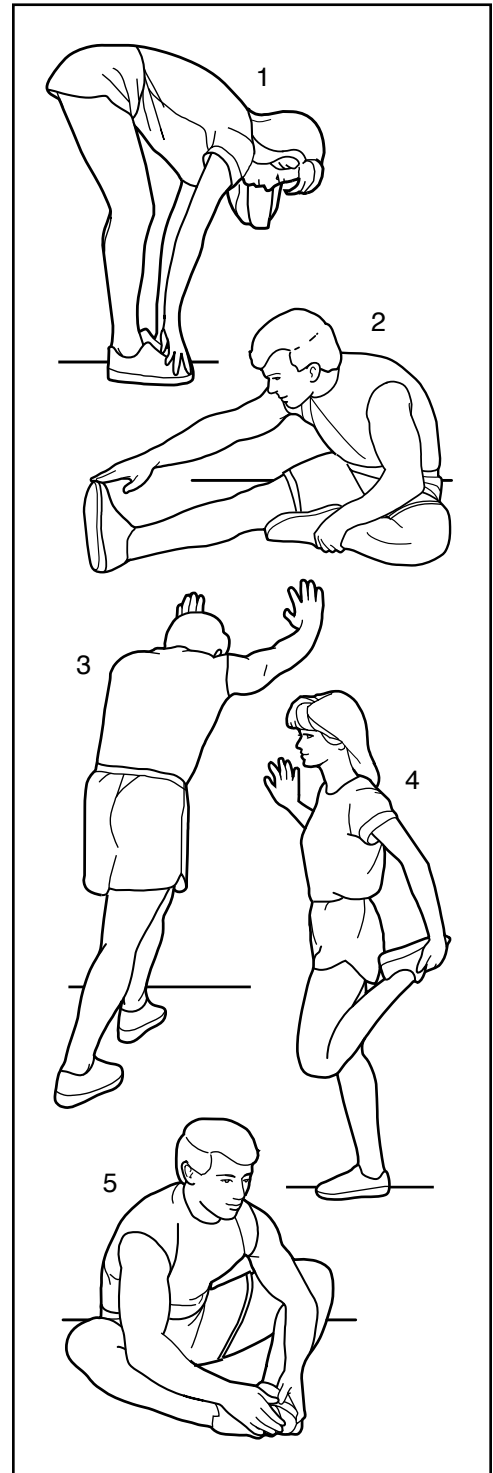

PART LIST

Model No. PFEVEL95910.1 R1213A

Key No.	Qty.	Description	Key No.	Qty.	Description
1	1	Frame	51	2	Latch Spring
2	1	Folding Frame	52	2	Latch Insert
3	1	Front Stabilizer	53	2	Adjustment Arm Spring
4	1	Rear Stabilizer	54	4	Leg Bearing Assembly
5	1	Upright	55	2	Leg Spacer
6	1	Right Upper Body Leg	56	2	Axle Cover
7	1	Left Upper Body Leg	57	2	Upright Bushing
8	1	Right Upper Body Arm	58	4	Pedal Arm Bushing
9	1	Left Upper Body Arm	59	1	Audio Cable
10	1	Right Handlebar	60	1	Wire Harness
11	1	Left Handlebar	61	1	Flywheel
12	1	Right Pedal Arm	62	1	6000ZZ Bearing
13	1	Left Pedal Arm	63	1	Frame Axle
14	1	Right Pedal	64	2	Frame Bushing
15	1	Left Pedal	65	1	Latch Bracket Axle
16	2	Disc	66	1	Latch Bracket Spring
17	2	Disc Cover	67	1	Latch Button
18	1	Right Shield	68	1	Button Housing
19	1	Left Shield	69	1	Reed Switch/Wire
20	1	Top Shield	70	1	Clamp
21	1	Right Frame Cover	71	1	Crank Hub
22	1	Left Frame Cover	72	1	Crank
23	1	Top Cover	73	1	Crank Spacer
24	1	Rear Upright Cover	74	1	Large Pulley
25	1	Front Upright Cover	75	2	Magnet
26	1	Water Bottle Holder	76	2	Folding Frame Bearing
27	2	Inner Leg Cover	77	1	Idler
28	2	Outer Leg Cover	78	1	Resistance Motor
29	1	Right Rear Leg Cover	79	1	Resistance Arm
30	1	Right Front Leg Cover	80	1	Resistance Wheel
31	1	Left Rear Leg Cover	81	1	Adjustment Bracket
32	1	Left Front Leg Cover	82	1	Motor Bracket
33	1	Console	83	1	C-magnet Bracket
34	2	Pulse Sensor/Wire	84	1	Flywheel Axle
35	2	Handgrip	85	1	Belt Adjustment Screw
36	2	Wheel	86	12	M8 x 28mm Screw
37	4	Stabilizer Cap	87	2	Small Snap Ring
38	1	Drive Belt	88	1	C-magnet Bracket Bolt
39	1	Right Crank Arm	89	4	Resistance Motor Screw
40	1	Left Crank Arm	90	1	M5 x 7mm Screw
41	1	Leveling Foot	91	1	M3.5 x 12mm Screw
42	1	Latch Bracket	92	1	M6 Locknut
43	2	Adjustment Arm	93	33	M4 x 16mm Screw
44	2	Adjustment Pin	94	2	M8 Jam Nut
45	2	Adjustment Knob	95	1	Ground Screw
46	2	Adjustment Sleeve	96	1	M6 Washer
47	4	Sleeve Bushing	97	1	Pivot Screw
48	1	Upright Axle	98	2	Motor Bracket Screw
49	2	Latch Housing	99	1	Idler Bolt
50	2	Latch	100	4	M10 x 80mm Screw

Key No.	Qty.	Description	Key No.	Qty.	Description
101	1	Anchored Zip Tie	118	2	Small Wave Washer
102	16	M8 x 16mm Screw	119	2	Medium Wave Washer
103	14	M8 Split Washer	120	2	M8 x 16mm x 2mm Washer
104	2	M10 x 60mm Screw	121	2	M8 x 23mm Shoulder Screw
105	2	M10 Locknut	122	1	3/8" x 1" Flange Screw
106	2	Short C-pin	123	4	M10 Split Washer
107	2	M10 x 25mm Screw	124	4	M4 x 42mm Screw
108	2	M10 x 32mm Washer	125	4	M4 x 42mm Flat Head Screw
109	2	M8 x 16mm Screw	126	2	M8 x 23mm x 2mm Washer
110	4	M8 x 23.5mm x 1mm Washer	127	2	Long C-pin
111	8	M6 x 12mm Screw	128	1	Bracket Snap Ring
112	8	M6 Split Washer	129	1	M5 Washer
113	2	M8 x 18mm Screw	130	2	Adjustment Nut
114	2	M8 x 32mm Washer	131	1	M4 x 25mm Screw
115	2	Large Wave Washer	*	-	User's Manual
116	2	Large Snap Ring	*	-	Assembly Tool
117	5	M4 x 19mm Flat Head Screw			

Note: Specifications are subject to change without notice. For information about ordering replacement parts, see the back cover of this manual. *These parts are not illustrated.

EXPLODED DRAWING A

Model No. PFEVEL95910.1 R1213A

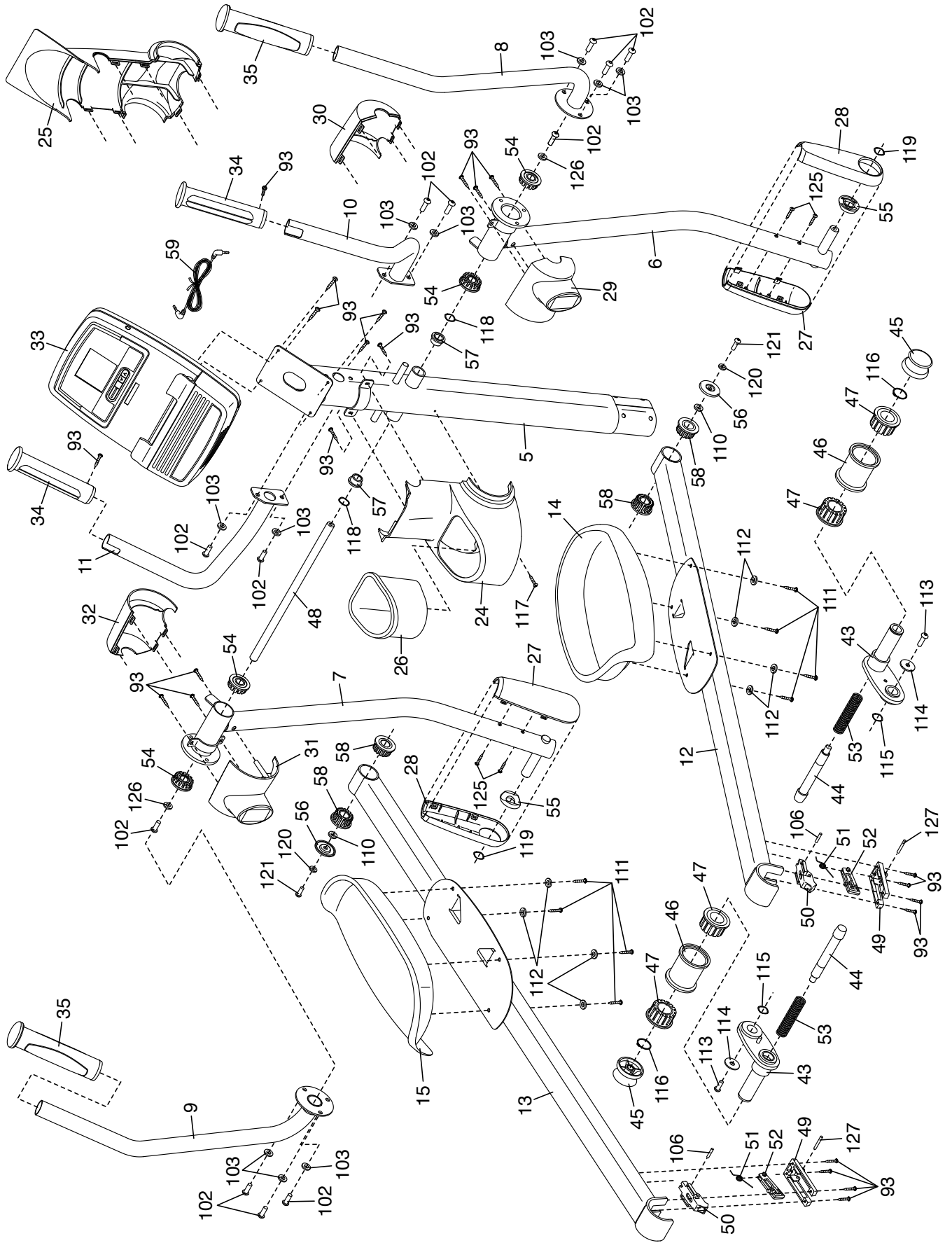

EXPLODED DRAWING B

Model No. PFEVEL95910.1 R1213A

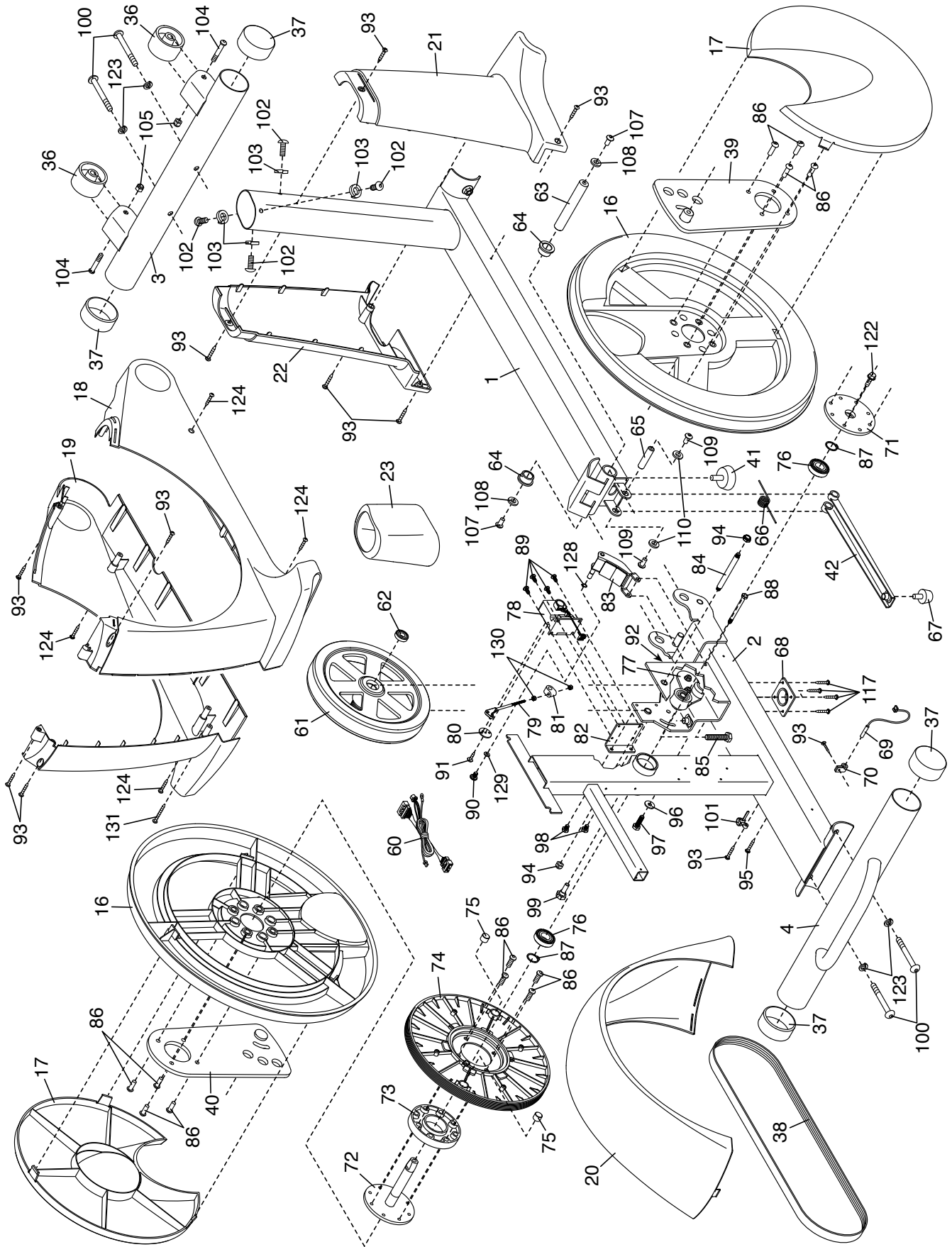

ORDERING REPLACEMENT PARTS

To order replacement parts, please see the front cover of this manual. To help us assist you, be prepared to provide the following information when contacting us:

- the model number and serial number of the product (see the front cover of this manual)
- the name of the product (see the front cover of this manual)
- the key number and description of the replacement part(s) (see the PART LIST and the EXPLODED DRAWING near the end of this manual)

RECYCLING INFORMATION

This electronic product must not be disposed of in municipal waste. To preserve the environment, this product must be recycled after its useful life as required by law.

Please use recycling facilities that are authorized to collect this type of waste in your area. In doing so, you will help to conserve natural resources and improve European standards of environmental protection. If you require more information about safe and correct disposal methods, please contact your local city office or the establishment where you purchased this product.

