

PRO-FORM[®]

290 SPX

www.proform.com

Model No. PFEX02909.2

Serial No. _____

Write the serial number in the space above for reference.

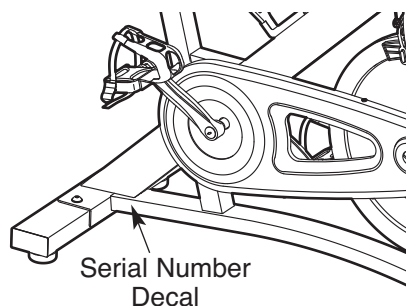

USER'S MANUAL

QUESTIONS?

If you have questions, or if parts are damaged or missing, **DO NOT CONTACT THE STORE**; please contact Customer Care.

IMPORTANT: Please register this product (see the limited warranty on the back cover of this manual) before contacting Customer Care.

CALL TOLL-FREE:

1-888-533-1333

Mon.–Fri. 6 a.m.–6 p.m. MT

Sat. 8 a.m.–4 p.m. MT

ON THE WEB:

www.proformservice.com

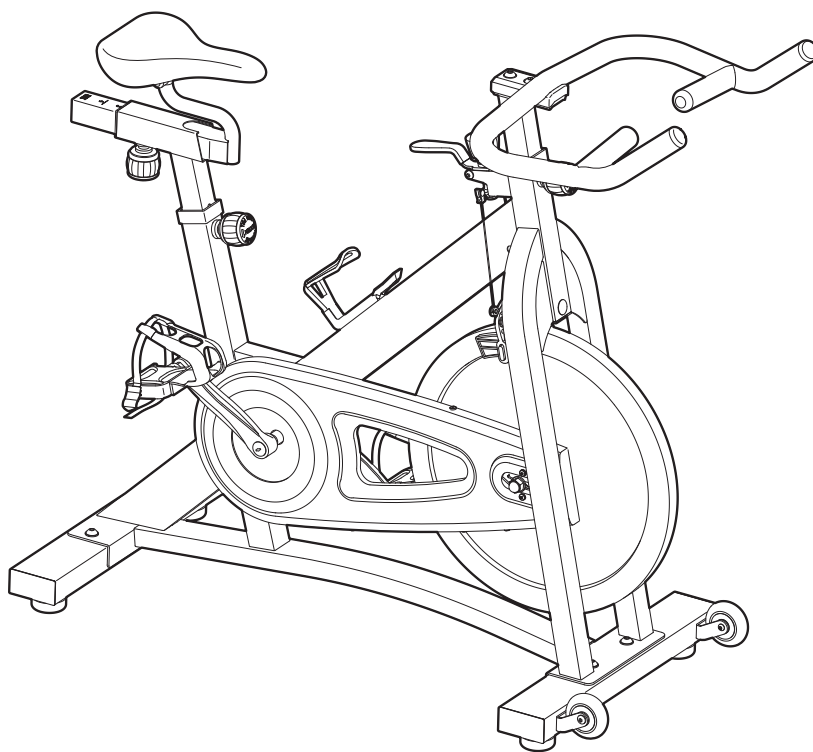

CAUTION

Read all precautions and instructions in this manual before using this equipment. Keep this manual for future reference.



TABLE OF CONTENTS

WARNING DECAL PLACEMENT2

IMPORTANT PRECAUTIONS3

BEFORE YOU BEGIN4

ASSEMBLY5

HOW TO USE THE EXERCISE BIKE8

PART LIST10

EXPLODED DRAWING11

ORDERING REPLACEMENT PARTSBack Cover

LIMITED WARRANTYBack Cover

WARNING DECAL PLACEMENT

This drawing shows the location(s) of the warning decal(s). **If a decal is missing or illegible, see the front cover of this manual and request a free replacement decal. Apply the decal in the location shown.**
 Note: The decal(s) may not be shown at actual size.

CAUTION

To stop, reduce your pedal speed in a controlled way.

To stop quickly, use the brake.

Pedals will continue to spin so use caution when slowing and stopping.

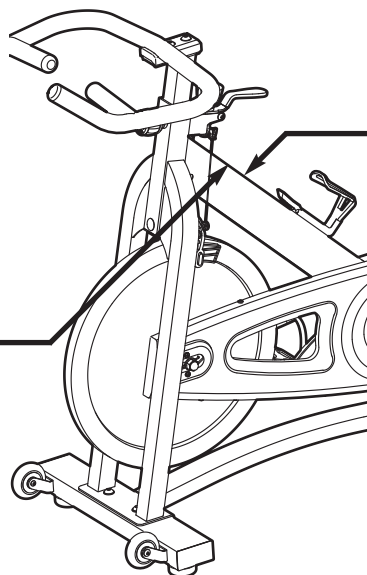

WARNING

- Misuse of this machine may result in serious injury.
- Read user's manual prior to use and follow all warnings and instructions.
- Do not allow children on or around machine.
- Pedals continue to spin when you stop pedaling.
- Spinning pedals can cause injury.
- Reduce pedal speed in a controlled manner.
- User weight must not exceed 250 pounds.
- This product should always be used on a level surface.
- This product is not intended for therapeutic use.
- Set the resistance to maximum when the bike is not in use.
- Replace label if damaged, illegible, or removed.



IMPORTANT PRECAUTIONS

⚠ WARNING: To reduce the risk of serious injury, read all important precautions and instructions in this manual and all warnings on your exercise bike before using your exercise bike. ICON assumes no responsibility for personal injury or property damage sustained by or through the use of this product.

1. Before beginning any exercise program, consult your physician. This is especially important for persons over age 35 or persons with pre-existing health problems.
2. Use the exercise bike only as described in this manual.
3. It is the responsibility of the owner to ensure that all users of the exercise bike are adequately informed of all precautions.
4. The exercise bike is intended for home use only. Do not use the exercise bike in a commercial, rental, or institutional setting.
5. Keep the exercise bike indoors, away from moisture and dust. Do not put the exercise bike in a garage or covered patio, or near water.
6. Place the exercise bike on a level surface, with a mat beneath it to protect the floor or carpet. Make sure that there is at least 2 ft. (0.6 m) of clearance around the exercise bike.
7. Inspect and properly tighten all parts regularly. Replace any worn parts immediately.
8. Keep children under age 12 and pets away from the exercise bike at all times.
9. Wear appropriate clothes while exercising; do not wear loose clothes that could become caught on the exercise bike. Always wear athletic shoes for foot protection.
10. The exercise bike should not be used by persons weighing more than 250 lbs. (113 kg).
11. Always keep your back straight while using the exercise bike; do not arch your back.
12. The exercise bike does not have a freewheel; the pedals will continue to move until the flywheel stops. Reduce your pedaling speed in a controlled way.
13. To stop the flywheel quickly, press the brake lever downward.
14. When the exercise bike is not in use, tighten the resistance knob completely to prevent the flywheel from moving.
15. To avoid damaging the brake pads, do not lubricate the brake pads.
16. Over exercising may result in serious injury or death. If you feel faint or if you experience pain while exercising, stop immediately and cool down.

BEFORE YOU BEGIN

Thank you for selecting the new PROFORM® 290 SPX exercise bike. Cycling is an effective exercise for increasing cardiovascular fitness, building endurance, and toning the body. The 290 SPX exercise bike provides a selection of features designed to make your workouts at home more effective and enjoyable.

For your benefit, read this manual carefully before you use the exercise bike. If you have questions

after reading this manual, please see the front cover of this manual. To help us assist you, note the product model number and serial number before contacting us. The model number and the location of the serial number decal are shown on the front cover of this manual.

Before reading further, please familiarize yourself with the parts that are labeled in the drawing below.

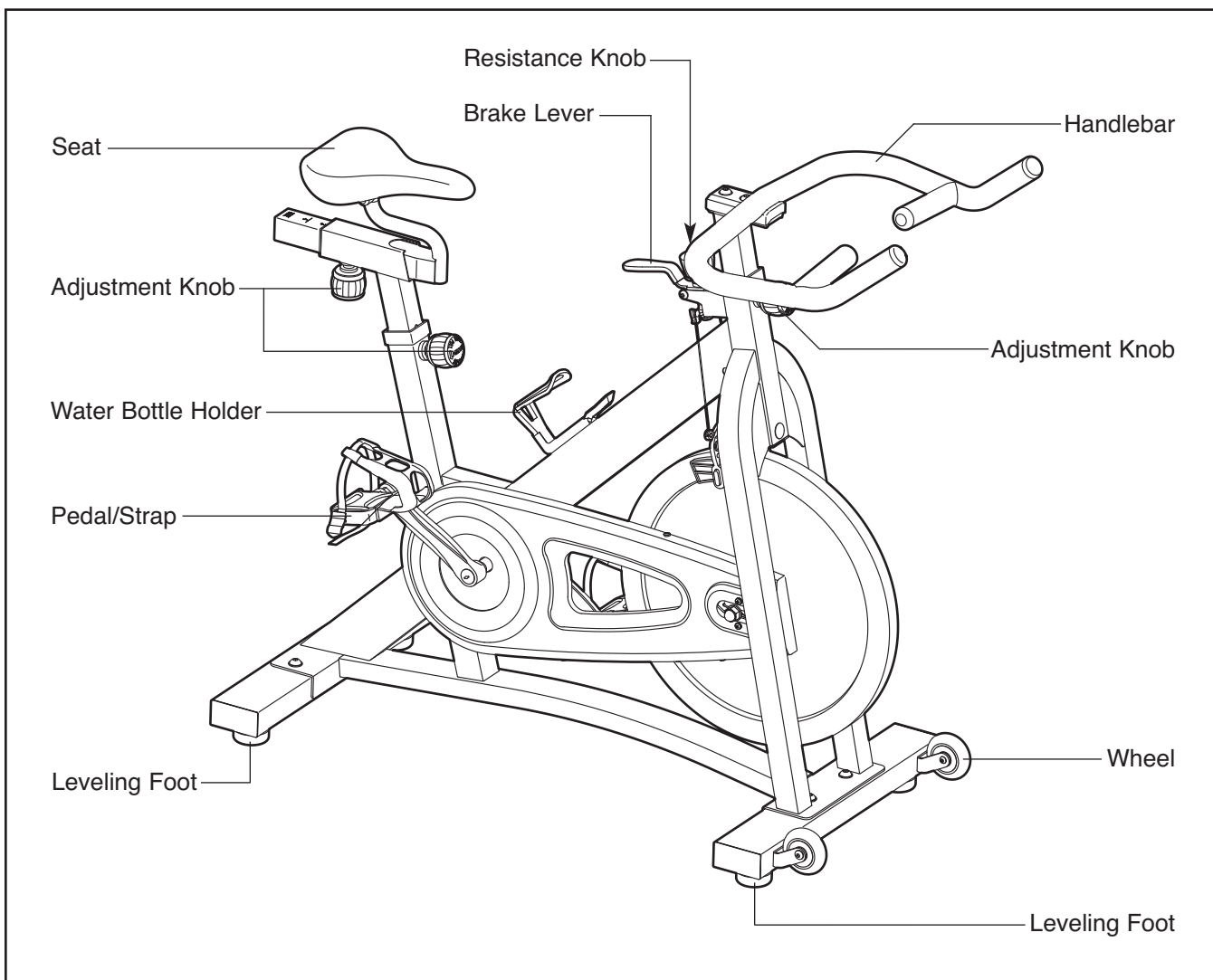

ASSEMBLY

Assembly requires two persons. Place all parts of the exercise bike in a cleared area and remove the packing materials. Do not dispose of the packing materials until assembly is completed.

In addition to the included tool(s), assembly requires an adjustable wrench  and a Phillips screwdriver .

Note: If a part is not in the hardware kit, check to see if it has been preattached.

1. Identify the Rear Stabilizer (7), which does not have wheels.

Attach the Rear Stabilizer (7) to the Frame (1) with two M10 x 25mm Screws (34) and two M10 Washers (33).

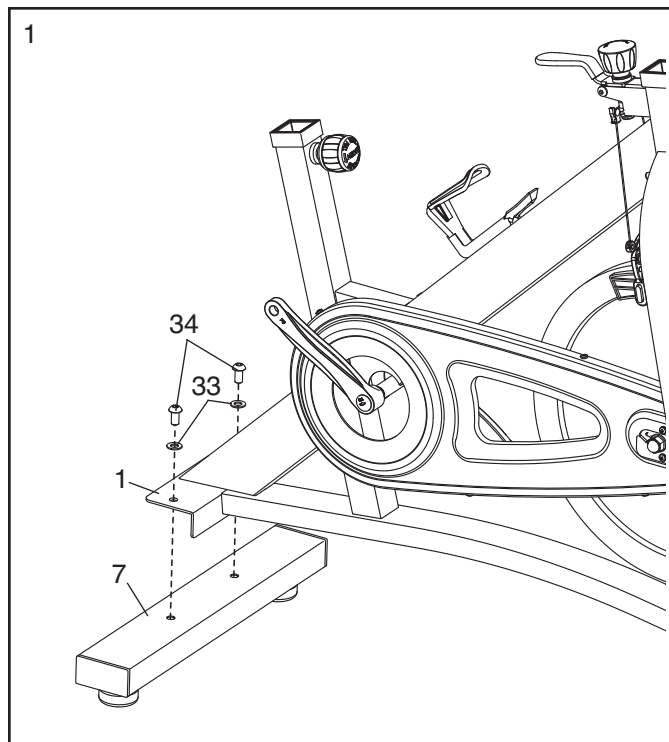

2. Orient the Front Stabilizer (8) so that the Wheels (21) are in the position shown.

Attach the Front Stabilizer (8) to the Frame (1) with two M10 x 25mm Screws (34) and two M10 Washers (33).

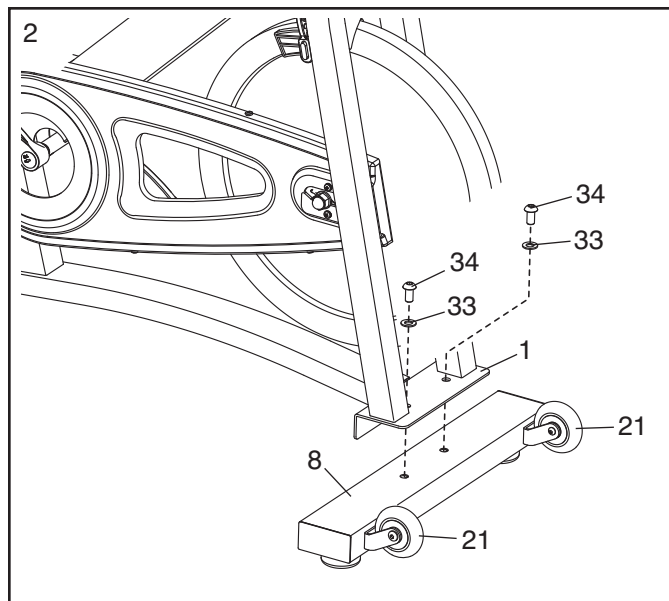

3. Identify the Right Pedal (35), which is marked with an "R."

Using an adjustable wrench, **firmly tighten** the Right Pedal (35) **clockwise** into the Right Crank Arm (31).

Tighten the Left Pedal (61) **counterclockwise** into the Left Crank Arm (not shown).

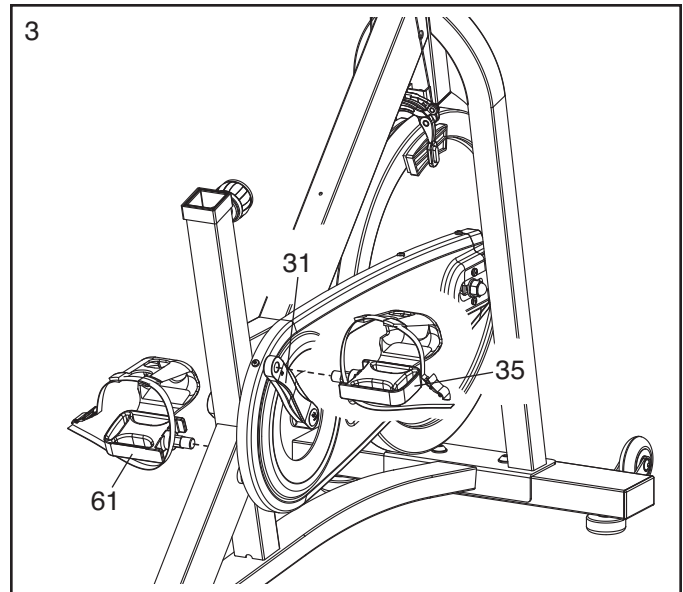

4. Orient the Handlebar Post (4) as shown.

Locate the Adjustment Knob (23) on the front of the Frame (1). Loosen the Adjustment Knob and pull it outward. Then, insert the Handlebar Post (4) into the Frame.

Move the Handlebar Post (4) upward or downward to the desired position, release the Adjustment Knob (23) into an adjustment hole in the Handlebar Post, and then tighten the Adjustment Knob. **Make sure that the Adjustment Knob is firmly engaged in an adjustment hole.**

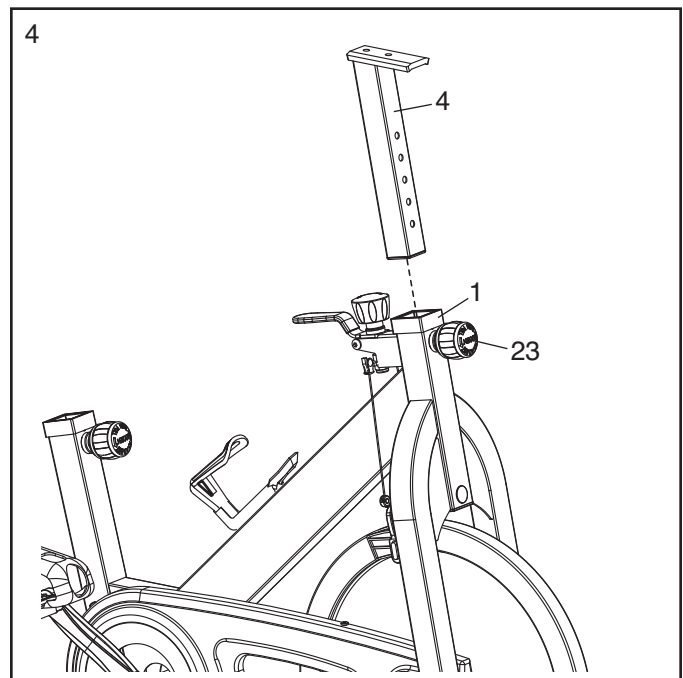

5. Attach the Handlebar (5) to the Handlebar Post (4) with two M10 x 25mm Screws (34) and two M10 Washers (33).

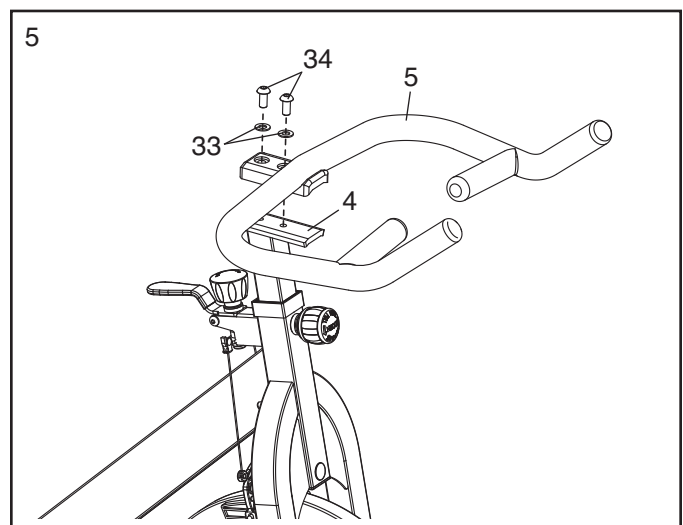

6. Orient the Seat Post (2) as shown.

Locate the Adjustment Knob (23) on the rear of the Frame (1). Loosen the Adjustment Knob and pull it outward. Then, insert the Seat Post (2) into the Frame.

Move the Seat Post (2) upward or downward to the desired position, release the Adjustment Knob (23) into an adjustment hole in the Seat Post, and then tighten the Adjustment Knob.

Make sure that the Adjustment Knob is firmly engaged in an adjustment hole.

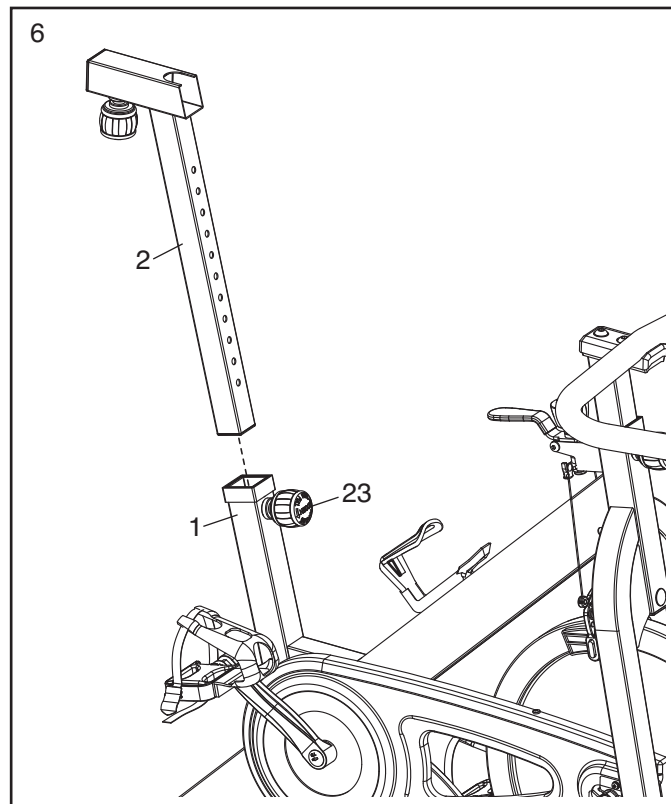

7. Orient the Seat (22) and the Seat Carriage (3) as shown.

See the inset drawing. Attach the Seat (22) to the Seat Carriage (3) with two M8 Hex Nuts (27). **Make sure that the nose of the Seat is pointing straight ahead before you tighten the Hex Nuts.**

Locate the Adjustment Knob (23) on the Seat Post (2). Loosen the Adjustment Knob and pull it outward. Then, insert the Seat Carriage (3) into the Seat Post.

Slide the Seat Carriage (3) to the desired position and then release the Adjustment Knob (23) into one of the adjustment holes in the Seat Carriage. **Make sure that the Adjustment Knob is firmly engaged in an adjustment hole.**

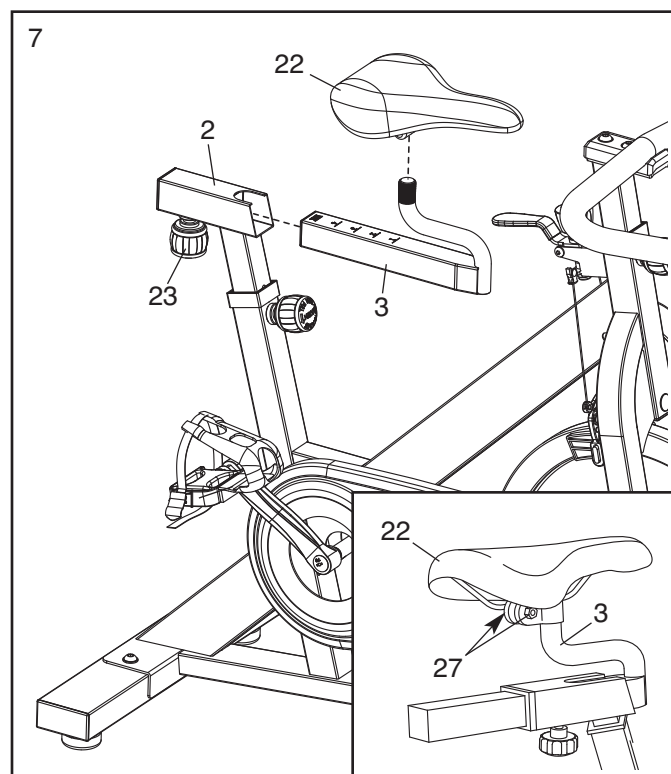

8. **Make sure that all parts are properly tightened before you use the exercise bike.** Note: After assembly is completed, some extra parts may be left over. Place a mat beneath the exercise bike to protect the floor.

HOW TO USE THE EXERCISE BIKE

HOW TO ADJUST THE ANGLE OF THE SEAT

You can adjust the angle of the seat to the position that is most comfortable. You can also slide your seat forward or backward to increase your comfort or to adjust the distance to the handlebar.

To adjust the seat, see the inset drawing in assembly step 7 on page 7. Loosen the nuts on the seat clamp a few turns, and then tilt the seat upward or downward or slide the seat forward or backward to the desired position. Then, retighten the nuts.

HOW TO ADJUST THE HORIZONTAL POSITION OF THE SEAT

To adjust the position of the seat, first loosen the adjustment knob and pull it downward. Then, move the seat forward or backward, release the adjustment knob into an adjustment hole in the seat carriage, and firmly tighten the adjustment knob. **Make sure that the adjustment knob is engaged in an adjustment hole.**

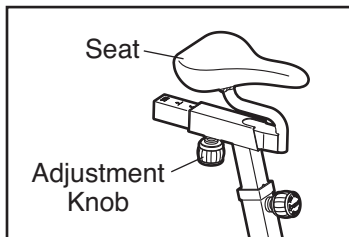

HOW TO ADJUST THE SEAT POST

For effective exercise, the seat should be at the proper height. As you pedal, there should be a slight bend in your knees when the pedals are in the lowest position.

To adjust the height of the seat post, first loosen the adjustment knob and pull it outward. Then, move the seat post upward or downward, release the adjustment knob into an adjustment hole in the seat post, and firmly tighten the adjustment knob. **Make sure that the adjustment knob is engaged in an adjustment hole.**

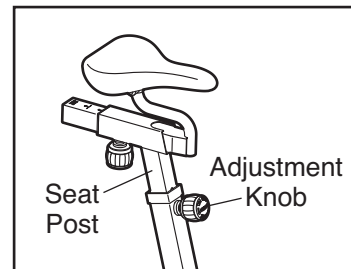

HOW TO ADJUST THE HANDLEBAR POST

To adjust the height of the handlebar post, first loosen the adjustment knob and pull it outward. Then, move the handlebar post upward or downward, release the adjustment knob into an adjustment hole in the handlebar post, and firmly tighten the adjustment knob. **Make sure that the adjustment knob is engaged in an adjustment hole.**

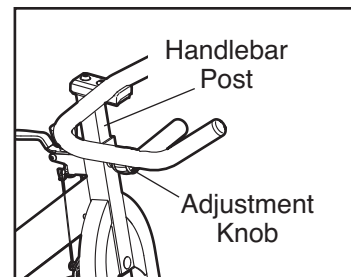

HOW TO ADJUST THE PEDAL STRAPS

To tighten the pedal straps (see the drawing on page 4), simply pull the ends of the pedal straps. To loosen the pedal straps, press and hold the tabs on the buckles, adjust the pedal straps to the desired position, and then release the tabs.

HOW TO ADJUST THE PEDALING RESISTANCE

To increase the resistance of the pedals, turn the resistance knob clockwise; to decrease the resistance, turn the resistance knob counterclockwise.

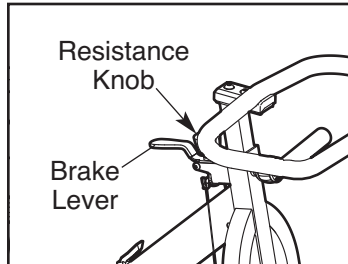

To stop the flywheel, push the brake lever downward. The flywheel should quickly come to a complete stop.

IMPORTANT: When the exercise bike is not in use, tighten the resistance knob completely.

HOW TO LEVEL THE EXERCISE BIKE

If the exercise bike rocks slightly on your floor during use, turn one or both of the leveling feet on the front or rear stabilizer (see the drawing on page 4) until the rocking motion is eliminated.

HOW TO MAINTAIN THE EXERCISE BIKE

Inspect and tighten all parts of the exercise bike regularly. Replace any worn parts immediately.

To clean the exercise bike, use a damp cloth and a small amount of mild detergent. **IMPORTANT: To avoid damage to the console, keep liquids away from the console and keep the console out of direct sunlight.**

PART LIST

Model No. PFEX02909.2 R0811A

Key No.	Qty.	Description	Key No.	Qty.	Description
1	1	Frame	35	1	Right Pedal/Strap
2	1	Seat Post	36	1	Flywheel
3	1	Seat Carriage	37	1	Flywheel Axle
4	1	Handlebar Post	38	2	Flywheel Bracket
5	1	Handlebar	39	1	Sleeve
6	2	M12 Hex Nut	40	2	M8 Locknut
7	1	Rear Stabilizer	41	2	Brake Pad
8	1	Front Stabilizer	42	1	Brake Clamp
9	1	Brake Lever	43	1	Small Knob Washer
10	1	Felt Washer	44	2	Flywheel Bearing
11	1	Resistance Knob	45	2	Crank Bearing
12	1	Left Crank Arm	46	2	M10 x 40mm Screw
13	10	#8 x 13mm Screw	47	1	Flywheel Sprocket
14	1	Right Shield	48	2	Snap Ring
15	1	Left Shield	49	4	M10 Hex Nut
16	4	Leveling Foot	50	1	8mm Bolt Set
17	2	Seat Post Bushing	51	1	M6 x 30mm Bolt
18	4	Stabilizer Cap	52	2	Brake Pad Mount
19	3	Post Cap	53	2	Crank Nut
20	1	Shield Cover	54	2	#8 x 25mm Screw
21	2	Wheel	55	3	M12 Thin Hex Nut
22	1	Seat	56	1	M6 Flange Nut
23	3	Adjustment Knob	57	2	Spanner Nut
24	1	Brake Cap	58	1	M10 Locknut
25	1	Frame Cap	59	2	M5 x 12mm Screw
26	2	11.5mm Plastic Spacer	60	1	Water Bottle Holder
27	2	M8 Hex Nut	61	1	Left Pedal/Strap
28	1	Chain	62	1	Handlebar Post Bushing
29	2	Bracket Washer	63	2	Brake Cable
30	1	Crank Axle	64	1	Caliper Brake
31	1	Right Crank Arm/Crank Wheel	65	2	M5 Washer
32	2	Crank Cap	66	2	M10 Nut
33	6	M10 Washer	*	–	Assembly Tool
34	6	M10 x 25mm Screw	*	–	User's Manual

Note: Specifications are subject to change without notice. For information about ordering replacement parts, see the back cover of this manual. *These parts are not illustrated.

ORDERING REPLACEMENT PARTS

To order replacement parts, please see the front cover of this manual. To help us assist you, be prepared to provide the following information when contacting us:

- the model number and serial number of the product (see the front cover of this manual)
- the name of the product (see the front cover of this manual)
- the key number and description of the replacement part(s) (see the PART LIST and the EXPLODED DRAWING near the end of this manual)

LIMITED WARRANTY

IMPORTANT: You must register this product within 30 days of the purchase date to avoid added fees for service needed under warranty. Go to www.proformservice.com/registration.

ICON Health & Fitness, Inc. (ICON) warrants this product to be free from defects in workmanship and material, under normal use and service conditions. The frame is warranted for five (5) years from the date of purchase. Parts and labor are warranted for ninety (90) days from the date of purchase.

This warranty extends only to the original purchaser (customer). ICON's obligation under this warranty is limited to repairing or replacing, at ICON's option, the product through one of its authorized service centers. All repairs for which warranty claims are made must be preauthorized by ICON. If the product is shipped to a service center, freight charges to and from the service center will be the customer's responsibility. If replacement parts are shipped while the product is under warranty, the customer will be responsible for a minimal handling charge. For in-home service, the customer will be responsible for a minimal trip charge. This warranty does not extend to freight damage to the product. This warranty will automatically be voided if the product is used as a store display model, if the product is purchased or transported outside the USA, if all instructions in this manual are not followed, if the product is abused or improperly or abnormally used, or if the product is used for commercial or rental purposes. No other warranty beyond that specifically set forth above is authorized by ICON.

ICON is not responsible or liable for indirect, special, or consequential damages arising out of or in connection with the use or performance of the product; damages with respect to any economic loss, loss of property, loss of revenues or profits, loss of enjoyment or use, or costs of removal or installation; or other consequential damages of any kind. Some states do not allow the exclusion or limitation of incidental or consequential damages. Accordingly, the above limitation may not apply to the customer.

The warranty extended hereunder is in lieu of any and all other warranties, and any implied warranties of merchantability or fitness for a particular purpose are limited in their scope and duration to the terms set forth herein. Some states do not allow limitations on how long an implied warranty lasts. Accordingly, the above limitation may not apply to the customer.

This warranty provides specific legal rights; the customer may have other rights that vary from state to state.

ICON Health & Fitness, Inc., 1500 S. 1000 W., Logan, UT 84321-9813