

PRO-FORM[®]

490 SPX

www.proform.com

Model No. PFEX03910.2

Serial No. _____

Write the serial number in the space above for reference.

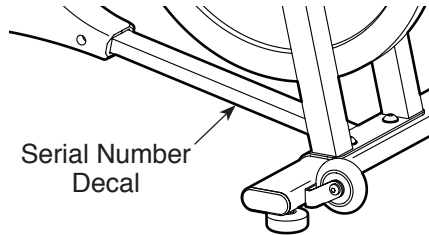

USER'S MANUAL

ACTIVATE YOUR WARRANTY

To register your product and activate your warranty today, go to www.proformservice.com/registration.

CUSTOMER CARE

For service at any time, go to www.proformservice.com.

Or call 1-888-533-1333
Mon.–Fri. 6 a.m.–6 p.m. MT
Sat. 8 a.m.–4 p.m. MT

Please do not contact the store.

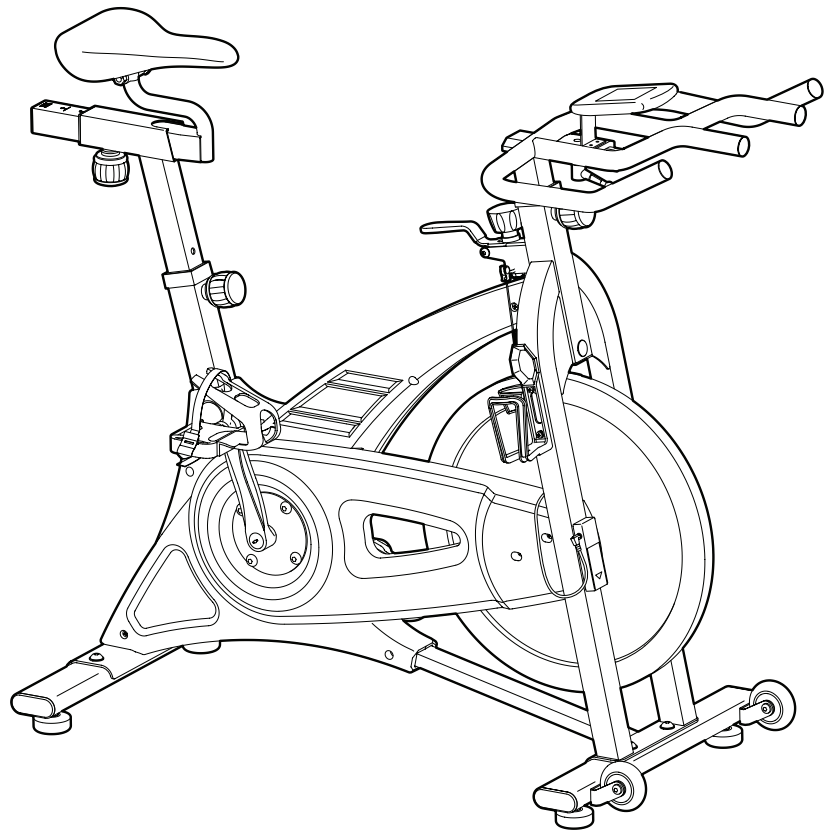

⚠ CAUTION

Read all precautions and instructions in this manual before using this equipment. Keep this manual for future reference.



TABLE OF CONTENTS

WARNING DECAL PLACEMENT 2

IMPORTANT PRECAUTIONS..... 3

BEFORE YOU BEGIN..... 5

ASSEMBLY..... 6

HOW TO USE THE EXERCISE BIKE..... 12

FCC INFORMATION..... 19

EXERCISE GUIDELINES..... 20

PART LIST..... 22

EXPLODED DRAWING..... 23

ORDERING REPLACEMENT PARTS Back Cover

LIMITED WARRANTY..... Back Cover

WARNING DECAL PLACEMENT

This drawing shows the location(s) of the warning decal(s). **If a decal is missing or illegible, see the front cover of this manual and request a free replacement decal. Apply the decal in the location shown.** Note: The decal(s) may not be shown at actual size.

CAUTION

To stop, reduce your pedal speed in a controlled way.

To stop quickly, use the brake.

Pedals will continue to spin so use caution when slowing and stopping.

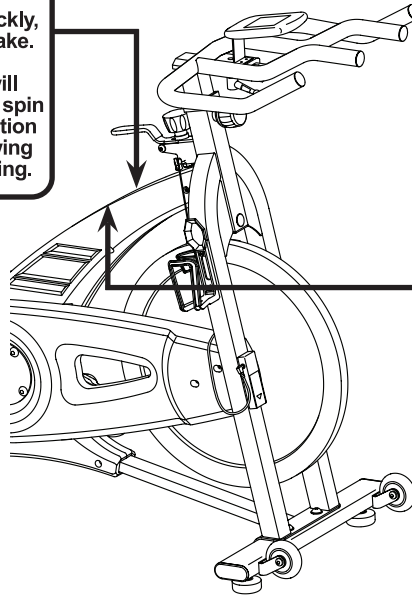

WARNING

- Misuse of this machine may result in serious injury.
- Read user's manual prior to use and follow all warnings and instructions.
- Do not allow children on or around machine.
- Pedals continue to spin when you stop pedaling.
- Spinning pedals can cause injury.
- Reduce pedal speed in a controlled manner.
- User weight must not exceed 275 pounds.
- This product should always be used on a level surface.
- This product is not intended for therapeutic use.
- Set the resistance to maximum when the bike is not in use.
- Replace label if damaged, illegible, or removed.



IMPORTANT PRECAUTIONS

⚠ WARNING: To reduce the risk of serious injury, read all important precautions and instructions in this manual and all warnings on your exercise bike before using your exercise bike. ICON assumes no responsibility for personal injury or property damage sustained by or through the use of this product.

1. It is the responsibility of the owner to ensure that all users of the exercise bike are adequately informed of all precautions.
2. Before beginning any exercise program, consult your physician. This is especially important for persons over age 35 or persons with pre-existing health problems.
3. Use the exercise bike only as described in this manual.
4. The exercise bike is intended for home use only. Do not use the exercise bike in a commercial, rental, or institutional setting.
5. Keep the exercise bike indoors, away from moisture and dust. Do not put the exercise bike in a garage or covered patio, or near water.
6. Place the exercise bike on a level surface, with a mat beneath it to protect the floor or carpet. Make sure that there is at least 2 ft. (0.6 m) of clearance around the exercise bike.
7. Inspect and properly tighten all parts regularly. Replace any worn parts immediately.
8. Keep children under age 12 and pets away from the exercise bike at all times.
9. Wear appropriate clothes while exercising; do not wear loose clothes that could become caught on the exercise bike. Always wear athletic shoes for foot protection.
10. The exercise bike should not be used by persons weighing more than 275 lbs. (125 kg).
11. Be careful when mounting and dismounting the exercise bike.
12. Always keep your back straight while using the exercise bike; do not arch your back.
13. The exercise bike does not have a freewheel; the pedals will continue to move until the flywheel stops. Reduce your pedaling speed in a controlled way.
14. To stop the flywheel quickly, press the brake lever downward.
15. When the exercise bike is not in use, tighten the resistance knob completely to prevent the flywheel from moving.
16. To avoid damaging the brake pads, do not lubricate the brake pads.
17. Over exercising may result in serious injury or death. If you feel faint or if you experience pain while exercising, stop immediately and cool down.

PROTECT

YOUR FITNESS EQUIPMENT
WITH AN EXTENDED SERVICE PLAN

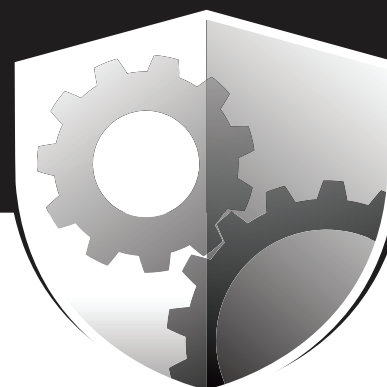

Your new fitness equipment is not an ordinary purchase; it is an investment in your health and well being for years to come.

As the leading provider of manufacturer's extended service plans, ICON strives to protect your equipment and your future.

Please review the following service plans and find one that best fits your needs.

PREVENTIVE MAINTENANCE SERVICE PLANS

| Equipment Price | 3-Year Plan | 5-Year Plan |
|---|-------------|-------------|
| \$0.00 to \$1000.00 | \$199.99 | \$289.99 |
| \$1001.00 to \$1500.00 | \$259.99 | \$379.99 |
| \$1501.00 to \$2500.00 | \$339.99 | \$489.99 |
| (Bikes/Systems Only) \$0.00 to \$2500.00 | \$139.99 | NA |

Features:

- Includes an annual preventive maintenance and performance check at your convenience
- Unlimited in-home repairs; no shipping required
- Covers parts and labor on all manufacturer's defects, as well as wear and tear on parts
- Up to 5 years of coverage available

STANDARD SERVICE PLANS

| Equipment Price | 1-Year Plan | 2-Year Plan | 3-Year Plan |
|------------------------|-------------|-------------|-------------|
| \$0.00 to \$300.00 | \$29.99 | \$39.99 | \$59.99 |
| \$301.00 to \$1000.00 | \$89.99 | \$119.99 | \$149.99 |
| \$1001.00 to \$2000.00 | \$109.99 | \$139.99 | \$179.99 |
| \$2001.00 to \$3000.00 | \$179.99 | \$209.99 | \$239.99 |

Features:

- Unlimited in-home repairs; no shipping required
- Covers parts and labor on all manufacturer's defects, as well as wear and tear parts
- Up to 3 years of coverage available

To protect your fitness equipment today, please
call Customer Care at **1-800-677-3838.**
Or, visit us online at **www.utserv.com.**



BEFORE YOU BEGIN

Thank you for selecting the new PROFORM® 490 SPX exercise bike. Cycling is an effective exercise for increasing cardiovascular fitness, building endurance, and toning the body. The 490 SPX exercise bike provides a selection of features designed to make your workouts at home more effective and enjoyable.

For your benefit, read this manual carefully before you use the exercise bike. If you have questions after

reading this manual, please see the front cover of this manual. To help us assist you, note the product model number and serial number before contacting us. The model number and the location of the serial number decal are shown on the front cover of this manual.

Before reading further, please familiarize yourself with the parts that are labeled in the drawing below.

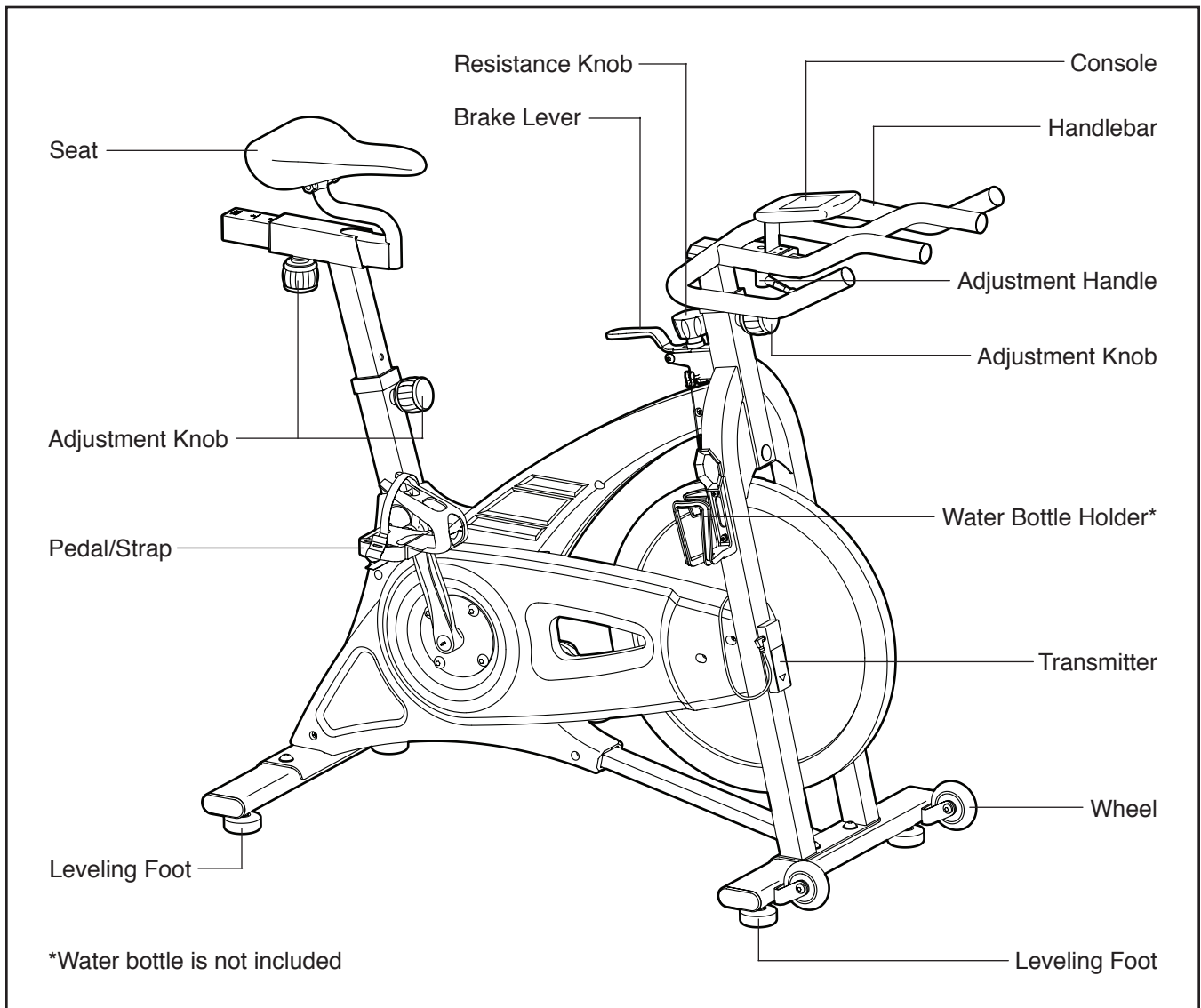

ASSEMBLY

- To hire an authorized service technician to assemble this product, call 1-800-445-2480.
- Assembly requires two persons.
- Place all parts in a cleared area and remove the packing materials. Do not dispose of the packing materials until you finish all assembly steps.
- Left parts are marked “L” or “Left” and right parts are marked “R” or “Right.”

- In addition to the included tool(s), assembly requires the following tools:

one Phillips screwdriver 

one adjustable wrench 

one tape measure 

Assembly may be easier if you have a set of wrenches. To avoid damaging parts, do not use power tools.

1. Go to www.proformservice.com/registration on your computer and register your product.

Registration provides the following benefits:

- activates your product manufacturer’s warranty
- saves you time if you ever need to contact Customer Care
- allows us to notify you of upgrades and offers

Note: If you do not have Internet access, call CUSTOMER CARE (see the front cover of this manual) to register your product.

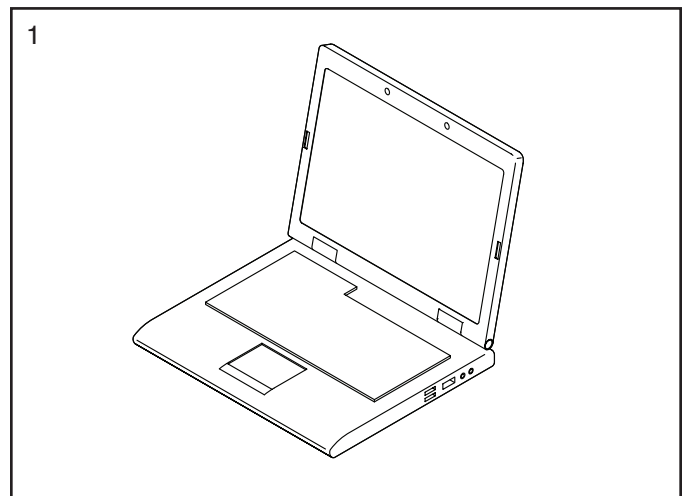

2. Remove the two screws, the two washers, and the shipping bracket (not shown) from the rear of the Frame (1). Discard the screws, washers, and shipping bracket.

Identify the Rear Stabilizer (7), which does not have wheels.

Attach the Rear Stabilizer (7) to the Frame (1) with two M10 x 25mm Screws (34) and two Stabilizer Washers (33).

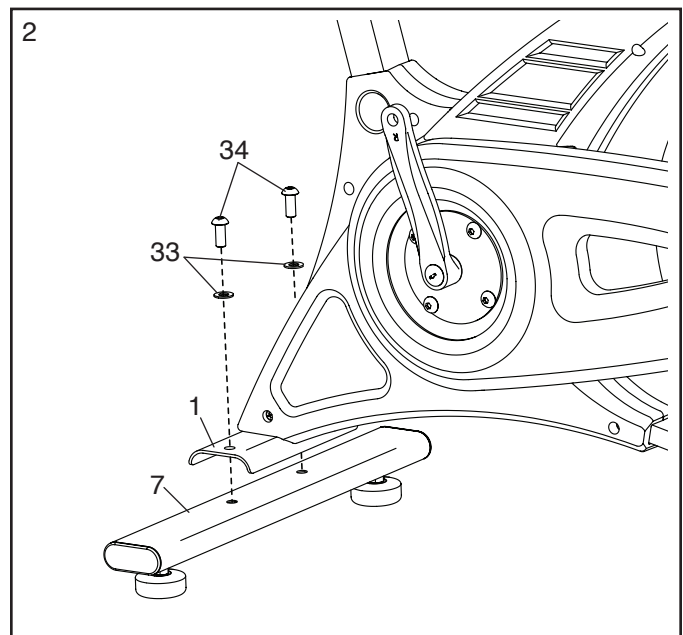

3. Remove the two screws, the two washers, and the shipping bracket (not shown) from the front of the Frame (1). Discard the screws, washers, and shipping bracket.

Attach the Front Stabilizer (8) to the Frame (1) with two M10 x 25mm Screws (34) and two Stabilizer Washers (33).

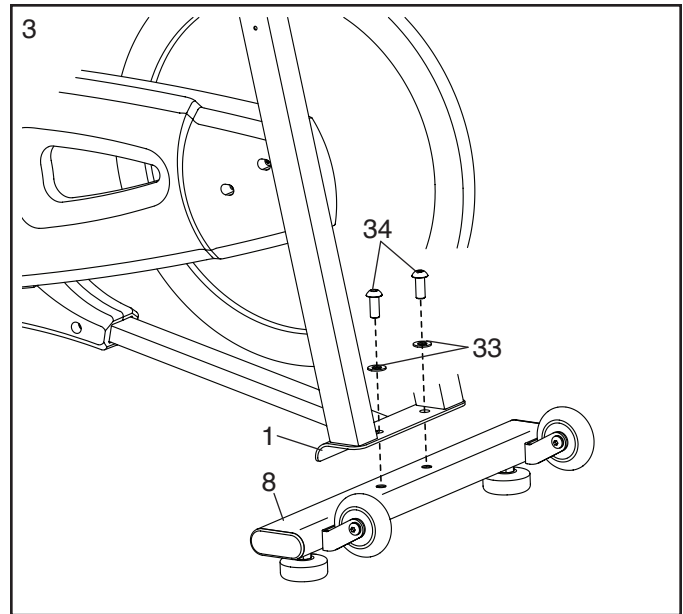

4. Identify the Right Pedal (35).

Using an adjustable wrench, **firmly tighten** the Right Pedal (35) **clockwise** into the Right Crank Arm (26).

Tighten the Left Pedal (not shown) **counter-clockwise** into the Left Crank Arm (not shown).

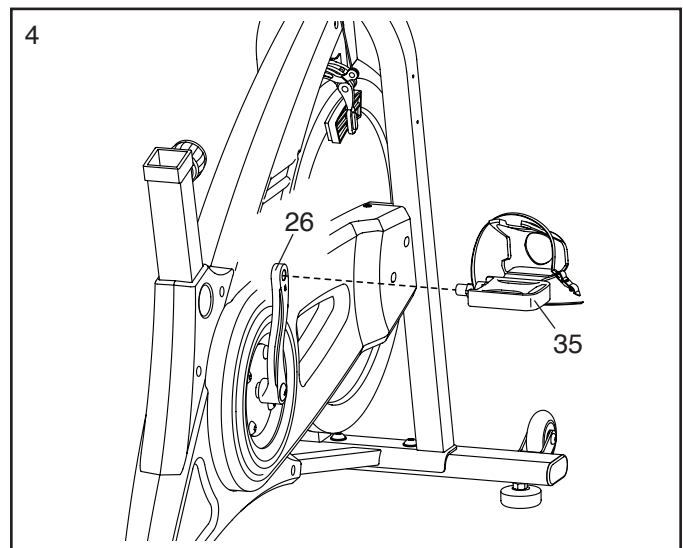

5. Orient the Handlebar Post (4) as shown.

Locate the Adjustment Knob (23) on the front of the Frame (1). Loosen the Adjustment Knob and pull it outward. Then, insert the Handlebar Post (4) into the Frame.

Move the Handlebar Post (4) upward or downward to the desired position, release the Adjustment Knob (23) into an adjustment hole in the Handlebar Post, and then tighten the Adjustment Knob. **Make sure that the Adjustment Knob is firmly engaged in an adjustment hole.**

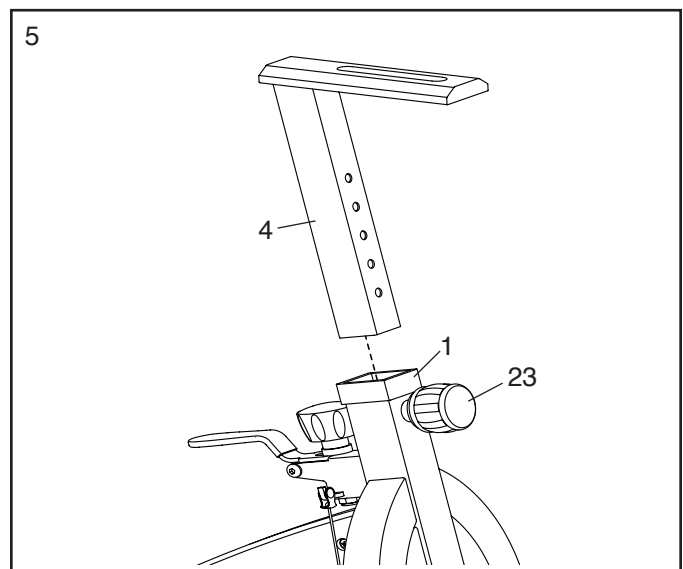

6. Attach the Handlebar (5) to the Handlebar Post (4) with the Handle (31) and the Handle Washer (32).

Note: The Handle (31) functions like a ratchet. Turn the Handle clockwise, pull the Handle outward, turn the Handle counterclockwise, push the Handle inward, and then turn the Handle clockwise again. Repeat this process until the Handle is tight.

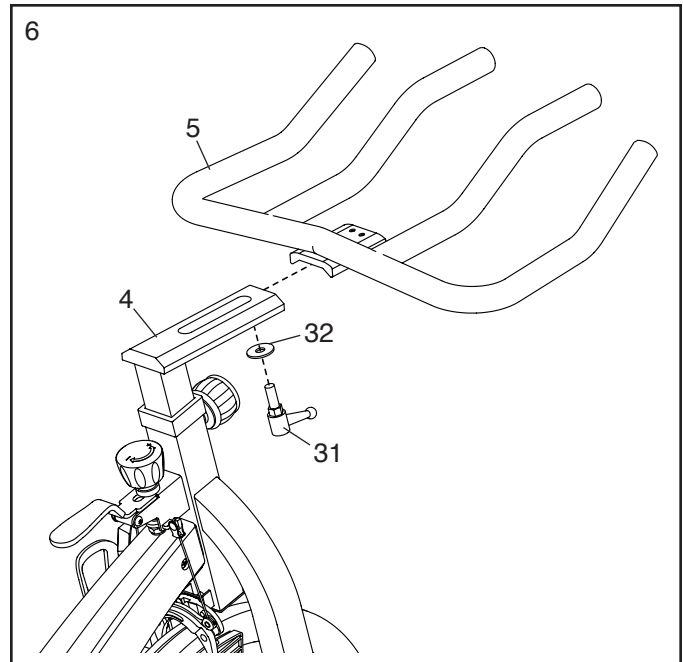

7. Orient the Seat Post (2) as shown.

Locate the Adjustment Knob (23) on the rear of the Frame (1). Loosen the Adjustment Knob and pull it outward. Then, insert the Seat Post (2) into the Frame.

Move the Seat Post (2) upward or downward to the desired position, release the Adjustment Knob (23) into an adjustment hole in the Seat Post, and then tighten the Adjustment Knob.

Make sure that the Adjustment Knob is firmly engaged in an adjustment hole.

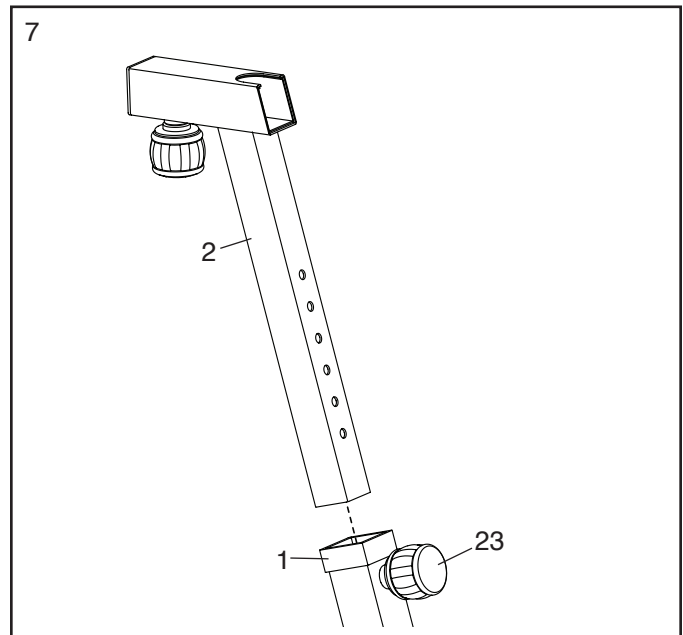

8. Orient the Seat (22) and the Seat Carriage (3) as shown.

Attach the Seat (22) to the Seat Carriage (3) with two M8 Hex Nuts (71). **Make sure that the nose of the Seat is pointing straight ahead before you tighten the Hex Nuts.**

Locate the Adjustment Knob (23) on the Seat Post (2). Loosen the Adjustment Knob and pull it outward. Then, insert the Seat Carriage (3) into the Seat Post.

Slide the Seat Carriage (3) to the desired position, release the Adjustment Knob (23) into one of the adjustment holes in the Seat Carriage, and then tighten the Adjustment Knob. **Make sure that the Adjustment Knob is firmly engaged in an adjustment hole.**

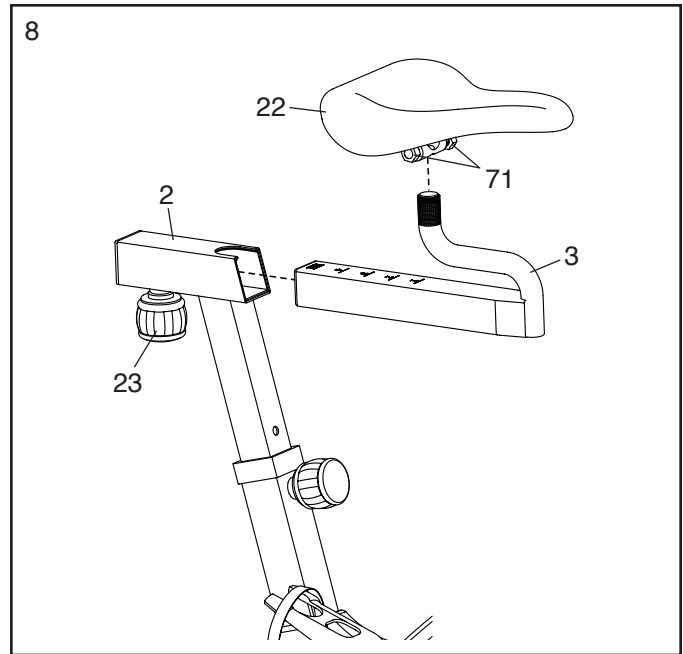

9. Attach the Water Bottle Holder (74) to the Frame (1) with two M5 x 12mm Screws (63) and two M5 Washers (60).

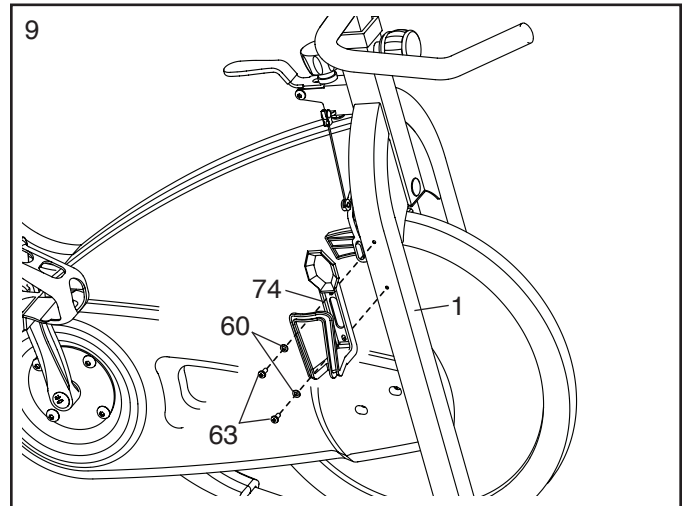

10. Attach the Console Bracket (78) to the Handlebar (5) with two Bracket Screws (76).

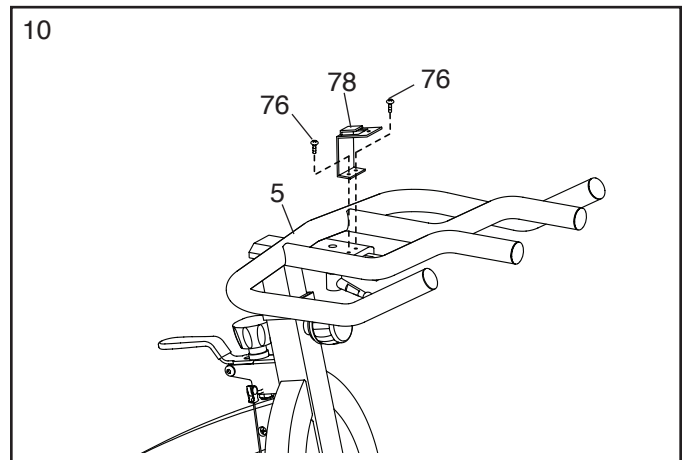

11. The Console (75) requires two AAA batteries (not included); alkaline batteries are recommended. **IMPORTANT: If the Console has been exposed to cold temperatures, allow it to warm to room temperature before you insert batteries. Otherwise, you may damage the console display or other electronic components.**

Remove the battery cover from the back of the Console (75), and insert batteries into the battery compartment. **Make sure that the batteries are oriented as shown by the diagrams inside the battery compartment.** Then, reattach the battery cover.

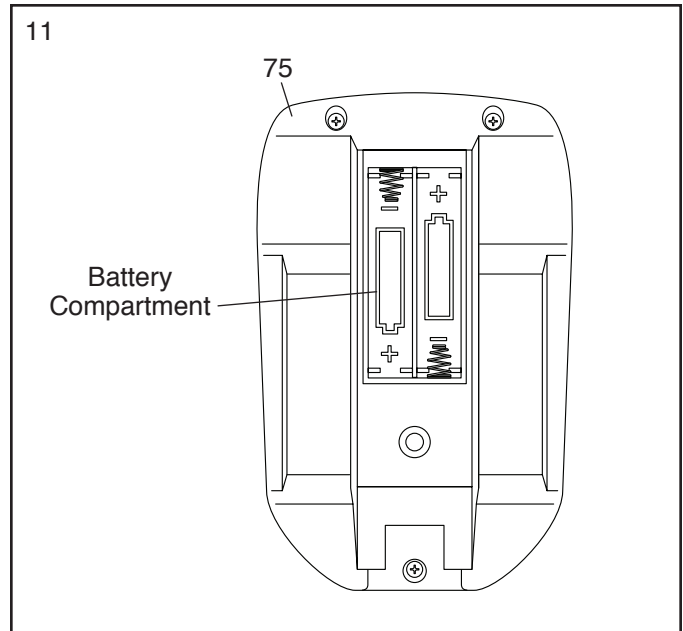

12. Attach the Console (75) to the Console Bracket (78) with a Console Screw (77).

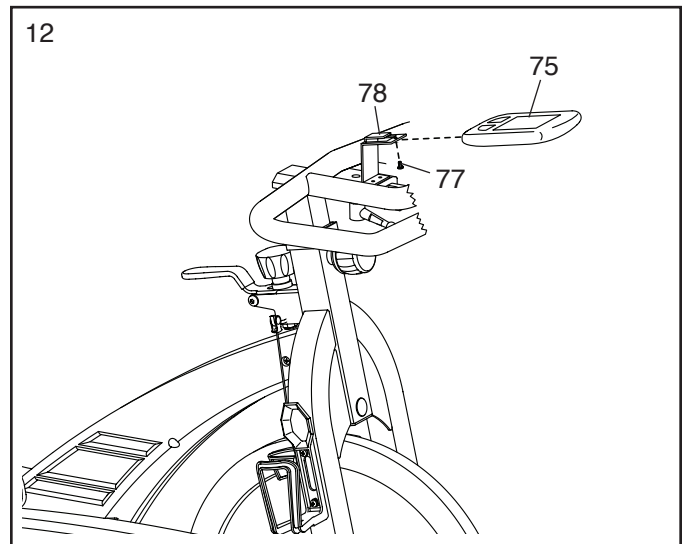

13. The Transmitter (81) requires two AAA batteries (not included); alkaline batteries are recommended.

Remove the battery cover from the front of the Transmitter (81), and insert batteries into the battery compartment. **Make sure that the batteries are oriented as shown by the diagrams inside the battery compartment.** Then, reattach the battery cover.

IMPORTANT: From the top of the stabilizer, measure 11 1/2 in. (29 cm) along the Frame (1) as shown. The Transmitter (81) must be attached in this location.

Remove the adhesive backing from the Hook and Loop Fasteners (79). Press a Fastener onto the Frame (1) in the indicated location.

Orient the Transmitter (81) as shown. Press the other Fastener (79) onto the back of the Transmitter.

Attach the Transmitter (81) to the Frame (1) using the Hook and Loop Fasteners (79).

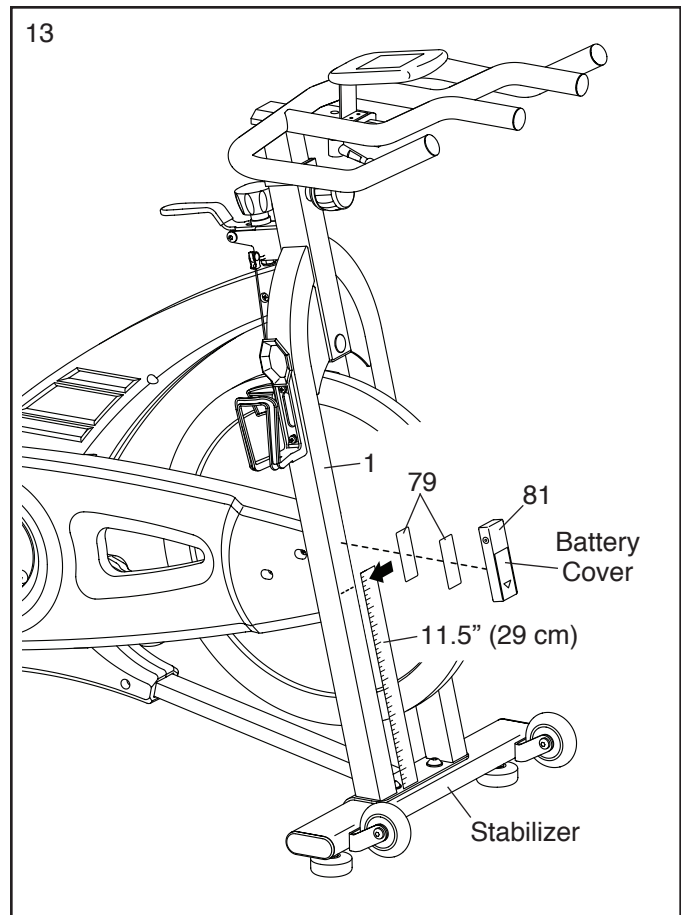

14. Plug the Reed Switch (80) into the Transmitter (81).

Insert the other end of the Reed Switch (80) into the Clamp (82).

Rotate the Flywheel (36) until the Magnet (84) is aligned with the end of the Reed Switch (80).

Move the Reed Switch (80) so that the gap between the Reed Switch and the Magnet (84) is about 1/8 in. (3 mm).

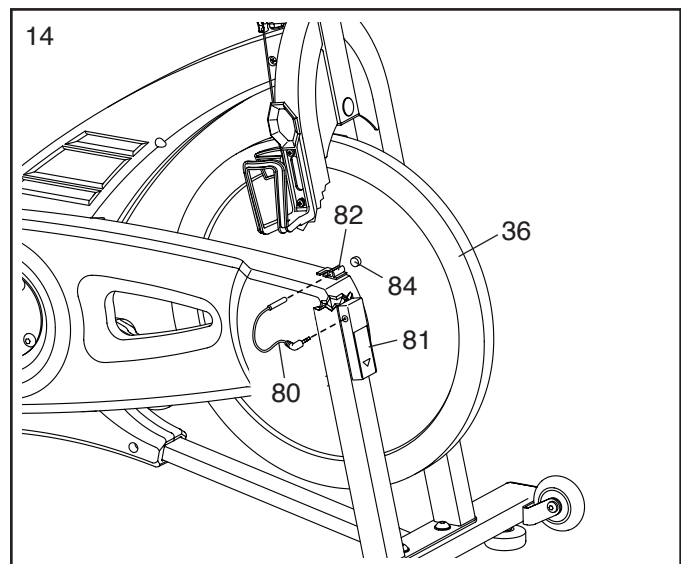

15. **After the exercise bike is assembled, inspect it to make sure that it is assembled correctly and that it functions properly. Make sure that all parts are properly tightened before you use the exercise bike.** Note: Extra parts may be included. Place a mat beneath the exercise bike to protect the floor.

HOW TO USE THE EXERCISE BIKE

HOW TO ADJUST THE ANGLE OF THE SEAT

You can adjust the angle of the seat to the position that is most comfortable. You can also slide the seat forward or backward to increase your comfort or to adjust the distance to the handlebar.

To adjust the seat, see the drawing in assembly step 8 on page 9. Loosen the nuts on the seat clamp a few turns, and then tilt the seat upward or downward or slide the seat forward or backward to the desired position. Then, retighten the nuts.

HOW TO ADJUST THE HORIZONTAL POSITION OF THE SEAT

To adjust the horizontal position of the seat, first loosen the adjustment knob and pull it downward. Then, move the seat forward or backward, release the adjustment knob into an adjustment hole in the seat carriage, and firmly tighten the adjustment knob. **Make sure that the adjustment knob is engaged in an adjustment hole.**

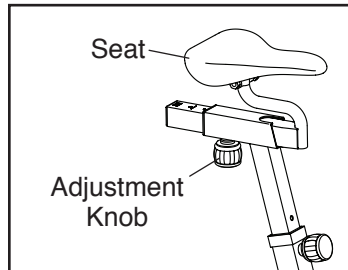

HOW TO ADJUST THE SEAT POST

For effective exercise, the seat should be at the proper height. As you pedal, there should be a slight bend in your knees when the pedals are in the lowest position.

To adjust the height of the seat post, first loosen the adjustment knob and pull it outward. Then, move the seat post upward or downward, release the adjustment knob into an adjustment hole in the seat post, and firmly tighten the adjustment knob. **Make sure that the adjustment knob is engaged in an adjustment hole.**

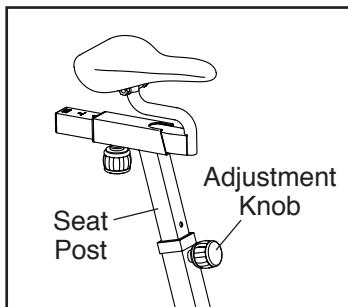

HOW TO ADJUST THE HORIZONTAL POSITION OF THE HANDLEBAR

To adjust the horizontal position of the handlebar, loosen the handle, move the handlebar forward or backward to the desired position, and then tighten the handle.

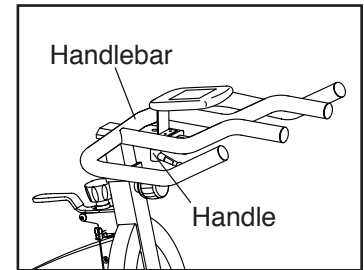

Note: The handle functions like a ratchet. To loosen the handle, turn the handle counterclockwise, pull the handle outward, turn the handle clockwise, push the handle inward, and then turn the handle counterclockwise again. Reverse this process to tighten the handle.

HOW TO ADJUST THE HANDLEBAR POST

To adjust the height of the handlebar post, first loosen the adjustment knob and pull it outward. Then, move the handlebar post upward or downward, release the adjustment knob into an adjustment hole in the handlebar post, and firmly tighten the adjustment knob.

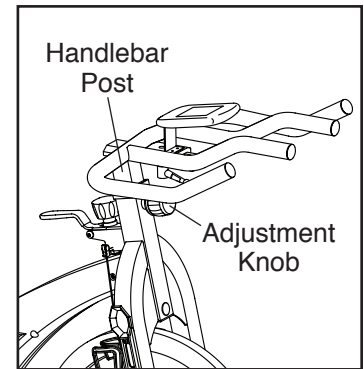

Make sure that the adjustment knob is engaged in an adjustment hole.

HOW TO ADJUST THE PEDAL STRAPS

To tighten the pedal straps (see the drawing on page 5), simply pull the ends of the pedal straps. To loosen the pedal straps, press and hold the tabs on the buckles, adjust the pedal straps to the desired position, and then release the tabs.

HOW TO ADJUST THE PEDALING RESISTANCE

To increase the resistance of the pedals, turn the resistance knob clockwise; to decrease the resistance, turn the resistance knob counterclockwise. **To stop the flywheel, push the brake lever downward.**

The flywheel should quickly come to a complete stop.

IMPORTANT: When the exercise bike is not in use, tighten the resistance knob completely.

HOW TO LEVEL THE EXERCISE BIKE

If the exercise bike rocks slightly on your floor during use, turn one or both of the leveling feet on the front or rear stabilizer (see the drawing on page 5) until the rocking motion is eliminated.

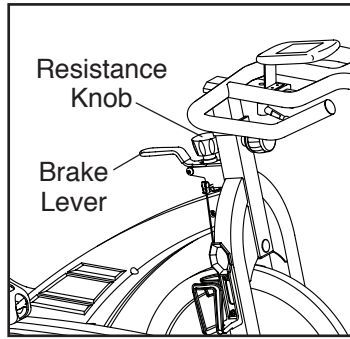

HOW TO MAINTAIN THE EXERCISE BIKE

Inspect and tighten all parts of the exercise bike regularly. Replace any worn parts immediately.

To clean the exercise bike, use a damp cloth and a small amount of mild detergent. **IMPORTANT: To avoid damage to the console, keep liquids away from the console and keep the console out of direct sunlight.**

HOW TO ADJUST THE REED SWITCH

If the console does not display correct feedback, the reed switch should be adjusted. To adjust the reed switch, see the drawing in assembly step 14 on page 11.

Rotate the flywheel until the magnet is aligned with the reed switch. Slide the reed switch slightly toward or away from the magnet. Then, rotate the flywheel for a moment. Repeat these actions until the console displays correct feedback.

CONSOLE DIAGRAM

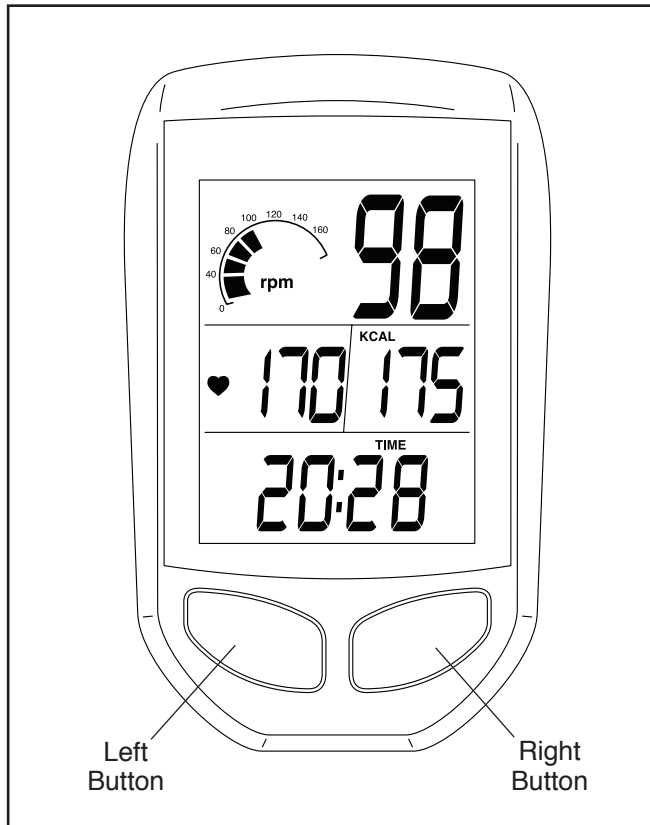

FEATURES OF THE CONSOLE

The console offers a selection of features designed to provide instant exercise feedback and make your workouts more effective.

The console features a heart rate alarm that helps you keep your heart rate within your selected target heart rate zone while you exercise. Note: To use this feature, you must wear an optional heart rate monitor (see page 18).

The console also allows you to personalize settings, select a system of measurement, and enter user information before you begin exercising.

To personalize console settings, see the instructions at the right. **To set the clock**, see page 16. **To use the console**, see page 16. **To use the heart rate alarm**, see page 18.

Before using the console, make sure that batteries are installed in the console and the transmitter (see assembly step 11 on page 10 and assembly step 13 on page 11). If there is a sheet of plastic on the display, remove the plastic.

HOW TO PERSONALIZE CONSOLE SETTINGS

1. Turn on the console.

Press any button to turn on the console.

2. Enter the setup mode.

First, press the Left button repeatedly until the word SPEED appears in the lower display.

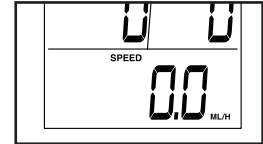

Then, press and hold the Right button for several seconds to enter the setup mode.

Note: The console will exit the setup mode automatically if several seconds pass and no buttons are pressed.

3. Set a time goal if desired.

When you enter the setup mode, the minutes place in the lower display will flash.



To set a time goal for your workout, press the Right button repeatedly to select the desired number of minutes. To select a time goal quickly, press and hold down the Right button.



Note: You can set a time goal between 1 and 99 minutes.

Note: If you set a time goal, the lower display will count down the time remaining in your workout instead of the elapsed time (see step 3 of HOW TO USE THE CONSOLE on page 16).

Press the Left button to advance to the next setting.

4. Define the target heart rate zone if desired.

The maximum heart rate will flash in the middle left display.

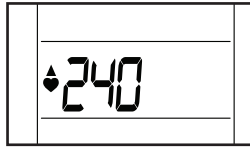

To set the maximum heart rate, press the Right button repeatedly to select the desired heart rate. To select a heart rate quickly, press and hold down the Right button.

Next, press the Left button. The minimum heart rate will flash in the middle left display.

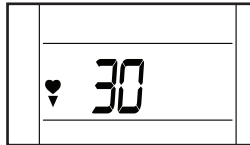

To set the minimum heart rate, press the Right button repeatedly to select the desired heart rate. To select a heart rate quickly, press and hold down the Right button.

Note: You must define a target heart rate zone to use the heart rate alarm (see HOW TO USE THE HEART RATE ALARM on page 18).

To determine your target heart rate zone, see EXERCISE INTENSITY on page 20.

Press the Left button to advance to the next setting.

5. Enter your gender if desired.

A gender symbol will flash in the lower display.

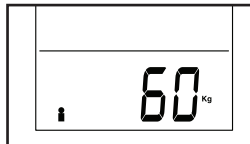

Press the Right button repeatedly to select the symbol that represents your gender.

Press the Left button to advance to the next setting.

6. Select a unit of measurement if desired.

The console can display speed, distance, and weight in standard or metric measurements.

The letters Lb (standard) or Kg (metric) will flash in the lower display to show which unit of measurement is selected.

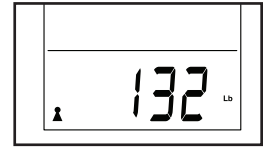

Press the Right button repeatedly to select the desired unit of measurement.

Press the Left button to advance to the next setting.

7. Enter your weight if desired.

A weight setting will flash in the lower display.

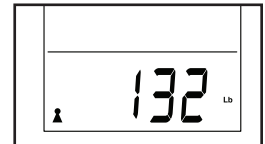

Press the Right button repeatedly to select your weight. To select your weight quickly, press and hold down the Right button.

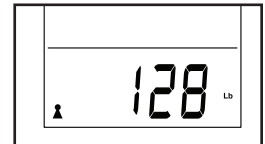

Note: You can select a weight setting between 44 and 396 pounds or between 20 and 180 kilograms. **The exercise bike should not be used by persons weighing more than 275 pounds or 125 kilograms.**

8. Exit the setup mode at any time.

The console will exit the setup mode automatically if several seconds pass and no buttons are pressed.

Note: To advance again through the settings described in steps 3 to 7, press the Left button repeatedly.

HOW TO SET THE CLOCK

1. Turn on the console.

Press any button to turn on the console.

2. Enter the clock mode.

First, press the Left button repeatedly until the clock symbol appears in the lower display.

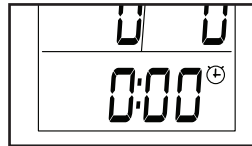

Then, press and hold the Right button for several seconds to enter the clock mode.

Note: The console will exit the clock mode automatically if several seconds pass and no buttons are pressed.

3. Change the time notation if desired.

The time notation will flash in the middle right display.

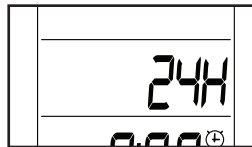

Press the Right button repeatedly to select the desired time notation. Select 12H for a 12-hour clock. Select 24H for a 24-hour clock.

4. Set the time.

Press the Left button to select the hour setting. The hour setting will flash in the lower display.



Press the Right button repeatedly to select the desired hour setting. **Make sure to select the correct am or pm setting when you select the hour setting.**

Press the Left button to select the minute setting. The minute setting will flash in the lower display.

Press the Right button repeatedly to select the desired minute setting.

5. Exit the clock mode at any time.

The console will exit the clock mode automatically if several seconds pass and no buttons are pressed.

HOW TO USE THE CONSOLE

1. Turn on the console.

Press any button to turn on the console.

2. Wear an optional heart rate monitor if desired.

To display your heart rate (see step 3) or use the heart rate alarm (see HOW TO USE THE HEART RATE ALARM on page 18), you must wear an optional heart rate monitor (see page 18).

3. Follow your progress with the displays.

The upper left display—

As you pedal, the rpm meter in this display indicates your approximate pedaling speed in revolutions per minute (rpm) in a range from 0 rpm to 200 rpm. Bars will appear or disappear in increments as you change your pedaling speed.

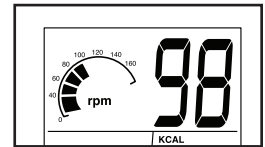

The upper right display—

This display shows your pedaling speed in revolutions per minute (rpm) in a range from 0 rpm to 240 rpm.

Note: When you stop pedaling, this display shows the average pedaling speed (AVG rpm) for your workout.

The middle left display—

This display shows your heart rate (heart symbol) in beats per minute (bpm) in a range from 0 to 240 bpm when you wear an optional heart rate monitor (see page 18).

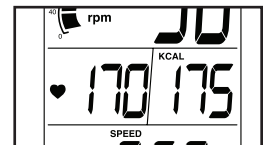

The middle right display—

This display shows the approximate number of calories (KCAL) you have burned.

The lower display—This display can show the following workout information:

Speed (SPEED)—This display shows your pedaling speed in miles per hour (ML/H) or kilometers per hour (KM/H).



Note: When you stop pedaling, this display shows the average pedaling speed (AVG SPEED) for your workout.

Distance (DIST)—This display shows the distance you have pedaled in miles (ML) or kilometers (KM).



Time (TIME)—This display shows the elapsed time in a range from 0 minutes to 99 minutes.



Note: If you set a time goal (see step 4), this display shows the time remaining in your workout instead of the elapsed time.

Clock (Clock symbol)—This display shows the time of day using a 12-hour clock or a 24-hour clock.



Press the Left button repeatedly until the lower display shows the workout information you are interested in viewing.

To reset the displays, press the Left button repeatedly until the word TIME appears in the lower display. Then, press and hold the Right button until zeros appear in the displays.

To turn on the console backlight for a few seconds, press the Right button once at any time.

Note: The console can display speed and distance in either miles or kilometers. The letters ML/H or KM/H will appear in the display to show which unit of measurement is selected. To change the unit of measurement, see step 6 on page 15.

4. Set a time goal, if desired.

To set a time goal, see step 3 on page 14.

To clear the time goal, press the Left button repeatedly until the word TIME appears in the lower display. Then, press and hold the Right button until zeros appear in the lower display.

Note: If you set a time goal, the lower display will count down the time remaining in your workout instead of the elapsed time.

When you reach your goal, a tone will sound for several seconds. Then, the console will begin to count the elapsed time.

5. Measure your heart rate if desired.

To display your heart rate, you must wear an optional heart rate monitor (see page 18).

When your heart rate is detected, the heart symbol will flash and your heart rate will be shown in the middle left display.

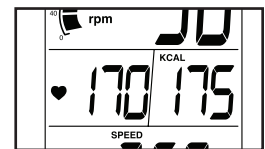

6. When you are finished exercising, the console will turn off automatically.

The console has an auto-off feature. If the pedals do not move and the buttons are not pressed for a few minutes, the power will turn off automatically to save the batteries.

HOW TO USE THE HEART RATE ALARM

The heart rate alarm will alert you when your heart rate is below or above a defined target heart rate zone.

IMPORTANT: You must wear an optional heart rate monitor to use the heart rate alarm (see THE OPTIONAL CHEST HEART RATE MONITOR at the right).

To use the heart rate alarm, first see step 4 on page 15 and define a target heart rate zone.

As you pedal, the console will regularly compare your heart rate to the target heart rate zone and will indicate if your heart rate is too far below or above the target heart rate zone.

When a downward-pointing arrow flashes in the middle left display, increase your pedaling speed.

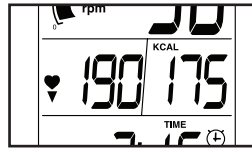

When an upward-pointing arrow flashes in the middle left display, decrease your pedaling speed.

IMPORTANT: The heart rate alarm is intended only to provide motivation. Make sure to pedal at a speed that is comfortable for you.

THE OPTIONAL CHEST HEART RATE MONITOR

Whether your goal is to burn fat or to strengthen your cardiovascular system, the key to achieving the best results is to maintain the proper heart rate during your workouts. The optional chest heart rate monitor will enable you to continuously monitor your heart rate while you exercise, helping you to reach your personal fitness goals. **To purchase a chest heart rate monitor, please see the front cover of this manual.**

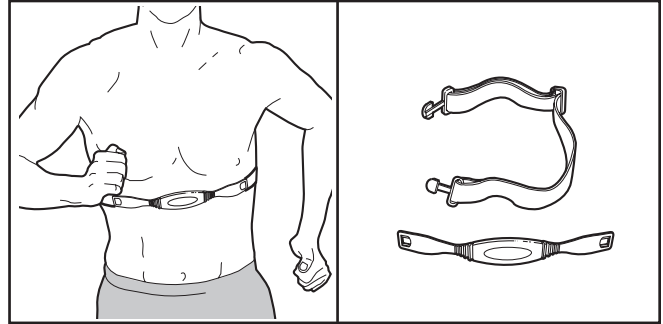

FCC INFORMATION

This equipment has been tested and found to comply with the limits for a Class B digital device, pursuant to part 15 of the FCC Rules. These limits are designed to provide reasonable protection against harmful interference in a residential installation. This equipment generates, uses, and can radiate radio frequency energy and, if not installed and used in accordance with the instructions, may cause harmful interference to radio communications. However, there is no guarantee that interference will not occur in a particular installation. If this equipment does cause harmful interference to radio or television reception, which can be determined by turning the equipment off and on, try to correct the interference by one or more of the following measures:

- Reorient or relocate the receiving antenna.
- Increase the separation between the equipment and the receiver.
- Connect the equipment into an outlet on a circuit different from that to which the receiver is connected.
- Consult the dealer or an experienced radio/TV technician for help.

FCC CAUTION: To assure continued compliance, use only shielded interface cables when connecting to computer or peripheral devices. Changes or modifications not expressly approved by the party responsible for compliance could void the user's authority to operate this equipment.

EXERCISE GUIDELINES

⚠️ WARNING: Before beginning this or any exercise program, consult your physician. This is especially important for persons over age 35 or persons with pre-existing health problems.

The heart rate monitor is not a medical device. Various factors may affect the accuracy of heart rate readings. The heart rate monitor is intended only as an exercise aid in determining heart rate trends in general.

These guidelines will help you to plan your exercise program. For detailed exercise information, obtain a reputable book or consult your physician. Remember, proper nutrition and adequate rest are essential for successful results.

EXERCISE INTENSITY

Whether your goal is to burn fat or to strengthen your cardiovascular system, exercising at the proper intensity is the key to achieving results. You can use your heart rate as a guide to find the proper intensity level. The chart below shows recommended heart rates for fat burning and aerobic exercise.

| | | | | | | | |
|-------|-----|-----|-----|-----|-----|-----|----|
| 165 | 155 | 145 | 140 | 130 | 125 | 115 | ❤️ |
| 145 | 138 | 130 | 125 | 118 | 110 | 103 | ❤️ |
| 125 | 120 | 115 | 110 | 105 | 95 | 90 | ❤️ |
| <hr/> | | | | | | | |
| 20 | 30 | 40 | 50 | 60 | 70 | 80 | |

To find the proper intensity level, find your age at the bottom of the chart (ages are rounded off to the nearest ten years). The three numbers listed above your age define your “training zone.” The lowest number is the heart rate for fat burning, the middle number is the heart rate for maximum fat burning, and the highest number is the heart rate for aerobic exercise.

Burning Fat—To burn fat effectively, you must exercise at a low intensity level for a sustained period of time. During the first few minutes of exercise, your body uses carbohydrate calories for energy. Only after the first few minutes of exercise does your body begin to use stored fat calories for energy. If your goal is to burn fat, adjust the intensity of your exercise until your heart rate is near the lowest number in your training zone. For maximum fat burning, exercise with your heart rate near the middle number in your training zone.

Aerobic Exercise—If your goal is to strengthen your cardiovascular system, you must perform aerobic exercise, which is activity that requires large amounts of oxygen for prolonged periods of time. For aerobic exercise, adjust the intensity of your exercise until your heart rate is near the highest number in your training zone.

WORKOUT GUIDELINES

Warming Up—Start with 5 to 10 minutes of stretching and light exercise. A warm-up increases your body temperature, heart rate, and circulation in preparation for exercise.

Training Zone Exercise—Exercise for 20 to 30 minutes with your heart rate in your training zone. (During the first few weeks of your exercise program, do not keep your heart rate in your training zone for longer than 20 minutes.) Breathe regularly and deeply as you exercise; never hold your breath.

Cooling Down—Finish with 5 to 10 minutes of stretching. Stretching increases the flexibility of your muscles and helps to prevent post-exercise problems.

EXERCISE FREQUENCY

To maintain or improve your condition, complete three workouts each week, with at least one day of rest between workouts. After a few months of regular exercise, you may complete up to five workouts each week, if desired. Remember, the key to success is to make exercise a regular and enjoyable part of your everyday life.

SUGGESTED STRETCHES

The correct form for several basic stretches is shown at the right. Move slowly as you stretch; never bounce.

1. Toe Touch Stretch

Stand with your knees bent slightly and slowly bend forward from your hips. Allow your back and shoulders to relax as you reach down toward your toes as far as possible. Hold for 15 counts, then relax. Repeat 3 times. Stretches: Hamstrings, back of knees and back.

2. Hamstring Stretch

Sit with one leg extended. Bring the sole of the opposite foot toward you and rest it against the inner thigh of your extended leg. Reach toward your toes as far as possible. Hold for 15 counts, then relax. Repeat 3 times for each leg. Stretches: Hamstrings, lower back and groin.

3. Calf/Achilles Stretch

With one leg in front of the other, reach forward and place your hands against a wall. Keep your back leg straight and your back foot flat on the floor. Bend your front leg, lean forward and move your hips toward the wall. Hold for 15 counts, then relax. Repeat 3 times for each leg. To cause further stretching of the achilles tendons, bend your back leg as well. Stretches: Calves, achilles tendons and ankles.

4. Quadriceps Stretch

With one hand against a wall for balance, reach back and grasp one foot with your other hand. Bring your heel as close to your buttocks as possible. Hold for 15 counts, then relax. Repeat 3 times for each leg. Stretches: Quadriceps and hip muscles.

5. Inner Thigh Stretch

Sit with the soles of your feet together and your knees outward. Pull your feet toward your groin area as far as possible. Hold for 15 counts, then relax. Repeat 3 times. Stretches: Quadriceps and hip muscles.

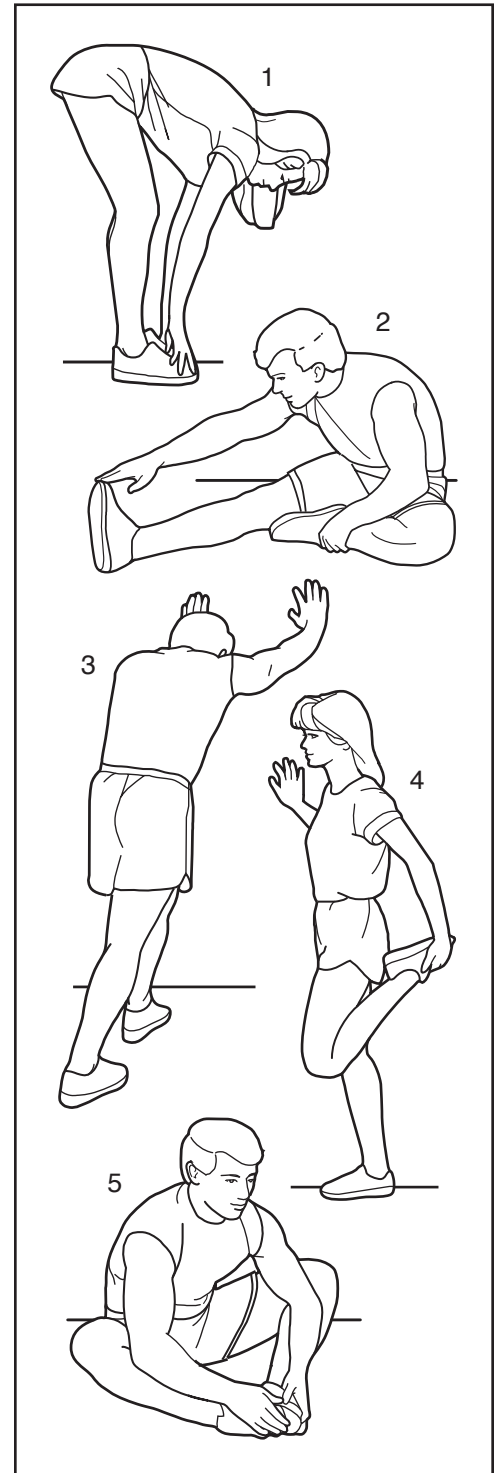

PART LIST

Model No. PFEX03910.2 R0113A

| Key No. | Qty. | Description | Key No. | Qty. | Description |
|---------|------|------------------------|---------|------|------------------------|
| 1 | 1 | Frame | 44 | 2 | Flywheel Bearing |
| 2 | 1 | Seat Post | 45 | 2 | Crank Bearing |
| 3 | 1 | Seat Carriage | 46 | 4 | Wheel Bearing |
| 4 | 1 | Handlebar Post | 47 | 1 | Flywheel Snap Ring |
| 5 | 1 | Handlebar | 48 | 2 | Crank Snap Ring |
| 6 | 1 | Tension Bracket | 49 | 1 | T1 Nut |
| 7 | 1 | Rear Stabilizer | 50 | 15 | Self-tapping Screw |
| 8 | 1 | Front Stabilizer | 51 | 1 | Flange Nut |
| 9 | 1 | Brake Lever | 52 | 1 | Acorn Nut |
| 10 | 1 | Felt Washer | 53 | 2 | Crank Nut |
| 11 | 1 | Resistance Knob | 54 | 1 | Caliper Brake |
| 12 | 1 | Right Cover | 55 | 3 | M12 Thin Hex Nut |
| 13 | 1 | Left Cover | 56 | 1 | M6 Flange Nut |
| 14 | 1 | Right Shield | 57 | 1 | Tension Nut |
| 15 | 1 | Left Shield | 58 | 1 | M10 Locknut |
| 16 | 4 | Leveling Foot | 59 | 2 | M5 x 10mm Screw |
| 17 | 1 | Handlebar Post Bushing | 60 | 4 | M5 Washer |
| 18 | 4 | Stabilizer Cap | 61 | 4 | M8 Hex Nut |
| 19 | 3 | Post Cap | 62 | 2 | Brake Cable |
| 20 | 1 | Shield Cover | 63 | 4 | M5 x 12mm Screw |
| 21 | 2 | Wheel | 64 | 2 | Seat Post Bushing |
| 22 | 1 | Seat | 65 | 4 | M10 x 16mm Bolt |
| 23 | 3 | Adjustment Knob | 66 | 1 | Left Crank Arm |
| 24 | 1 | Brake Cap | 67 | 1 | Left Pedal/Strap |
| 25 | 1 | Frame Cap | 68 | 3 | M6 x 30mm Bolt Set |
| 26 | 1 | Right Crank Arm | 69 | 1 | M6 x 40mm Bolt |
| 27 | 2 | Crank Cap | 70 | 2 | Brake Pad Mount |
| 28 | 1 | Drive Belt | 71 | 2 | M8 Hex Nut |
| 29 | 1 | Tension Spring | 72 | 1 | Flat Washer |
| 30 | 1 | Crank | 73 | 1 | M10 x 25mm Bolt |
| 31 | 1 | Handle | 74 | 1 | Water Bottle Holder |
| 32 | 1 | Handle Washer | 75 | 1 | Console |
| 33 | 4 | Stabilizer Washer | 76 | 2 | Bracket Screw |
| 34 | 4 | M10 x 25mm Screw | 77 | 1 | Console Screw |
| 35 | 1 | Right Pedal/Strap | 78 | 1 | Console Bracket |
| 36 | 1 | Flywheel | 79 | 1 | Hook and Loop Fastener |
| 37 | 1 | Flywheel Axle | 80 | 1 | Reed Switch |
| 38 | 1 | Pulley | 81 | 1 | Transmitter |
| 39 | 1 | Flywheel Sleeve | 82 | 1 | Clamp |
| 40 | 1 | Idler Pulley | 83 | 1 | Clamp Screw |
| 41 | 2 | Brake Pad | 84 | 1 | Magnet |
| 42 | 1 | Brake Clamp | * | — | Assembly Tool |
| 43 | 1 | Knob Washer | * | — | User's Manual |

Note: Specifications are subject to change without notice. For information about ordering replacement parts, see the back cover of this manual. *These parts are not illustrated.

EXPLODED DRAWING

Model No. PFEX03910.2 R0113A

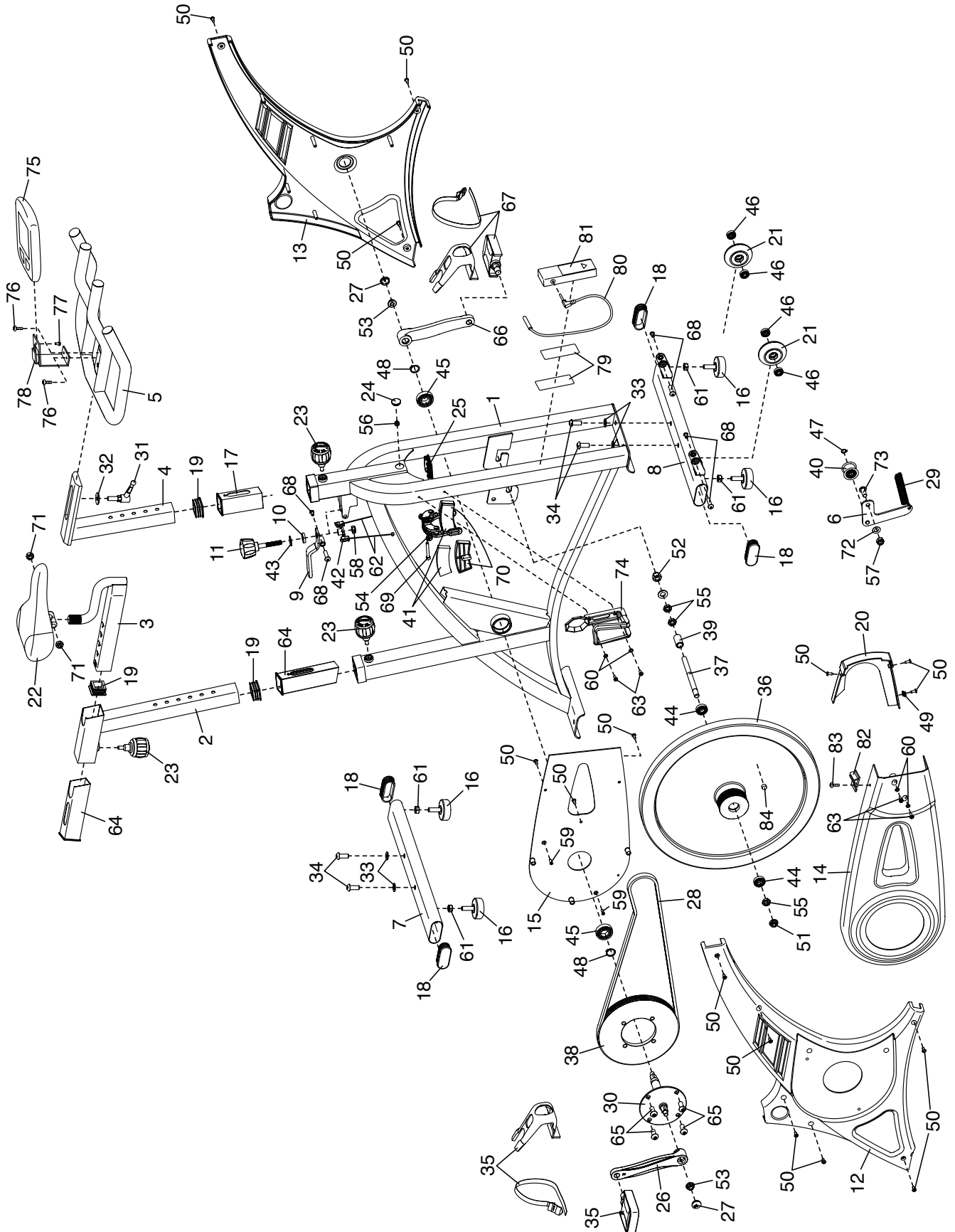

ORDERING REPLACEMENT PARTS

To order replacement parts, please see the front cover of this manual. To help us assist you, be prepared to provide the following information when contacting us:

- the model number and serial number of the product (see the front cover of this manual)
- the name of the product (see the front cover of this manual)
- the key number and description of the replacement part(s) (see the PART LIST and the EXPLODED DRAWING near the end of this manual)

LIMITED WARRANTY

IMPORTANT: To protect your fitness equipment with an extended service plan, see page 4.

ICON Health & Fitness, Inc. (ICON) warrants this product to be free from defects in workmanship and material, under normal use and service conditions. The frame is warranted for five (5) years from the date of purchase. Parts and labor are warranted for one (1) year from the date of purchase.

This warranty extends only to the original purchaser (customer). ICON's obligation under this warranty is limited to repairing or replacing, at ICON's option, the product through one of its authorized service centers. All repairs for which warranty claims are made must be preauthorized by ICON. If the product is shipped to a service center, freight charges to and from the service center will be the customer's responsibility. If replacement parts are shipped while the product is under warranty, the customer will be responsible for a minimal handling charge. For in-home service, the customer will be responsible for a minimal trip charge. This warranty does not extend to freight damage to the product. This warranty will automatically be voided if the product is used as a store display model, if the product is purchased or transported outside the USA, if all instructions in this manual are not followed, if the product is abused or improperly or abnormally used, or if the product is used for commercial or rental purposes. No other warranty beyond that specifically set forth above is authorized by ICON.

ICON is not responsible or liable for indirect, special, or consequential damages arising out of or in connection with the use or performance of the product; damages with respect to any economic loss, loss of property, loss of revenues or profits, loss of enjoyment or use, or costs of removal or installation; or other consequential damages of any kind. Some states do not allow the exclusion or limitation of incidental or consequential damages. Accordingly, the above limitation may not apply to the customer.

The warranty extended hereunder is in lieu of any and all other warranties, and any implied warranties of merchantability or fitness for a particular purpose are limited in their scope and duration to the terms set forth herein. Some states do not allow limitations on how long an implied warranty lasts. Accordingly, the above limitation may not apply to the customer.

This warranty provides specific legal rights; the customer may have other rights that vary from state to state.

ICON Health & Fitness, Inc., 1500 S. 1000 W., Logan, UT 84321-9813