

## ORDERING REPLACEMENT PARTS

To order replacement parts, call our Customer Service Department toll-free at 1-800-999-3756, Monday through Friday, 6 a.m. until 6 p.m. Mountain Time (excluding holidays). To help us assist you, please be prepared to give the following information:

- The MODEL NUMBER of the product (PFEX77572).
- The NAME of the product (PROFORM® 775s).
- The SERIAL NUMBER of the product (see the front cover of this manual).
- The KEY NUMBER and DESCRIPTION of the part(s) (see the PART LIST on page 10 of this manual).

PROFORM® is a registered trademark of ICON Health & Fitness, Inc.

### LIMITED WARRANTY

ICON Health & Fitness, Inc. (ICON), warrants this product to be free from defects in workmanship and material, under normal use and service conditions, for a period of ninety (90) days from the date of purchase. This warranty extends only to the original purchaser. ICON's obligation under this warranty is limited to replacing or repairing, at ICON's option, the product through one of its authorized service centers. All repairs for which warranty claims are made must be pre-authorized by ICON. This warranty does not extend to any product or damage to a product caused by or attributable to freight damage, abuse, misuse, improper or abnormal usage or repairs not provided by an ICON authorized service center, products used for commercial or rental purposes, or products used as store display models. No other warranty beyond that specifically set forth above is authorized by ICON.

ICON is not responsible or liable for indirect, special or consequential damages arising out of or in connection with the use or performance of the product or damages with respect to any economic loss, loss of property, loss of revenues or profits, loss of enjoyment or use, costs of removal, installation or other consequential damages of whatsoever nature. Some states do not allow the exclusion or limitation of incidental or consequential damages. Accordingly, the above limitation may not apply to you.

The warranty extended hereunder is in lieu of any and all other warranties and any implied warranties of merchantability or fitness for a particular purpose is limited in its scope and duration to the terms set forth herein. Some states do not allow limitations on how long an implied warranty lasts. Accordingly, the above limitation may not apply to you.

This warranty gives you specific legal rights. You may also have other rights which vary from state to state.

ICON HEALTH & FITNESS, INC., 1500 S. 1000 W., LOGAN, UT 84321-9813

# PRO-FORM® 775s

SILENT MAGNETIC RESISTANCE

Model No. PFEX77572

Serial No. \_\_\_\_\_

The serial number is found in the location shown below. Write the serial number in the space above.

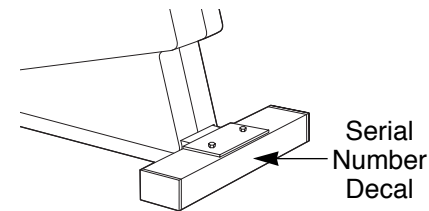

### QUESTIONS?

As a manufacturer, we are committed to providing complete customer satisfaction. If you have questions, or if there are missing or damaged parts, we will guarantee complete satisfaction through direct assistance from our factory.

**TO AVOID UNNECESSARY DELAYS, PLEASE CALL DIRECT TO OUR TOLL-FREE CUSTOMER HOT LINE. The trained technicians on our customer hot line will provide immediate assistance, free of charge to you.**

**CUSTOMER HOT LINE:**  
**1-800-999-3756**  
Mon.-Fri., 6 a.m.-6 p.m. MST

### CAUTION

Read all precautions and instructions in this manual before using this equipment. Save this manual for future reference.



## USER'S MANUAL

# TABLE OF CONTENTS

IMPORTANT PRECAUTIONS	2
BEFORE YOU BEGIN	3
ASSEMBLY	4
HOW TO USE THE PROFORM® 775S	6
MAINTENANCE AND TROUBLE-SHOOTING	8
CONDITIONING GUIDELINES	9
PART LIST	10
EXPLODED DRAWING	11
ORDERING REPLACEMENT PARTS	Back Cover
LIMITED WARRANTY	Back Cover

# EXPLODED DRAWING—Model No. PFEX77572

R0798A

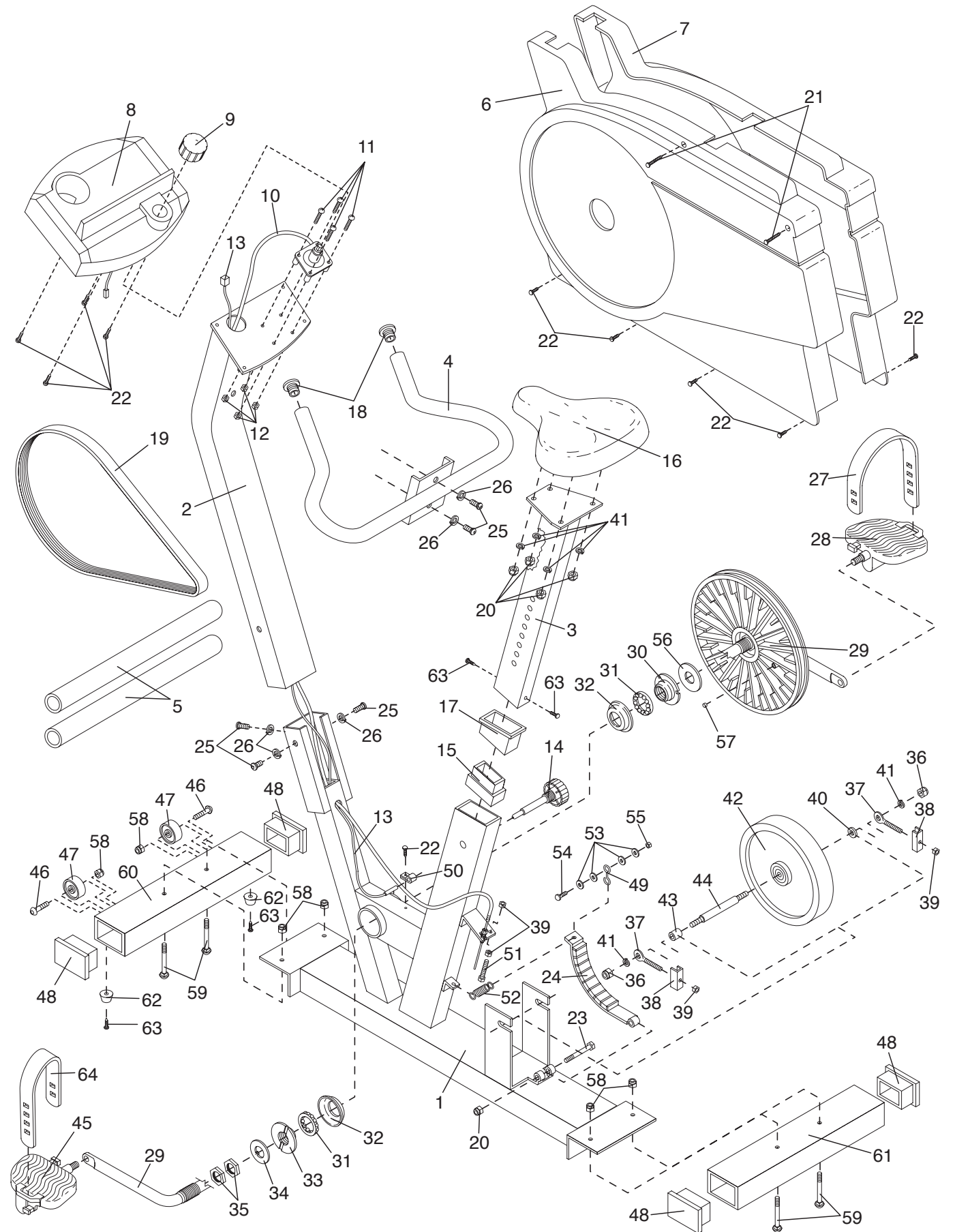

## IMPORTANT PRECAUTIONS

**WARNING:** To reduce the risk of serious injury, read the following important precautions before using the PROFORM® 775s.

1. Read all instructions in this manual before using the 775s.
2. It is the responsibility of the owner to ensure that all users of the 775s are adequately informed of all precautions. Use the 775s only as described in this manual.
3. Use the 775s indoors on a level surface. Keep the 775s away from moisture and dust. Place a mat under the 775s to protect the floor or carpet.
4. Inspect and tighten all parts regularly. Replace any worn parts immediately.
5. Keep children under the age of 12 and pets away from the 775s at all times.
6. The 775s should not be used by persons weighing more than 250 pounds.
7. Wear appropriate clothing when exercising; do not wear loose clothing that could become caught on the 775s. Always wear athletic shoes when using the 775s.
8. Always keep your back straight when using the 775s. Do not arch your back.
9. If you feel pain or dizziness at any time while exercising, stop immediately and begin cooling down.
10. The 775s is intended for in-home use only. Do not use the 775s in a commercial, rental, or institutional setting.
11. When adjusting the seat, insert the seat knob through one of the holes in the seat post. Do not insert the seat knob under the seat post.
12. **CAUTION DECAL PLACEMENT:** The decal shown below has been placed on the 775s. If the decal is missing, or if it is not legible, please call our Customer Service Department toll-free at 1-800-999-3756 to order a free replacement decal. Apply the decal in the location shown.

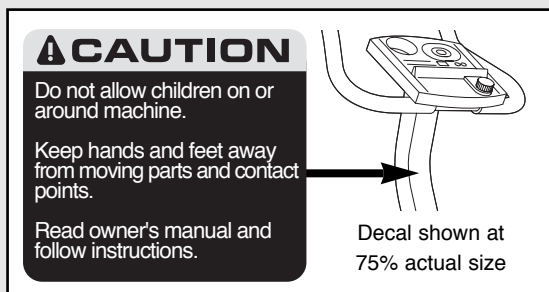

**WARNING:** Before beginning this or any exercise program, consult your physician. This is especially important for persons over age 35 or persons with pre-existing health problems. Read all instructions before using. ICON assumes no responsibility for personal injury or property damage sustained by or through the use of this product.

# PART LIST—Model No. PFEX77572

R0798A

Key No.	Qty.	Description	Key No.	Qty.	Description
1	1	Frame	35	2	Crank Nut
2	1	Upright	36	2	M8 Flanged Hex Nut
3	1	Seat Post	37	2	M6 Eyebolt
4	1	Handlebar	38	2	Adjustment Bracket
5	2	Foam Grip	39	4	M6 Nut
6	1	Left Side Shield	40	1	M10 Washer
7	1	Right Side Shield	41	6	M8 Split Washer
8	1	Console	42	1	Flywheel
9	1	Resistance Knob	43	1	10mm x 13mm Spacer
10	1	Resistance Cable/Control	44	1	Flywheel Axle
11	4	M5 x 30mm Screw	45	1	Left Pedal
12	4	M5 Nut	46	2	M10 x 45mm Button Head Screw
13	1	Reed Switch/Wire	47	2	Wheel
14	1	Lock Knob	48	4	2" x 3" Endcap
15	1	Seat Post Bushing	49	1	Resistance Hook
16	1	Seat	50	1	Reed Switch Clamp
17	1	Frame Bushing	51	1	M6 x 56mm Bolt
18	2	1 1/4" Round Endcap	52	1	Return Spring
19	1	Drive Belt	53	4	#8 Flat Washer
20	5	M8 Nylon Locknut	54	1	Clamp Bolt
21	2	M4 x 38mm Screw	55	1	Clamp Nut
22	13	M4 x 16mm Screw	56	1	Crank Spacer
23	1	M8 x 62mm Hex Head Bolt	57	1	Magnet
24	1	Magnet Bracket	58	6	M10 Nylon Locknut
25	5	M10 x 25mm Button Head Screw	59	4	M10 x 58mm Carriage Bolt
26	5	M10 Split Washer	60	1	Front Stabilizer
27	1	Right Pedal Strap	61	1	Rear Stabilizer
28	1	Right Pedal	62	2	Bumper
29	1	Crank/Pulley	63	4	M4 x 16mm Washer Head Screw
30	1	Notched Bearing Nut	64	1	Left Pedal Strap
31	2	Bearing	#	1	User's Manual
32	2	Bearing Cup	#	1	4mm Allen Wrench
33	1	Slotted Bearing Nut	#	1	5.5mm Allen Wrench
34	1	Crank Washer			

Note: “#” indicates a non-illustrated part. Specifications are subject to change without notice. See the back cover of this manual for information about ordering replacement parts.

## BEFORE YOU BEGIN

Thank you for selecting the innovative PROFORM® 775s. Cycling is one of the most effective exercises known for increasing cardiovascular fitness, building endurance and toning the entire body. The PROFORM 775s features adjustable resistance to let you tailor your exercise to the level that's perfect for you, providing a low-impact, aerobic workout in the convenience and privacy of your own home.

Department toll-free at 1-800-999-3756, Monday through Friday, 6 a.m. until 6 p.m. Mountain Time (excluding holidays). To help us assist you, please note the product model number and serial number before calling. The model number is PFEX77572. The serial number can be found on a decal attached to the 775s (see the front cover of this manual for the location of the decal).

**For your benefit, read this manual carefully before you use the PROFORM 775s.** If you have additional questions, please call our Customer Service

Before reading further, please look at the drawing below and familiarize yourself with the parts that are labeled.

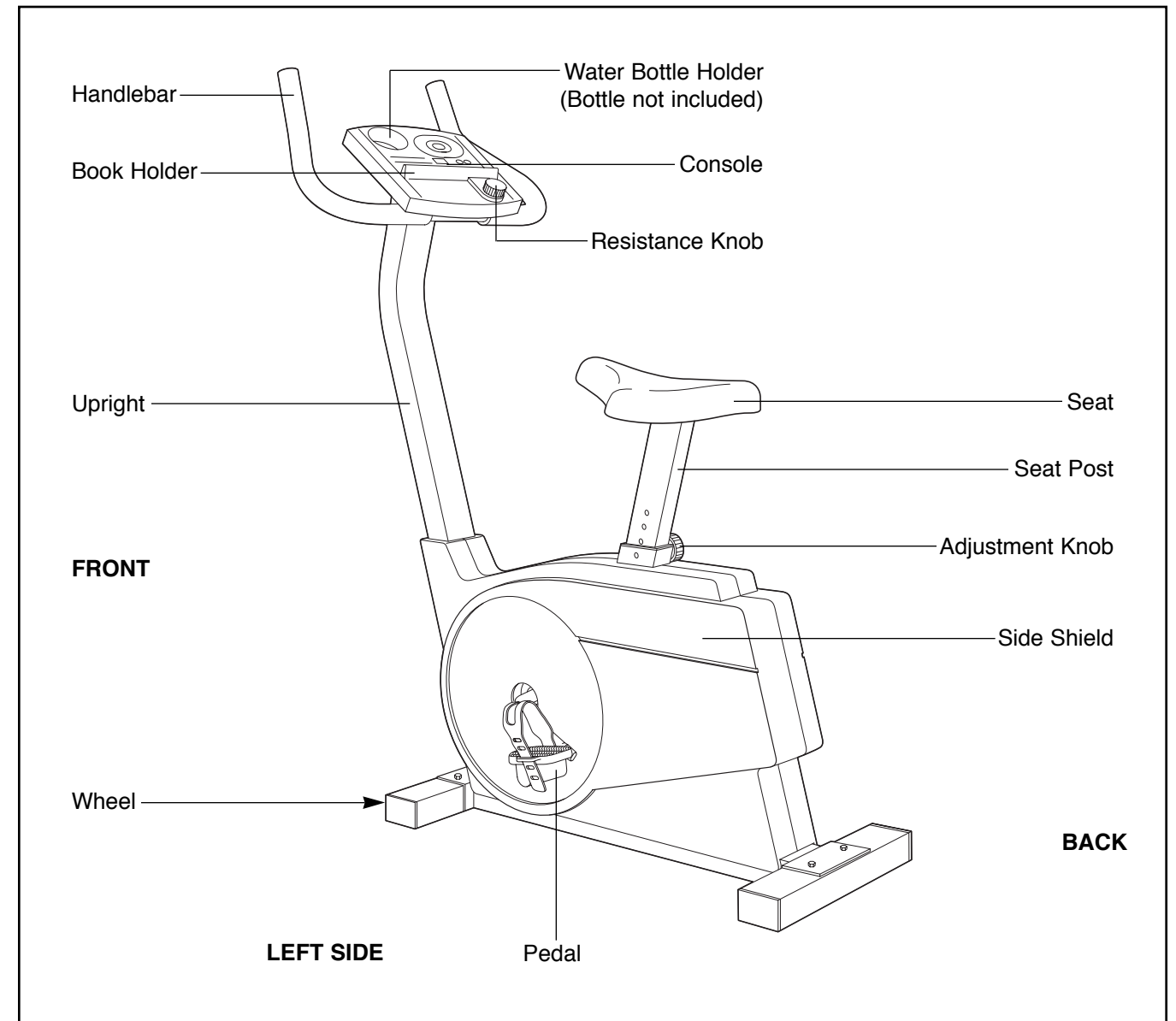

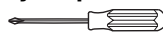

# ASSEMBLY

Place all parts of the exercise bike in a cleared area and remove the packing materials. Do not dispose of the packing materials until assembly is completed. **Assembly requires the included tools, two adjustable wrenches** , **and a phillips screwdriver** .

To identify the small parts used in assembly, refer to the drawings below. The number in parenthesis below each drawing refers to the key number of the part, from the part list on page 11. The second number refers to the quantity used in assembly. **Note: If a part is not in the parts bag, check to see if it has been pre-assembled.**

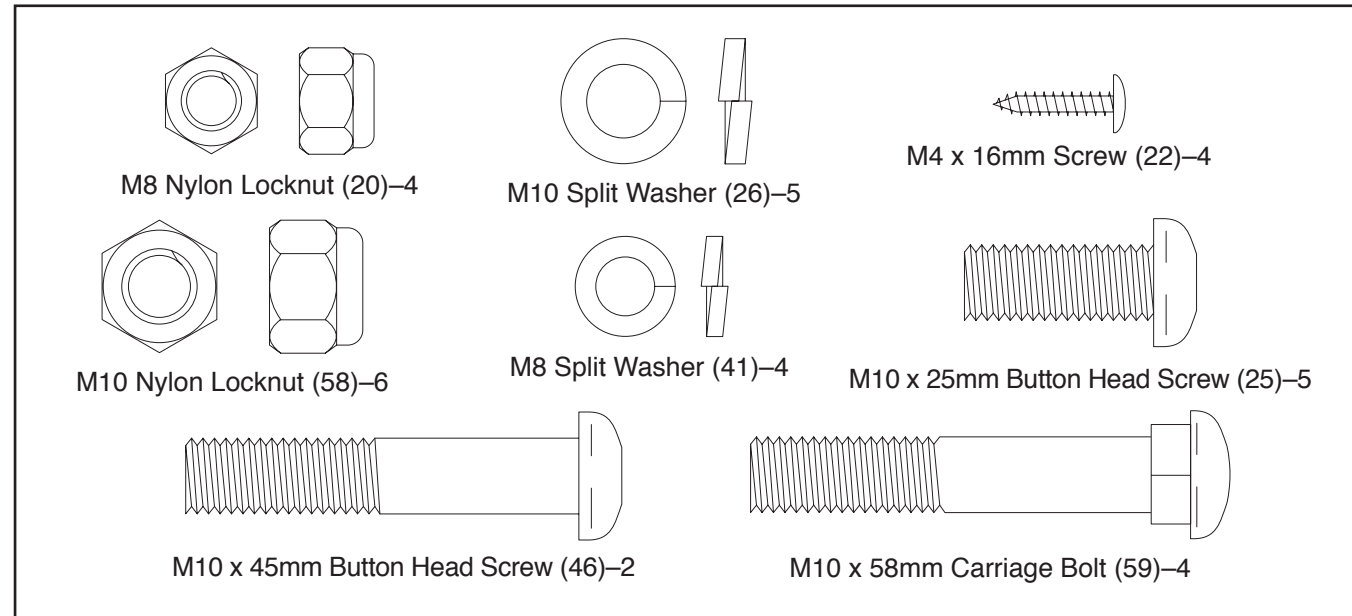

1. Press two 2" x 3" Endcaps (48) into the Rear Stabilizer (61).

Position the Rear Stabilizer (61) under the angled bracket on the rear of the Frame (1). Make sure that the Rear Stabilizer is turned so the recessed holes are on the bottom. Attach the Rear Stabilizer with two M10 x 58mm Carriage Bolts (59) and two M10 Nylon Locknuts (58).

2. Press two 2" x 3" Endcaps (48) into the Front Stabilizer (60). Attach a Wheel (47) to one of the brackets on the Front Stabilizer with an M10 x 45mm Button Head Screw (46) and an M10 Nylon Locknut (58). Attach a Wheel to the other bracket on the Front Stabilizer in the same way.

Position the Front Stabilizer (60) under the angled bracket on the front of the Frame (1). Make sure that the Front Stabilizer is turned so the recessed holes are on the bottom. Attach the Front Stabilizer with two M10 x 58mm Carriage Bolts (59) and two M10 Nylon Locknuts (58).

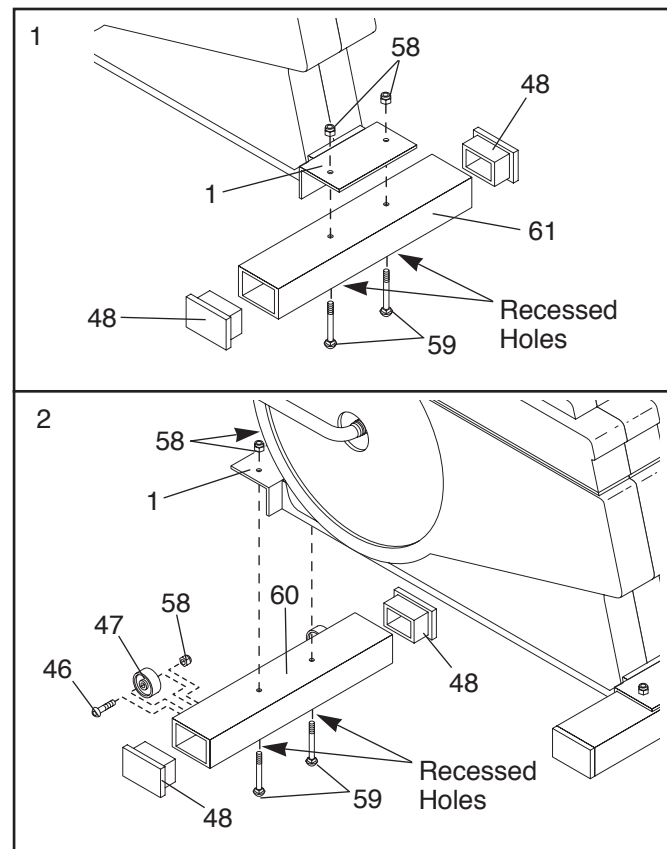

# CONDITIONING GUIDELINES

The following guidelines will help you to plan your exercise program. Remember that proper nutrition and adequate rest are essential for successful results.

**WARNING: Before beginning this or any exercise program, consult your physician. This is especially important for persons over age 35 or persons with pre-existing health problems.**

## EXERCISE INTENSITY

Whether your goal is to burn fat or to strengthen your cardiovascular system, the key to achieving the desired results is to exercise with the proper intensity. The proper intensity level can be found by using your heart rate as a guide. The chart below shows recommended heart rates for fat burning, maximum fat burning, and cardiovascular (aerobic) exercise.

HEART RATE TRAINING ZONES									
MIN	♥	125	120	115	110	105	95	90	Fat Burn
BPM		145	138	130	125	118	110	103	Max Burn
MAX	♥	165	155	145	140	130	125	115	Aerobic
AGE		20	30	40	50	60	70	80	

To find the proper heart rate for you, first find your age at the bottom of the chart (ages are rounded off to the nearest ten years). Next, find the three numbers above your age. The three numbers are your "training zone." The smallest number is the recommended heart rate for fat burning; the middle number is the heart rate for maximum fat burning; the largest number is the heart rate for aerobic exercise.

## Burning Fat

To burn fat effectively, you must exercise at a relatively low intensity level for a sustained period of time. During the first few minutes of exercise, your body uses easily accessible carbohydrate calories for energy. Only after the first few minutes of exercise does your body begin to use stored fat calories for energy. If your goal is to burn fat, adjust the intensity of your exercise until your heart rate is near the smallest number in your training zone as you exercise.

For maximum fat burning, adjust the intensity of your exercise until your heart rate is near the middle number in your training zone as you exercise.

## Aerobic Exercise

If your goal is to strengthen your cardiovascular system, your exercise must be "aerobic." Aerobic exercise is activity that requires large amounts of oxygen for prolonged periods of time. This increases the demand on the heart to pump blood to the muscles, and on the lungs to oxygenate the blood. For aerobic exercise, adjust the intensity of your exercise until your heart rate is near the largest number in your training zone.

## HOW TO MEASURE YOUR HEART RATE

To measure your heart rate, first exercise for at least four minutes. Then, stop exercising and place two fingers on your wrist as shown. Take a six-second heartbeat count, and multiply the result by 10 to find your heart rate. For example, if your six-second heartbeat count is 14, your heart rate is 140 beats per minute. (A six-second count is used because your heart rate will drop rapidly when you stop exercising.)



## WORKOUT GUIDELINES

Each workout should include the following three important parts: **A warm-up**, consisting of 5 to 10 minutes of stretching and light exercise. A proper warm-up increases your body temperature, heart rate, and circulation in preparation for exercise. **Training zone exercise**, consisting of 20 to 30 minutes of exercising with your heart rate in your training zone. (During the first few weeks of your exercise program, do not keep your heart rate in your training zone for longer than 20 minutes.) **A cool-down**, with 5 to 10 minutes of stretching. This will increase the flexibility of your muscles and will help to prevent post-exercise problems.

## EXERCISE FREQUENCY

To maintain or improve your condition, plan three workouts each week, with at least one day of rest between workouts. After a few months of regular exercise, you may plan up to five workouts each week, if desired. **Caution: Be sure to progress at your own pace and avoid overdoing it. Incorrect or excessive training may result in injury to your health.** Remember, the key to success is to make exercise a regular and enjoyable part of your everyday life.

# MAINTENANCE AND TROUBLE-SHOOTING

Inspect and tighten all parts of the PROFORM® 775S regularly. The 775S can be cleaned with a soft, damp cloth. To prevent damage to the console, keep liquids away and keep the console out of direct sunlight.

## BATTERY REPLACEMENT

If the console does not function properly, the batteries should be replaced. To replace the batteries, refer to assembly step 8 on page 6.

## HOW TO ADJUST THE REED SWITCH

If the console does not display correct feedback, the reed switch should be adjusted. In order to adjust the reed switch, the Left Side Shield (6) must be removed. First, using an adjustable wrench, turn the Left Pedal (45) clockwise to remove the Pedal from the left arm of the Crank (29).

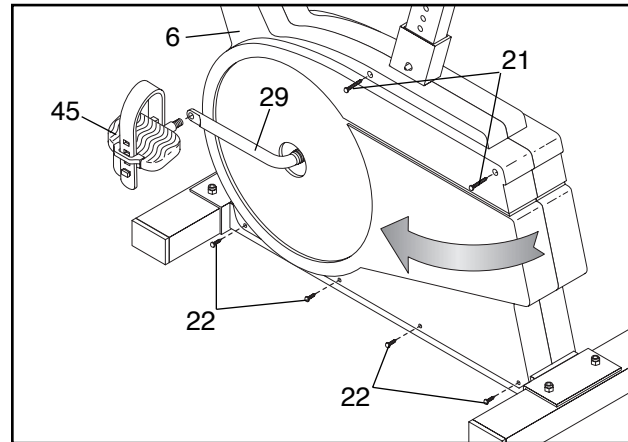

Remove all Screws (21, 22) from the Left Side Shield (6). Grasp both Side Shields at the top and gently pull them apart. Make sure that the arm of the Crank (29) is in the position shown in the drawing above. Hold the Left Side Shield at the rear and pull it gently away from the frame. Work the Left Side Shield forward off the arm of the Crank and remove it.

Next, locate the Reed Switch (13). Loosen, but do not remove, the M4 x 16mm Screw (22). Slide the Reed Switch slightly toward or away from the Magnet (57) on the pulley. Retighten the Screw. Turn the Crank (29) for a moment. Repeat until the console

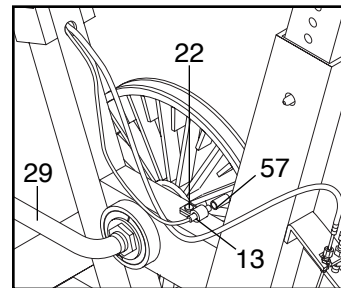

displays correct feedback. When the Reed Switch is correctly adjusted, reattach the left side shield.

## HOW TO ADJUST THE DRIVE BELT

If you can feel the pedals slip when you are exercising, especially when the resistance knob is turned to the maximum setting, the Drive Belt (19) may need to be adjusted. To adjust the Drive Belt, both side shields must be removed. Refer to the instructions at the left to remove the left side shield. Remove the right side shield in the same manner.

Loosen the M8 Flanged Hex Nut (36) on each side of the Flywheel (42). Tighten the M6 Nut (39) on each M6 Eyebolt (37) until the Drive Belt (19) is tight. **Be sure that you tighten each M6 Nut an equal amount.** Once the Drive Belt is tight, tighten the M8 Flanged Hex Nuts (36). Reattach the side shields.

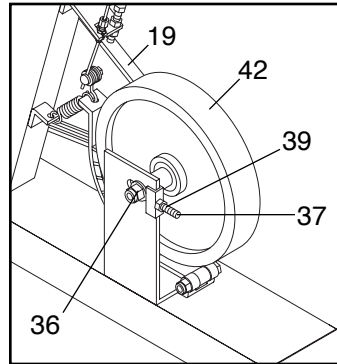

## CRANK ADJUSTMENT

If the arms of the Crank (29) become loose, they should be tightened in order to prevent excessive wear. Loosen the Crank Nut (35) on the left arm of the Crank. Place the end of a standard screwdriver in one of the slots in the Slotted Bearing Nut (33). Lightly tap the screwdriver with a hammer to turn the Slotted Bearing Nut counterclockwise until the arms are no longer loose. **Do not overtighten the Slotted Bearing Nut.** When the Slotted Bearing Nut is properly tightened, tighten the Crank Nut.

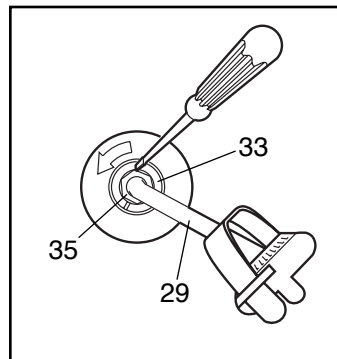

## STORAGE

When storing the exercise bike, remove the batteries from the console. Keep the exercise bike in a clean, dry location, away from moisture and dust.

3 Attach the Upright (2) to the Frame (1) with three M10 x 25mm Button Head Screws (25) and three M10 Split Washers (26). **Be careful not to pinch the Reed Switch Wire (13) or the Resistance Cable (10).**

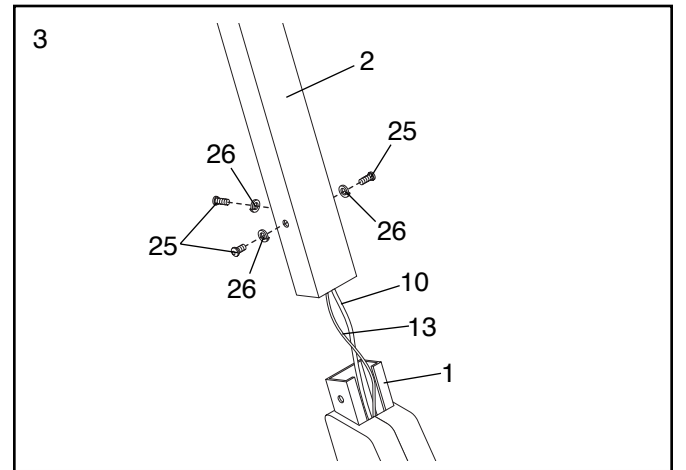

4. Connect the Reed Switch Wire (13) to the wire on the back of the Console (8).

Attach the Console (8) to the Upright (2) with four M4 x 16mm Screws (22).

Press the Resistance Knob (9) onto the Resistance Control (10). Be sure that the mark on the Resistance Knob is correctly aligned.

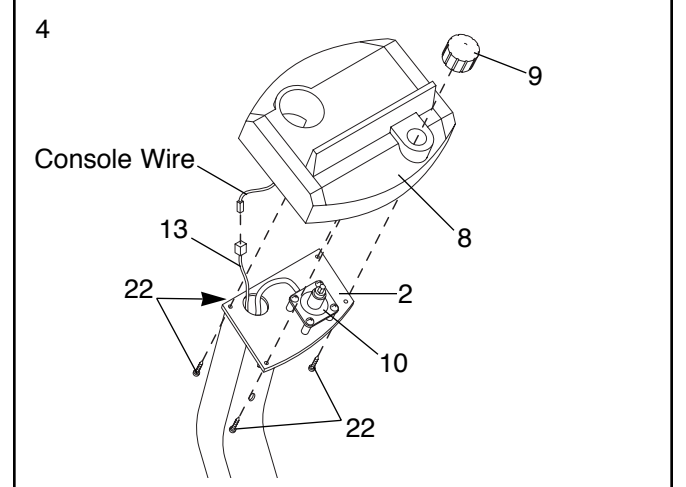

5. Attach the Handlebar (4) to the Upright (2) with two M10 x 25mm Button Head Screws (25) and two M10 Split Washers (26).

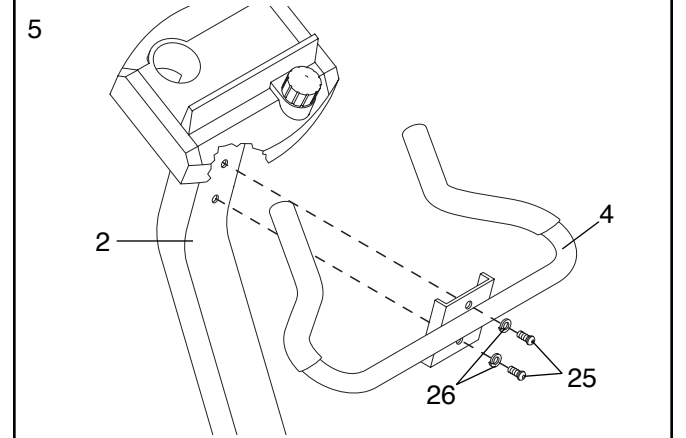

6. Attach the Seat (16) to the Seat Post (3) with four M8 Split Washers (41) and four M8 Nylon Locknuts (20).

Insert the Seat Post (3) into the Frame (1). Press the Frame Bushing (17) into place in the Frame.

Align one of the holes in the Seat Post (3) with the hole in the Frame (1). Insert the Lock Knob (14) into the Frame and the Seat Post. Tighten the Lock Knob.

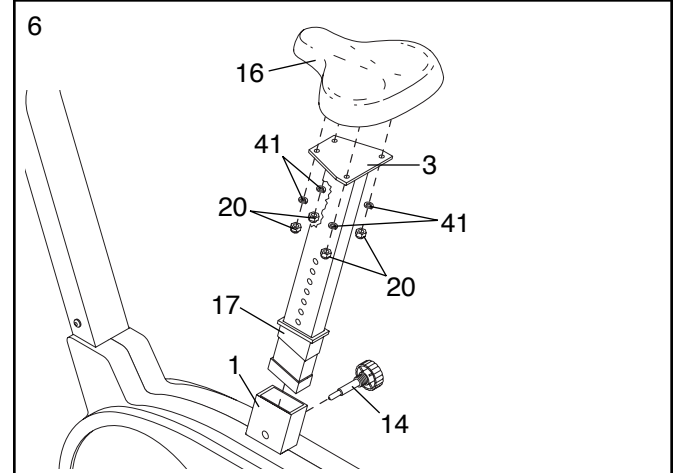

- Identify the Left Pedal (45) (there is an “L” on the Left Pedal for identification). Using an adjustable wrench, tighten the Left Pedal counterclockwise into the left arm of the Crank (29).

Tighten the Right Pedal (not shown) clockwise into the right arm of the Crank (29).

Adjust the Pedal Strap (64) on the Left and Right Pedals to the desired position. Press the Pedal Strap onto the adjustment tab on both Pedals.

- The Console (8) requires two “AA” batteries (not included); alkaline batteries are recommended. Open the battery cover (not shown) on the back of the Console. Press two batteries into the battery clip. **Make sure that the negative ends of the batteries (marked “-”) are touching the springs.** Close the battery cover.

- Make sure that all parts are properly tightened before you use the exercise bike.**

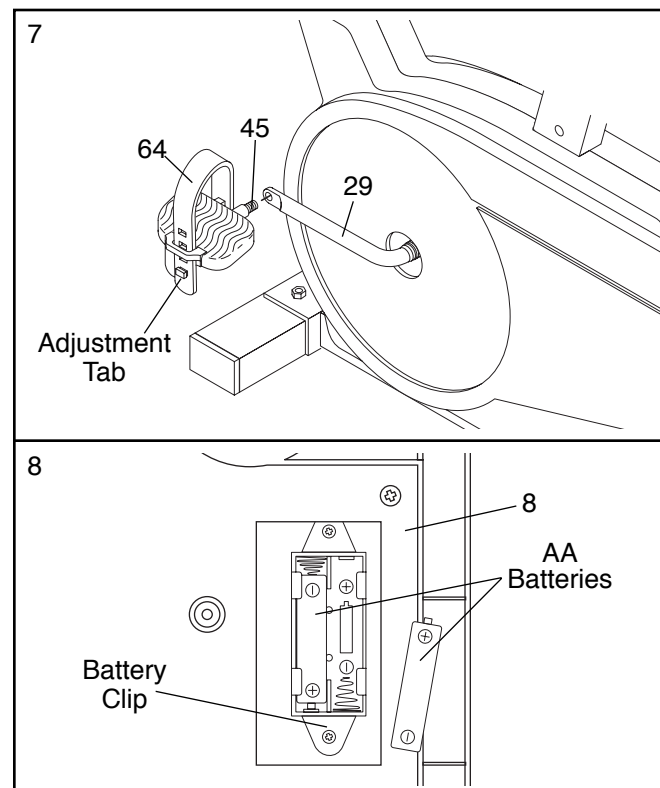

## HOW TO USE THE PROFORM® 775S

### HOW TO ADJUST THE SEAT POST

The Seat Post (3) can be adjusted to the position that is the most comfortable for you. To adjust the Seat Post, first loosen and remove the Lock Knob (14) on the right side of the Frame (1). Slide the Seat Post up or down to the desired position. Insert the Lock Knob through one of the holes in the Seat Post and tighten it. **Do not insert the Lock Knob under the Seat Post.**

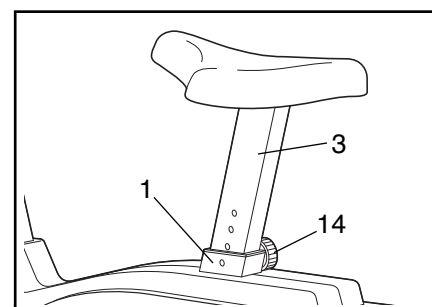

### HOW TO ADJUST THE PEDAL STRAPS

To adjust each Pedal Strap (64), first pull the end of the Pedal Strap off the adjustment tab on the Pedal (45). Align a different hole in the Pedal Strap with the adjustment tab. Press the Pedal Strap onto the adjustment tab.

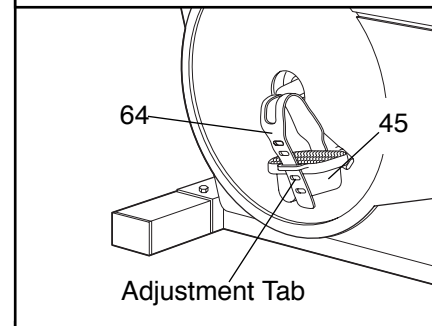

### HOW TO ADJUST THE PEDALING RESISTANCE

The pedaling resistance can be adjusted with the Resistance Knob (9) located on the Console (8). To increase the resistance, turn the Resistance Knob clockwise; to decrease the resistance, turn the Resistance Knob counterclockwise.

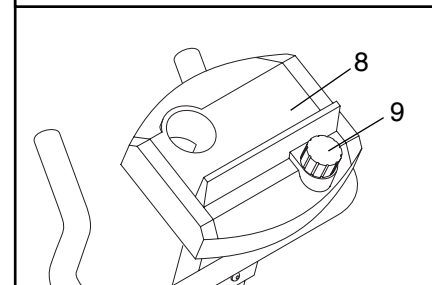

## DESCRIPTION OF THE CONSOLE

The console is designed to help you get the most from your workouts. As you exercise, you can watch your progress around the LED track, while the display provides continuous exercise feedback. The six modes of the display are described below.

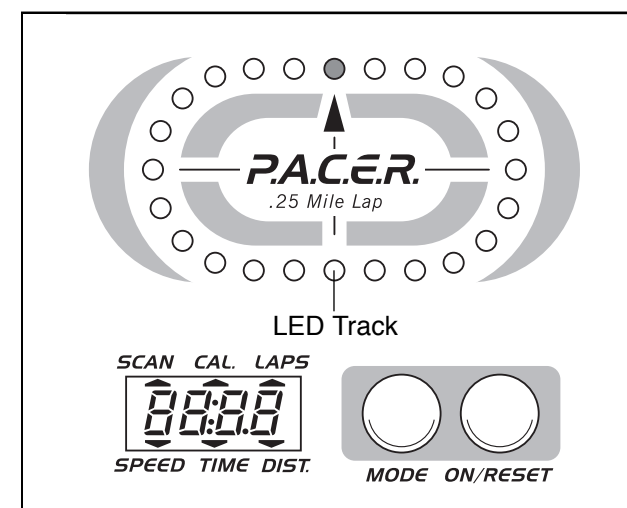

**Speed**—This mode displays your current pedaling speed, in miles per hour.

**Time**—This mode displays the length of time you have exercised. Note: If you stop exercising, the time mode will pause until you resume.

**Distance**—This mode displays the total distance you have pedaled, in miles.

**Laps**—This mode displays the number of 1/4-mile laps you have completed around the LED track.

**Calorie**—This mode displays the approximate number of Calories you have burned.

**Scan**—This mode displays the speed, time, distance, laps, and calorie modes, for 5 seconds each, in a repeating cycle.

### BATTERY INSTALLATION

Before the console can be operated, two “AA” batteries must be installed. If you have not installed batteries, see assembly step 6 on page 5.

## HOW TO OPERATE THE CONSOLE

If there is a thin sheet of clear plastic on the face of the console, remove it.

- To turn on the power, press the on/reset button or simply begin pedaling. When the power is turned on, one LED indicator will light in the LED track, and the entire display will appear for two seconds. The console will then be ready for operation.

- Select one of the five modes:

**Scan mode**—When the power is turned on, the scan mode will automatically be selected. One mode indicator will show that the scan mode is selected, and a flashing mode indicator will show which mode is currently displayed. Note: If a different mode is selected, you can select the scan mode again by repeatedly pressing the mode button.

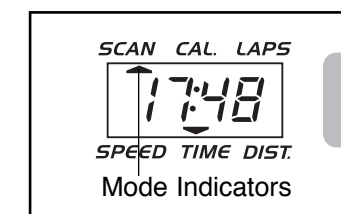

**Speed, time, distance, laps, or calorie mode**—To select one of these modes for continuous display, press the mode button repeatedly. The mode indicators will show which mode is selected. (Make sure that the scan mode is not selected.)

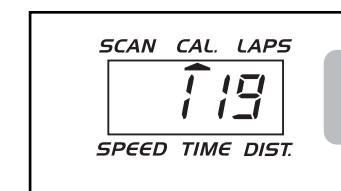

- The LED track represents a distance of 1/4 mile. As you exercise, the indicators around the track will light one at a time until you have completed 1/4 mile. A new lap will then begin.
- To reset the display, press the on/reset button.
- To turn off the power, simply wait for about four minutes. **Note: The console has an “auto-off” feature. If the pedals are not moved and the console buttons are not pressed for four minutes, the power will turn off automatically in order to conserve the batteries.**