

# PRO-FORM<sup>®</sup>

## EXERCISE BIKE

[www.proform.com](http://www.proform.com)

Model No. PFEX78914.1

Serial No. \_\_\_\_\_

Write the serial number in the space above for reference.

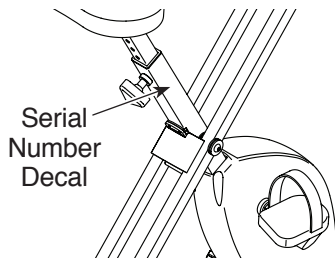

### ACTIVATE YOUR WARRANTY

To register your product and activate your warranty today, go to [www.proformservice.com/registration](http://www.proformservice.com/registration).

### CUSTOMER CARE

For service at any time, go to [www.proformservice.com](http://www.proformservice.com).

Or call 1-888-533-1333  
Mon.–Fri. 6 a.m.–6 p.m. MT  
Sat. 8 a.m.–12 p.m. MT

Please do not contact the store.

### ⚠ CAUTION

Read all precautions and instructions in this manual before using this equipment. Keep this manual for future reference.

## USER'S MANUAL

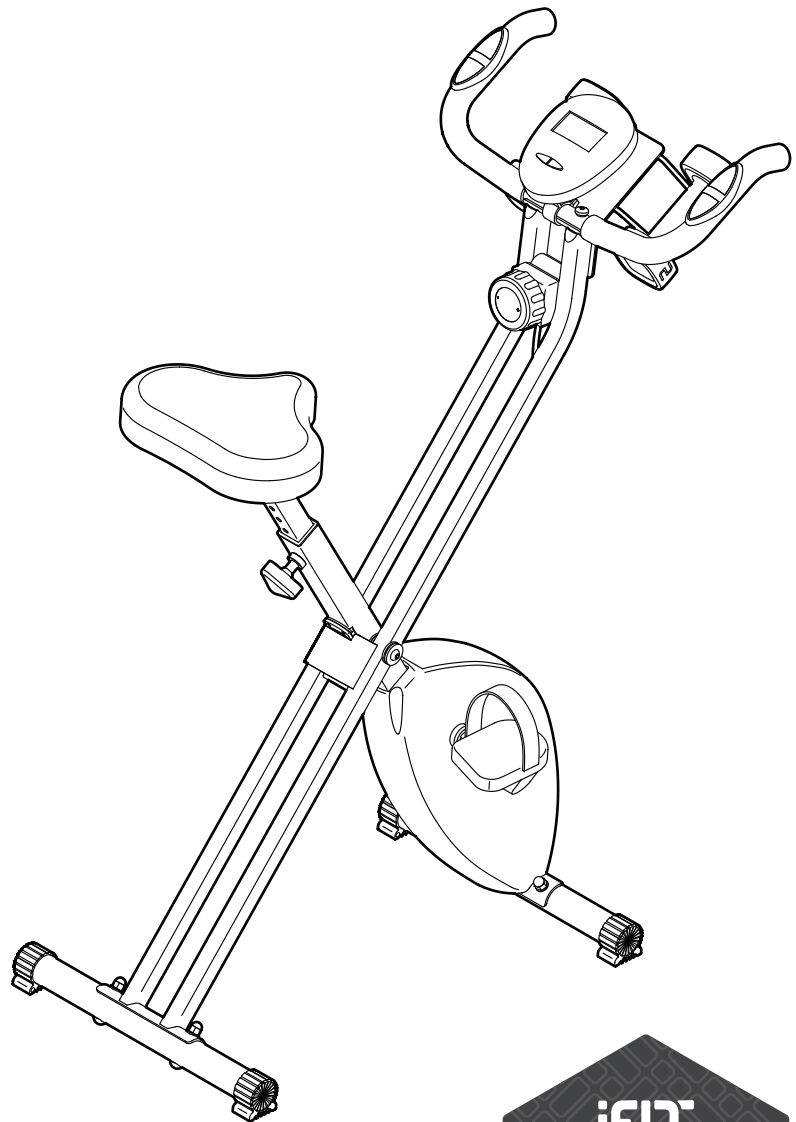

# TABLE OF CONTENTS

WARNING DECAL PLACEMENT .....	2
IMPORTANT PRECAUTIONS .....	3
BEFORE YOU BEGIN .....	5
PART IDENTIFICATION CHART .....	6
ASSEMBLY .....	7
HOW TO USE THE EXERCISE BIKE .....	11
FCC INFORMATION .....	14
MAINTENANCE AND TROUBLESHOOTING .....	14
EXERCISE GUIDELINES .....	15
ORDERING REPLACEMENT PARTS .....	Back Cover
LIMITED WARRANTY .....	Back Cover

## WARNING DECAL PLACEMENT

This drawing shows the location(s) of the warning decal(s). **If a decal is missing or illegible, see the front cover of this manual and request a free replacement decal. Apply the decal in the location shown.** Note: The decal(s) may not be shown at actual size.

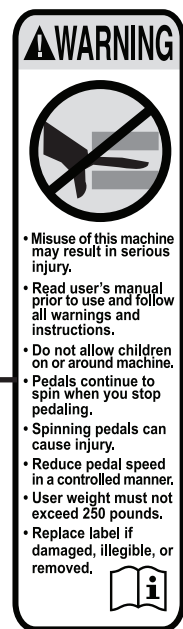
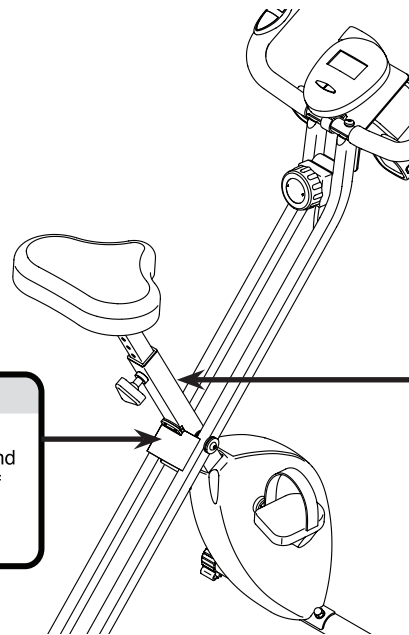

---

# IMPORTANT PRECAUTIONS

**⚠ WARNING:** To reduce the risk of serious injury, read all important precautions and instructions in this manual and all warnings on your exercise bike before using your exercise bike. ICON assumes no responsibility for personal injury or property damage sustained by or through the use of this product.

1. It is the responsibility of the owner to ensure that all users of the exercise bike are adequately informed of all precautions.
2. Before beginning any exercise program, consult your physician. This is especially important for persons over age 35 or persons with pre-existing health problems.
3. Use the exercise bike only as described in this manual.
4. The exercise bike is intended for home use only. Do not use the exercise bike in a commercial, rental, or institutional setting.
5. Keep the exercise bike indoors, away from moisture and dust. Do not put the exercise bike in a garage or covered patio, or near water.
6. Place the exercise bike on a level surface, with a mat beneath it to protect the floor or carpet. Make sure that there is at least 2 ft. (0.6 m) of clearance around the exercise bike.
7. Inspect and properly tighten all parts regularly. Replace any worn parts immediately.
8. Keep children under age 12 and pets away from the exercise bike at all times.
9. Wear appropriate clothes while exercising; do not wear loose clothes that could become caught on the exercise bike. Always wear athletic shoes for foot protection.
10. The exercise bike should not be used by persons weighing more than 250 lbs. (113 kg).
11. Be careful when mounting and dismounting the exercise bike.
12. Always keep your back straight while using the exercise bike; do not arch your back.
13. The heart rate monitor is not a medical device. Various factors may affect the accuracy of heart rate readings. The heart rate monitor is intended only as an exercise aid in determining heart rate trends in general.
14. The exercise bike does not have a freewheel; the pedals will continue to move until the flywheel stops. Reduce your pedaling speed in a controlled way.
15. Over exercising may result in serious injury or death. If you feel faint, if you become short of breath, or if you experience pain while exercising, stop immediately and cool down.

# PROTECT

YOUR FITNESS EQUIPMENT  
WITH AN EXTENDED SERVICE PLAN



Your new fitness equipment is not an ordinary purchase; it is an investment in your health and well being for years to come.

As the leading provider of manufacturer's extended service plans, ICON strives to protect your equipment and your future.

Please review the following service plans and find one that best fits your needs.

## PREVENTIVE MAINTENANCE SERVICE PLANS

Equipment Price	3-Year Plan	5-Year Plan
\$0.00 to \$1000.00	\$199.99	\$289.99
\$1001.00 to \$1500.00	\$259.99	\$379.99
\$1501.00 to \$2500.00	\$339.99	\$489.99
(Bikes/Systems Only) \$0.00 to \$2500.00	\$139.99	NA

Features:

- Includes an annual preventive maintenance and performance check at your convenience
- Unlimited in-home repairs; no shipping required
- Covers parts and labor on all manufacturer's defects, as well as wear and tear on parts
- Up to 5 years of coverage available

## STANDARD SERVICE PLANS

Equipment Price	1-Year Plan	2-Year Plan	3-Year Plan
\$0.00 to \$300.00	\$29.99	\$39.99	\$59.99
\$301.00 to \$1000.00	\$89.99	\$119.99	\$149.99
\$1001.00 to \$2000.00	\$109.99	\$139.99	\$179.99
\$2001.00 to \$3000.00	\$179.99	\$209.99	\$239.99

Features:

- Unlimited in-home repairs; no shipping required
- Covers parts and labor on all manufacturer's defects, as well as wear and tear on parts
- Up to 3 years of coverage available

To protect your fitness equipment today, please  
call Customer Care at **1-800-677-3838.**  
Or, visit us online at **www.utserv.com.**



# BEFORE YOU BEGIN

Thank you for selecting the new PROFORM® exercise bike. Cycling is an effective exercise for increasing cardiovascular fitness, building endurance, and toning the body. The PROFORM exercise bike provides a selection of features designed to make your workouts at home more effective and enjoyable.

**For your benefit, read this manual carefully before you use the exercise bike.** If you have questions after

reading this manual, please see the front cover of this manual. To help us assist you, note the product model number and serial number before contacting us. The model number and the location of the serial number decal are shown on the front cover of this manual.

Before reading further, please review the drawing below and familiarize yourself with the labeled parts.

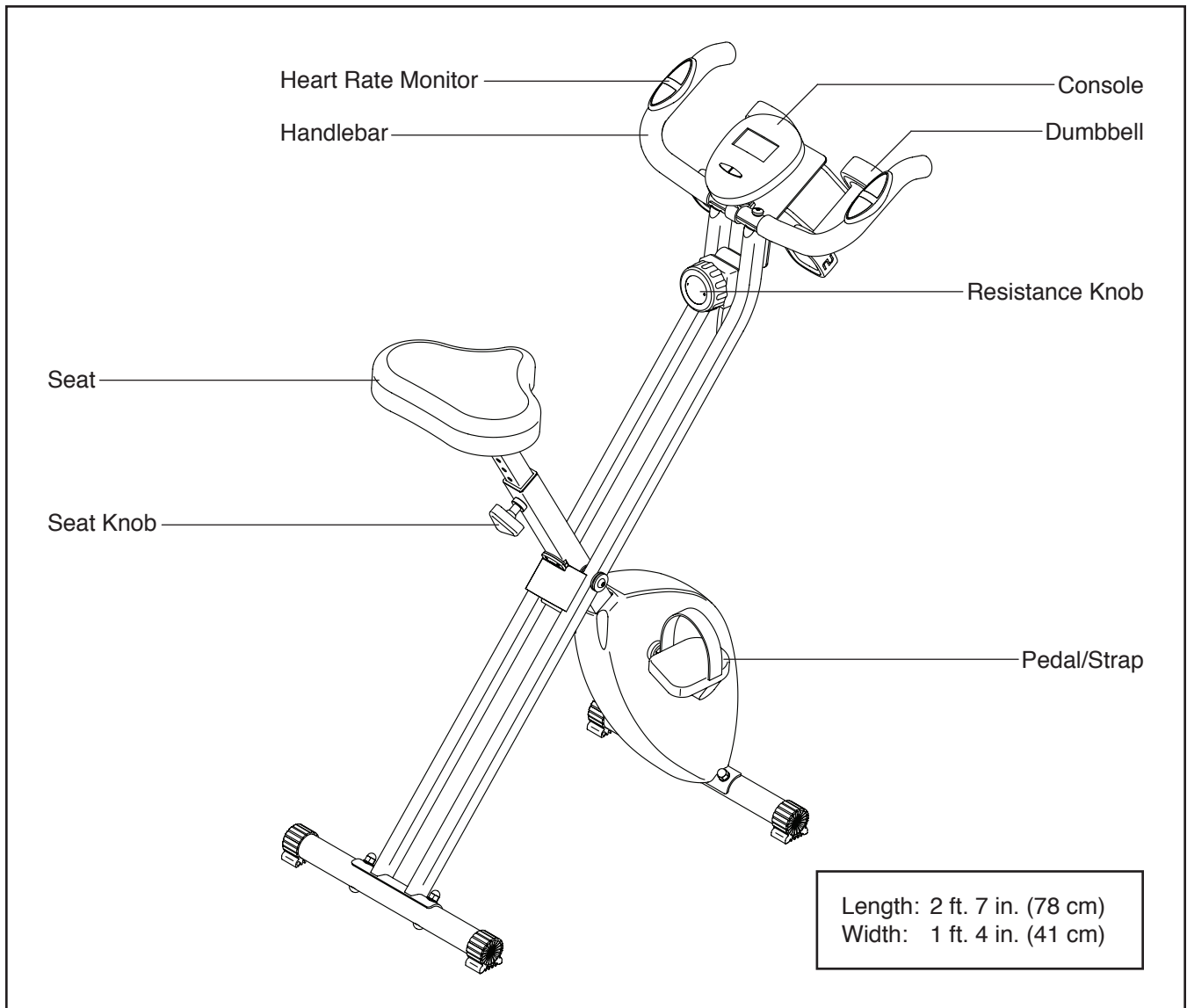

# PART IDENTIFICATION CHART

Use the drawings below to identify the small parts needed for assembly. The number in parentheses below each drawing is the key number of the part. The number following the key number is the quantity needed for assembly. **Note: If a part is not in the hardware kit, check to see if it has been preassembled. Extra parts may be included.**

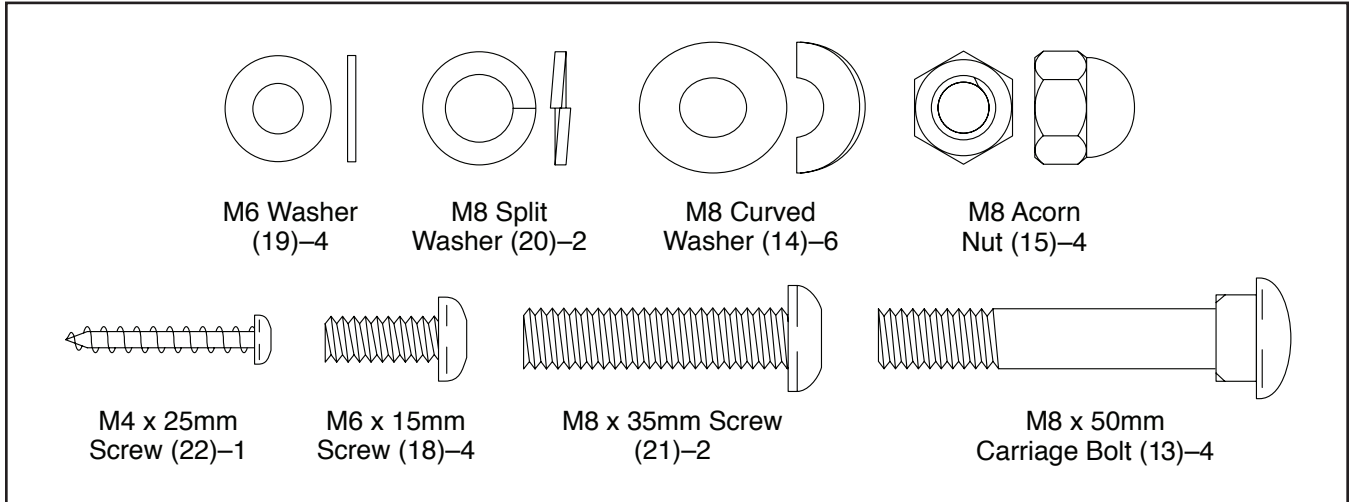

# ASSEMBLY

- To hire an authorized service technician to assemble this product, call 1-800-445-2480.
- Assembly requires two persons.
- Place all parts in a cleared area and remove the packing materials. Do not dispose of the packing materials until you finish all assembly steps.
- Left parts are marked “L” or “Left” and right parts are marked “R” or “Right.”

- In addition to the included tool(s), assembly requires the following tool(s):

one Phillips screwdriver 

one adjustable wrench 

Assembly may be easier if you have a set of wrenches. To avoid damaging parts, do not use power tools.

**1. Go to [www.proformservice.com/registration](http://www.proformservice.com/registration) on your computer and register your product.**

- activates your warranty
- saves you time if you ever need to contact Customer Care
- allows us to notify you of upgrades and offers

Note: If you do not have Internet access, call Customer Care (see the front cover of this manual) and register your product.

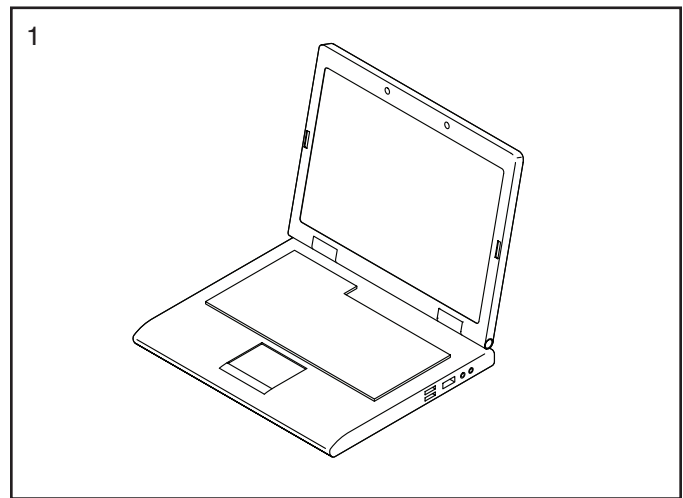

**2. Attach one of the Stabilizers (3) to the Handlebar Frame (1) with two M8 x 50mm Carriage Bolts (13), two M8 Curved Washers (14), and two M8 Acorn Nuts (15).**

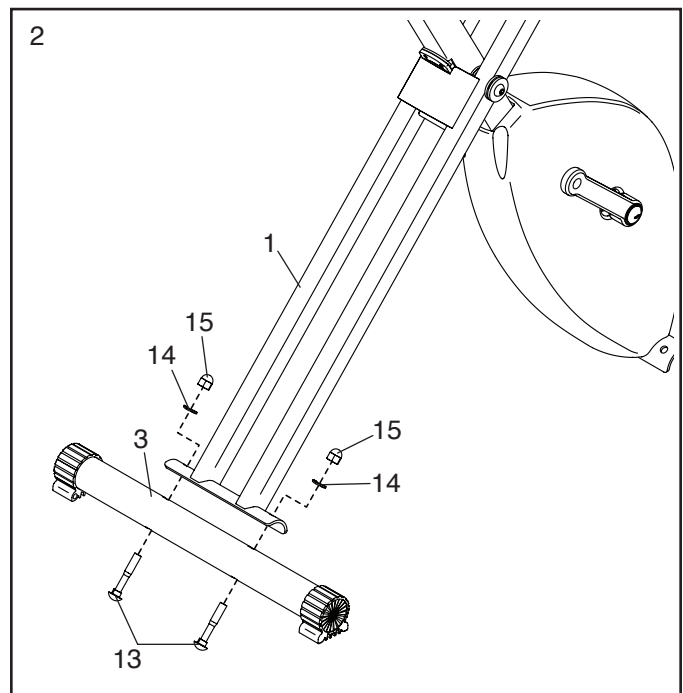

3. Attach the other Stabilizer (3) to the Seat Frame (2) with two M8 x 50mm Carriage Bolts (13), two M8 Curved Washers (14), and two M8 Acorn Nuts (15).

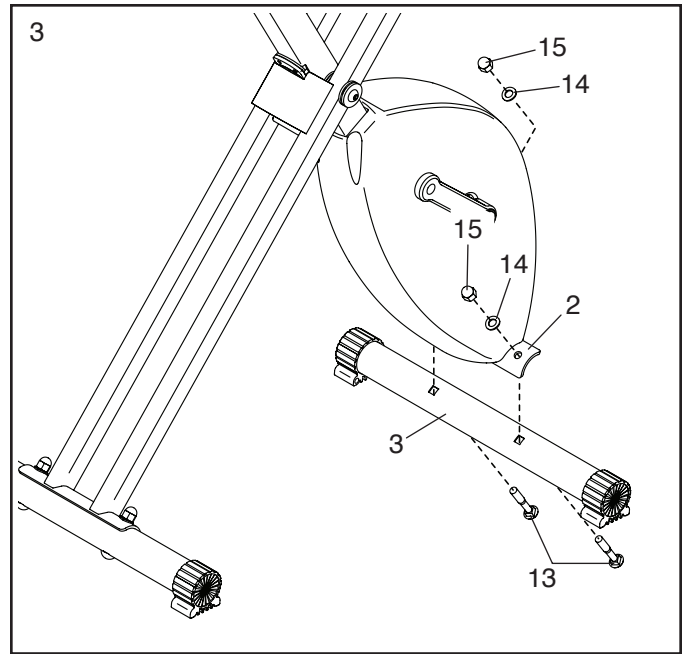

4. Attach the Seat (5) to the Seat Post (4) with three M8 Locknuts (16) and three M8 Washers (17).

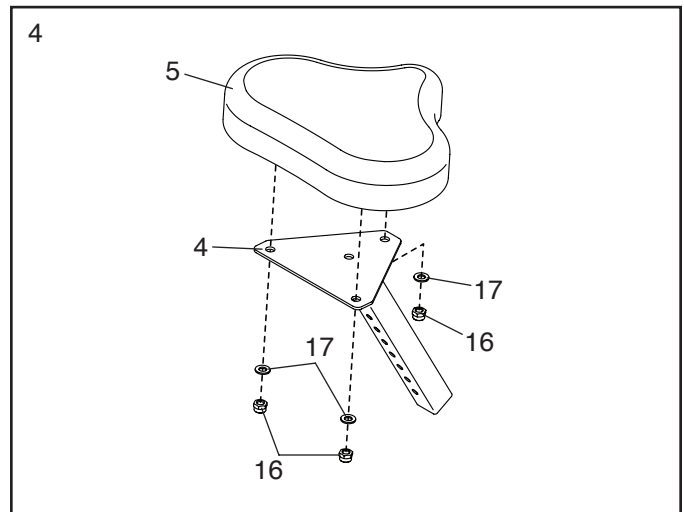

5. Insert the Seat Post (4) into the Seat Frame (2).

Next, insert the Seat Knob (12) into the Seat Frame (2) and into one of the adjustment holes in the Seat Post (4); **make sure that the Seat Knob is in one of the adjustment holes in the Seat Post.** Then, tighten the Seat Knob.

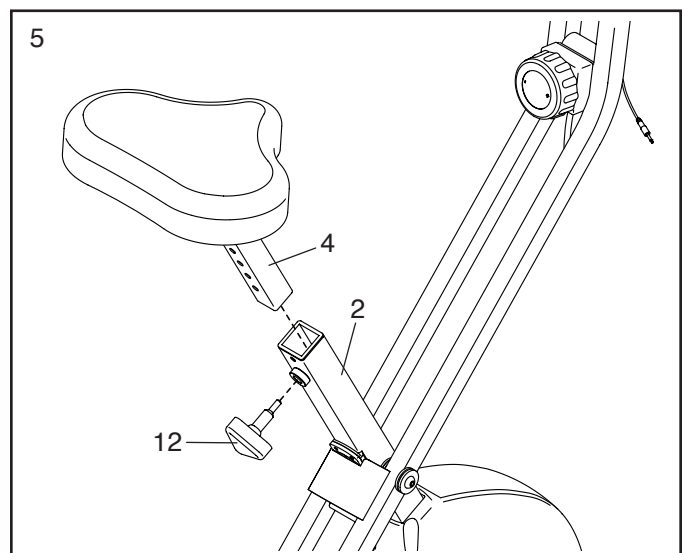



6. Attach the Handlebar (6) to the Handlebar Frame (1) with two M8 x 35mm Screws (21), two M8 Split Washers (20), and two M8 Curved Washers (14).

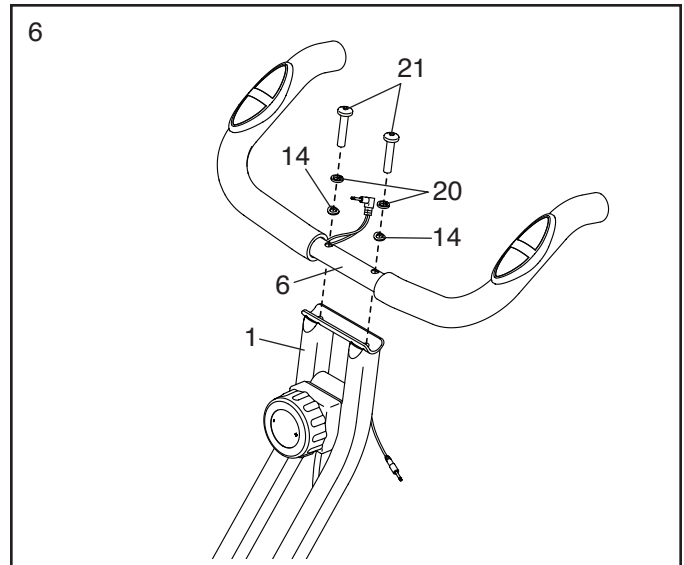

7. Pull the Console Mount (7) open slightly and slide it onto the Handlebar (6) and onto the upper end of the Handlebar Frame (1). Then, tighten an M4 x 25mm Screw (22) into the Console Mount; **do not fully tighten the Screw yet.**

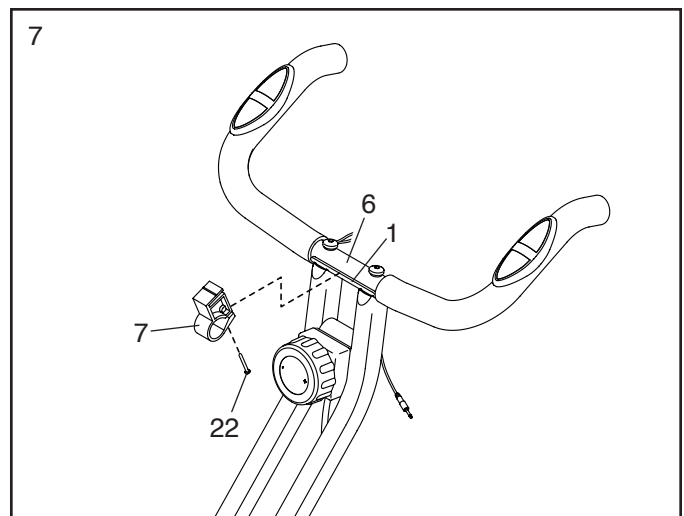

8. The Console (8) requires two AA batteries (not included); alkaline batteries are recommended. Do not use old and new batteries together or alkaline, standard, and rechargeable batteries together. **IMPORTANT: If the Console has been exposed to cold temperatures, allow it to warm to room temperature before you insert batteries. Otherwise, you may damage the console displays or other electronic components.**

Press the tab on the battery cover, and remove the battery cover. Next, insert two batteries into the battery compartment; **make sure to orient the batteries as shown by the diagram inside the battery compartment.** Then, reattach the battery cover.

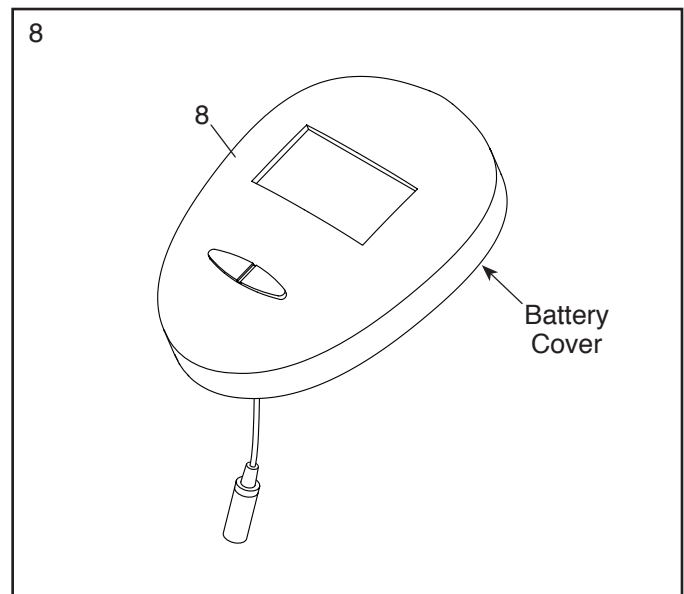

9. Have a second person hold the Console (8) near the Console Mount (7). Connect the wire on the Console to the Reed Switch Wire (23). Then, plug the Monitor Wire (24) into the back of the Console.

**Tip: Avoid pinching the wires.** Slide the Console (8) onto the Console Mount (7). Then, pivot the Console and the Console Mount to the desired angle.

**See step 7.** Tighten the M4 x 25mm Screw (22).

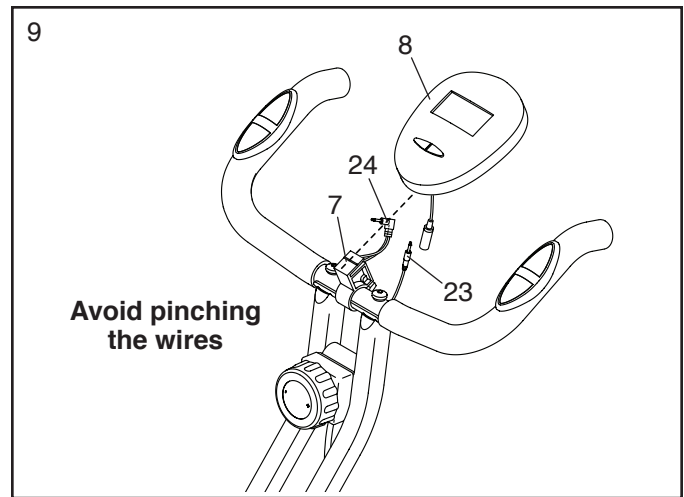

10. Attach the Dumbbell Rack (9) to the Handlebar Frame (1) with four M6 x 15mm Screws (18) and four M6 Washers (19); **start all the Screws, and then tighten them.**

**See the inset drawing.** Set the two Dumbbells (10) on the Dumbbell Rack (9).

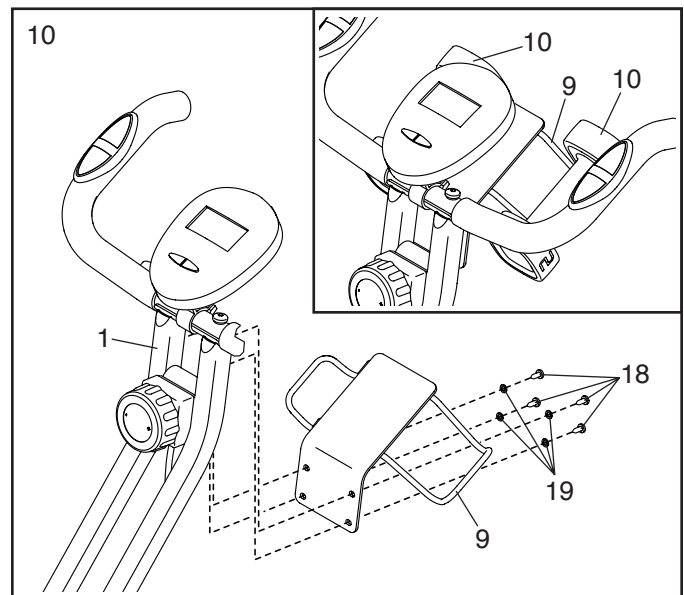

11. Identify the Right Pedal (11).

Using an adjustable wrench, **firmly tighten** the Right Pedal (11) **clockwise** into the Right Crank Arm (25).

**Firmly tighten the Left Pedal (not shown) counterclockwise into the Left Crank Arm (not shown). IMPORTANT: You must turn the Left Pedal counterclockwise to attach it.**

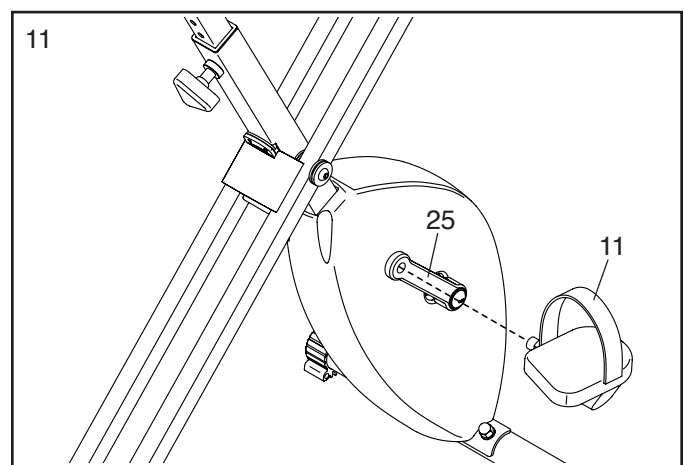

12. **After the exercise bike is assembled, inspect it to make sure that it is assembled correctly and that it functions properly. Make sure that all parts are properly tightened before you use the exercise bike.** Extra parts may be included. Place a mat under the exercise bike to protect the floor.

# HOW TO USE THE EXERCISE BIKE

## HOW TO ADJUST THE SEAT POST

For effective exercise, the seat should be at the proper height. As you pedal, there should be a slight bend in your knees when the pedals are in the lowest position.

To adjust the height of the seat, first loosen and remove the seat knob. Next, slide the seat post upward or downward and align one of the adjustment holes in the seat post with the hole in the frame. Insert the seat knob into the frame and the seat post, and then tighten the seat knob. **Make sure that the seat knob is inserted into one of the adjustment holes in the seat post.**

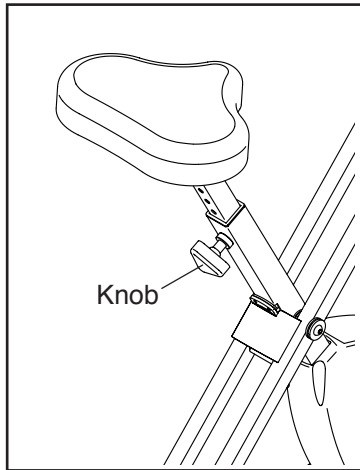

## HOW TO USE THE DUMBBELLS

To add upper body exercise to your workouts, use the dumbbells while you pedal. When you are not using the dumbbells, store them on the dumbbell rack.

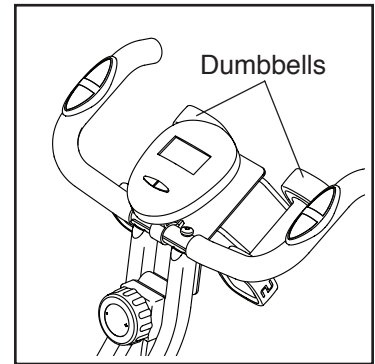

## HOW TO FOLD THE EXERCISE BIKE

When the exercise bike is not in use, it can be folded to a compact position. First, remove the dumbbells from the dumbbell rack. Then, hold the handlebar with one hand, hold the seat with the other hand, and push the handlebar and the seat towards each other.

## HOW TO ADJUST THE PEDALING RESISTANCE

To increase the resistance of the pedals, turn the resistance knob clockwise; to decrease the resistance, turn the knob counterclockwise. **IMPORTANT: Stop turning the knob when turning becomes difficult, or you may damage the exercise bike.**

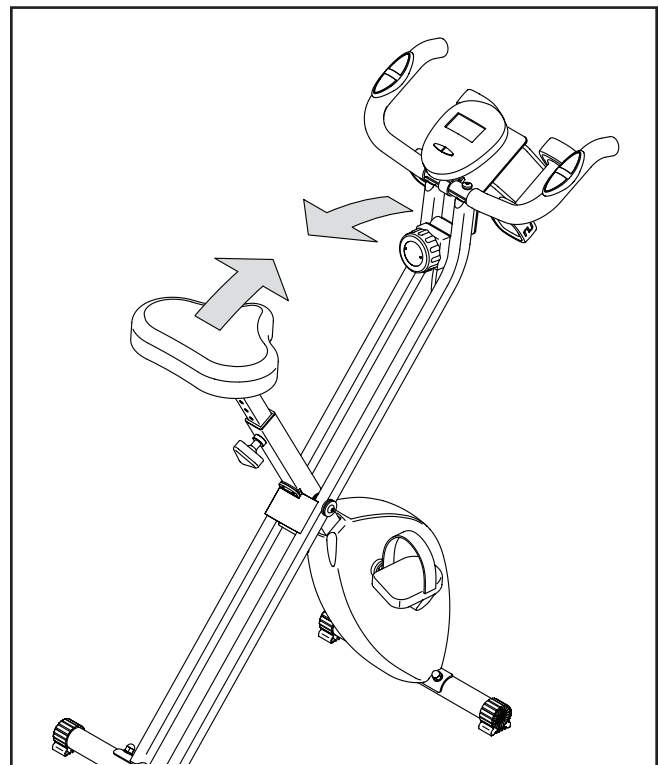
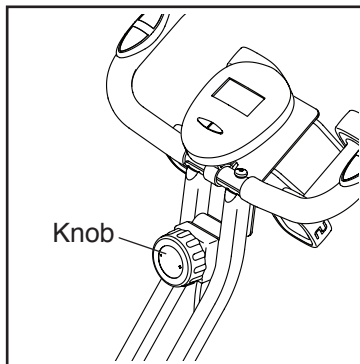

## FEATURES OF THE CONSOLE

The easy-to-use console features six modes that provide instant exercise feedback during your workouts. The modes are described below.



**Scan**—This mode displays the time, speed, distance, calories, and pulse modes, for a few seconds each, in a repeating cycle.

**Time**—This mode displays the elapsed time that you have pedaled during your workout.

**Speed (SPD)**—This mode displays your pedaling speed, in kilometers per hour.

**Distance (DIST)**—This mode displays the distance that you have pedaled during your workout, in kilometers.

**Calories (CAL)**—This mode displays the approximate number of calories that you have burned during your workout.

**Pulse (PUL)**—This mode displays your heart rate in beats per minute when you are using the heart rate monitor (see step 3 on page 13). When your pulse is not detected, a P will appear in the display.

## HOW TO USE THE CONSOLE

Make sure that there are batteries (not included) in the console (see assembly step 8 on page 9). If there is a sheet of clear plastic on the display, remove the plastic.

### 1. Turn on the console.

To turn on the console, press either button on the console or simply begin pedaling.

### 2. Select one of the six modes:

#### Scan mode—

When the console is turned on, the scan mode will automatically be selected. One mode arrow will point to the word SCAN, and a second mode arrow will show which mode is currently displayed. Note: If a different mode is selected, select the scan mode again by repeatedly pressing the Mode button.

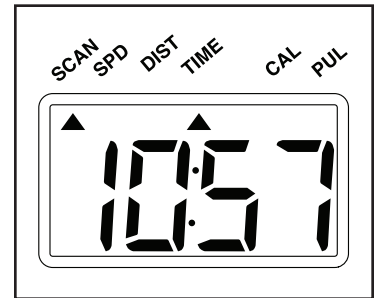

#### Time, speed, distance, calories, or pulse mode—

To select one of these modes for continuous display, press the Mode button repeatedly. The mode arrows will show which mode is selected. **Make sure that there is not a mode arrow pointing to the word SCAN.**

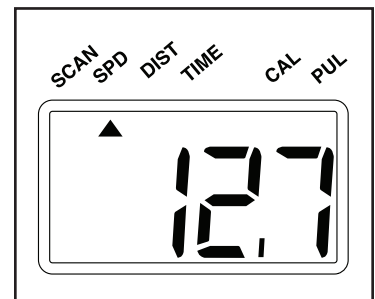

### 3. Measure your heart rate, if desired.

If there are sheets of plastic on the metal contacts of the handgrip heart rate monitor, remove the plastic. Place your hands on the handgrip heart rate monitor, with your

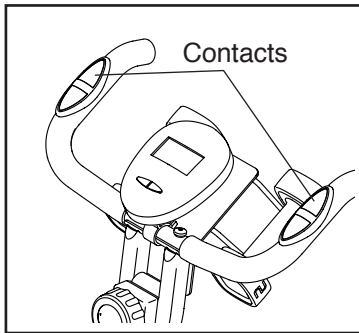

palms on the contacts. Avoid moving your hands. When your pulse is detected, your heart rate will be shown when the pulse mode is displayed. **For the most accurate heart rate reading, continue to hold the handgrips for about 15 seconds.**

If your heart rate is not shown, make sure that the pulse mode is displayed. In addition, make sure that your hands are positioned as described and that you are not moving your hands excessively or squeezing the contacts tightly. For optimal performance, periodically clean the contacts using a soft cloth; **never use alcohol, abrasives, or chemicals to clean the contacts.**

### 4. Reset the console, if desired.

To reset the console, hold down the Reset button for a few seconds. After the console is reset, the scan mode will be selected.

### 5. When you are finished exercising, the console will turn off automatically.

If the pedals are not moved for a few seconds, the console will pause.

**The console has an auto-off feature. If the pedals are not moved and the console buttons are not pressed for a few minutes, the console will turn off automatically to save the batteries.**

---

## FCC INFORMATION

This equipment has been tested and found to comply with the limits for a Class B digital device, pursuant to part 15 of the FCC Rules. These limits are designed to provide reasonable protection against harmful interference in a residential installation. This equipment generates, uses, and can radiate radio frequency energy and, if not installed and used in accordance with the instructions, may cause harmful interference to radio communications. However, there is no guarantee that interference will not occur in a particular installation. If this equipment does cause harmful interference to radio or television reception, which can be determined by turning the equipment off and on, try to correct the interference by one or more of the following measures:

- Reorient or relocate the receiving antenna.
- Increase the separation between the equipment and the receiver.
- Connect the equipment into an outlet on a circuit different from that to which the receiver is connected.
- Consult the dealer or an experienced radio/TV technician for help.

**FCC CAUTION: To assure continued compliance, use only shielded interface cables when connecting to computer or peripheral devices. Changes or modifications not expressly approved by the party responsible for compliance could void the user's authority to operate this equipment.**

---

## MAINTENANCE AND TROUBLESHOOTING

### MAINTENANCE

Inspect and tighten all parts of the exercise bike regularly. Replace any worn parts immediately.

To clean the exercise bike, use a damp cloth and a small amount of mild detergent. **IMPORTANT: To avoid damage to the console, keep liquids away from the console and keep the console out of direct sunlight.**

### CONSOLE TROUBLESHOOTING

If the console display becomes dim, replace the batteries (see assembly step 8 on page 9); most console problems are the result of low batteries.

If the heart rate monitor does not function properly, see step 3 on page 13.

### HOW TO ADJUST THE REED SWITCH

If the console does not display correct feedback, the reed switch should be adjusted. Before adjusting the reed switch, turn the resistance knob to the lowest setting.

Next, loosen the screws (not shown) in the Shields (26, 27), and carefully remove the Shield Cover (28).

Locate the Reed Switch (29), and slide it upward or downward slightly. Then, turn the pedals for a moment and see whether the console displays correct feedback. Repeat this step until the console displays correct feedback.

When the console displays correct feedback, reattach the Shield Cover (28).

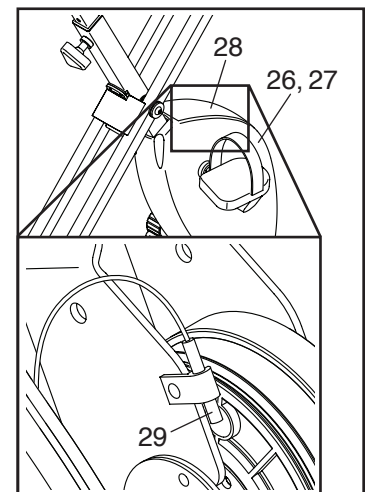

# EXERCISE GUIDELINES

**⚠️ WARNING:** Before beginning this or any exercise program, consult your physician. This is especially important for persons over age 35 or persons with pre-existing health problems.

The heart rate monitor is not a medical device. Various factors may affect the accuracy of heart rate readings. The heart rate monitor is intended only as an exercise aid in determining heart rate trends in general.

These guidelines will help you to plan your exercise program. For detailed exercise information, obtain a reputable book or consult your physician. Remember, proper nutrition and adequate rest are essential for successful results.

## EXERCISE INTENSITY

Whether your goal is to burn fat or to strengthen your cardiovascular system, exercising at the proper intensity is the key to achieving results. You can use your heart rate as a guide to find the proper intensity level. The chart below shows recommended heart rates for fat burning and aerobic exercise.

165	155	145	140	130	125	115	❤️
145	138	130	125	118	110	103	❤️
125	120	115	110	105	95	90	❤️
<hr/>							
20	30	40	50	60	70	80	

To find the proper intensity level, find your age at the bottom of the chart (ages are rounded off to the nearest ten years). The three numbers listed above your age define your “training zone.” The lowest number is the heart rate for fat burning, the middle number is the heart rate for maximum fat burning, and the highest number is the heart rate for aerobic exercise.

**Burning Fat**—To burn fat effectively, you must exercise at a low intensity level for a sustained period of time. During the first few minutes of exercise, your body uses carbohydrate calories for energy. Only after the first few minutes of exercise does your body begin to use stored fat calories for energy. If your goal is to burn fat, adjust the intensity of your exercise until your heart rate is near the lowest number in your training zone. For maximum fat burning, exercise with your heart rate near the middle number in your training zone.

**Aerobic Exercise**—If your goal is to strengthen your cardiovascular system, you must perform aerobic exercise, which is activity that requires large amounts of oxygen for prolonged periods of time. For aerobic exercise, adjust the intensity of your exercise until your heart rate is near the highest number in your training zone.

## WORKOUT GUIDELINES

**Warming Up**—Start with 5 to 10 minutes of stretching and light exercise. A warm-up increases your body temperature, heart rate, and circulation in preparation for exercise.

**Training Zone Exercise**—Exercise for 20 to 30 minutes with your heart rate in your training zone. (During the first few weeks of your exercise program, do not keep your heart rate in your training zone for longer than 20 minutes.) Breathe regularly and deeply as you exercise; never hold your breath.

**Cooling Down**—Finish with 5 to 10 minutes of stretching. Stretching increases the flexibility of your muscles and helps to prevent post-exercise problems.

## EXERCISE FREQUENCY

To maintain or improve your condition, complete three workouts each week, with at least one day of rest between workouts. After a few months of regular exercise, you may complete up to five workouts each week, if desired. Remember, the key to success is to make exercise a regular and enjoyable part of your everyday life.

---

# ORDERING REPLACEMENT PARTS

For information about available replacement parts, see the front cover of this manual. To help us assist you, be prepared to provide the following information when contacting us:

- the model number and serial number of the product (see the front cover of this manual)
- the name of the product (see the front cover of this manual)
- the key number and description of the replacement part(s) (see ASSEMBLY on pages 7 through 10)

## LIMITED WARRANTY

**IMPORTANT: To protect your fitness equipment with an extended service plan, see page 4.**

ICON Health & Fitness, Inc. (ICON) warrants this product to be free from defects in workmanship and material, under normal use and service conditions. The frame is warranted for five (5) years from the date of purchase. Parts and labor are warranted for ninety (90) days from the date of purchase.

This warranty extends only to the original purchaser (customer). ICON's obligation under this warranty is limited to repairing or replacing, at ICON's option, the product through one of its authorized service centers. All repairs for which warranty claims are made must be preauthorized by ICON. If the product is shipped to a service center, freight charges to and from the service center will be the customer's responsibility. If replacement parts are shipped while the product is under warranty, the customer will be responsible for a minimal handling charge. For in-home service, the customer will be responsible for a minimal trip charge. This warranty does not extend to freight damage to the product. This warranty will automatically be voided if the product is used as a store display model, if the product is purchased or transported outside the USA, if all instructions in this manual are not followed, if the product is abused or improperly or abnormally used, or if the product is used for commercial or rental purposes. No other warranty beyond that specifically set forth above is authorized by ICON.

ICON is not responsible or liable for indirect, special, or consequential damages arising out of or in connection with the use or performance of the product; damages with respect to any economic loss, loss of property, loss of revenues or profits, loss of enjoyment or use, or costs of removal or installation; or other consequential damages of any kind. Some states do not allow the exclusion or limitation of incidental or consequential damages. Accordingly, the above limitation may not apply to the customer.

The warranty extended hereunder is in lieu of any and all other warranties, and any implied warranties of merchantability or fitness for a particular purpose are limited in their scope and duration to the terms set forth herein. Some states do not allow limitations on how long an implied warranty lasts. Accordingly, the above limitation may not apply to the customer.

This warranty provides specific legal rights; the customer may have other rights that vary from state to state.

**ICON Health & Fitness, Inc., 1500 S. 1000 W., Logan, UT 84321-9813**