

# PRO·FORM<sup>®</sup>

# CROSS WALK<sup>®</sup> si

Model No. PFTL20462

Serial No. \_\_\_\_\_

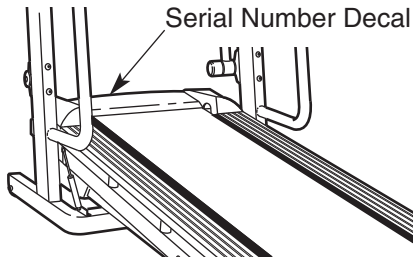

## QUESTIONS?

As a manufacturer, we are committed to providing complete customer satisfaction. If you have questions, or find that there are missing or damaged parts, we will guarantee you complete satisfaction through direct assistance from our factory.

TO AVOID UNNECESSARY DELAYS, PLEASE CALL DIRECT TO OUR TOLL-FREE CUSTOMER HOT LINE. The trained technicians on our Customer Hot Line will provide immediate assistance, free of charge to you.

CUSTOMER HOT LINE:

**1-800-999-3756**

Mon.–Fri., 6 a.m.–6 p.m. MST

## CAUTION

Read all precautions and instructions in this manual before using this equipment. Save this manual for future reference.

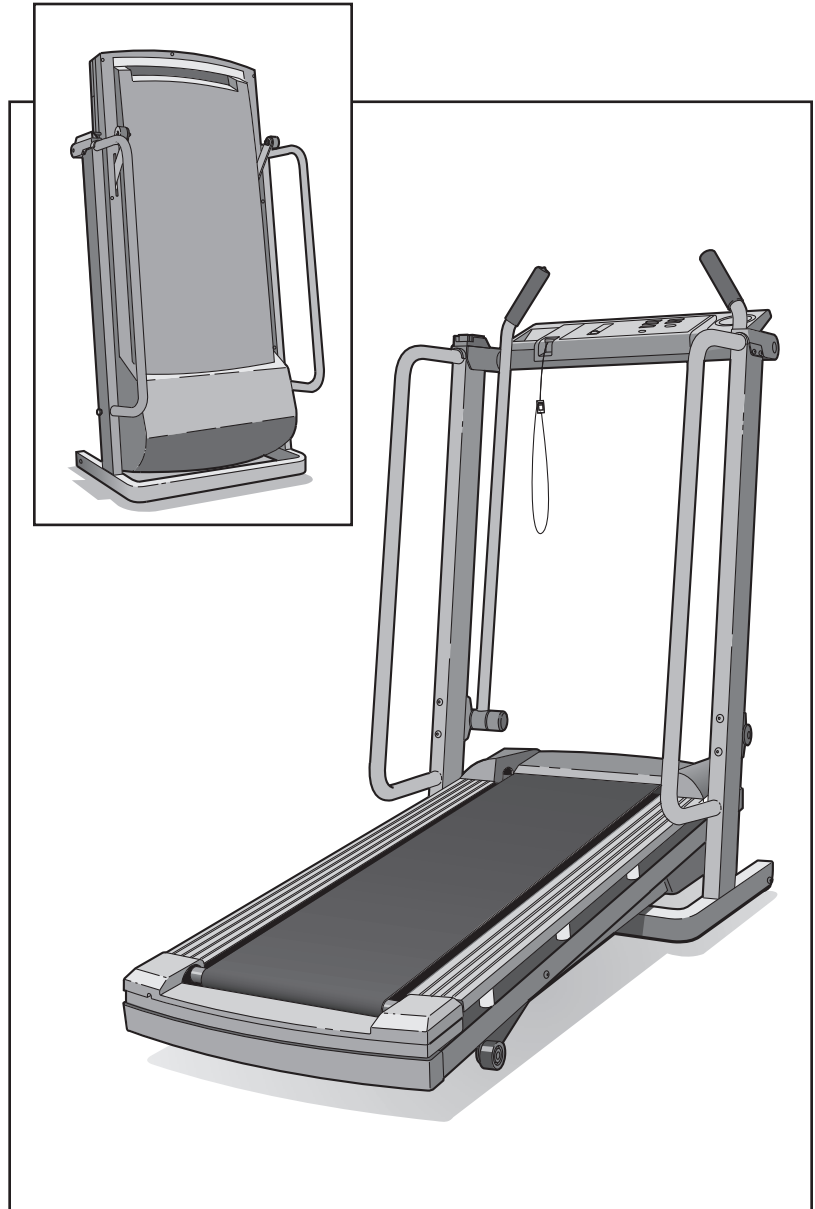

# USER'S MANUAL

# PRO·FORM<sup>®</sup> CROSS WALK<sup>®</sup> si

---

## TABLE OF CONTENTS

IMPORTANT PRECAUTIONS .....	3
BEFORE YOU BEGIN .....	4
ASSEMBLY .....	5
OPERATION AND ADJUSTMENT .....	7
HOW TO FOLD AND MOVE THE TREADMILL .....	10
TROUBLE-SHOOTING .....	12
CONDITIONING GUIDELINES .....	14
ORDERING REPLACEMENT PARTS .....	Back Cover
LIMITED WARRANTY .....	Back Cover

Note: An EXPLODED DRAWING and a PART LIST are attached to the center of this manual. Save the EXPLODED DRAWING and PART LIST for future reference.

**⚠️ WARNING:** Before beginning this or any exercise program, consult your physician. This is especially important for persons over the age of 35 or persons with pre-existing health problems. Read all instructions before using. ICON assumes no responsibility for personal injury or property damage sustained by or through the use of this product.

# IMPORTANT PRECAUTIONS

**⚠️ WARNING:** To reduce the risk of burns, fire, electric shock or injury to persons, read the following important precautions and information before operating the treadmill.

1. It is the responsibility of the owner to ensure that all users of this treadmill are adequately informed of all warnings and precautions.
2. Use the treadmill only as described in this manual.
3. Place the treadmill on a level surface, with eight feet of clearance behind it. Do not place the treadmill on any surface that blocks air openings. To protect the floor or carpet from damage, place a mat under the treadmill.
4. Keep the treadmill indoors, away from moisture and dust. Do not put the treadmill in a garage or covered patio, or near water.
5. Do not operate the treadmill where aerosol products are used or where oxygen is being administered.
6. Keep small children and pets away from the treadmill at all times.
7. The treadmill should be used only by persons weighing 250 pounds or less. Do not allow more than one person on the treadmill at a time.
8. Wear appropriate exercise attire when using the treadmill. Do not wear loose clothing that could become caught in the treadmill. Athletic support clothes are recommended for both men and women. *Always wear athletic shoes. Never use the treadmill with bare feet, wearing only stockings, or in sandals.*
9. When connecting the power cord (see HOW TO PLUG IN THE POWER CORD on page 7), plug the power cord into a surge protector (not included) and plug the surge protector into a grounded circuit capable of carrying 15 or more amps. No other appliance should be on the same circuit.
10. Use only a UL-listed surge protector, rated at 15 amps, with a 14-gauge cord of five feet or less in length. Do not use an extension cord.
11. Never move the walking belt while the power is turned off. Do not operate the treadmill if the power cord or plug is damaged, or if the treadmill is not working properly. (See BEFORE YOU BEGIN on page 4 if the treadmill is not working properly.)
12. Keep the power cord and the surge protector away from heated surfaces.
13. Never start the treadmill while you are standing on the walking belt. Always hold the handrails or upper body arms while using the treadmill.
14. The treadmill is capable of high speeds. Adjust the speed in small increments to avoid sudden jumps in speed.
15. To reduce the possibility of the treadmill overheating, do not operate the treadmill continuously for longer than 1 hour.
16. The pulse sensor is not a medical device. Various factors, including the user's movement, may affect the accuracy of heart rate readings. The pulse sensor is intended only as an exercise aid in determining heart rate trends in general.
17. Never leave the treadmill unattended while it is running. Always remove the key when the treadmill is not in use.
18. You must be able to safely lift 45 pounds (20 kg) to raise, lower, or move the treadmill.
19. When storing or moving the treadmill, make sure that the storage latch is fully closed.
20. Inspect and tighten all parts of the treadmill every three months.
21. Never insert any object into any opening.
22. Always unplug the power cord before performing the maintenance and adjustment procedures described in this manual. Never remove the motor hood unless instructed to do so by an authorized service representative. Servicing other than the procedures in this manual should be performed by an authorized service representative only.

**SAVE THESE INSTRUCTIONS**

# BEFORE YOU BEGIN

Thank you for selecting the PROFORM® CROSS-WALK si treadmill. The CROSSWALK si treadmill combines advanced technology with innovative design to offer you an excellent form of cardiovascular exercise, in the convenience and privacy of your home. And when you're not exercising, the unique CROSS-WALK si can be folded up, requiring less than half the floor space of other treadmills.

**For your benefit, read this manual carefully before using the treadmill.** If you have additional questions,

please call our Customer Service Department toll-free at 1-800-999-3756, Monday through Friday, 6 a.m. until 6 p.m. Mountain Time (excluding holidays). To help us assist you, please note the product model number and serial number before calling. The model number of the treadmill is PFTL20462. The serial number can be found on a decal attached to the treadmill (see the front cover of this manual for the location).

Before reading further, please review the drawing below and familiarize yourself with the labeled parts.

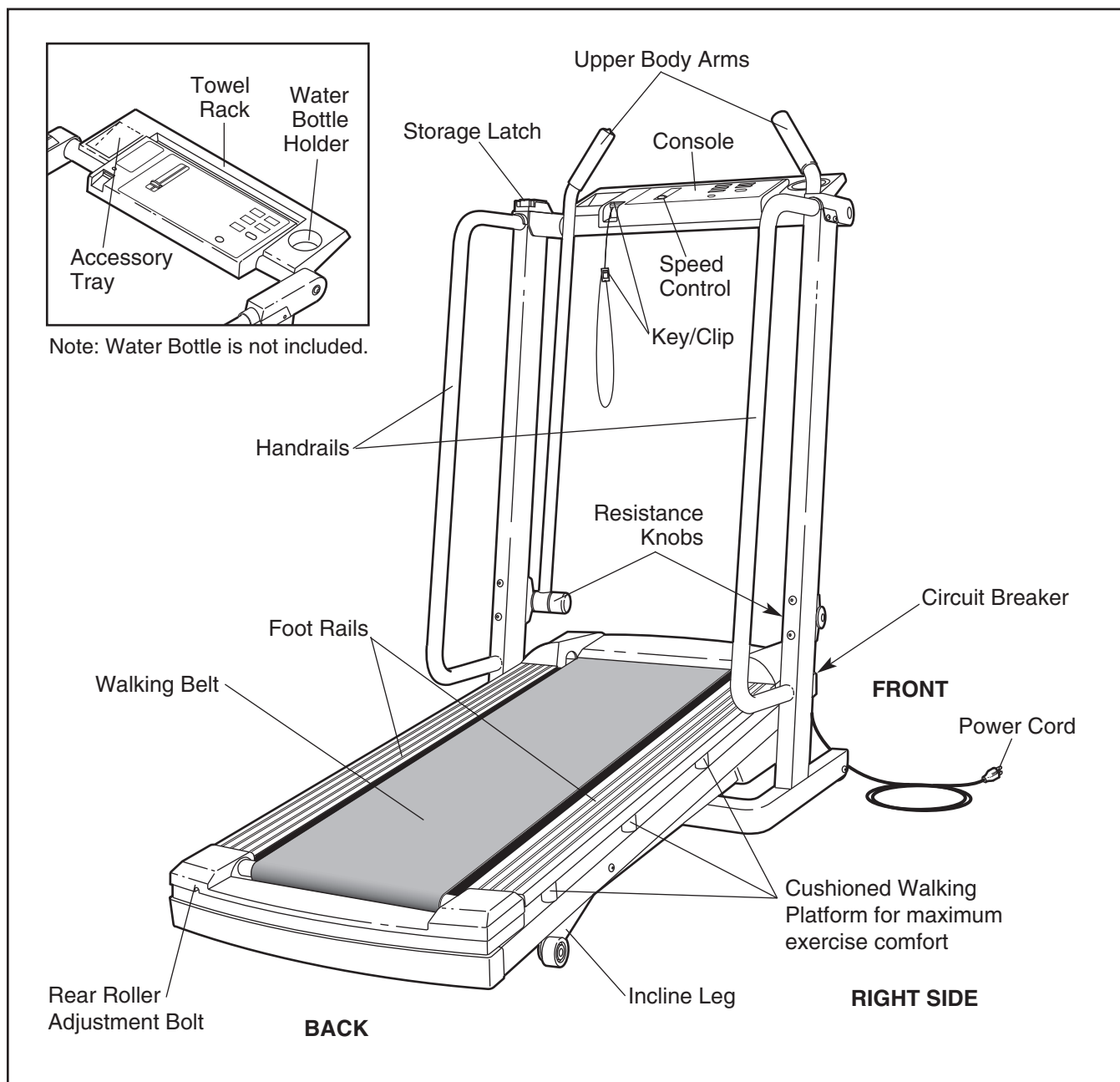

# ASSEMBLY

**Assembly requires two people.** Set the treadmill in a cleared area and remove all packing materials. Do not dispose of the packing materials until assembly is completed. **Tools required for assembly: The included allen wrench and your phillips screwdriver and two adjustable wrenches** .

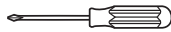

1. Attach six Base Pads (73) to the bottom of the Base (75) in the indicated locations (see the inset drawing). Note: One additional Base Pad will be used in assembly step 6, and one extra Base Pad is included.

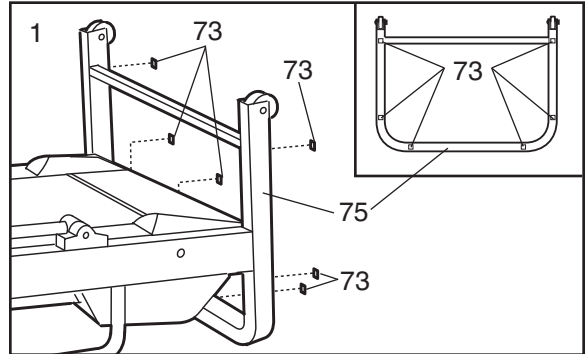

2. Firmly hold the Uprights (11) as shown. Raise the Uprights until the Base (75) and the front Wheels (74) are resting on the floor.

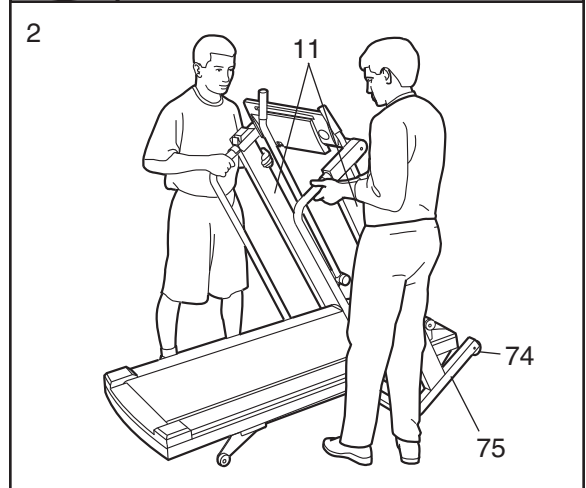

3. Loosen the Crossbar Bolts (2) in the ends of the Console Crossbar (17). Pivot the Console (6) to the angle shown. Look under the Left and Right Crossbar Brackets (4, 51) and find the two small holes in each end of the Console Crossbar (17). Tighten Crossbar Screws (9) into all four holes.

Rotate the Console (6) upward until it stops. Using the 7/32" end of the Allen Wrench (57), tighten the Crossbar Bolts (2) in the ends of the Console Crossbar (17).

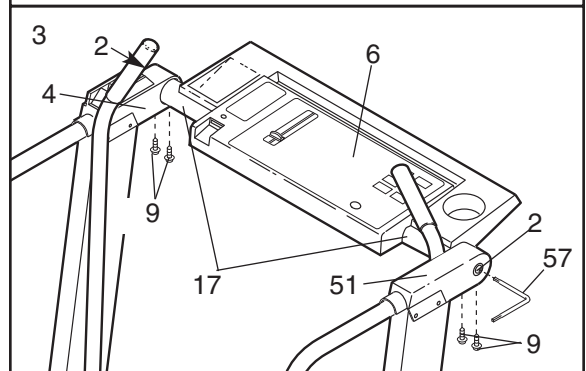

4. Next, the treadmill should be raised to the storage position. Hold the treadmill with your hands in the locations shown at the right. **To decrease the possibility of injury, bend your legs and keep your back straight. As you raise the treadmill, make sure to lift with your legs rather than your back.** Raise the treadmill about halfway to the vertical position.

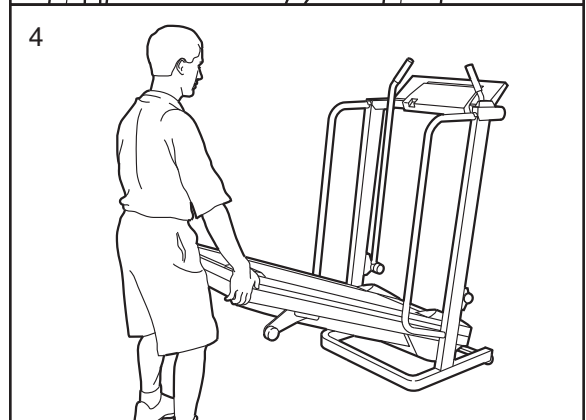

5. Move your right hand to the position shown at the right, and hold the treadmill firmly. Using your left hand, lift the storage latch. Raise the treadmill until the locking pin snaps into the storage latch. **Make sure that the locking pin is inside the storage latch, and that the storage latch is fully closed.**

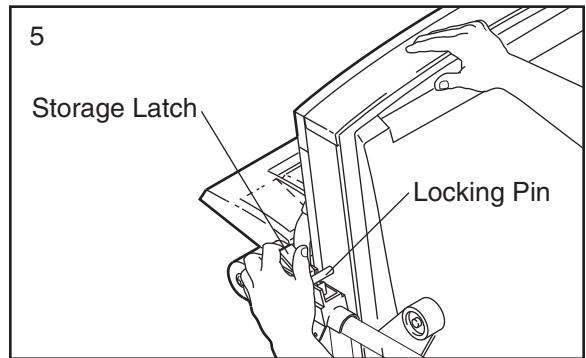

6. See drawing 6B. Attach a Base Pad (73) to the bottom of the Stabilizer Plate (88) in the indicated location.

See drawing 6A. Stand behind the treadmill. Hold the Left Crossbar Bracket (4) and the Right Crossbar Bracket (not shown). Place one foot on the Base (75) in the indicated location. Tip the treadmill back slightly. While the treadmill is held in this position, a second person should slide the Stabilizer Plate (88) onto the Base (see drawing 6C). Keeping your foot on the Base, carefully tip the treadmill up until it is resting on the Base. Make sure that the Stabilizer Plate (88) stays on the Base.

See drawing 6C. Attach the Stabilizer Plate (88) to the Base (75) with a Stabilizer Plate Bolt (105), two Washers (72), and the Stabilizer Plate Nut (95) as shown.

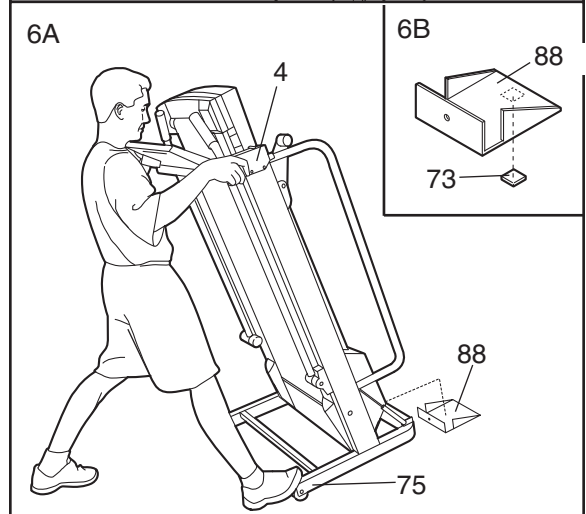

7. Refer to assembly drawing 5 at the top of this page. Hold the upper end of the treadmill with your right hand as shown. Using your left hand, lift the storage latch. Pivot the treadmill slightly until the locking pin is out of the storage latch.

Hold the treadmill firmly with both hands, and lower the treadmill to the floor. **To decrease the possibility of injury, bend your legs and keep your back straight.**

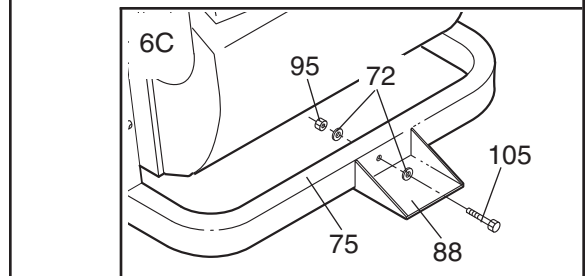

8. Remove the paper backing from the Adhesive Clip (44). Press the Adhesive Clip onto the Frame (56) in the indicated location. Press the Allen Wrench (57) into the Adhesive Clip. The use of the Allen Wrench is described on page 12.

Make sure that all parts are tightened before you use the treadmill. **Note: To protect the floor or carpet, place a mat under the treadmill.**

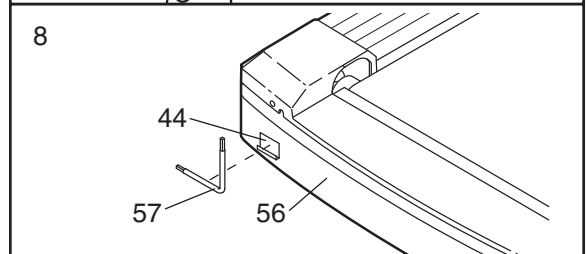
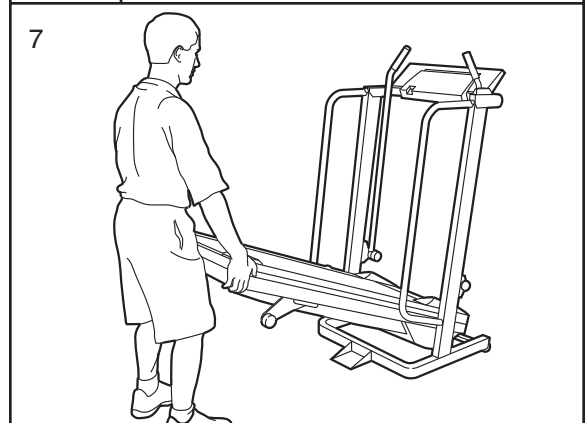

# OPERATION AND ADJUSTMENT

## THE PERFORMANT LUBE™ WALKING BELT

Your treadmill features a walking belt coated with PERFORMANT LUBE™, a high-performance lubricant. **IMPORTANT: Never apply silicone spray or other substances to the walking belt or the walking platform. They will deteriorate the walking belt and cause excessive wear.**

## HOW TO PLUG IN THE POWER CORD

**⚠ DANGER:** Improper connection of the equipment-grounding conductor can result in an increased risk of electric shock. Check with a qualified electrician or serviceman if you are in doubt as to whether the product is properly grounded. Do not modify the plug provided with the product—if it will not fit the outlet, have a proper outlet installed by a qualified electrician.

Your treadmill, like any other type of sophisticated electronic equipment, can be seriously damaged by sudden voltage changes in your home's power. Voltage surges, spikes, and noise interference can result from weather conditions or from other appliances being turned on or off.

**To decrease the possibility of your treadmill being damaged, always use a surge protector (not included) with your treadmill.**

Surge protectors are sold at most hardware stores and department stores. Use only a UL-listed surge protector, rated at 15 amps, with a 14-gauge cord of five feet or less in length.

**This product must be grounded.** If it should malfunction or break down, grounding provides a path of least resistance for electric current to reduce the risk

of electric shock. This product is equipped with a cord having an equipment-grounding conductor and a grounding plug. **Plug the power cord into a surge protector, and plug the surge protector into an appropriate outlet that is properly installed and grounded in accordance with all local codes and ordinances.**

This product is for use on a nominal 120-volt circuit, and has a grounding plug that looks like the plug illustrated in drawing 1 below. A temporary adapter that looks like the adapter illustrated in drawing 2 may be used to connect the surge protector to a 2-pole receptacle as shown in drawing 2 if a properly grounded outlet is not available.

The temporary adapter should be used only until a properly grounded outlet (drawing 1) can be installed by a qualified electrician.

The green-colored rigid ear, lug, or the like extending from the adapter must be connected to a permanent ground such as a properly grounded outlet box cover. Whenever the adapter is used it must be held in place by a metal screw. **Some 2-pole receptacle outlet box covers are not grounded. Contact a qualified electrician to determine if the outlet box cover is grounded before using an adapter.**

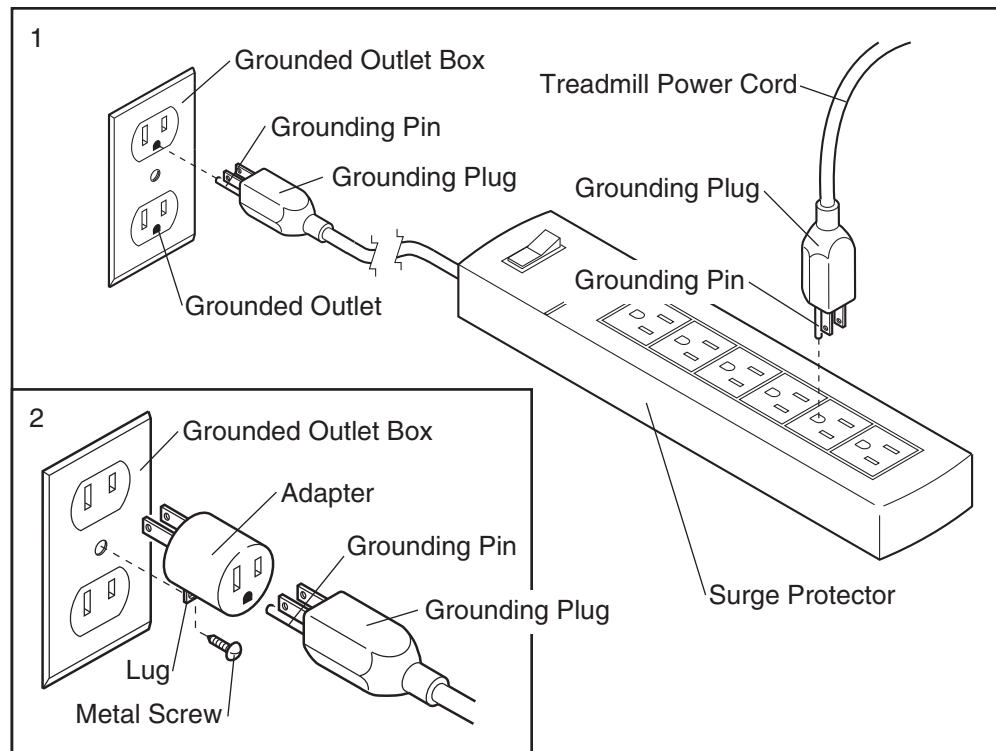

## DIAGRAM OF THE CONSOLE

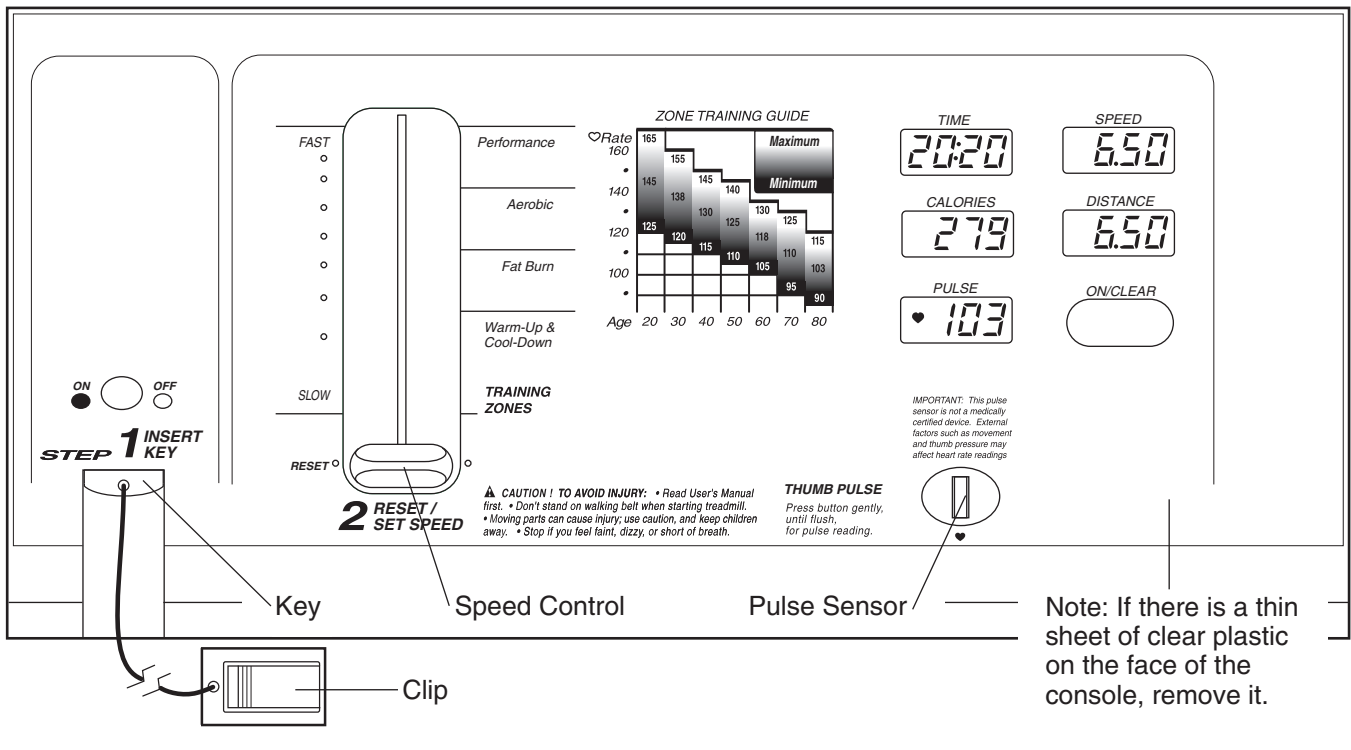

### ⚠ CAUTION: Before operating the console, read the following precautions.

- Do not stand on the walking belt when turning on the power.
- Always wear the clip (see the drawing above) while operating the treadmill. When the key is removed from the console, the walking belt will stop.
- Adjust the speed in small increments until you are familiar with the treadmill.
- The training zones marked beside the speed control are general guidelines only. See pages 14 and 15 for more information.
- To reduce the possibility of electric shock, keep the console dry. Avoid spilling liquids on the console, and use only a sealed water bottle.

Press two batteries into the battery compartment, with the negative (-) ends of the batteries touching the springs. Close the battery cover.

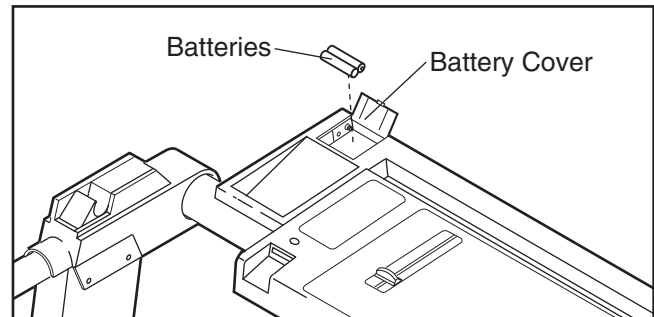

Next, step onto the foot rails of the treadmill. Find the clip attached to the key (see the drawing at the top of this page), and slide the clip onto the waistband of your clothing.

Follow the steps below and on page 9 to operate the console.

## STEP BY STEP CONSOLE OPERATION

Before operating the console, make sure that the power cord is properly plugged in. (See HOW TO PLUG IN THE POWER CORD on page 7.)

The console requires **two "AA" batteries** (not included); alkaline batteries are recommended. Open the battery cover as shown in the drawing at the upper right.

### 1 Insert the key fully into the power switch.

Inserting the key will not turn on the displays. The displays will turn on when the ON/CLEAR button is pressed or the walking belt is started.  
Note: If you just installed batteries, the displays will already be on.

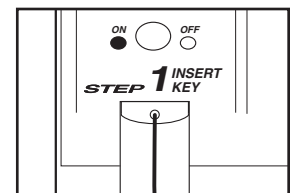

## 2 Reset the speed control and start the walking belt.

Slide the speed control down to the "RESET" position.

**Note: Each time the walking belt is stopped, the speed control must be moved to the "RESET" position before the walking belt can be restarted.**

Next, slide the control up until the walking belt begins to move at slow speed.

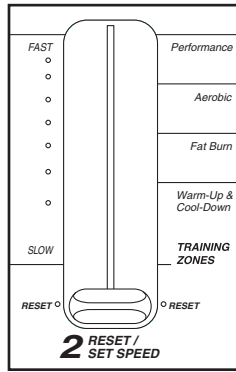

Carefully step onto the walking belt and begin exercising. Change the speed of the walking belt as desired by sliding the speed control. To stop the walking belt, step onto the foot rails and slide the speed control to the "RESET" position.

## 3 Follow your progress with the monitor displays.

### • TIME

This display shows the total length of time that you have exercised. When the walking belt is stopped, the TIME display will pause after a few seconds.



### • SPEED

This display shows the current speed of the walking belt.



### • CALORIES

This display shows the approximate number of Calories you have burned. Note: The actual number of Calories you have burned may differ slightly from the number shown, depending on the speed and incline of the treadmill.



### • DISTANCE

This display shows the total distance you have walked or run.



The displays can be reset, if desired, by pressing the ON/CLEAR button.

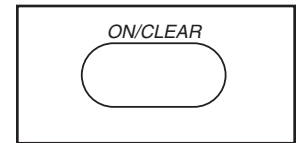

## 4 Measure your pulse, if desired.

To use the pulse sensor, stand on the foot rails and place your thumb on the pulse sensor as shown. The

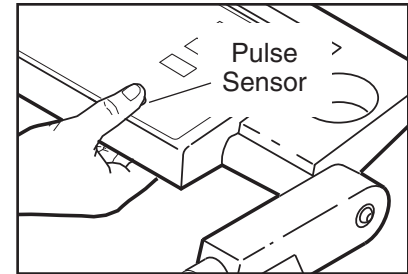

pulse sensor is pressure-activated. Fully press down the pulse sensor. **Do not press too hard, or the circulation in your thumb will be restricted, and your pulse will not be detected.** Next, slightly raise your thumb until the heart-shaped indicator in the PULSE display flashes **steadily**. Hold your thumb at this level. After 5 to 10 seconds, your pulse will be shown in the PULSE display. Hold your thumb on the sensor for another 15 seconds for the most accurate reading. If the displayed pulse appears to be too high or too low, or if your pulse is not displayed, lift your thumb off the sensor and allow the display to reset. Press down again on the sensor as described above.

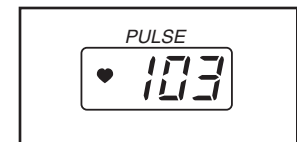

Make sure that your thumb is positioned as shown, and that you are applying the proper amount of pressure to the pulse sensor. Try the sensor several times until you become familiar with it. Remember to stand still while measuring your pulse.

## 5 When you are finished exercising, stop the walking belt and remove the key.

Step onto the foot rails, stop the walking belt, and remove the key from the console. Store the key in a secure place.

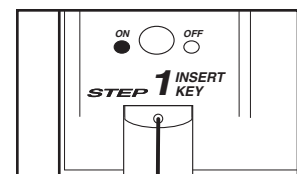

**Note: After the key is removed, the displays will remain on for about four minutes.**

## HOW TO USE THE UPPER BODY ARMS

As you exercise on the treadmill, you can hold either the handrails or the upper body arms. The upper body arms are designed to exercise your arms, shoulders, and back for a total body workout. Hold one upper body arm with each hand, and move the arms forward and back as you walk on the treadmill.

To vary the intensity of your upper body exercise, the resistance of the upper body arms can be adjusted. To increase the resistance, turn the resistance knobs clockwise; to decrease the resistance, turn the knobs counterclockwise.

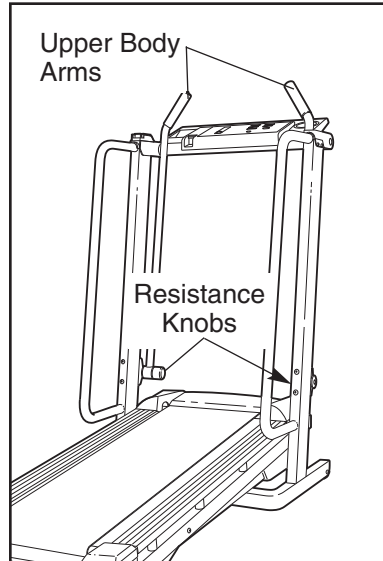

## HOW TO CHANGE THE INCLINE OF THE TREADMILL

The incline of the treadmill can be changed by raising or lowering the back end. **Before changing the incline, remove the key and unplug the power cord.**

Hold the back end of the treadmill frame with both hands. When the back end of the treadmill is in the lowest position, the incline is about 10%. Raise the back end until both incline legs click into position. The incline will then be about 5%. Raise the back end again until the incline legs click into position. The incline will then be about 3%. To lower the back end, first raise it past the highest position, and then lower it. **CAUTION: Before exercising, push on the back of the treadmill to make sure that the incline legs are locked in position. Both incline legs must be at the same level.**

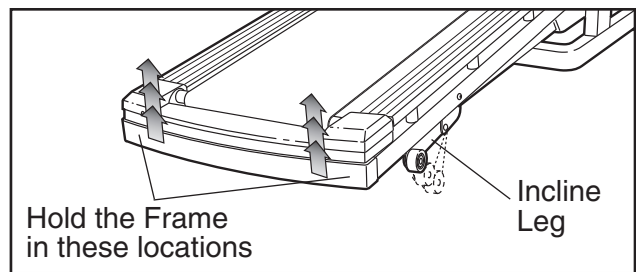

## HOW TO FOLD AND MOVE THE TREADMILL

### HOW TO FOLD THE TREADMILL FOR STORAGE

Before folding the treadmill, unplug the power cord.

**Caution: You must be able to safely lift 45 pounds (20 kg) in order to raise, lower, or move the treadmill.**

1. Hold the treadmill, with your hands in the locations shown at the right. **To decrease the possibility of injury, bend your legs and keep your back straight. As you raise the treadmill, make sure to lift with your legs rather than your back.** Raise the treadmill about halfway to the vertical position.

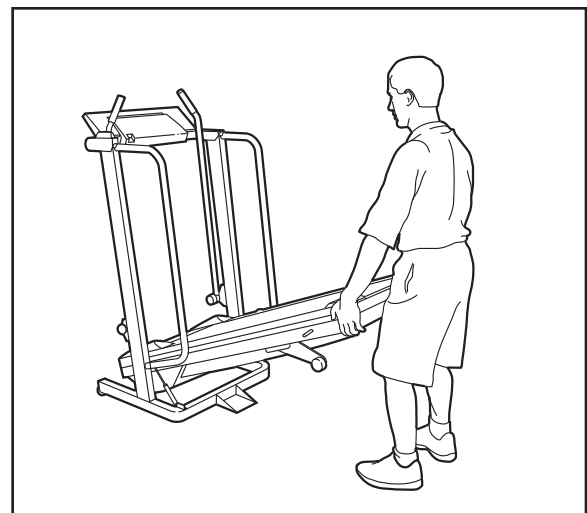

2. Move your right hand to the position shown at the right, and hold the treadmill firmly. Using your left hand, lift the storage latch. Raise the treadmill until the locking pin snaps into the storage latch. **Make sure that the locking pin is inside the storage latch, and that the storage latch is fully closed.**

**To protect the floor or carpet from damage, place a mat under the treadmill. Keep the treadmill out of direct sunlight. Do not leave the treadmill in the storage position in temperatures above 85° Fahrenheit.**

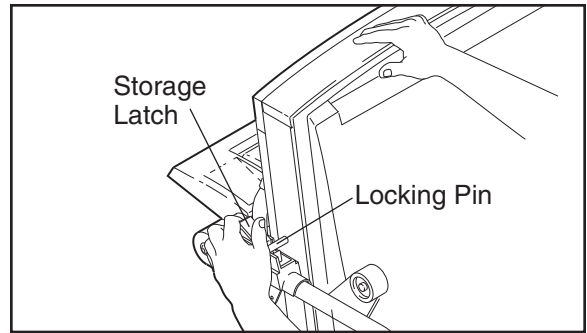

### HOW TO MOVE THE TREADMILL

Before moving the treadmill, convert the treadmill to the storage position as described on pages 10 and 11.

1. **Make sure that the locking pin is inside the storage latch, and that the storage latch is fully closed.**
2. Hold one crossbar bracket with each hand. Place one foot on the base as shown.
3. Tilt the treadmill back until it rolls freely on the front wheels. Carefully move the treadmill to the desired location. **To reduce the risk of injury, use extreme caution while moving the treadmill. Do not attempt to move the treadmill over an uneven surface.**
4. Place one foot on the base, and carefully lower the treadmill until it is resting in the storage position.

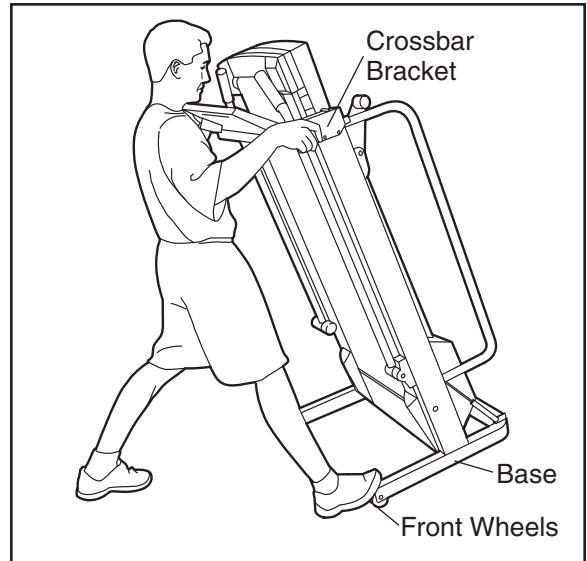

### HOW TO LOWER THE TREADMILL FOR USE

1. Hold the upper end of the treadmill with your right hand as shown. Using your left hand, lift the storage latch. Pivot the treadmill slightly until the locking pin is out of the storage latch.
2. Hold the treadmill firmly with both hands, and lower the treadmill to the floor. **To decrease the possibility of injury, bend your legs and keep your back straight.**

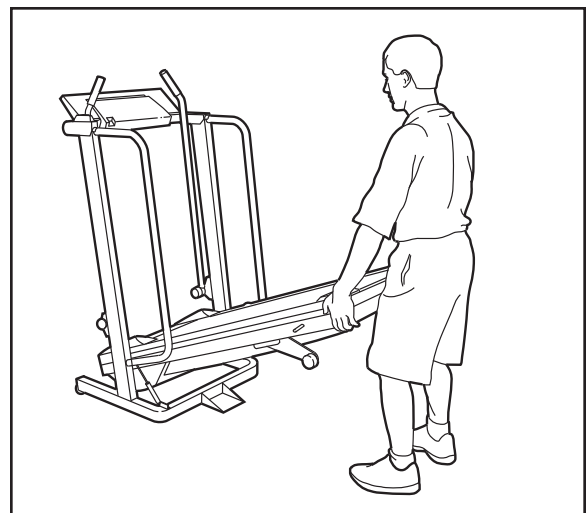
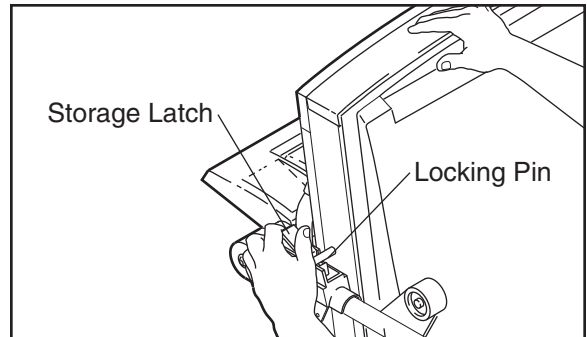

# TROUBLE-SHOOTING

Most treadmill problems can be solved by following the steps below. Find the symptom that applies, and follow the steps listed. If further assistance is needed, please call our Customer Service Department toll-free at 1-800-999-3756, Monday through Friday, 6 a.m. until 6 p.m. Mountain Time (excluding holidays).

## 1. SYMPTOM: THE POWER DOES NOT TURN ON

- Make sure that the power cord is plugged into a surge protector, and that the surge protector is plugged into a properly grounded outlet. (See HOW TO PLUG IN THE POWER CORD on page 7.) Use only a UL-listed surge protector, rated at 15 amps, with a 14-gauge cord of five feet or less in length.
- After the power cord has been plugged in, make sure that the key is fully inserted into the console. (See step 1 on page 8.)
- Check the circuit breaker located on the treadmill near the power cord. If the switch protrudes as shown, the circuit breaker has tripped. To reset the circuit breaker, wait for five minutes and then press the switch back in.

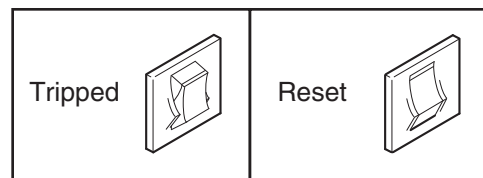

## 2. SYMPTOM: THE POWER TURNS OFF DURING USE

- Check the circuit breaker located on the treadmill frame near the power cord (see 1. c. above). If the circuit breaker has tripped, wait for five minutes and then press the switch back in.
- Make sure that the power cord is plugged in.
- Remove the key from the console. Reinsert the key fully into the console. (See step 1 on page 8.)
- If the treadmill still will not run, please call our toll-free Customer Service Department.

## 3. SYMPTOM: THE WALKING BELT SLOWS WHEN WALKED ON

- Use only a UL-listed surge protector, rated at 15 amps, with a 14-gauge cord of five feet or less in length.
- If the walking belt still slows when walked on, please call our toll-free Customer Service Department.

## 4. SYMPTOM: THE WALKING BELT IS OFF-CENTER WHEN WALKED ON

- If the walking belt has shifted to the left, first remove the key and **UNPLUG THE POWER CORD**. Using the 3/16" end of the allen wrench, turn the left rear roller adjustment bolt clockwise 1/4 of a turn. Plug in the power cord, insert the key and run the treadmill for a few minutes. Repeat until the walking belt is centered.

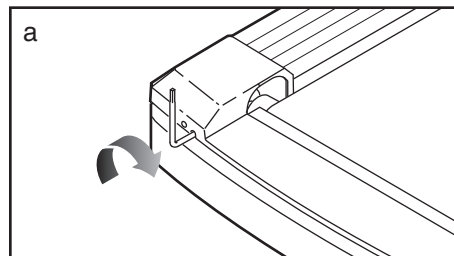

- If the walking belt has shifted to the right, first remove the key and **UNPLUG THE POWER CORD**. Using the 3/16" end of the allen wrench, turn the left rear roller adjustment bolt counter-clockwise 1/4 of a turn. Plug in the power cord, insert the key and run the treadmill for a few minutes. Repeat until the walking belt is centered.

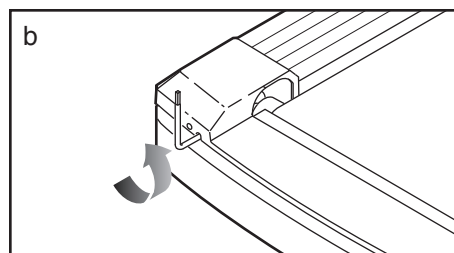

## 5. SYMPTOM: THE DISPLAYS OF THE CONSOLE DO NOT FUNCTION PROPERLY

- a. The console requires two "AA" batteries (not included); alkaline batteries are recommended. If the displays of the console do not function properly, the batteries should be replaced. Open the battery cover as shown at the right. Press two batteries into the battery compartment, with the negative (-) ends of the batteries touching the springs. Close the battery cover.

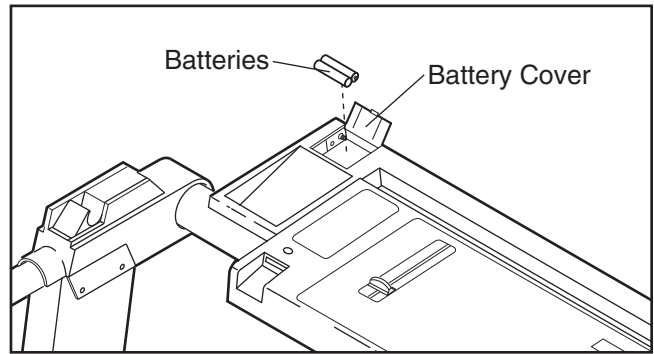

## 6. SYMPTOM: ONE OF THE UPPER BODY ARMS SQUEAKS DURING USE

- a. Correcting this problem requires a small amount of white marine grease, available at most department stores.

Turn the Resistance Knob (59) counterclockwise until it can be removed. Remove the Resistance Cone (60) and the Upper Body Arm (12), along with the 3/8" Flat Washers (65), Spring Washer (62), Thrust Washers (63), and Thrust Bearing (64). (Note: If the Resistance Sleeve [61] comes out of the Resistance Bracket [66], press it back in.) Apply a **thin layer** of white marine grease to the outer surface of the Resistance Cone (60). Reattach all parts in the order shown at the right.

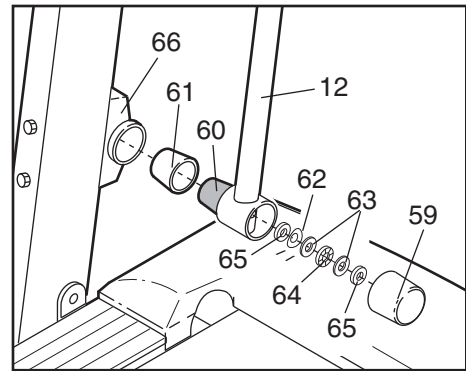

# CONDITIONING GUIDELINES

**⚠ WARNING:** Before beginning this or any exercise program, consult your physician. This is especially important for individuals over the age of 35 or individuals with pre-existing health problems.

The pulse sensor is not a medical device. Various factors, including your movement, may affect the accuracy of heart rate readings. The sensor is intended only as an exercise aid in determining heart rate trends in general.

The following guidelines will help you to plan your exercise program. Remember—these are general guidelines. For more detailed information about exercise, obtain a reputable book or consult your physician.

## EXERCISE INTENSITY

Whether your goal is to burn fat or to strengthen your cardiovascular system, the key to achieving the desired results is to exercise with the proper intensity. The proper intensity level can be found by using your heart rate as a guide.

The chart below shows recommended heart rates for fat burning, aerobic exercise, and high performance athletic conditioning. (This chart is also found on the console.)

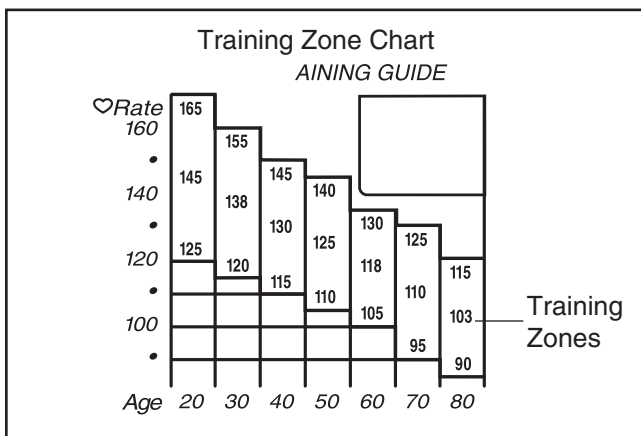

To find the proper heart rate for you, first find your age near the bottom of the chart (ages are rounded off to the nearest ten years). Next, look above your age and find the box containing three numbers. The three numbers are your “training zone.” The lowest number is the recommended heart rate for fat burning; the middle number is the recommended heart rate for aerobic exercise; the highest number is the recommended heart rate for high performance athletic conditioning.

## Fat Burning

To burn fat effectively, you must exercise at a relatively low intensity level for a sustained period of time. During the first few minutes of exercise, your body uses easily accessible *carbohydrate calories* for energy. Only after the first few minutes does your body begin to use stored *fat calories* for energy. If your goal is to burn fat, adjust the speed and incline of the treadmill until your heart rate is near the lowest number in your training zone as you exercise. It may also be helpful to set the speed control on the console to FAT BURN to help you maintain the proper intensity level. (See page 8.)

## Aerobic Exercise

If your goal is to strengthen your cardiovascular system, your exercise must be “aerobic.” Aerobic exercise is activity that requires large amounts of oxygen for prolonged periods of time. This increases the demand on the heart to pump blood to the muscles, and on the lungs to oxygenate the blood. For aerobic exercise, adjust the speed and incline of the treadmill until your heart rate is near the middle number in your training zone. It may also be helpful to set the speed control on the console to AEROBIC to help you maintain the proper intensity level. (See page 8.)

## High Performance Athletic Conditioning

If your goal is high performance athletic conditioning, adjust the speed and incline of the treadmill until your heart rate is near the highest number in your training zone. It may also be helpful to set the speed control on the console to PERFORMANCE to help you maintain the proper intensity level. (See page 8.)

## HOW TO MEASURE YOUR HEART RATE

You can measure your heart rate using the pulse sensor on the console. Exercise for about four minutes, and then measure your heart rate immediately. If your heart rate is too high or too low, adjust the speed and incline of the treadmill until your heart rate is at the proper level.

## WORKOUT GUIDELINES

A well-rounded workout includes three phases:

**A warm-up phase**, lasting 5 to 10 minutes. Begin with slow, controlled stretches, and progress to more rhythmic stretches to increase the body temperature, heart rate and circulation in preparation for strenuous exercise. Stretching also guards against muscle, tendon and ligament sprains.

**A cardiovascular phase**, including 20 to 30 minutes of exercising with your heart rate in your training zone. (See EXERCISE INTENSITY on page 14 to find your training zone.)

**A cool-down phase**, consisting of 5 to 10 minutes of stretching. Thorough stretching offsets muscle contractions and other problems caused when you stop exercising suddenly. Stretching for increased flexibility is also most effective during this phase. This phase should leave you relaxed and comfortably tired.

To maintain or improve your condition, plan three workouts each week, with at least one day of rest between workouts. After a few months of regular exercise, you may complete up to five workouts each week, if desired.

Remember, the key to success is make exercise a regular and enjoyable part of your everyday life.

## SUGGESTED STRETCHES

The correct form for several basic stretches is shown in the drawings below. Move slowly as you stretch—never bounce.

### 1. Toe Touch Stretch

Stand with your knees bent slightly and slowly bend forward from your hips. Allow your back and shoulders to relax as you reach down toward your toes as far as possible. Hold for 15 counts, then relax. Repeat 3 times. Stretches: Hamstrings, back of knees and back.

### 2. Hamstring Stretch

Sit with one leg extended. Bring the sole of the opposite foot toward you and rest it against the inner thigh of your extended leg. Reach toward your toes as far as possible. Hold for 15 counts, then relax. Repeat 3 times for both legs. Stretches: Hamstrings, lower back and groin.

### 3. Calf/Achilles Stretch

With one leg in front of the other, reach forward and place your hands against a wall. Keep your back leg straight and your back foot flat on the floor. Bend your front leg, lean forward and move your hips toward the wall. Hold for 15 counts, then relax. Repeat 3 times for both legs. To cause further stretching of the achilles tendons, bend your back leg as well. Stretches: Calves, achilles tendons and ankles.

### 4. Quadriceps Stretch

With one hand against a wall for balance, reach back and grasp one foot with your other hand. Bring your heel as close to your buttocks as possible. Hold for 15 counts, then relax. Repeat 3 times for both legs. Stretches: Quadriceps and hip muscles.

### 5. Inner Thigh Stretch

Sit with the soles of your feet together and your knees outward. Pull your feet toward your groin area as far as possible. Hold for 15 counts, then relax. Repeat 3 times. Stretches: Quadriceps and hip muscles.

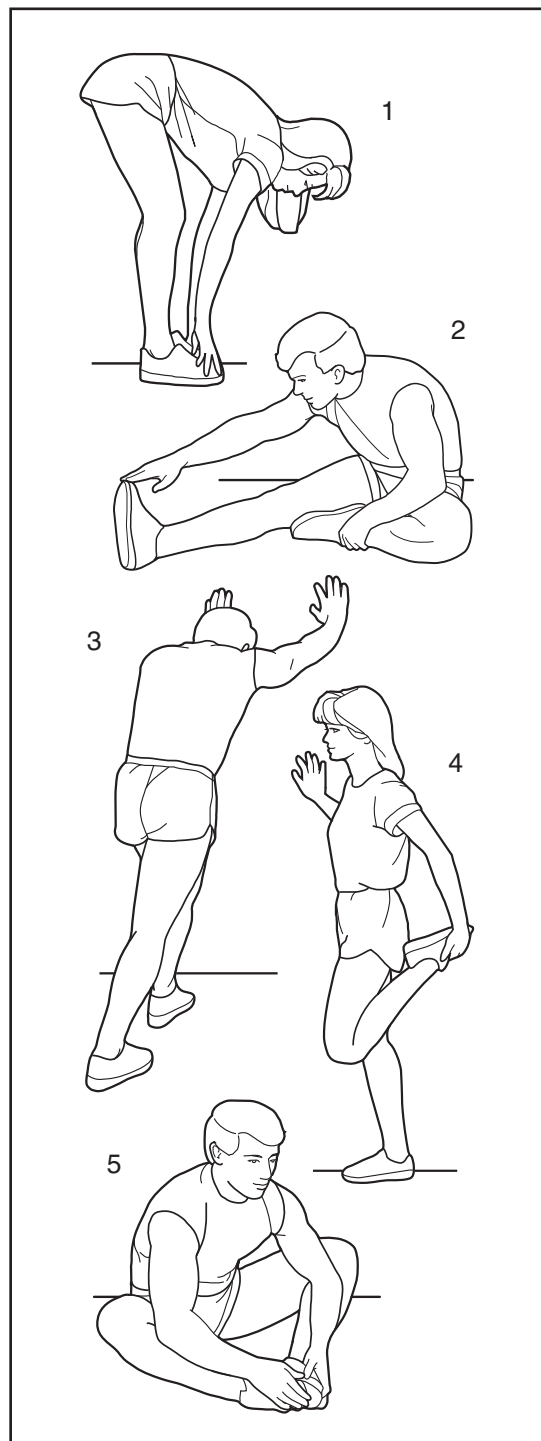

# PART LIST—Model No. PFTL20462

R0496A

Key No.	Qty.	Description	Key No.	Qty.	Description
1	10	Console Bracket Screw	65	4	3/8" Flat Washer
2	2	Crossbar Bolt	66	2	Resistance Bracket
3	2	Crossbar Washer	67	2	Resistance Bolt
4	1	Left Console Bracket	68	2	Upright Cable Loom
5	2	Foam Grip	69	2	Upright Pivot Bolt
6*	1	Console	70	4	Front Wheel Bolt/Pivot Bolt
7	8	Console Screw	71	4	Wheel Spacer
8	2	Ground Wire Grommet	72	4	Washer
9	4	Crossbar Screw	73	8	Base Pad
10	8	Cage Nut	74	4	Wheel
11	2	Upright	75	1	Base
12	2	Upper Body Arm w/Foam	76	2	Upright Pivot Washer
13	1	Key/Clip	77	4	Resistance Bracket Bolt
14	1	Spring Sleeve	78	2	Foot Rail
15	1	Pot Wire Harness	79	1	Power Cord
16	1	Upright Wire Harness	80	1	Grommet
17	1	Console Crossbar	81	30	Safety Cover Screw/Hood Screw
18	2	Crossbar Bracket	82	1	Safety Cover
19*	1	Motor/Pulley/Flywheel/Fan	83	2	Base Shock Nut
20	1	Motor	84	1	Base Shock Bolt
21	1	Pulley/Flywheel/Fan	85	1	Base Shock
22	1	Water Bottle Holder Insert	86	8	Isolator
23	1	Potentiometer	87	2	Belt Guide
24	1	Speed Knob	88	1	Stabilizer Plate
25	1	Motor Belt	89	4	Roller Guard
26	7	Nut	90	1	Front Roller/Pulley
27	9	Motor Tension Bolt/Upright Bolt	91	1	Walking Platform
28	1	Motor Tension Washer	92	1	Walking Belt
29	5	Star Washer	93	8	Platform Screw
30	2	Motor Bolt	94	1	Left Rear Roller Adj. Bolt
31	1	Wire Tie	95	3	Wheel Nut/Stabilizer Plate Nut
32	1	Front Hood	96	1	Tension Spring
33	8	Hood Anchor Screw	97	1	Short Reed Switch
34	1	Motor Tension Nut	98	4	Resistance Bracket Washer
35	1	Motor Mount Bracket	99	1	Battery Cover
36	4	Rubber Hood Anchor	100	2	Incline Leg Bracket
37	4	Metal Hood Anchor	101	2	Guard Spring
38	1	Front Hood Spacer	102	1	Roller Tension Nut
39	1	Motor Swivel Bolt	103	1	Rear Roller Guard
40	2	Motor Nut	104	1	Rear Roller
41	1	Reed Switch Extension Wire	105	1	Stabilizer Plate Bolt
42	1	Reed Switch/Sensor Wire	106	4	Ratchet Mounting Screw
43	1	Magnet	107	2	Incline Leg Spring
44	2	Adhesive Clip	108	4	Incline Leg Spacer
45	14	Screw	109	2	Incline Leg Latch
46	3	Wire Clip	110	8	Isolator Cover
47	1	Square Plug	111	1	Upright Plug
48	1	Electronics Bracket	112	2	Incline Wheel Bolt
49	1	Controller	113	1	Right Rear Roller Adj. Bolt
50	1	Choke	114	2	Incline Leg
51	1	Right Console Bracket	115	1	Rear Hood Spacer
52	1	Wire Guard	116	2	8" Wire Tie
53	1	Circuit Breaker	117	2	Upright Pivot Nut
54	1	Front Roller Adjustment Bolt	118	1	Tie Holder Clamp
55	5	Adjustment Washer	119	1	Rear Hood
56	1	Frame	120	1	100" Green Ground Wire
57	1	Allen Wrench	121	1	Ground Wire Screw
58	2	5/8" Flat Washer	#	1	4" Black Wire, Male/Female
59	2	Resistance Knob	#	1	8" White Wire, Male/Female
60	2	Resistance Cone	#	1	User's Manual
61	2	Resistance Sleeve			
62	2	Spring Washer			
63	4	Thrust Washer			
64	2	Thrust Bearing			

\* Includes all parts shown in the box

# These parts are not illustrated



# ORDERING REPLACEMENT PARTS

To order replacement parts, call our Customer Service Department toll-free at 1-800-999-3756, Monday through Friday, 6 a.m. until 6 p.m. Mountain Time (excluding holidays). When ordering parts, please be prepared to give the following information:

- The MODEL NUMBER OF THE PRODUCT (PFTL20462).
- The NAME OF THE PRODUCT (PROFORM® CROSSWALK si treadmill).
- The SERIAL NUMBER OF THE PRODUCT (see the front cover of this manual).
- The KEY NUMBER OF THE PART(S) (see the EXPLODED DRAWING and PART LIST attached to the center of this manual).
- The DESCRIPTION OF THE PART(S) (see the EXPLODED DRAWING and PART LIST attached to the center of this manual).

If possible, place the treadmill near your telephone for easy reference when calling.

## LIMITED WARRANTY

ICON Health & Fitness, Inc. ("ICON"), warrants this product to be free from defects in workmanship and material, under normal use and service conditions, for a period of ninety (90) days from the date of purchase. This warranty extends only to the original purchaser. ICON's obligation under this warranty is limited to replacing or repairing, at ICON's option, the product at one of its authorized service centers. All products for which warranty claim is made must be received by ICON at one of its authorized service centers with all freight and other transportation charges prepaid, accompanied by sufficient proof of purchase. All returns must be pre-authorized by ICON. This warranty does not extend to any product or damage to a product caused by or attributable to freight damage, abuse, misuse, improper or abnormal usage or repairs not provided by an ICON authorized service center, to products used for commercial or rental purposes, or to products used as store display models. No other warranty beyond that specifically set forth above is authorized by ICON.

ICON IS NOT RESPONSIBLE OR LIABLE FOR INDIRECT, SPECIAL OR CONSEQUENTIAL DAMAGES ARISING OUT OF OR IN CONNECTION WITH THE USE OR PERFORMANCE OF THE PRODUCT OR OTHER DAMAGES WITH RESPECT TO ANY ECONOMIC LOSS, LOSS OF PROPERTY, LOSS OF REVENUES OR PROFITS, LOSS OF ENJOYMENT OR USE, COSTS OF REMOVAL, INSTALLATION OR OTHER CONSEQUENTIAL DAMAGES OF WHATSOEVER NATURE. SOME STATES DO NOT ALLOW THE EXCLUSION OR LIMITATION OF INCIDENTAL OR CONSEQUENTIAL DAMAGES. ACCORDINGLY, THE ABOVE LIMITATION MAY NOT APPLY TO YOU.

THE WARRANTY EXTENDED HEREUNDER IS IN LIEU OF ANY AND ALL OTHER WARRANTIES AND ANY IMPLIED WARRANTIES OF MERCHANTABILITY OR FITNESS FOR A PARTICULAR PURPOSE IS LIMITED IN ITS SCOPE AND DURATION TO THE TERMS SET FORTH HEREIN. SOME STATES DO NOT ALLOW LIMITATIONS ON HOW LONG AN IMPLIED WARRANTY LASTS. ACCORDINGLY, THE ABOVE LIMITATION MAY NOT APPLY TO YOU.

This warranty gives you specific legal rights. You may also have other rights which vary from state to state.

**ICON HEALTH & FITNESS, INC., 1500 S. 1000 W., LOGAN, UT 84321-9813**