

# PRO-FORM® 785xt

Model No. PFTL20860

Serial No. \_\_\_\_\_

Serial  
Number  
Decal

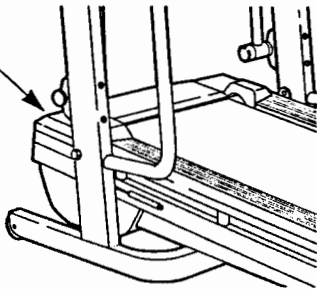

RELEASED TO  
FEB 15  
MANUFACTURING

## QUESTIONS?

As a manufacturer, we are committed to providing complete customer satisfaction. If you have questions, or find that there are missing or damaged parts, we will guarantee you complete satisfaction through direct assistance from our factory.

TO AVOID UNNECESSARY DELAYS, PLEASE CALL DIRECT TO OUR TOLL-FREE CUSTOMER HOT LINE. The trained technicians on our Customer Hot Line will provide immediate assistance, free of charge to you.

CUSTOMER HOT LINE:  
**1-800-999-3756**  
Mon.-Fri., 6 a.m.-6 p.m. MST

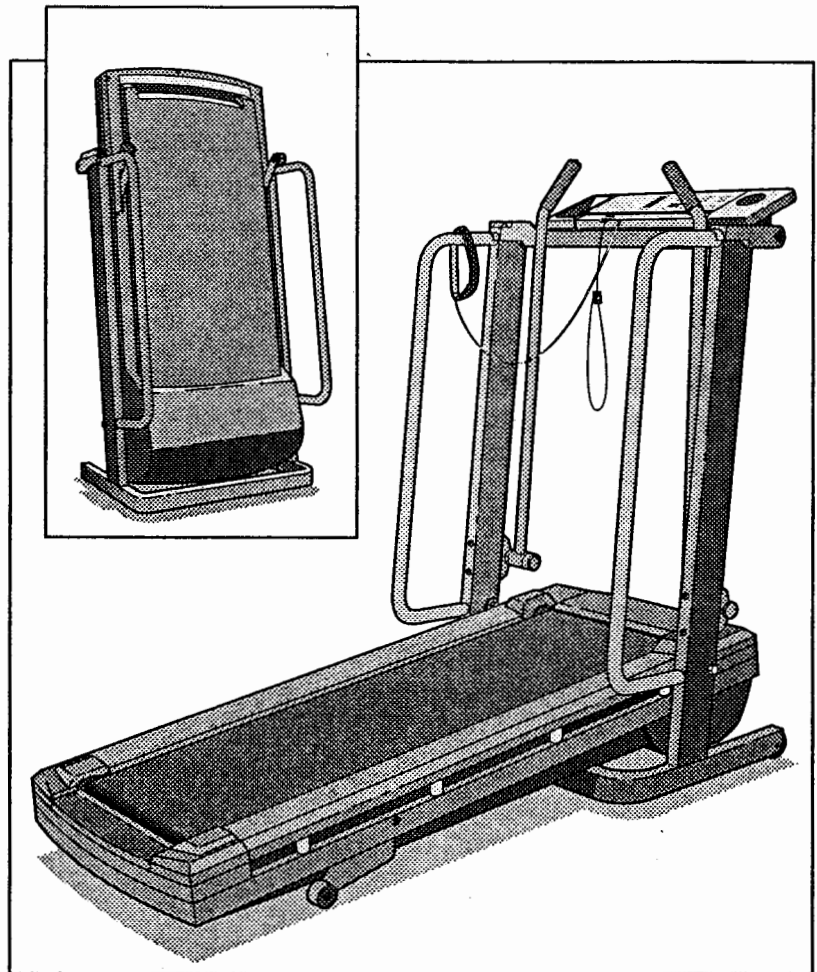

## ⚠ CAUTION

Read all precautions and instructions in this manual before using this equipment. Save this manual for future reference.

## USER'S MANUAL

# PRO-FORM<sup>®</sup> 785xt

## TABLE OF CONTENTS

IMPORTANT PRECAUTIONS .....	3
BEFORE YOU BEGIN .....	4
ASSEMBLY .....	5
HOW TO USE THE PULSE SENSOR .....	8
OPERATION AND ADJUSTMENT .....	9
HOW TO USE THE MANUAL MODE .....	11
HOW TO USE PROGRAMS A, B, C, AND D .....	13
HOW TO USE THE FAT BURN AND AEROBIC PROGRAMS .....	15
HOW TO USE THE FITNESS TEST PROGRAM .....	16
HOW TO FOLD AND MOVE THE TREADMILL .....	18
TROUBLE-SHOOTING .....	20
CONDITIONING GUIDELINES .....	22
ORDERING REPLACEMENT PARTS .....	Back Cover
LIMITED WARRANTY .....	Back Cover

Note: An EXPLODED DRAWING and a PART LIST are attached to the center of this manual. Save the EXPLODED DRAWING and PART LIST for future reference.



**▲WARNING:** Before beginning this or any exercise program, consult your physician. This is especially important for persons over the age of 35 or persons with pre-existing health problems. Read all instructions before using. ICON assumes no responsibility for personal injury or property damage sustained by or through the use of this product.

# IMPORTANT PRECAUTIONS

**⚠ WARNING:** To reduce the risk of burns, fire, electric shock or injury to persons, read the following important precautions and information before operating the treadmill.

1. It is the responsibility of the owner to ensure that all users of this treadmill are adequately informed of all warnings and precautions.
2. Use the treadmill only as described in this manual.
3. Place the treadmill on a level surface, with eight feet of clearance behind it. Do not place the treadmill on any surface that blocks air openings. To protect the floor or carpet from damage, place a mat under the treadmill.
4. Keep the treadmill indoors, away from moisture and dust. Do not put the treadmill in a garage or covered patio, or near water.
5. Do not operate the treadmill where aerosol products are used or where oxygen is being administered.
6. Keep small children and pets away from the treadmill at all times.
7. The treadmill should be used only by persons weighing 250 pounds or less. Do not allow more than one person on the treadmill at a time.
8. When connecting the power cord (see HOW TO PLUG IN THE POWER CORD on page 9), plug the power cord into a surge protector (not included) and plug the surge protector into a grounded circuit capable of carrying 15 or more amps. No other appliance should be on the same circuit.
9. Use only a UL-listed surge protector, rated at 15 amps, with a 14-gauge cord of five feet or less in length. Do not use an extension cord.
10. Keep the power cord and the surge protector away from heated surfaces.
11. Never move the walking belt while the power is turned off. Do not operate the treadmill if the power cord or plug is damaged, or if the treadmill is not working properly. (See BEFORE YOU BEGIN on page 4 if the treadmill is not working properly.)
12. Wear appropriate clothing when using the treadmill; do not wear loose clothing that could become caught in the treadmill. Athletic support clothes are recommended for both men and women. *Always wear athletic shoes; never use the treadmill with bare feet, wearing only stockings or in sandals.*
13. Never start the treadmill while you are standing on the walking belt. Always hold the handrails or upper body arms while using the treadmill.
14. The treadmill is capable of high speeds. Adjust the speed in small increments to avoid sudden jumps in speed.
15. To reduce the possibility of the treadmill overheating, do not operate the treadmill continuously for longer than 1 hour.
16. The pulse sensor is not a medical device. Various factors, including the user's movement, may affect the accuracy of heart rate readings. The pulse sensor is intended only as an exercise aid in determining heart rate trends in general.
17. Never leave the treadmill unattended while it is running. Always remove the key and move the on/off switch to the "off" position when the treadmill is not in use. (See the drawing on page 4 for the location of the on/off switch.)
18. You must be able to safely lift 45 pounds (20 kg) to raise, lower, or move the treadmill.
19. When storing the treadmill, make sure that the storage latch is fully closed.
20. Never insert any object into any opening.
21. Inspect and tighten all parts on the treadmill every three months.
22. Always unplug the power cord before performing the maintenance and adjustment procedures described in this manual. Never remove the motor hood unless instructed to do so by an authorized service representative. Servicing other than the procedures in this manual should be performed by an authorized service representative only.

**SAVE THESE INSTRUCTIONS**

# BEFORE YOU BEGIN

Thank you for selecting the PROFORM® 785xt treadmill. The 785xt treadmill combines advanced technology with innovative design to offer you an excellent form of cardiovascular exercise, in the convenience and privacy of your home. And when you're not exercising, the unique 785xt can be folded up, requiring less than half the floor space of other treadmills.



at 1-800-999-3756, Monday through Friday, 6 a.m. until 6 p.m. Mountain Time (excluding holidays). To help us assist you, please note the product model number and serial number before calling. The model number of the treadmill is PFTL20860. The serial number can be found on a decal attached to the treadmill (see the front cover of this manual for the location).

**For your benefit, read this manual carefully before using the treadmill.** If you have additional questions, please call our Customer Service Department toll-free

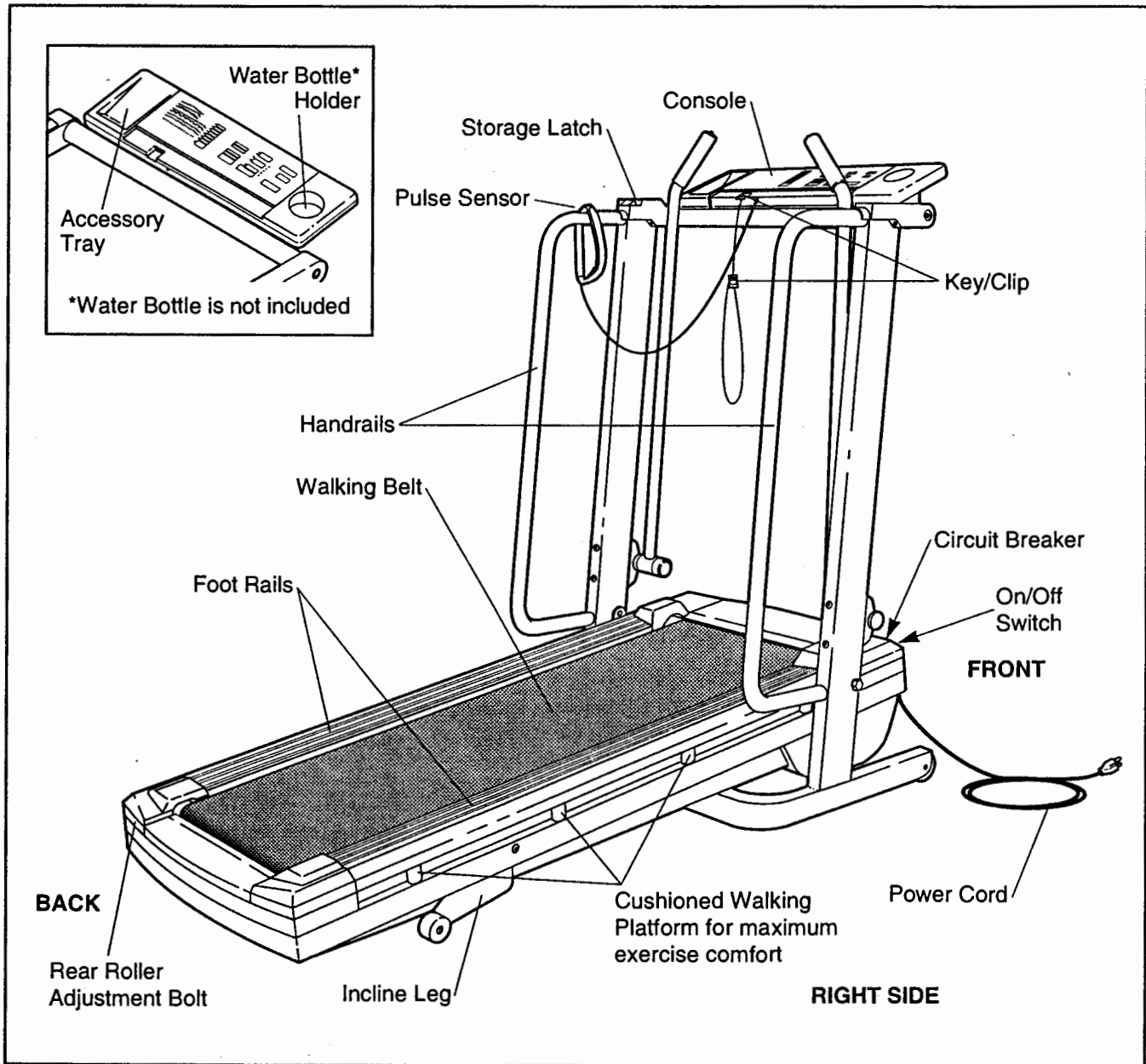
Before reading further, please review the drawing below and familiarize yourself with the labeled parts.

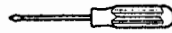

# ASSEMBLY

**Assembly requires two people.** Set the treadmill in a cleared area and remove all packing materials. Do not dispose of the packing materials until assembly is completed. **Tools required for assembly:** The included 7/32" allen wrench  and your phillips screwdriver  and (2) adjustable wrenches .

1. Firmly hold the Uprights (11, 58) as shown. Raise the Uprights until the base is resting on the floor.

The inset drawing shows how the treadmill should appear when this step is completed.

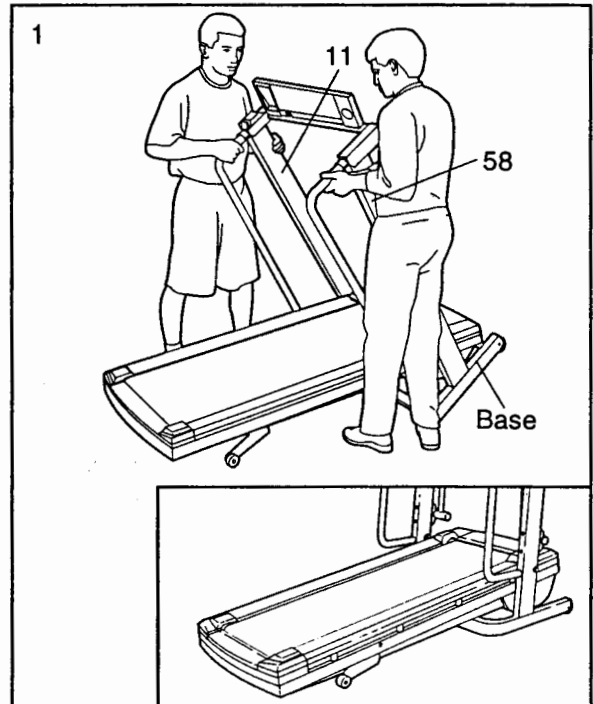

2. Loosen the Crossbar Bolts (2) in the ends of the Console Crossbar (17). Pivot the Console (6) to the angle shown. Look under the Left and Right Crossbar Brackets (4, 51) and find the two small holes in each end of the Console Crossbar (17). Tighten Crossbar Screws (9) into all four holes.

Pivot the Console (6) upward until it stops. Using the 7/32" Allen Wrench (56), tighten the Crossbar Bolts (2).

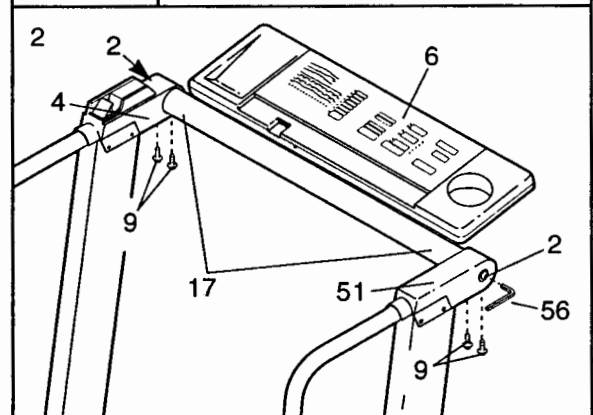

3. Next, the treadmill should be raised to the storage position. Hold the treadmill with your hands in the locations shown at the right. **To decrease the possibility of injury, bend your legs and keep your back straight. As you raise the treadmill, make sure to lift with your legs rather than your back.** Raise the treadmill about halfway to the vertical position.

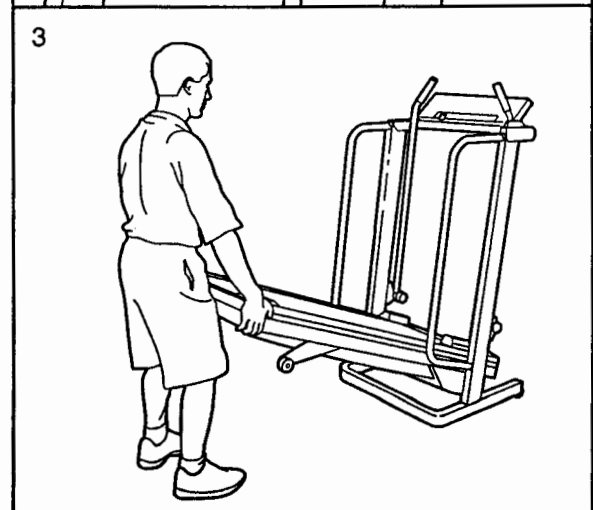

RELEASED TO  
FEB 15  
MANUFACTURING

4. Move your right hand to the position shown at the right, and hold the treadmill firmly. Using your left hand, lift the storage latch. Raise the treadmill until the locking pin snaps into the storage latch. **Make sure that the locking pin is inside the storage latch, and that the storage latch is fully closed.**

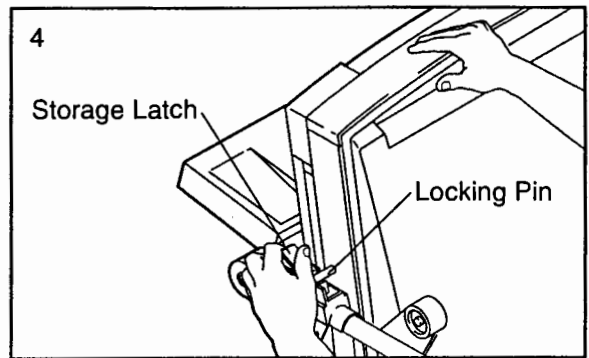

5. Stand behind the treadmill. Hold the Right Crossbar Bracket (51) and the Left Crossbar Bracket (not shown). Place one foot on the base in the indicated location.

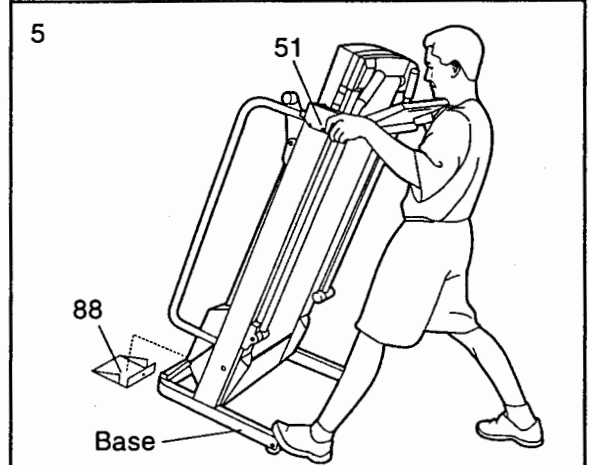

Tip the treadmill back slightly. While the treadmill is held in this position, a second person should slide the Stabilizer Plate (88) onto the base (see the inset drawing).

Keeping your foot on the base, carefully tip the treadmill up until it is resting on the base. Make sure that the Stabilizer Plate (88) stays on the base.

Attach the Stabilizer Plate (88) to the base with a Stabilizer Plate Bolt (105), two Stabilizer Plate Washers (97), and the Stabilizer Plate Nut (95) as shown.

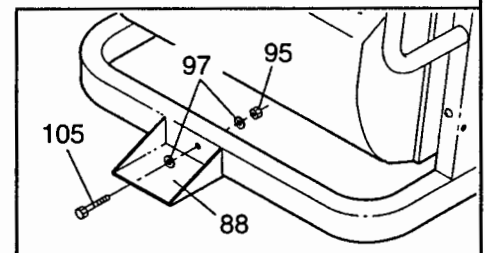

6. See assembly step 4. Hold the upper end of the treadmill with your right hand as shown. Using your left hand, lift the storage latch. Pivot the treadmill slightly until the locking pin is out of the storage latch.

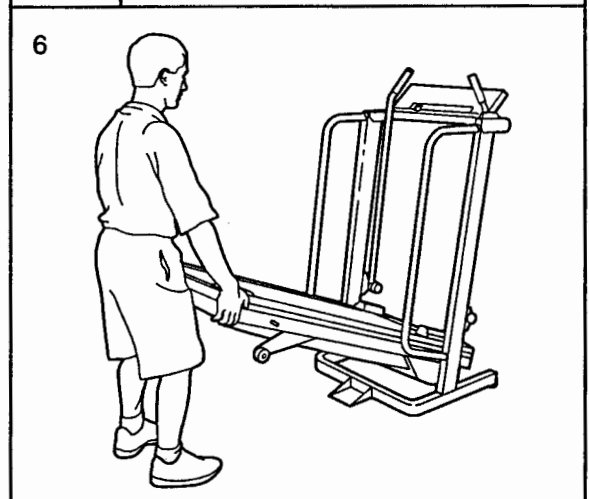

Hold the treadmill firmly with both hands, and lower the treadmill to the floor. **To decrease the possibility of injury, bend your legs and keep your back straight.**

7. Remove the paper backing from the Adhesive Clip (44). Press the Adhesive Clip onto the Frame (84) in the indicated location. Press the 3/16" Allen Wrench (57) into the Adhesive Clip. The use of the 3/16" Allen Wrench is described on page 21.

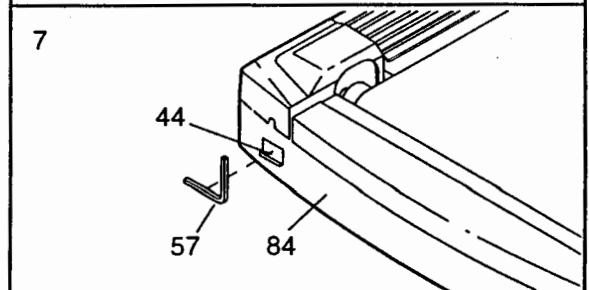

8. Attach the Pulse Sensor (23) to one of the Headbands (125 or 126). Make sure that the sensor window is pressed through the indicated hole in the Headband.

Press open the clothes clip, and insert the pulse sensor wire into the clothes clip. **Make sure that the pulse sensor wire is resting against the hinge of the clothes clip (see the inset drawing).** The use of the pulse sensor is explained on page 8.

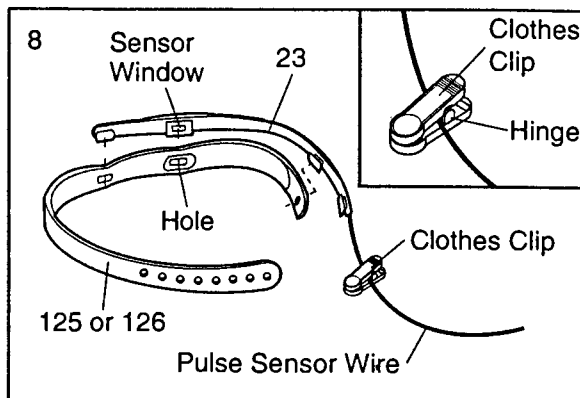

Make sure that all parts are tightened before you use the treadmill. **Note: To protect the floor or carpet from damage, place a mat under the treadmill.**

RELEASED TO  
FEB 15  
MANUFACTURING

# HOW TO USE THE PULSE SENSOR

The unique headband-style pulse sensor is specially designed for greater accuracy, comfort, and durability. **To get the best performance from the pulse sensor, please read the following instructions.**

## HOW TO ADJUST THE HEADBAND

For the pulse sensor to function properly, the headband should fit snugly around your head, without being uncomfortable.

To adjust the headband, insert the adjustment tab through one of the holes in the headband. **Note: Each time you exercise, the headband may expand slightly during the first few minutes of use. It may be necessary to readjust the headband periodically.**

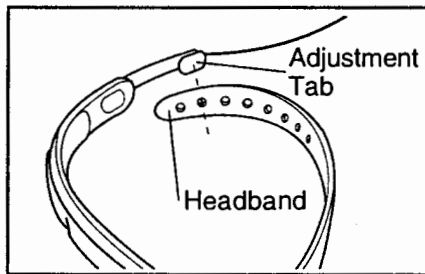

## HOW TO PUT ON THE PULSE SENSOR

Rub your forehead briefly to stimulate circulation. Put on the headband as shown below, with the sensor window centered on your forehead. Make sure that there is no hair between the sensor window and your forehead. Attach the clothes clip to your collar. The clothes clip will reduce the movement of the pulse sensor wire, helping to ensure accurate pulse readings.

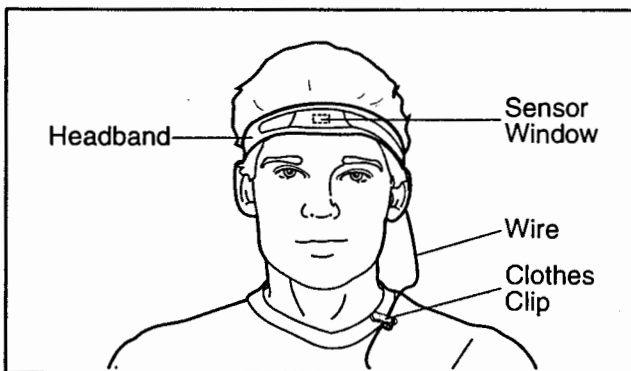

**IMPORTANT: To avoid static build-up that may damage the console, wear the pulse sensor only while you are on the treadmill.**

## GUIDELINES FOR ACCURATE PULSE READINGS

The instructions on page 12 explain how the pulse sensor is used with the console (see PULSE

DISPLAY). For the best results, remember the following important guidelines:

1. Before putting on the headband, rub your forehead briefly to stimulate circulation.
2. Make sure that the headband fits snugly, without being uncomfortable. If the headband is too loose or tight, your pulse may not be detected.
3. The headband must be worn with the sensor window centered on your forehead. Make sure that there is no hair between the sensor window and your forehead. Make-up applied to the forehead may interfere with pulse readings. **Note:** If the pulse sensor does not detect your pulse when the sensor window is centered on your forehead, try positioning the sensor window above your right or left eyebrow. Depending on the shape of your forehead, it may be easier to detect your pulse from a different position.
4. Make sure that the pulse sensor wire is fully plugged into the jack on the console.
5. Because your pulse constantly changes, the pulse sensor will sample your pulse every few seconds. When you first put on the pulse sensor, it may take up to ten seconds for an accurate pulse to be shown.
6. Avoid excessive head movement during exercise.
7. The sensor window should be cleaned weekly when the treadmill is used regularly. Moisten a cotton swab with water, and carefully wipe the sensor window.

## HOW TO SOLVE COMMON PULSE PROBLEMS

1. If you are wearing the pulse sensor and the NO PULSE DETECTED indicator lights, refer to guidelines 2, 3, 4, 5, 6, and 7 above.
2. If the pulse shown in the PULSE display seems excessively high or low, refer to guideline 5.
3. If error code "E5" appears in the PULSE display, refer to guidelines 2, 3, 4, 5, 6, and 7.
4. If the letters "PLS" appear in the PULSE display, refer to guidelines 2, 3, 4, 5, 6, and 7.

## CLEANING THE PULSE SENSOR AND HEADBAND

Remove the headband from the pulse sensor. Wipe the pulse sensor with a damp cloth; **never immerse the pulse sensor in water.** Hand wash the headband in mild detergent, gently wring it out, and let it air dry.

# OPERATION AND ADJUSTMENT

## THE PERFORMANT LUBE™ WALKING BELT

Your treadmill features a walking belt coated with PERFORMANT LUBE™, a high-performance lubricant. **IMPORTANT:** Never apply silicone spray or other substances to the walking belt or the walking platform. They will deteriorate the walking belt and cause excessive wear.

## HOW TO PLUG IN THE POWER CORD

Your treadmill, like any other type of sophisticated

**⚠ DANGER:** Improper connection of the equipment-grounding conductor can result in an increased risk of electric shock. Check with a qualified electrician or serviceman if you are in doubt as to whether the product is properly grounded. Do not modify the plug provided with the product—if it will not fit the outlet, have a proper outlet installed by a qualified electrician.

electronic equipment, can be seriously damaged by sudden voltage changes in your home's power. Voltage surges, spikes, and noise interference can result from weather conditions or from other appliances being turned on or off.

**To decrease the possibility of your treadmill being damaged, always use a surge protector (not included) with your treadmill.**

Surge protectors are sold at most hardware stores and department stores. Use only a UL-listed surge protector, rated at 15 amps, with a 14-gauge cord of five feet or less in length.

**This product must be grounded.** If it should malfunction or break down, grounding provides a path of least resistance for electric current to reduce the risk of

electric shock. This product is equipped with a cord having an equipment-grounding conductor and a grounding plug. **Plug the power cord into a surge protector, and plug the surge protector into an appropriate outlet that is properly installed and grounded in accordance with all local codes and ordinances.**

This product is for use on a nominal 120-volt circuit, and has a grounding plug that looks like the plug illustrated in drawing 1 below. A temporary adapter that looks like the adapter illustrated in drawing 2 may be used to connect the surge protector to a 2-pole receptacle as shown in drawing 2 if a properly grounded outlet is not available.

The temporary adapter should be used only until a properly grounded outlet (drawing 1) can be installed by a qualified electrician.

The green-colored rigid ear, lug, or the like extending from the adapter must be connected to a permanent ground such as a properly grounded outlet box cover. Whenever the adapter is used it must be held in place by a metal screw. **Some 2-pole receptacle outlet box covers are not grounded. Contact a qualified electrician to determine if the outlet box cover is grounded before using an adapter.**

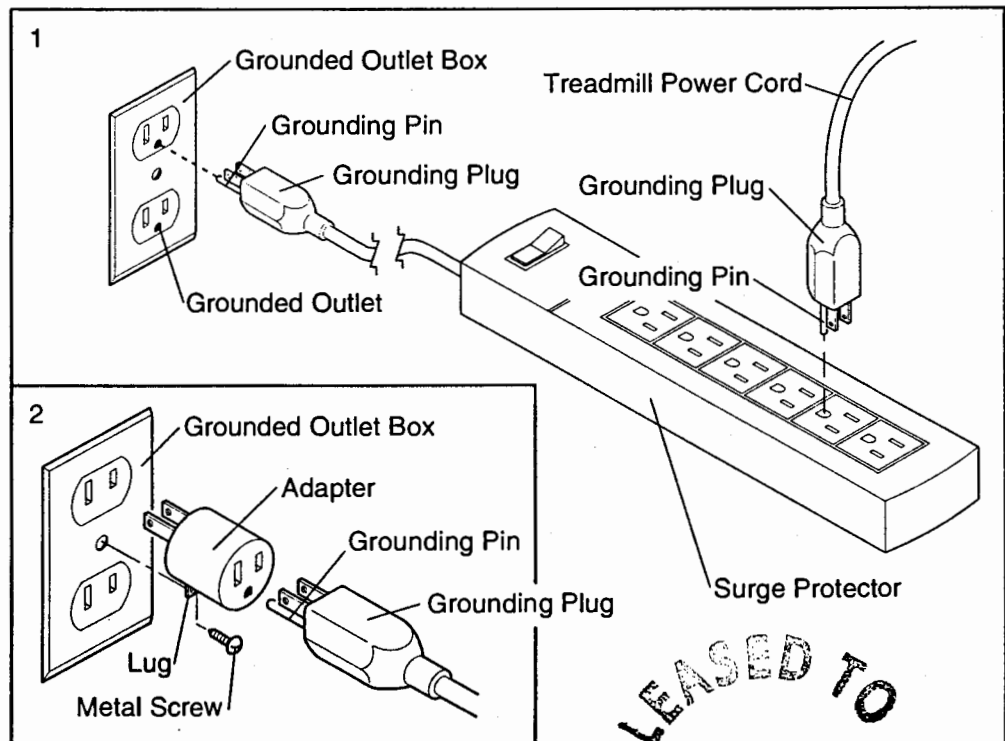

RELEASED TO  
FEB 15  
PING

## DIAGRAM OF THE CONSOLE

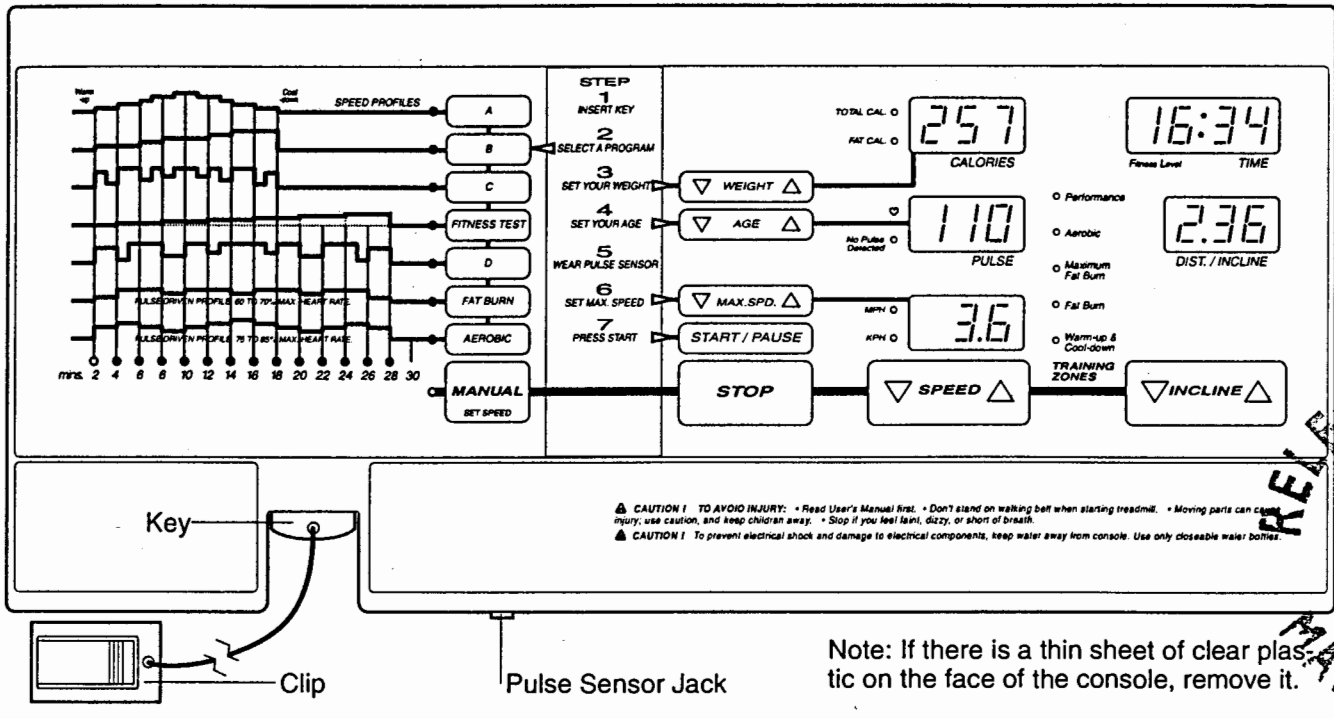

RELEASED  
FEB 15  
MANUFACTURE

### CAUTION: Before operating the console, read the following precautions.

- Do not stand on the walking belt when turning on the power or starting the walking belt.
- Always wear the clip (see the drawing above) while operating the treadmill. If the key is pulled from the console, the walking belt will stop.
- The treadmill is capable of high speeds. Adjust the speed in small increments.
- The pulse sensor is not a medical device. Various factors, including the user's movement, may affect the accuracy of pulse readings. The pulse sensor is intended only as an exercise aid in determining pulse trends in general.
- If you have heart problems, or if you are over 60 years of age and have been inactive, do not use the FAT BURN program or the AEROBIC program. If you are taking medication regularly, consult your physician to find whether the medication will affect your exercise heart rate.
- To reduce the risk of electric shock, keep the console dry, avoid spilling liquids on the console, and use only a sealed water bottle.

### FEATURES OF THE CONSOLE

The treadmill console offers an impressive array of features designed to make your workouts more effective and enjoyable. When the console is in the manual mode, the speed and incline of the treadmill can be changed with a touch of a button. As you exercise, five displays will provide continuous exercise feedback. Seven preset programs are also offered. Programs A, B, C, and D automatically control the speed of the treadmill as they guide you through effective workouts; the special FAT BURN program provides intensive fat-burning workouts; the AEROBIC program helps you to achieve maximum cardiovascular benefits; and the unique FITNESS TEST program measures your relative fitness level.

To use the manual mode, follow the steps on pages 11 through 13. To use program A, B, C or D, see pages 13 and 14. To use the FAT BURN or AEROBIC program, see pages 15 and 16. To use the FITNESS TEST program, see pages 16 and 17. Note: The console can display speed and distance in either miles or kilometers (see SPEED DISPLAY on page 12). For simplicity, all instructions refer to miles.

Before beginning, make sure that the on/off switch located near the power cord is in the "on" position. Plug in the power cord (see page 9). Note: If the key is in the console when the power cord is plugged in, the letters "PO" will flash in the SPEED display. If this occurs, remove the key.

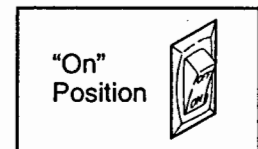

## HOW TO USE THE MANUAL MODE

### 1 Insert the key fully into the console.

Stand on the foot rails and insert the key. Various displays and indicators will light. Find the clip attached to the key, and slide it onto the waistband of your clothing.

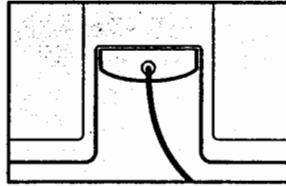

### 2 Select the MANUAL mode.

When the key is inserted, the manual mode will automatically be selected. The indicator beside the MANUAL button will light. Note: If a preset program has been selected, press the MANUAL button to select the manual mode.

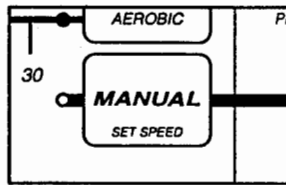

### 3 Enter your weight, if desired.

Although it is not necessary to enter your weight and age to use the manual mode, the CALORIES display will be more accurate if your weight and age are entered. To enter your weight:

- Press the WEIGHT increase or decrease button. The letters "LbS" will flash in the

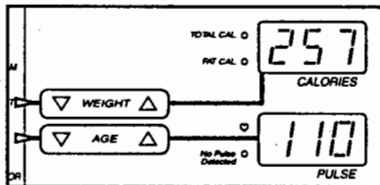

CALORIES display. Press one of the WEIGHT buttons again. The current weight setting will then be shown. Press the WEIGHT buttons again to enter your weight. Each time one of the buttons is pressed, the weight setting will change by 1 pound. If one of the buttons is held down, the weight setting will change in increments of 5 pounds. After you have entered your weight, your weight will be shown in the CALORIES display for three seconds.

### 4 Enter your age, if desired.

To enter your age:

- Press the AGE increase or decrease button. The letters "AGE" will flash in the PULSE display. Press one of the AGE buttons again. The current age setting will then be shown. Press the AGE

buttons again to enter your age. Each time one of the buttons is pressed, the age setting will change by 1 year. If one of the buttons is held down, the age setting will change in increments of 5 years. After you have entered your age, your age will be shown in the PULSE display for three seconds.

Note: Once you have entered your weight and age, the numbers will be saved in the console's memory, even if the power cord is unplugged.

### 5 Put on the pulse sensor, if desired.

For the PULSE display to show your pulse, the pulse sensor must be worn. To put on the pulse sensor, see HOW TO USE THE PULSE SENSOR on page 8. Plug the pulse sensor wire fully into the jack on the front of the console.

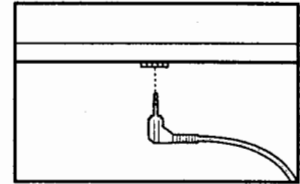

### 6 Press the SPEED increase button to start the walking belt.

The speed of the walking belt is controlled with the SPEED increase and decrease buttons. Each time one of the buttons is pressed, the speed will change by 0.1 mile per hour (mph). The buttons can be held down to change the speed more quickly. The speed range is 0.5 mph to 10 mph.

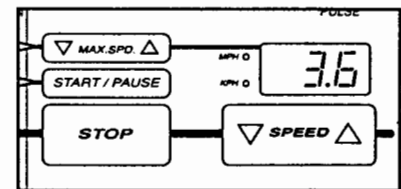

Press the SPEED increase button until the walking belt begins to move at slow speed. Hold the handrails and carefully begin walking. Change the speed of the walking belt as desired by pressing the SPEED buttons. Note: The walking belt can also be started by pressing the START/PAUSE button. The walking belt will begin to move at 0.5 mph. The speed can then be adjusted with the SPEED buttons.

Press the SPEED increase button until the walking belt begins to move at slow speed. Hold the handrails and carefully begin walking. Change the speed of the walking belt as desired by pressing the SPEED buttons. Note: The walking belt can also be started by pressing the START/PAUSE button. The walking belt will begin to move at 0.5 mph. The speed can then be adjusted with the SPEED buttons.

To stop the walking belt, press the START/PAUSE button. All displays will pause and the TIME display will begin to flash. To restart the walking belt, press the SPEED buttons or the START/PAUSE button as described above. Note: The walking belt can also be stopped by pressing the STOP button. To restart the walking belt, press the SPEED buttons or the START/PAUSE button as described above.

Note: When the SPEED buttons are pressed, the SPEED display will show the selected speed setting for seven seconds. The display will then show the actual speed of the walking belt.

## 7 Change the incline of the treadmill, if desired.

The incline of the treadmill is controlled with the INCLINE increase and decrease buttons. Each time one of the buttons is pressed, the incline will change by 0.5%.

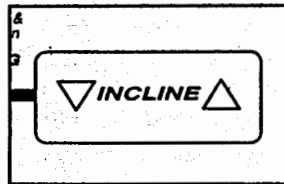

The buttons can be held down to change the incline more quickly. The incline setting is shown in the DISTANCE/INCLINE display. The incline range is 1.5% to 10%. Note: After the INCLINE buttons are pressed, it may take a few seconds for the treadmill to reach the selected incline setting.

## 8 Follow your progress with the five displays and the TRAINING ZONE monitor.

### • CALORIES display

This display shows both the *total calories* and the number of *fat calories* that you have burned. (See BURNING FAT on page 22).

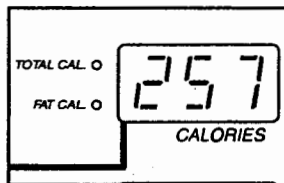

Every seven seconds, the display will change from one number to the other. The indicators beside the display will light to show which number is currently shown.

Note: This display also shows the current weight setting when the walking belt is stopped and the WEIGHT buttons are pressed.

### • PULSE display

For this display to operate, the pulse sensor must be worn (see HOW TO USE THE PULSE SENSOR on page 8). The pulse sensor wire must be plugged fully into the jack on the front of the console. After a few seconds, the heart-shaped indicator beside the PULSE display will flash each time your heart beats, the NO PULSE DETECTED indicator will darken, and your pulse will be shown. Note: Because your pulse constantly changes, the pulse sensor will sample your pulse every few seconds. *It may take up to ten seconds before an accurate pulse is shown.* If your pulse is not shown, see GUIDELINES FOR ACCURATE PULSE READINGS on page 8.

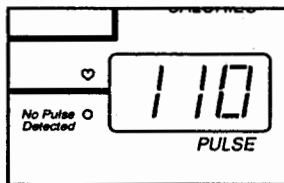

Note: This display also shows the current age setting when the walking belt is stopped and the AGE buttons are pressed.

### • SPEED display

This display shows the current speed of the walking belt. When the SPEED buttons are pressed, the display will show the selected speed setting for seven seconds.

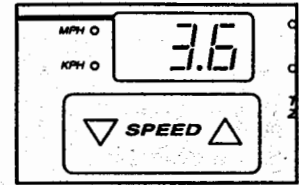

Note: The speed can be displayed in either miles per hour (mph) or kilometers per hour (kph). The indicators beside the SPEED display will light to show which unit of measurement is selected. To change the unit of measurement, hold down the STOP button while inserting the key into the console. An "E" (for English system—miles) or "M" (for Metric system—kilometers) will appear in the SPEED display. Press the SPEED increase button to change the unit of measurement. Remove and then reinsert the key.

### • TIME display

This display shows the total time that the walking belt has been moving.

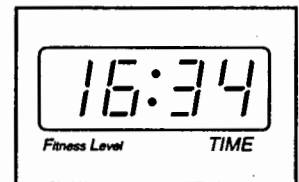

Note: When any program except the FITNESS TEST program is selected, the TIME display will show the time remaining in the program.

### • DISTANCE/INCLINE display

This display shows both the distance that the walking belt has moved and the current incline of the treadmill. Every seven seconds, the display will change from one number to the other. When the INCLINE buttons are pressed, the display will change to show the selected incline setting.

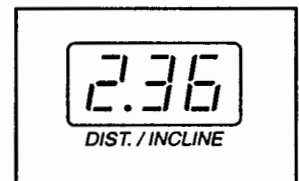

Note: If the MPH indicator beside the SPEED display is lit, the distance will be displayed in miles. If the KPH indicator is lit, the distance will be displayed in kilometers.

### • Training Zone Monitor

This monitor measures the approximate intensity of your exercise. The monitor's five indicators are described below:

• WARM UP & COOL DOWN—Each workout should begin with a warm-

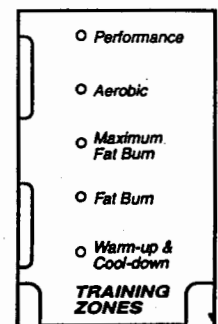

up period and end with a cool-down period. (See **WORKOUT GUIDELINES** on pages 22 and 23.) The **WARM-UP & COOL-DOWN** indicator will light when your workout intensity is ideal for warming up or cooling down.

- **FAT BURN** and **MAXIMUM FAT BURN**—To burn fat effectively, you must exercise at a relatively low intensity level for a sustained period of time. (See **BURNING FAT** on page 22.) If you are exercising at the proper intensity level for burning fat, the **FAT BURN** or **MAXIMUM FAT BURN** indicator will light.
- **AEROBIC**—If your goal is to strengthen your cardiovascular system, your exercise must be “aerobic.” (See **AEROBIC EXERCISE** on page 22.) If you are exercising at the proper intensity level for aerobic exercise, the **AEROBIC** indicator will light.
- **PERFORMANCE**—If your goal is high performance athletic conditioning, you will need to exercise at a high intensity level. If you are exercising at the proper intensity level, the **PERFORMANCE** indicator will light.

**9** When you are finished exercising, stop the walking belt and remove the key.

Step onto the foot rails, stop the walking belt, and remove the key from the console. Store the key in a secure place. In addition, move the on/off switch to the “off” position. (See the drawing near the bottom of page 10.)

RELEASED TO  
FEB 15  
MANUFACTURING

**HOW TO USE PROGRAMS A, B, C, AND D**

Programs A, B, C, and D automatically control the speed of the walking belt as they guide you through effective workouts. Programs A, B, and C are 20-minute programs; program D is a 30-minute program. The speed profiles on the left side of the console show how the speed will change during each program. During program A, for example, the speed will gradually increase during the first 10 minutes, and then gradually decrease during the last 10 minutes. Each program begins with a 2-minute warm-up period, and ends with a 2-minute cool-down period.

To use program A, B, C, or D, follow the steps below.

**1** Make sure that the key is fully inserted into the console.

Stand on the foot rails and insert the key. Various displays and indicators will light. Find the clip attached to the key, and slide it onto the waistband of your clothing.

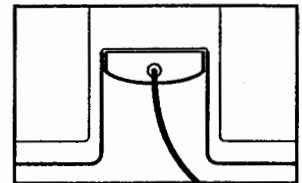

**2** Select program A, B, C, or D.

Press the program button labeled A, B, C, or D. An indicator will light next to the button you press. Note: If the walking belt is moving, it will slow to a stop.

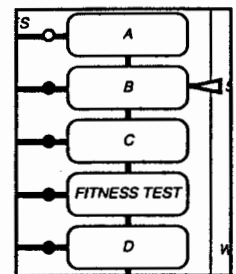

**3** Enter your weight, if desired.

When program A, B, C, or D is selected, the letters “LbS” will flash in the **CALORIES** display for seven seconds, and the current weight setting will then be shown. Although it is not necessary to enter your weight and age to use one of these programs, the **CALORIES** display will be more accurate if your weight and age are entered. If you want to enter your weight, see step 3 on page 11.

**4** Enter your age, if desired.

After you have completed step 3, the letters “AGE” will flash in the **PULSE** display for seven seconds, and the current age setting will then be shown. If you want to enter your age, see step 4 on page 11.

**5** Put on the pulse sensor, if desired.

For the PULSE display to show your pulse, the pulse sensor must be worn. To put on the pulse sensor, see HOW TO USE THE PULSE

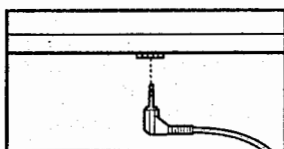

SENSOR on page 8. Plug the pulse sensor wire fully into the jack on the front of the console.

**6** Set a maximum speed for the program.

After you have completed step 4, a number will appear in the SPEED display and flash for seven seconds.

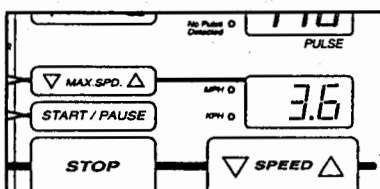

This number shows the *maximum speed* that the walking belt will move during the program. The maximum speed setting can be from 3.0 mph up to 8.5 mph. If you want to change the maximum speed setting, press the MAX. SPD. increase or decrease button. Note: The maximum speed setting will change by 0.3 mph each time one of the MAX. SPD. buttons is pressed, until it reaches 4.5 mph; the maximum speed setting will then change by 0.5 mph each time one of the buttons is pressed.

If the maximum speed setting is between 3.0 mph and 5.0 mph, the walking belt will move at 1.5 mph during the first 2 minutes and the last 2 minutes of the program (the warm-up and cool-down periods). The *speed range* during the rest of the program will be 1.5 mph. For example, if the maximum speed setting is 5.0 mph, the *speed range* will be 3.5 mph to 5.0 mph (a difference of 1.5 mph).

If the maximum speed setting is between 5.5 mph and 8.5 mph, the walking belt will move at 3.0 mph during the first 2 minutes and the last 2 minutes of the program. The *speed range* during the rest of the program will be 2.0 mph.

**7** Press the START/PAUSE button to start the program.

When the START/PAUSE button is pressed, the TIME display will begin counting down from 20 minutes (or 30 minutes if program D is selected). After a moment, the walking belt will begin to move. Hold the handrails and carefully begin walking.

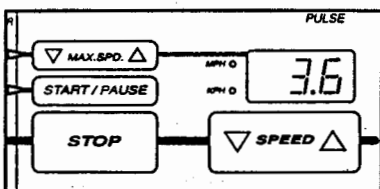

The indicators below the speed profiles will show the progress of the program.

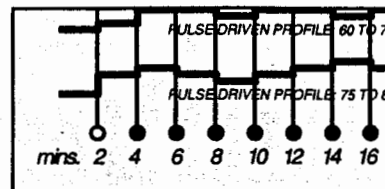

During the first 2 minutes of the program, the indicator above the number 2 will light. After 2 minutes, the indicators above the numbers 2 and 4 will light. After 4 minutes, the indicators above the numbers 4 and 6 will light, and so on. The speed of the walking belt will change periodically during the program as shown by the speed profiles. The program will continue in this manner until the time shown in the TIME display reaches zero. The walking belt will then slow to a stop and the program will be completed.

Note: The SPEED buttons will not respond while program A, B, C, or D is selected. If the program is too easy or too challenging, press the MAX. SPD. buttons to set a new maximum speed. The new maximum speed setting will be shown in the SPEED display for 3 seconds. To stop the program temporarily, press the START/PAUSE button. The TIME display will begin to flash. To restart the program, press the START/PAUSE button again. The program will resume and the walking belt will return to the latest speed setting. To terminate the program before the program is completed, press the STOP button.

**8** Change the incline of the treadmill, if desired.

When program A, B, C, or D is selected, the incline of the treadmill can be changed with the INCLINE buttons. See step 7 on page 12.

**9** Follow your progress with the five displays and the TRAINING ZONE monitor.

See TRAINING ZONE MONITOR on pages 12 and 13.

**10** When you are finished exercising, stop the walking belt and remove the key.

Step onto the foot rails, stop the walking belt, and remove the key from the console. Store the key in a secure place. In addition, move the on/off switch to the "off" position. (See the drawing near the bottom of page 10.)

RELEASED 7  
FEB 15  
MANUFAC

## HOW TO USE THE FAT BURN AND AEROBIC PROGRAMS

The FAT BURN and AEROBIC programs automatically control the speed and incline of the treadmill to keep your pulse within a predetermined range during your workouts. Both programs are 30-minute programs. The speed profiles on the left side of the console show how your pulse will change during each program. Each program begins with a warm-up period, and ends with a cool-down period.

To use one of these programs, follow the steps below.

### 1 Make sure that the key is fully inserted into the console.

Stand on the foot rails and insert the key. Various displays and indicators will light. Find the clip attached to the key, and slide it onto the waistband of your clothing.

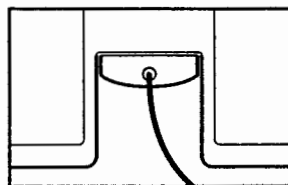

### 2 Select the FAT BURN or AEROBIC program.

Press the FAT BURN or AEROBIC button. An indicator will light next to the button you press. Note: If the walking belt is moving, it will slow to a stop.

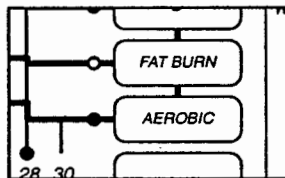

### 3 Enter your weight.

When the FAT BURN or AEROBIC program is selected, the letters "LbS" will flash in the CALORIES display. You must enter your weight and age before either of these programs can be started. To enter your weight, see step 3 on page 11. If you have already entered your weight, you must press one of the WEIGHT buttons to verify the weight setting.

### 4 Enter your age.

After you have completed step 3, the letters "AGE" will flash in the PULSE display. To enter your age, see step 4 on page 11. If you have already entered your age, you must press one of the AGE buttons to verify the age setting.

### 5 Put on the pulse sensor.

The pulse sensor must be worn when the FAT BURN or AEROBIC program is used. To put on the pulse

sensor, see HOW TO USE THE PULSE SENSOR on page 8. Plug the pulse sensor wire fully into the jack on the front of the console. Note: The FAT BURN and AEROBIC programs can be started without your pulse being detected; however, the programs will automatically stop if your pulse is not detected 2 minutes after the programs are started.

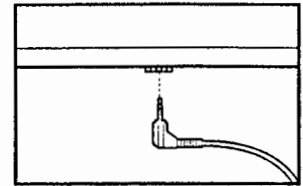

### 6 Press the START/PAUSE button to start the program.

When the START/PAUSE button is pressed, the TIME display will begin counting down from 30 minutes. After a moment, the walking belt will begin to move. Hold the handrails and carefully begin walking.

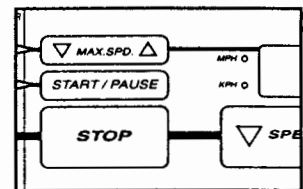

The indicators below the speed profiles will show the progress of the program.

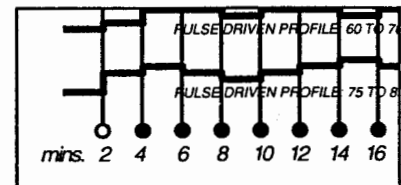

During the first 2 minutes of the program, the indicator above the number 2 will light. After 2 minutes, the indicators above the numbers 2 and 4 will light. After 4 minutes, the indicators above the numbers 4 and 6 will light, and so on. The speed and incline of the treadmill will change periodically to keep your pulse within a predetermined range, shown by the speed profiles. When the time shown in the TIME display reaches zero, the walking belt will slow to a stop and the program will be completed.

Note: If your pulse is not detected during the program, the NO PULSE DETECTED indicator will light and the letters "PLS" will flash in the PULSE

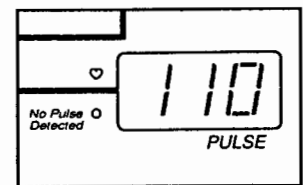

display. (See GUIDELINES FOR ACCURATE PULSE READINGS on page 8.) If your pulse is not detected at the end of any 2-minute period during the program (after 2 minutes, after 4 minutes, after 6 minutes, etc.), the program will automatically stop.

Note: Minor adjustments can be made to the speed or incline of the treadmill during the program by pressing the SPEED or INCLINE buttons. However,

if you increase the speed, the incline will automatically decrease; if you decrease the speed, the incline will automatically increase. If you increase the incline, the speed will automatically decrease; if you decrease the incline, the speed will automatically increase. The console will always attempt to keep your pulse near a predetermined setting. When the incline reaches the highest setting, the speed cannot be decreased any further. When the incline reaches the lowest setting, the speed cannot be increased any further.

Note: To terminate the program before the program is completed, press the STOP button.

**7 Follow your progress with the five displays and the TRAINING ZONE monitor.**

See TRAINING ZONE MONITOR on pages 12 and 13.

**8 When you are finished exercising, stop the walking belt and remove the key.**

Step onto the foot rails, stop the walking belt, and remove the key from the console. Store the key in a secure place. In addition, move the on/off switch to the "off" position. (See the drawing near the bottom of page 10.)

**HOW TO USE THE FITNESS TEST PROGRAM**

The FITNESS TEST program is designed to measure your relative fitness level. For the best results, the FITNESS TEST should be taken at a time when your energy level is high. The FITNESS TEST should not be taken if you have already exercised during the day.

The FITNESS TEST program consists of seven 4-minute periods, and is followed by a 2-minute cool-down period. The speed and/or incline of the treadmill will automatically increase at the beginning of each 4-minute period.

To use the FITNESS TEST program, follow the steps below.

**1 Make sure that the key is fully inserted into the console.**

Stand on the foot rails and insert the key. Various displays and indicators will light. Find the clip attached to the key, and slide it onto the waistband of your clothing.

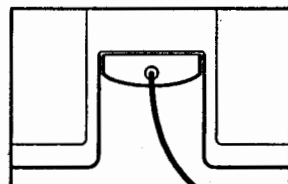

**2 Select the FITNESS TEST program.**

Press the FITNESS TEST button. The indicator beside the button will light. Note: If the walking belt is moving, it will slow to a stop.

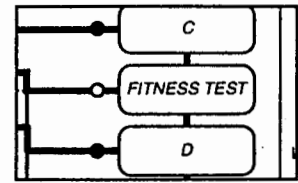

**3 Enter your weight.**

When the FITNESS TEST program is selected, the letters "Lbs" will flash in the CALORIES display. You must enter your weight and age before this program can be started. To enter your weight, see step 3 on page 11. If you have already entered your weight, you must press one of the WEIGHT buttons to verify the weight setting.

**4 Enter your age.**

After you have completed step 3, the letters "AGE" will flash in the PULSE display. To enter your age, see step 4 on page 11. If you have already entered your age, you must press one of the AGE buttons to verify the age setting.

**5 Put on the pulse sensor.**

The pulse sensor must be worn when the FITNESS TEST program is used. To put on the pulse sensor, see HOW TO USE THE PULSE

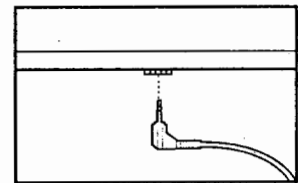

SENSOR on page 8. Plug the pulse sensor wire fully into the jack on the front of the console. Note: The FITNESS TEST program can be started without your pulse being detected; however, the program will automatically stop if your pulse is not detected 4 minutes after the program is started.

**6 Press the START/PAUSE button to start the program.**

When the START/PAUSE button is pressed, the TIME display will begin counting up. The CALORIES display will show "L 1" (level 1), indicating that the first 4-minute period of the FITNESS TEST program has begun. The incline of the treadmill will automatically adjust to 3.0%, and the walking belt will begin to move at 1.5 mph. Hold the handrails and carefully begin walking.

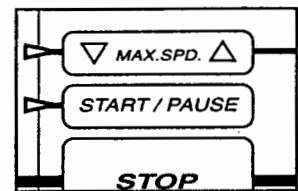

When the TIME display reaches 4 minutes, the CALORIES display will show "L 2," indicating that the second 4-minute period has begun. The incline will increase to 4%, and the speed will increase to 2.5 mph. At the beginning of each 4-minute period, the speed and/or incline of the treadmill will automatically increase. The FITNESS TEST will continue in this manner *until your pulse reaches 70% of your maximum heart rate, and the current 4-minute period is completed. The FITNESS TEST will then be completed, regardless of how many periods remain.*

When the FITNESS TEST program is completed, the letter "C" will be shown in the CALORIES display, indicating that the cool-down period has begun. The TIME display will count down from 2 minutes. When the cool-down period is completed, the walking belt will slow to a stop, and your fitness level will be shown in the TIME display. There are ten fitness levels—fitness level 10 (FL:10) is the highest. Remember, the FITNESS TEST is intended only to indicate your relative fitness level.

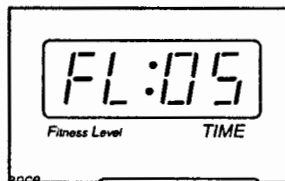

Note: The SPEED and INCLINE buttons will not respond while the FITNESS TEST program is selected. If your pulse is not detected during the program, the NO PULSE DETECTED indicator will light and the letters "PLS" will flash in the PULSE display. If your pulse is not detected during the last thirty seconds of any 4-minute period (after 4 minutes, after 8 minutes, etc.), the walking belt will slow to a stop, the FITNESS TEST will end, and the TIME display will show a fitness level of 0 (FL:00). (See GUIDELINES FOR ACCURATE PULSE READINGS on page 8.) The FITNESS TEST program can be stopped at any time by pressing the STOP button. The TIME display will then show an estimated fitness level. If the STOP button is pressed a second time, the MANUAL mode will be selected.

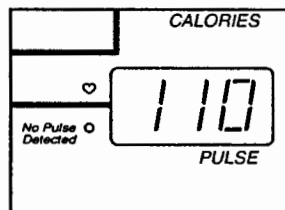

## 7 When you are finished exercising, stop the walking belt and remove the key.

Step onto the foot rails, stop the walking belt, and remove the key from the console. Store the key in a secure place. In addition, move the on/off switch to the "off" position. (See the drawing near the bottom of page 10.)

### HOW TO USE THE UPPER BODY ARMS

As you exercise on the treadmill, you can hold either the handrails or the upper body arms. The upper body arms are designed to exercise your arms, shoulders, and back for a total body workout. Hold one upper body arm with each hand, and move the arms forward and back as you walk on the treadmill.

To vary the intensity of your upper body exercise, the resistance of the upper body arms can be adjusted. To increase the resistance, turn the resistance knobs clockwise; to decrease the resistance, turn the knobs counter-clockwise.

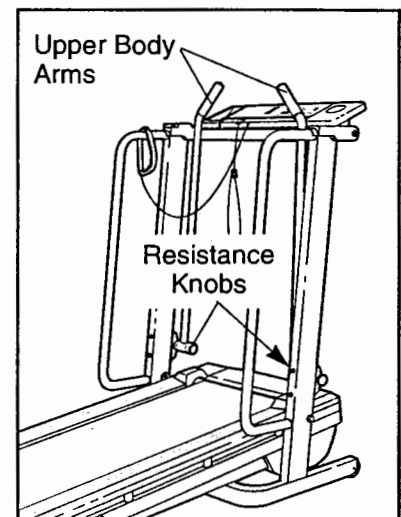

### HOW TO SELECT THE INFORMATION MODE

The console features an information mode that keeps track of the total time and distance accumulated on the treadmill.

To access the information mode, hold down the STOP button while inserting the key into the console. The TIME display will show the total time accumulated on the treadmill, in hours. The DISTANCE/INCLINE display will show the total distance, in miles (if the total distance exceeds 999, the thousands and ten thousands digits will be shown in the PULSE display). Note: The SPEED display will show an "E" (for English system—miles) or "M" (for Metric system—kilometers) (see SPEED DISPLAY on page 12).

To exit the information mode, remove the key.

RELEASED TO  
FEB 15  
MANUFACTURING

# HOW TO FOLD AND MOVE THE TREADMILL

## HOW TO FOLD THE TREADMILL FOR STORAGE

Before folding the treadmill for storage, unplug the power cord. To prevent damage to the pulse sensor, be sure to unplug the pulse sensor from the console. **Caution: You must be able to safely lift 45 pounds (20 kg) in order to raise, lower, or move the treadmill.**

1. Hold the treadmill with your hands in the locations shown at the right. To decrease the possibility of injury, bend your legs and keep your back straight. As you raise the treadmill, make sure to lift with your legs rather than your back. Raise the treadmill about halfway to the vertical position.

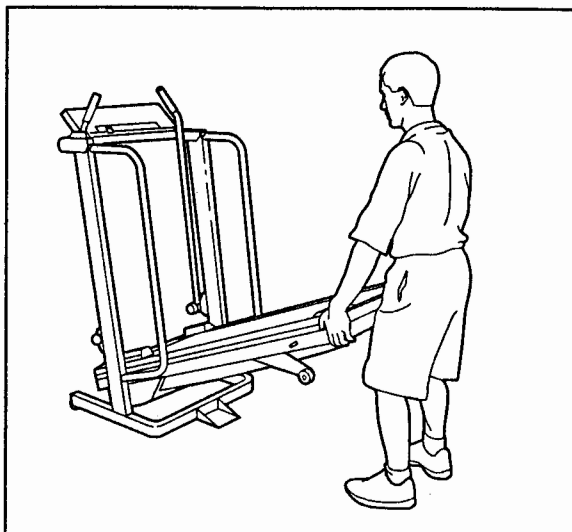

2. Move your right hand to the position shown at the right, and hold the treadmill firmly. Using your left hand, lift the storage latch. Raise the treadmill until the locking pin snaps into the storage latch. **Make sure that the locking pin is inside the storage latch, and that the storage latch is fully closed.**

To protect the floor or carpet from damage, place a mat under the treadmill. Keep the treadmill out of direct sunlight. Do not leave the treadmill in the storage position in temperatures above 85° Fahrenheit.

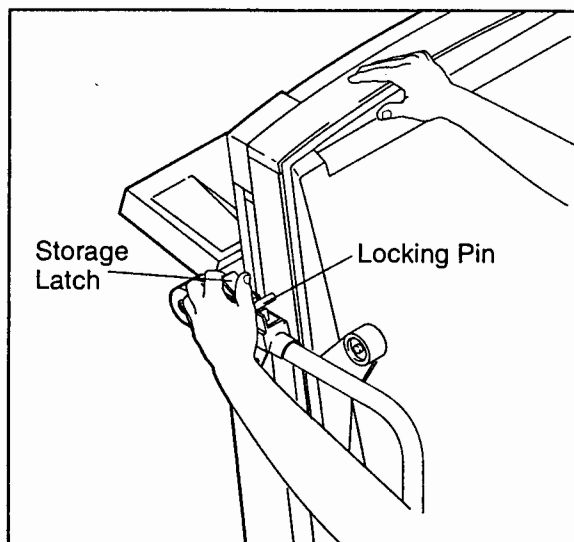

## HOW TO MOVE THE TREADMILL

Before moving the treadmill, convert the treadmill to the storage position as described above.

1. Hold one crossbar bracket with each hand. Place one foot on the base as shown.
2. Tilt the treadmill back until it rolls freely on the front wheels. Carefully move the treadmill to the desired location. To reduce the risk of injury, use extreme caution while moving the treadmill. Do not attempt to move the treadmill over an uneven surface.
3. Place one foot on the base crossbar, and carefully lower the treadmill until it is resting in the storage position.

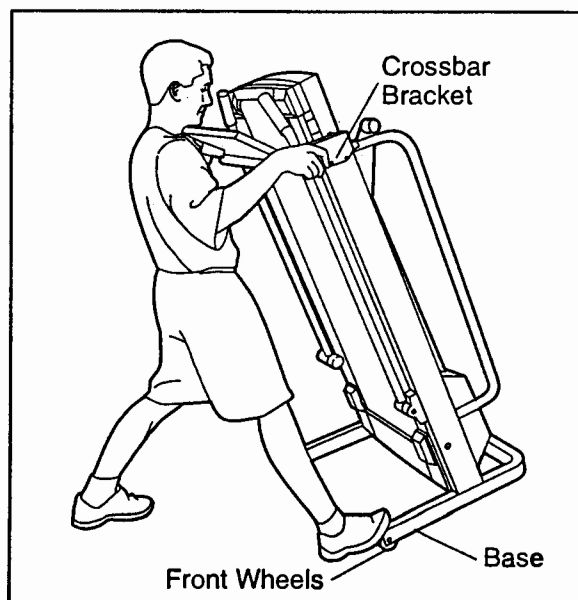

## HOW TO LOWER THE TREADMILL FOR USE

1. Hold the upper end of the treadmill with your right hand as shown. Using your left hand, lift the storage latch. Pivot the treadmill slightly until the locking pin is out of the storage latch. Close the storage latch.

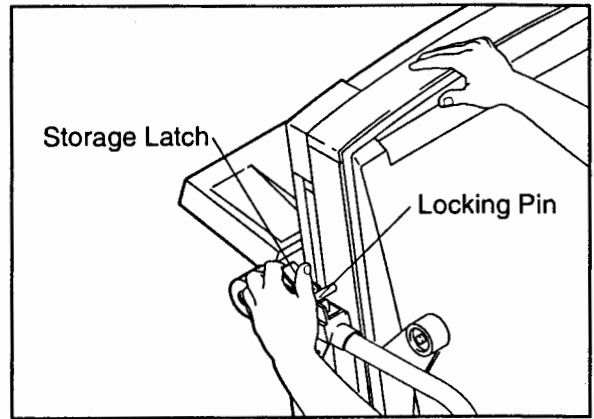

2. Hold the treadmill firmly with both hands, and lower the treadmill to the floor. **To decrease the possibility of injury, bend your legs and keep your back straight.**

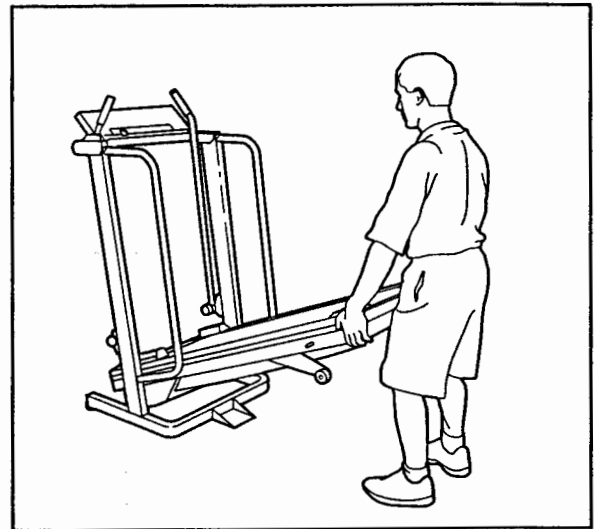



RELEASED TO  
FEB 15  
MANUFACTURING

# TROUBLE-SHOOTING

Most treadmill problems can be solved by following the steps below. Find the symptom that applies, and follow the steps listed.

If further assistance is needed, please call our Customer Service Department toll-free at 1-800-999-3756, Monday through Friday, 6 a.m. until 6 p.m. Mountain Time (excluding holidays).

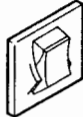
## 1. SYMPTOM: THE POWER DOES NOT TURN ON

- a. Make sure that the power cord is plugged into a surge protector, and that the surge protector is plugged into a properly grounded outlet. (See HOW TO PLUG IN THE POWER CORD on page 9.) Use only a UL-listed surge protector, rated at 15 amps, with a 14-gauge cord of five feet or less in length.
- b. After the power cord has been plugged in, make sure that the key is fully inserted into the console. Various indicators on the console should light. (See step 1 page 11.)
- c. Check the circuit breaker located on the treadmill near the power cord. If the switch protrudes as shown, the circuit breaker has tripped. To reset the circuit breaker, wait for five minutes and then press the switch back in.
- d. Check the on/off switch located at the front of the treadmill near the power cord. The switch must be in the "on" position.

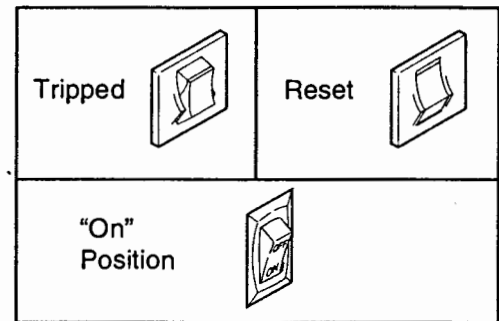

## 2. SYMPTOM: THE POWER TURNS OFF DURING USE

- a. Check the circuit breaker located on the treadmill near the power cord (see 1. c. above). If the circuit breaker has tripped, wait for five minutes and then press the switch back in.
- b. Make sure that the power cord is plugged in.
- c. Remove the key from the console, and reinsert it fully into the console. (See step 1 on page 11.)
- d. Check to make sure that the on/off switch is in the "on" position. (See 1. d. above.)
- e. If the treadmill still will not run, please call our Customer Service Department, toll-free.

## 3. SYMPTOM: THE WALKING BELT SLOWS WHEN WALKED ON

- a. Use only a UL-listed surge protector, rated at 15 amps, with a 14-gauge cord of five feet or less in length.
- b. If the walking belt still slows when walked on, please call our Customer Service Department, toll-free.

## 4. SYMPTOM: AN ERROR CODE ("E1," "E2," "E3," "E4," OR "E5") APPEARS ON THE CONSOLE

- a. If error code "E1" appears in the DISTANCE/INCLINE display, a malfunction may have occurred in the incline system. Remove the key, wait for ten seconds, and then reinsert it. If the error code appears again, call our toll-free Customer Service Department. Do not operate the treadmill until the problem is corrected.
- b. Error code "E2" may appear in the SPEED display if the SPEED increase or START/PAUSE button is pressed and no movement of the walking belt is detected within seven seconds. Remove the key, wait for ten seconds, and then reinsert it. Make sure that you stand on the foot rails of the treadmill each time you start the walking belt. If the error code appears again, call our toll-free Customer Service Department. Do not operate the treadmill until the problem is corrected.

- c. Error code "E3" may appear in the SPEED display if the speed of the walking belt surges above the selected speed setting. Remove the key, wait for ten seconds, and then reinsert it. If the error code appears again, call our toll-free Customer Service Department. Do not operate the treadmill until the problem is corrected.
- d. Error code "E4" may appear in the SPEED display if the walking belt is moving at a slow speed, and there is excessive stress on the motor. Remove the key, wait for ten seconds, and then reinsert it. If you weigh over 200 pounds, it may be helpful to increase the incline of the treadmill. If the error code appears again, call our toll-free Customer Service Department. Do not operate the treadmill until the problem is corrected.
- e. Error code "E5" may appear in the PULSE display if a pulse error occurs. See HOW TO USE THE PULSE SENSOR on page 8, and PULSE DISPLAY on page 12.

**5. SYMPTOM: THE PULSE SENSOR DOES NOT FUNCTION PROPERLY**

- a. See HOW TO USE THE PULSE SENSOR on page 8, and PULSE DISPLAY on page 12.

**6. SYMPTOM: THE WALKING BELT IS OFF-CENTER OR SLIPS WHEN WALKED ON**

- a. If the walking belt has shifted to the left, first remove the key and **UNPLUG THE POWER CORD**. Using the 3/16" allen wrench, turn the left rear roller adjustment bolt clockwise 1/4 of a turn. Plug in the power cord, insert the key and run the treadmill for a few minutes. Repeat until the walking belt is centered.

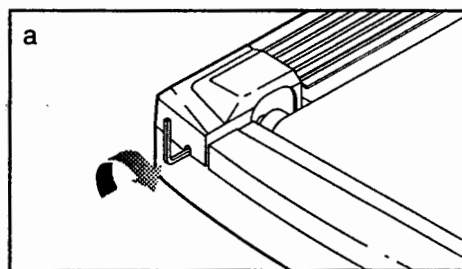

- b. If the walking belt has shifted to the right, first remove the key and **UNPLUG THE POWER CORD**. Using the 3/16" allen wrench, turn the left rear roller adjustment bolt counterclockwise 1/4 of a turn. Plug in the power cord, insert the key and run the treadmill for a few minutes. Repeat until the walking belt is centered.

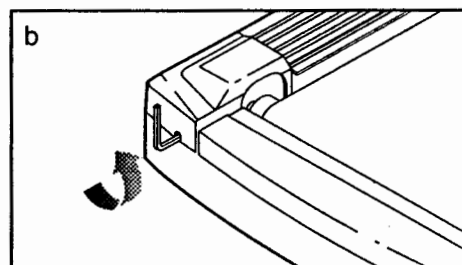

**7. SYMPTOM: ONE OF THE UPPER BODY ARMS SQUEAKS DURING USE**

- a. Correcting this problem requires a small amount of white marine grease, available at most department stores.

Turn the Resistance Knob (59) counterclockwise until it can be removed. Remove the Resistance Cone (60) and the Upper Body Arm (12), along with the 3/8" Washers (65), Spring Washer (62), Thrust Washers (63), and Thrust Bearing (64). (Note: If the Resistance Sleeve [61] comes out of the Resistance Bracket [66], press it back in.) Apply a **thin layer** of white marine grease to the outer surface of the Resistance Cone (60). Reattach all parts in the order shown at the right.

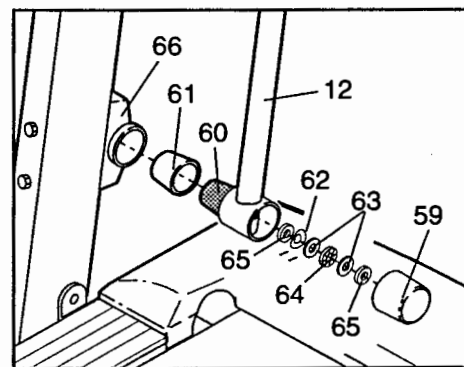

RELEASED TO  
FEB 15  
MANUFACTURING

# CONDITIONING GUIDELINES

**⚠ WARNING:** Before beginning this or any exercise program, consult your physician. This is especially important for individuals over the age of 35 or individuals with pre-existing health problems.

The pulse sensor is not a medical device. Various factors, including your movement, may affect the accuracy of heart rate readings. The sensor is intended only as an exercise aid in determining heart rate trends in general.

The following guidelines will help you to plan your exercise program. Remember—these are general guidelines. For more detailed information about exercise, obtain a reputable book or consult your physician.

## EXERCISE INTENSITY

Whether you want to burn fat, strengthen your cardiovascular system, or increase your athletic performance, you can tailor your exercise to your specific goals. The key to achieving the desired results is to exercise with the proper intensity.

### Burning Fat

To burn fat effectively, you must exercise at a relatively low intensity level for a sustained period of time. During the first few minutes of exercise, your body uses easily accessible *carbohydrate calories* for energy. Only after the first few minutes of exercise does your body begin to use stored *fat calories* for energy. If your goal is to burn fat, adjust the speed and incline of the treadmill until the FAT BURN indicator is lit. (See TRAINING ZONE MONITOR on pages 12 and 13.)

### Aerobic Exercise

If your goal is to strengthen your cardiovascular system, your exercise must be "aerobic." Aerobic exercise is activity that requires large amounts of oxygen for prolonged periods of time. This increases the demand on the heart to pump blood to the muscles, and on the lungs to oxygenate the blood. The proper intensity level for aerobic exercise can be found by using your pulse as a guide. As you exercise, your pulse should be kept at a level between 70% and 85% of your maximum possible heart rate. This is known as your training zone. You can find your training zone in the table at the top of this page. Training zones are listed according to age and physical condition.

Age	Training Zone (Beats/Min.)	
	Unconditioned	Conditioned
20	138-167	133-162
25	136-166	132-160
30	135-164	130-158
35	134-162	129-156
40	132-161	127-155
45	131-159	125-153
50	129-156	124-150
55	127-155	122-149
60	126-153	121-147
65	125-151	119-145
70	123-150	118-144
75	122-147	117-142
80	120-146	115-140
85	118-144	114-139

keep your pulse near the low end of your training zone as you exercise. After a few months of regular exercise, your pulse can be gradually increased until it is near the middle of your training zone as you exercise. You can measure your pulse using the pulse sensor. Exercise for about four minutes, and then measure your pulse immediately. If your pulse is too high or too low, adjust the intensity of your exercise. It may also be helpful to adjust the speed and incline of the treadmill until the AEROBIC indicator is lit. (See TRAINING ZONE MONITOR on pages 12 and 13.)

### Performance Training

If your goal is high performance athletic conditioning, adjust the speed and incline of the treadmill until the PERFORMANCE indicator is lit. (See TRAINING ZONE MONITOR on pages 12 and 13.)

## WORKOUT GUIDELINES

Each workout should include three parts: (1) a warm-up, (2) training zone exercise, and (3) a cool-down.

### Warm-up

Warming up prepares the body for exercise by increasing circulation, delivering more oxygen to the muscles and raising the body temperature. Begin each workout with 5 to 10 minutes of stretching and light exercise to warm up (see SUGGESTED STRETCHES on page 23).

RELEASED  
FEB 15  
MANUF

## Training Zone Exercise

After warming up, increase the intensity of your exercise until your pulse is in your training zone for 20 to 60 minutes. (During the first few weeks of your exercise program, do not keep your pulse in your training zone for longer than 20 minutes.) Breathe regularly and deeply as you exercise—never hold your breath.

## Cool-down

Finish each workout with 5 to 10 minutes of stretching

to cool down. This will increase the flexibility of your muscles and will help to prevent post-exercise problems.

## Exercise Frequency

To maintain or improve your condition, complete three workouts each week, with at least one day of rest between workouts. After a few months, you may complete up to five workouts each week if desired.

*The key to success is to make exercise a regular and enjoyable part of your everyday life.*

## SUGGESTED STRETCHES

The correct form for several basic stretches is shown in the drawings below. Move slowly as you stretch—never bounce.

### 1. Toe Touch Stretch

Stand with your knees bent slightly and slowly bend forward from your hips. Allow your back and shoulders to relax as you reach down toward your toes as far as possible. Hold for 15 counts, then relax. Repeat 3 times. Stretches: Hamstrings, back of knees and back.

### 2. Hamstring Stretch

Sit with one leg extended. Bring the sole of the opposite foot toward you and rest it against the inner thigh of your extended leg. Reach toward your toes as far as possible. Hold for 15 counts, then relax. Repeat 3 times for both legs. Stretches: Hamstrings, lower back and groin.

### 3. Calf/Achilles Stretch

With one leg in front of the other, reach forward and place your hands against a wall. Keep your back leg straight and your back foot flat on the floor. Bend your front leg, lean forward and move your hips toward the wall. Hold for 15 counts, then relax. Repeat 3 times for both legs. To cause further stretching of the achilles tendons, bend your back leg as well. Stretches: Calves, achilles tendons and ankles.

### 4. Quadriceps Stretch

With one hand against a wall for balance, reach back and grasp one foot with your other hand. Bring your heel as close to your buttocks as possible. Hold for 15 counts, then relax. Repeat 3 times for both legs. Stretches: Quadriceps and hip muscles.

### 5. Inner Thigh Stretch

Sit with the soles of your feet together and your knees outward. Pull your feet toward your groin area as far as possible. Hold for 15 counts, then relax. Repeat 3 times. Stretches: Quadriceps and hip muscles.

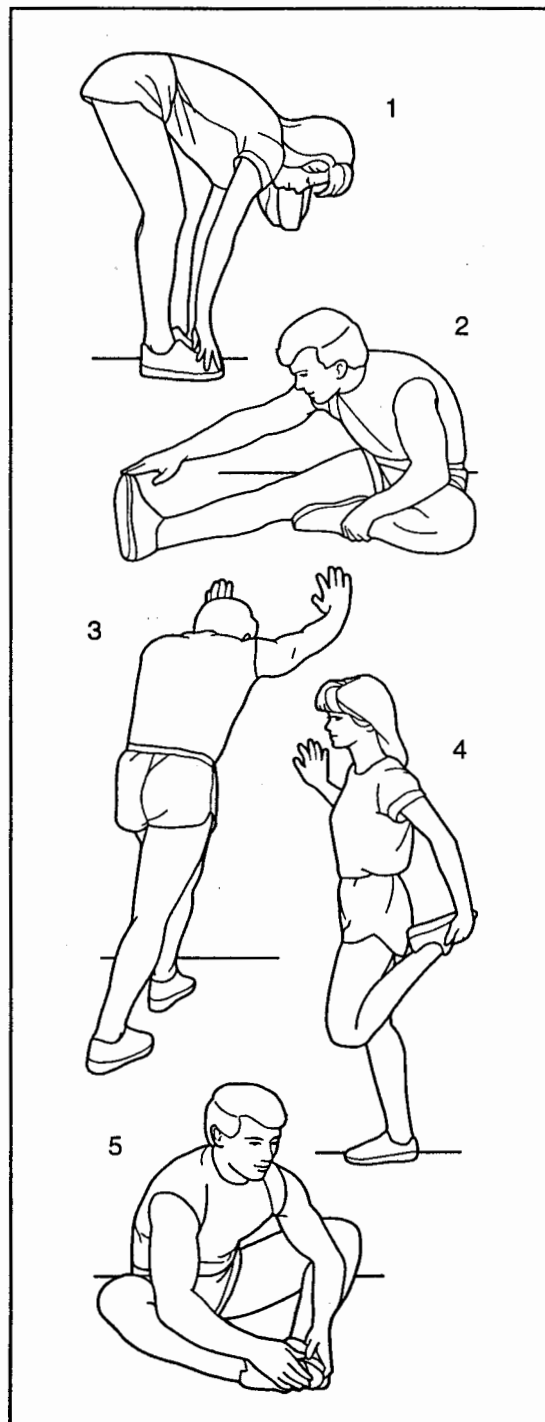

# ORDERING REPLACEMENT PARTS

To order replacement parts, call our Customer Service Department toll-free at 1-800-999-3756, Monday through Friday, 6 a.m. until 6 p.m. Mountain Time (excluding holidays). When ordering parts, please be prepared to give the following information:

- The MODEL NUMBER OF THE PRODUCT (PFTL20860).
- The NAME OF THE PRODUCT (PROFORM® 785xt treadmill).
- The SERIAL NUMBER OF THE PRODUCT (see the front cover of this manual).
- The KEY NUMBER OF THE PART(S) (see the EXPLODED DRAWING and PART LIST attached to the center of this manual).
- The DESCRIPTION OF THE PART(S) (see the EXPLODED DRAWING and PART LIST attached to the center of this manual).

If possible, place the treadmill near your telephone for easy reference when calling.

## LIMITED WARRANTY

ICON Health & Fitness, Inc. ("ICON"), warrants this product to be free from defects in workmanship and material, under normal use and service conditions, for a period of ninety (90) days from the date of purchase. This warranty extends only to the original purchaser. ICON's obligation under this warranty is limited to replacing or repairing, at ICON's option, the product at one of its authorized service centers. All products for which warranty claim is made must be received by ICON at one of its authorized service centers with all freight and other transportation charges prepaid, accompanied by sufficient proof of purchase. All returns must be pre-authorized by ICON. This warranty does not extend to any product or damage to a product caused by or attributable to freight damage, abuse, misuse, improper or abnormal usage or repairs not provided by an ICON authorized service center, to products used for commercial or rental purposes, or to products used as store display models. No other warranty beyond that specifically set forth above is authorized by ICON.

ICON IS NOT RESPONSIBLE OR LIABLE FOR INDIRECT, SPECIAL OR CONSEQUENTIAL DAMAGES ARISING OUT OF OR IN CONNECTION WITH THE USE OR PERFORMANCE OF THE PRODUCT OR OTHER DAMAGES WITH RESPECT TO ANY ECONOMIC LOSS, LOSS OF PROPERTY, LOSS OF REVENUES OR PROFITS, LOSS OF ENJOYMENT OR USE, COSTS OF REMOVAL, INSTALLATION OR OTHER CONSEQUENTIAL DAMAGES OF WHATSOEVER NATURE. SOME STATES DO NOT ALLOW THE EXCLUSION OR LIMITATION OF INCIDENTAL OR CONSEQUENTIAL DAMAGES. ACCORDINGLY, THE ABOVE LIMITATION MAY NOT APPLY TO YOU.

THE WARRANTY EXTENDED HEREUNDER IS IN LIEU OF ANY AND ALL OTHER WARRANTIES AND ANY IMPLIED WARRANTIES OF MERCHANTABILITY OR FITNESS FOR A PARTICULAR PURPOSE IS LIMITED IN ITS SCOPE AND DURATION TO THE TERMS SET FORTH HEREIN. SOME STATES DO NOT ALLOW LIMITATIONS ON HOW LONG AN IMPLIED WARRANTY LASTS. ACCORDINGLY, THE ABOVE LIMITATION MAY NOT APPLY TO YOU.

This warranty gives you specific legal rights. You may also have other rights which vary from state to state.

**ICON HEALTH & FITNESS, INC., 1500 S. 1000 W., LOGAN, UT 84321-9813**

# REMOVE THIS EXPLODED DRAWING AND PART LIST FROM THE MANUAL

Save this EXPLODED DRAWING and PART LIST for future reference.

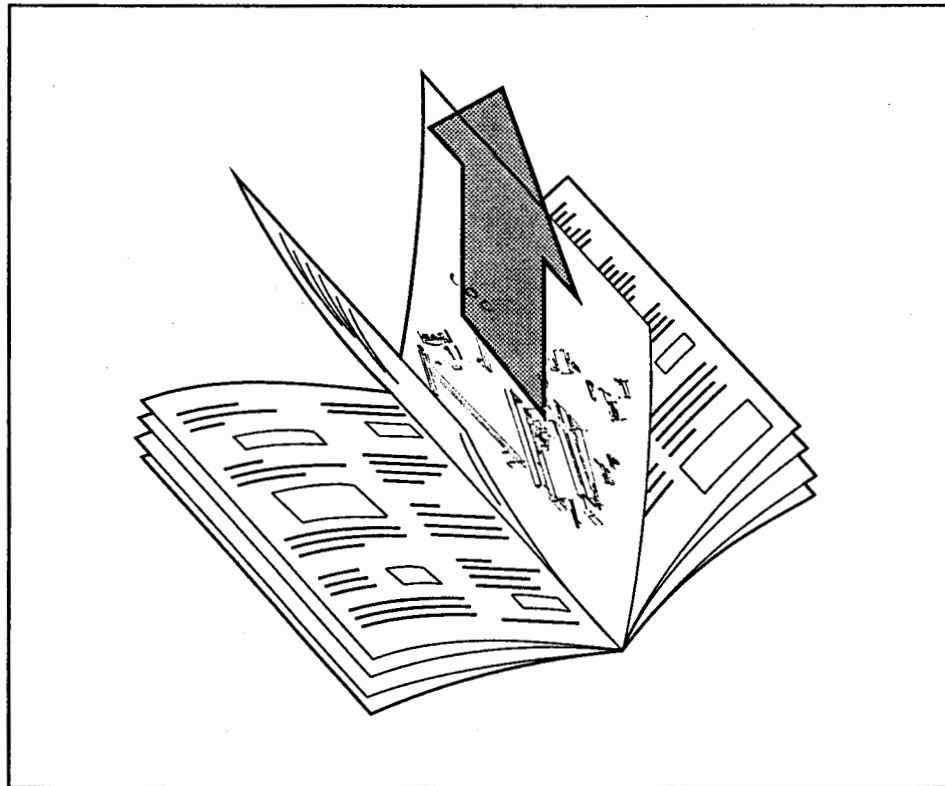

Note: Specifications are subject to change without notice. For information about ordering replacement parts, see the back cover of this manual.

USED TO

EB15

MANUFACTURING

EXPLODED DRAWING—Model No. PFTL20860

RD296A

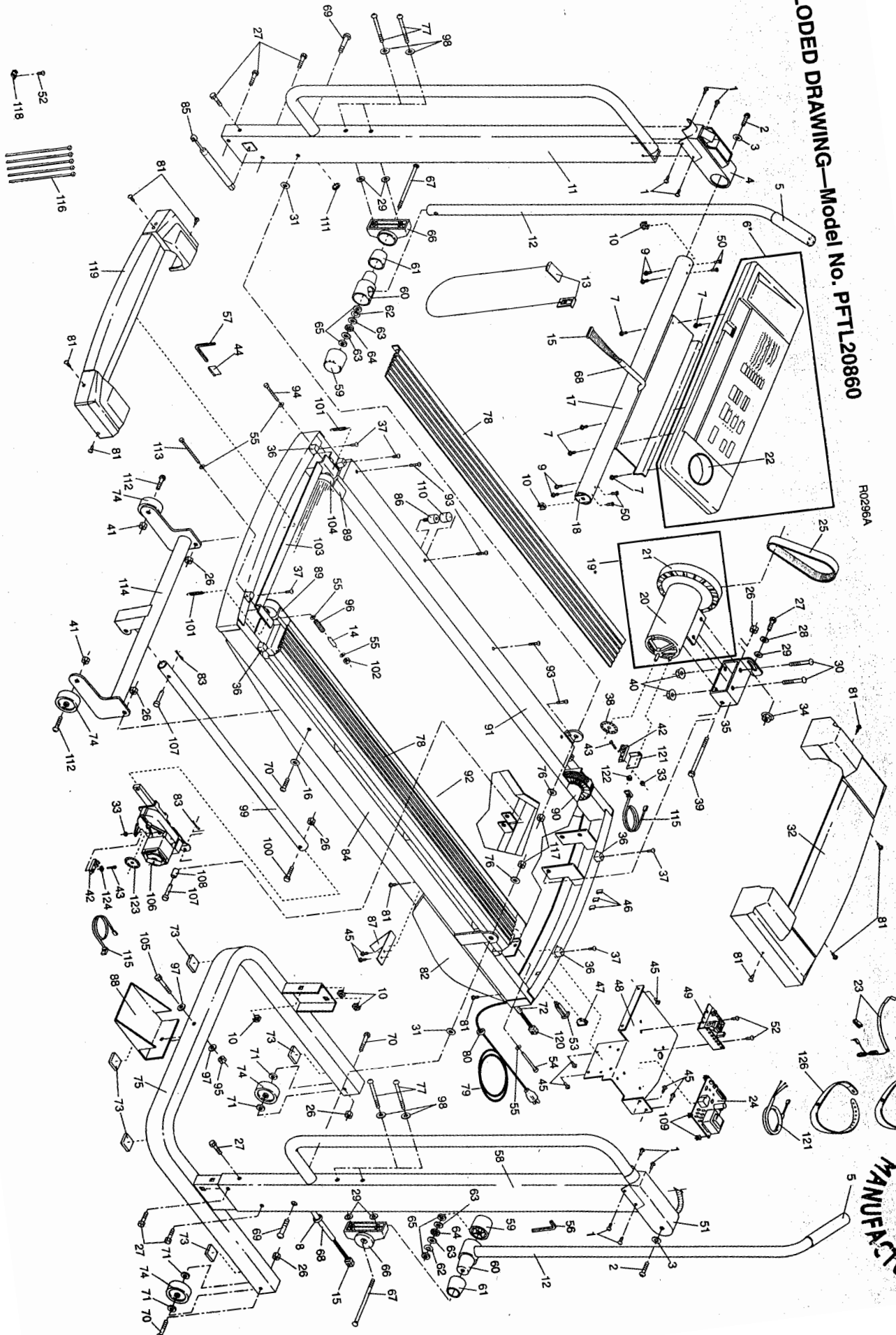

RELEASED  
FEB 15  
MANUFACTURING

# PART LIST—Model No. PFTL20860

R0296A

Key No.	Qty.	Description	Key No.	Qty.	Description
1	8	Crossbar Bracket Screw	70	4	Front Wheel Bolt/Pivot Bolt
2	2	Crossbar Bolt	71	4	Wheel Spacer
3	2	Crossbar Washer	72	1	6" Cable Loom
4	1	Left Crossbar Bracket	73	5	Upright Foot
5	2	Foam Grip	74	4	Wheel
6*	1	Console	75	1	Base
7	13	Console Screw	76	2	Upright Pivot Washer
8	1	Wire Harness Grommet	77	4	Resistance Bracket Bolt
9	4	Crossbar Screw	78	2	Foot Rail
10	8	Cage Nut	79	1	Power Cord
11	1	Left Upright	80	1	Grommet
12	2	Upper Body Arm w/Foam	81	30	Safety Cover Screw/Hood Screw
13	1	Key/Clip	82	1	Safety Cover
14	1	Spring Sleeve	83	2	Hairpin Cotter Pin
15	1	Pot Wire Harness	84	1	Frame
16	2	Incline Leg Pivot Washer	85	1	Base Shock
17	1	Console Crossbar	86	8	Isolator
18	2	Crossbar Bracket	87	2	Belt Guide
19*	1	Motor/Pulley/Flywheel/Fan	88	1	Stabilizer Plate
20	1	Motor	89	2	Roller Guard
21	1	Pulley/Flywheel/Fan	90	1	Front Roller/Pulley
22	1	Water Bottle Holder Insert	91	1	Walking Platform
23	1	Pulse Sensor/Clothes Clip	92	1	Walking Belt
24	1	Power Supply w/Clip	93	8	Platform Screw
25	1	Motor Belt	94	1	Left Rear Roller Adj. Bolt
26	6	Nut	95	1	Stabilizer Plate Nut
27	7	Motor Tension Bolt/Upright Bolt	96	1	Tension Spring
28	1	Motor Tension Washer	97	2	Stabilizer Plate Washer
29	5	Star Washer	98	4	Resistance Bracket Washer
30	2	Motor Bolt	99	1	Incline Rod
31	2	Flat Washer	100	1	Incline Rod Bolt
32	1	Front Hood	101	2	Guard Spring
33	1	Small Nut	102	1	Roller Tension Nut
34	1	Motor Tension Nut	103	1	Rear Roller Guard
35	1	Motor Mount Bracket	104	1	Rear Roller
36	8	Rubber Hood Anchor	105	1	Stabilizer Plate Bolt
37	8	Anchor Screw	106	1	Incline Motor
38	1	Speed Disk	107	2	Cotter Pin
39	1	Motor Swivel Bolt	108	2	Incline Motor Spacer
40	2	Motor Nut	109	4	Plastic Stand-Off
41	2	Incline Leg Wheel Nut	110	8	Isolator Cover
42	2	Optic Switch	111	1	Upright Plug
43	2	Small Bolt	112	2	Incline Wheel Bolt
44	1	Adhesive Clip	113	1	Right Rear Roller Adj. Bolt
45	9	Screw	114	2	Incline Leg
46	3	Wire Clip	115	2	Optic Switch Wire Harness
47	1	On/Off Switch	116	2	8" Wire Tie
48	1	Electronics Bracket	117	2	Upright Pivot Nut
49	1	Controller	118	1	Tie Holder Clamp
50	4	Crossbar Bracket Screw	119	1	Rear Hood
51	1	Right Crossbar Bracket	120	1	Short Wire Harness
52	6	Controller Screw/Ground Screw	121	1	Optic Switch
53	1	Circuit Breaker	122	1	Optic Switch Nut
54	1	Front Roller Adjustment Bolt	123	1	Incline Disk
55	5	Adjustment Washer	124	1	Star Washer
56	1	7/32" Allen Wrench	125	1	Red Headband
57	1	3/16" Allen Wrench	126	1	Blue Headband
58	1	Right Upright	#	1	14" Blue Wire, 2 Female
59	2	Resistance Knob	#	1	8" Blue Wire, Male/Female
60	2	Resistance Cone	#	1	8" Blue Wire, 2 Female
61	2	Resistance Sleeve	#	1	8" White Wire, Male/Female
62	2	Spring Washer	#	1	14" White Wire, 2 Female
63	4	Thrust Washer	#	1	4" Black Wire, 2 Female
64	2	Thrust Bearing	#	1	8" Green Ground Wire
65	4	3/8" Flat Washer	#	1	26" Green Wire, Ring/Female
66	2	Resistance Bracket	#	1	70" Green Wire, Ring/Female
67	2	Resistance Bolt	#	1	User's Manual
68	1	Cable Loom			
69	2	Upright Pivot Bolt			

\* Includes all parts shown in the box

# These parts are not illustrated

REI