

# PRO-FORM<sup>®</sup>

## 425 CT

[www.proform.com](http://www.proform.com)

Model No. PFTL49612.1

Serial No. \_\_\_\_\_

Write the serial number in the space above for reference.

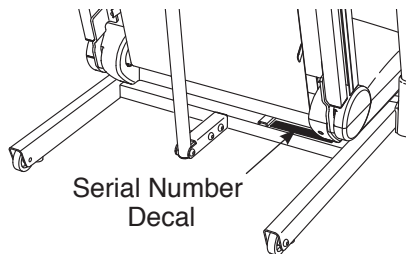

## USER'S MANUAL

### QUESTIONS?

If you have questions, or if parts are damaged or missing, **DO NOT CONTACT THE STORE**; please contact Customer Care.

**IMPORTANT:** Please register this product (see the limited warranty on the back cover of this manual) before contacting Customer Care.

CALL TOLL-FREE:

**1-888-533-1333**

Mon.–Fri. 6 a.m.–6 p.m. MT

Sat. 8 a.m.–4 p.m. MT

ON THE WEB:

[www.proformservice.com](http://www.proformservice.com)

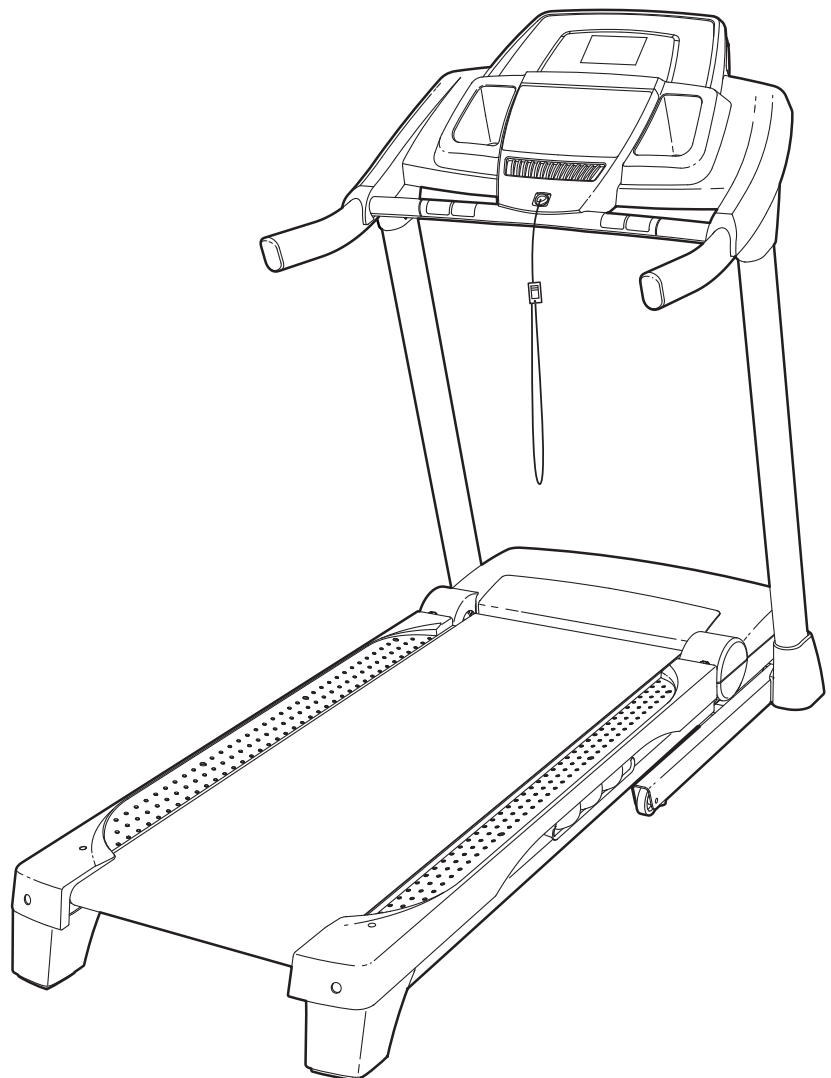

### CAUTION

Read all precautions and instructions in this manual before using this equipment. Save this manual for future reference.



# TABLE OF CONTENTS

WARNING DECAL PLACEMENT ..... 2

IMPORTANT PRECAUTIONS ..... 3

BEFORE YOU BEGIN ..... 5

PART IDENTIFICATION CHART ..... 6

ASSEMBLY ..... 7

OPERATION AND ADJUSTMENT ..... 15

HOW TO FOLD AND MOVE THE TREADMILL ..... 22

TROUBLESHOOTING ..... 23

EXERCISE GUIDELINES ..... 26

PART LIST ..... 27

EXPLODED DRAWING ..... 28

ORDERING REPLACEMENT PARTS ..... Back Cover

LIMITED WARRANTY ..... Back Cover



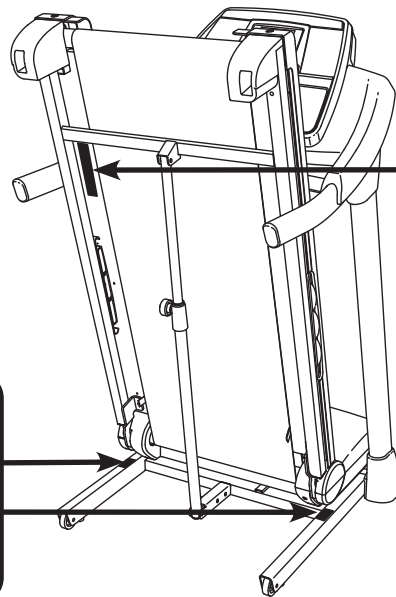

## WARNING DECAL PLACEMENT

This drawing shows the locations of the warning decals. **If a decal is missing or illegible, call the telephone number on the front cover of this manual and request a free replacement decal. Apply the decal in the location shown.** Note: The decals may not be shown at actual size.



**⚠ WARNING:**

Protect yourself and others from risk of serious injury. Read the user's manual and:

-  • Stand only on the side rails when starting or stopping treadmill.
- Change speed in small increments.
- Hold handrails to prevent falling, and always wear the safety clip while operating treadmill.
- Stop if you feel faint, dizzy, or short of breath.
- Fully engage storage latch before treadmill is moved or stored.
- Reduce incline to its lowest level before folding treadmill into storage position.
-  • Never allow children on or around treadmill.
- Remove key when not in use.
-  • Keep clothing, fingers, and hair away from moving belt.
- Never try to adjust or fix the belt while it is moving.
-  • Always wear athletic shoes while operating treadmill.

# IMPORTANT PRECAUTIONS

**⚠️ WARNING:** To reduce the risk of burns, fire, electric shock, or injury to persons, read all important precautions and instructions in this manual and all warnings on your treadmill before using your treadmill. ICON assumes no responsibility for personal injury or property damage sustained by or through the use of this product.

1. It is the responsibility of the owner to ensure that all users of this treadmill are adequately informed of all warnings and precautions.
2. Before beginning any exercise program, consult your physician. This is especially important for persons over age 35 or persons with pre-existing health problems.
3. Use the treadmill only as described in this manual.
4. The treadmill is intended for home use only. Do not use the treadmill in any commercial, rental, or institutional setting.
5. Keep the treadmill indoors, away from moisture and dust. Do not put the treadmill in a garage or covered patio, or near water.
6. Place the treadmill on a level surface, with at least 8 ft. (2.4 m) of clearance behind it and 2 ft. (0.6 m) on each side. Do not place the treadmill on any surface that blocks air openings. To protect the floor or carpet from damage, place a mat under the treadmill.
7. Do not operate the treadmill where aerosol products are used or where oxygen is being administered.
8. Keep children under age 12 and pets away from the treadmill at all times.
9. The treadmill should be used only by persons weighing 300 lbs. (136 kg) or less.
10. Never allow more than one person on the treadmill at a time.
11. Wear appropriate exercise clothes while using the treadmill. Do not wear loose clothes that could become caught in the treadmill. Athletic support clothes are recommended for both men and women. *Always wear athletic shoes. Never use the treadmill with bare feet, wearing only stockings, or in sandals.*
12. Plug the power cord into a surge suppressor (not included), and plug the surge suppressor into an appropriate outlet (see page 15). To avoid overloading the circuit, do not plug other electrical devices, except for low-power devices such as cell phone chargers, into the surge suppressor or into an outlet on the same circuit.
13. Use only a surge suppressor that meets all of the specifications described on page 15. To purchase a surge suppressor, see your local PROFORM dealer, call the telephone number on the front cover of this manual, or see your local electronics store.
14. Failure to use a properly functioning surge suppressor could result in damage to the control system of the treadmill. If the control system is damaged, the walking belt may slow, accelerate, or stop unexpectedly, which may result in a fall and serious injury.
15. Keep the power cord and the surge suppressor away from heated surfaces.
16. Never move the walking belt while the power is turned off. Do not operate the treadmill if the power cord or plug is damaged, or if the treadmill is not working properly. (See TROUBLESHOOTING on page 23 if the treadmill is not working properly.)
17. Read, understand, and test the emergency stop procedure before using the treadmill (see HOW TO TURN ON THE POWER on page 17).
18. Never start the treadmill while you are standing on the walking belt. Always hold the handrails while using the treadmill.
19. The treadmill is capable of high speeds. Adjust the speed in small increments to avoid sudden jumps in speed.
20. The heart rate monitor is not a medical device. Various factors, including the user's

movement, may affect the accuracy of heart rate readings. The heart rate monitor is intended only as an exercise aid in determining heart rate trends in general.

21. Never leave the treadmill unattended while it is running. Always remove the key, press the power switch into the off position (see the drawing on page 5 for the location of the power switch), and unplug the power cord when the treadmill is not in use.
22. Do not attempt to move the treadmill until it is properly assembled. (See ASSEMBLY on page 7, and HOW TO FOLD AND MOVE THE TREADMILL on page 22.) You must be able to safely lift 45 lbs. (20 kg) to raise, lower, or move the treadmill.
23. When folding or moving the treadmill, make sure that the storage latch is holding the frame securely in the storage position.

24. Never insert any object into any opening on the treadmill.

25. Inspect and properly tighten all parts of the treadmill regularly.

26. **DANGER:** Always unplug the power cord immediately after use, before cleaning the treadmill, and before performing the maintenance and adjustment procedures described in this manual. Never remove the motor hood unless instructed to do so by an authorized service representative. Servicing other than the procedures in this manual should be performed by an authorized service representative only.

27. Over exercising may result in serious injury or death. If you feel faint or if you experience pain while exercising, stop immediately and cool down.

**SAVE THESE INSTRUCTIONS**

# BEFORE YOU BEGIN

Thank you for selecting the new PROFORM® 425 CT treadmill. The 425 CT treadmill offers an impressive selection of features designed to make your workouts at home more enjoyable and effective. And when you're not exercising, the unique treadmill can be folded up, requiring less than half the floor space of other treadmills.

**For your benefit, read this manual carefully before using the treadmill.** If you have questions after

reading this manual, please see the front cover of this manual. To help us assist you, please note the product model number and serial number before contacting us. The model number and the location of the serial number decal are shown on the front cover of this manual.

Before reading further, please review the drawing below and familiarize yourself with the labeled parts.

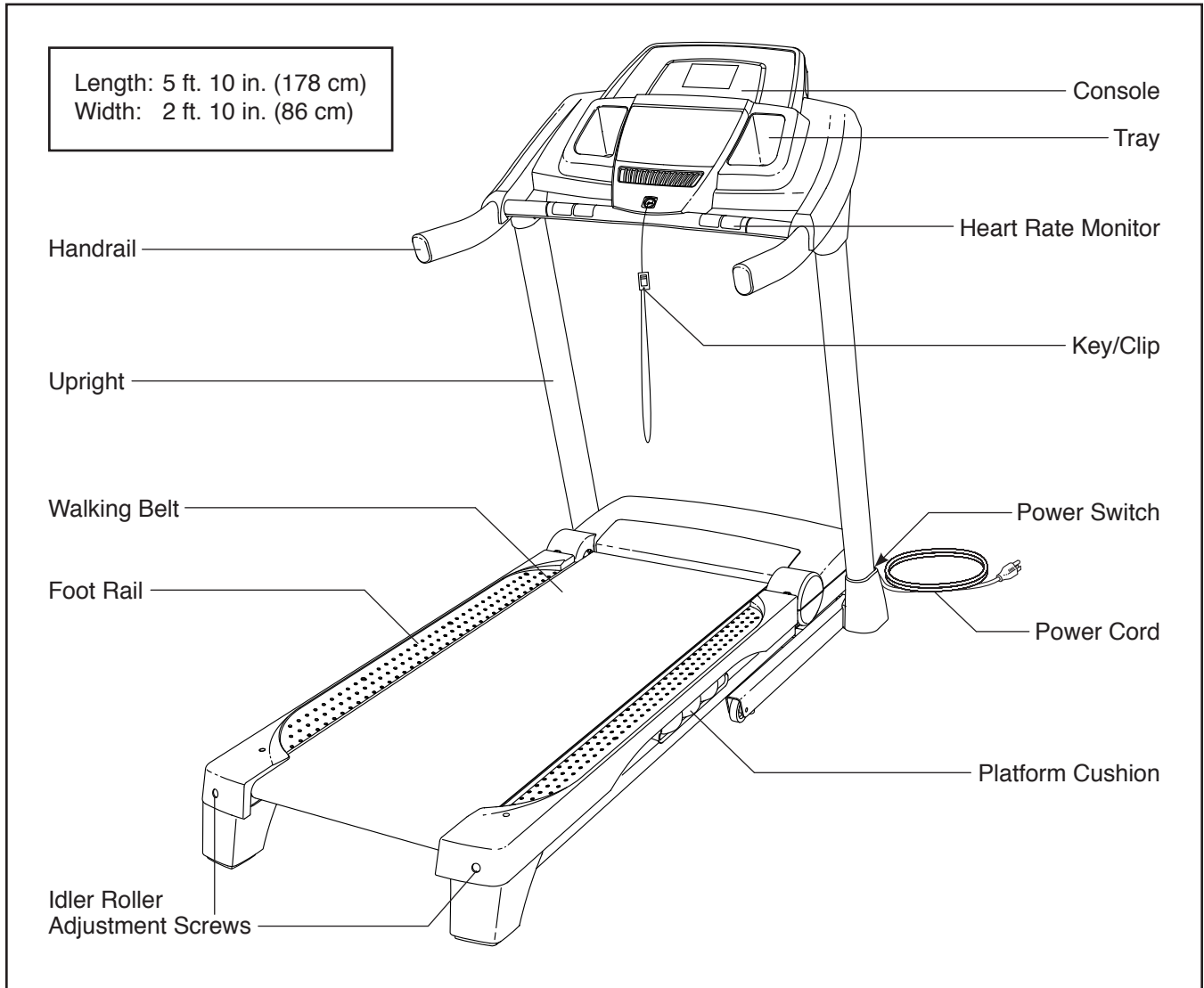

# PART IDENTIFICATION CHART



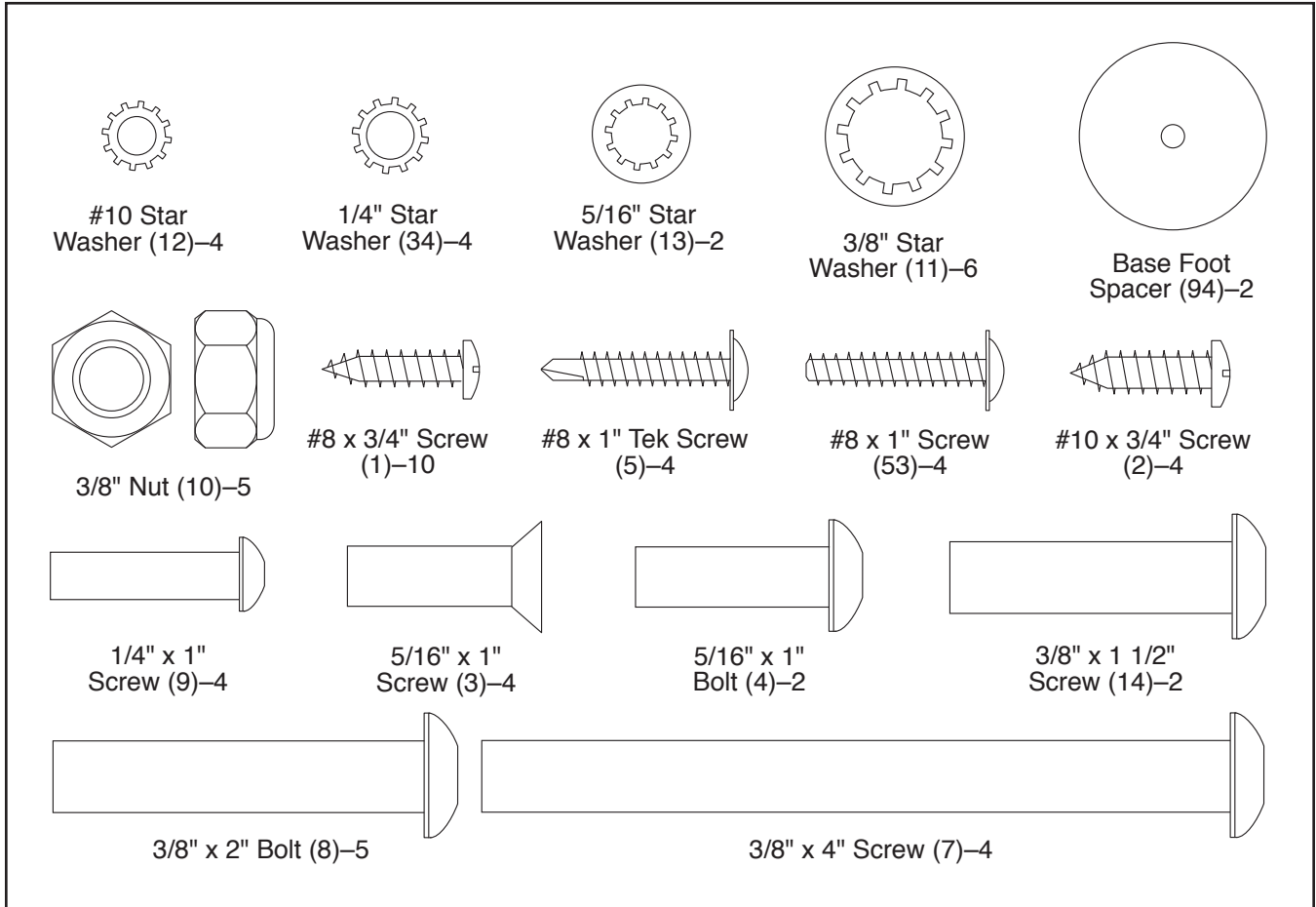

Use the drawings below to identify small parts used for assembly. The number in parentheses below each drawing is the key number of the part, from the PART LIST near the end of this manual. The number following the key number is the quantity used for assembly. **Note: If a part is not in the hardware kit, check to see if it is pre-attached. Extra parts may be included.**

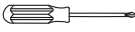

# ASSEMBLY

- To hire an authorized service technician to assemble the treadmill, call 1-800-445-2480.
- Assembly requires two persons.
- Place all parts in a cleared area and remove the packing materials. Do not dispose of the packing materials until you finish all assembly steps.
- After shipping, there may be an oily substance on the exterior of the treadmill. This is normal. If there is an oily substance on the treadmill, wipe it off with a soft cloth and a mild, non-abrasive cleaner.
- Left parts are marked "L" or "Left" and right parts are marked "R" or "Right."

- To identify small parts, see page 6.
- Assembly requires the following tools:

the included hex key	
one Phillips screwdriver	
one adjustable wrench	
needlenose pliers	
scissors	

To avoid damaging parts, do not use power tools.

## 1. Make sure that the power cord is unplugged.

With the help of a second person, carefully tip the treadmill onto its left side. Partially fold the Frame (55) so that the treadmill is more stable; **do not fully fold the Frame yet.**

Cut the shipping tie securing the Upright Wire (87) to the Base (95). Locate a plastic tie in the indicated hole in the Base, and use the tie to pull the Upright Wire out of the hole.

Attach two Base Feet (90) to the Base (95) in the locations shown with two #8 x 1" Tek Screws (5) and two Base Foot Spacers (94).

Then, attach the other two Base Feet (90) with two #8 x 1" Tek Screws (5).

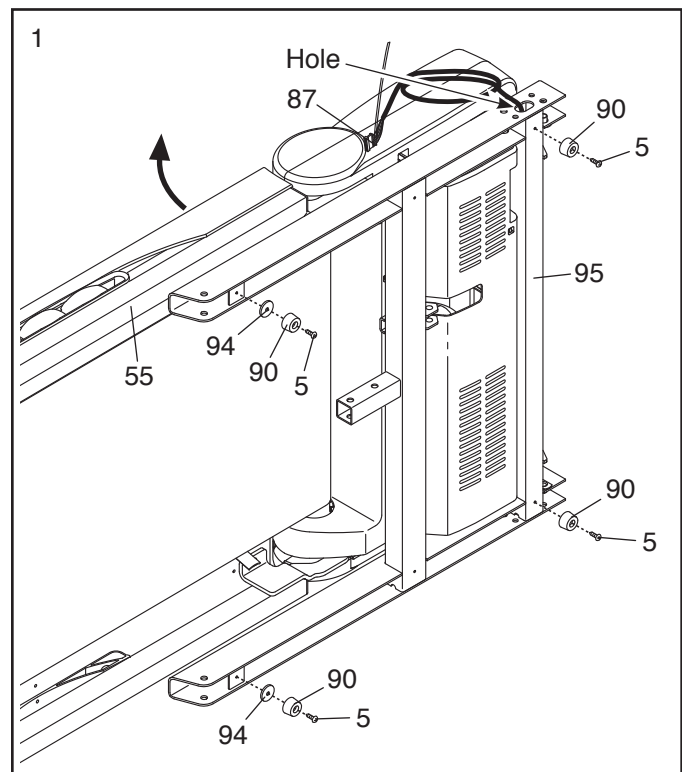

2. **See the inset drawing.** Cut the plastic tie near the Upright Wire (87).

Attach a Wheel (96) to the Base (95) with a 3/8" x 2" Bolt (8) and a 3/8" Nut (10). **Do not overtighten the Nut; the Wheel must turn freely.**

Press a Base Cap (89) into the Base (95).

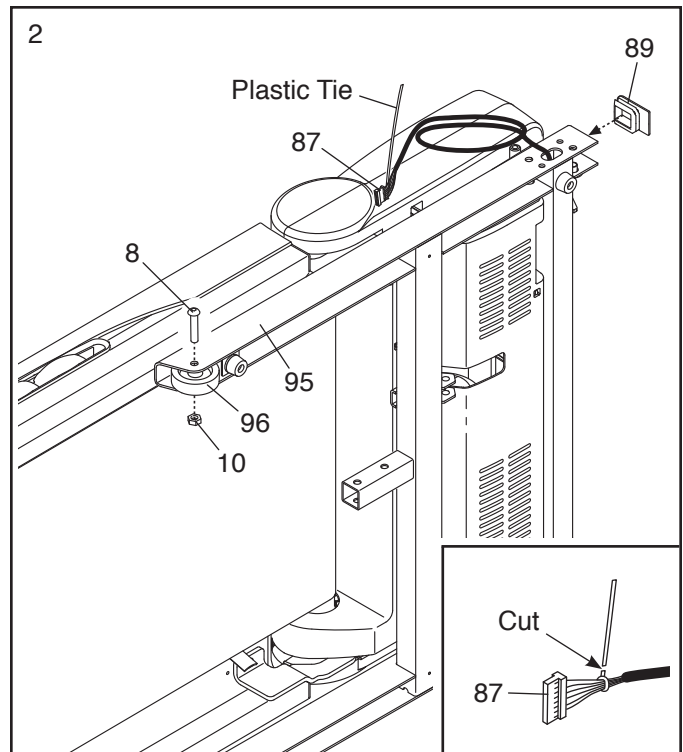

3. Identify the Right Upright (85). Hold the Right Upright near the Base (95) as shown.

**See the inset drawing.** Tie the wire tie in the Right Upright (85) securely around the end of the Upright Wire (87). Then, pull the other end of the wire tie until the Upright Wire is routed through the Right Upright.

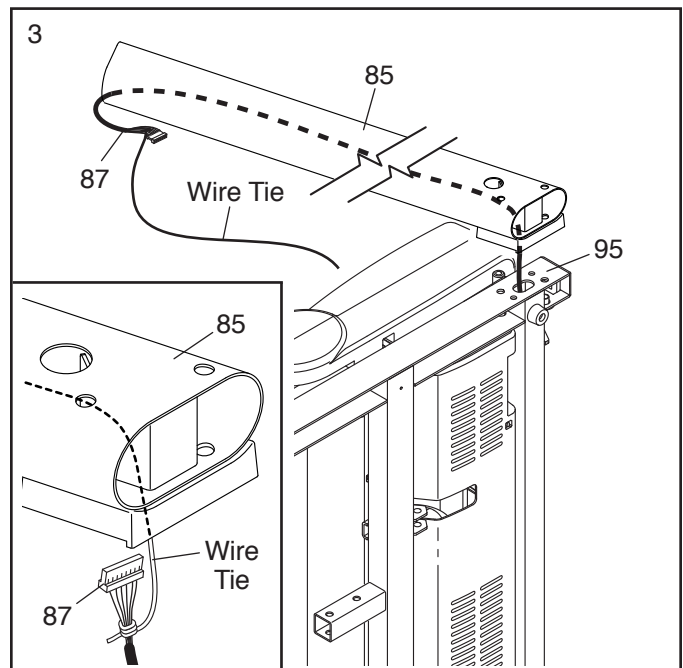



4. Hold the Right Upright (85) against the Base (95). **Be careful not to pinch the Upright Wire (87).** Insert two 3/8" x 4" Screws (7) with two 3/8" Star Washers (11) and a 3/8" x 1 1/2" Screw (14) with a 3/8" Star Washer (11) into the Right Upright.

Partially tighten the 3/8" x 4" Screws (7) until the heads of the Screws touch the Right Upright (85); **do not fully tighten the Screws yet.** Partially tighten the 3/8" x 1 1/2" Screw (14).

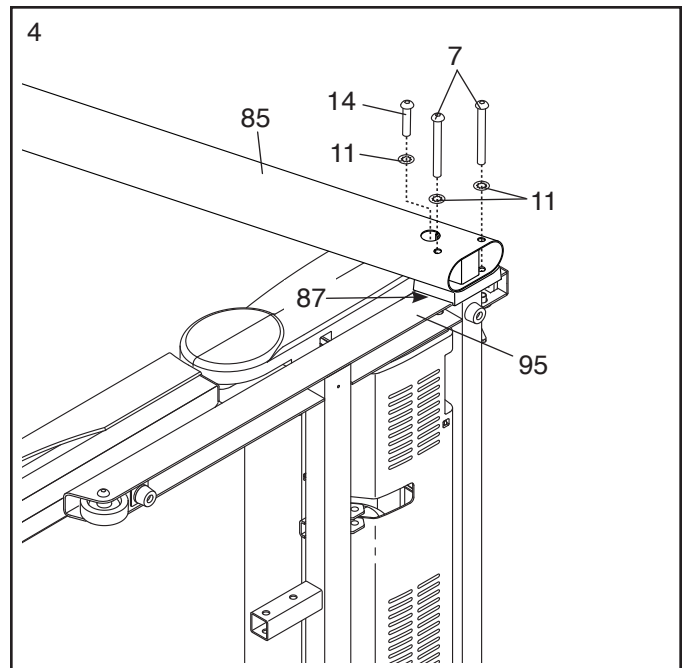

5. With the help of a second person, lift the treadmill so that the Base (95) is flat on the floor.

Attach a Wheel (96) to the Base (95) with a 3/8" x 2" Bolt (8) and a 3/8" Nut (10). **Do not over-tighten the Nut; the Wheel must turn freely.**

Press a Base Cap (89) into the Base (95).

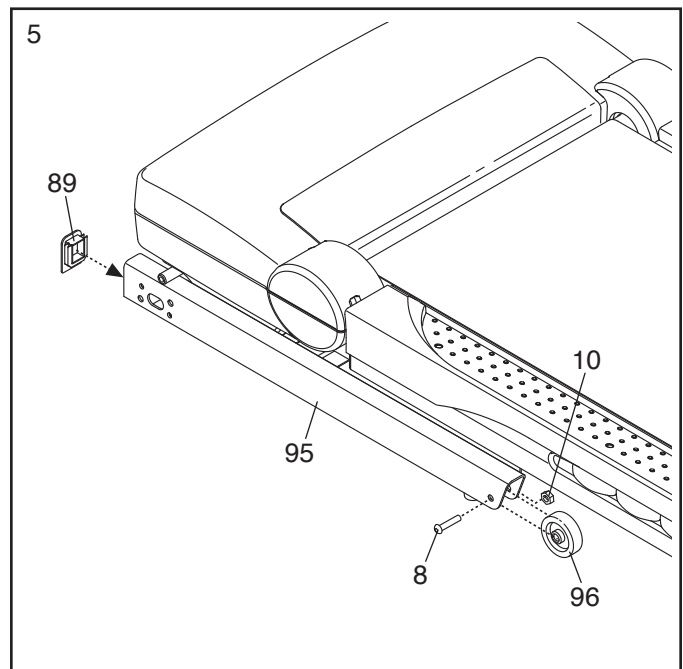

6. Hold the Left Upright (84) against the Base (95). Insert two 3/8" x 4" Screws (7) with two 3/8" Star Washers (11) and a 3/8" x 1 1/2" Screw (14) with a 3/8" Star Washer (11) into the Left Upright.

Partially tighten the 3/8" x 4" Screws (7) until the heads of the Screws touch the Left Upright (84); **do not fully tighten the Screws yet.** Partially tighten the 3/8" x 1 1/2" Screw (14).

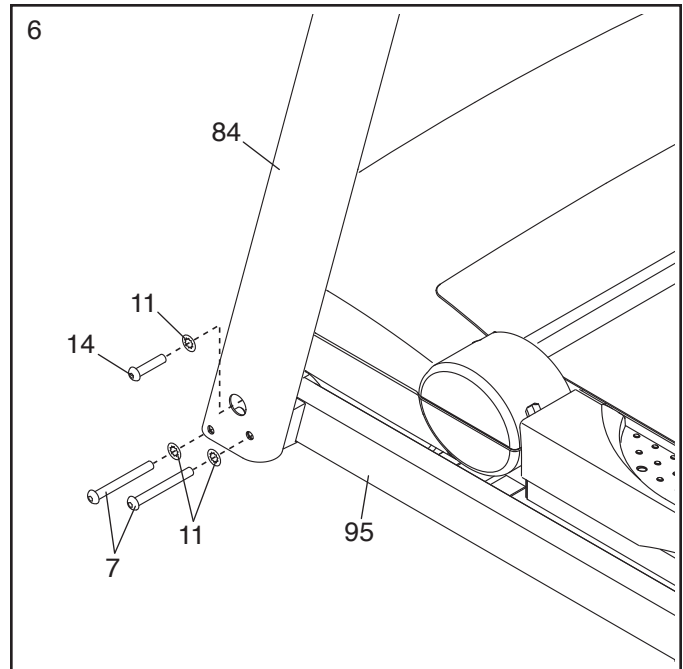

7. Identify the Right Base Cover (91) and the Left Base Cover (88). Slide the Right Base Cover onto the Right Upright (85) as shown. Slide the Left Base Cover onto the Left Upright (84).

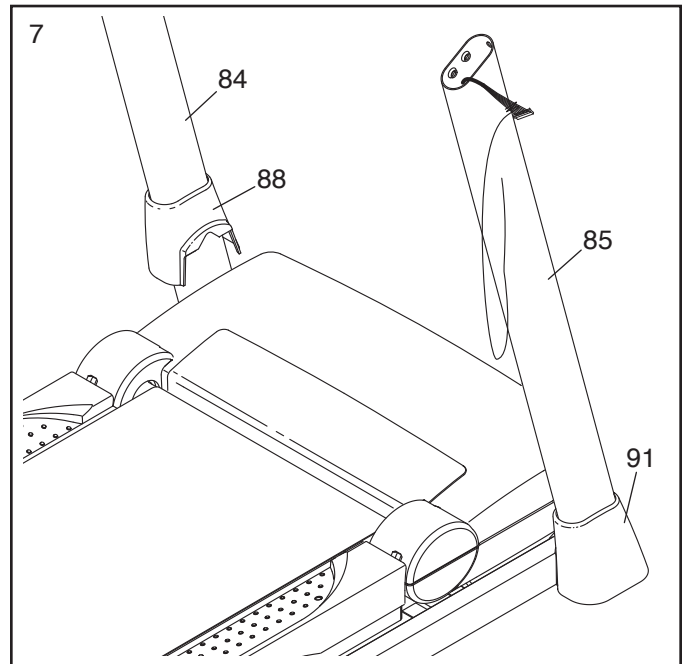

8. Identify the Right Upright Cover (86) and the Right Handrail (83). Slide the Right Upright Cover onto the Right Upright (85). Remove the tie from the bracket on the Right Handrail. If necessary, press the 5/16" Cage Nut (38) back into place.

Hold the Right Handrail (83) near the Right Upright (85). Insert the Upright Wire (87) through the bracket on the bottom of the Right Handrail. Pull the Upright Wire out of the end of the Right Handrail.

Attach the Right Handrail (83) to the Right Upright (85) with two 5/16" x 1" Screws (3) and a 5/16" x 1" Bolt (4) with a 5/16" Star Washer (13); **do not tighten the Screws and Bolt yet.**

**Attach the Left Upright Cover (not shown) and the Left Handrail (not shown) in the same way.** Note: There is no wire on the left side.

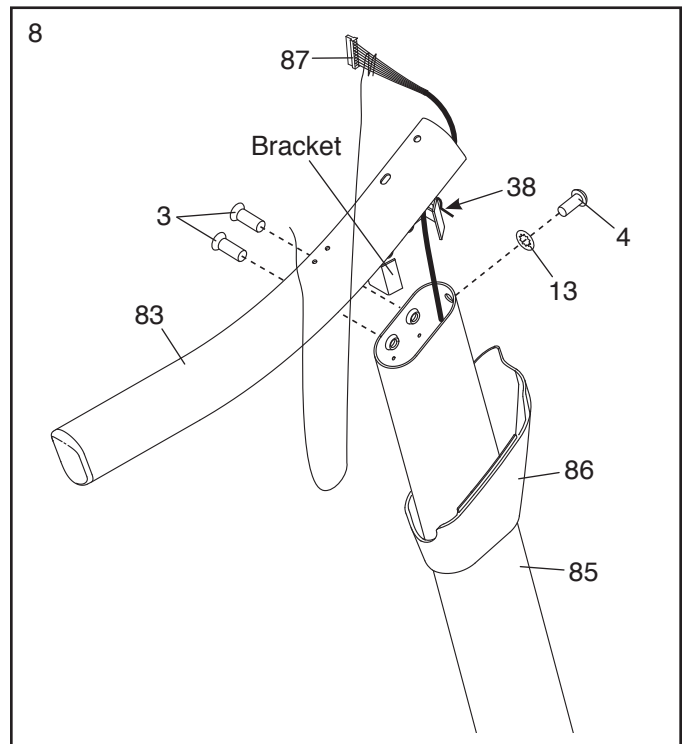

9. Set the console assembly face down on a soft surface to avoid scratching the console assembly.

Remove the Screws (A) attaching the Crossbar (104). Next, lift off the Crossbar. Discard the Screws.

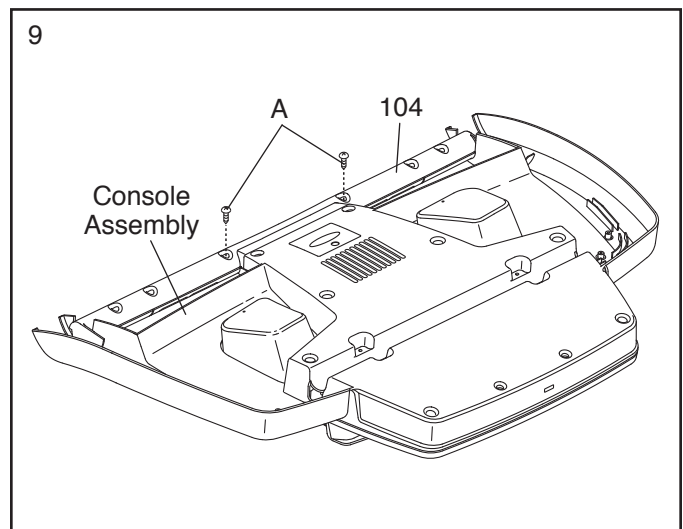

10. **IMPORTANT: To avoid damaging the Crossbar (104), do not use power tools and do not overtighten the #10 x 3/4" Screws (2).**

Orient the Crossbar (104) as shown. Attach the Crossbar to the Handrails (82, 83) with four #10 x 3/4" Screws (2) and four #10 Star Washers (12); **do not fully tighten the Screws yet.** **Note: The #10 Star Washers are slightly smaller than the 1/4" Star Washers (not shown).**

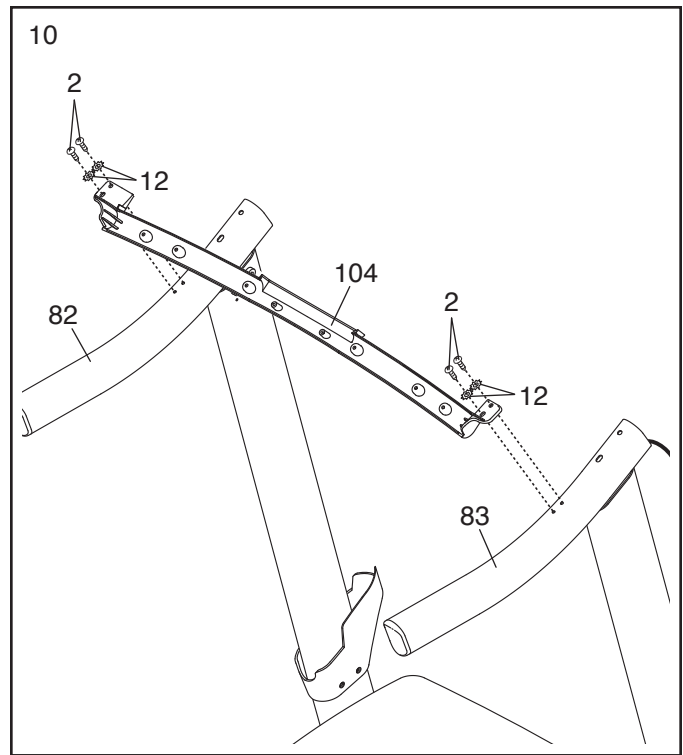

11. Remove and discard the four indicated screws (B) from the Console Frame (102).

Insert the Console Frame (102) into the Handrails (82, 83). Attach the Console Frame with four 1/4" x 1" Screws (9) and four 1/4" Star Washers (34); **do not tighten the Screws yet.** **Be careful not to pinch the Upright Wire (87).**

**Tighten the indicated #10 x 3/4" Screws (2) in each end of the Crossbar (104) first; do not overtighten the Screws.** Then, tighten the other #10 x 3/4" Screws (2) in each end of the Crossbar.

**Tighten the four 1/4" x 1" Screws (9).**

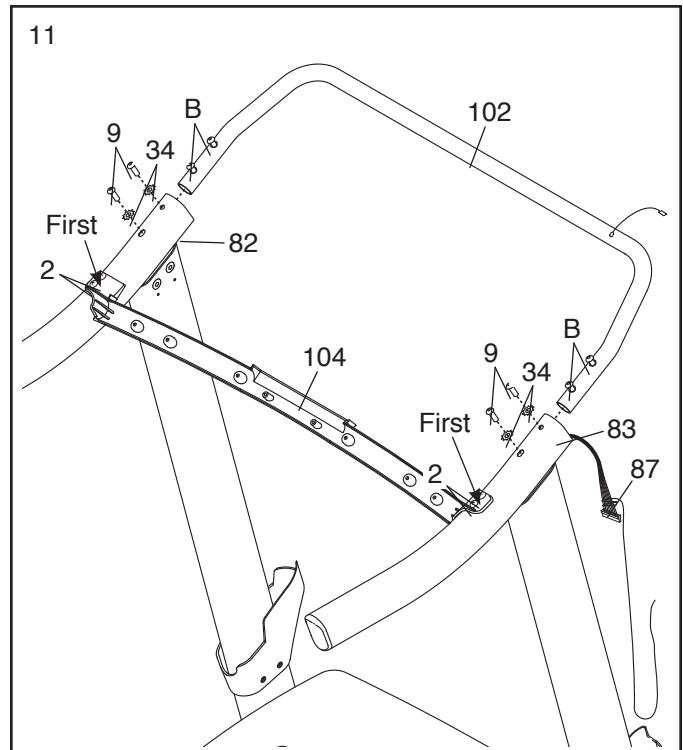

12. Firmly tighten the four 5/16" x 1" Screws (3) and the two 5/16" x 1" Bolts (4) (only one side is shown).

With the help of a second person, hold the console assembly near the Right Handrail (83) and the Left Handrail (not shown).

Connect the Upright Wire (87) to the console wire. **See the inset drawing. The connectors should slide together easily and snap into place.** If they do not, turn one connector and try again. **IF YOU DO NOT CONNECT THE CONNECTORS PROPERLY, THE CONSOLE MAY BECOME DAMAGED WHEN YOU TURN ON THE POWER.** Remove the wire tie from the Upright Wire.

Connect the ground wire from the console assembly to the Console Ground Wire (52). Insert the wires into the console assembly.

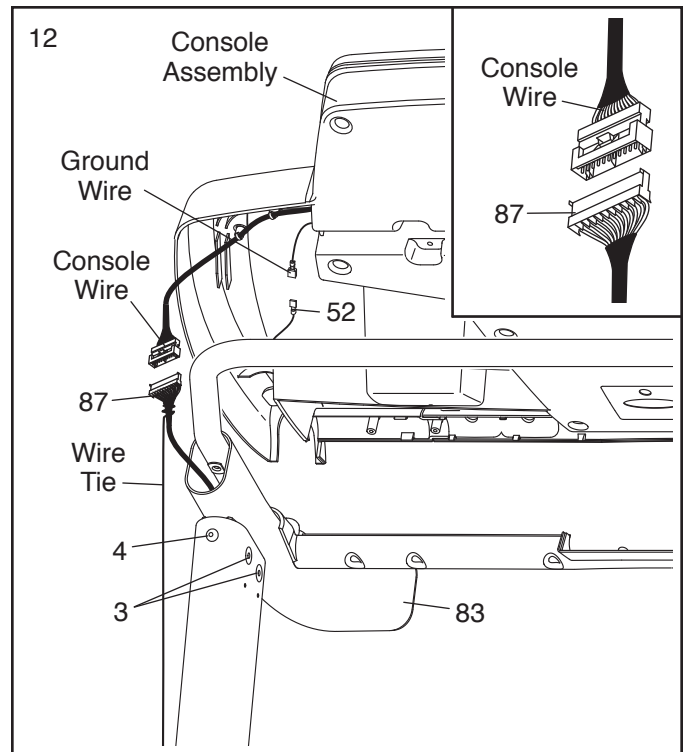

13. Set the console assembly on the Left and Right Handrails (82, 83). **Be careful not to pinch any wires.** Insert the excess Upright Wire (87) into the Right Handrail.

Attach the console assembly to the Crossbar (104) with six #8 x 3/4" Screws (1). **Start all six Screws, and then tighten them.**

Attach the two Console Clamps (105) to the console assembly with four #8 x 1" Screws (53).

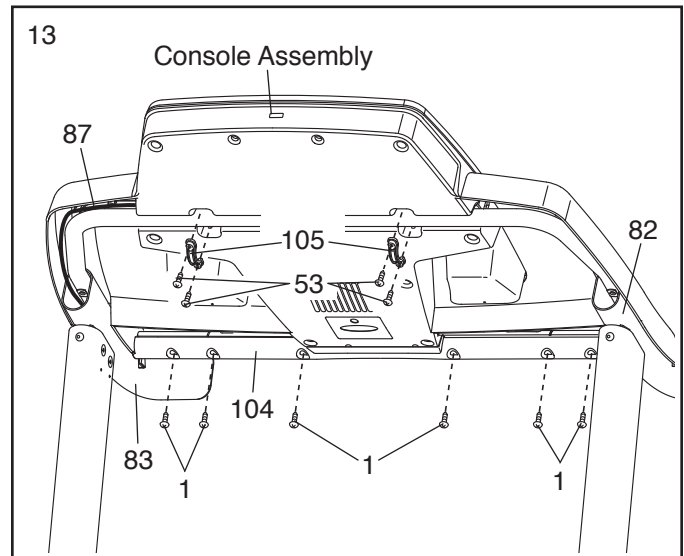

14. Hold the Right Upright Cover (86) against the console assembly. Align the holes in the Right Upright Cover with the holes in the Right Upright (85). Attach the Right Upright Cover with two #8 x 3/4" Screws (1).

Attach the Left Upright Cover (80) to the Left Upright (84) in the same way.

**See steps 4 and 6.** Tighten the four 3/8" x 4" Screws (7) and the two 3/8" x 1 1/2" Screws (14).

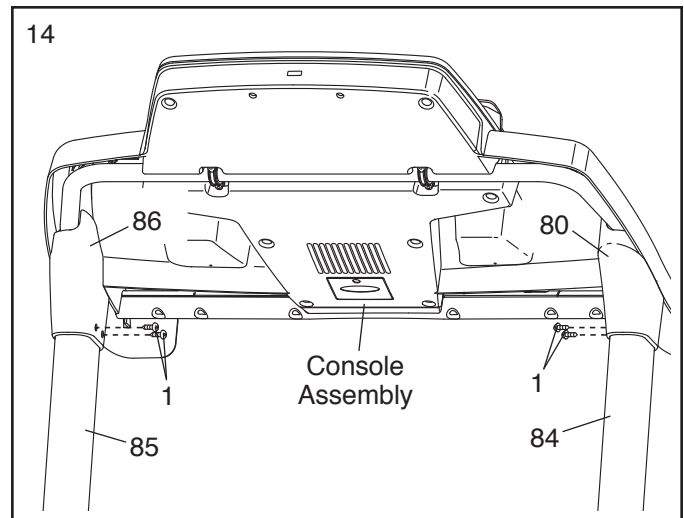

15. Raise the Frame (55) to the position shown. **Have a second person hold the Frame until this step is completed.**

Orient the Storage Latch (51) so that the large barrel and the latch knob are oriented as shown.

Attach the Latch Bracket (39) to the Base (95) with two 3/8" x 2" Bolts (8) and two 3/8" Nuts (10).

Attach the upper end of the Storage Latch (51) to the bracket on the Frame (55) with a 3/8" x 2" Bolt (8) and a 3/8" Nut (10). Note: It may be necessary to move the Frame back and forth to align the Storage Latch with the bracket.

Lower the Frame (55) (see HOW TO LOWER THE TREADMILL FOR USE on page 22).

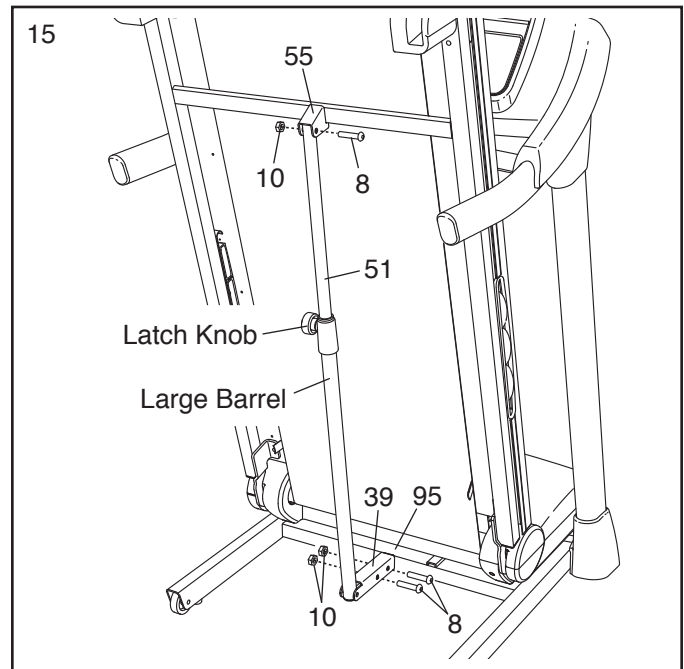

16. Insert the Left and Right Tray Inserts (61, 50) into the console assembly as shown.

17. **Make sure that all parts are properly tightened before you use the treadmill.** If there are sheets of plastic on the treadmill decals, remove the plastic. To protect the floor or carpet, place a mat under the treadmill. Note: Extra parts may be included. Keep the included hex keys in a secure place; one of the hex keys is used to adjust the walking belt (see pages 24 and 25).

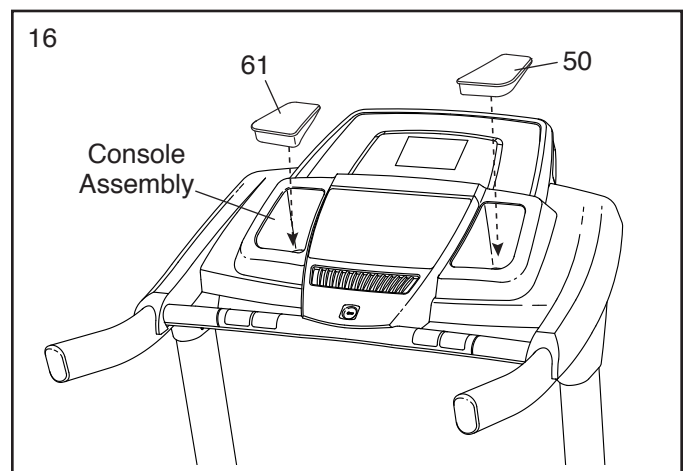

# OPERATION AND ADJUSTMENT

## HOW TO CONNECT THE POWER CORD

### Use a Surge Suppressor

Your treadmill, like other electronic equipment, can be damaged by sudden voltage changes in your home's power. Voltage surges, spikes, and noise interference can result from weather conditions or from other appliances being turned on or off. **To decrease the risk of damaging the treadmill, always use a surge suppressor with the treadmill. To purchase a surge suppressor, see precaution 13 on page 3.**

Use only a surge suppressor that is UL 1449 listed as a transient voltage surge suppressor (TVSS). The surge suppressor must have a UL suppressed voltage rating of 400 volts or less and a minimum surge dissipation of 450 joules. The surge suppressor must also be electrically rated for 120 volts AC and 15 amps. There must be a monitoring light on the surge suppressor to indicate whether it is functioning properly. **Failure to use a properly functioning surge suppressor could result in damage to the control system of the treadmill and serious injury to users.**

### Plug in the Power Cord

**The treadmill must be grounded.** If it should malfunction or break down, grounding provides a path of least resistance for electric current to reduce the risk of electric shock. The treadmill power cord has a plug with a grounding pin (see drawing 1 on this page).

**⚠ DANGER:** Improper connection of the power cord increases the risk of electric shock. Do not modify the plug—if it will not fit an outlet, have a proper outlet installed by a qualified electrician. If you are unsure whether the treadmill is properly grounded, contact a qualified electrician.

Plug the power cord into a surge suppressor, and plug the surge suppressor into an appropriate outlet that is properly installed and grounded in accordance with all local codes and ordinances. **The outlet must be on a**

nominal 120-volt circuit capable of carrying 15 or more amps. To avoid overloading the circuit, do not plug other electrical devices, except for low-power devices such as cell phone chargers, into the surge suppressor or into an outlet on the same circuit. **IMPORTANT: The treadmill is not compatible with GFCI-equipped outlets and may not be compatible with AFCI-equipped outlets.**

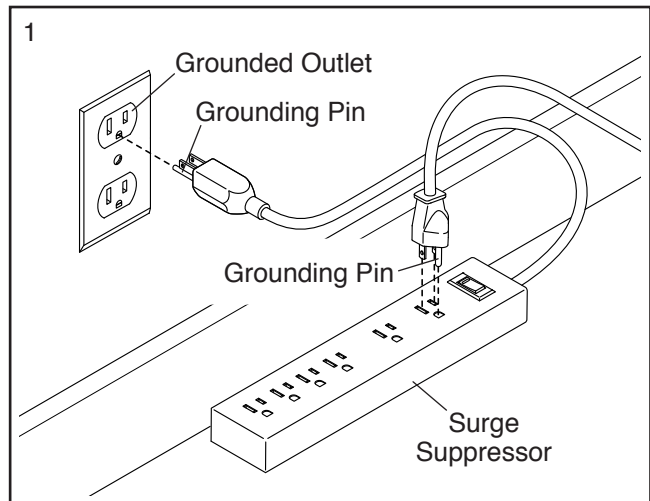

A temporary adapter may be used to connect the surge suppressor to a 2-pole receptacle if a properly grounded outlet is not available.

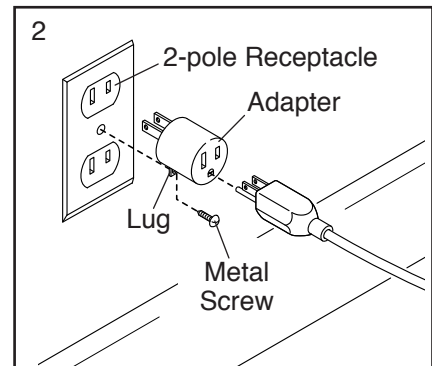

The lug or wire extending from the adapter must be connected with a metal screw to a permanent ground such as a properly grounded outlet box cover. **Some 2-pole receptacle outlet box covers are not grounded. Before using an adapter, contact a qualified electrician to determine whether the outlet box cover is grounded. The temporary adapter should be used only until a properly grounded outlet can be installed by a qualified electrician.**

## CONSOLE DIAGRAM

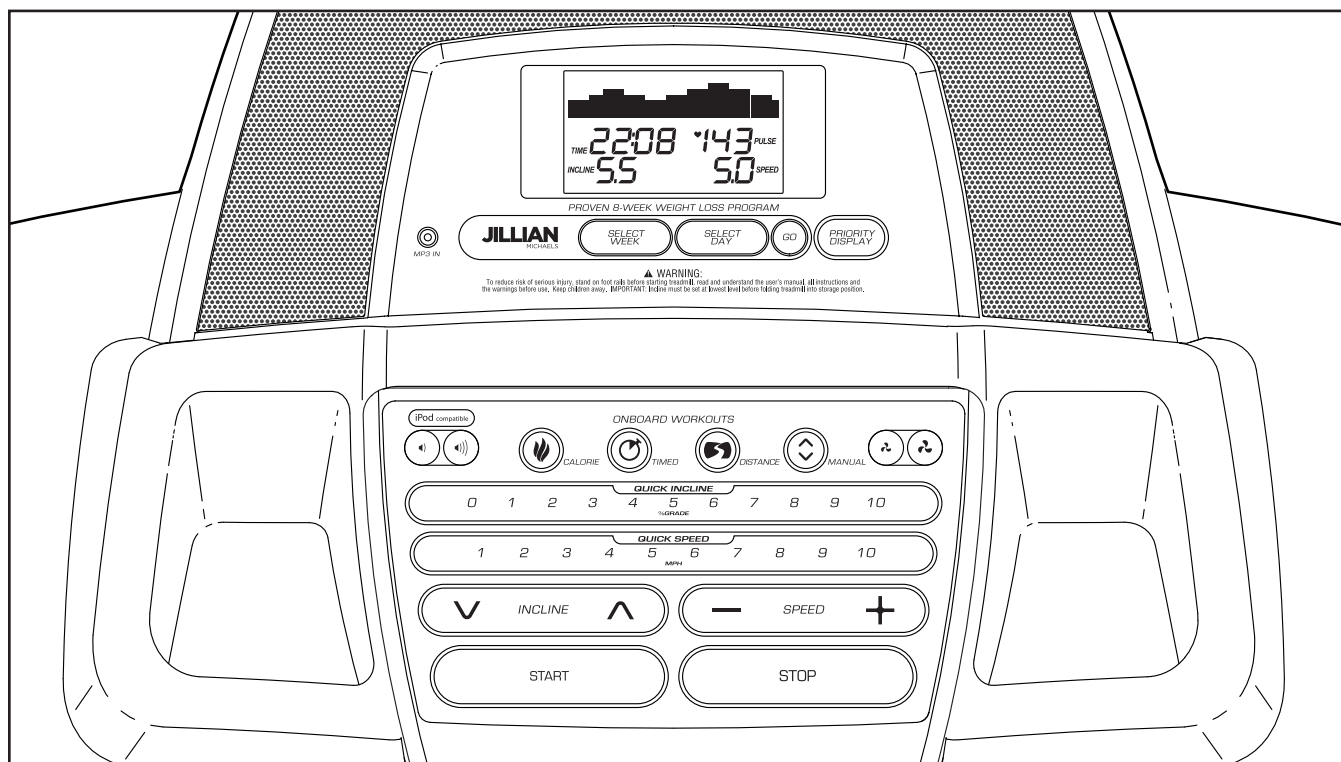

### FEATURES OF THE CONSOLE

The treadmill console offers an impressive array of features designed to make your workouts more effective and enjoyable. When you use the manual mode, you can change the speed and incline of the treadmill with the touch of a button. As you exercise, the console will display instant exercise feedback. You can even measure your heart rate using the handgrip heart rate monitor.

In addition, the console features sixteen onboard workouts—six calorie workouts, five timed workouts, and five distance workouts. Each workout automatically controls the speed and incline of the treadmill as it guides you through an effective exercise session.

Lose unwanted pounds with the progressive 8-week weight-loss program. Each workout in the program controls the speed and incline of the treadmill as it guides you through an effective workout designed to help you achieve the results you want.

You can even listen to your favorite workout music or audio books with the console's stereo sound system while you exercise.

**To turn on the power, see page 17. To use the manual mode, see page 17. To use an onboard workout, see page 19. To use an 8-week weight-loss workout, see page 20. To use the stereo sound system, see page 21. To use the information mode, see page 21.**

Note: The console can display speed and distance in either miles or kilometers. To find which unit of measurement is selected, see THE INFORMATION MODE on page 21. For simplicity, all instructions in this manual refer to miles.

**IMPORTANT: If there are sheets of plastic on the console, remove the plastic. To prevent damage to the walking platform, wear clean athletic shoes while using the treadmill. The first time you use the treadmill, observe the alignment of the walking belt, and center the walking belt if necessary (see page 25).**



## HOW TO TURN ON THE POWER

**IMPORTANT:** If the treadmill has been exposed to cold temperatures, allow it to warm to room temperature before turning on the power. If you do not do this, you may damage the console displays or other electrical components.

Plug in the power cord (see page 15). Next, locate the power switch on the treadmill frame near the power cord. Press the power switch into the reset position.

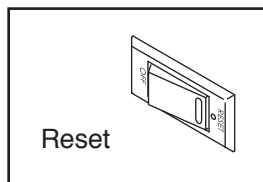

**IMPORTANT:** The console features a display demo mode, designed to be used if the treadmill is displayed in a store. If the displays light as soon as you plug in the power cord and press the power switch into the reset position, the demo mode is turned on. To turn off the demo mode, hold down the Stop button for a few seconds. If the displays remain lit, see THE INFORMATION MODE on page 21 to turn off the demo mode.

Next, stand on the foot rails of the treadmill. Find the clip attached to the key and slide the clip onto the waistband of your clothes. Then, insert the key into the console.

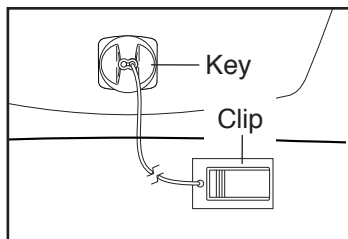

After a moment, the displays will light.

**IMPORTANT:** In an emergency, the key can be pulled from the console, causing the walking belt to slow to a stop. Test the clip by carefully taking a few steps backward; if the key is not pulled from the console, adjust the position of the clip.

## HOW TO USE THE MANUAL MODE

### 1. Insert the key into the console.

See HOW TO TURN ON THE POWER at the left.

### 2. Select the manual mode.

When the key is inserted, the manual mode will be selected. If you have selected a workout, press the Manual button on the console.

### 3. Start the walking belt.

To start the walking belt, press the Start button, the Speed increase button, or one of the Quick Speed buttons numbered 1 through 10.

If you press the Start button or the Speed increase button, the walking belt will begin to move at 1 mph. As you exercise, change the speed of the walking belt as desired by pressing the Speed increase and decrease buttons. Each time you press one of the buttons, the speed setting will change by 0.1 mph; if you hold down the button, the speed setting will change more quickly. Note: After you press the button, it may take a moment for the walking belt to reach the selected speed setting.

If you press one of the numbered Quick Speed buttons, the walking belt will gradually change speed until it reaches the selected speed setting.

To stop the walking belt, press the Stop button. The time will begin to flash in the display. To restart the walking belt, press the Start button or the Speed increase button.

### 4. Change the incline of the treadmill as desired.

To change the incline of the treadmill, press the Incline increase or decrease button or one of the numbered Quick Incline buttons. Each time you press one of the buttons, the treadmill will gradually adjust to the selected incline setting.

## 5. Follow your progress with the display.

When the manual mode is selected, the upper half of the display will show a

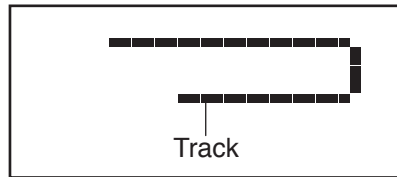

track that represents 1/4 mile (400 m). As you walk or run, indicators will appear in succession around the track until the entire track appears. The track will then disappear and the indicators will again begin to appear in succession.

The upper half of the display can also show the elapsed time, the distance you have walked or run, the speed of the walking belt, the approximate number of calories you have burned, your pace in minutes per mile, and the incline of the treadmill. Press the Priority Display button repeatedly until the desired workout information appears.

The lower left corner of the display will show the elapsed time, the distance that you have walked or run, and the incline level of the treadmill. Note: When an onboard workout is selected, the display will show the time remaining in the workout instead of the elapsed time.



The lower right corner of the display will show the approximate number of calories you have burned, the speed of the walking belt, and your pace in minutes per mile. The display will also show your heart rate when you use the handgrip heart rate monitor.



To reset the display, press the Stop button, remove the key, and then reinsert the key.

## 6. Measure your heart rate if desired.

Before using the handgrip heart rate monitor, remove the sheets of plastic from the metal contacts on the pulse bar. In addition, make sure that your hands are clean.

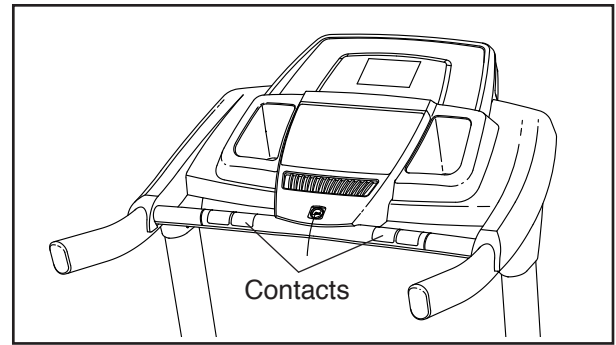

To measure your heart rate, **stand on the foot rails** and hold the pulse bar with your palms on the metal contacts for approximately ten seconds; **avoid moving your hands**. When your pulse is detected, a heart symbol in the calorie display will flash each time your heart beats, one or two dashes will appear, and then your heart rate will be shown. **For the most accurate heart rate reading, continue to hold the contacts for about 15 seconds.**

## 7. Turn on the fan if desired.

The fan features multiple speed settings. Press the fan increase or decrease button to select a fan speed or to turn off the fan. Note: If the fan is on when the walking belt is stopped, the fan will turn off automatically after a few minutes.

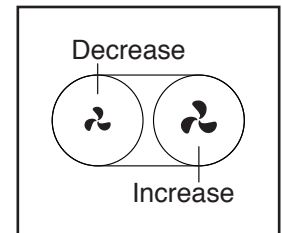

## 8. When you are finished exercising, remove the key from the console.

Step onto the foot rails, press the Stop button, and **adjust the incline of the treadmill to the lowest setting. The incline must be at the lowest setting or you may damage the treadmill when you fold it to the storage position.** Next, remove the key from the console and put it in a secure place.

When you are finished using the treadmill, press the power switch into the off position and unplug the power cord. **IMPORTANT: If you do not do this, the treadmill's electrical components may wear prematurely.**

## HOW TO USE AN ONBOARD WORKOUT

### 1. Insert the key into the console.

See HOW TO TURN ON THE POWER on page 17.

### 2. Select an onboard workout.

To select an onboard workout, press the Calorie button, the Timed button, or the Distance button repeatedly until the desired workout appears in the display.

When you select an onboard workout, the maximum speed setting and the maximum incline setting of the workout will flash in the display for a few seconds and a profile of the speed settings of the workout will scroll across the display. If you select a Calorie workout, the approximate number of calories you will burn will also appear in the display.

### 3. Start the workout.

Press the Start button or the Speed increase button to start the workout. A moment after you press the button, the treadmill will automatically adjust to the first speed and incline settings of the workout. Hold the handrails and begin walking.

Each workout is divided into one-minute segments. One speed setting and one incline setting are programmed for each segment. Note: The same speed setting and/or incline setting may be programmed for consecutive segments.

During the workout, the profile will show your progress. The flashing segment of

the profile represents the current segment of the workout. The height of the flashing segment indicates the speed setting for the current segment. At the end of each segment, a series of tones will sound and the next segment of the profile will begin to flash. If a new speed and/or incline setting is programmed for the next segment, the new speed and/or incline setting will appear in the displays for a few seconds and the treadmill will automatically adjust to the new speed and/or incline setting.



The workout will continue in this way until the last segment of the profile flashes in the display and the last segment ends. The walking belt will then slow to a stop.

**Note: The calorie goal is an estimate of the number of calories that you will burn during the workout. The actual number of calories that you burn will depend on various factors such as your weight. In addition, if you manually change the speed or incline of the treadmill during the workout, the number of calories you burn will be affected.**

If the speed or incline setting is too high or too low at any time during the workout, you can manually override the setting by pressing the Speed or Incline buttons; **however, when the next segment of the workout begins, the treadmill will automatically adjust to the speed and incline settings for the next segment.**

To stop the workout at any time, press the Stop button. The time will begin to flash in the display. To resume the workout, press the Start button or the Speed increase button. The walking belt will begin to move at 1 mph. When the next segment of the workout begins, the treadmill will automatically adjust to the speed and incline settings for the next segment.

### 4. Follow your progress with the display.

See step 5 on page 18. The lower left corner of the display will show the time remaining instead of the elapsed time.

### 5. Measure your heart rate if desired.

See step 6 on page 18.

### 6. Turn on the fan if desired.

See step 7 on page 18.

### 7. When you are finished exercising, remove the key from the console.

See step 8 on page 18.

## HOW TO USE AN 8-WEEK WEIGHT-LOSS WORKOUT

### 1. Insert the key into the console.

See HOW TO TURN ON THE POWER on page 17.

### 2. Select the desired week of the program.

To select the desired week of the program, press the Select Week button repeatedly until the number of the desired week appears in the upper left display.

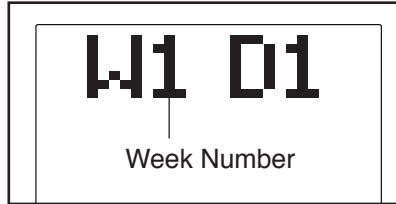

### 3. Select the desired day of the program.

There are three day workouts for each week of the program. To select the desired day of the program, press the Select Day button repeatedly until the number of the desired day appears in the upper right display.

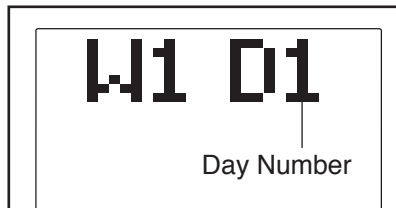

### 4. Start the workout.

Press the Go button, and then press the Start button to start the workout.

The workout will function in the same way as an onboard workout (see step 3 on page 19).

### 5. Follow your progress with the display.

See step 5 on page 18. The lower left corner of the display will show the time remaining instead of the elapsed time.

### 6. Measure your heart rate if desired.

See step 6 on page 18.

### 7. Turn on the fan if desired.

See step 7 on page 18.

### 8. When you are finished exercising, remove the key from the console.

See step 8 on page 18.

## HOW TO USE THE STEREO SOUND SYSTEM

To play music or audio books through the console's stereo speakers, you must connect your MP3 player, CD player, or other personal audio player to the console through the MP3 jack.

To use the MP3 jack, plug your audio wire into the MP3 jack. Then, plug your audio wire into a jack on your MP3 player, CD player, or other personal audio player.

**Make sure that your audio wire is fully inserted.**

Next, press the play button on your MP3 player, CD player, or other personal audio player. Adjust the volume on your personal audio player or press the volume increase and decrease buttons on the console.

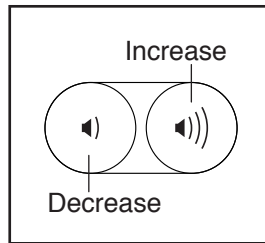

If you are using a personal CD player and the CD skips, set the CD player on the floor or another flat surface instead of on the console.

## THE INFORMATION MODE

The console features an information mode that keeps track of treadmill usage information. The information mode also allows you to select miles or kilometers as the unit of measurement and to turn on and turn off the display demo mode.

To select the information mode, hold down the Stop button, insert the key into the console, and then release the Stop button. When the information mode is selected, the following information will appear in the display:

- The number of hours that the treadmill has been operated.

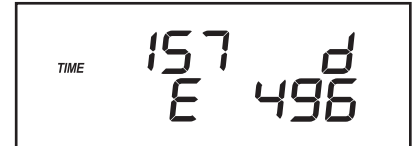

- The total number of miles or kilometers that the walking belt has moved.
- An "E" for English miles or an "M" for metric kilometers. To change the unit of measurement, press the Speed increase button.
- A "d" if the demo mode is turned on. The console features a display demo mode, designed to be used if the treadmill is displayed in a store. While the demo mode is turned on, the console will function normally when you plug in the power cord, press the power switch into the reset position, and insert the key into the console. However, when you remove the key, the displays will remain lit, although the buttons will not function. To turn on or turn off the demo mode, press the Speed decrease button.

To exit the information mode, remove the key from the console.

# HOW TO FOLD AND MOVE THE TREADMILL

## HOW TO FOLD THE TREADMILL

To avoid damaging the treadmill, adjust the incline to the lowest position before you fold the treadmill. Then, remove the key and unplug the power cord. **CAUTION:** You must be able to safely lift 45 lbs. (20 kg) to raise, lower, or move the treadmill.

1. Hold the metal frame firmly in the location shown by the arrow below. **CAUTION:** Do not hold the frame by the plastic foot rails. Bend your legs and keep your back straight.

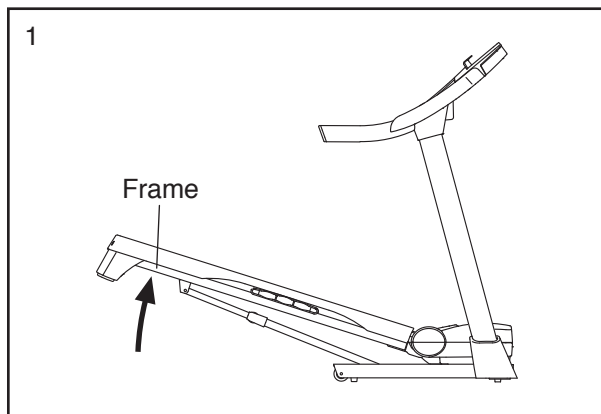

2. Raise the frame until the latch knob locks in the storage position. **CAUTION:** Make sure that the latch knob locks.

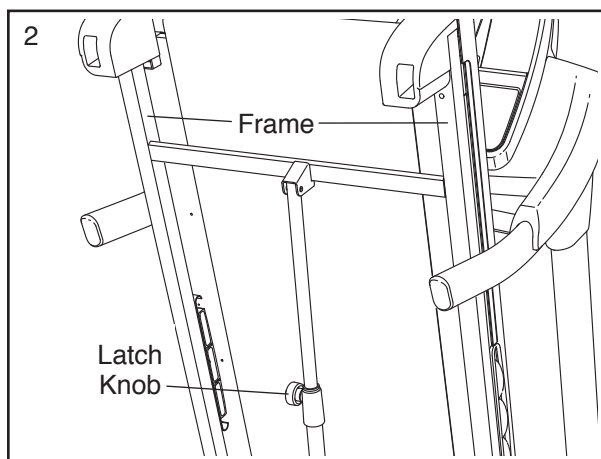

To protect the floor or carpet, place a mat under the treadmill. Keep the treadmill out of direct sunlight. Do not leave the treadmill in the storage position in temperatures above 85° F (30° C).

## HOW TO MOVE THE TREADMILL

Before moving the treadmill, fold it as described at the left. **CAUTION:** Make sure that the latch knob is locked in the storage position. Moving the treadmill may require two people.

1. Hold the frame and one of the handrails, and place one foot against a wheel.

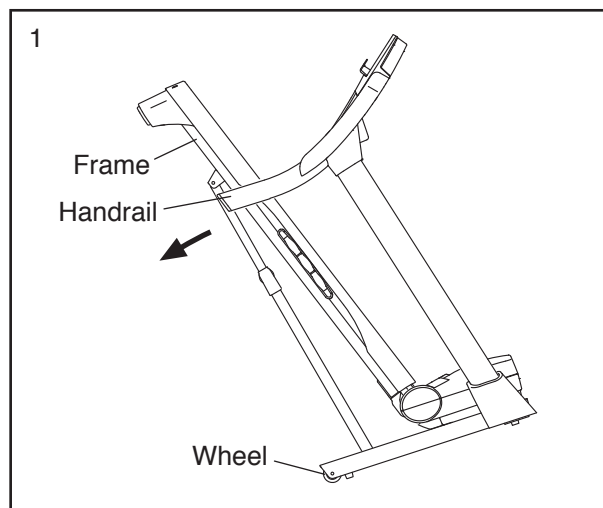

2. Pull back on the handrail until the treadmill will roll on the wheels, and carefully move it to the desired location. **CAUTION:** Do not move the treadmill without tipping it back, do not pull on the frame, and do not move the treadmill over an uneven surface.
3. Place one foot against a wheel, and carefully lower the treadmill.

## HOW TO LOWER THE TREADMILL FOR USE

1. **See drawing 2.** Hold the upper end of the treadmill frame with your right hand. Pull the latch knob to the left. **IMPORTANT:** Do not turn the latch knob. If necessary, push the frame forward slightly. Pivot the frame downward a few inches, and release the latch knob.
2. **See drawing 1 at the left.** Hold the metal frame firmly with both hands, and lower it to the floor. **CAUTION:** Do not hold the frame by the plastic foot rails, and do not drop the frame. Bend your legs and keep your back straight.

# TROUBLESHOOTING

Most treadmill problems can be solved by following the simple steps below. Find the symptom that applies, and follow the steps listed. If further assistance is needed, see the front cover of this manual.

## SYMPTOM: The power does not turn on

- Make sure that the power cord is plugged into a surge suppressor, and that the surge suppressor is plugged into a properly grounded outlet (see page 15). Use only a surge suppressor that meets all of the specifications described on page 15.  
**IMPORTANT: The treadmill is not compatible with GFCI-equipped outlets and may not be compatible with AFCI-equipped outlets.**
- After the power cord has been plugged in, make sure that the key is inserted into the console.
- Check the power switch located on the treadmill frame near the power cord. If the switch protrudes as shown, the switch has tripped. To reset the power switch, wait for five minutes and then press the switch back in.

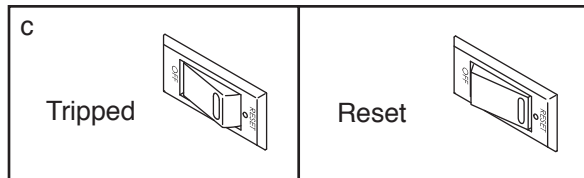

## SYMPTOM: The power turns off during use

- Check the power switch (see the drawing above). If the switch has tripped, wait for five minutes and then press the switch back in.
- Make sure that the power cord is plugged in. If the power cord is plugged in, unplug it, wait for five minutes, and then plug it back in.
- Remove the key from the console, and then reinsert it.
- If the treadmill still will not run, please see the front cover of this manual.

## SYMPTOM: The console displays remain lit when you remove the key from the console

- The console features a display demo mode, designed to be used if the treadmill is displayed in a store. If the displays remain lit when you remove the key, the demo mode is turned on. To turn off the demo mode, hold down the Stop button for a few seconds. If the displays are still lit, see THE INFORMATION MODE on page 21 to turn off the demo mode.

## SYMPTOM: The displays of the console do not function properly

- Remove the key from the console and **UNPLUG THE POWER CORD**. With the help of a second person, carefully tip down the Uprights (84, 85). There may be three #8 x 2" Screws (16) in the bottom of the Belly Pan (75). If there are, remove them. Note: A Phillips screwdriver with a shaft at least 5 in. (13 cm) long is required.

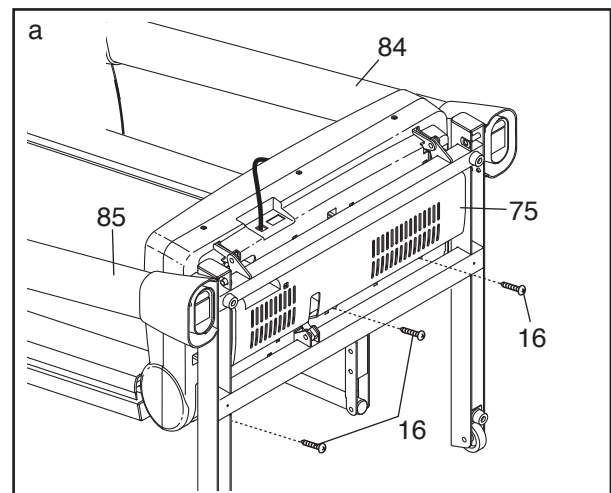

Then, raise the Uprights (84, 85).

Remove the three #8 x 3/4" Screws (1) and carefully pivot the Motor Hood (62) off.

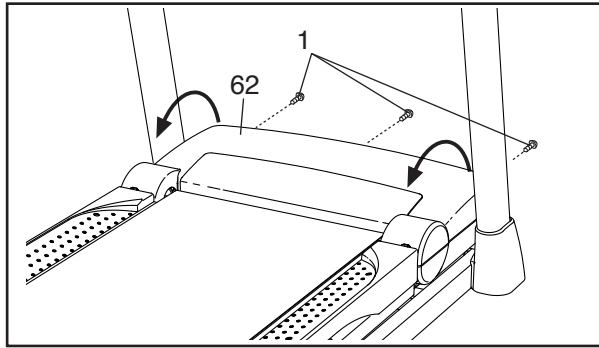

Locate the Reed Switch (73) and the Magnet (47) on the left side of the Pulley (48). Turn the Pulley until the Magnet is aligned with the Reed Switch. **Make sure that the gap between the Magnet and the Reed Switch is about 1/8 in. (3 mm).** If necessary, loosen the #8 x 3/4" Truss Head Screw (18), move the Reed Switch slightly, and then retighten the Screw. Reattach the Motor Hood (not shown) with the #8 x 3/4" Screws (not shown). Reattach the #8 x 2" Screws (not shown) if necessary. Run the treadmill for a few minutes to check for a correct speed reading.

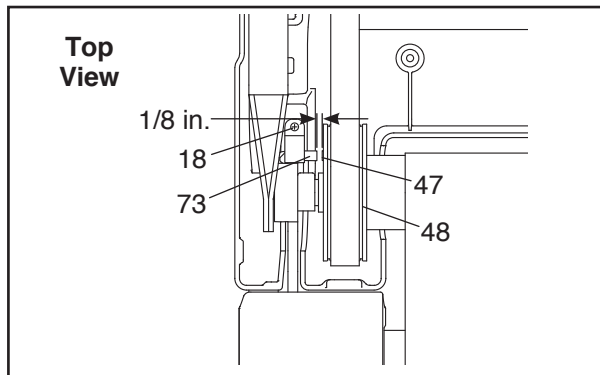

**SYMPTOM: The incline of the treadmill does not change correctly**

- a. Hold down the Stop button and the Speed increase button, insert the key into the console, and then release both buttons. Next, press the Stop button, and then press the Incline increase or decrease button. The treadmill will automatically rise to the maximum incline level and then return to the minimum level. This will calibrate the incline system.

If the incline system does not begin calibrating, press the Stop button, and then press the Incline increase or decrease button again. When the incline system is calibrated, remove the key from the console.

**SYMPTOM: The walking belt slows when walked on**

- a. Use only a surge suppressor that meets all of the specifications described on page 15.
- b. If the walking belt is overtightened, treadmill performance may decrease and the walking belt may become damaged. Remove the key and **UNPLUG THE POWER CORD**. Using the hex key, turn both idler roller screws counterclockwise, 1/4 of a turn. When the walking belt is properly tightened, you should be able to lift each edge of the walking belt 2 to 3 in. (5 to 7 cm) off the walking platform. Be careful to keep the walking belt centered. Then, plug in the power cord, insert the key, and run the treadmill for a few minutes. Repeat until the walking belt is properly tightened.

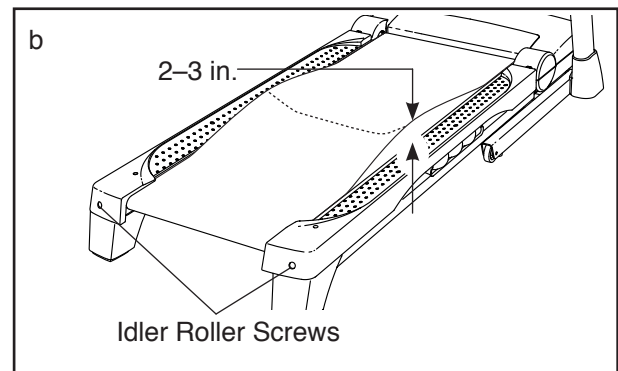

- c. Your treadmill features a walking belt coated with high-performance lubricant. **IMPORTANT: Never apply silicone spray or other substances to the walking belt or the walking platform unless instructed to do so by an authorized service representative. Such substances may deteriorate the walking belt and cause excessive wear.** If you suspect that the walking belt needs more lubricant, see the front cover of this manual.
- d. If the walking belt still slows when walked on, see the front cover of this manual.



**SYMPTOM: The walking belt is off-center or slips when walked on**

- a. **If the walking belt is off-center**, first remove the key and **UNPLUG THE POWER CORD**. **If the walking belt has shifted to the left**, use the hex key to turn the left idler roller screw clockwise 1/2 of a turn; **if the walking belt has shifted to the right**, turn the left idler roller screw counterclockwise 1/2 of a turn. Be careful not to overtighten the walking belt. Then, plug in the power cord, insert the key, and run the treadmill for a few minutes. Repeat until the walking belt is centered.

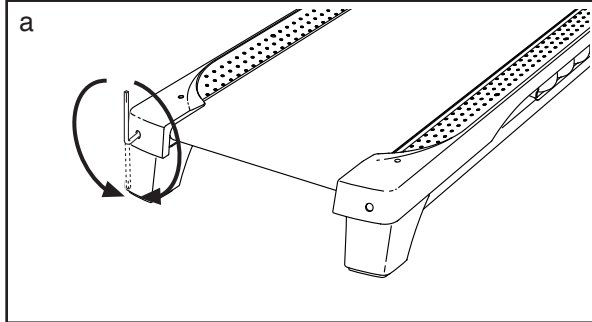

- b. **If the walking belt slips when walked on**, first remove the key and **UNPLUG THE POWER CORD**. Using the hex key, turn both idler roller screws clockwise, 1/4 of a turn. When the walking belt is correctly tightened, you should be able to lift each edge of the walking belt 2 to 3 in. (5 to 7 cm) off the walking platform. Be careful to keep the walking belt centered. Then, plug in the power cord, insert the key, and carefully walk on the treadmill for a few minutes. Repeat until the walking belt is properly tightened.

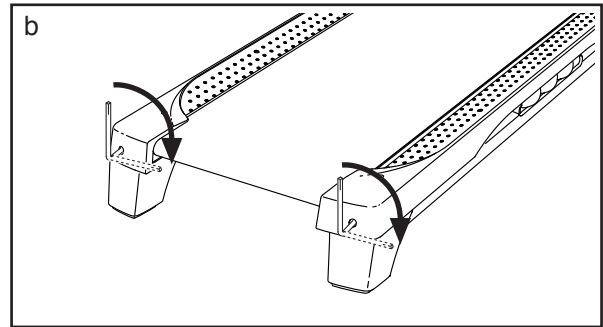

# EXERCISE GUIDELINES

**⚠️ WARNING:** Before beginning this or any exercise program, consult your physician. This is especially important for persons over age 35 or persons with pre-existing health problems.

The heart rate monitor is not a medical device. Various factors may affect the accuracy of heart rate readings. The heart rate monitor is intended only as an exercise aid in determining heart rate trends in general.

These guidelines will help you to plan your exercise program. For detailed exercise information, obtain a reputable book or consult your physician. Remember, proper nutrition and adequate rest are essential for successful results.

## EXERCISE INTENSITY

Whether your goal is to burn fat or to strengthen your cardiovascular system, exercising at the proper intensity is the key to achieving results. You can use your heart rate as a guide to find the proper intensity level. The chart below shows recommended heart rates for fat burning and aerobic exercise.

165	155	145	140	130	125	115	❤️
145	138	130	125	118	110	103	❤️
125	120	115	110	105	95	90	❤️
<hr/>							
20	30	40	50	60	70	80	

To find the proper intensity level, find your age at the bottom of the chart (ages are rounded off to the nearest ten years). The three numbers listed above your age define your “training zone.” The lowest number is the heart rate for fat burning, the middle number is the heart rate for maximum fat burning, and the highest number is the heart rate for aerobic exercise.

**Burning Fat**—To burn fat effectively, you must exercise at a low intensity level for a sustained period of time. During the first few minutes of exercise, your body uses carbohydrate calories for energy. Only after the first few minutes of exercise does your body begin to use stored fat calories for energy. If your goal is to burn fat, adjust the intensity of your exercise until your heart rate is near the lowest number in your training zone. For maximum fat burning, exercise with your heart rate near the middle number in your training zone.

**Aerobic Exercise**—If your goal is to strengthen your cardiovascular system, you must perform aerobic exercise, which is activity that requires large amounts of oxygen for prolonged periods of time. For aerobic exercise, adjust the intensity of your exercise until your heart rate is near the highest number in your training zone.

## WORKOUT GUIDELINES

**Warming Up**—Start with 5 to 10 minutes of stretching and light exercise. A warm-up increases your body temperature, heart rate, and circulation in preparation for exercise.

**Training Zone Exercise**—Exercise for 20 to 30 minutes with your heart rate in your training zone. (During the first few weeks of your exercise program, do not keep your heart rate in your training zone for longer than 20 minutes.) Breathe regularly and deeply as you exercise; never hold your breath.

**Cooling Down**—Finish with 5 to 10 minutes of stretching. Stretching increases the flexibility of your muscles and helps to prevent post-exercise problems.

## EXERCISE FREQUENCY

To maintain or improve your condition, complete three workouts each week, with at least one day of rest between workouts. After a few months of regular exercise, you may complete up to five workouts each week, if desired. Remember, the key to success is to make exercise a regular and enjoyable part of your everyday life.

# PART LIST

Model No. PFTL49612.1 R0712A

Key No.	Qty.	Description	Key No.	Qty.	Description
1	31	#8 x 3/4" Screw	54	1	Right Foot Rail
2	4	#10 x 3/4" Screw	55	1	Frame
3	4	5/16" x 1" Screw	56	2	Roller Bracket
4	2	5/16" x 1" Bolt	57	1	Roller Ground Wire
5	4	#8 x 1" Tek Screw	58	1	Right Rear Foot
6	1	Console Base	59	1	Left Rear Foot
7	4	3/8" x 4" Screw	60	1	Idler Roller
8	6	3/8" x 2" Bolt	61	1	Left Tray Insert
9	4	1/4" x 1" Screw	62	1	Motor Hood
10	6	3/8" Nut	63	1	Hood Accent
11	6	3/8" Star Washer	64	1	Lift Frame
12	4	#10 Star Washer	65	1	Lift Frame Ground Wire
13	2	5/16" Star Washer	66	1	Drive Motor Belt
14	2	3/8" x 1 1/2" Screw	67	1	Drive Motor
15	5	#8 x 3/4" Tek Screw	68	1	Controller Ground Wire
16	3	#8 x 2" Screw	69	1	Power Cord
17	4	#8 x 1/2" Pan Head Screw	70	1	Grommet
18	11	#8 x 3/4" Truss Head Screw	71	1	Power Switch
19	2	#8 x 1 1/2" Screw	72	1	Controller
20	2	5/16" x 1 1/2" Bolt	73	1	Reed Switch
21	2	5/16" x 3 5/8" Bolt	74	1	Reed Switch Clamp
22	2	3/8" x 1" Screw	75	1	Belly Pan
23	1	1/4" x 1" Screw	76	3	Wire Tie
24	2	Idler Roller Screw	77	8	8" Tie
25	1	3/8" x 1 3/4" Bolt	78	2	15" Tie
26	1	3/8" x 1 1/2" Bolt	79	4	Releasable Tie
27	2	3/8" x 3/4" Bolt	80	1	Left Upright Cover
28	7	#8 x 1/2" Bright Screw	81	2	Handrail Cap
29	1	#8 x 1/2" Ground Screw	82	1	Left Handrail
30	8	#12 x 1" Screw	83	1	Right Handrail
31	2	1/4" Motor Screw	84	1	Left Upright
32	4	#8 Belt Guide Screw	85	1	Right Upright
33	2	1/4" Roller Star Washer	86	1	Right Upright Cover
34	5	1/4" Star Washer	87	1	Upright Wire
35	4	3/8" Jam Nut	88	1	Left Base Cover
36	4	5/16" Flange Nut	89	2	Base Cap
37	3	Hood Clip	90	4	Base Foot
38	2	5/16" Cage Nut	91	1	Right Base Cover
39	1	Latch Bracket	92	2	Caution Decal
40	1	Left Foot Rail	93	1	Access Door
41	1	Latch Warning Decal	94	2	Base Foot Spacer
42	2	Platform Cushion	95	1	Base
43	2	Belt Guide	96	2	Wheel
44	1	Walking Platform	97	1	Incline Motor
45	2	Frame Cap	98	1	Incline Motor Spacer
46	2	Frame Spacer	99	1	Key/Clip
47	1	Magnet	100	2	Cable Tie
48	1	Front Roller/Pulley	101	1	Console
49	1	Walking Belt	102	1	Console Frame
50	1	Right Tray Insert	103	1	Tray
51	1	Storage Latch	104	1	Crossbar
52	1	Console Ground Wire	105	2	Console Clamp
53	4	#8 x 1" Screw	*	-	User's Manual

Note: Specifications are subject to change without notice. For information about ordering replacement parts, see the back cover of this manual. \*These parts are not illustrated.

# EXPLODED DRAWING A

Model No. PFTL49612.1 R0712A

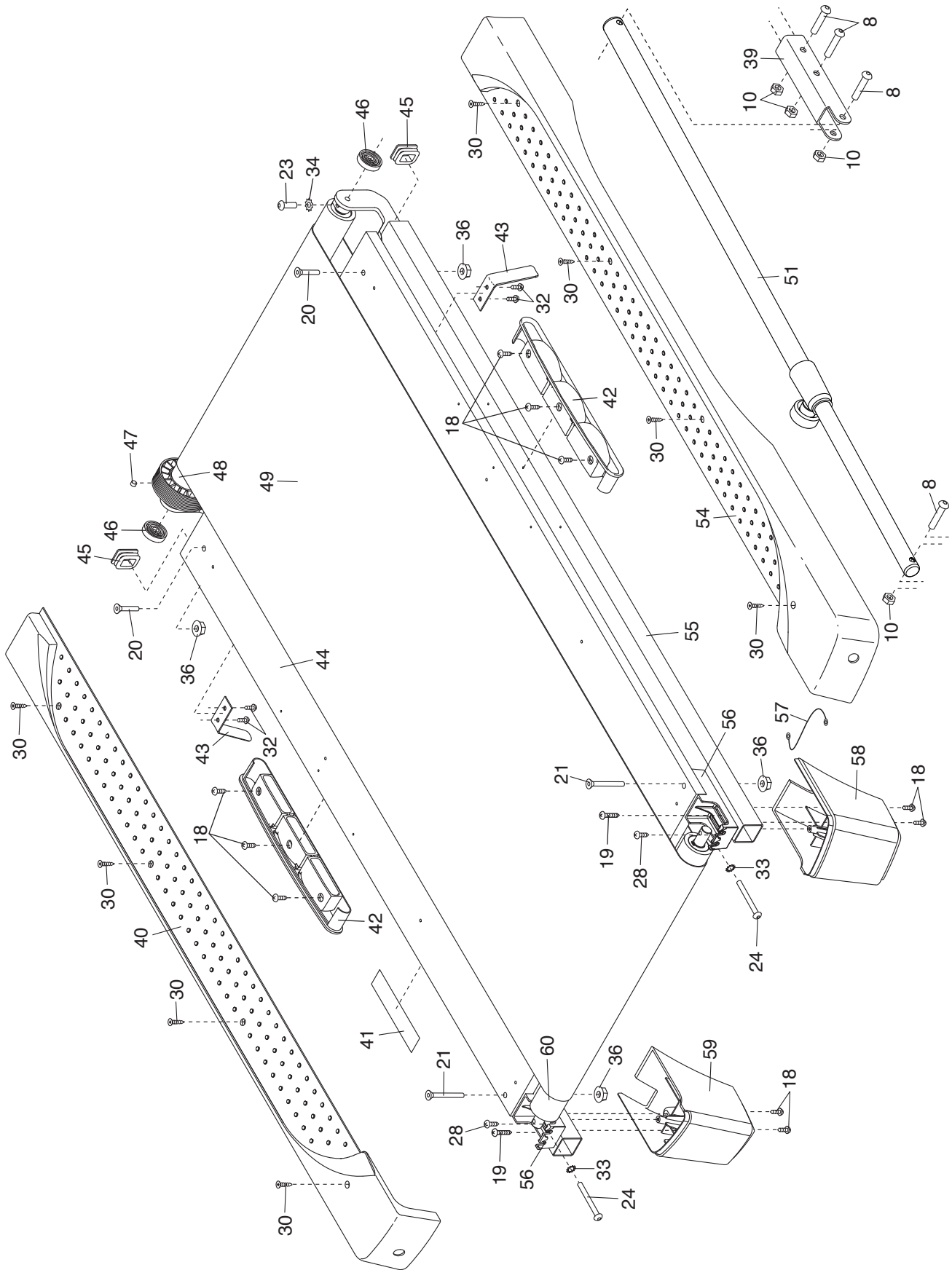

# EXPLODED DRAWING B

Model No. PFTL49612.1 R0712A

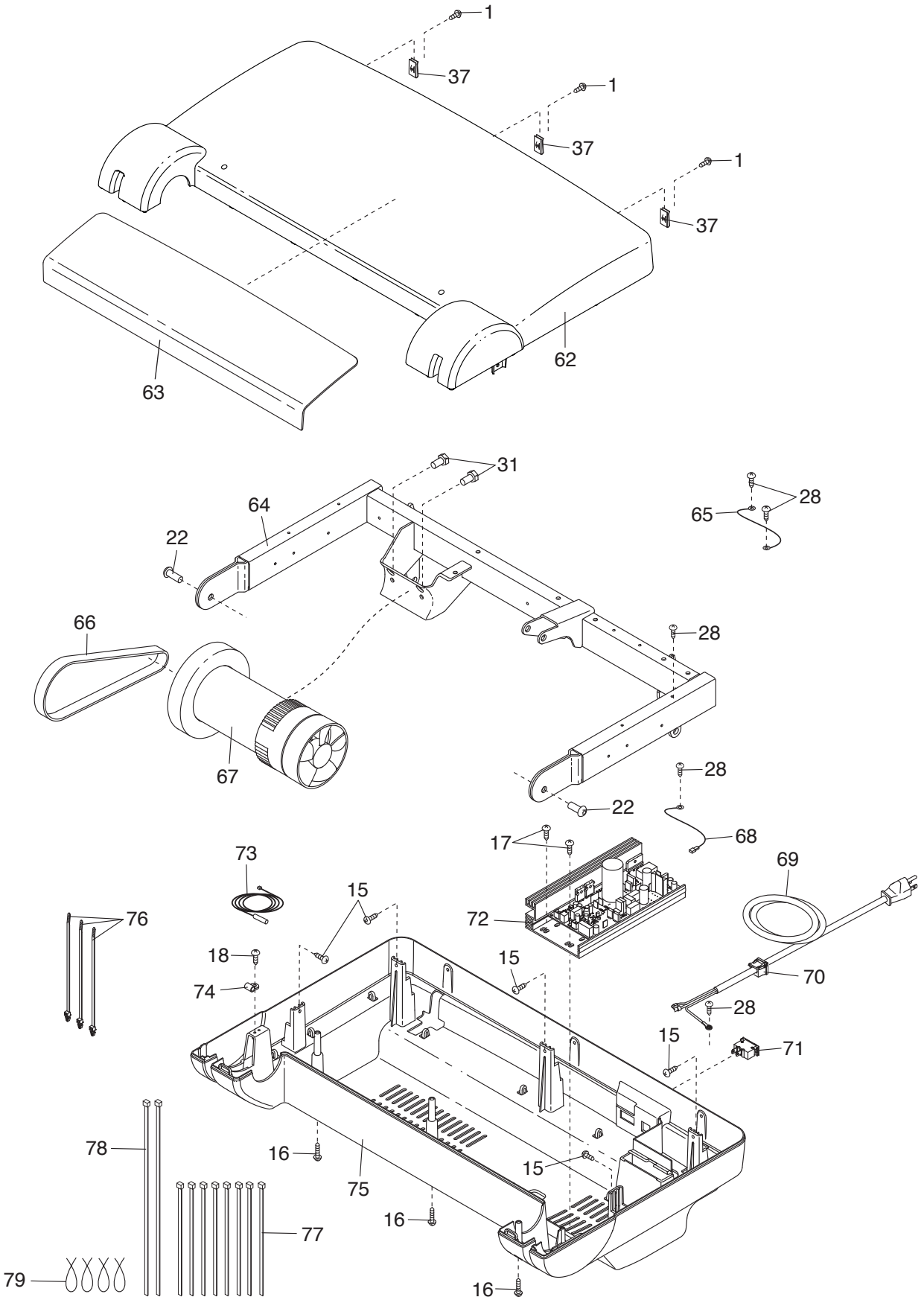

# EXPLODED DRAWING C

Model No. PFTL49612.1 R0712A

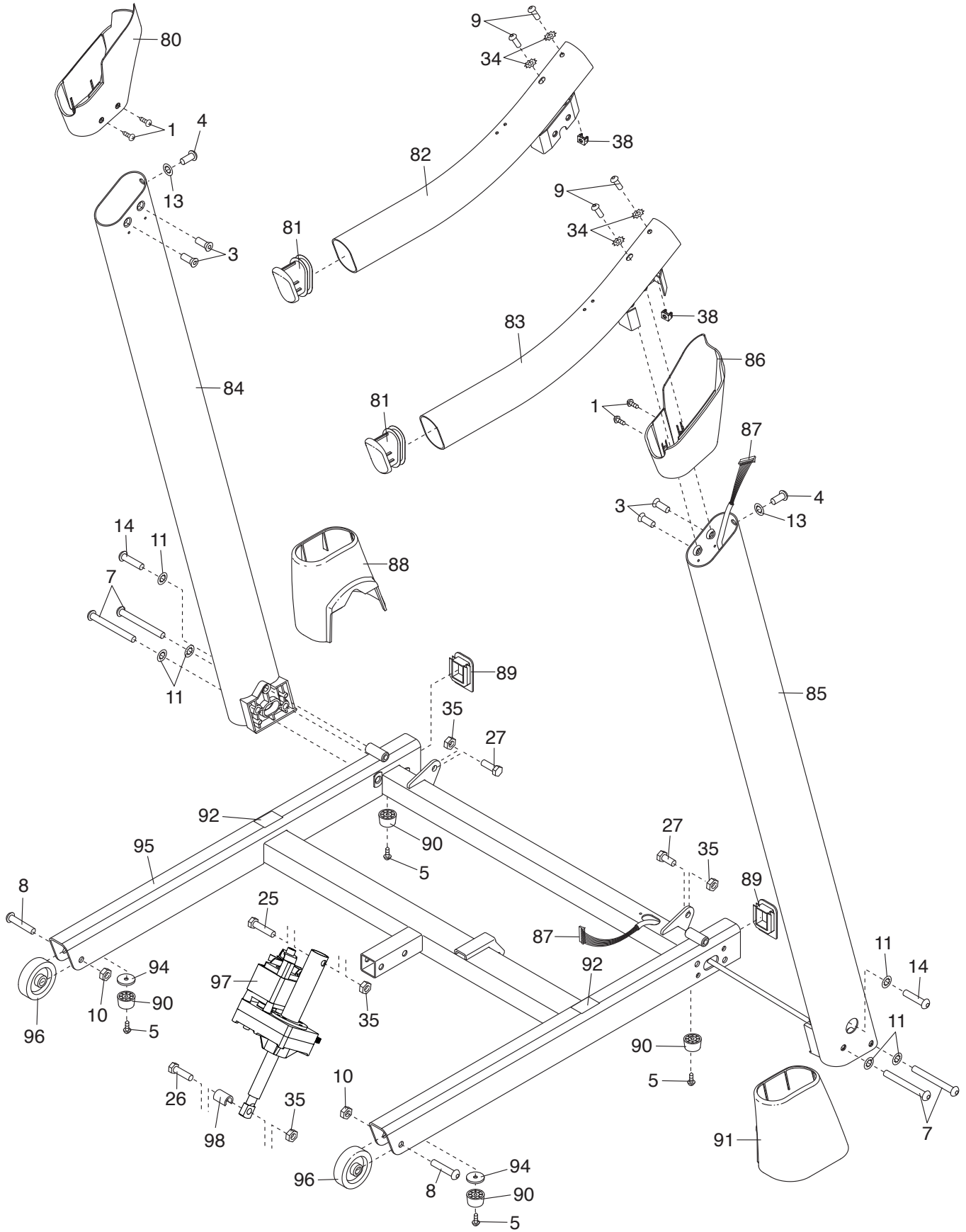

# EXPLODED DRAWING D

Model No. PFTL49612.1 R0712A

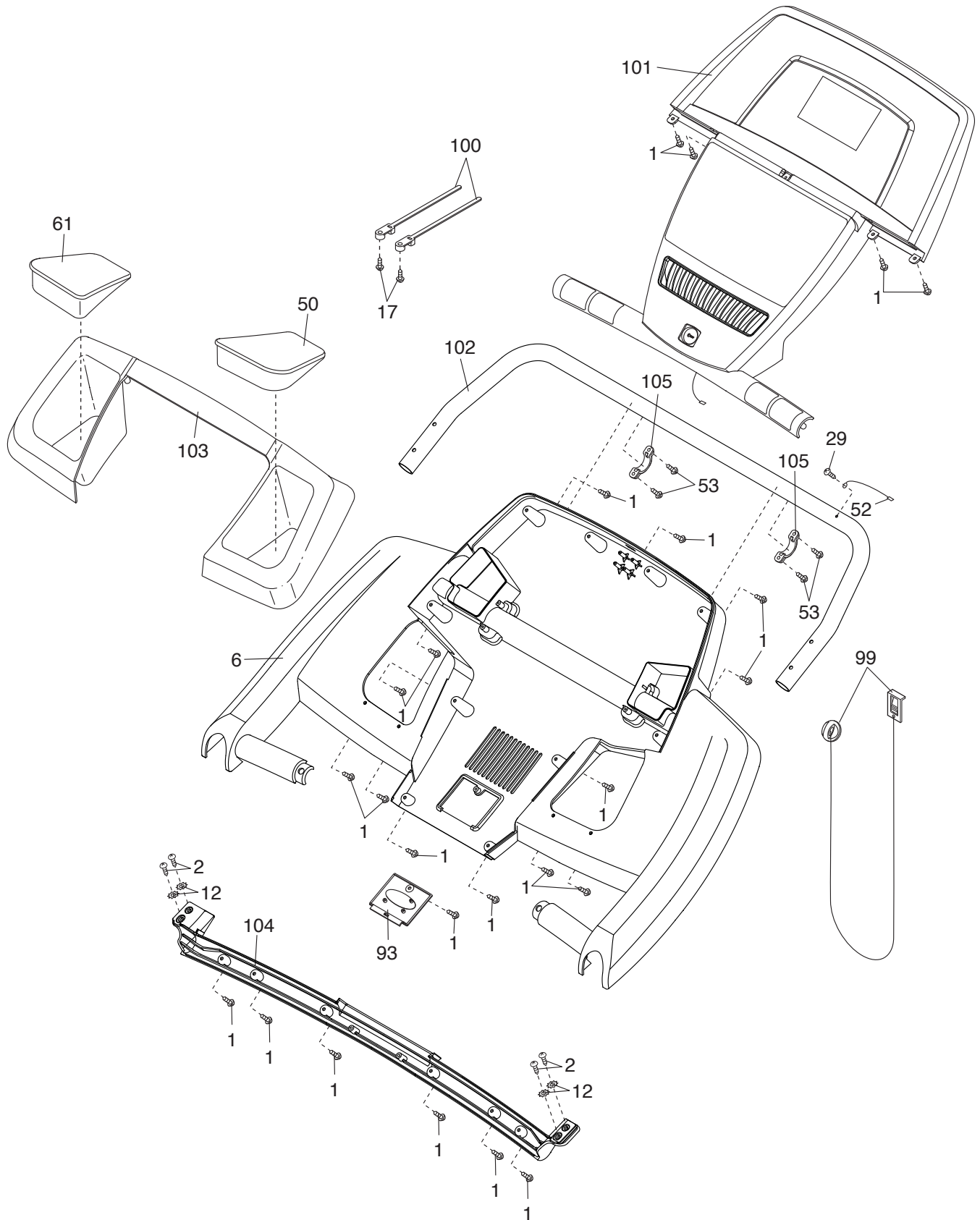

---

# ORDERING REPLACEMENT PARTS

To order replacement parts, please see the front cover of this manual. To help us assist you, be prepared to provide the following information when contacting us:

- the model number and serial number of the product (see the front cover of this manual)
- the name of the product (see the front cover of this manual)
- the key number and description of the replacement part(s) (see the PART LIST and the EXPLODED DRAWING near the end of this manual)

## LIMITED WARRANTY

**IMPORTANT: You must register this product within 30 days of the purchase date to avoid added fees for service needed under warranty. Go to [www.proformservice.com/registration](http://www.proformservice.com/registration).**

ICON Health & Fitness, Inc. (ICON) warrants this product to be free from defects in workmanship and material, under normal use and service conditions. The frame is warranted for a lifetime. The drive motor is warranted for twenty-five (25) years from the date of purchase. Parts and labor are warranted for one (1) year from the date of purchase.

This warranty extends only to the original purchaser (customer). ICON's obligation under this warranty is limited to repairing or replacing, at ICON's option, the product through one of its authorized service centers. All repairs for which warranty claims are made must be preauthorized by ICON. If the product is shipped to a service center, freight charges to and from the service center will be the customer's responsibility. If replacement parts are shipped while the product is under warranty, the customer will be responsible for a minimal handling charge. For in-home service, the customer will be responsible for a minimal trip charge. This warranty does not extend to freight damage to the product. This warranty will automatically be voided if the product is used as a store display model, if the product is purchased or transported outside the USA, if all instructions in this manual are not followed, if the product is abused or improperly or abnormally used, or if the product is used for commercial or rental purposes. No other warranty beyond that specifically set forth above is authorized by ICON.

ICON is not responsible or liable for indirect, special, or consequential damages arising out of or in connection with the use or performance of the product; damages with respect to any economic loss, loss of property, loss of revenues or profits, loss of enjoyment or use, or costs of removal or installation; or other consequential damages of any kind. Some states do not allow the exclusion or limitation of incidental or consequential damages. Accordingly, the above limitation may not apply to the customer.

The warranty extended hereunder is in lieu of any and all other warranties, and any implied warranties of merchantability or fitness for a particular purpose are limited in their scope and duration to the terms set forth herein. Some states do not allow limitations on how long an implied warranty lasts. Accordingly, the above limitation may not apply to the customer.

This warranty provides specific legal rights; the customer may have other rights that vary from state to state.

**ICON Health & Fitness, Inc., 1500 S. 1000 W., Logan, UT 84321-9813**