

# 525

# PRO-FORM®

PERFORMANCE TREADMILLS

Model No. PFTL52570

Serial No. \_\_\_\_\_

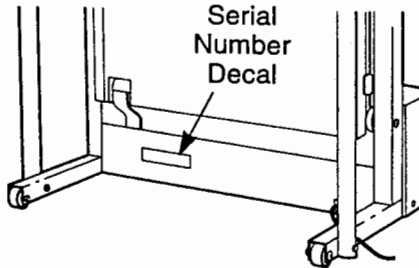

RELEASED TO  
AUG 05 1997  
MANUFACTURING

## QUESTIONS?

As a manufacturer, we are committed to providing complete customer satisfaction. If you have questions, or if there are missing or damaged parts, we will guarantee complete satisfaction through direct assistance from our factory.

TO AVOID UNNECESSARY DELAYS, PLEASE CALL DIRECT TO OUR TOLL-FREE CUSTOMER HOT LINE. The trained technicians on our Customer Hot Line will provide immediate assistance, free of charge to you.

CUSTOMER HOT LINE:  
**1-800-999-3756**  
Mon.-Fri., 6 a.m.-6 p.m. MST

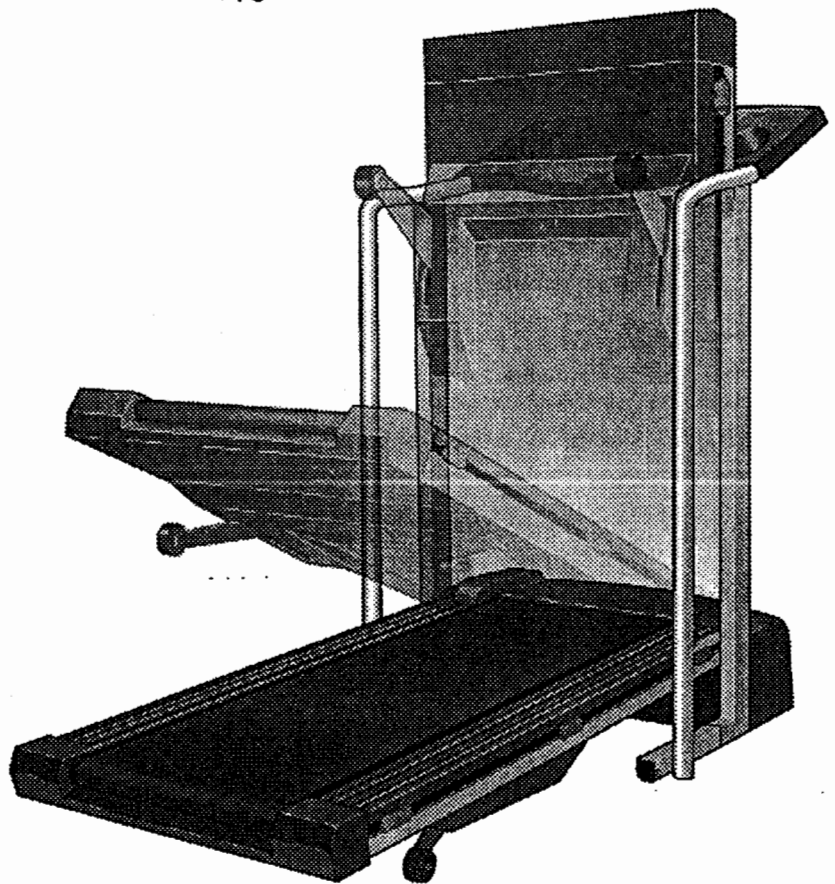

## **⚠ CAUTION**

Read all precautions and instructions in this manual before using this equipment. Save this manual for future reference.

# USER'S MANUAL

# TABLE OF CONTENTS

IMPORTANT PRECAUTIONS	2
BEFORE YOU BEGIN	4
ASSEMBLY	5
OPERATION AND ADJUSTMENT	7
HOW TO FOLD AND MOVE THE TREADMILL	10
MAINTENANCE AND TROUBLE-SHOOTING	12
CONDITIONING GUIDELINES	14
ORDERING REPLACEMENT PARTS	Back Cover
LIMITED WARRANTY	Back Cover

Note: An EXPLODED DRAWING and PART LIST are attached to the center of this manual. Please save them for future reference.

## IMPORTANT PRECAUTIONS

**⚠ WARNING:** To reduce the risk of burns, fire, electric shock, or injury to persons, read the following Important precautions and information before operating the treadmill.

1. It is the responsibility of the owner to ensure that all users of this treadmill are adequately informed of all warnings and precautions.
2. Use the treadmill only as described in this manual.
3. Place the treadmill on a level surface, with at least eight feet of clearance behind it. Do not place the treadmill on any surface that blocks air openings. To protect the floor or carpet from damage, place a mat under the treadmill.
4. Keep the treadmill indoors, away from moisture and dust. Do not put the treadmill in a garage or covered patio, or near water.
5. Do not operate the treadmill where aerosol products are used or where oxygen is being administered.
6. Keep children under the age of 12 and pets away from the treadmill at all times.
7. The treadmill should not be used by persons weighing more than 250 pounds.
8. Never allow more than one person on the treadmill at a time.
9. Wear appropriate exercise clothing when using the treadmill. Do not wear loose clothing that could become caught in the treadmill. Athletic support clothes are recommended for both men and women. *Always wear athletic shoes. Never use the treadmill with bare feet, wearing only stockings, or in sandals.*
10. When connecting the power cord (see HOW TO PLUG IN THE POWER CORD on page 7), plug the power cord into a surge protector (not included) and plug the surge protector into a grounded circuit capable of carrying 15 or more amps. No other appliance should be on the same circuit.
11. Use only a UL-listed surge protector, rated at 15 amps, with a 14-gauge cord of five feet or less in length. Do not use an extension cord.
12. Keep the power cord and the surge protector away from heated surfaces.
13. Never move the walking belt while the power is turned off. Do not operate the treadmill if the power cord or plug is damaged, or if the treadmill is not working properly. (See BEFORE YOU BEGIN on page 4 if the treadmill is not working properly.)

14. Never start the treadmill while you are standing on the walking belt. Always hold the handrails while using the treadmill.
15. The treadmill is capable of high speeds. Adjust the speed in small increments to avoid sudden jumps in speed.
16. To reduce the possibility of the treadmill overheating, do not operate the treadmill continuously for longer than 1 hour.
17. The pulse sensor is not a medical device. Various factors, including the user's movement, may affect the accuracy of heart rate readings. The pulse sensor is intended only as an exercise aid in determining heart rate trends in general.
18. Never leave the treadmill unattended while it is running.
19. Do not attempt to raise, lower, or move the treadmill until it is properly assembled. (See ASSEMBLY on page 5, and HOW TO MOVE

THE TREADMILL on page 11.) You must be able to safely lift 45 pounds (20 kg) in order to raise, lower, or move the treadmill.

20. When folding or moving the treadmill, make sure that the storage latch is fully closed.
21. Inspect and tighten all parts of the treadmill regularly.
22. Never insert any object into any opening.
23. Always unplug the power cord before performing the maintenance and adjustment procedures described in this manual. Never remove the motor hood unless instructed to do so by an authorized service representative. Servicing other than the procedures in this manual should be performed by an authorized service representative only.
24. This treadmill is intended for in-home use only. Do not use this treadmill in any commercial, rental, or institutional setting.

**⚠ WARNING:** Before beginning this or any exercise program, consult your physician. This is especially important for persons over the age of 35 or persons with pre-existing health problems. Read all Instructions before using. ICON assumes no responsibility for personal injury or property damage sustained by or through the use of this product.

## SAVE THESE INSTRUCTIONS

The decal shown below has been placed on your treadmill. If the decal is missing, or if it is not legible, please call our Customer Service Department, toll-free, to order a free replacement decal (see ORDERING REPLACEMENT PARTS on the back cover of this manual). Apply the decal in the location shown.

### ⚠ WARNING

- Never allow children to play on or around treadmill.
- Storage latch must be fully engaged before treadmill is moved or stored.

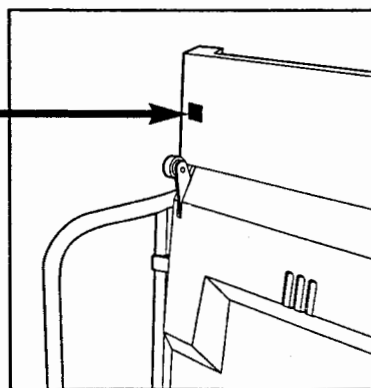

# BEFORE YOU BEGIN

Congratulations for purchasing the new PROFORM® 525 treadmill. The PROFORM 525 treadmill combines advanced technology with innovative design to let you enjoy an excellent form of cardiovascular exercise in the convenience and privacy of your home. And when you're not exercising, the unique PROFORM 525 can be folded up, requiring less than half the floor space of other treadmills.

**For your benefit, read this manual carefully before using the treadmill.** If you have additional questions, please call our Customer Service Department toll-free

at 1-800-999-3756, Monday through Friday, 6 a.m. until 6 p.m. Mountain Time (excluding holidays). To help us assist you, please note the product model number and serial number before calling. The model number of the treadmill is PFTL52570. The serial number can be found on a decal attached to the treadmill (see the front cover of this manual for the location).

Before reading further, please review the drawing below and familiarize yourself with the parts that are labeled.

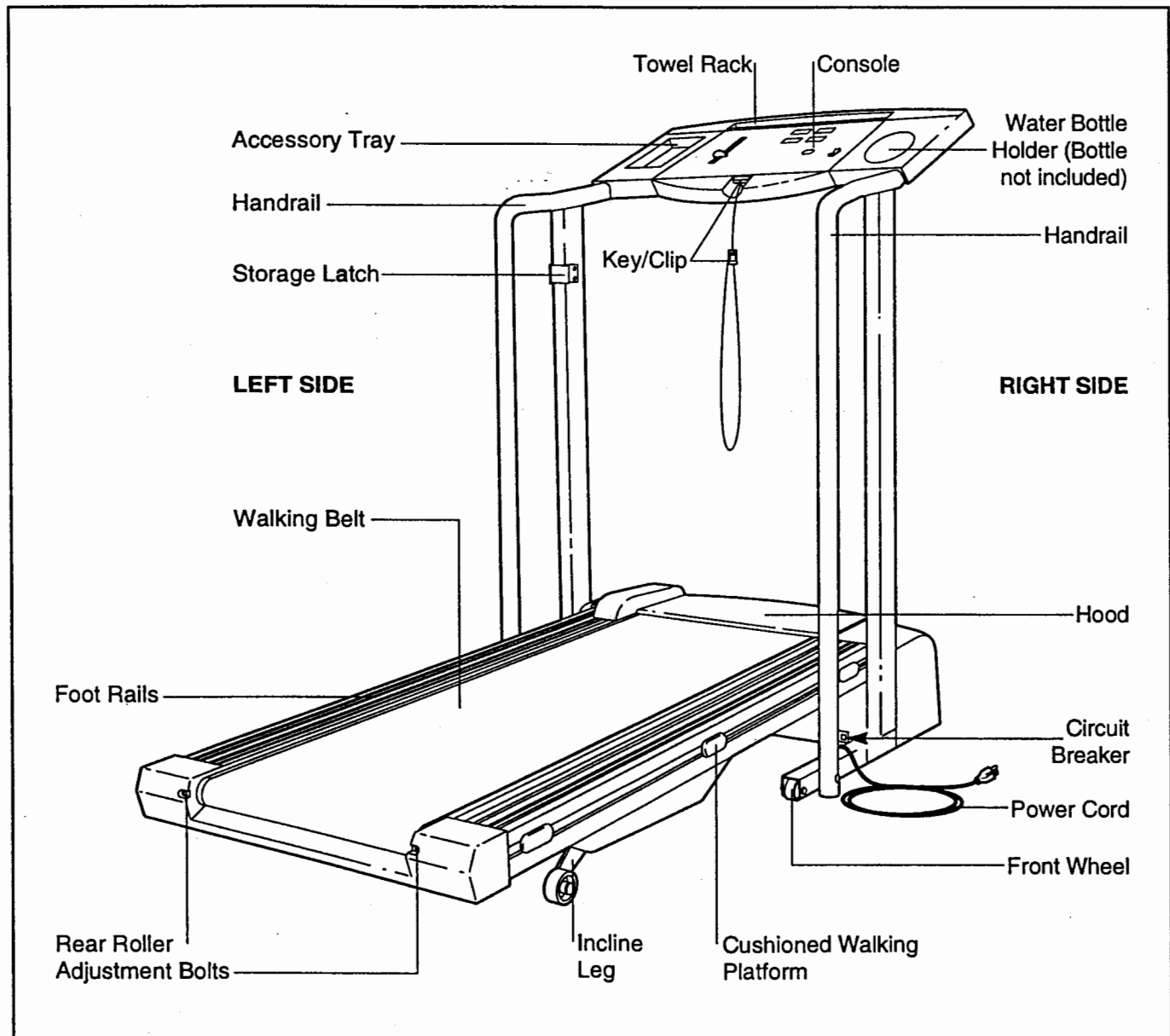

# ASSEMBLY

Assembly requires two people. Set the treadmill in a cleared area and remove all packing materials. Do not dispose of the packing materials until assembly is completed. Refer to the drawings below to identify the parts used in assembly. **Assembly requires the following tools: The Included allen wrench and your own phillips screwdriver and adjustable wrench.**

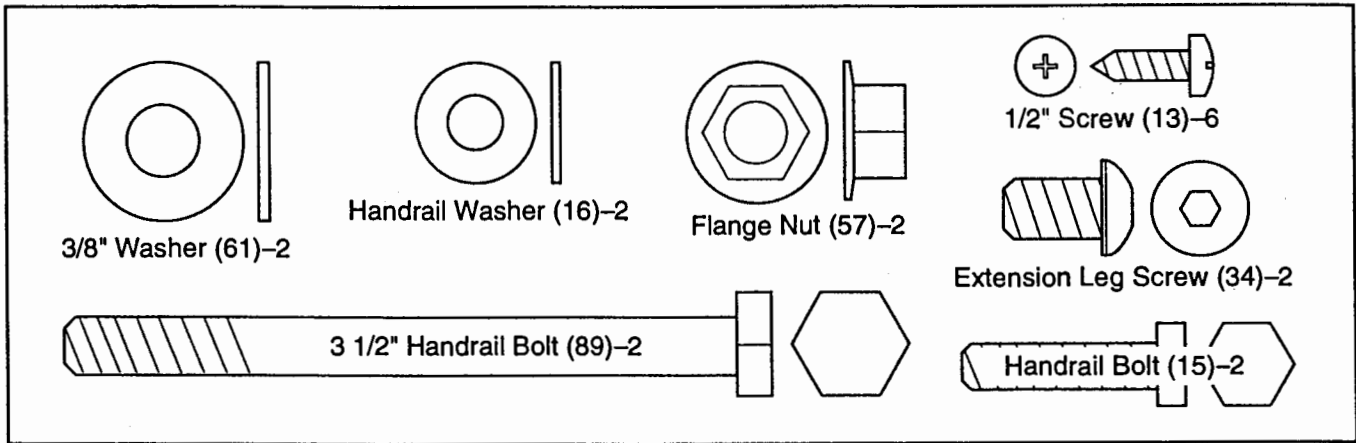

1. With the help of a second person, carefully lay the treadmill on its right side as shown (refer to the drawing on page 4 to identify the right side).

Insert the Extension Legs (41) into the treadmill. Make sure that the Extension Legs are turned so the Base Pads (36) are on the indicated side. Attach each Extension Leg with an Extension Leg Screw (34). Be sure to push on the heads of the Extension Leg Screws while tightening them.

With the help of a second person, carefully raise the treadmill to the upright position so the Extension Legs (41) are resting flat on the floor.

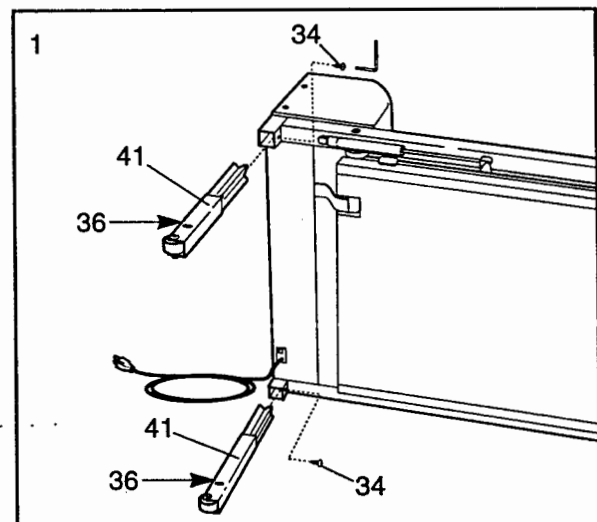

2. Refer to HOW TO LOWER THE TREADMILL FOR USE on page 11. Follow the instructions in step 2 to lower the treadmill.

Position the Left Handrail (2) on the left Upright (14) as shown. Thread a Handrail Bolt (15) with a Handrail Washer (16) into the left Upright and the Left Handrail. **Do not tighten the Handrail Bolt yet.**

Attach the lower end of the Left Handrail (2) to the Extension Leg (41) with a 3 1/2" Handrail Bolt (89), a 3/8" Washer (61), and a Flange Nut (57). **Do not tighten the Handrail Bolt yet.**

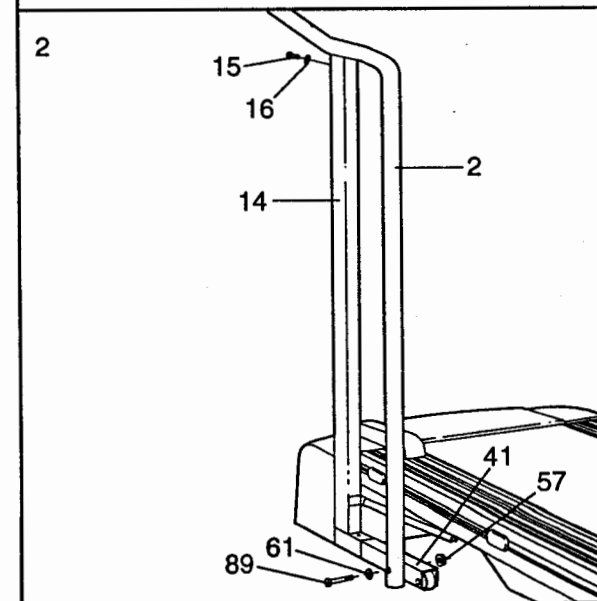

- With the help of a second person, hold the Console Base (6) and the Right Handrail (32) near the right Upright (14). Insert all excess Wire Harness (26) into the right Upright; if necessary, bend the Wire Harness as shown. Route the Wire Harness through the bracket on the Right Handrail and insert the bracket into the right Upright. **Make sure that the Wire Harness is not pinched.**

Refer to the inset drawing. Slide the Strain Relief Clip (88) onto the Wire Harness (26). Make sure that there is no slack Wire Harness between the Strain Relief Clip and the Console Base (6). Insert a 1/2" Screw (13) into the Strain Relief Clip and into the indicated hole in the Right Handrail (32). Tighten the Screw into the Console Base.

**IMPORTANT: The Strain Relief Clip (88) must be attached as instructed.**

- Attach the Console Base (6) to the Left and Right Handrails (2, 32) with three 1/2" Screws (13).
- Thread a Handrail Bolt (15) with a Handrail Washer (16) into the right Upright (14) and the Right Handrail (32). **Do not tighten the Handrail Bolt yet.**

Attach the lower end of the Right Handrail (32) to the Extension Leg (41) with a 3 1/2" Handrail Bolt (89), a 3/8" Washer (61), and a Flange Nut (57).

**Tighten all parts used in this step and in step 2.**

- Attach the Storage Latch (12) to the left Upright (14) with two 1/2" Screws (13). Be careful not to overtighten the Screws.

- Remove the backing from the Adhesive Clip (74). Press the Adhesive Clip onto the base of the Uprights (14) in the indicated location. Press the Allen Wrench (73) into the Adhesive Clip.

- Make sure that all parts are tightened before you use the treadmill. To protect the floor or carpet, place a mat under the treadmill.**

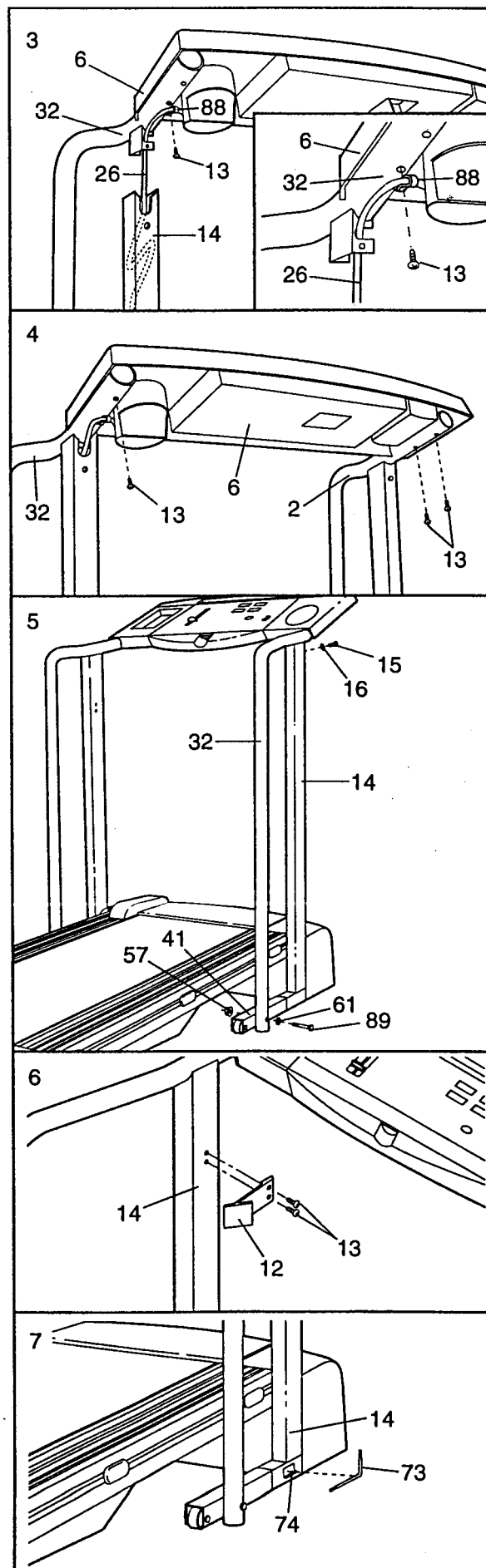

# OPERATION AND ADJUSTMENT

## THE PERFORMANT LUBE™ WALKING BELT

Your treadmill features a walking belt coated with PERFORMANT LUBE™, a high-performance lubricant. **Important: Never apply silicone spray or other substances to the walking belt or the walking platform. They will deteriorate the walking belt and cause excessive wear.**

## HOW TO PLUG IN THE POWER CORD

**⚠ DANGER:** Improper connection of the equipment-grounding conductor can result in an increased risk of electric shock. Check with a qualified electrician or serviceman if you are in doubt as to whether the product is properly grounded. Do not modify the plug provided with the product—if it will not fit the outlet, have a proper outlet installed by a qualified electrician.

Your treadmill, like any other type of sophisticated electronic equipment, can be seriously damaged by sudden voltage changes in your home's power. Voltage surges, spikes, and noise interference can result from weather conditions or from other appliances being turned on or off.

To decrease the possibility of your treadmill being damaged, always use a surge protector (not included) with your treadmill.

Surge protectors are sold at most hardware stores and department stores. Use only a UL-listed surge protector, rated at 15 amps, with a 14-gauge cord of five feet or less in length.

**This product must be grounded.** If it should malfunction or break down, grounding provides a path of least resistance for electric current to reduce the risk of

electric shock. This product is equipped with a cord having an equipment-grounding conductor and a grounding plug. **Plug the power cord into a surge protector, and plug the surge protector into an appropriate outlet that is properly installed and grounded in accordance with all local codes and ordinances.**

This product is for use on a nominal 120-volt circuit, and has a grounding plug that looks like the plug illustrated in drawing 1 below. A temporary adapter that looks like the adapter illustrated in drawing 2 may be used to connect the surge protector to a 2-pole receptacle as shown in drawing 2 if a properly grounded outlet is not available.

The temporary adapter should be used only until a properly grounded outlet (drawing 1) can be installed by a qualified electrician.

The green-colored rigid ear, lug, or the like extending from the adapter must be connected to a permanent ground such as a properly grounded outlet box cover. Whenever the adapter is used it must be held in place by a metal screw. **Some 2-pole receptacle outlet box covers are not grounded. Contact a qualified electrician to determine if the outlet box cover is grounded before using an adapter.**

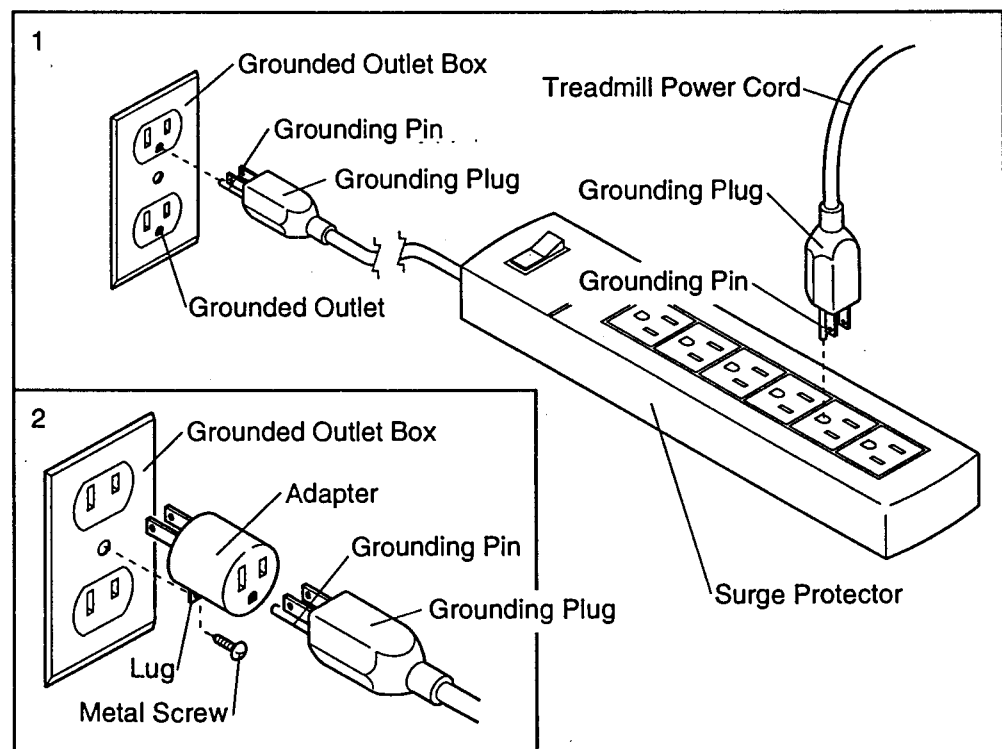

## DIAGRAM OF THE CONSOLE

Note: If there is a thin sheet of clear plastic on the face of the console, remove it.

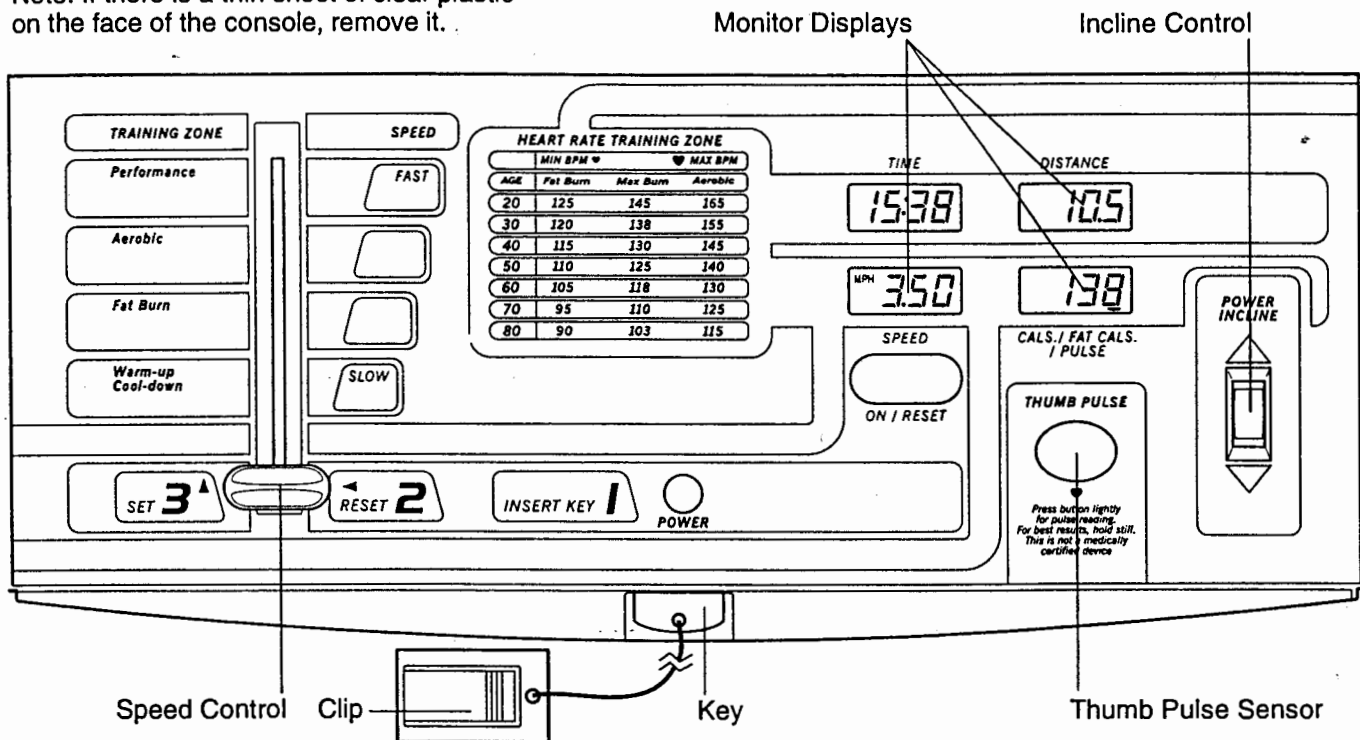

### **CAUTION:** Before operating the console, read the following precautions.

- Do not stand on the walking belt when turning on the power.
- Always wear the clip (see the drawing above) while operating the treadmill. When the key is removed from the console, the walking belt will stop.
- Adjust the speed in small increments.
- The training zones marked around the speed control are general guidelines only. See pages 14 and 15 for more information.
- To reduce the possibility of electric shock, keep the console dry. Avoid spilling liquids on the console. Use only a sealed water bottle.

## BATTERY INSTALLATION

The console requires three "AA" batteries (not included); alkaline batteries are recommended. To install batteries, open the battery cover as shown in the drawing at the right. Press the

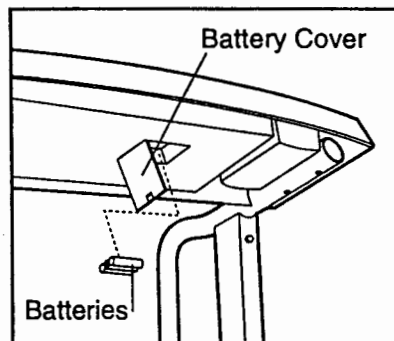

batteries into the battery compartment, with the negative ends of the batteries (marked "-") touching the springs. Close the battery cover.

## STEP BY STEP CONSOLE OPERATION

Step onto the foot rails of the treadmill. Find the clip attached to the key (see the drawing above), and slide the clip onto the waistband of your clothing.

Follow the steps on pages 9 and 10 to operate the console.

**1** Insert the key fully into the power switch.

Inserting the key will not turn on the displays. The displays will turn on when the ON/RESET button is pressed or when the walking belt is started. Note: If you just installed batteries, the displays will already be on.

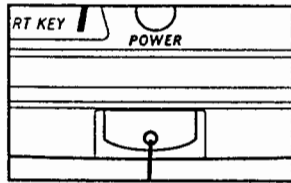

**2** Reset the speed control.

Slide the speed control down to the RESET position. Note: Each time the walking belt is stopped, the speed control must be moved to the RESET position before the walking belt can be restarted.

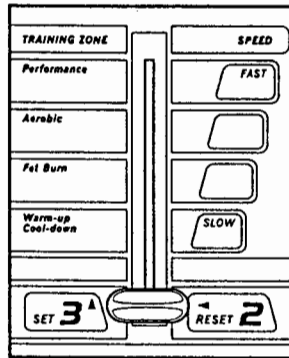

**3** Start the walking belt.

After you have moved the speed control to the RESET position, slide it slowly upward until the walking belt begins to move at slow speed. Carefully step onto the walking belt and begin exercising. Change the speed of the walking belt as desired by sliding the speed control.

To stop the walking belt, step onto the foot rails and slide the speed control to the RESET position.

**4** Change the incline of the treadmill, if desired.

To increase or decrease the incline, hold down the top or bottom of the incline control. Important: Do not change the incline of the treadmill by placing objects under the treadmill.

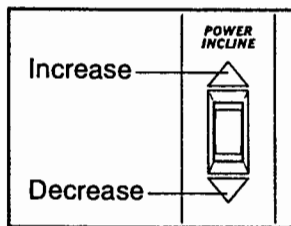

**5** Follow your progress with the monitor displays.

**TIME display**—This display shows the total time that you have walked or run on the treadmill.



**DISTANCE display**—This display shows the total distance that you have walked or run, in miles.

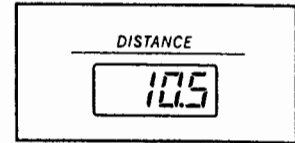

**SPEED display**—This display shows the speed of the walking belt, in miles per hour.

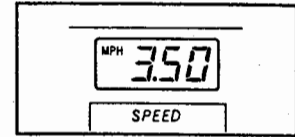

**CALORIES/FAT CALORIES/PULSE display**—This display shows the approximate numbers of calories and fat calories you have burned. (See FAT BURNING on page 12.) Every seven seconds, the display will change from one number to the other. Arrows in the display will indicate which number is currently shown. Note: This display also shows your pulse when the pulse sensor is used.

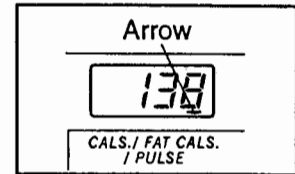

Note: The displays can be reset by pressing the ON/RESET button.

**6** Measure your pulse, if desired.

To use the pulse sensor, stand on the foot rails and place your thumb on the pulse sensor as shown.

The pulse sensor is pressure-activated—fully press down the pulse sensor. Do not press too hard, or the circulation in your thumb will be restricted, and your pulse will not be detected. Next, raise your thumb slightly until the heart-shaped indicator in the CALORIES/FAT CALORIES/PULSE display flashes steadily. Hold your thumb at this level.

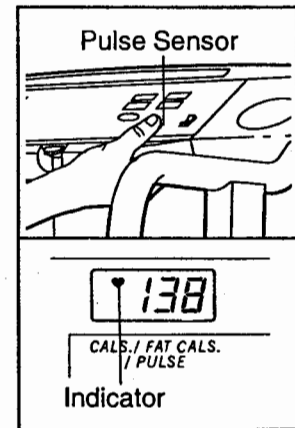

After 5 to 10 seconds, your pulse will be shown. Hold your thumb on the sensor for another 15 seconds for the most accurate reading. If the displayed pulse appears to be too high or too low, or if your pulse is not displayed, lift your thumb and allow the display to reset. Press down again on the sensor as described above.

Make sure that your thumb is positioned as shown, that you are applying the proper amount of pressure to the pulse sensor, and that you are standing still.

**7** When you are finished exercising, stop the walking belt and remove the key.

Step onto the foot rails, stop the walking belt, and remove the key from the console. Store the key in a secure place. After the key is removed, the displays will remain on for about five minutes.

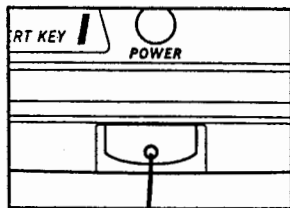

**Note:** Any time that the walking belt is stopped and no console buttons are pressed for five minutes, the displays will automatically turn off.

---

## HOW TO FOLD AND MOVE THE TREADMILL

### HOW TO FOLD THE TREADMILL FOR STORAGE

Before folding the treadmill, adjust the incline to the lowest position. If the incline is not at the lowest position, the treadmill will be permanently damaged. Next, unplug the power cord. **Caution:** You must be able to safely lift 45 pounds (20 kg) in order to raise, lower, or move the treadmill.

1. Hold the treadmill with your hands in the locations shown at the right. **Caution:** To decrease the possibility of injury, bend your legs and keep your back straight. As you raise the treadmill, make sure to lift with your legs rather than your back. Raise the treadmill about halfway to the vertical position.

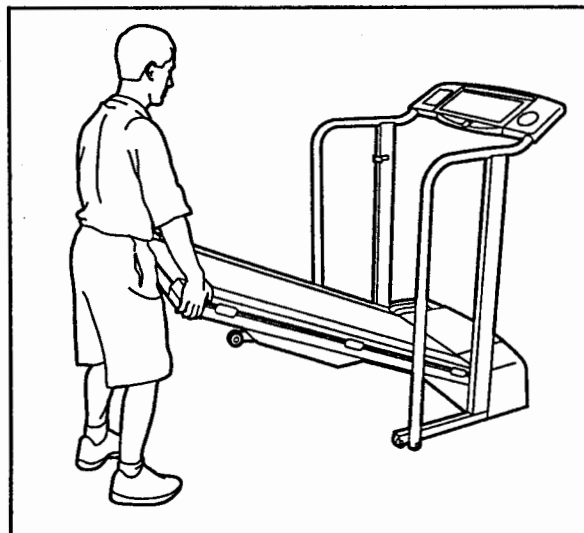

2. Move your right hand to the position shown and hold the treadmill firmly. Raise the treadmill until the storage latch closes over the catch. **Make sure that the storage latch is fully engaged over the catch.**

To protect the floor or carpet from damage, place a mat under the treadmill. Keep the treadmill out of direct sunlight. Do not leave the treadmill in the storage position in temperatures above 85° Fahrenheit.

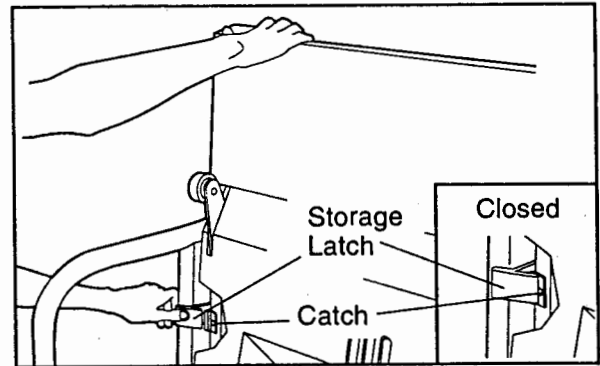

### HOW TO MOVE THE TREADMILL

Before moving the treadmill, convert the treadmill to the storage position as described above. **Make sure that the storage latch is closed fully over the catch.**

1. Hold the handrails and place one foot on the base as shown.
2. Tilt the treadmill back until it rolls freely on the front wheels. Carefully move the treadmill to the desired location. **Never move the treadmill without tipping it back, or the base pads may come off. To reduce the risk of injury, use extreme caution while moving the treadmill. Do not attempt to move the treadmill over an uneven surface.**
3. Place one foot on the base, and carefully lower the treadmill until it is resting in the storage position.

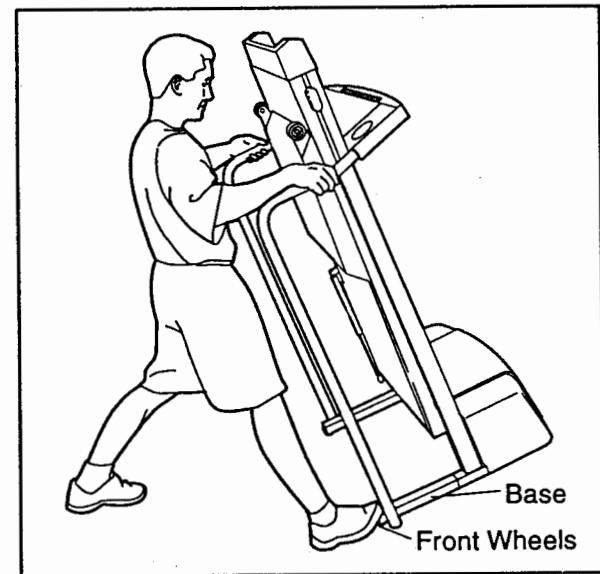

### HOW TO LOWER THE TREADMILL FOR USE

1. Hold the upper end of the treadmill with your right hand as shown. Using your left thumb, press the storage latch and hold it. Pivot the treadmill until the frame and foot rail are past the storage latch.

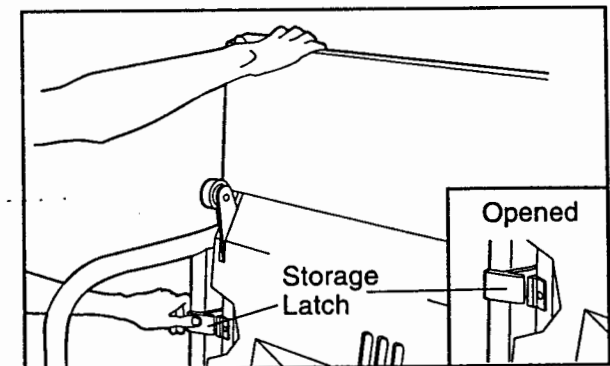

2. Hold the treadmill firmly with both hands, and lower the treadmill to the floor. **Caution: To decrease the possibility of injury, bend your legs and keep your back straight.**

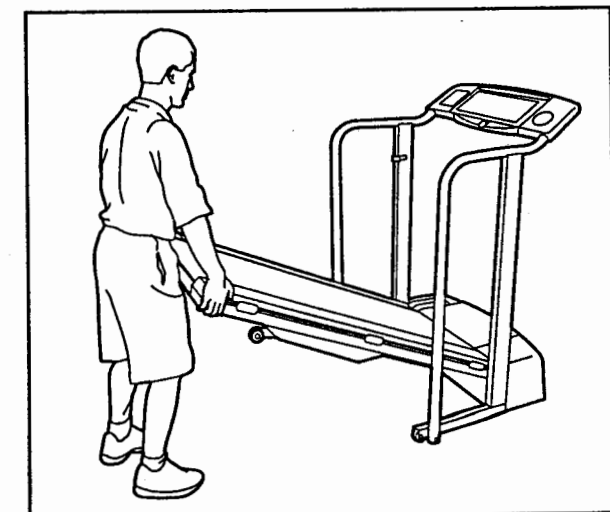

# MAINTENANCE AND TROUBLE-SHOOTING

Most treadmill problems can be solved by following the steps below. Find the symptom that applies, and follow the steps listed. If further assistance is needed, please call our Customer Service Department toll-free at 1-800-999-3756, Monday through Friday, 6 a.m. until 6 p.m. Mountain Time (excluding holidays).

## 1. SYMPTOM: THE POWER DOES NOT TURN ON

- a. Make sure that the power cord is plugged into a surge protector, and that the surge protector is plugged into a properly grounded outlet. (See HOW TO PLUG IN THE POWER CORD on page 7.) Use only a UL-listed surge protector, rated at 15 amps, with a 14-gauge cord of five feet or less in length.
- b. After the power cord has been plugged in, make sure that the key is fully inserted into the console. (See step 1 on page 9.)
- c. Check the circuit breaker located on the treadmill near the power cord. If the switch protrudes as shown, the circuit breaker has tripped. To reset the circuit breaker, wait for five minutes and then press the switch back in.

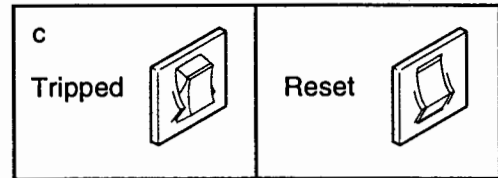

## 2. SYMPTOM: THE POWER TURNS OFF DURING USE

- a. Check the circuit breaker located on the treadmill frame near the power cord (see 1. c. above). If the circuit breaker has tripped, wait for five minutes and then press the switch back in.
- b. Make sure that the power cord is plugged in.
- c. Remove the key from the console. Reinsert the key fully into the console. (See step 1 on page 9.)
- d. If the treadmill still will not run, please call our Customer Service Department, toll-free.

## 3. SYMPTOM: THE DISPLAYS OF THE CONSOLE DO NOT FUNCTION PROPERLY

- a. Check the batteries in the console. See BATTERY INSTALLATION on page 8. Most problems are the result of drained batteries.
- b. Remove the six screws from the hood. Carefully remove the hood. Locate the Reed Switch (86) and the Magnet (87) on the left side of the Pulley (85). Turn the Pulley until the Magnet is aligned with the Reed Switch. **Make sure that the gap between the Magnet and the Reed Switch is about 1/8".** If necessary, loosen the Screw (35) and move the Reed Switch slightly. Retighten the Screw. Re-attach the hood, and run the treadmill for a few minutes to check for a correct speed reading.

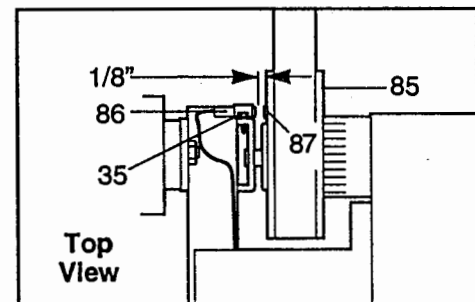

#### 4. SYMPTOM: THE WALKING BELT SLOWS WHEN WALKED ON

- a. Use only a UL-listed surge protector, rated at 15 amps, with a 14-gauge cord of five feet or less in length.
- b. If the walking belt is overtightened, treadmill performance may decrease and the walking belt may be permanently damaged. Remove the key and **UNPLUG THE POWER CORD**. Using the allen wrench, turn both rear roller adjustment bolts counterclockwise, 1/4 of a turn. When the walking belt is properly tightened, you should be able to lift each side of the walking belt 3 to 4 inches off the walking platform. The center of the walking belt should just touch the walking platform. Be careful to keep the walking belt centered. Plug in the power cord, insert the key and run the treadmill for a few minutes. Repeat until the walking belt is properly tightened.

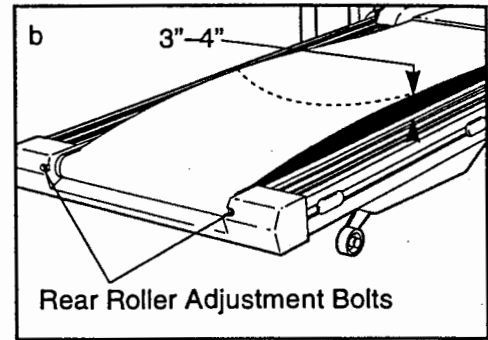

- c. If the walking belt still slows when walked on, please call our toll-free Customer Service Department.

#### 5. SYMPTOM: THE WALKING BELT IS OFF-CENTER WHEN WALKED ON

- a. If the walking belt has shifted to the left, first remove the key and **UNPLUG THE POWER CORD**. Using the allen wrench, turn the left rear roller adjustment bolt clockwise, and the right bolt counterclockwise, 1/4 of a turn each. Be careful not to overtighten the walking belt. Plug in the power cord, insert the key and run the treadmill for a few minutes. Repeat until the walking belt is centered.

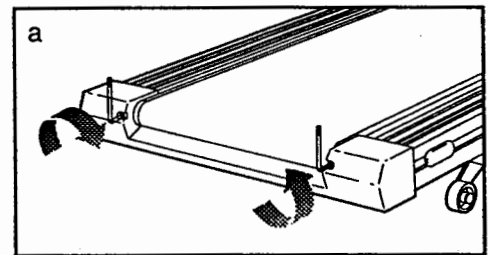

- b. If the walking belt has shifted to the right, first remove the key and **UNPLUG THE POWER CORD**. Using the allen wrench, turn the left rear roller adjustment bolt counterclockwise, and the right bolt clockwise, 1/4 of a turn each. Be careful not to overtighten the walking belt. Plug in the power cord, insert the key and run the treadmill for a few minutes. Repeat until the walking belt is centered.

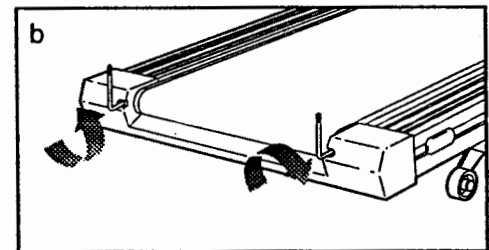

- c. If the walking belt slips when walked on, first remove the key and **UNPLUG THE POWER CORD**. Using the allen wrench, turn both rear roller adjustment bolts clockwise, 1/4 of a turn. When the walking belt is correctly tightened, you should be able to lift each side of the walking belt 2 to 3 inches off the walking platform. The center of the walking belt should just touch the walking platform. Be careful to keep the walking belt centered. Plug in the power cord, insert the key and run the treadmill for a few minutes. Repeat until the walking belt is properly tightened.

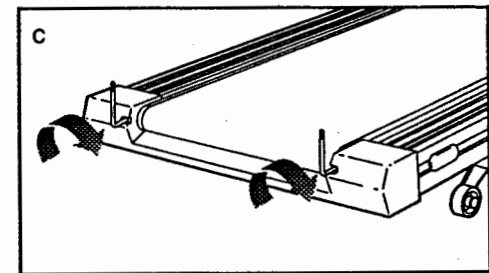

# CONDITIONING GUIDELINES

**⚠ WARNING:** Before beginning this or any exercise program, consult your physician. This is especially important for individuals over the age of 35 or individuals with pre-existing health problems.

The pulse sensor is not a medical device. Various factors, including your movement, may affect the accuracy of heart rate readings. The sensor is intended only as an exercise aid in determining heart rate trends in general.

The following guidelines will help you to plan your exercise program. Remember—these are general guidelines only. For more detailed exercise information, obtain a reputable book or consult your physician.

## EXERCISE INTENSITY

Whether your goal is to burn fat or to strengthen your cardiovascular system, the key to achieving the desired results is to exercise with the proper intensity. The proper intensity level can be found by using your heart rate as a guide. The chart below shows recommended heart rates for fat burning and aerobic exercise.

HEART RATE TRAINING ZONE			
	MIN BPM	MAX BPM	
AGE	Fat Burn	Max Burn	Aerobic
20	125	145	165
30	120	138	155
40	115	130	145
50	110	125	140
60	105	118	130
70	95	110	125
80	90	103	115

To find the proper heart rate for you, first find your age on the left side of the chart (ages are rounded off to the nearest ten years). Next, find the three numbers to the right of your age. The three numbers are your "training zone." The lower two numbers are recommended heart rates for fat burning; the higher number is the recommended heart rate for aerobic exercise.

To measure your heart rate during exercise, use the pulse sensor on the console. (See page 9.) If your heart rate is too high or too low, adjust the speed or incline of the treadmill as needed.

## Fat Burning

To burn fat effectively, you must exercise at a relatively low intensity level for a sustained period of time. During the first few minutes of exercise, your body uses easily accessible *carbohydrate calories* for energy. Only after the first few minutes does your body begin to use stored *fat calories* for energy. If your goal is to burn fat, adjust the speed and incline of the treadmill until your heart rate is near one of the lower two numbers in your training zone. It may also be helpful to set the speed control on the console to FAT BURN to help you maintain the proper intensity level. (See page 9.)

## Aerobic Exercise

If your goal is to strengthen your cardiovascular system, your exercise must be "aerobic." Aerobic exercise is activity that requires large amounts of oxygen for prolonged periods of time. This increases the demand on the heart to pump blood to the muscles, and on the lungs to oxygenate the blood. For aerobic exercise, adjust the speed and incline of the treadmill until your heart rate is near the higher number in your training zone. It may also be helpful to set the speed control on the console to AEROBIC to help you maintain the proper intensity level. (See page 9.)

## High Performance Athletic Conditioning

If your goal is high performance athletic conditioning, set the speed control on the console to PERFORMANCE to help you maintain the proper intensity level. (See page 9.) Note: During the first few weeks of your exercise program, keep your heart rate near the low end of your training zone.

## WORKOUT GUIDELINES

Each workout should include the following three parts:

### A Warm-up

Start each workout with 5 to 10 minutes of stretching and light exercise. A proper warm-up increases your body temperature, heart rate, and circulation in preparation for strenuous exercise.

### Training Zone Exercise

After warming up, increase the intensity of your exercise until your heart rate is in your training zone for 20 to 60 minutes. (During the first few weeks of your exercise program, do not keep your heart rate in your training zone for longer than 20 minutes.) Breathe regularly and deeply as you exercise—never hold your breath.

## A Cool-down

Finish each workout with 5 to 10 minutes of stretching to cool down. This will increase the flexibility of your muscles and will help to prevent post-exercise problems.

## Exercise Frequency

To maintain or improve your condition, complete three workouts each week, with at least one day of rest between workouts. After a few months of regular exercise, you may complete up to five workouts each week if desired. *The key to success is to make exercise a regular and enjoyable part of your everyday life.*

## SUGGESTED STRETCHES

The correct form for several basic stretches is described below. Move slowly as you stretch—never bounce.

### 1. Toe Touch Stretch

Stand with your knees bent slightly and slowly bend forward from your hips. Allow your back and shoulders to relax as you reach down toward your toes as far as possible. Hold for 15 counts, then relax. Repeat 3 times. Stretches: Hamstrings, back of knees and back.

### 2. Hamstring Stretch

Sit with one leg extended. Bring the sole of the opposite foot toward you and rest it against the inner thigh of your extended leg. Reach toward your toes as far as possible. Hold for 15 counts, then relax. Repeat 3 times for each leg. Stretches: Hamstrings, lower back and groin.

### 3. Calf/Achilles Stretch

With one leg in front of the other, reach forward and place your hands against a wall. Keep your back leg straight and your back foot flat on the floor. Bend your front leg, lean forward and move your hips toward the wall. Hold for 15 counts, then relax. Repeat 3 times for each leg. To cause further stretching of the achilles tendons, bend your back leg as well. Stretches: Calves, achilles tendons and ankles.

### 4. Quadriceps Stretch

With one hand against a wall for balance, reach back and grasp one foot with your other hand. Bring your heel as close to your buttocks as possible. Hold for 15 counts, then relax. Repeat 3 times for each leg. Stretches: Quadriceps and hip muscles.

### 5. Inner Thigh Stretch

Sit with the soles of your feet together and your knees outward. Pull your feet toward your groin area as far as possible. Hold for 15 counts, then relax. Repeat 3 times. Stretches: Quadriceps and hip muscles.

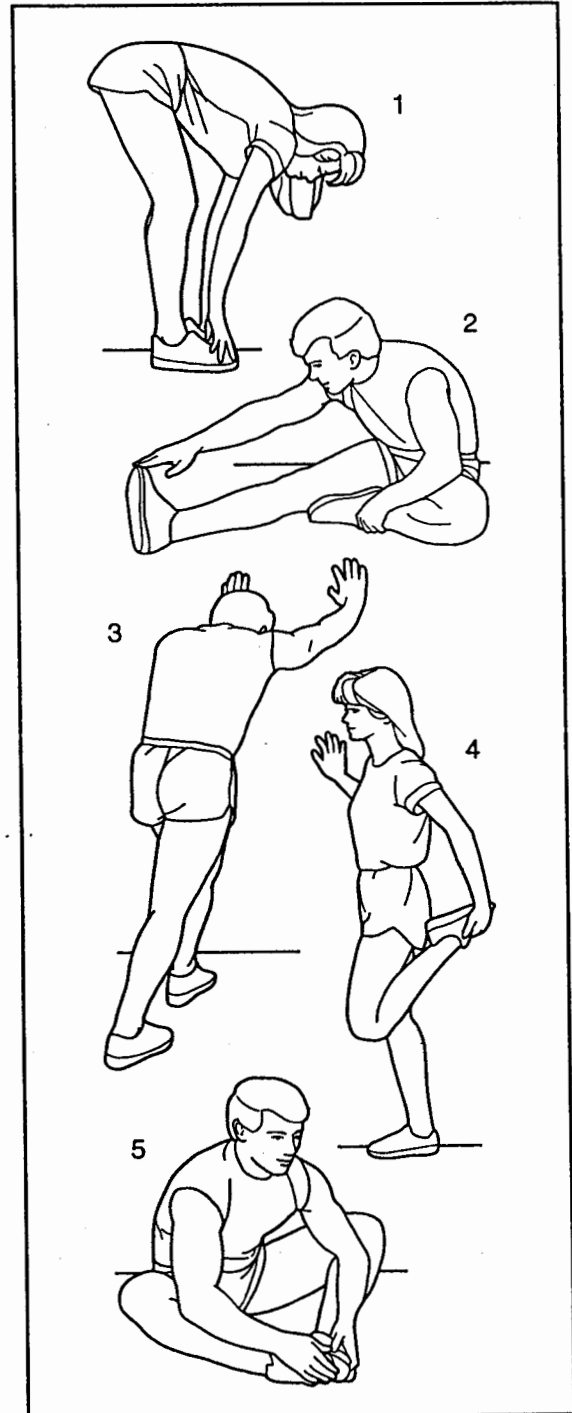

# ORDERING REPLACEMENT PARTS

To order replacement parts, call our Customer Service Department toll-free at 1-800-999-3756, Monday through Friday, 6 a.m. until 6 p.m. Mountain Time (excluding holidays). When ordering parts, please be prepared to give the following information:

- The MODEL NUMBER OF THE PRODUCT (PFTL52570).
- The NAME OF THE PRODUCT (PROFORM® 525 treadmill).
- The SERIAL NUMBER OF THE PRODUCT (see the front cover of this manual).
- The KEY NUMBER OF THE PART(S) (see the EXPLODED DRAWING and PART LIST attached to the center of this manual).
- The DESCRIPTION OF THE PART(S) (see the EXPLODED DRAWING and PART LIST attached to the center of this manual).

If possible, place the treadmill near your telephone for easy reference when calling.

PROFORM is a registered trademark of ICON Health & Fitness, Inc.

## LIMITED WARRANTY

ICON Health & Fitness, Inc. (ICON), warrants this product to be free from defects in workmanship and material, under normal use and service conditions, for a period of ninety (90) days from the date of purchase. This warranty extends only to the original purchaser. ICON's obligation under this warranty is limited to replacing or repairing, at ICON's option, the product at one of its authorized service centers. All products for which warranty claim is made must be received by ICON at one of its authorized service centers with all freight and other transportation charges prepaid, accompanied by sufficient proof of purchase. All returns must be pre-authorized by ICON. This warranty does not extend to any product or damage to a product caused by or attributable to freight damage, abuse, misuse, improper or abnormal usage or repairs not provided by an ICON authorized service center, to products used for commercial or rental purposes, or to products used as store display models. No other warranty beyond that specifically set forth above is authorized by ICON.

ICON is not responsible or liable for indirect, special or consequential damages arising out of or in connection with the use or performance of the product or damages with respect to any economic loss, loss of property, loss of revenues or profits, loss of enjoyment or use, costs of removal, installation or other consequential damages of whatsoever nature. Some states do not allow the exclusion or limitation of incidental or consequential damages. Accordingly, the above limitation may not apply to you.

The warranty extended hereunder is in lieu of any and all other warranties and any implied warranties of merchantability or fitness for a particular purpose is limited in its scope and duration to the terms set forth herein. Some states do not allow limitations on how long an implied warranty lasts. Accordingly, the above limitation may not apply to you.

This warranty gives you specific legal rights. You may also have other rights which vary from state to state.

**ICON HEALTH & FITNESS, INC., 1500 S. 1000 W., LOGAN, UT 84321-9813**

**REMOVE THIS EXPLODED DRAWING  
AND PART LIST FROM THE MANUAL.  
Save this page for future reference.**

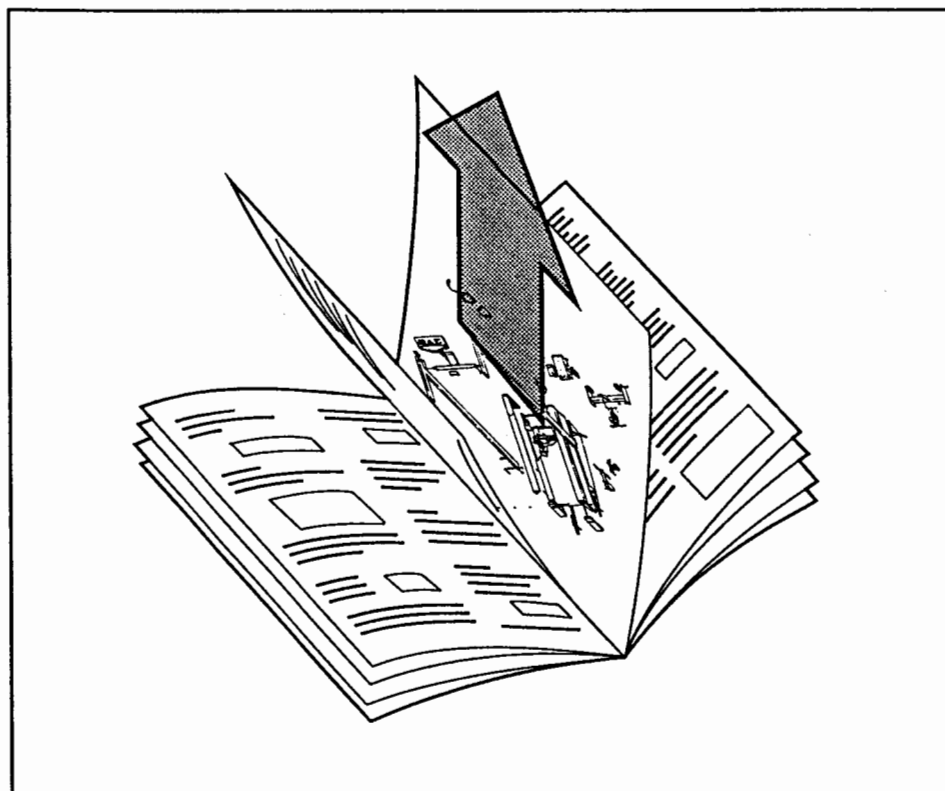

Note: Specifications are subject to change without notice. For information about ordering replacement parts, see the back cover of the User's Manual.

EXPLODED DRAWING—Model No. PFTL52570

R0797A

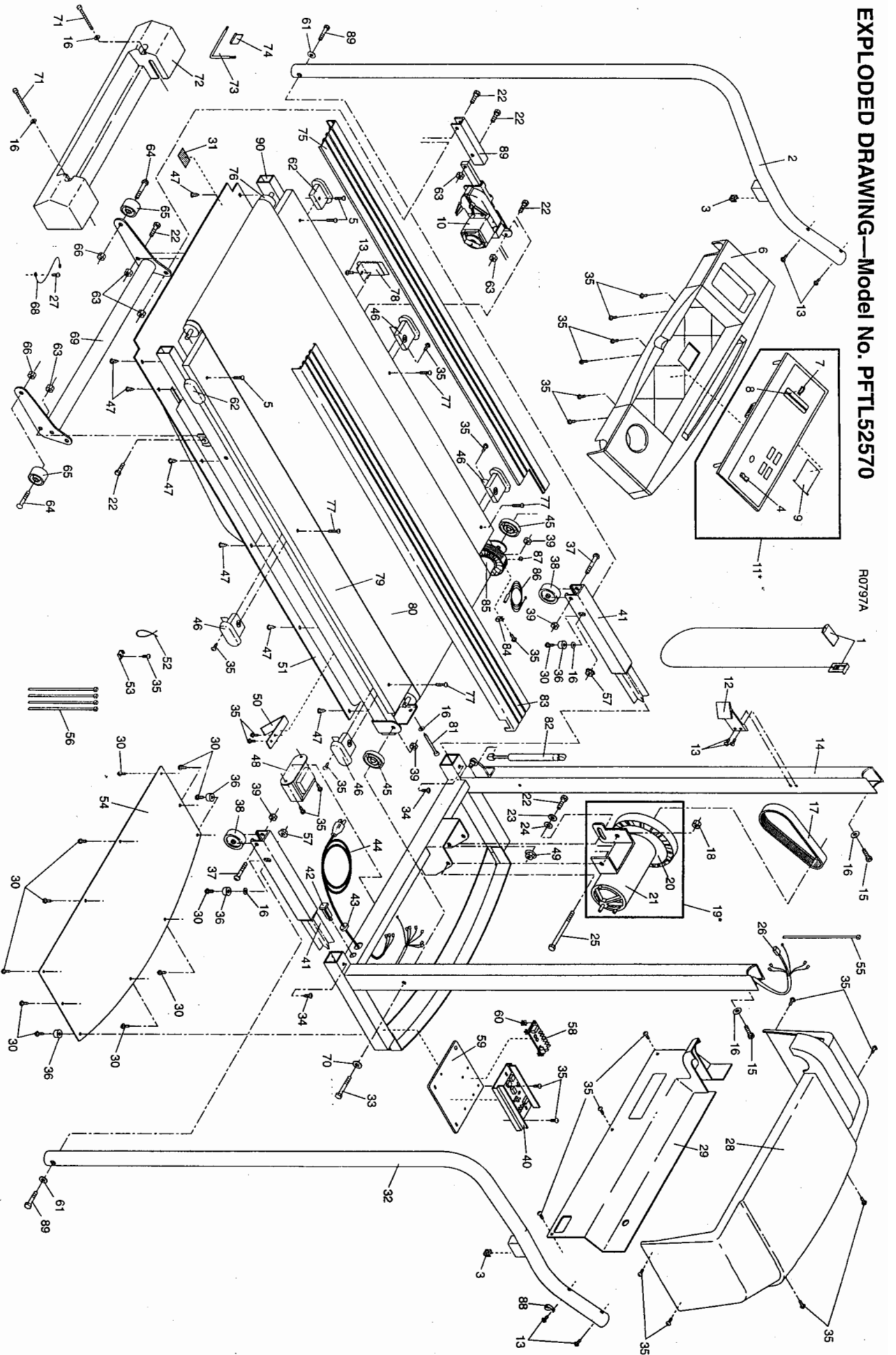

# PART LIST—Model No. PFTL52570

R0797A

Key No.	Qty.	Description	Key No.	Qty.	Description
1	1	Key/Clip	50	2	Belt Guide
2	1	Left Handrail	51	1	Belly Pan
3	2	Cage Nut	52	1	Releasable Tie
4	1	Incline Control	53	1	Cable Tie Clamp
5	4	Rear Isolator Screw	54	1	Motor Belly Pan
6	1	Console Base	55	1	11 1/2" Cable Tie
7	1	Speed Control Knob	56	4	8" Cable Tie
8	1	Speed Potentiometer	57	2	Flange Nut
9	1	Battery Cover	58	1	Lift Board
10	1	Incline Motor	59	1	Electronics Plate
11*	1	Console Assembly	60	4	Plastic Stand-Off
12	1	Storage Latch	61	2	3/8" Washer
13	7	1/2" Screw	62	2	Solid Isolator
14	1	Upright/Base	63	9	Incline Nut
15	2	Handrail Bolt	64	2	Incline Wheel Bolt
16	7	Handrail Washer	65	2	Incline Wheel
17	1	Motor Belt	66	2	Incline Wheel Nut
18	1	Motor Swivel Nut	67	3	Incline Bolt
19*	1	Motor/Pulley/Flywheel/Fan	68	1	Ground Wire
20	1	Pulley/Flywheel/Fan	69	1	Incline Leg
21	1	Motor	70	2	Upright Pivot Washer
22	6	Motor Tension Bolt/Incline Bolt	71	2	Rear Roller Adj. Bolt
23	1	Motor Tension Washer	72	1	Rear Roller Endcap
24	1	Motor Tension Star Washer	73	1	Allen Wrench
25	1	Motor Swivel Bolt	74	1	Adhesive Clip
26	1	Wire Harness	75	1	Left Foot Rail
27	2	Ground Wire Screw	76	1	Rear Roller
28	1	Hood	77	4	Platform Screw
29	1	Hood Shield	78	1	Latch Catch
30	10	Screw	79	1	Walking Platform
31	1	Latch Decal	80	1	Walking Belt
32	1	Right Handrail	81	1	Front Roller Adjustment Bolt
33	2	Frame Pivot Bolt	82	1	Shock
34	2	Extension Leg Screw	83	1	Right Foot Rail
35	29	Electronics Screw	84	1	Sensor Clip
36	6	Base Pad	85	1	Front Roller/Pulley
37	2	Wheel Bolt	86	1	Reed Switch
38	2	Wheel	87	1	Magnet
39	3	Wheel Nut/Base Pivot Nut	88	1	Strain Relief Clip
40	1	Controller	89	2	3 1/2" Handrail Bolt
41	2	Extension Leg	90	1	Frame
42	1	Circuit Breaker	#	1	14" White Wire, Male/Female
43	1	Power Cord Grommet	#	1	8" White Wire, 2 Female
44	1	Power Cord	#	1	8" Blue Wire, 2 Female
45	2	Upright Spacer	#	1	8" Blue Wire, Male/Female
46	4	Isolator	#	1	8" Red Wire, Male/Female
47	10	Belly Pan Fastener	#	1	User's Manual
48	1	Choke			
49	1	Motor Locknut			

\* Includes all parts shown in the box

# These parts are not illustrated