

# PRO-FORM<sup>®</sup> POWER 995c

[www.proform.com](http://www.proform.com)

Model No. PFTL99912.2

Serial No. \_\_\_\_\_

Write the serial number in the space above for reference.

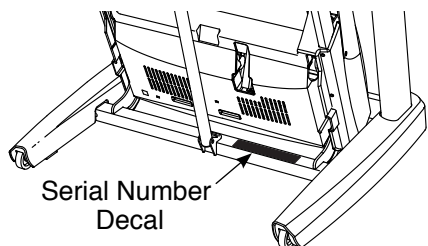

## USER'S MANUAL

### QUESTIONS?

If you have questions, or if parts are damaged or missing, **DO NOT CONTACT THE STORE**; please contact Customer Care.

**IMPORTANT:** Please register this product (see the limited warranty on the back cover of this manual) before contacting Customer Care.

CALL TOLL-FREE:

**1-888-533-1333**

Mon.–Fri. 6 a.m.–6 p.m. MT

Sat. 8 a.m.–12 p.m. MT

ON THE WEB:

[www.proformservice.com](http://www.proformservice.com)

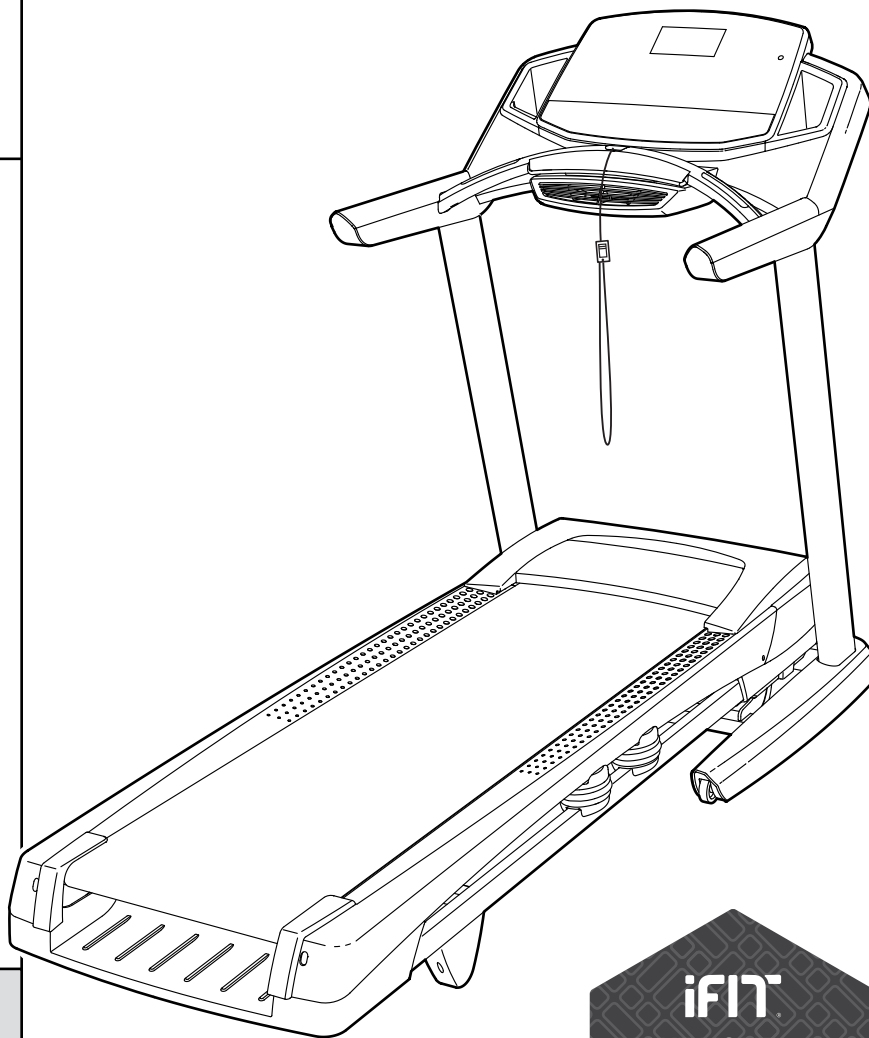

### CAUTION

Read all precautions and instructions in this manual before using this equipment. Save this manual for future reference.



# TABLE OF CONTENTS

WARNING DECAL PLACEMENT ..... 2

IMPORTANT PRECAUTIONS ..... 3

BEFORE YOU BEGIN ..... 5

PART IDENTIFICATION CHART ..... 6

ASSEMBLY ..... 7

THE CHEST HEART RATE MONITOR ..... 15

HOW TO USE THE TREADMILL ..... 16

HOW TO FOLD AND MOVE THE TREADMILL ..... 25

MAINTENANCE AND TROUBLESHOOTING ..... 26

EXERCISE GUIDELINES ..... 29

PART LIST ..... 30

EXPLODED DRAWING ..... 32

ORDERING REPLACEMENT PARTS ..... Back Cover

LIMITED WARRANTY ..... Back Cover



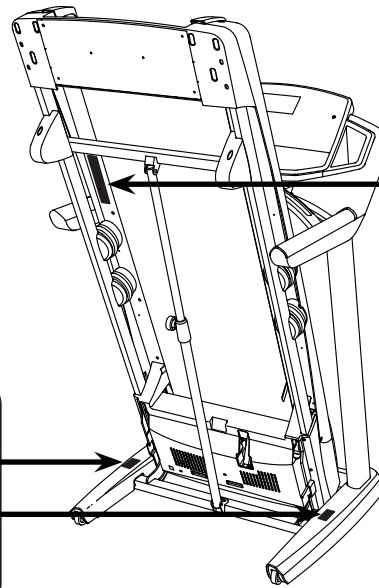

## WARNING DECAL PLACEMENT

This drawing shows the locations of the warning decals. **If a decal is missing or illegible, call the telephone number on the front cover of this manual and request a free replacement decal. Apply the decal in the location shown.** Note: The decals may not be shown at actual size.



**▲WARNING:**

Protect yourself and others from risk of serious injury. Read the user's manual and:

-  •Stand only on the side rails when starting or stopping treadmill.
- Change speed in small increments.
- Hold handrails to prevent falling, and always wear the safety clip while operating treadmill.
- Stop if you feel faint, dizzy, or short of breath.
- Fully engage storage latch before treadmill is moved or stored.
- Reduce incline to its lowest level before folding treadmill into storage position.
-  •Never allow children on or around treadmill.
- Remove key when not in use.
-  •Keep clothing, fingers, and hair away from moving belt.
- Never try to adjust or fix the belt while it is moving.
-  •Always wear athletic shoes while operating treadmill.

# IMPORTANT PRECAUTIONS

**⚠️ WARNING:** To reduce the risk of burns, fire, electric shock, or injury to persons, read all important precautions and instructions in this manual and all warnings on your treadmill before using your treadmill. ICON assumes no responsibility for personal injury or property damage sustained by or through the use of this product.

1. It is the responsibility of the owner to ensure that all users of this treadmill are adequately informed of all warnings and precautions.
2. Before beginning any exercise program, consult your physician. This is especially important for persons over age 35 or persons with pre-existing health problems.
3. Use the treadmill only as described in this manual.
4. The treadmill is intended for home use only. Do not use the treadmill in any commercial, rental, or institutional setting.
5. Keep the treadmill indoors, away from moisture and dust. Do not put the treadmill in a garage or covered patio, or near water.
6. Place the treadmill on a level surface, with at least 8 ft. (2.4 m) of clearance behind it and 2 ft. (0.6 m) on each side. Do not place the treadmill on any surface that blocks air openings. To protect the floor or carpet from damage, place a mat under the treadmill.
7. Do not operate the treadmill where aerosol products are used or where oxygen is being administered.
8. Keep children under age 12 and pets away from the treadmill at all times.
9. The treadmill should be used only by persons weighing 350 lbs. (159 kg) or less.
10. Never allow more than one person on the treadmill at a time.
11. Wear appropriate exercise clothes while using the treadmill. Do not wear loose clothes that could become caught in the treadmill. Athletic support clothes are recommended for both men and women. *Always wear athletic shoes. Never use the treadmill with bare feet, wearing only stockings, or in sandals.*
12. Plug the power cord into a surge suppressor (not included), and plug the surge suppressor into an appropriate outlet (see page 16). To avoid overloading the circuit, do not plug other electrical devices, except for low-power devices such as cell phone chargers, into the surge suppressor or into an outlet on the same circuit.
13. Use only a surge suppressor that meets all of the specifications described on page 16. To purchase a surge suppressor, see your local PROFORM dealer, call the telephone number on the front cover of this manual, or see your local electronics store.
14. Failure to use a properly functioning surge suppressor could result in damage to the control system of the treadmill. If the control system is damaged, the walking belt may slow, accelerate, or stop unexpectedly, which may result in a fall and serious injury.
15. Keep the power cord and the surge suppressor away from heated surfaces.
16. Never move the walking belt while the power is turned off. Do not operate the treadmill if the power cord or plug is damaged, or if the treadmill is not working properly. (See MAINTENANCE AND TROUBLESHOOTING on page 26 if the treadmill is not working properly.)
17. Read, understand, and test the emergency stop procedure before using the treadmill (see HOW TO TURN ON THE POWER on page 18). Always wear the clip while using the treadmill.
18. Always stand on the foot rails when starting or stopping the walking belt. Always hold the handrails while using the treadmill.
19. When a person is walking on the treadmill, the noise level of the treadmill will increase.

20. Keep fingers, hair, and clothing away from the moving walking belt.
21. The treadmill is capable of high speeds. Adjust the speed in small increments to avoid sudden jumps in speed.
22. The heart rate monitor is not a medical device. Various factors, including the user's movement, may affect the accuracy of heart rate readings. The heart rate monitor is intended only as an exercise aid in determining heart rate trends in general.
23. Never leave the treadmill unattended while it is running. Always remove the key, press the power switch into the off position (see the drawing on page 5 for the location of the power switch), and unplug the power cord when the treadmill is not in use.
24. Do not attempt to move the treadmill until it is properly assembled. (See ASSEMBLY on page 7 and HOW TO FOLD AND MOVE THE TREADMILL on page 25.) You must be able to safely lift 45 lbs. (20 kg) to move the treadmill.
25. When folding or moving the treadmill, make sure that the storage latch is holding the frame securely in the storage position.
26. Do not change the incline of the treadmill by placing objects under the treadmill.
27. Never insert any object into any opening on the treadmill.
28. Inspect and properly tighten all parts of the treadmill regularly.
29. **DANGER:** Always unplug the power cord immediately after use, before cleaning the treadmill, and before performing the maintenance and adjustment procedures described in this manual. Never remove the motor hood unless instructed to do so by an authorized service representative. Servicing other than the procedures in this manual should be performed by an authorized service representative only.
30. Over exercising may result in serious injury or death. If you feel faint, if you become short of breath, or if you experience pain while exercising, stop immediately and cool down.

**SAVE THESE INSTRUCTIONS**

# BEFORE YOU BEGIN

Thank you for selecting the revolutionary PROFORM® POWER 995 C treadmill. The POWER 995 C treadmill offers an impressive selection of features designed to make your workouts at home more enjoyable and effective. And when you're not exercising, the unique treadmill can be folded up, requiring less than half the floor space of other treadmills.

**For your benefit, read this manual carefully before using the treadmill.** If you have questions after

reading this manual, please see the front cover of this manual. To help us assist you, please note the product model number and serial number before contacting us. The model number and the location of the serial number decal are shown on the front cover of this manual.

Before reading further, please review the drawing below and familiarize yourself with the labeled parts.

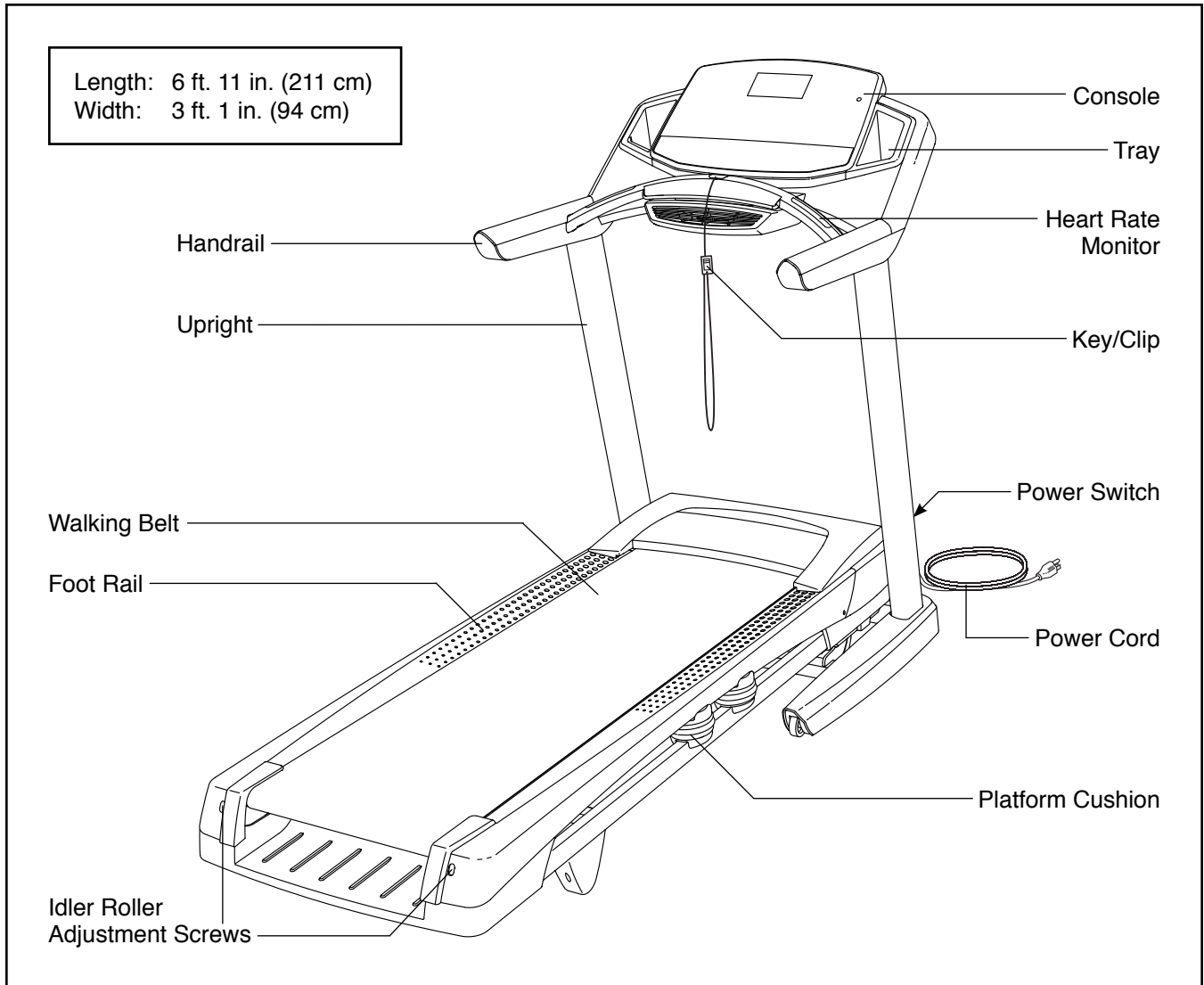



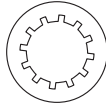
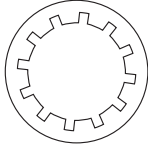
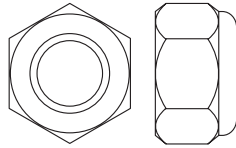
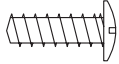
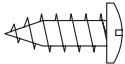
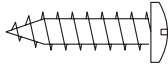
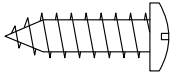
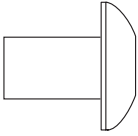
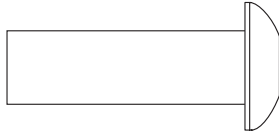
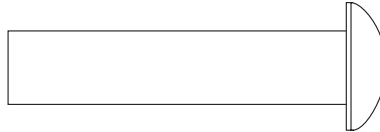
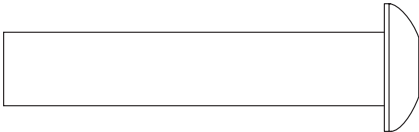
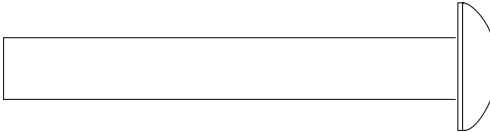
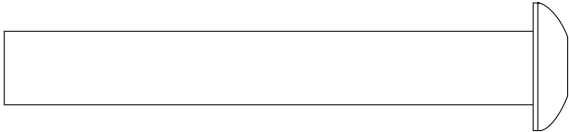

# PART IDENTIFICATION CHART

Use the drawings below to identify small parts used for assembly. The number in parentheses below each drawing is the key number of the part, from the PART LIST near the end of this manual. The number following the key number is the quantity used for assembly. **Note: If a part is not in the hardware kit, check to see whether it is preattached. Extra parts may be included.**

			
#10 Star Washer (14)—4	5/16" Star Washer (11)—8	3/8" Star Washer (13)—4	3/8" Nut (12)—2
			
#8 x 1/2" Ground Screw (9)—1	#8 x 1/2" Screw (1)—18	#8 x 3/4" Screw (2)—4	#10 x 3/4" Screw (7)—4
			
5/16" x 1/2" Screw (8)—4	3/8" x 1 1/4" Screw (6)—4	3/8" x 1 3/4" Bolt (4)—1	
			
3/8" x 2" Bolt (3)—1		5/16" x 2 1/2" Screw (10)—4	
			
3/8" x 2 3/4" Screw (5)—4			

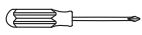
# ASSEMBLY

- To hire a service technician to assemble this product in your home, call 1-800-445-2480.
- Assembly requires two persons.
- Place all parts in a cleared area and remove the packing materials. Do not dispose of the packing materials until you finish all assembly steps.
- After shipping, there may be an oily substance on the exterior of the treadmill. This is normal. If there is an oily substance on the treadmill, wipe it off with a soft cloth and a mild, non-abrasive cleaner.
- Left parts are marked "L" or "Left" and right parts are marked "R" or "Right."
- To identify small parts, see page 6.
- Assembly requires the following tools:
  - the included hex keys 
  - an adjustable wrench 
  - one Phillips screwdriver 
  - scissors 

To avoid damaging parts, do not use power tools.

## 1. Make sure that the power cord is unplugged.

Attach the Left Wheel Cap (94) to the Base (95) with two #8 x 3/4" Screws (2).

**Attach the Right Wheel Cap (not shown) to the Base (95) in the same way.**

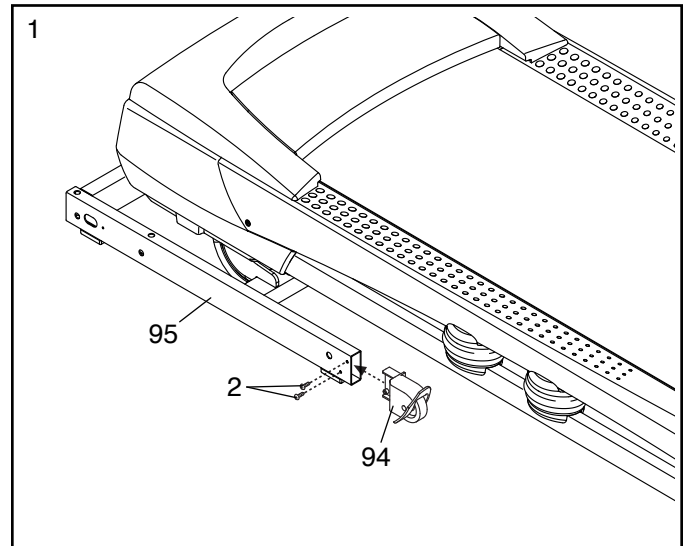

2. Pull the Upright Wire (78) and the base ground wire (A) through the indicated hole in the Base (95).

If there is a screw (B) pre-installed in the side of the Base (95), remove and discard it. Attach the ground wire (A) to the Base with a #8 x 1/2" Ground Screw (9).

Press the Grommet (90) into the square hole in the Base (95).

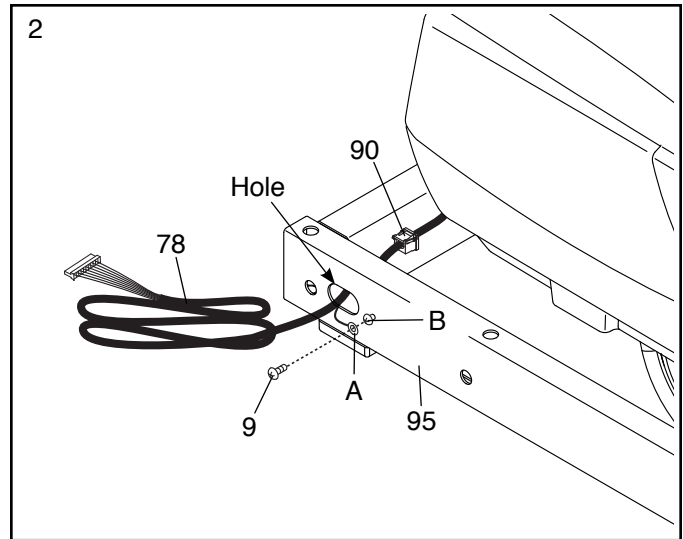

3. Identify the Left Upright (79). Have a second person hold the Left Upright near the Base (95).

**See the inset drawing.** Tie the wire tie in the Left Upright (79) securely around the end of the Upright Wire (78). Then, pull the other end of the wire tie until the Upright Wire is routed through the Left Upright.

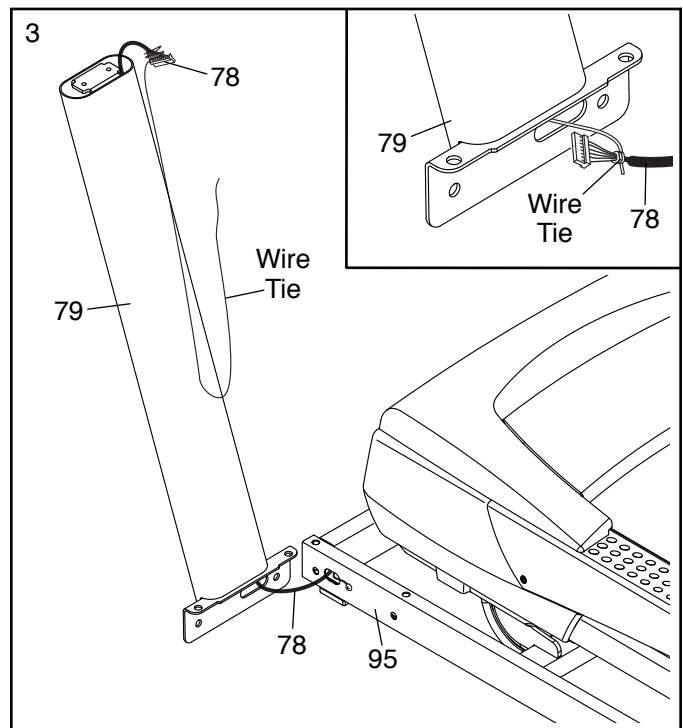

4. Hold the Left Upright (79) against the Base (95). **Be careful not to pinch the Upright Wire (78).** Insert two 3/8" x 1 1/4" Screws (6) with two 3/8" Star Washers (13) and two 3/8" x 2 3/4" Screws (5) into the Left Upright.

Partially tighten the 3/8" x 2 3/4" Screws (5) and the 3/8" x 1 1/4" Screws (6) until the heads of the Screws touch the Left Upright (79); **do not fully tighten the Screws yet.** Note: It may be helpful to use the short hex key on the Screw shown.

**Attach the Right Upright (not shown) in the same way.** Note: There are no wires on the right side.

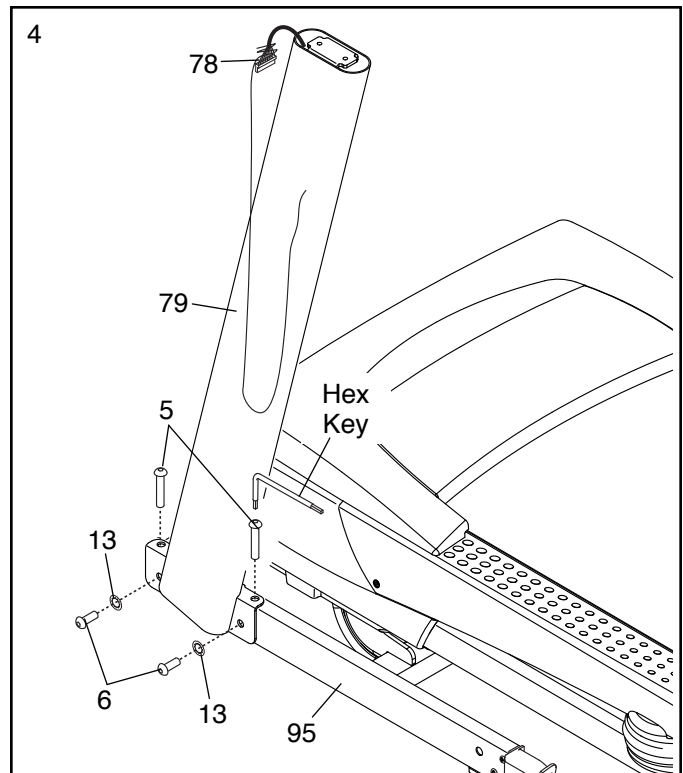

5. Identify the Left Base Cover (81) and the Right Base Cover (89). Slide the Left Base Cover onto the Left Upright (79). Slide the Right Base Cover onto the Right Upright (88). **Do not press the Base Covers into place yet.**

Identify the Left Bottom Handrail Cover (84) and the Right Bottom Handrail Cover (87). Slide the Left Bottom Handrail Cover onto the Left Upright (79). Slide the Right Bottom Handrail Cover onto the Right Upright (88).

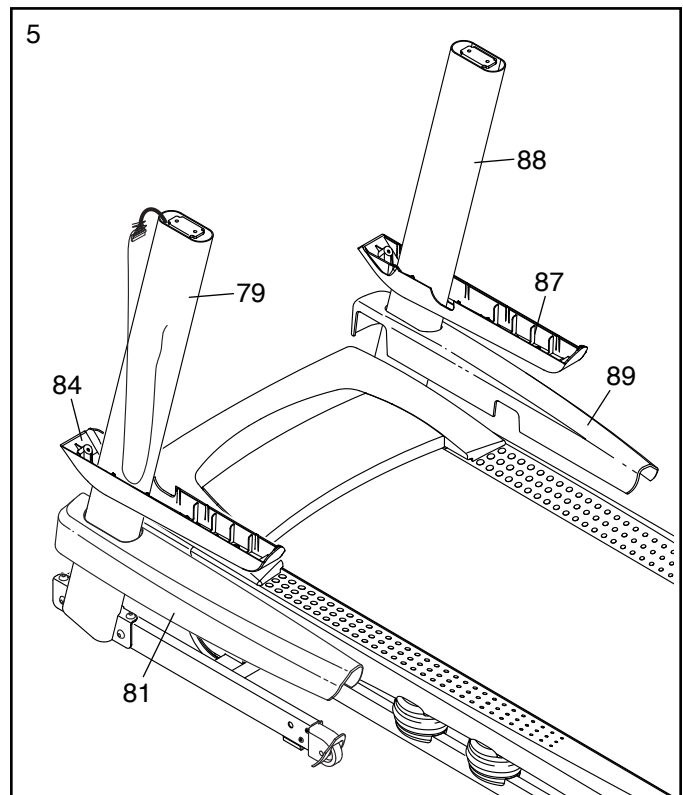

6. Attach the Left Handrail (83) to the Left Upright (79) with two 5/16" x 2 1/2" Screws (10) and two 5/16" Star Washers (11). **Make sure that the Upright Wire (78) is resting to the side as shown and is not pinched. Fully tighten the Screws.**

Attach the Right Handrail (86) with two 5/16" x 2 1/2" Screws (10) and two 5/16" Star Washers (11). **Fully tighten the Screws.**

Remove the wire tie from the Upright Wire (78).

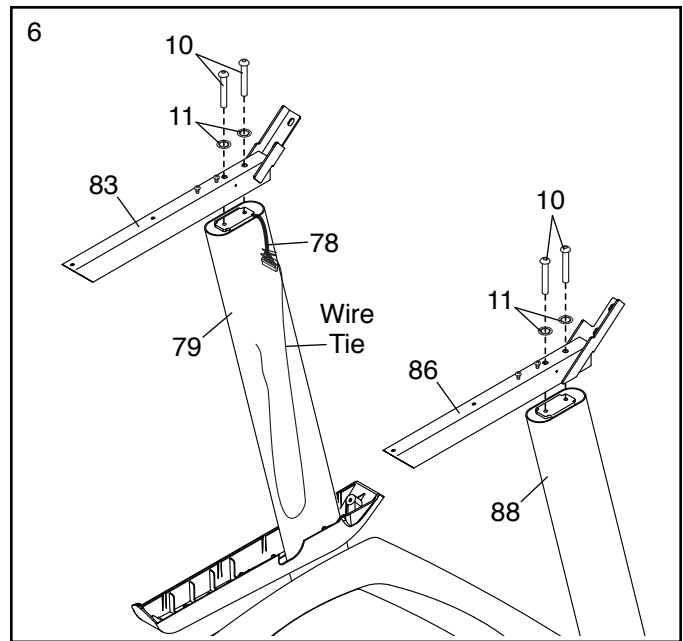

7. If there are four screws (C) in the locations shown, remove and discard them.

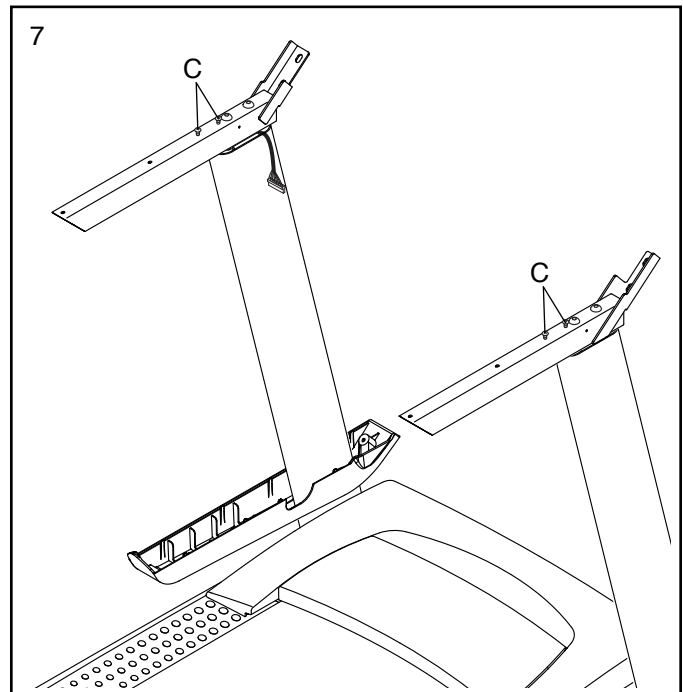

8. Set the console assembly face down on a soft surface to avoid scratching the console assembly. Remove and discard the three Screws (D). Next, lift off the Console Cover (100).

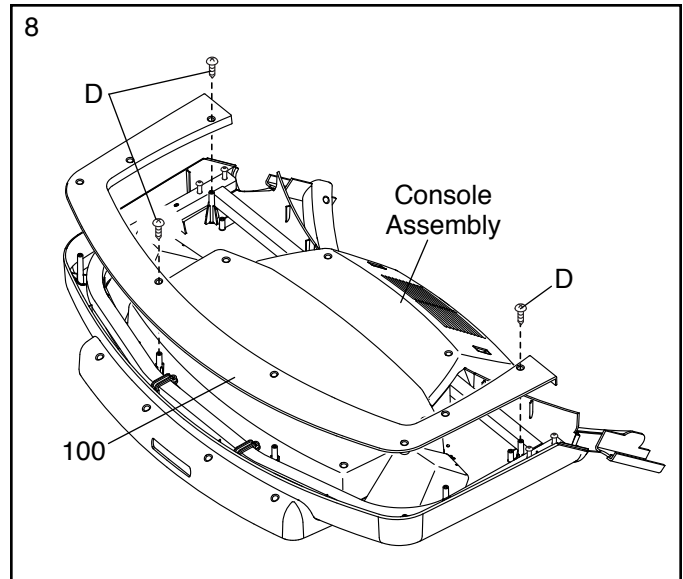

9. Set the console assembly on the Left Handrail (83) and the Right Handrail (86). **Make sure not to pinch any wires (E, 78).**

Attach the console assembly with four 5/16" x 1/2" Screws (8) and four 5/16" Star Washers (11). **Do not tighten the Screws yet.**

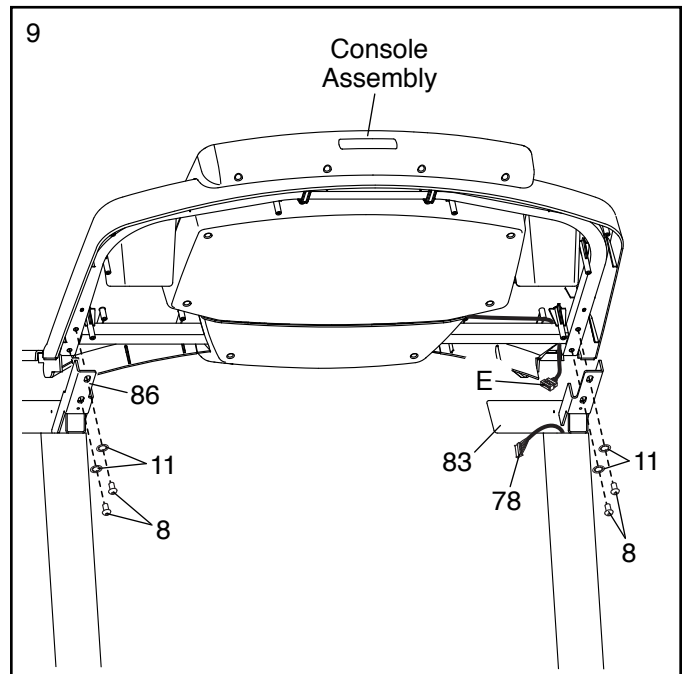

10. Attach the console assembly to the Handrails (83, 86) with four #10 x 3/4" Screws (7) and four #10 Star Washers (14) as shown. **Start all four Screws, and then tighten them.**

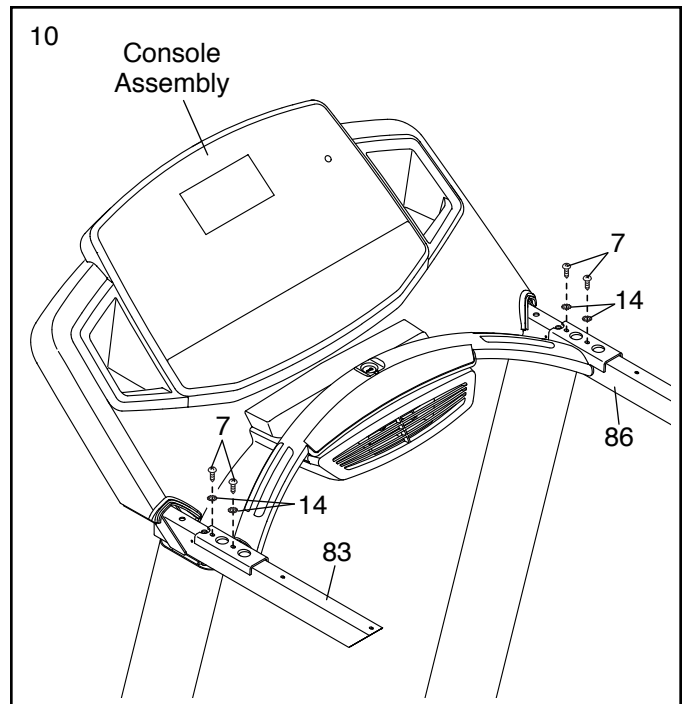

11. Connect the Upright Wire (78) to the console wire (E). **See the inset drawing. The connectors should slide together easily and snap into place.** If they do not, turn one connector and try again. **IF YOU DO NOT CONNECT THE CONNECTORS PROPERLY, THE CONSOLE MAY BECOME DAMAGED WHEN YOU TURN ON THE POWER.**

Insert the excess wires (E, 78) into the console assembly.

Firmly tighten the four 5/16" x 1/2" Screws (8) (only two are shown).

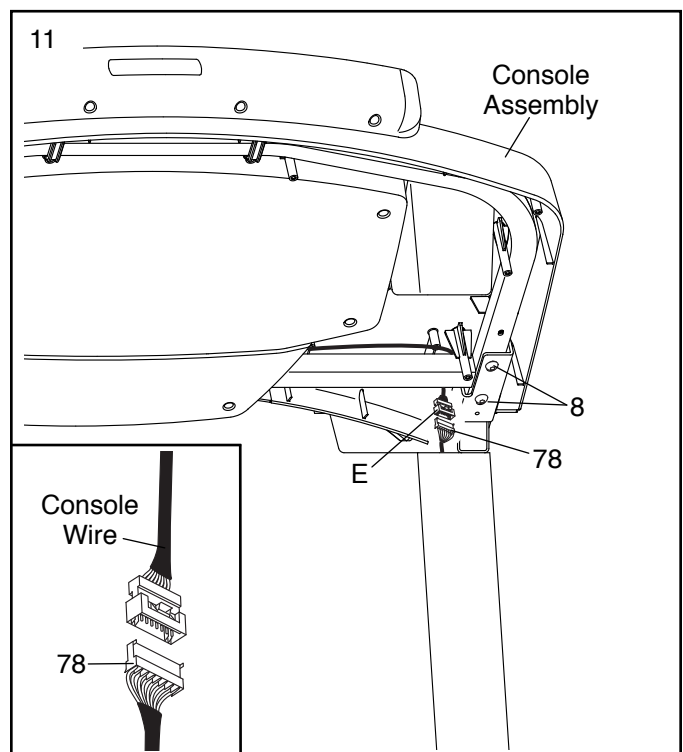

12. Attach the Left Handrail Cover (82) and the Right Handrail Cover (85) to the Handrails (83, 86) with three #8 x 1/2" Screws (1) each. **Do not overtighten the Screws.**

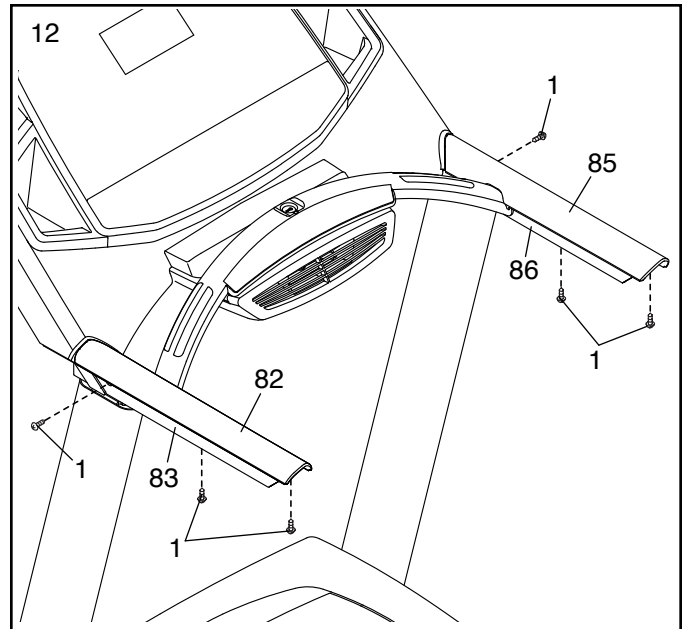

13. Slide the Left Bottom Handrail Cover (84) up against the Left Handrail Cover (82) and attach the Left Bottom Handrail Cover with two #8 x 1/2" Screws (1). **Do not overtighten the Screws.**

Attach the Right Bottom Handrail Cover (87) as described above.

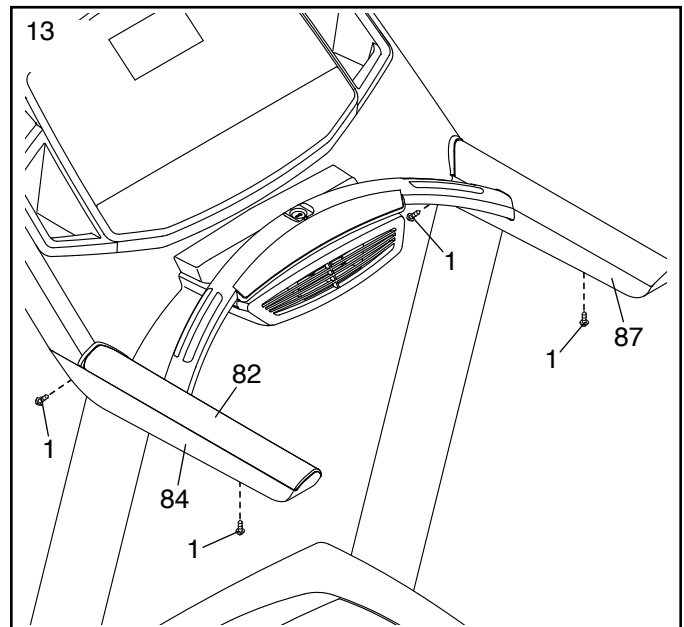

14. Attach the Console Cover (100) with eight #8 x 1/2" Screws (1). **Start all eight screws, and then tighten them. Do not overtighten the Screws. Make sure that no wires are pinched.**

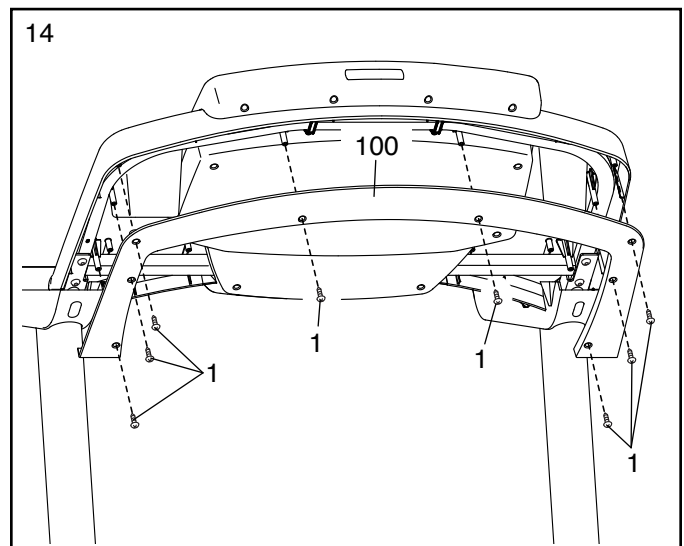

15. Firmly tighten the four 3/8" x 2 3/4" Screws (5) and then the four 3/8" x 1 1/4" Screws (6) (only one side is shown).

Press the Left Base Cover (81) and the Right Base Cover (89) onto the Base (95) until they snap into place.

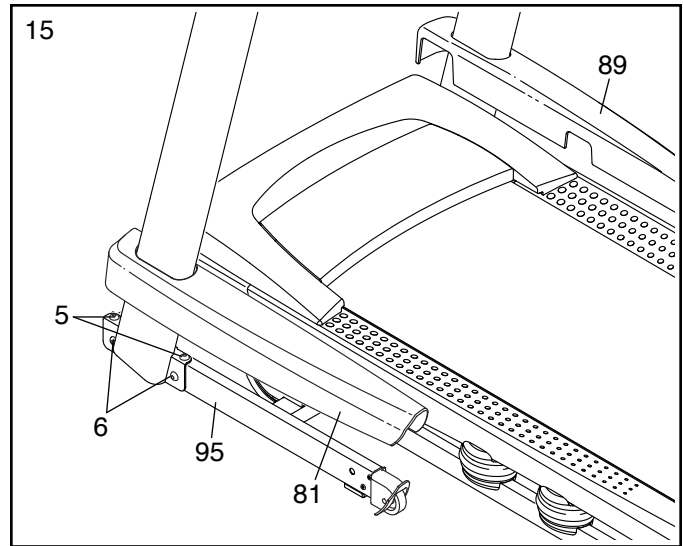

16. Raise the Frame (63) to the position shown. **Have a second person hold the Frame until this step is completed.**

Orient the Storage Latch (57) so that the large barrel and the latch knob are oriented as shown.

Attach the lower end of the Storage Latch (57) to the Base (95) with a 3/8" x 2" Bolt (3) and a 3/8" Nut (12).

Attach the upper end of the Storage Latch (57) to the bracket on the Frame (63) with a 3/8" x 1 3/4" Bolt (4) and a 3/8" Nut (12).

Lower the Frame (63) (see HOW TO LOWER THE TREADMILL FOR USE on page 25).

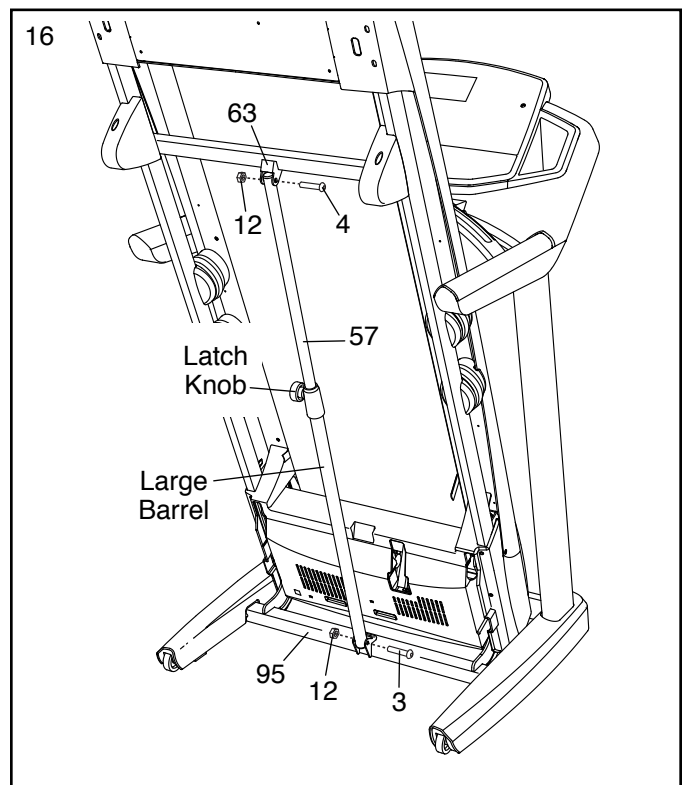

17. **Make sure that all parts are properly tightened before you use the treadmill.** If there are sheets of plastic on the treadmill decals, remove the plastic. To protect the floor or carpet, place a mat under the treadmill. Note: Extra parts may be included. Keep the included hex keys in a secure place; one of the hex keys is used to adjust the walking belt (see pages 27 and 28).

# THE CHEST HEART RATE MONITOR

## HOW TO PUT ON THE HEART RATE MONITOR

The heart rate monitor consists of a chest strap and a sensor. Insert the tab on one end of the chest strap into the hole in one end of the sensor as shown. Then, press the end of the sensor under the buckle on the chest strap. The tab should be flush with the front of the sensor.

The heart rate monitor must be worn under your clothes, tight against your skin. Wrap the heart rate monitor around your chest in the location shown. Make sure that the logo is right-side-up. Then, attach the other end of the chest strap to the sensor. Adjust the length of the chest strap, if necessary.

Pull the sensor away from your body a few inches and locate the two electrode areas, which are covered by shallow ridges. Using saline solution such as saliva or contact lens solution, wet the electrode areas. Then, return the sensor to a position against your chest.

## CARE AND MAINTENANCE

- Thoroughly dry the sensor with a soft towel after each use. Moisture may keep the sensor activated, shortening the life of the battery.
- Store the heart rate monitor in a warm, dry place. Do not store the heart rate monitor in a plastic bag or other container that may trap moisture.

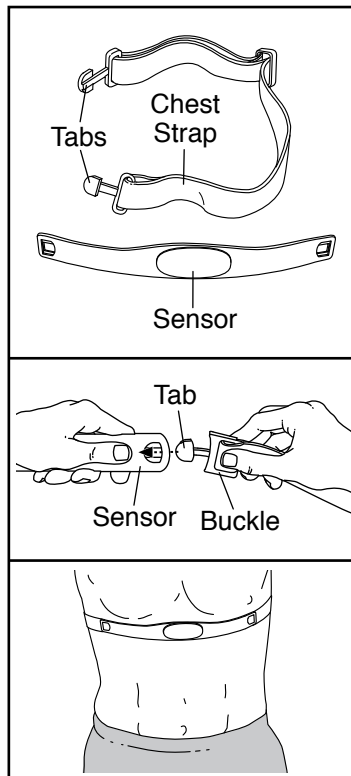

- Do not expose the heart rate monitor to direct sunlight for extended periods of time; do not expose it to temperatures above 122° F (50° C) or below 14° F (-10° C).
- Do not excessively bend or stretch the sensor when using or storing the heart rate monitor.
- To clean the sensor, use a damp cloth and a small amount of mild soap. Then, wipe the sensor with a damp cloth and thoroughly dry it with a soft towel. Never use alcohol, abrasives, or chemicals to clean the sensor. Hand wash and air dry the chest strap.

## TROUBLESHOOTING

If the heart rate monitor does not function properly, try the steps below.

- Make sure that you are wearing the heart rate monitor as described at the left. If the heart rate monitor does not function when positioned as described, move it slightly lower or higher on your chest.
- If heart rate readings are not displayed until you begin perspiring, rewet the electrode areas.
- For the console to display heart rate readings, you must be within arm's length of the console.
- If there is a battery cover on the back of the sensor, replace the battery with a new battery of the same type.
- The heart rate monitor is designed to work with people who have normal heart rhythms. Heart rate reading problems may be caused by medical conditions such as premature ventricular contractions (pvc's), tachycardia bursts, and arrhythmia.
- The operation of the heart rate monitor can be affected by magnetic interference from high power lines or other sources. If you suspect that magnetic interference is causing a problem, try relocating the fitness equipment.

# HOW TO USE THE TREADMILL

## HOW TO CONNECT THE POWER CORD

### Use a Surge Suppressor

Your treadmill, like other electronic equipment, can be damaged by sudden voltage changes in your home's power. Voltage surges, spikes, and noise interference can result from weather conditions or from other appliances being turned on or off. **To decrease the risk of damaging the treadmill, always use a surge suppressor with the treadmill. To purchase a surge suppressor, see precaution 13 on page 3.**

Use only a surge suppressor that is UL 1449 listed as a transient voltage surge suppressor (TVSS). The surge suppressor must have a UL suppressed voltage rating of 400 volts or less and a minimum surge dissipation of 450 joules. The surge suppressor must also be electrically rated for 120 volts AC and 15 amps. There must be a monitoring light on the surge suppressor to indicate whether it is functioning properly. **Failure to use a properly functioning surge suppressor could result in damage to the control system of the treadmill and serious injury to users.**

### Plug in the Power Cord

**The treadmill must be grounded.** If it should malfunction or break down, grounding provides a path of least resistance for electric current to reduce the risk of electric shock. The treadmill power cord has a plug with a grounding pin (see drawing 1 on this page).

**⚠ DANGER:** Improper connection of the power cord increases the risk of electric shock. Do not modify the plug—if it will not fit an outlet, have a proper outlet installed by a qualified electrician. If you are unsure whether the treadmill is properly grounded, contact a qualified electrician.

Plug the power cord into a surge suppressor, and plug the surge suppressor into an appropriate outlet that is properly installed and grounded in accordance with all local codes and ordinances. **The outlet must be on a**

nominal 120-volt circuit capable of carrying 15 or more amps. To avoid overloading the circuit, do not plug other electrical devices, except for low-power devices such as cell phone chargers, into the surge suppressor or into an outlet on the same circuit. **IMPORTANT: The treadmill may not be compatible with AFCI-equipped outlets.**

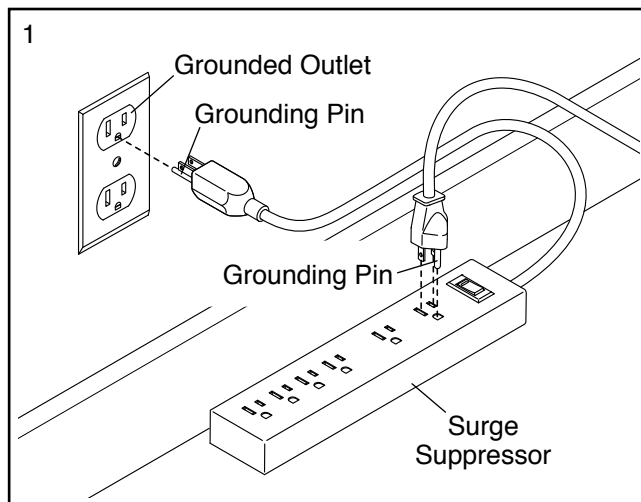

A temporary adapter may be used to connect the surge suppressor to a 2-pole receptacle if a properly grounded outlet is not available.

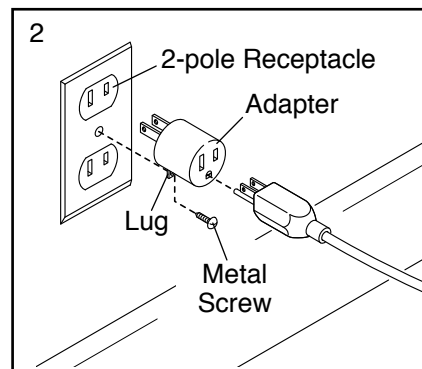

The lug or wire extending from the adapter must be connected with a metal screw to a permanent ground such as a properly grounded outlet box cover. **Some 2-pole receptacle outlet box covers are not grounded. Before using an adapter, contact a qualified electrician to determine whether the outlet box cover is grounded. The temporary adapter should be used only until a properly grounded outlet can be installed by a qualified electrician.**

## CONSOLE DIAGRAM

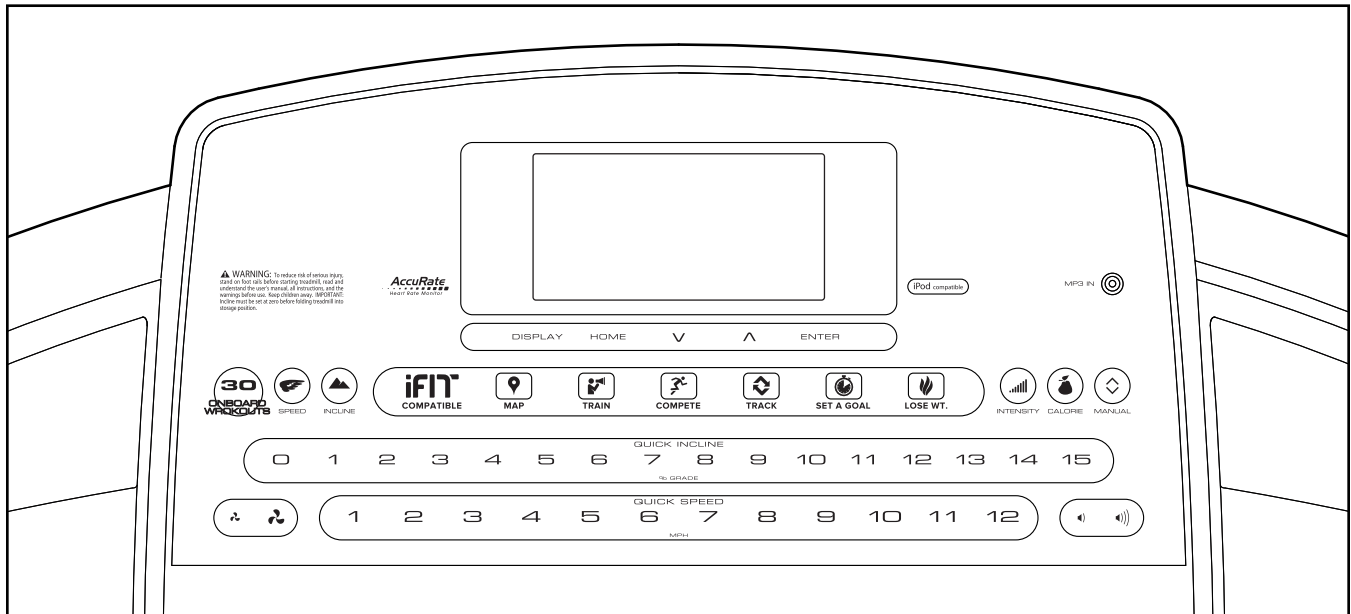

### FEATURES OF THE CONSOLE

The treadmill console offers an impressive array of features designed to make your workouts more effective and enjoyable. When you use the manual mode, you can change the speed and incline of the treadmill with the touch of a button. As you exercise, the console will display instant exercise feedback. You can even measure your heart rate using the handgrip heart rate monitor or the chest heart rate monitor.

In addition, the console features thirty onboard workouts—eight speed workouts, seven incline workouts, seven intensity workouts, and eight calorie workouts. Each workout automatically controls the speed and incline of the treadmill as it guides you through an effective exercise session.

The console also features an iFit mode that enables the treadmill to communicate with your wireless network through an optional iFit module. With the iFit mode, you can download personalized workouts, create your own workouts, track your workout results, race against other iFit users, and access many other features. **To purchase an iFit module at any time, go to [www.iFit.com](http://www.iFit.com) or call the telephone number on the front cover of this manual.**

You can even listen to your favorite workout music or audio books with the console's stereo sound system while you exercise. This treadmill has been designed specifically to work with iPod and has been certified by the developer to meet Apple performance standards.

**To turn on the power**, see page 18. **To use the manual mode**, see page 18. **To use an onboard workout**, see page 21. **To use a set-a-goal workout**, see page 22. **To use an iFit workout**, see page 22. **To use the stereo sound system**, see page 23. **To use the information mode**, see page 24.

**IMPORTANT:** If there are sheets of plastic on the console, remove the plastic. To prevent damage to the walking platform, wear clean athletic shoes while using the treadmill. The first time you use the treadmill, observe the alignment of the walking belt, and center the walking belt if necessary (see page 28).

## HOW TO TURN ON THE POWER

**IMPORTANT:** If the treadmill has been exposed to cold temperatures, allow it to warm to room temperature before you turn on the power. If you do not do this, you may damage the console displays or other electrical components.

Plug in the power cord (see page 16). Next, locate the power switch on the treadmill frame near the power cord. Press the power switch into the reset position.

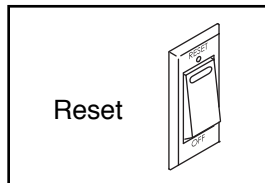

**IMPORTANT:** The console features a display demo mode, designed to be used if the treadmill is displayed in a store. If the displays light as soon as you plug in the power cord and press the power switch into the reset position, the demo mode is turned on. To turn off the demo mode, hold down the Stop button for a few seconds. If the displays remain lit, see THE INFORMATION MODE on page 24 to turn off the demo mode.

Next, stand on the foot rails of the treadmill. Find the clip attached to the key and slide the clip onto the waistband of your clothes. Then, insert the key into the console. After a moment, the displays will light.

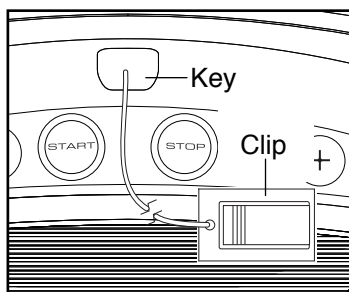

**IMPORTANT:** In an emergency, the key can be pulled from the console, causing the walking belt to slow to a stop. Test the clip by carefully taking a few steps backward; if the key is not pulled from the console, adjust the position of the clip.

## HOW TO USE THE MANUAL MODE

### 1. Insert the key into the console.

See HOW TO TURN ON THE POWER at the left.

### 2. Select the manual mode.

Press the Manual button on the console. If you are not connected to iFit, the manual mode will be selected automatically.

### 3. Start the walking belt.

To start the walking belt, press the Start button, the Speed increase button, or one of the numbered Quick Speed buttons.

If you press the Start button or the Speed increase button, the walking belt will begin to move at 1 mph. As you exercise, change the speed of the walking belt as desired by pressing the Speed increase and decrease buttons. Each time you press one of the buttons, the speed setting will change by 0.1 mph; if you hold down the button, the speed setting will change in increments of 0.5 mph. Note: After you press the button, it may take a moment for the walking belt to reach the selected speed setting.

If you press one of the numbered Quick Speed buttons, the walking belt will gradually change speed until it reaches the selected speed setting. To select a speed setting that includes a decimal—such as 3.5 mph—press two numbered buttons in succession. For example, to select a speed setting of 3.5 mph, press the 3 button and then immediately press the 5 button. Note: This will not function if the console is set to metric units.

To stop the walking belt, press the Stop button. The time will begin to flash in the display. To restart the walking belt, press the Start button or the Speed increase button.

**4. Change the incline of the treadmill as desired.**

To change the incline of the treadmill, press the Incline increase or decrease button or one of the numbered Quick Incline buttons. Each time you press one of the buttons, the treadmill will gradually adjust to the selected incline setting.

**5. Follow your progress with the displays.**

**The matrix**—When you select the manual mode, the matrix will display a track that represents 1/4 mile (400 m). As you exercise, the indicators around the track will appear in succession until the entire track appears. The track will then disappear and the indicators will again begin to appear in succession.



**The Calories/Incline display**—This display will show the approximate number of calories you have burned.

The display will also show the incline of the treadmill for a few seconds each time the incline of the treadmill changes.

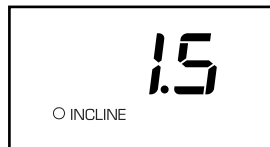

**The Time display**—

This display will show the elapsed time. Note: When an onboard workout is selected, the display will show the time remaining in the workout instead of the elapsed time.



**The Distance display**—This display will show the distance that you have walked or run.



**The Speed/Pulse display**—This display will show the speed of the walking belt. The display will also show your heart rate when you use the handgrip heart rate monitor or the chest heart rate monitor (see step 6 on page 20).



**The Center display**—This display will show workout instructions.

Press the Home button to return to the start mode (see THE INFORMATION MODE on page 24 to set the start mode). If necessary, press the Home button again.

When an iFit module is connected to [www.iFit.com](http://www.iFit.com), the iFit symbol near the top of the display will light.



To reset the displays, press the Stop button, remove the key, and then reinsert the key.

6. Measure your heart rate if desired.

**Note:** If you use the handgrip heart rate monitor and the chest heart rate monitor at the same time, the console will not display your heart rate accurately. For information about the chest heart rate monitor, see page 15.

Before using the handgrip heart rate monitor, remove the sheets of plastic from the metal contacts on the pulse bar. In addition, make sure that your hands are clean.

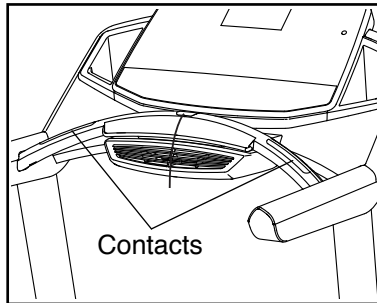

To measure your heart rate, **stand on the foot rails** and hold the pulse bar with your palms on the metal contacts; **avoid moving your hands**. When your pulse is detected, several dashes will appear and then your heart rate will be shown. **For the most accurate heart rate reading, continue to hold the contacts for about 15 seconds.**

7. Turn on the fan if desired.

The fan features multiple speed settings. Press the fan increase or decrease button to select a fan speed or to turn off the fan. Note: If the fan is on when the walking belt is stopped, the fan will turn off automatically after a few minutes.



8. When you are finished exercising, remove the key from the console.

Step onto the foot rails, press the Stop button, and **adjust the incline of the treadmill to the lowest setting. The incline must be at the lowest setting or you may damage the treadmill when you fold it to the storage position.** Next, remove the key from the console and put it in a secure place.

When you are finished using the treadmill, press the power switch into the off position and unplug the power cord. **IMPORTANT: If you do not do this, the treadmill's electrical components may wear prematurely.**

## HOW TO USE AN ONBOARD WORKOUT

### 1. Insert the key into the console.

See HOW TO TURN ON THE POWER on page 18.

### 2. Select an onboard workout.

To select an onboard workout, press the Speed button, the Incline button, the Intensity button, or the Calorie button repeatedly until the desired workout appears in the display.

When you select an onboard workout, the displays will show the maximum incline, the duration, the distance, the maximum speed, and the name of the workout. In addition, a profile of the speed settings of the workout will appear in the matrix. If you select a calorie workout, the approximate number of calories you will burn will appear in the name of the workout.

### 3. Start the workout.

Press the Start button or the Speed increase button to start the workout. A moment after you press the button, the treadmill will automatically adjust to the first speed and incline settings of the workout. Hold the handrails and begin walking.

Each workout is divided into segments. One speed setting and one incline setting are programmed for each segment. Note: The same speed setting and/or incline setting may be programmed for consecutive segments.

During the workout, the profile will show your progress. The flashing segment of the profile represents the current segment of the workout. The height of the flashing segment indicates the speed setting for the current segment. At the end of each segment, a series of tones will sound and the next segment of the profile will begin to flash. If a new speed and/or incline setting is programmed for the next segment, the new speed and/or incline setting will appear in the displays for a few seconds and the treadmill will automatically adjust to the new speed and/or incline setting.



The workout will continue in this way until the last segment of the profile flashes in the display and the last segment ends. The walking belt will then slow to a stop.

**Note: The calorie goal is an estimate of the number of calories that you will burn during the workout. The actual number of calories that you burn will depend on various factors such as your weight. In addition, if you manually change the speed or incline of the treadmill during the workout, the number of calories you burn will be affected.**

If the speed or incline setting is too high or too low at any time during the workout, you can manually override the setting by pressing the Speed or Incline buttons; **however, when the next segment of the workout begins, the treadmill will automatically adjust to the speed and incline settings for the next segment.**

To stop the workout at any time, press the Stop button. The time will begin to flash in the display. To resume the workout, press the Start button or the Speed increase button. The walking belt will begin to move at 1 mph. When the next segment of the workout begins, the treadmill will automatically adjust to the speed and incline settings for the next segment.

### 4. Follow your progress with the displays.

See step 5 on page 19.

### 5. Measure your heart rate if desired.

See step 6 on page 20.

### 6. Turn on the fan if desired.

See step 7 on page 20.

### 7. When you are finished exercising, remove the key from the console.

See step 8 on page 20.

## HOW TO USE A SET-A-GOAL WORKOUT

### 1. Insert the key into the console.

See HOW TO TURN ON THE POWER on page 18.

### 2. Select a set-a-goal workout.

To select a set-a-goal workout, press the Set A Goal button on the console.

Use the increase and decrease buttons next to the Enter button to set a calorie, time, or distance goal, and then press the Enter button. Next, press the increase and decrease buttons next to the Enter button to select a goal. Press the Speed and Incline buttons to select the speed and incline for the workout. The screen will show the duration and distance of the workout, and the approximate number of calories you will burn during the workout.

### 3. Start the workout.

Press the Start button to start the workout. A moment after you press the button, the walking belt will begin to move. Hold the handrails and begin walking.

The workout will function in the same way as the manual mode (see pages 18 to 20).

The workout will continue until you reach the goal that you set. The walking belt will then slow to a stop.

**Note: The calorie goal is an estimate of the number of calories that you will burn during the workout. The actual number of calories that you burn will depend on various factors such as your weight.**

### 4. Follow your progress with the displays.

See step 5 on page 19.

### 5. Measure your heart rate if desired.

See step 6 on page 20.

### 6. Turn on the fan if desired.

See step 7 on page 20.

### 7. When you are finished exercising, remove the key from the console.

See step 8 on page 20.

## HOW TO USE AN IFIT WORKOUT

Note: To use an iFit workout, you must have an optional iFit module. **To purchase an iFit module at any time, go to [www.iFit.com](http://www.iFit.com) or call the telephone number on the front cover of this manual.** You must also have access to a computer with a USB port and an internet connection. In addition, you must have access to a wireless network including an 802.11b router with SSID broadcast enabled (hidden networks are not supported). An iFit.com membership is also required.

### 1. Insert the key into the console.

See HOW TO TURN ON THE POWER on page 18.

### 2. Insert the iFit module into the console.

To insert the iFit module, see the instructions included with the iFit module.

**IMPORTANT: To satisfy exposure compliance requirements, the antenna and transmitter in the iFit module must be at least 8 in. (20 cm) from all persons and must not be near or connected to any other antenna or transmitter.**

### 3. Select a user.

If more than one user is registered, you can switch users in the iFit main screen. Press the increase and decrease buttons next to the Enter button to select a user.

### 4. Select an iFit workout.

To select an iFit workout, press one of the iFit buttons. Before some workouts will download, you must add them to your schedule on [www.iFit.com](http://www.iFit.com).

To download an iFit workout in your schedule, press the Map, Train, or Lose Wt. button to download the next workout of that type in your schedule. To compete in a race that you have previously scheduled, press the Compete button.

To re-run a recent iFit workout from your schedule, first press the Track button. Next, press the increase and decrease buttons to select the desired workout. Then, press the Enter button to start the workout.

Note: Before some workouts will download, you must add them to your schedule on iFit.com.

**For more information about the iFit workouts, please see [www.iFit.com](http://www.iFit.com).**

When you select an iFit workout, the display will show the duration of the workout, the distance you will walk or run, and the approximate number of calories you will burn. The display may also show the name of the workout. If you select a competition workout, the display will count down to the beginning of the race.

Note: Each iFit button can also run two demo workouts. To use the demo workouts, remove the iFit module from the console and press one of the iFit buttons.

#### 5. Start the workout.

See step 3 on page 21.

During some workouts, the voice of an audio coach will guide you through your workout. You can select a setting for your audio coach (see THE INFORMATION MODE on page 24).

To stop the workout at any time, press the Stop button. The time will begin to flash in the display. To resume the workout, press the Start button or the Speed increase button. The walking belt will begin to move at the speed setting for the first segment of the workout. When the next segment of the workout begins, the treadmill will automatically adjust to the speed and incline settings for the next segment.

#### 6. Follow your progress with the displays.

See step 5 on page 19.

During a competition workout, the Compete tab will show your progress in the race. As you race, the top line in the matrix will show how much of the

race you have completed. The other lines will show your top four competitors. The end of the matrix represents the end of the race.

#### 7. Measure your heart rate if desired.

See step 6 on page 20.

#### 8. Turn on the fan if desired.

See step 7 on page 20.

#### 9. When you are finished exercising, remove the key from the console.

See step 8 on page 20.

**For more information about the iFit mode, go to [www.iFit.com](http://www.iFit.com).**

### HOW TO USE THE STEREO SOUND SYSTEM

To play music or audio books through the console's stereo speakers, you must connect your MP3 player, CD player, or other personal audio player to the console through the audio jack.

To use the MP3 jack, plug your audio cable into the MP3 jack on the top of the console. Then plug your audio cable into a jack on your MP3 player, CD player, or other personal audio player. **Make sure that your audio cable is fully plugged in.**

Next, press the play button on your MP3 player, CD player, or other personal audio player. Adjust the volume on your personal audio player or press the volume increase and decrease buttons on the console.

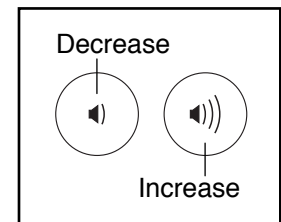

If you are using a personal CD player and the CD skips, set the CD player on the floor or another flat surface and not on the console.

## THE INFORMATION MODE

The console features an information mode that keeps track of treadmill information and allows you to personalize console settings.

### 1. Select the information mode.

To select the information mode, hold down the Stop button while inserting the key into the console and then release the Stop button. When the information mode is selected, the following information will be shown:

The Time display will show the total number of hours the treadmill has been used.



The Distance display will show the total number of miles or kilometers that the walking belt has moved.

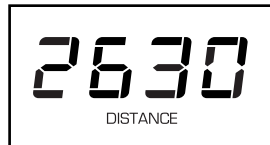

### 2. Select the optional screens.

While the information mode is selected, the matrix will display several optional screens. Press the decrease button next to the Enter button to select each of the following screens:

**UNITS**—To change the unit of measurement, press the Enter button. To view distance in miles, select ENGLISH. To view distance in kilometers, select METRIC.

**DEMO**—The console features a display demo mode, designed to be used if the treadmill is displayed in a store. While the demo mode is turned on, the console will function normally when you plug in the power cord, press the power switch into the reset position, and insert the key into the console. However, when you remove the key, the

displays will remain lit, although the buttons will not function. If the demo mode is turned on, the word ON will appear in the center display. To turn on or turn off the demo mode, press the Enter button or the Speed decrease button.

**CONTRAST LVL**—Press the Incline increase and decrease buttons to adjust the contrast level of the displays. Then, press the Enter button.

If a module is connected, you may also select the following screens:

**MODULE**—If an iFit module is connected, the display will show the word WIFI. If a USB module is connected, the display will show the word USB/SD.

**AUDIO COACH**—To turn on or turn off the audio coach, press the Enter button.

If an iFit module is connected, you may also select the following screens:

**START MODE**—The start mode will appear when you insert the key into the console or when you press the Home button. Press the Enter button repeatedly to select the manual mode or the iFit mode as the start mode.

**CHECK WIFI**—Press the Enter button. The center display will show the software version number, the network SSID, the network encryption type, the wireless signal strength, the IP address of the module, the number of registered users and their names, and the results of the DNS lookup.

**SEND/OBTAIN DATA**—To send and receive workouts, workout logs, and updates, press the Enter button. When the process is finished, the words TRANSFERS DONE will appear in the display.

### 3. Exit the information mode.

To exit the information mode, remove the key from the console.

# HOW TO FOLD AND MOVE THE TREADMILL

## HOW TO FOLD THE TREADMILL

To avoid damaging the treadmill, adjust the incline to the lowest position before you fold the treadmill. Then, remove the key and unplug the power cord. **CAUTION:** You must be able to safely lift 45 lbs. (20 kg) to raise, lower, or move the treadmill.

1. Hold the metal frame firmly in the location shown by the arrow below. **CAUTION:** Do not hold the frame by the plastic foot rails. Bend your legs and keep your back straight.

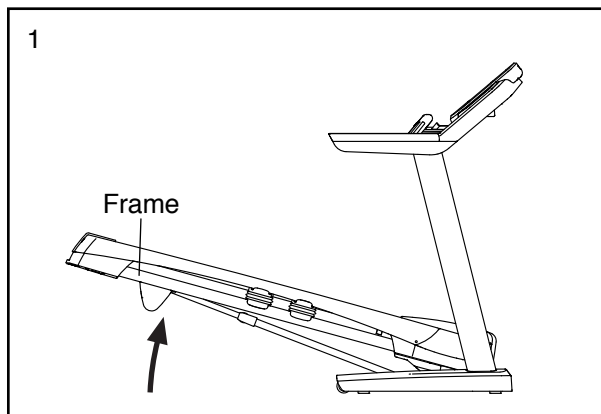

2. Raise the frame until the latch knob locks in the storage position. **CAUTION:** Make sure that the latch knob locks.

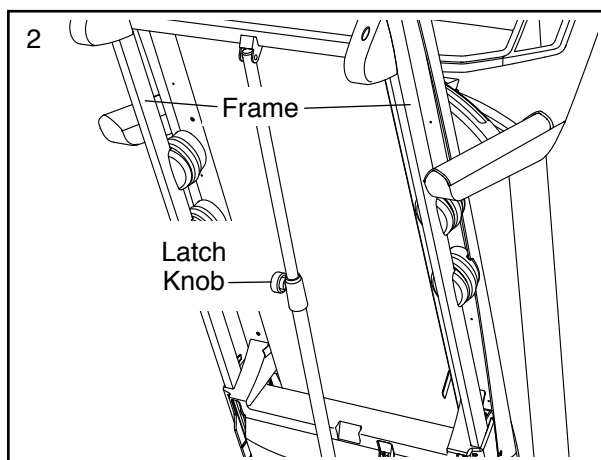

To protect the floor or carpet, place a mat under the treadmill. Keep the treadmill out of direct sunlight. Do not leave the treadmill in the storage position in temperatures above 85° F (30° C).

## HOW TO MOVE THE TREADMILL

Before moving the treadmill, fold it as described at the left. **CAUTION:** Make sure that the latch knob is locked in the storage position. Moving the treadmill may require two people.

1. Hold the frame and one of the handrails, and place one foot against a wheel.

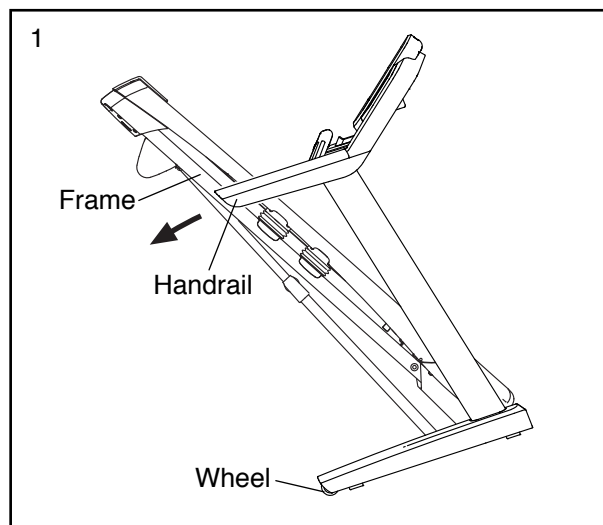

2. Pull back on the handrail until the treadmill will roll on the wheels, and carefully move it to the desired location. **CAUTION:** Do not move the treadmill without tipping it back, do not pull on the frame, and do not move the treadmill over an uneven surface.
3. Place one foot against a wheel, and carefully lower the treadmill.

## HOW TO LOWER THE TREADMILL FOR USE

1. **See drawing 2.** Hold the upper end of the treadmill frame with your right hand. Then, pull the latch knob to the left. **IMPORTANT:** Do not turn the latch knob. If necessary, push the frame forward slightly. Pivot the frame downward a few inches, and release the latch knob.
2. **See drawing 1 at the left.** Hold the metal frame firmly with both hands, and lower it to the floor. **CAUTION:** Do not hold the frame by the plastic foot rails, and do not drop the frame. Bend your legs and keep your back straight.

# MAINTENANCE AND TROUBLESHOOTING

## MAINTENANCE

Regularly clean the treadmill and keep the walking belt clean and dry. First, **press the power switch into the off position and unplug the power cord**. Wipe exterior parts of the treadmill with a damp cloth and a small amount of mild soap. **IMPORTANT: Do not spray liquids directly onto the treadmill. To avoid damage to the console, keep liquids away from the console.** Then, thoroughly dry the treadmill with a soft towel.

## TROUBLESHOOTING

**Most treadmill problems can be solved by following the simple steps below. Find the symptom that applies, and follow the steps listed. If further assistance is needed, see the front cover of this manual.**

### SYMPTOM: The power does not turn on

- Make sure that the power cord is plugged into a surge suppressor, and that the surge suppressor is plugged into a properly grounded outlet (see page 16). Use only a surge suppressor that meets all of the specifications described on page 16. **IMPORTANT: The treadmill may not be compatible with AFCI-equipped outlets.**
- After the power cord has been plugged in, make sure that the key is inserted into the console.
- Check the power switch located on the treadmill frame near the power cord. If the switch protrudes as shown, the switch has tripped. To reset the power switch, wait for five minutes and then press the switch back in.

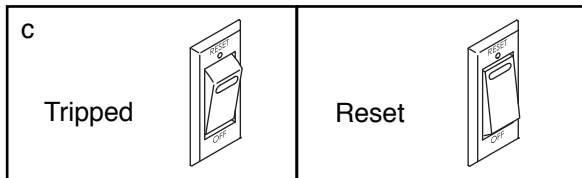

### SYMPTOM: The power turns off during use

- Check the power switch (see drawing c at the left). If the switch has tripped, wait for five minutes and then press the switch back in.
- Make sure that the power cord is plugged in. If the power cord is plugged in, unplug it, wait for five minutes, and then plug it back in.
- Remove the key from the console, and then reinsert it.
- If the treadmill still will not run, please see the front cover of this manual.

### SYMPTOM: The console displays remain lit when you remove the key from the console

- The console features a display demo mode, designed to be used if the treadmill is displayed in a store. If the displays remain lit when you remove the key, the demo mode is turned on. To turn off the demo mode, hold down the Stop button for a few seconds. If the displays are still lit, see THE INFORMATION MODE on page 24 to turn off the demo mode.

### SYMPTOM: The displays of the console do not function properly

- Remove the key from the console and **UNPLUG THE POWER CORD**. Remove the seven #8 x 3/4" Truss Head Screws (16). Carefully pivot off the Motor Hood (64).

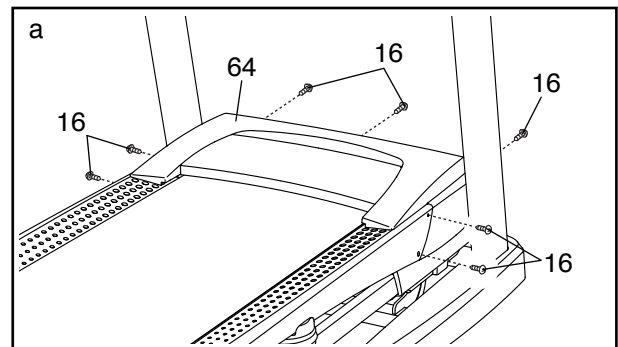

Locate the Reed Switch (52) and the Magnet (53) on the left side of the Pulley (54). Turn the Pulley until the Magnet is aligned with the Reed Switch. **Make sure that the gap between the Magnet and the Reed Switch is about 1/8 in. (3 mm).** If necessary, loosen the #8 x 3/4" Tek Screw (15), move the Reed Switch slightly, and then retighten the Screw. Reattach the Motor Hood (not shown) and run the treadmill for a few minutes to check for a correct speed reading.

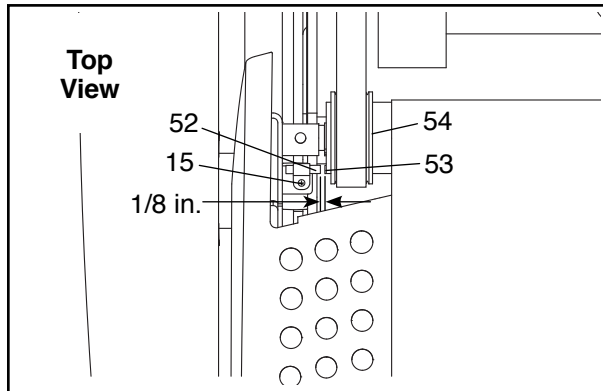

**SYMPTOM: The incline of the treadmill does not change correctly**

- a. Hold down the Stop button and the Speed increase button, insert the key into the console, and then release the Stop button and the Speed increase button. Press the Stop button and then press the Incline increase or decrease button. The treadmill will automatically rise to the maximum incline level and then return to the minimum level. This will recalibrate the incline system. If the incline does not begin calibrating, press the Stop button again, and then press the Incline increase or decrease button again. When the incline is calibrated, remove the key from the console.

**SYMPTOM: The walking belt slows when walked on**

- a. Use only a surge suppressor that meets all of the specifications described on page 16.

- b. If the walking belt is overtightened, treadmill performance may decrease and the walking belt may become damaged. Remove the key and **UNPLUG THE POWER CORD**. Using the hex key, turn both idler roller screws counterclockwise, 1/4 of a turn. When the walking belt is properly tightened, you should be able to lift each edge of the walking belt 2 to 3 in. (5 to 7 cm) off the walking platform. Be careful to keep the walking belt centered. Then, plug in the power cord, insert the key, and run the treadmill for a few minutes. Repeat until the walking belt is properly tightened.

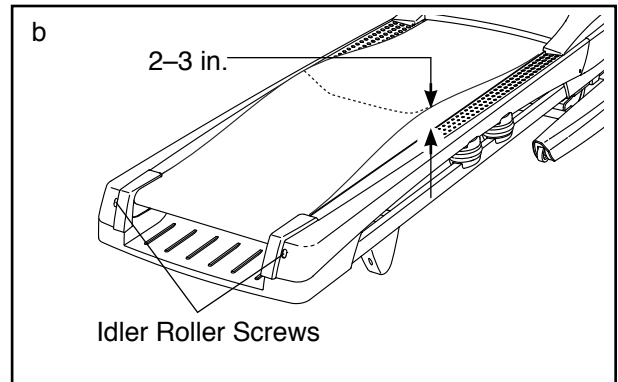

- c. Your treadmill features a walking belt coated with high-performance lubricant. **IMPORTANT: Never apply silicone spray or other substances to the walking belt or the walking platform unless instructed to do so by an authorized service representative. Such substances may deteriorate the walking belt and cause excessive wear.** If you suspect the walking belt needs more lubricant, see the front cover of this manual.
- d. If the walking belt still slows when walked on, see the front cover of this manual.

**SYMPTOM: The walking belt is off-center or slips when walked on**

- a. **If the walking belt is off-center**, first remove the key and **UNPLUG THE POWER CORD**. **If the walking belt has shifted to the left**, use the hex key to turn the left idler roller screw clockwise 1/2 of a turn; **if the walking belt has shifted to the right**, turn the left idler roller screw counterclockwise 1/2 of a turn. Be careful not to overtighten the walking belt. Then, plug in the power cord, insert the key, and run the treadmill for a few minutes. Repeat until the walking belt is centered.

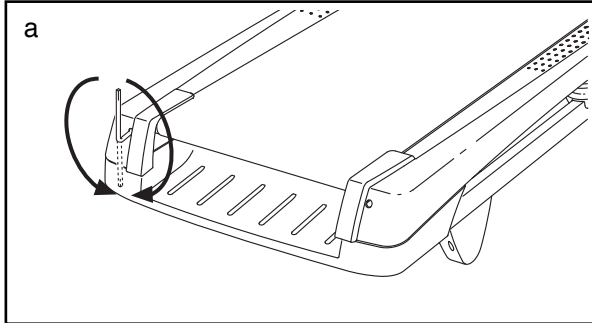

- b. **If the walking belt slips when walked on**, first remove the key and **UNPLUG THE POWER CORD**. Using the hex key, turn both idler roller screws clockwise, 1/4 of a turn. When the walking belt is correctly tightened, you should be able to lift each edge of the walking belt 2 to 3 in. (5 to 7 cm) off the walking platform. Be careful to keep the walking belt centered. Then, plug in the power cord, insert the key, and carefully walk on the treadmill for a few minutes. Repeat until the walking belt is properly tightened.

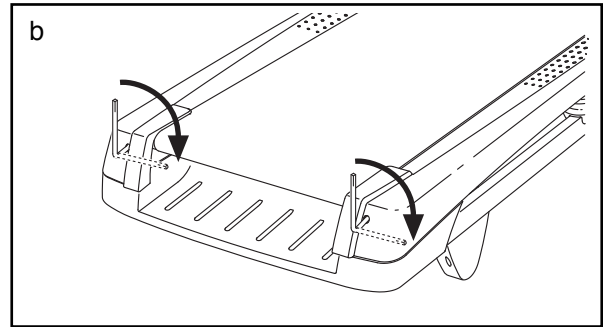

# EXERCISE GUIDELINES

**⚠️ WARNING:** Before beginning this or any exercise program, consult your physician. This is especially important for persons over age 35 or persons with pre-existing health problems.

The heart rate monitor is not a medical device. Various factors may affect the accuracy of heart rate readings. The heart rate monitor is intended only as an exercise aid in determining heart rate trends in general.

These guidelines will help you to plan your exercise program. For detailed exercise information, obtain a reputable book or consult your physician. Remember, proper nutrition and adequate rest are essential for successful results.

## EXERCISE INTENSITY

Whether your goal is to burn fat or to strengthen your cardiovascular system, exercising at the proper intensity is the key to achieving results. You can use your heart rate as a guide to find the proper intensity level. The chart below shows recommended heart rates for fat burning and aerobic exercise.

165	155	145	140	130	125	115	❤️
145	138	130	125	118	110	103	❤️
125	120	115	110	105	95	90	❤️
<hr/>							
20	30	40	50	60	70	80	

To find the proper intensity level, find your age at the bottom of the chart (ages are rounded off to the nearest ten years). The three numbers listed above your age define your “training zone.” The lowest number is the heart rate for fat burning, the middle number is the heart rate for maximum fat burning, and the highest number is the heart rate for aerobic exercise.

**Burning Fat**—To burn fat effectively, you must exercise at a low intensity level for a sustained period of time. During the first few minutes of exercise, your body uses carbohydrate calories for energy. Only after the first few minutes of exercise does your body begin to use stored fat calories for energy. If your goal is to burn fat, adjust the intensity of your exercise until your heart rate is near the lowest number in your training zone. For maximum fat burning, exercise with your heart rate near the middle number in your training zone.

**Aerobic Exercise**—If your goal is to strengthen your cardiovascular system, you must perform aerobic exercise, which is activity that requires large amounts of oxygen for prolonged periods of time. For aerobic exercise, adjust the intensity of your exercise until your heart rate is near the highest number in your training zone.

## WORKOUT GUIDELINES

**Warming Up**—Start with 5 to 10 minutes of stretching and light exercise. A warm-up increases your body temperature, heart rate, and circulation in preparation for exercise.

**Training Zone Exercise**—Exercise for 20 to 30 minutes with your heart rate in your training zone. (During the first few weeks of your exercise program, do not keep your heart rate in your training zone for longer than 20 minutes.) Breathe regularly and deeply as you exercise; never hold your breath.

**Cooling Down**—Finish with 5 to 10 minutes of stretching. Stretching increases the flexibility of your muscles and helps to prevent post-exercise problems.

## EXERCISE FREQUENCY

To maintain or improve your condition, complete three workouts each week, with at least one day of rest between workouts. After a few months of regular exercise, you may complete up to five workouts each week, if desired. Remember, the key to success is to make exercise a regular and enjoyable part of your everyday life.

# PART LIST

Model No. PFTL99912.2 R1114A

Key No.	Qty.	Description	Key No.	Qty.	Description
1	50	#8 x 1/2" Screw	51	1	Reed Switch Clip
2	40	#8 x 3/4" Screw	52	1	Reed Switch
3	1	3/8" x 2" Bolt	53	1	Magnet
4	1	3/8" x 1 3/4" Bolt	54	1	Drive Roller/Pulley
5	4	3/8" x 2 3/4" Screw	55	4	Cable Tie
6	4	3/8" x 1 1/4" Screw	56	1	Right Front Isolator Top
7	4	#10 x 3/4" Screw	57	1	Storage Latch
8	4	5/16" x 1/2" Screw	58	1	Drive Motor
9	1	#8 x 1/2" Ground Screw	59	1	Motor Belt
10	4	5/16" x 2 1/2" Screw	60	2	Rear Foot
11	10	5/16" Star Washer	61	1	Idler Roller
12	2	3/8" Nut	62	1	Right Foot Rail
13	4	3/8" Star Washer	63	1	Frame
14	4	#10 Star Washer	64	1	Motor Hood
15	13	#8 x 3/4" Tek Screw	65	1	Hood Accent
16	16	#8 x 3/4" Truss Head Screw	66	2	Frame Spacer
17	12	#8 x 3/4" Pan Head Tek Screw	67	2	Incline Frame Spacer
18	6	#10 x 1/2" Screw	68	1	Stop Bracket
19	3	1/4" x 2 1/2" Screw	69	1	Incline Motor
20	2	3/8" x 1 3/4" Screw	70	1	Incline Leg
21	5	#8 x 1/2" Machine Screw	71	1	Controller
22	1	3/8" x 1 1/2" Bolt	72	1	Controller Bracket
23	1	3/8" x 2" Bolt	73	2	Belly Pan Post
24	1	Power Cord Grommet	74	1	Power Switch
25	2	#8 x 1 3/4" Screw	75	1	Belly Pan
26	4	#8 Belt Guide Screw	76	1	Rear Endcap Cover
27	2	5/16" Motor Screw	77	1	Rear Endcap
28	2	1/2" x 2 1/4" Bolt	78	1	Upright Wire
29	2	3/8" x 1" Bolt	79	1	Left Upright
30	4	5/16" x 1 3/4" Bolt	80	2	Caution Decal
31	4	1/4" x 2 1/4" Screw	81	1	Left Base Cover
32	1	1/4" Nut	82	1	Left Handrail Cover
33	4	5/16" Flat Washer	83	1	Left Handrail
34	2	1/2" Nut	84	1	Left Bottom Handrail Cover
35	6	3/8" Jam Nut	85	1	Right Handrail Cover
36	4	5/16" Nut	86	1	Right Handrail
37	5	Hood Clip	87	1	Right Bottom Handrail Cover
38	4	Rubber Grommet	88	1	Right Upright
39	6	#8 x 5/8" Screw	89	1	Right Base Cover
40	2	5/16" x 1 1/2" Screw	90	2	Grommet
41	4	#4 Fan Screw	91	4	Base Pad
42	1	Left Front Isolator Top	92	2	Wheel
43	2	Rear Isolator Top	93	1	Right Wheel Cap
44	4	Isolator	94	1	Left Wheel Cap
45	4	Isolator Bottom	95	1	Base
46	1	Walking Belt	96	1	Console Frame
47	1	Warning Decal	97	2	Console Bracket
48	1	Walking Platform	98	2	Console Ground Wire
49	2	Belt Guide	99	1	Key/Clip
50	1	Left Foot Rail	100	1	Console Cover

Key No.	Qty.	Description	Key No.	Qty.	Description
101	1	Console	109	1	Fan Cover
102	1	Left Tray	110	1	Fan Grill
103	1	Right Tray	111	1	Fan
104	2	Tie	112	2	Incline Motor Spacer
105	1	Console Base	113	1	Power Cord
106	1	Console Trim	114	1	Controller Clamp
107	1	Pulse Bar	115	2	Controller Bracket Clip
108	1	Pulse Bar Bottom	*	–	User's Manual

Note: Specifications are subject to change without notice. For information about ordering replacement parts, see the back cover of this manual. \*These parts are not illustrated.

# EXPLODED DRAWING A

Model No. PFTL99912.2 R1114A

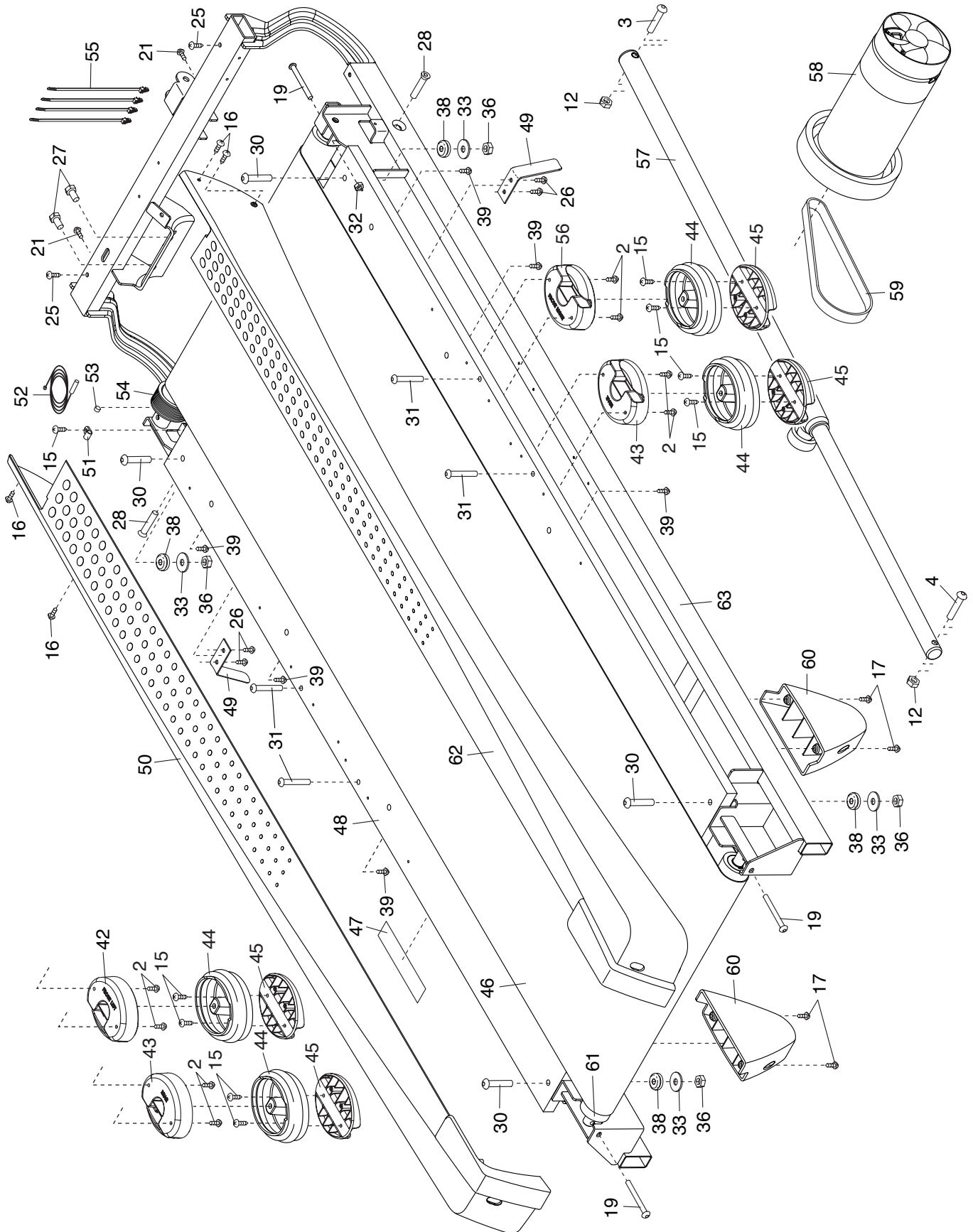

# EXPLODED DRAWING B

Model No. PFTL99912.2 R1114A

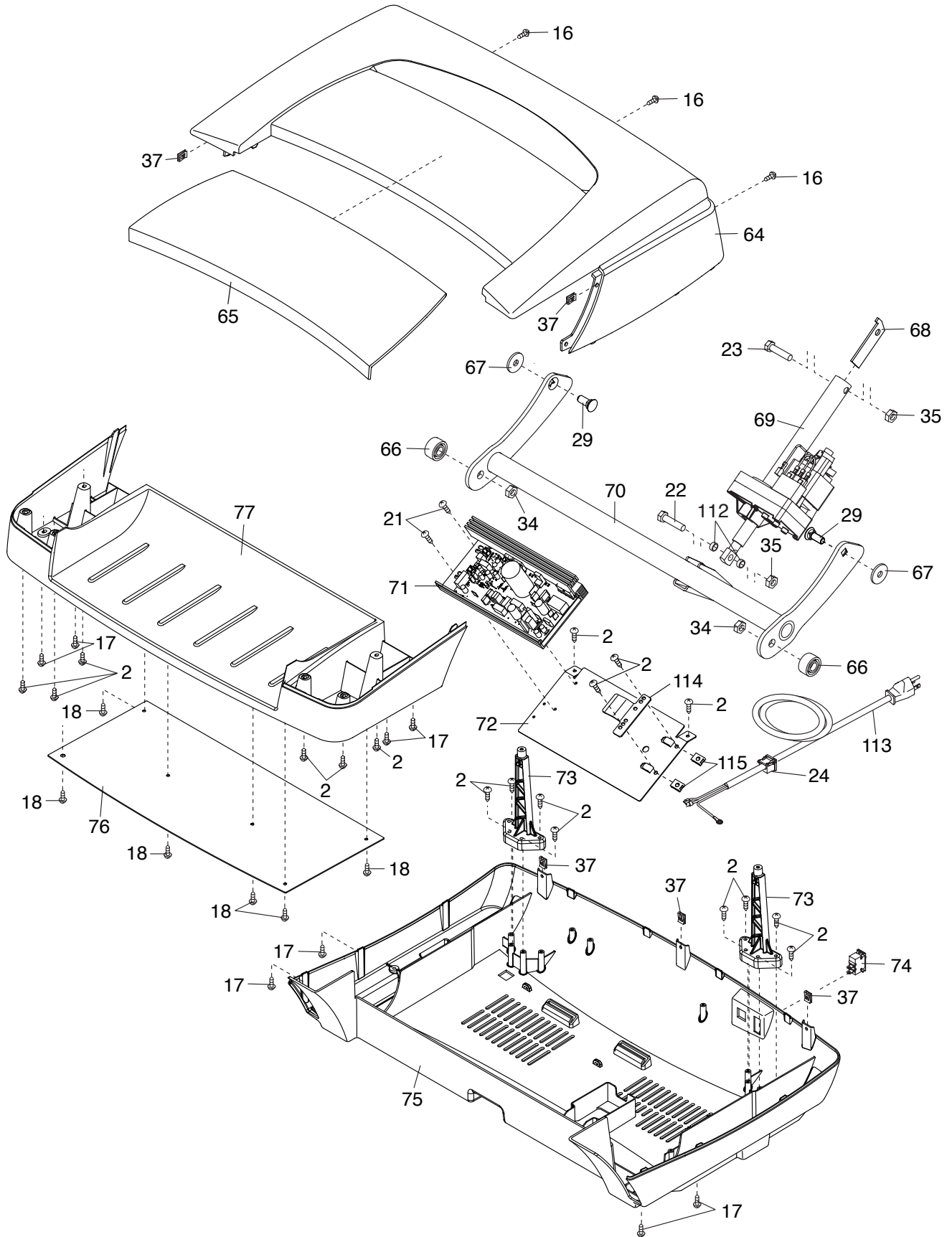

# EXPLODED DRAWING C

Model No. PFTL99912.2 R1114A

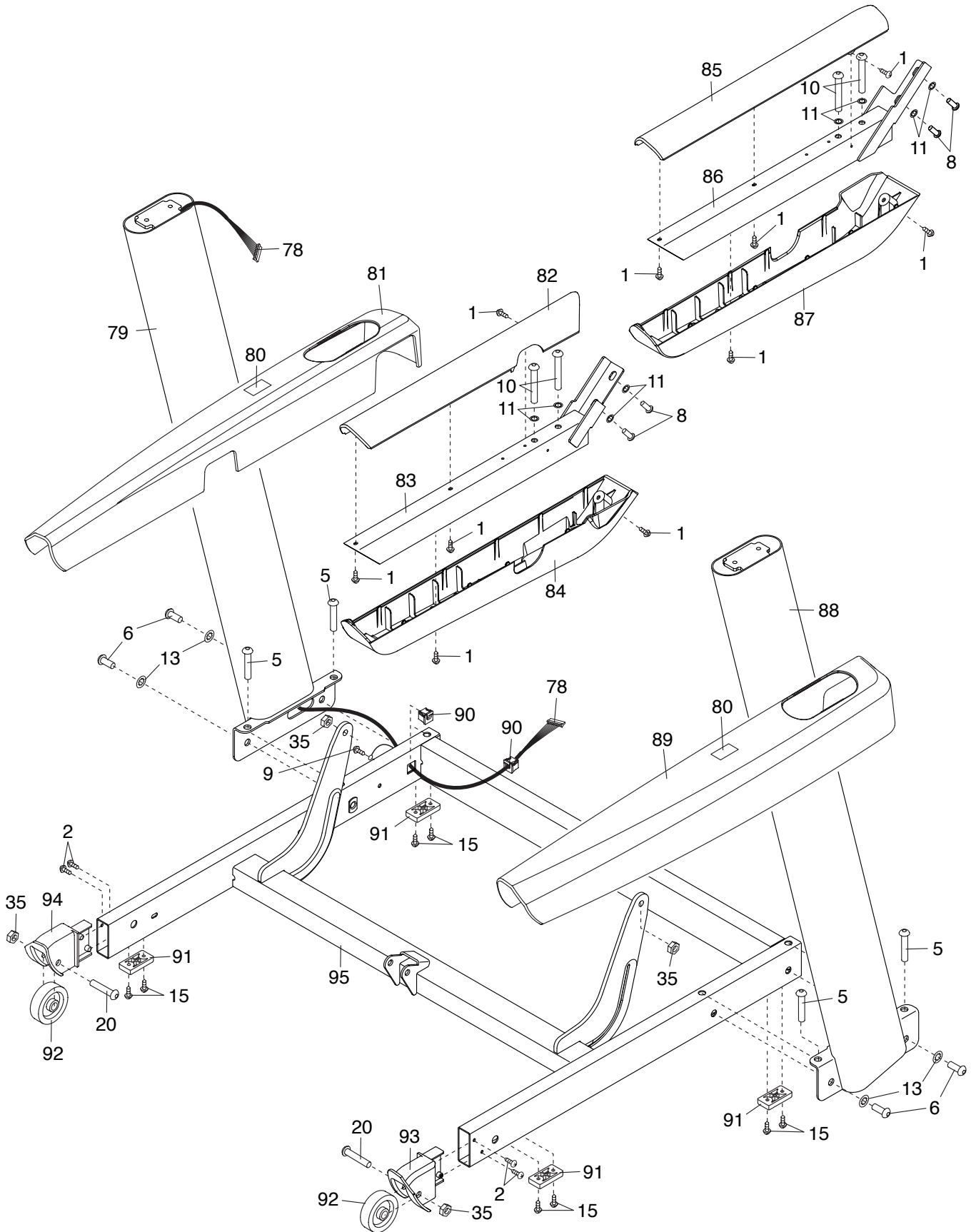

# EXPLODED DRAWING D

Model No. PFTL99912.2 R1114A

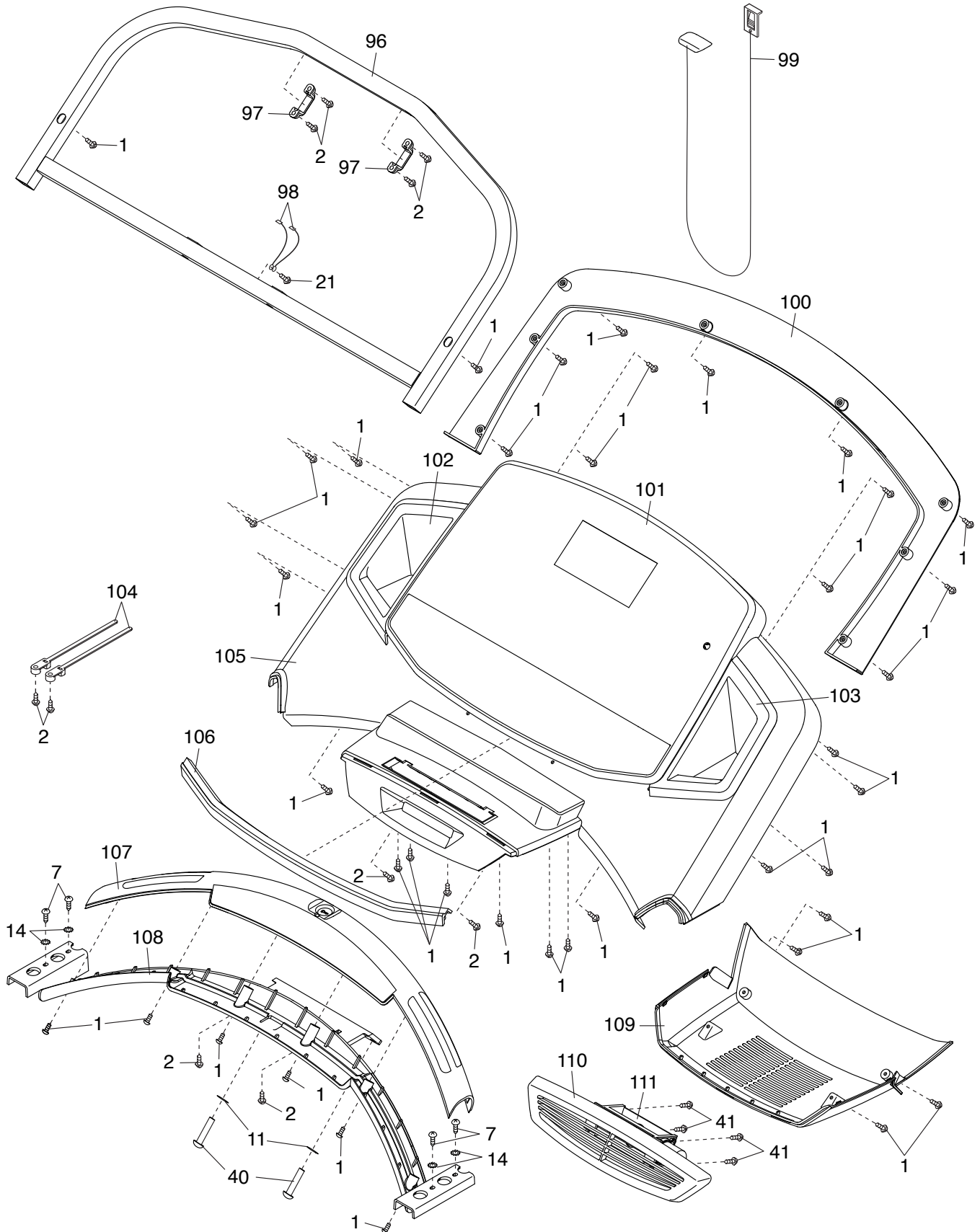

---

# ORDERING REPLACEMENT PARTS

To order replacement parts, please see the front cover of this manual. To help us assist you, be prepared to provide the following information when contacting us:

- the model number and serial number of the product (see the front cover of this manual)
- the name of the product (see the front cover of this manual)
- the key number and description of the replacement part(s) (see the PART LIST and the EXPLODED DRAWING near the end of this manual)

## LIMITED WARRANTY

**IMPORTANT: You must register this product within 30 days of the purchase date to avoid added fees for service needed under warranty. Go to [www.proformservice.com/registration](http://www.proformservice.com/registration).**

ICON Health & Fitness, Inc. (ICON) warrants this product to be free from defects in workmanship and material, under normal use and service conditions. The frame and drive motor are warranted for a lifetime. Parts are warranted for three (3) years from the date of purchase. Labor is warranted for one (1) year from the date of purchase.

This warranty extends only to the original purchaser (customer). ICON's obligation under this warranty is limited to repairing or replacing, at ICON's option, the product through one of its authorized service centers. All repairs for which warranty claims are made must be preauthorized by ICON. If the product is shipped to a service center, freight charges to and from the service center will be the customer's responsibility. If replacement parts are shipped while the product is under warranty, the customer will be responsible for a minimal handling charge. For in-home service, the customer will be responsible for a minimal trip charge. This warranty does not extend to freight damage to the product. This warranty will automatically be voided if the product is used as a store display model, if the product is purchased or transported outside the USA, if all instructions in this manual are not followed, if the product is abused or improperly or abnormally used, or if the product is used for commercial or rental purposes. No other warranty beyond that specifically set forth above is authorized by ICON.

ICON is not responsible or liable for indirect, special, or consequential damages arising out of or in connection with the use or performance of the product; damages with respect to any economic loss, loss of property, loss of revenues or profits, loss of enjoyment or use, or costs of removal or installation; or other consequential damages of any kind. Some states do not allow the exclusion or limitation of incidental or consequential damages. Accordingly, the above limitation may not apply to the customer.

The warranty extended hereunder is in lieu of any and all other warranties, and any implied warranties of merchantability or fitness for a particular purpose are limited in their scope and duration to the terms set forth herein. Some states do not allow limitations on how long an implied warranty lasts. Accordingly, the above limitation may not apply to the customer.

This warranty provides specific legal rights; the customer may have other rights that vary from state to state.

**ICON Health & Fitness, Inc., 1500 S. 1000 W., Logan, UT 84321-9813**