

SERVICE

(U.S.) Should your Nady Wireless Microphone System require service, please contact the Nady Service Department via telephone at (510) 652-2411 or e-mail to service@nady.com for a Return Authorization (R/A) Number and a service quote (if out of warranty). Make sure the R/A Number is clearly marked on the outside of the package and enclose a cashier's check or money order (if not prepaid with a credit card). Ship the unit prepaid to: Nady Systems, Inc., Service Department, 6701 Shellmound Street, Emeryville, CA 94608. Include a brief description of the problems you are experiencing.

The warranty card enclosed with this system contains additional valuable warranty and service information. Keep it in a safe place for future possible reference. Do not attempt to service this unit yourself as it will void the warranty.

(International) For service, please contact the Nady distributor in your country through the dealer from whom you purchased this product.

Nady Wireless Systems are type accepted under FCC rules part 74. The Device complies with RSS-210 of Industry & Science Canada. Operation is subject to the following two conditions: (1) this device may not cause harmful interference and (2) this device must accept any interference received. Including interference that may cause undesired operation.



NADY SYSTEMS, INC.

6701 Shellmound Street • Emeryville, CA 94608 USA
Tel: 510/652-2411 • Fax: 510/652-5075
www.nady.com



UHF-4

**Single Channel UHF DigiTRU Diversity™
Wireless System**



OWNER'S MANUAL

CONTENTS

CONTENTS	2
INTRODUCTION	2
USING THIS MANUAL	2
SYSTEM FEATURES	3
UHF-4 RECEIVER	4
UH-4 HANDHELD MICROPHONE TRANSMITTER	7
UB-4 BODYPACK MICROPHONE TRANSMITTER	8
SPECIFICATIONS	11
SERVICE	Back Cover

INTRODUCTION

Thank you for purchasing a Nady UHF-4 Diversity Wireless Microphone System and congratulations on your choice. The UHF-4 is loaded with top professional operating features and is the best performance and price value available in UHF diversity wireless systems.

USING THIS MANUAL

This booklet gives instructions for the operation of the UHF-4 wireless, including handheld, instrument, lavalier, headmic and plug-in transmitter systems. Please read the instructions for your system completely before operating unit.

This manual will first list the features of the UHF-4 and then will take you step by step to show you how to operate your new system. After reading the receiver instructions, turn to the section of the booklet that covers the type of transmitter used with your new system. Each section will give you detailed operating instructions. Also included in this manual are system specifications and servicing information.

SPECIFICATIONS

UHF-4 OVERALL SYSTEM PERFORMANCE

Frequency Response	30 Hz - 18 KHz, +/- 3 dB
Dynamic Range	120 dB
Total Harmonic Distortion	< 0.6%
RF Carrier Frequency Range	UHF; choice of single frequencies in separate bands within 720-805 MHz
Frequency Stability	+/- 0.005%, crystal controlled
Modulation	FM (F3E), +/-20KHz normal
Operating Range	Up to 250 ft. typical (depending on site conditions); up to 500+ feet optimum line-of-sight

RECEIVER

Reception Mode	DigiTRU Diversity™ (Dual Antenna)
Squelch	External Control, Tone Key (30.768 KHz)
Controls	Power ON/OFF, Volume Control, Squelch (Mute) Adjust
Connectors	DC in, 1/4" (6.3 mm) unbalanced phone jack (360 mV/ no load), XLR balanced output (+/-24 mV/600 Ohm load)
LED Indicators	Power ON, Diversity A/B, Audio LED Bars + Peak
Unwanted Signal Rejection	60dB image and spurious
Power Requirements	DC 15V @ 300 mA, AC/DC adapter included
Dimensions (Max.)	1.75" x 7.5" x 8.1" (4.5 x 19 x 20.6 cm)
Weight	0.9 lbs (0.41 kg)
Antenna	3.5" (9.0 cm), dual telescopic

TRANSMITTERS

Audio Inputs	UB-4 Bodypack: 3.5mm locking mini-jack, switchable inputs: instrument, headworn mic, or lavalier mic UH-4 Handheld: Integral Nady DM-10D neodymium dynamic cartridge
Controls	UB-4: POWER/STANDBY/OFF, INSTRUMENT/ HEADWORN MIC/LAV MIC, INPUT LEVEL UH-4: POWER/STANDBY/OFF/INPUT LEVEL
LED Indicator	Single color (red), Unit "ON" (red), Low Battery Alert (red)
RF Power Out	50mW nominal (maximum allowed by FCC)
Harmonic & Spurious Emissions	<- 50 dB
Battery	UH-4: 9V Alkaline UB-4: 9V Alkaline
Battery Life	10 Hours
Dimensions	UB-4 Bodypack: 4.25" x 2.5" x 1.0" (10.8 cm x 6.4 cm x 2.5 cm) UH-4 Handheld: 9.5" x 2.0" (24 cm x 5.1 cm)
Weight	UB-4 Bodypack: 3.1 oz (88 g) without battery UH-4 Handheld: 6.6 oz (187 g) without battery

UB-4 BODYPACK MICROPHONE TRANSMITTER

1. Snap open the **BATTERY DOOR (22)** and insert a fresh 9V alkaline battery into the **BATTERY COMPARTMENT (23)**, observing the correct polarity. Fresh alkaline batteries can last up to 10 hours in use, but in order to ensure optimum performance, it is recommended that the battery be replaced after 6-8 hours of use.

2. The UB-4 is equipped with two **INPUT SELECTOR SWITCHES (24)** located under the cover on the circuit board for selecting the type of audio input you will be supplying to the transmitter. Select from the choice of three positions: **INSTRUMENT** (for guitar, bass, etc.)/ **HEADWORN MIC/ LAVALIER MIC.** (G/H/L).

There are two switches, one with selectable position G, H, L and the other with G, HL. To select inputs: (see chart on page 10)

A. Instrument — both switches to "G"

B. Headworn Mic — set one switch to "H" and the other to "HL"

C. Lavalier Mic — set one switch to "L" and the other to "HL"

3. The UB-4 is provided with a **3.5 mm LOCKING JACK (25)** for connecting the audio input selected. Connect either the **INSTRUMENT CORD (31)** or the **HEADWORN MIC (32)** or **LAVALIER MIC CORD (33)** as desired, according to the input selected. (Note: Use only the input audio source as per the input selected with the internal **AUDIO INPUT SELECTOR SWITCHES (24)** or the audio will not be optimal—a muddy or distorted sound may result.) To secure the connection, turn the slip ring on the plug clockwise to thread it on the jack. To unplug, reverse the process. Slip the transmitter into a pocket or **CLIP (29)** it on to your clothes or instrument strap (if using the UB-4 as an instrument transmitter).

4. Turn on the UB-4 by sliding the **OFF/STANDBY/ON SWITCH (26)** to the **STANDBY** position (transmitter on, audio muted) or the **ON** position (transmitter and audio both on). The **BATTERY INDICATOR LED (27)** will give a single quick flash, indicating usable battery strength. In the case of a dead or low battery, the LED either will not go on at all or will stay on continuously, indicating that the battery should be replaced with a fresh one.

5. The UB-4 transmitter is now ready to use. The **A or B DIVERSITY LED INDICATORS (13)** on the UHF-4 receiver should now be lit, indicating a received signal from the transmitter. Adjust the volume of the receiver as per the Audio Output Instrument Connections section of the above UHF-4 receiver instructions. For optimum performance, an **INPUT LEVEL CONTROL (28)** is provided on the top panel of the UB-4. Adjust the gain by turning the control with a small slot head screwdriver. It is recommended that this control be turned to maximum gain. However, for ultra high-gain instrument sources such as active bass pickups or even extra hot guitar pickups, turning the level down slightly will create a cleaner sound. (Note: Turning down the input gain too much can compromise the signal-to-noise ratio and is not recommended. Set for the maximum possible gain and headroom without noticeable distortion on the high level peaks).

The **AF LEVEL LED DISPLAY (13)** on the UHF-4 receiver will light up to 5 LEDs (4 green and 1 red) for all input signals. Occasional flickering on and off during use of the top red LED indicator in this display is normal, however if the red LED stays on continuously, turn down the instrument volume or adjust the **INPUT LEVEL CONTROL (28)** on the UB-4 transmitter, or noticeable distortion may result.

5. Connecting the Audio Output

The UHF-4 receiver provides both a fixed mic level **BALANCED MIC AUDIO OUTPUT XLR (7)** and an adjustable line level **AUX AUDIO OUTPUT 1/4" jack (10)**.

(Note: As when making any connection, make sure the amplifier or mixing board volume is at the minimum level before plugging in the receiver to avoid possible sound system damage.)

Microphone Connection

(using the UB-4 transmitter with either a headworn or lavalier microphone or the UH-4 handheld microphone transmitter) For microphone use, either the **BALANCED MIC AUDIO OUTPUT XLR (7)** or the 1/4" line level **AUX AUDIO OUTPUT (10)** can be used. The XLR output is set at a non-adjustable microphone level, similar to hardwired mic levels. Plug an XLR connector into the XLR output socket on the rear of the unit and plug the other end into your amplifier or mixing board. Make sure the phantom power on your mixing board is turned off and the volume is turned down when making connections. For your convenience, the XLR output level is preset at the factory and is not adjustable with the receiver volume control.

To use the 1/4" **AUX AUDIO OUTPUT** socket, follow the instructions for the Instrument Connection (above), except start the receiver volume at 1/2 MAX and adjust until the volume level is optimal. If the volume control is set too high, you may overload your mixer or amp.

The UHF-4 receiver is equipped with a 5 segment LED **AF LEVEL DISPLAY (14)**. Occasional flickering of the top AF Peak LED indicator on loud inputs to the transmitter is normal. If this LED lights continuously, decrease the volume to the transmitter or overload distortion may result.

UHF-4 RECEIVER

1. Rackmounting the Receiver

There are 2 options available for rackmounting the UHF-4 receiver: singly or side-by-side with another UHF-4 Series receiver.

- a. Single mounting: Remove the receiver **SIDE MOUNT CLIP (1)** from each side of the receiver (as shown) and slide in the optional **ERM-3 RACK EARS (2)**.
- b. Side-by-side double mounting: After removing the **SIDE MOUNT CLIPS (1)** from both UHF-4 receivers, join the two receivers with the **EJC-3 JOINING CLIP (3)** and attach the **ERM-33 RACK EARS (4)** as shown. (Note: Do not mount the receiver in a rack directly above an amplifier or other source of high heat—this could degrade the performance of the UHF-4. Always ensure adequate airflow and heat dissipation in any rack configuration.)

2. Powering the Receiver

Plug the **15V/0.3A AC/DC ADAPTER (5)** provided into the **DC INPUT JACK (9)** on the back of the receiver. Then plug the power supply into an AC outlet. Press the **POWER SWITCH (11)** once to turn on the receiver. The **POWER ON LED (12)** will now light and the receiver is operational.

3. Antennas

The UHF-4 receiver is supplied with **TELESCOPIC ANTENNAS (15)**. These should be extended fully to obtain maximum range. Optimal antenna position is 45 degrees from the receiver (at 90 degrees from each other). For maximum range, it is always best to maintain a line of sight (no obstructions) between the receiver antennas and the transmitter at all times whenever possible.

4. Mute (Squelch) Adjustment

In normal operation, the **SQUELCH CONTROL (6)** should be set fully clockwise to the factory preset RF level (Max. Sens.). However, in areas of high RF activity, the squelch (or mute, as it is sometimes called) may need to be adjusted to compensate for the adverse conditions in a particular location. If, with the transmitter off, the receiver's A and/or B **DIVERSITY LED INDICATORS (13)** flicker or stay on, the squelch control should be turned counterclockwise until the A and/or B LEDs extinguish. When the squelch is properly adjusted, the A or B LEDs will only light when the transmitter is turned on. Turning the squelch control too far counterclockwise will reduce the range, but yield a quieter squelch (mute) function. During operation, especially at ranges greater than 75 feet, one or the other of the A or B LEDs may alternate briefly. This is normal—the unit's DigiTRU Diversity™ reception ensures that the received audio will not be interrupted. When both LEDs extinguish, the transmitter is out of range for that given location, and the user should move closer to the receiver to re-establish the radio link.

6. Instrument Use

Secure the connection from the **GT CABLE (30)** by turning the slip ring on the plug into the transmitter clockwise to thread it on the jack. To unplug, reverse the process. Plug the 1/4" phone plug into the instrument. When ready to play, slide the audio **MUTE SWITCH (26)** to STANDBY position. Adjust the volume of the receiver as per the Audio Output Instrument Connection section of the above UHF-4 receiver instruction. (Note: The **INPUT LEVEL CONTROL (28)** is deactivated and not used when the UB-4 is in INSTRUMENT mode. Levels should be adjusted with the volume control of your instrument.)

(Note: Scratchy noises can sometimes occur when some electric guitars with dirty pots or connections are used with any wireless system. Therefore, the supplied **INSTRUMENT CORD (30)** has a factory installed capacitor inside the 1/4" plug. This capacitor provides first order filtering of the RF signal from the cord into the guitar and eliminates virtually all scratchy noises. Should your equipment still give you scratchy noises, we suggest these steps to eliminate them:

- 1) Make sure all guitar volume and tone pots are clean and all contacts are solid—this is very important.
- 2) A 47pf capacitor soldered across the hot to ground terminals of the guitar's volume and tone pots will provide extra filtering.)

7. Microphone Use (with either a lavalier or headworn microphone)

Secure the connection from the **LAVALIER (32)** or **HEADWORN MIC CORD (31)** by turning the slip ring on the plug into the transmitter clockwise to thread it on to the jack. To unplug, reverse the process. To use the lavalier mic, attach it at chest level. Do not place it too close to the mouth—a distance of about six inches usually works best. To use the headworn mic, place it on the head and adjust the boom so that the mic is about one inch to the side of the front of the mouth. As the microphone cord also serves as the antenna, be sure to extend it fully. Rolling up or shortening the cord may reduce the effective operating range—keep it as straight as possible. When ready to speak, slide the **OFF/STANDBY/ON SWITCH (26)** to the ON position. Adjust the volume of the receiver as per the Audio Output Microphone Connection section of the above UHF-4 receiver instruction. (Note: Observe care in selecting P.A. volume, transmitter location and speaker placement so that acoustic feedback (howling and screeching) will be avoided. Please also note the pickup pattern characteristics of the microphone selected. Omnidirectional mics pick up sound equally from all directions, and are prone to feedback if not used carefully. Unidirectional mics are more resistant to feedback, but pick up sound sources best that are directly in front of the mic. Also, mics that are farther from the sound source, such as lavaliers, require more acoustic gain and thus are also more prone to feedback than close-source mics such as handheld or headworn models that are used close to the mouth.)

For optimum performance, an **INPUT LEVEL CONTROL (28)** is provided. Adjust the gain by turning the control with a small screw driver. For lavalier mic use, it is recommended that the level be set at about 1/2 maximum. For headworn mic use, it may be advisable to turn the gain down somewhat, depending on the volume levels expected. In either application, experiment and set for maximum possible gain without audible distortion on the high level peaks. (Note: Turning down the gain too much can compromise the signal-to-noise and is not recommended.)

The UHF-4 receiver is equipped with a 5 segment LED **AF LEVEL DISPLAY (14)**. Occasional flickering of the top AF Peak LED indicator on loud inputs to the transmitter is normal. If this LED lights continuously, but if the LED stays lit continuously, turn down the **INPUT LEVEL CONTROL (28)** on the UB-4 transmitter, or noticeable distortion may result.

INPUT SELECTOR SWITCHES	
Instrument	
Headworn	
Lavalier	

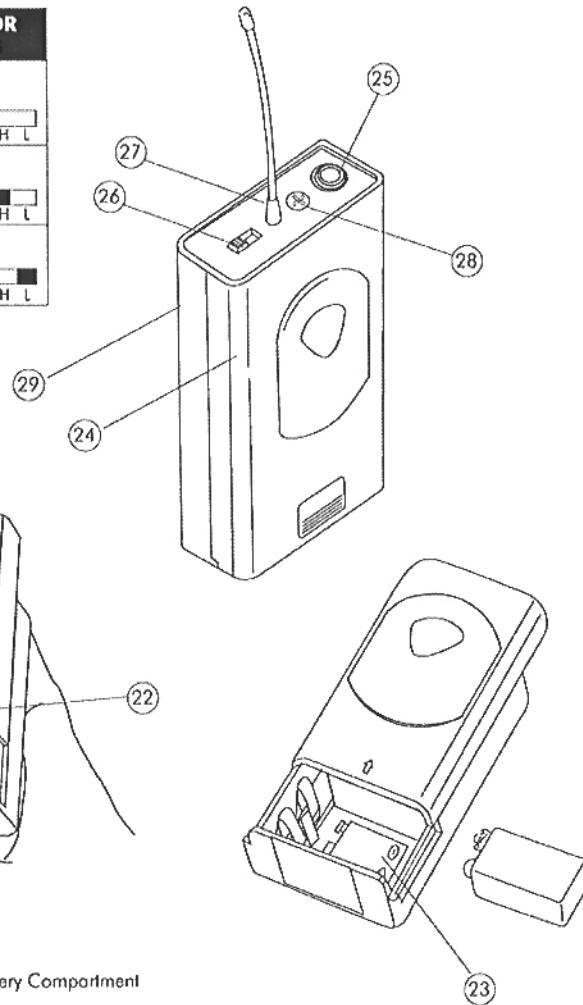

Opening Battery Compartment

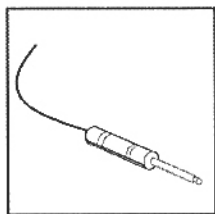

30

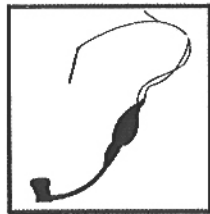

31

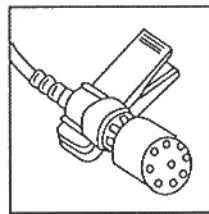

32

SYSTEM FEATURES

UHF-4 RECEIVER

- Unprecedented value in a full-featured single-channel UHF wireless mic system —with interference-free operation in any application or locale on select UHF frequencies from 720 to 805 Mhz
- Half-rack receiver design with retractable front panel dual antennas and unique snap-out panel locking tabs for single receiver or dual receiver (side-by-side) optional rack mounting
- Nady's proprietary companding circuitry for an industry best 120dB Dynamic Range, and the clearest, most natural sound available
- Tone Squelch™ for locking out potential interference
- UHF-4 receiver with DigiTRU Diversity™ for maximum range and dropout protection, full LED indicators, both 1/4" unbalanced and XLR balanced outputs, and special circuitry for noiseless transmitter ON/OFF switching
- Mute (squelch) adjust control
- Externally powered by AC/DC power adapter

UH-4 HANDHELD MIC TRANSMITTER

- Features the Nady DM -10D unidirectional neodymium dynamic cartridge for optimum true sound, maximum feedback rejection and minimal handling noise
- OFF / STANDBY / ON switch allows convenient audio muting with the transmitter "ON"
- Status LED indicator flashes once for unit "ON"; lights steady for low battery alert
- Easily accessible input level adjust control for optimum sound
- 9V alkaline or NiMH battery operation — rubber mic clip included

UB-4 BODYPACK TRANSMITTER

- Choice of instrument or headworn/lavalier microphone bodypack transmitter in a single unit
- OFF / STANDBY / ON switch allows convenient audio muting with the transmitter "ON"
- Status LED indicator flashes once for unit "ON"; lights steady for low battery alert
- Locking 3.5mm mini-jack provides secure connection for removable microphone or instrument cable
- Easily accessible input level adjust control for optimum sound
- 9V alkaline or NiMH battery operation

UH-4 HANDHELD MICROPHONE TRANSMITTER

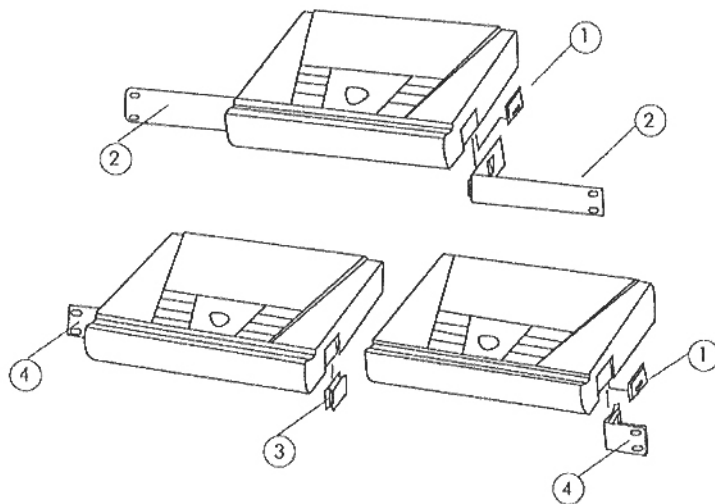
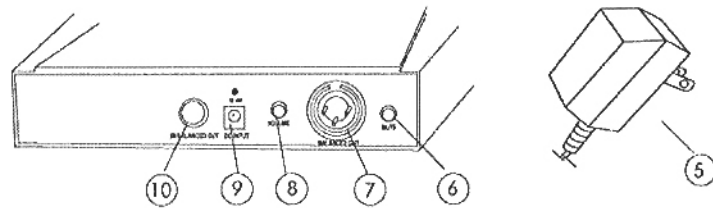
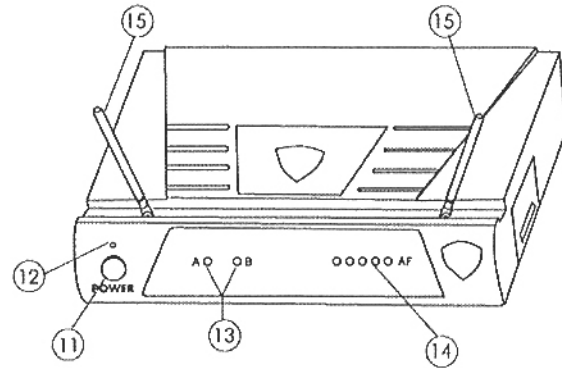

1. Unscrew the **BATTERY COMPARTMENT COVER (16)** and remove, exposing the **BATTERY HOLDER (17)**. Insert a fresh **9V ALKALINE BATTERY (18)**, observing the correct polarity as marked, and screw the cover back on to the microphone. Make sure the cover is screwed on completely. Fresh alkaline batteries can last up to 10 hours in use, but in order to ensure optimum performance, it is recommended that you replace the battery after every 6-8 hours of use.

2. Turn on the UH-4 by sliding the **OFF/STANDBY/ON SWITCH (19)** to the **STANDBY** position first (transmitter on, audio muted) or the **ON** position (transmitter and audio both on). The **BATTERY INDICATOR LED (20)** will give a single quick flash, indicating usable battery strength. In the case of a dead or low battery, the LED will either not go on at all or will stay on continuously, indicating that the battery should be replaced with a fresh one. To preserve battery life, turn the transmitter off when not in use.

3. The microphone is now ready to use. The **A or B DIVERSITY LED INDICATORS (13)** on the UHF-4 receiver should now be lit, indicating a received signal from the transmitter. When ready to speak, slide the **OFF/STANDBY/ON SWITCH (19)** to the **ON** position. Adjust the volume of the receiver as per the Audio Output Microphone Connection section of the above UHF-4 receiver instructions.

[Note: Observe care in selecting P.A. volume, transmitter location and speaker placement so that acoustic feedback (howling or screeching) will be avoided.]

4. For optimum performance, an **INPUT LEVEL CONTROL (21)** is provided. Adjust the gain by turning the control with a small screw driver. Set for maximum possible gain without audible distortion on the high level peaks. (Note: Turning down the gain too much can compromise the signal-to-noise and is not recommended.)

