

## ACTIVBOARD 300 PRO RANGE



**Installation Guide**



---

### **COPYRIGHT INFORMATION**

**© 2010 Promethean Limited. All rights reserved.**

This guide is distributed with the product. It may only be reproduced for use within the institution in which the product is used. For use outside of your institution, no part of this guide may be reproduced, transmitted, stored in a retrieval system or translated into any other language without the prior permission of Promethean Limited.

Please note that the content in this guide is protected under copyright law. Although every care has been taken in the compilation of this guide, Promethean Limited accepts no responsibility for errors or omissions, or for damages resulting from the use of information contained within the following pages.

# CONTENTS

<b>Welcome</b>	<b>4</b>
<b>Safety Information</b>	<b>4</b>
<b>Compliance</b>	<b>5</b>
<b>Installation</b>	<b>6</b>

# WELCOME

Thank you for purchasing an ActivBoard from Promethean. We recommend using our ActivBoard with our latest software, ActivInspire Professional Edition, which can be downloaded from [www.prometheanplanet.com](http://www.prometheanplanet.com).

For more information on the ActivClassroom by Promethean and other products available please visit [www.prometheanworld.com](http://www.prometheanworld.com).



## SAFETY INFORMATION

### Power Supply Unit

The Activboard 300 Pro range is powered by a power supply unit branded Promethean and type DT6018 or DPS-60SB A.

This is the only approved power supply unit. Do not connect any other power supply unit to the ActivBoard 300 Pro range.

The power supply unit is supplied with a suitable mains input lead specific to your country.

The power supply unit may also be supplied with more than one mains input lead, to accommodate countries with more than one type of mains outlet socket.

Only use the mains lead which is compatible with your mains outlet socket. Do not attempt to modify the mains lead.

If you are unsure of the electrical compatibility of your equipment, please contact Promethean or an authorised Promethean service agent before attempting to connect the power supply unit to the mains supply.

The power supply unit does not contain any user serviceable parts and must not be opened. If you suspect that the power supply unit is faulty, you should contact an authorised Promethean service agent to obtain a replacement.

Inspect the power supply unit for physical damage to the casing before use. If damage is apparent, take care to avoid contact with any potentially live parts. Disconnect the power supply unit from the mains supply at the wall socket and contact an authorised Promethean service agent for advice.

The ActivBoard does not contain any user serviceable parts. You should not attempt, under any circumstances, to gain access to internal parts of the unit.

If the ActivBoard is suspected to be faulty or damaged contact Promethean or an authorised Promethean service agent for advice.

### Environmental Considerations

Operating Temperature Range: 0°C to +50°C

Storage Temperature Range: -20°C to +70°C

Humidity (non condensing) 0% to 90%

**This document must be left with the product after installation. Please retain for your records.**

# COMPLIANCE

## United States of America

This device complies with Part 15 of the FCC rules. Operation is subject to the following two conditions:

1. This device may not cause harmful interference.
2. This device must accept any interference received, including interference that may cause undesired operation.

Changes or modifications to this equipment not expressly approved by Promethean may void the user's authority to operate this equipment.

For non-intentional radio parts, this equipment has been tested and found to comply with the limits for a Class B digital device, pursuant to part 15 of the FCC Rules. These limits are designed to provide reasonable protection against harmful interference in a residential installation.

This equipment generates, uses and can radiate radio frequency energy and, if not installed and used in accordance with the instructions, may cause harmful interference to radio communications. However, there is no guarantee that interference will not occur in a particular installation.

If this equipment does cause harmful interference to radio or television reception, which can be determined by turning the equipment off and on, the user is encouraged to try to correct the interference by one or more of the following measures:

- Reorient or relocate the receiving antenna.
- Increase the separation between the equipment and receiver.
- Connect the equipment into an outlet on a circuit different from that to which the receiver is connected.
- Consult the dealer or an experienced radio/TV technician for help.

## Canada

This device complies with RSS-210 of Industry Canada. Operation is subject to the following two conditions:

1. This device may not cause harmful interference.
2. This device must accept any interference received, including Interference that may cause undesired operation.

Changes or modifications to this equipment not expressly approved by Promethean may void the user's authority to operate this equipment.

This device also complies with RSS-102 of Industry Canada.

This Class B digital apparatus complies with Canadian ICES-003.

## Europe

The radio interface on this product (when fitted) is intended for use with Promethean radio devices for operation in the following countries:

Austria, Belgium, Bulgaria, Cyprus, Czech Republic, Denmark, Estonia, Finland, France, Germany, Greece, Hungary, Iceland, Ireland, Italy, Latvia, Lithuania, Luxembourg, Malta, Netherlands, Norway, Poland, Portugal, Romania, Slovak Republic, Slovenia, Spain, Sweden, Switzerland, United Kingdom.  
Declaration of Conformity Statement

Contact Promethean for a copy of the Declaration of Conformity for this product.



# INSTALLATION

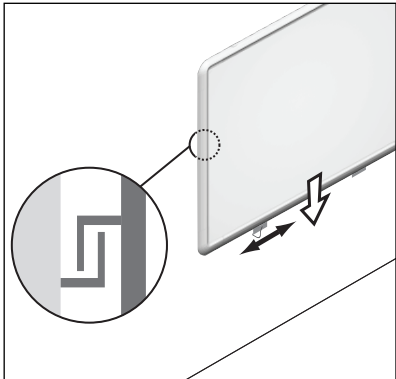
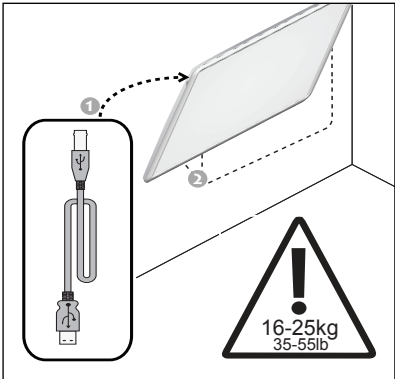
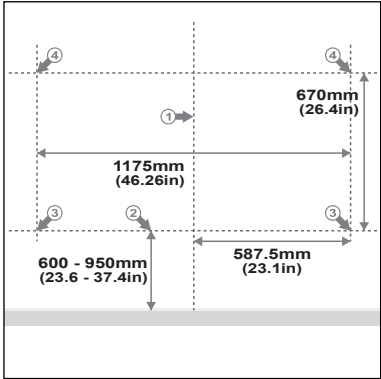
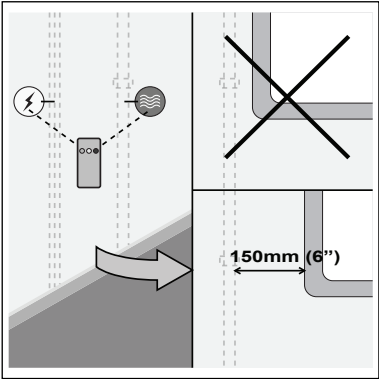
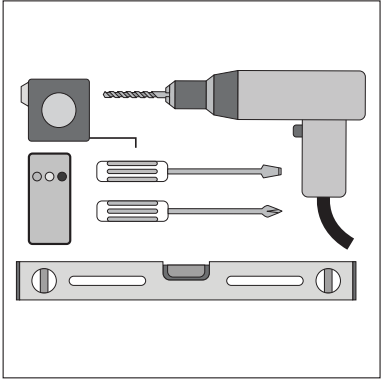
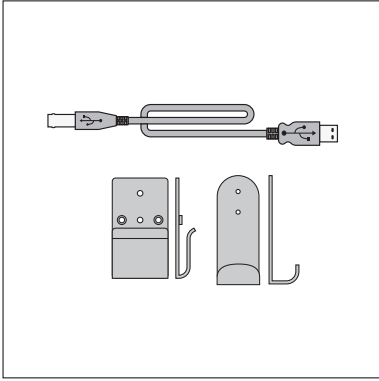

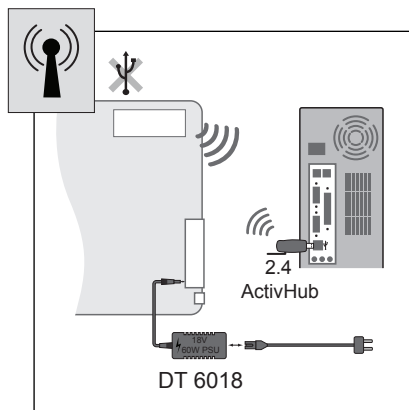
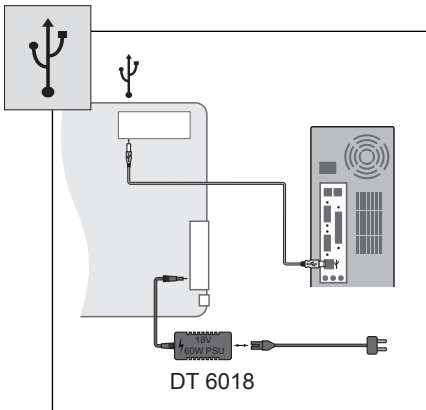
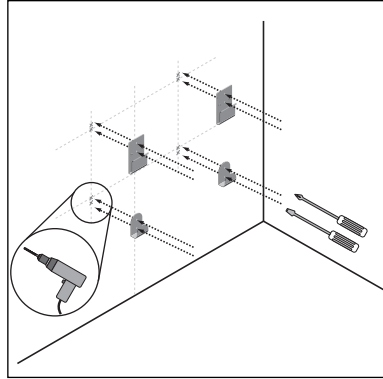
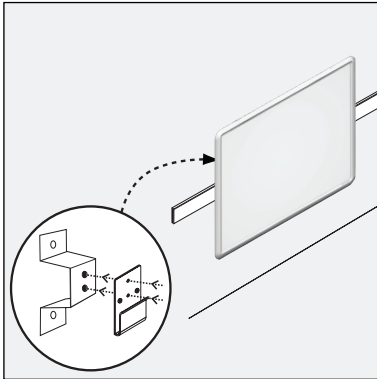
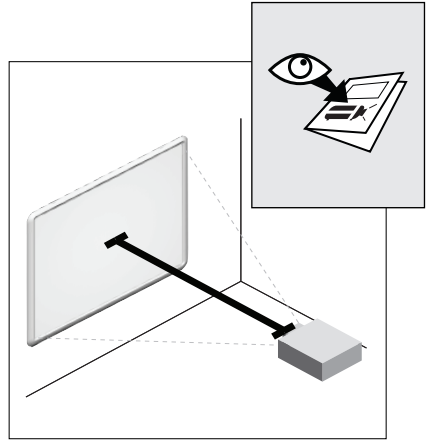
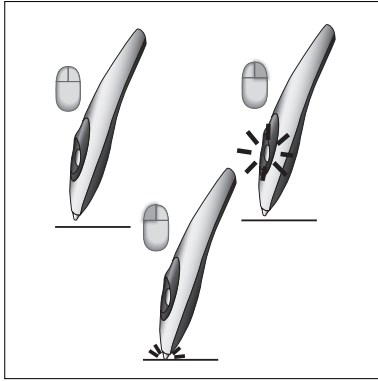

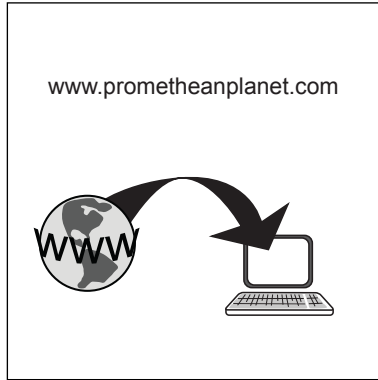
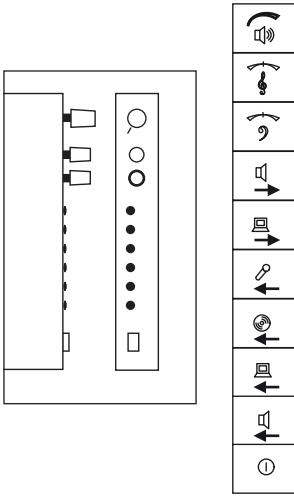

# CALIBRATION

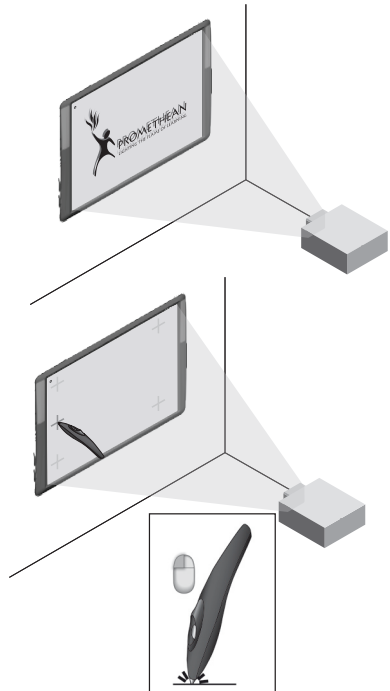
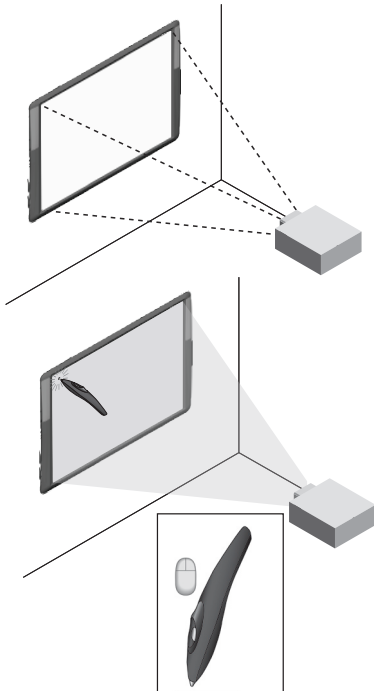



# SUPPORT

## **Asia Pacific**

+86 (0) 755 2983 2826 (English)

Promethean  
Room 2505  
Sino Plaza  
255-257 Gloucester Road  
Causeway Bay  
Hong Kong

## **Americas**

Call toll free, 1-888-65-ACTIV or 1-888-652-2848

Promethean  
1165 Sanctuary Parkway  
Suite 400  
Alpharetta, GA 30009  
USA

## **UK, Middle East and Africa**

Call 0844 855 2201 between 8am and 5.30pm, Monday to Friday

Promethean  
Promethean House  
Lower Philips Road  
Blackburn  
Lancashire  
BB1 5TH  
UK

<http://www.prometheankb.com/>



