

# Instruction Manual

## SL mini and SLR mini Series Speed and Length Gauges

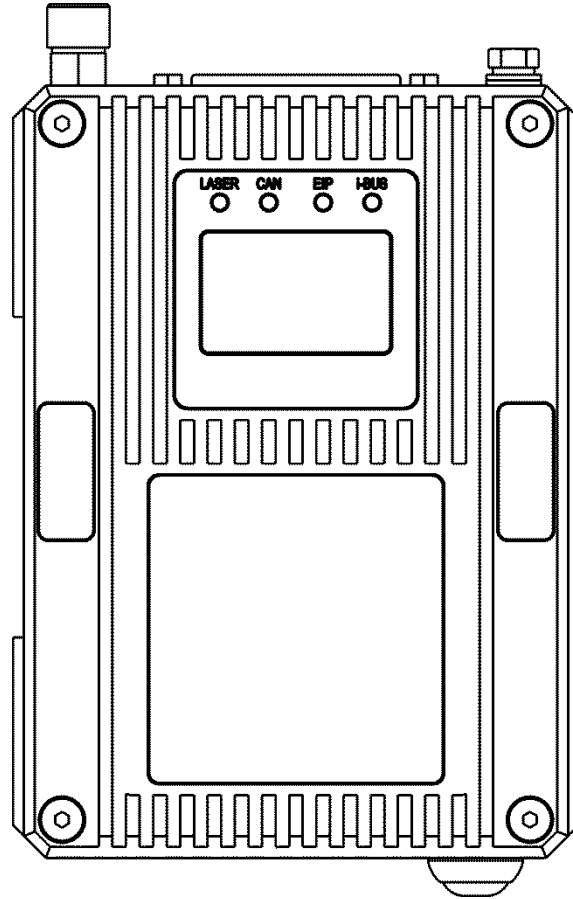

**Issue 1s**  
**5 December 2016**

**Proton Products International Ltd.**

**[www.protonproducts.com](http://www.protonproducts.com)**

## Table of Contents

<b>DECLARATION OF CONFORMITY (CE)</b> .....	<b>5</b>
<b>DECLARATION OF CONFORMITY (CSA)</b> .....	<b>6</b>
<b>LASER SAFETY PARAMETERS</b> .....	<b>7</b>
<b>INTRODUCTION</b> .....	<b>8</b>
<b>PRINCIPLE OF OPERATION</b> .....	<b>8</b>
<b>SPECIFICATIONS</b> .....	<b>9</b>
MODEL-SPECIFIC SPECIFICATIONS.....	9
COMMON SPECIFICATIONS.....	9
<b>DIMENSIONAL DRAWINGS</b> .....	<b>11</b>
<b>ANNOTATED DRAWINGS</b> .....	<b>12</b>
TOP VIEW .....	12
FRONT VIEW .....	12
REAR VIEW .....	13
UNDERSIDE VIEW .....	13
LED INDICATORS .....	14
<b>ON-GAUGE LCD DISPLAY</b> .....	<b>14</b>
<b>OPTIONAL ACCESSORIES</b> .....	<b>15</b>
DISPLAY .....	15
POWER.....	17
COMMUNICATIONS.....	18
STANDS AND GUARDS .....	18
PROTECTION.....	19
COOLING .....	20
<b>INSTALLATION</b> .....	<b>21</b>
PRECAUTIONS.....	21
<i>Operating and storage temperature</i> .....	21
<i>Protect from impact</i> .....	21
<i>Do not open or disassemble</i> .....	21
<i>Periodic maintenance</i> .....	22
<i>Laser radiation hazard</i> .....	22
<i>Optical windows</i> .....	23
OPTICAL WINDOW CLEANING PROCEDURE.....	24
INSTALLATION SEQUENCE .....	24
MECHANICAL INSTALLATION .....	25
<i>Stand-off distance and depth-of-field</i> .....	25
<i>Object stabilisation</i> .....	26
<i>Optical alignment</i> .....	27
<b>MEASUREMENT DIRECTION</b> .....	<b>29</b>
SL MINI UNIDIRECTIONAL SPEED AND LENGTH GAUGE .....	29
SLR MINI BIDIRECTIONAL SPEED AND LENGTH GAUGE.....	30
<i>Mechanical mounting</i> .....	30
ELECTRICAL INSTALLATION .....	31
<i>Earth connection</i> .....	31
<i>Shielded Cables</i> .....	31
LASER ENABLE .....	32
SHUTTER CONTROL SWITCH, SHUTTER ENABLE INPUT AND SHUTTER STATE OUTPUT .....	33
<i>SHUT_EN input electrical specifications</i> .....	33

<i>SHUT_ST output electrical specifications</i> .....	34
POWER SUPPLY .....	36
<i>Powering on the gauge</i> .....	36
<i>Powering off the gauge</i> .....	36
<b>CONFIGURATION .....</b>	<b>37</b>
PCIS_SLMINI SOFTWARE PC SYSTEM REQUIREMENTS .....	37
PCIS_SLMINI SOFTWARE INSTALLATION .....	37
CONNECTION AND SOFTWARE START UP .....	38
WIFI CONFIGURATION .....	41
<b>PCIS_SLMINI MAIN PAGE .....</b>	<b>45</b>
TREND GRAPH .....	46
<i>Context menu</i> .....	47
<i>Settings</i> .....	48
<b>MEASUREMENT CONFIGURATION .....</b>	<b>51</b>
<i>Normal Operation Mode</i> .....	54
<i>Batch Operation Mode</i> .....	54
<i>Object Detection Mode</i> .....	55
<b>STANDARD COMMUNICATIONS INTERFACES .....</b>	<b>57</b>
CAN-BUS COMMUNICATIONS .....	57
<i>CAN-bus interface</i> .....	57
<i>CAN-bus LED indicator</i> .....	57
<i>CAN-bus configuration</i> .....	58
RS-232 COMMUNICATIONS .....	60
<i>RS-232 interface</i> .....	60
<i>RS-232 Communications configuration</i> .....	61
<i>RS-232 Printing</i> .....	62
<i>Proton standard RS232 parameter access protocol</i> .....	65
<i>Modbus parameter access protocol</i> .....	67
ETHERNET COMMUNICATIONS .....	71
<i>Ethernet interface</i> .....	71
<i>Ethernet LED indicator</i> .....	71
<i>Ethernet configuration</i> .....	72
<i>Input Parameter Write Disable</i> .....	74
<i>UDP Protocol</i> .....	76
<b>OPTIONAL COMMUNICATIONS INTERFACES .....</b>	<b>78</b>
PROFIBUS COMMUNICATIONS .....	78
<i>PROFIBUS interface</i> .....	78
<i>PROFIBUS LED indicator</i> .....	78
<i>PROFIBUS configuration</i> .....	79
ETHERNET / IP OR PROFINET COMMUNICATIONS .....	80
<i>EtherNet / IP or PROFINET interface</i> .....	80
<i>EtherNet / IP or PROFINET LED indicator</i> .....	81
<i>EtherNet / IP or PROFINET configuration</i> .....	81
DEVICENET COMMUNICATIONS .....	83
<i>DeviceNet interface</i> .....	83
<i>DeviceNet LED indicator</i> .....	83
<i>DeviceNet configuration</i> .....	84
<b>STANDARD ELECTRICAL INTERFACES .....</b>	<b>86</b>
LOGIC INPUTS .....	86
<i>Logic inputs connection</i> .....	86
<i>Logic inputs configuration</i> .....	87
LOGIC OUTPUTS .....	91
<i>Logic outputs connection</i> .....	91

<i>Logic outputs electrical specifications</i> .....	91
<i>Logic outputs configuration</i> .....	92
PULSE OUTPUTS.....	95
<i>Pulse outputs connection</i> .....	95
<i>Pulse outputs electrical specifications</i> .....	96
<b>DATA LOGGING.....</b>	<b>103</b>
<b>CONNECTOR PIN OUTS .....</b>	<b>105</b>
<b>OPTIONAL PSU-BOB MINI.....</b>	<b>106</b>
CAN .....	106
RS232 .....	106
I-BUS.....	107
RJ45 SOCKET .....	107
SCREW TERMINALS .....	108
KEY SWITCH.....	109
DIMENSIONAL DRAWING.....	110
<b>INPUT PARAMETERS.....</b>	<b>111</b>
<b>OUTPUT PARAMETERS .....</b>	<b>114</b>
<b>APPENDIX 1: HIGH ACCURACY LENGTH MEASUREMENT OF DISCRETE OBJECTS</b>	
<b>APPLICATION NOTE .....</b>	<b>116</b>
PROBLEM .....	116
SOLUTION.....	116
IMPLEMENTATION .....	117
<i>Connections to the SL / SLR / SL mini / SLR mini gauge</i> .....	118
<i>Logic input electrical characteristics</i> .....	119
<i>Gauge software configuration</i> .....	119
EXAMPLE IMPLEMENTATION USING BANNER QS18 LASER EMITTERS AND QS186LE NPN SENSORS .....	121
<i>SL mini / SLR mini configuration</i> .....	122
<b>CONTACT DETAILS FOR ENQUIRIES, SALES AND SERVICE .....</b>	<b>126</b>
WEB SITE.....	126
ENQUIRIES AND SALES.....	126
SERVICE ENQUIRIES .....	126
<b>MANUAL FEEDBACK AND COPYRIGHT .....</b>	<b>126</b>

# DECLARATION OF CONFORMITY (CE)



This is to certify that the following equipment conforms to the requirements of CE including EMC to the heavy industrial standard Class A.

## Equipment Covered

Product name	Description	Part number
SL mini 1220	Unidirectional non-contact speed and length gauge (stand-off distance: 120mm, depth-of field: 20mm)	00050MC001
SL mini 3060	Unidirectional non-contact speed and length gauge (stand-off distance: 300mm, depth-of field: 60mm)	00050MC002
SLR mini 1220	Bidirectional non-contact speed and length gauge (stand-off distance: 120mm, depth-of field: 20mm)	00050MC011
SLR mini 3060	Bidirectional non-contact speed and length gauge (stand-off distance: 300mm, depth-of field: 60mm)	00050MC012

## The manufacturer of the above named equipment is:

Proton

Proton Products is an ISO9001:2008 registered company.

## The declaration is signed by:

Paul Alexander Sives

.....



# DECLARATION OF CONFORMITY (CSA)



This is to certify that the following equipment has been manufactured in compliance with the standards for Machine Safety and Workplace Electrical Safety according to the CSA (Canadian Standards Association).

## Equipment Covered

Product name	Description	Part number
SL mini 1220	Unidirectional non-contact speed and length gauge (stand-off distance: 120mm, depth-of field: 20mm)	00050MC001
SL mini 3060	Unidirectional non-contact speed and length gauge (stand-off distance: 300mm, depth-of field: 60mm)	00050MC002
SLR mini 1220	Bidirectional non-contact speed and length gauge (stand-off distance: 120mm, depth-of field: 20mm)	00050MC011
SLR mini 3060	Bidirectional non-contact speed and length gauge (stand-off distance: 300mm, depth-of field: 60mm)	00050MC012

The manufacturer of the above named equipment is:

Proton

Proton Products is an ISO9001:2008 registered company.



The declaration is signed by:

Paul Alexander Sives

.....

## LASER SAFETY PARAMETERS



[www.protonproducts.com](http://www.protonproducts.com)

Proton Products SL mini and SLR mini series laser speed and length gauges emit laser radiation with the following parameters:

Parameter	Model	Minimum	Typical	Maximum	Units
Wavelength	All	650	658	670	nm
Beam diameter	All			3	mm
Spot size at standoff distance	All			3	mm
Beam divergence	All			1.5	mrad
Total emitted power	SL mini			40	mW
	SLR mini			80	mW
Emitted power per beam (2 beams are emitted)	SL mini			20	mW
	SLR mini			40	mW
Power density at gauge window (normal operation)	SL mini			280	mW/cm <sup>2</sup>
	SLR mini			560	mW/cm <sup>2</sup>
Power density at gauge window (absolute maximum)	SL mini			560	mW/cm <sup>2</sup>
	SLR mini			1120	mW/cm <sup>2</sup>
Power density at standoff distance	SL mini			560	mW/cm <sup>2</sup>
	SLR mini			1120	mW/cm <sup>2</sup>
Nominal hazard zone (NHZ) distance (diffuse surface reflection)*	All	20 to 100			mm
Nominal hazard zone (NHZ) distance (specular / reflective surface reflection)	All	150			m

\*this distance is highly dependent on the nature and type of diffuse surface.

For further information, please contact your Proton Products representative or Proton Products

**Manufacturer signature:**

Paul Alexander Sives:  .....

Proton Products is an ISO9001:2008 registered company.



## INTRODUCTION

The Proton Products SL mini and SLR mini series of laser speed and length gauges provide highly-accurate, non-contact speed and length measurement.

SL mini series gauges offer speed and length measurement for unidirectional production lines.

SLR mini series gauges offer speed and length measurement for bidirectional production lines. The gauge senses the direction of motion and will automatically increment or decrement the length accordingly. SLR mini gauges are thus suitable for production lines that undergo direction reversals or stationary (zero speed) periods.

Compared to traditional contact wheel encoders, SL mini / SLR mini non-contact speed and length gauges offer the following advantages:

- Capable of measurement at much higher speeds and accelerations
- No slippage
- Greater accuracy
- No wear or damage to the measured object
- Solid state design results in higher reliability and MTBF

RS-232 and Ethernet communication interfaces are installed as standard for straightforward connection to computers or PLCs. One optional industrial standard communication interface (PROFIBUS, EtherNet/IP or DeviceNET; replaces the standard Ethernet interface) may also be installed in the gauge.

User configurable digital inputs are provided as standard to reset gauge measurements and trigger printing. User configurable digital outputs are provided as standard to signal gauge status and preset length reached.

## PRINCIPLE OF OPERATION

SL mini series unidirectional speed and length gauges illuminate the measured surface with a precisely pitched interference pattern created by the intersection of two laser beams. The alternating bright and dark interference fringes modulate the light scattered by the object with a frequency proportional to the object speed. This scattered light is detected by a photodiode and the electrical signal digitally processed to determine the frequency and hence the speed. Object length is then calculated by integrating the speed measurement over time.

SLR mini series bidirectional speed and length gauges extend this principle by using a high-frequency Bragg cell modulator to illuminate the measured surface with a scanning interference pattern, which generates an oscillating light signal even when the object is stationary. Direction of motion is determined by whether the scattered light frequency is higher or lower than the stationary frequency.



**PRINCIPLE OF OPERATION**

$$d = \frac{\lambda}{2 \sin \kappa}$$

- Fringe spacing is a function of laser wavelength and beam angle.

$$f \propto \frac{v}{d}$$

- Doppler frequency is proportional to speed and inversely proportional to fringe spacing.

$$L = \int_0^T v dt$$

- Speed is integrated to measure length.

**LASER BEAMS: SIDE VIEW**

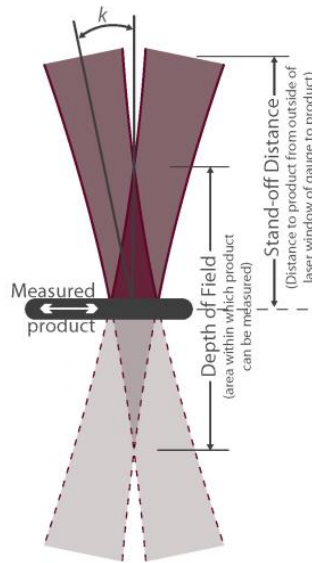

**LASER DOPPLER PATTERN**

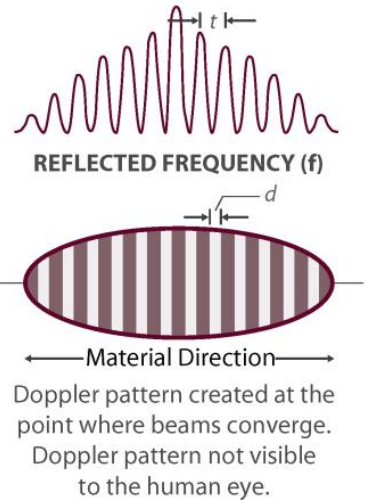

**SPECIFICATIONS**

**MODEL-SPECIFIC SPECIFICATIONS**

Specification	Unidirectional – SL mini		Bidirectional – SLR mini		Units
	1220	3060	1220	3060	
Minimum speed	0.1	0.25	0	0	m/min
Maximum speed	2000	5000	±2000	±5000	m/min
Nominal stand-off distance	120	300	120	300	mm
Depth of field	20	60	20	60	mm

**COMMON SPECIFICATIONS**

Specification	Minimum	Typical	Maximum	Units
Accuracy	-0.05		0.05	%
Repeatability	-0.02		0.02	%
Acceleration			1000	m/s <sup>2</sup>
Measurement update time			20	µs
Laser beam diameter			3	mm
Laser classification			3B	-
Operating temperature	+5		+40	°C
Environmental protection			IP67	-
Power supply voltage	15	24	28	VDC
Power consumption			15	W
Length			140	mm
Width			105	mm
Height			50	mm

Measurement display	Integrated backlit LCD	
Pulse outputs	2x RS-422 compliant differential pair outputs with maximum pulse rate < 2 MHz (cable length dependent), end-user configurable as:	
	2x independent pulse outputs	1x quadrature output
Laser safety	Laser enable input	Open shutter input

	Shutter status output	
3x Logic inputs (end-user configurable functions)	Reverse Direction	Length Hold
	Reset	Speed Hold
	End of Reel	Display Hold
2x Logic outputs (end-user configurable functions)	Gauge OK	Gauge too hot
	Good reading	Object detected
	Preset length 1 / Batch length reached	
	Preset length 2 / Batch number reached	
	Gauge measuring speed	
Standard communications interfaces	RS-232*	CANbus**
	Ethernet TCP/IP (Modbus protocol)	
Optional communications interface (select one; replaces the Ethernet interface)	PROFIBUS	PROFINET
	DeviceNet	EtherNet/IP

\*An optional RS-232-to-USB converter cable is available for connection to USB equipped computers.

\*\*CAN-bus protocol is proprietary and reserved for connection to other Proton Products equipment such as a CDI interface display unit.

# DIMENSIONAL DRAWINGS

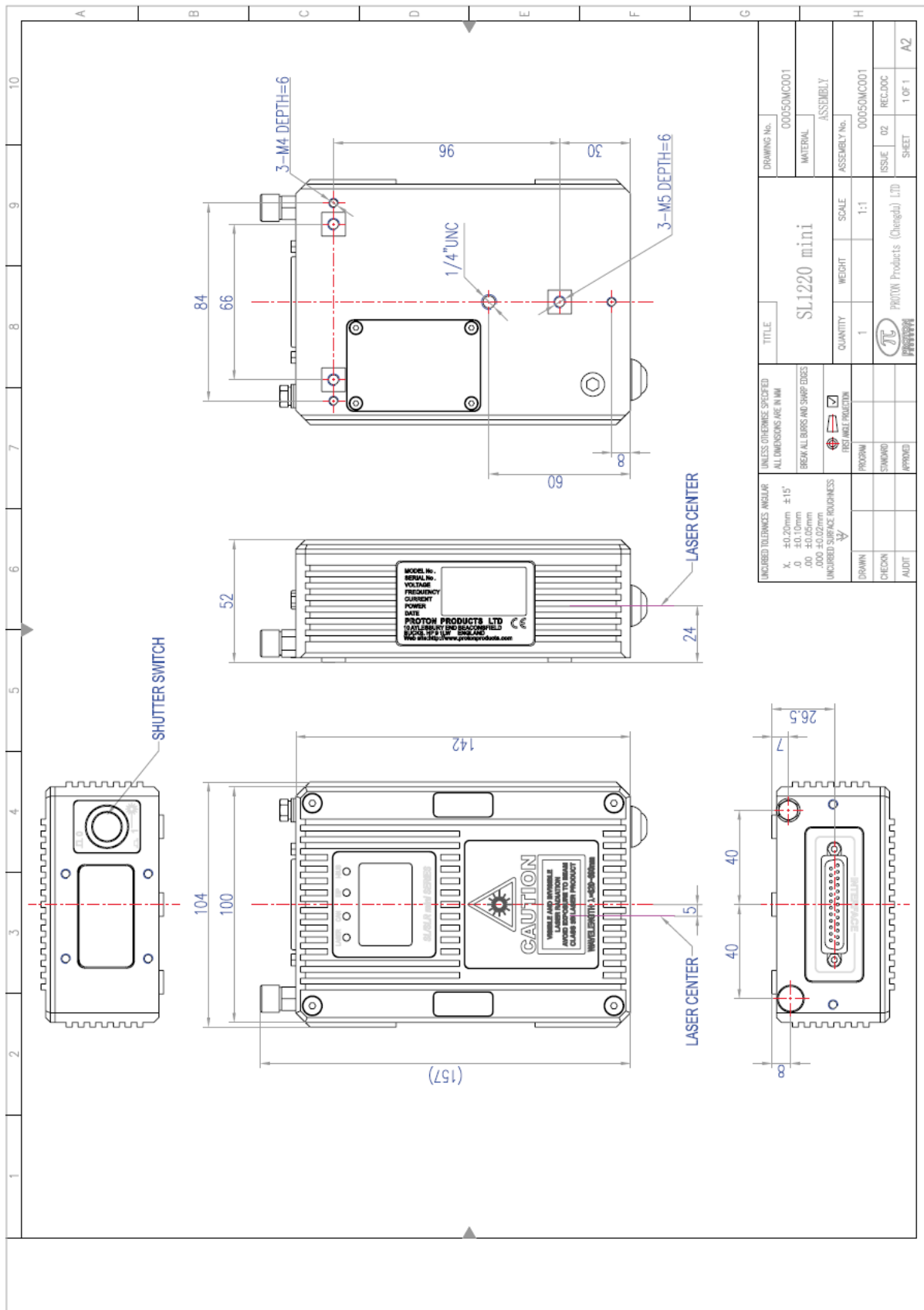

# ANNOTATED DRAWINGS

## TOP VIEW

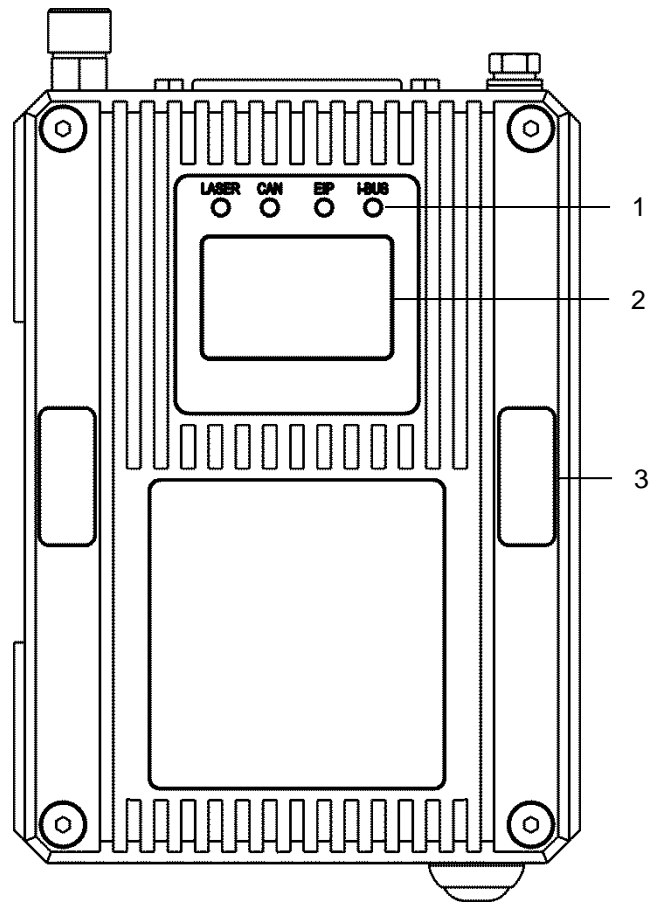

Label	Description
1	LED indicators
2	LCD display
3	Tamper-evident seal (x2; damage to or removal will invalidate the product warranty)

## FRONT VIEW

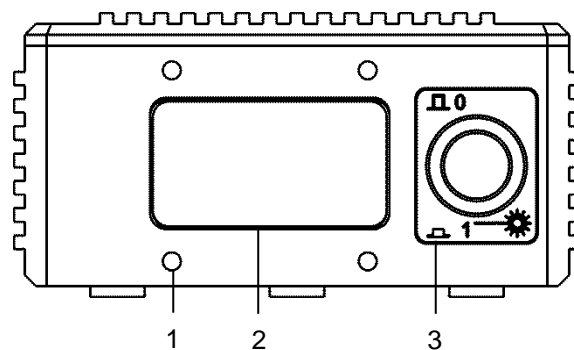

Label	Description		
1	Optional air wipe / beam enclosure tube mounting holes (x4)		
2	Optical window		
3	Laser shutter control switch		
	<b>Switch status</b>	<b>Laser shutter status</b>	<b>Laser beam status</b>
	Out	Closed	Blocked
	In	Open	Emitting

## REAR VIEW

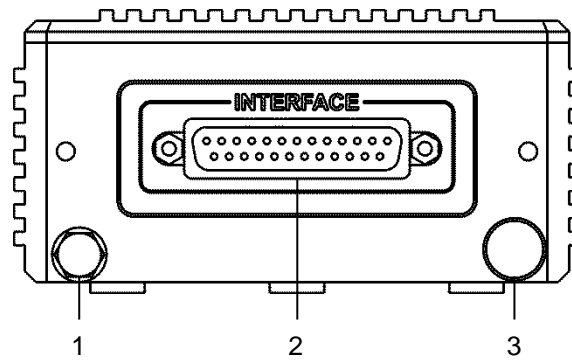

Label	Description
1	Earthing bolt
2	"INTERFACE" connector port
3	Nitrogen gas purge port (for factory use only; any attempt to open or connect to this port will invalidate the product warranty)

## UNDERSIDE VIEW

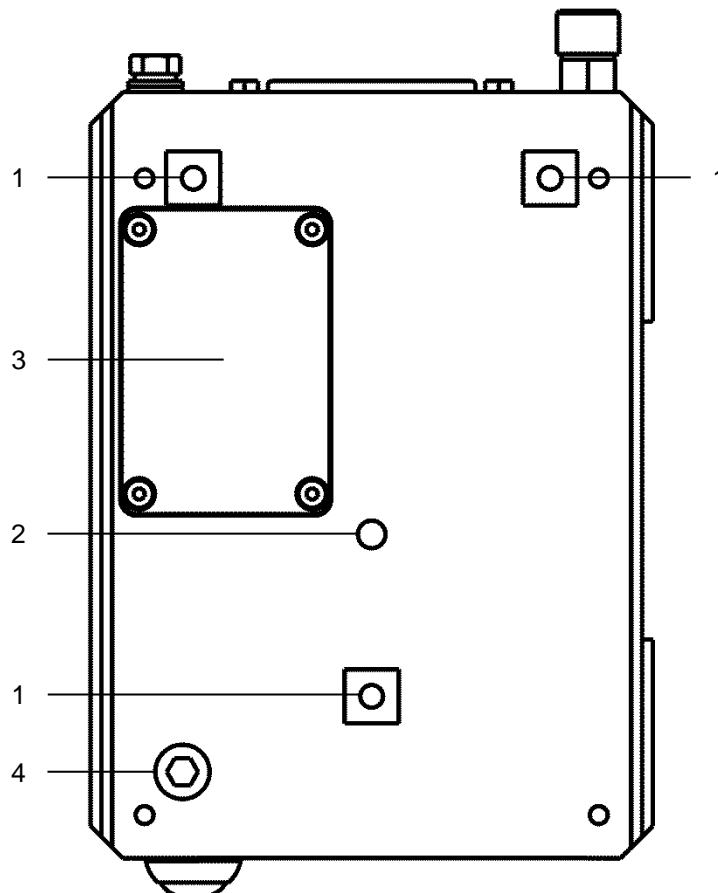

Label	Description
1	M5 threaded mounting hole (x3)
2	1/4"-20 UNC threaded tripod mounting hole
3	Communications module compartment cover
4	Nitrogen gas purge port (for factory use only; any attempt to open or connect to this port will invalidate the product warranty)

## LED INDICATORS

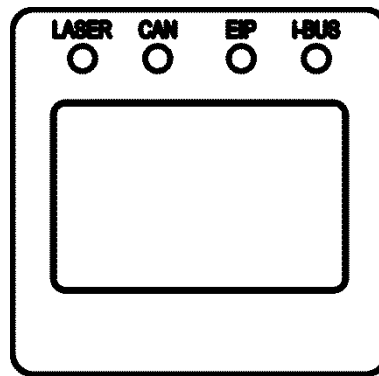



Label	Condition	Description
LASER	Extinguished	No laser emission
	Yellow	Laser emission
CAN	Extinguished	No CANbus connection
	Green	CANbus connected
EIP	Extinguished	No Ethernet connection
	Green	Ethernet connected
	Flashing red	Ethernet data transmission
i-BUS	Extinguished	Optional DeviceNET / PROFIBUS / PROFINET / EtherNet/IP not connected
	Green	Optional DeviceNET / PROFIBUS / PROFINET / EtherNet/IP connected

## ON-GAUGE LCD DISPLAY

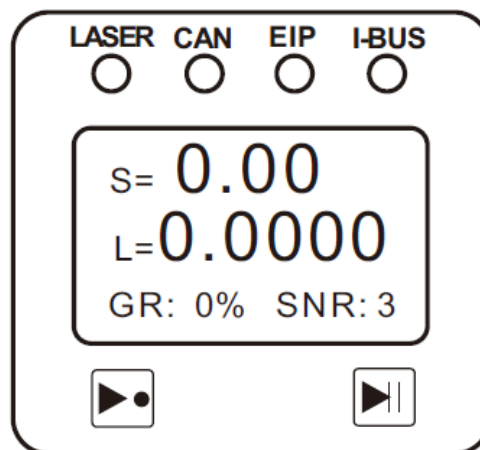

The SL mini and SLR mini gauges are fitted with a backlit, on-gauge LCD which displays the following information:



Label	Description	
S	Measured speed	
L	Measured length	
GR	Good Readings percentage	
SNR	Signal-to-Noise Ratio	
	Reset button	Press to reset the length to zero.
	Pause button	Press to pause the speed measurement.

## OPTIONAL ACCESSORIES

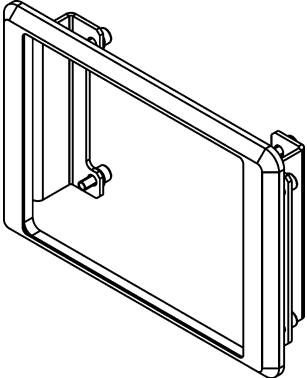
### DISPLAY

<b>AiG2-SL/SLR</b>	<b>Display module</b>		
	<ul style="list-style-type: none"> <li>• Connects via the CAN-bus port.</li> <li>• Displays measured speed and length.</li> <li>• Provides menu-based setting of all parameters.</li> <li>• Bright VFD dot matrix display.</li> </ul>		
Proton part number	00041MC045		
<b>AiG2 Panel Mount Kit</b>			
	<ul style="list-style-type: none"> <li>• Bracket for mounting the AiG2 to an end-user panel.</li> </ul>		
Proton part number	00041MC049		
<b>CAN-bus cable</b>			
	<b>Name</b>	<b>Length / m</b>	<b>Proton part number</b>
	CAN 9DD_001M	1	00041CB001
	CAN 9DD_005M	5	00041CB005
	CAN 9DD_010M	10	00041CB010
	CAN 9DD_020M	20	00041CB020
	CAN 9DD_040M	40	00041CB040
	CAN 9DD_060M	60	00041CB060
	CAN 9DD_100M	100	00041CB100

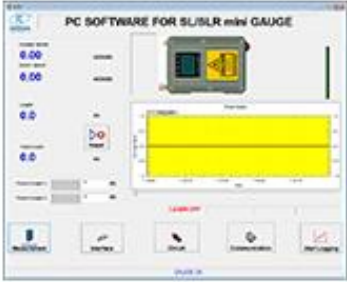
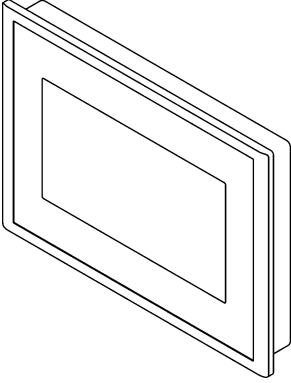
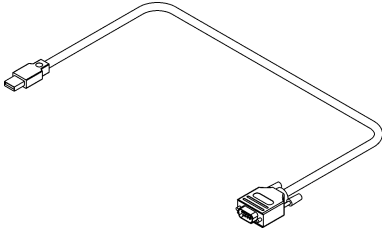
<b>PCiS_SL/SLR mini</b>	<b>PC Interface Software</b>
	<ul style="list-style-type: none"> <li>• PC-based software package.</li> <li>• User-friendly graphical user interface.</li> <li>• Displays all measurements.</li> <li>• Provides menu-based setting of all parameters.</li> <li>• Provides trending, data logging, presets and alarms.</li> <li>• Gauge to PC connection via RS-232.</li> </ul>
Proton part number	00050SW001
<b>7" Touch Screen PC</b>	<b>Industrial PC</b>
	<ul style="list-style-type: none"> <li>• For running the above PCiS_SL/SLR mini software</li> <li>• User-friendly graphical user interface.</li> <li>• Displays all measurements.</li> <li>• Provides menu-based setting of all parameters.</li> <li>• Provides trending, data logging, presets and alarms.</li> <li>• Gauge to PC connection via RS-232 or optional RS-232-to-USB interface cable (RSCon).</li> </ul>
Proton part number	00043MC029
<b>USB-RS232 Cable</b>	
	<ul style="list-style-type: none"> <li>• For connecting the RS232 port of the PSU-BOB mini to the 7" Touch Screen PC.</li> <li>• Length: 1.8m.</li> </ul>
Proton part number	GP00000624

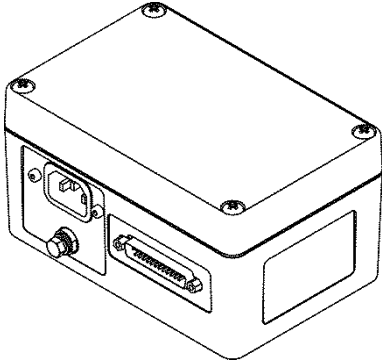

## POWER

PSU-BOB mini	Power supply and mini break out box
	<ul style="list-style-type: none"> <li>• Connects via the DB25 “INTERFACE” connector.</li> <li>• Supplies 24VDC electrical power to the gauge.</li> <li>• Provides screw terminal access to all electrical interfaces.</li> <li>• Provides DB9 connectors for access to the CANbus, RS232 and industrial bus communications interfaces.</li> <li>• Provides a RJ45 socket for the Ethernet interface.</li> <li>• End user cables are sealed with three cable glands.</li> <li>• Input voltage range: 90 – 260 VAC @ 45 – 65 Hz.</li> <li>• Select the required length of DB25 cable from below.</li> </ul>
Proton part number	00050MC039

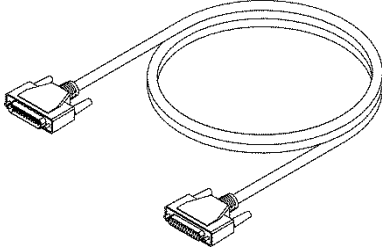
DB25 “INTERFACE” port to PSU-BOB mini cable			
	Name	Length / m	Proton part number
	BOB 25DD_001M	1	00041CT001
	BOB 25DD_003M	3	00041CT003
	BOB 25DD_005M	5	00041CT005
	BOB 25DD_010M	10	00041CT010
	BOB 25DD_020M	20	00041CT020
	BOB 25DD_030M	30	00041CT030

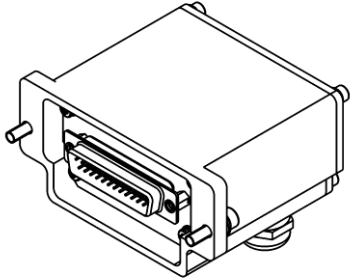
Terminal Expander	Gauge-mounted break-out box
	<ul style="list-style-type: none"> <li>• Connects via the DB25 “INTERFACE” connector.</li> <li>• Provides DB9 connector access to the RS-232, CANbus, Ethernet or optional industrial bus communications ports.</li> <li>• Provides screw terminal access to all electrical input and output pins.</li> <li>• End user cables are sealed with cable glands.</li> </ul>
Proton part number	00050MC039

## COMMUNICATIONS

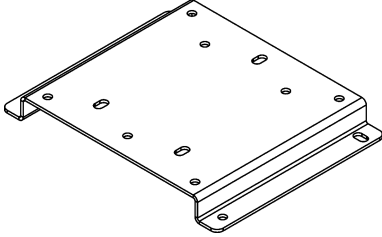
<b>Industrial Bus Module</b>	<b>For connecting the gauge to industrial communications buses, such as used with PLCs.</b>											
	<ul style="list-style-type: none"> <li>• May be field retrofitted.</li> </ul>											
	<table border="1"> <thead> <tr> <th data-bbox="756 501 893 533">Protocol</th> <th data-bbox="1091 501 1347 533">Proton part number</th> </tr> </thead> <tbody> <tr> <td data-bbox="756 539 893 571">DeviceNET</td> <td data-bbox="1139 539 1299 571">00043MC006</td> </tr> <tr> <td data-bbox="756 577 893 609">PROFIBUS</td> <td data-bbox="1139 577 1299 609">00043MC022</td> </tr> <tr> <td data-bbox="756 616 893 647">PROFINET</td> <td data-bbox="1139 616 1299 647">00043MC031</td> </tr> <tr> <td data-bbox="756 654 893 685">EtherNet/IP</td> <td data-bbox="1139 654 1299 685">00043MC005</td> </tr> </tbody> </table>	Protocol	Proton part number	DeviceNET	00043MC006	PROFIBUS	00043MC022	PROFINET	00043MC031	EtherNet/IP	00043MC005	
	Protocol	Proton part number										
	DeviceNET	00043MC006										
	PROFIBUS	00043MC022										
PROFINET	00043MC031											
EtherNet/IP	00043MC005											

## STANDS AND GUARDS

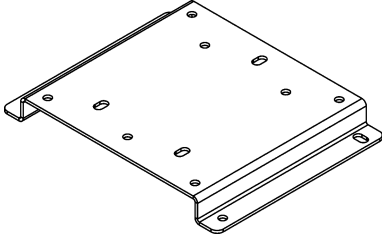
<b>Base Plate</b>	
	<ul style="list-style-type: none"> <li>• For securing a SL/SLR mini gauge to a mounting surface.</li> </ul>
Proton part number	00050MC042

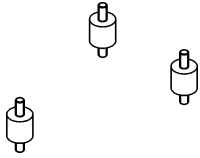
<b>Vibration reducing kit</b>	
	<ul style="list-style-type: none"> <li>• For use with the above Base Plate (00050MC042) in high-vibration environments.</li> </ul>
Proton part number	00050MC043

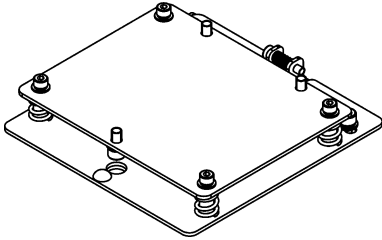
<b>3D Adjuster Plate</b>	
	<ul style="list-style-type: none"> <li>• For use with the above Base Plate (00050MC042) for precision alignment of the SL/SLR mini gauge to the measured object.</li> <li>• Provides <math>\pm 3^\circ</math> of roll and yaw adjustment.</li> </ul>
Proton part number	00050MC044

**Laser Protection Tube for SL/SLR mini 1220**

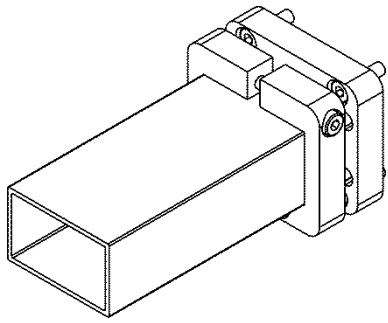

- Enclosure of the laser beam to within 10mm of the object for laser safety and harsh environments.

Proton part number

00050MC033

**Laser Protection Tube for SL/SLR mini 3060**

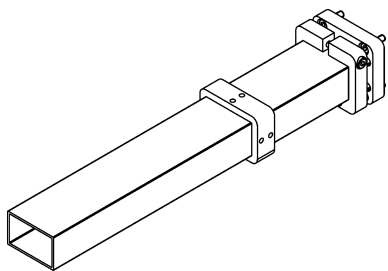

- Enclosure of the laser beam to within 10mm of the object for laser safety and harsh environments.

Proton part number

00050MC037

**PROTECTION**

**Air wipe**

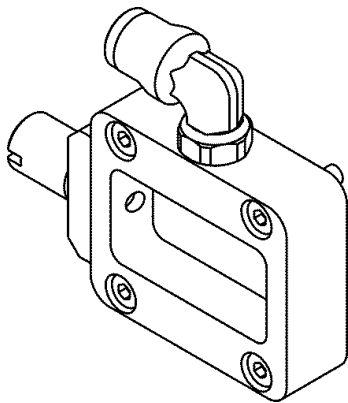

- High-efficiency, air-wiped protection window for dusty/steamy environments with a quick-change window release mechanism.
- Provides an 8 mm push fit tube fitting to connection to a clean air source.

Proton part number

00050MC034

Air quality must meet or exceed ISO 8573.1:2001 Class 1.3.1 (solids.water.oil):

Specification	Maximum	Units	Class
0.1 - 0.5 µm solid particle count	100	/ m <sup>3</sup>	1
0.5 - 1 µm solid particle count	1	/ m <sup>3</sup>	
1 - 5 µm solid particle count	0	/ m <sup>3</sup>	
Water vapour pressure dew point	-20	°C	3
Oil aerosol and vapour	0.01	mg / m <sup>3</sup>	1

## COOLING

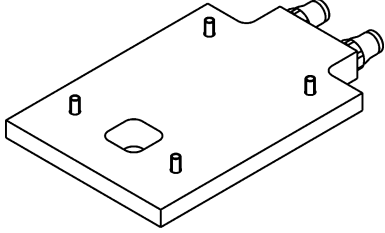
Cooling Plate	
	<ul style="list-style-type: none"><li>• Air or water cooled plate for installation between the gauge and mounting surface.</li><li>• For use in ambient temperatures up to 60°C.</li></ul>
Proton part number	00050MC031

# INSTALLATION



## PRECAUTIONS

### Operating and storage temperature

Specification	Minimum	Typical	Maximum	Units
Operating temperature	+5		+45	°C
Storage temperature	0		+45	°C

- Do not store or operate the gauge in temperatures outside of the specified ranges.
- Do not install the gauge near high temperature surfaces or objects which may cause it to overheat.
- Storage or operation of the gauge outside the specified temperature range may result in degraded measurement accuracy, malfunction or damage to the gauge.
- All gauges are fitted with internal temperature sensors which will permanently log any over-temperature condition that invalidates the warranty.

### Protect from impact

		
<b>Fragile</b>	<b>Do not drop</b>	<b>Protect from impact and mechanical shock</b>

- The gauge contains delicate optical and electronic assemblies and must never be dropped or struck by other objects.
- Only install the gauge on its mounting/stand when all machining, assembly and transportation of the mounting/stand has been completed.
- Do NOT strike, move or perform machining operations on the mounting/stand with the gauge installed.
- Damage incurred by the gauge as a result of impact, mechanical shock or rough handling is NOT covered by the manufacturer's warranty.

### Do not open or disassemble

- The gauge contains no user serviceable components.
- Loosening the gauge screws or removing its cover will invalidate the gauge warranty.
- Damage to or removal of any of the anti-tamper stickers will invalidate the gauge warranty.
- The gauge is factory-purged with dry nitrogen gas to prevent condensation on the internal optics; opening of the gas purge ports (indicated below) will invalidate the gauge warranty.

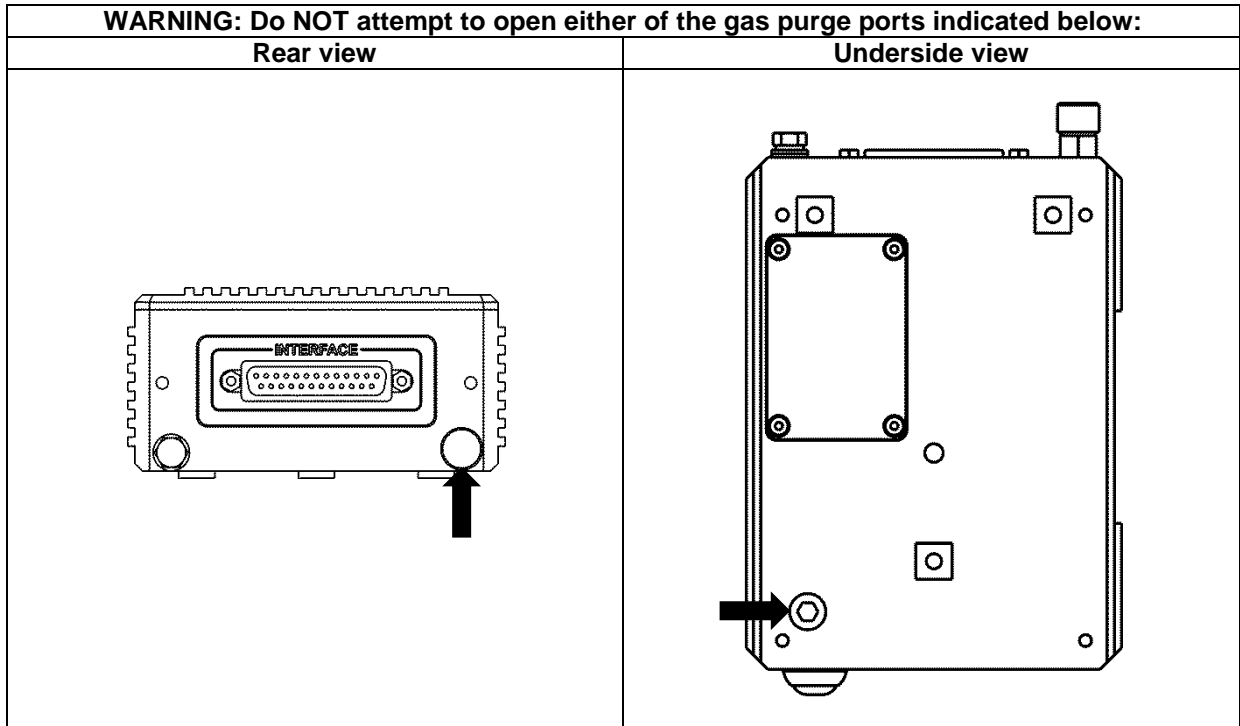



**Periodic maintenance**

- The physical condition of the gauge, optional accessories and connecting cables should be checked periodically; if any damage is suspected, then the unit should be taken out of service for inspection and repair or replacement of damaged parts.

**Laser radiation hazard**

- This product emits class 3B laser radiation; do not view the laser beams emitted by the gauge either directly or by specular reflection.
- For all class 3B laser devices, the safety measures below MUST be provided. Some measures are the responsibility of the device manufacturer (Proton Products), whilst other measures are the responsibility of the end-user.
- For further information on laser safety, please refer to European standard BS EN 60825-1:2007 “Safety of laser products; Part 1: Equipment classification, requirements and user’s guide”.

Safety Measure	Description	Provided by
Laser Safety Officer	A Laser Safety Officer (LSO) must be appointed by the end-user organisation and is responsible for ensuring that both the equipment and staff comply with laser safety regulations.	End-user
Laser safety training	The end-user organisation must provide appropriate laser safety training for all operators and maintenance personnel working in close proximity to the gauge.	End-user
Laser enable key-switch	A key-switch to disable the laser diode should be wired to the LSR_EN input. The laser safety officer should be responsible for the key and must withhold it during system maintenance or if the system fails to comply with laser safety regulations.	End-user
	A laser enable key-switch is provided on the optional PSU-BOB-mini.	Proton
Contain and terminate beam path	Terminate the laser beams at the end of their useful length (behind the measured object) with a beam block.	End-user
	Contain laser beam paths with laser guards which have closure switches wired to the SHUT_EN input so that the laser shutter is closed	

Safety Measure	Description	Provided by	
	if any guard is opened.  Do NOT permit the laser beams to be directed into open space.		
Prevent specular (mirror-like) reflections	Never direct the laser beams at specular (mirror-like) reflectors.  Remove all reflective objects such as jewellery or wristwatches before working near the laser beams.	End-user	
Emission indicator	Illumination of the "LASER" LED on the gauge indicates laser emission.	Proton	
	An external laser emission warning light may be triggered by the SHUT_ST output.	End-user	
Laser shutter switch	The switch to the side of the laser window opens or closes the laser shutter which blocks laser emission.	Proton	
	If the gauge is to be mounted in an inaccessible location, then this switch should be set to the open position and a remote, external laser shutter switch wired to the SHUT_EN input.	End-user	
Laser protection eyewear	Laser protection eyewear rated with the Optical Density (OD) rated for Class 3B lasers must be worn whenever there is a risk of eye exposure to the laser, for example during gauge alignment (see the "Laser Safety Parameters" section for information on laser wavelength, power and power densities).	End-user	
Laser warning signs	Class 3B laser warning signs must displayed in the working area; precautions on the warning signs must be followed.	End-user	
	<b>Example class 3B laser warning signage:</b>		
	<b>US standard</b>		<b>European standard</b>
			

### Optical windows

- Do not allow smoke, water, steam, dust or other debris to come into contact with any of the optical window.
- Obstruction of the optical window may degrade measurement accuracy or inhibit measurement.
- If the optical window appears to be damaged or misaligned, then the unit should be sent to a Proton Products authorised service agent for repair.
- If the optical window requires cleaning, then refer to the cleaning procedure detailed below to minimise the risk of scratching the windows.

## OPTICAL WINDOW CLEANING PROCEDURE

- The optical window is manufactured from anti-reflection coated optical glass; it must be treated with the same level of care as a high-performance camera lens.
- **Before inspecting or cleaning the optical window, ensure that the gauge is powered off, the LSR\_EN key-switch is locked out and no laser light is emitted.**

Required items	Notes
Small blower brush	Such as the type used to remove dust from camera lenses.
Lens cleaning tissues or micro-fibre lens cleaning cloth	Do NOT use facial tissues as these can scratch delicate optics.
Lens cleaning solution	Such as the type specified for cleaning camera lenses.

1. Use the small blower brush to remove any visible dust on the optical window.
2. Apply a few drops of lens cleaning solution to a fresh lens cleaning tissue or a clean micro-fibre lens cleaning cloth.
3. Gently wipe the optical window from the centre outwards; apply only light pressure to the tissue or cloth when wiping the optical window.
4. Repeat as necessary with fresh tissues or a clean section of cloth until the optical window is clean and free of all smears and smudges.

## INSTALLATION SEQUENCE

Unpack the gauge and check for missing accessories and shipping damage.

Mechanical installation:

1. Mount the gauge securely either on a user supplied mount or on an optional Proton Products mounting plate.

Electrical installation:

1. Install earth connections.
2. Connect the gauge to an optional Proton Products PSU-BOB mini power supply and breakout box.
3. Install laser safety connections (laser enable, shutter enable and shutter status).
4. Install communications interface connections (RS-232, Ethernet or optional PROFIBUS, PROFINET, EtherNet/IP or DeviceNET).
5. Install electrical interface connections (logic inputs, logic outputs, pulse outputs) using the optional Proton Products PSU-BOB mini breakout box or terminal strip.
6. Connect a PC installed with the PCiS\_SLmini software to the gauge via the RS-232, Ethernet or optional PROFINET or EtherNet/IP communications interface.
7. Configure the gauge using the PCiS\_SLmini software.



## MECHANICAL INSTALLATION

### Stand-off distance and depth-of-field

- For best accuracy, locate the measured object at the specified stand-off distance to the gauge.
- Speed and length measurement is possible for objects located away from the specified stand-off distance but still within the depth-of-field; however the measurement accuracy may be degraded by the reduced signal strength.

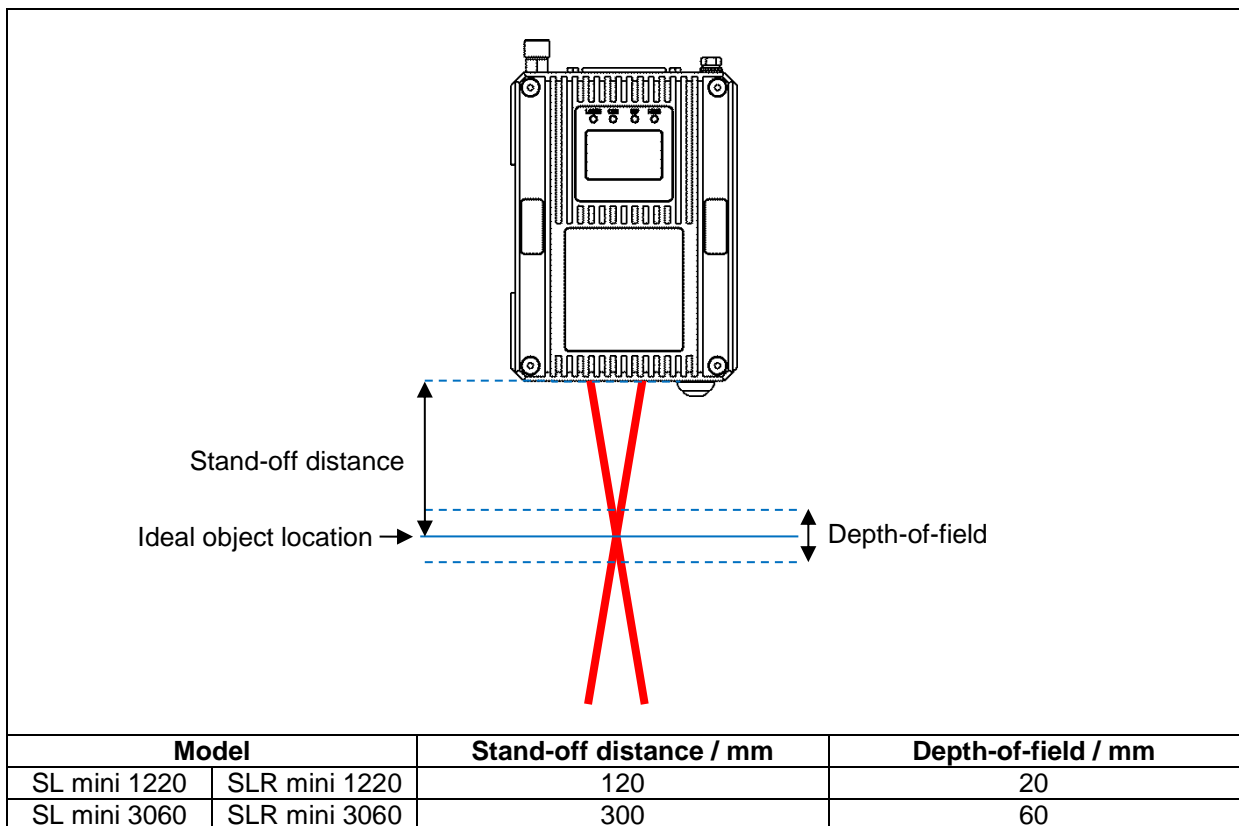

## Object stabilisation

For accurate speed and length measurements, the distance between the measured object and the gauge must be kept constant; the measured object must be guided to prevent flutter:

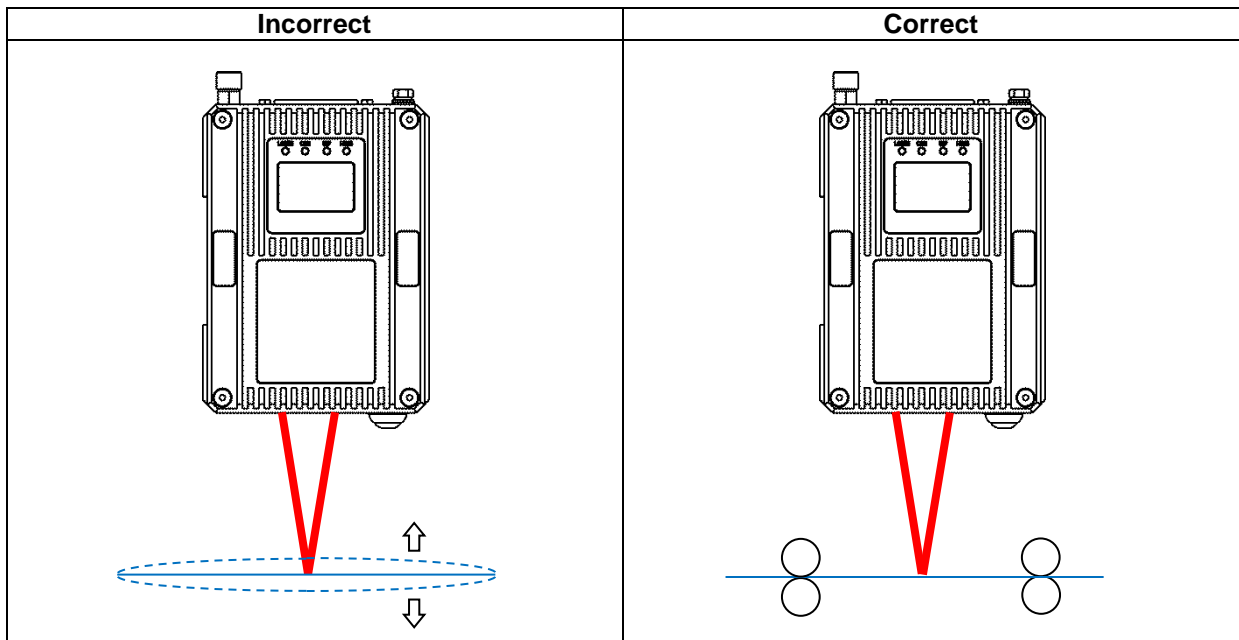

The end-user must provide suitable mechanisms for guiding and stabilising the motion of the measured object.

## Optical alignment

Non-perpendicular alignment of the speed and length gauge to the measured object will degrade measurement accuracy; it is recommended the gauge is installed and aligned by technicians with metrology experience who understand the implications of even a small angular misalignment.

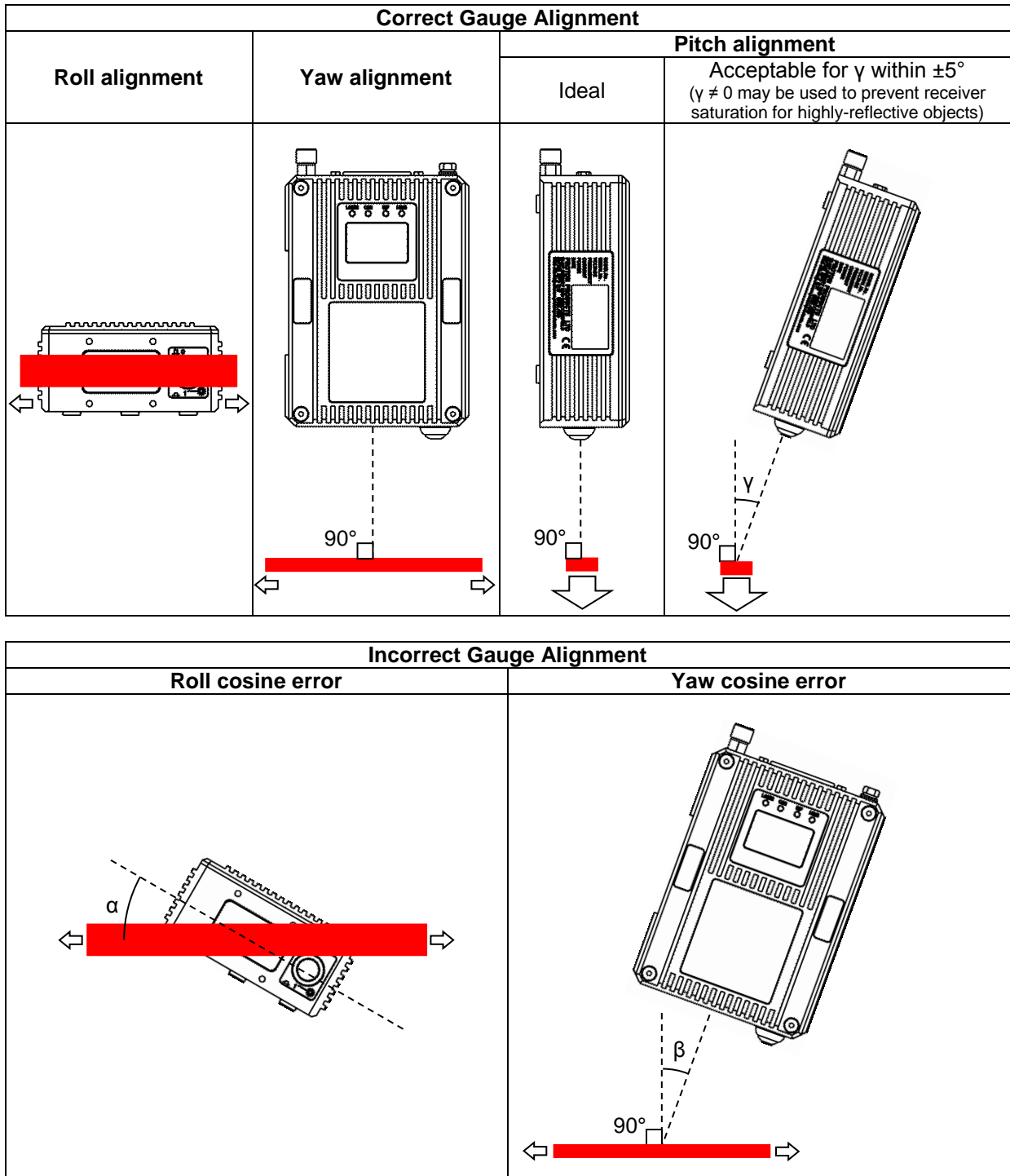

**Compounded roll and yaw cosine error**

$$\text{Measured speed} = (\text{True object speed}) \times \cos(\alpha) \times \cos(\beta)$$

<b>Error angle <math>\alpha</math> or <math>\beta</math> / degrees</b>	<b><math>\cos(\alpha)</math> or <math>\cos(\beta)</math></b>	<b>Measurement error / %</b>
0	1.000000	0.000
0.25	0.999990	-0.001
0.50	0.999962	-0.004
0.75	0.999914	-0.009
1.0	0.999848	-0.015
2.0	0.999391	-0.061
3.0	0.998630	-0.137
4.0	0.997564	-0.244
5.0	0.996195	-0.381
10	0.984808	-1.519

# MEASUREMENT DIRECTION

## SL MINI UNIDIRECTIONAL SPEED AND LENGTH GAUGE

The unidirectional SL mini speed and length gauge interprets motion in either direction as a positive speed and an increase in length, thus correct length accumulation requires that the object must only move in one direction (reverse motion will incorrectly cause the length to increment, not decrement).

Length measurements during line stoppage may exhibit a positive error due to microscopic vibration of the object; hence it is recommended that the “Length hold” function on the SL mini logic input is activated by the line controller when the line is stationary to temporarily suspend speed measurement and length accumulation.

For production lines that require correct length accumulation during direction reversals or line stoppage (without using the “Length hold” function), it is recommended that the SLR mini is used.

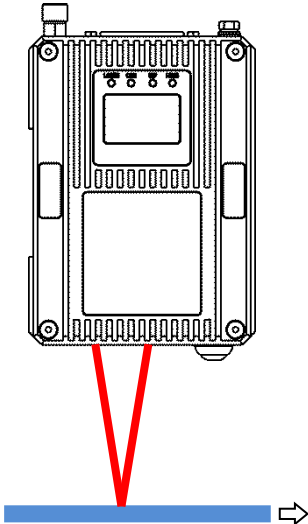
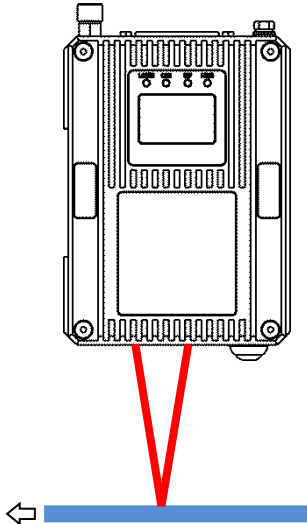
SL mini			Left to right		Right to left	
<b>Object motion direction</b>						
			<b>Count</b>	<b>Input DW12.12</b>	<b>Rev Direction logic input</b>	<b>Speed</b>
[Up]	[0]	Inactive	Positive	Incrementing	Positive	Incrementing
Down	1	Active	Negative	Decrementing	Negative	Decrementing

[ ] factory-default setting

## SLR MINI BIDIRECTIONAL SPEED AND LENGTH GAUGE

The bidirectional SLR mini speed and length may be used for production lines that exhibit bidirectional motion and line stoppage.

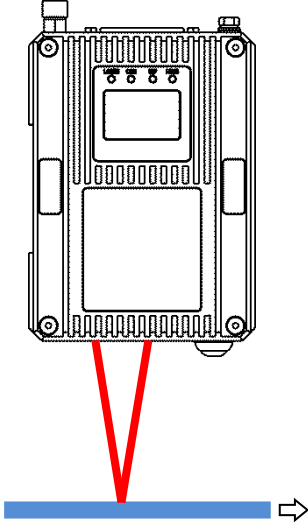
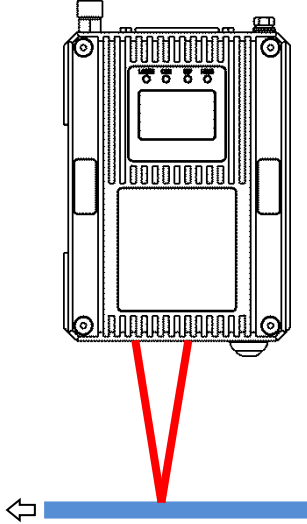
SLR mini			Left to right		Right to left	
<b>Object motion direction</b>						
			<b>Count</b>	<b>Input DW12.12</b>	<b>Rev Direction logic input</b>	<b>Speed</b>
[Up]	[0]	Inactive	Negative	Decrementing	Positive	Incrementing
Down	1	Active	Positive	Incrementing	Negative	Decrementing

[ ] factory-default setting

### Mechanical mounting

It is preferable for the gauge to be mounted in isolation from the machine or production line using a precision base plate fitted to a mounting arm (if this is not possible then the gauge must be mounted on rubber vibration isolation mounts). The mounting arm should be kept as short as possible to avoid vibration or twisting.

- Please see the dimensional drawings for mounting hole locations.
- Three M5 tapped holes are provided in the base of the gauge; select appropriate length screws which do not bottom out in these holes.

Specification	Minimum	Typical	Maximum	Unit
Mounting surface flatness (machined flat and even)			0.15	mm
M5 mounting hole depth (do not allow bolts to bottom out)			6	mm
M5 mounting bolt torque			6	Nm

## ELECTRICAL INSTALLATION

### Earth connection

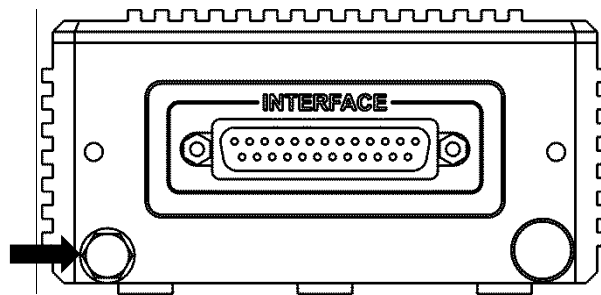

Connector type: M5 bolt

- An earth wire of at least 6mm<sup>2</sup> must be attached via a crimp on ring terminal to the dedicated M5 earth bolt on the case of the gauge.
- Do not rely on the mounting bolts to provide a reliable earth path.
- If a height stand is used then it must also be earthed via its own dedicated earth wire.
- All earth wires should be kept as short as possible.

### Shielded Cables

- Use shielded cable for all signal connections.
- Ensure that all cable shields are correctly clamped and electrically connected to their connectors and metal connector shells at both ends.
- Ensure that the shields of cables connecting to the end user's equipment are clamped to earth at their destination.

## LASER ENABLE

- The laser enable input is provided for compliance with laser safety regulations.
- The laser diode in the gauge may be energised only if the “LSR\_EN” pin (pin 14) is connected (via an external user-supplied switch contact) to any one of the “DGND” pins (pins 2, 15, 24).
- The gauge requires a few minutes for the laser temperature to stabilise and for valid measurement after “LSR\_EN” is connected to “DGND”. For this reason, it is recommended that the laser enable input is connected to a safety interlock that is active infrequently, such as a maintenance lock-out key switch.
- Safety interlocks that are frequently activated and require the gauge to immediately resume measurement upon deactivation (such as a machine guard door) should be connected to the shutter enable input (“SHUT\_EN”) described in the next section.

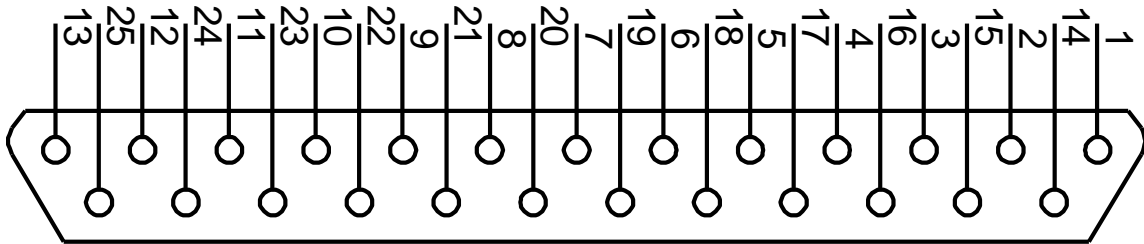

Connector type: DB25 female (socket)

Functional group	Pin	Designation	Description	Notes	
Shield	S	Shield	Shield	Connect to cable and plug shields	
Power supply and ground	25	+24V SUPPLY	+24V power supply		
	2	DGND	Power supply and signal ground (0V)		
	15				
	24				
Laser enable	14	LSR_EN	Laser enable	<b>Connection</b>	<b>Laser diode state</b>
				Open	Off (no emission)
				Connected to DGND	On (emission)

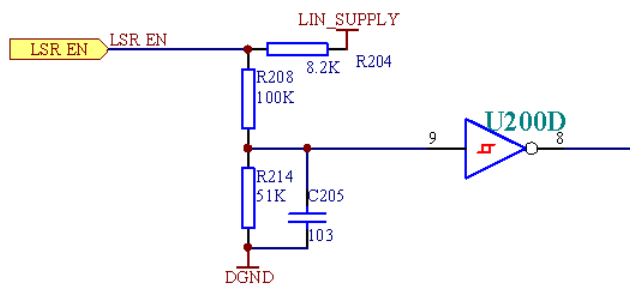



## SHUTTER CONTROL SWITCH, SHUTTER ENABLE INPUT AND SHUTTER STATE OUTPUT

The shutter control switch (located on the front of the gauge), the shutter enable input (SHUT\_EN) and shutter status output (SHUT\_ST) are provided for compliance with laser safety regulations.

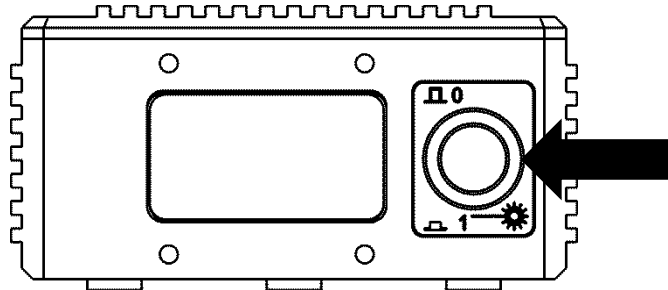

- The SHUT\_EN input and the shutter control switch operate in conjunction as follows:

SHUT_EN input	Shutter control switch position	Shutter state	Laser output
Open	O	Closed	Blocked
Open	I	Closed	Blocked
Shorted to DGND	O	Closed	Blocked
Shorted to DGND	I	Open	Emitting

- The shutter control switch and SHUT\_EN input blocks laser beam emission without switching off the laser diode, thus no warm up time is required when the shutter is opened and the gauge may be used immediately for measurements.
- The SHUT\_EN input is intended for connection to a safety interlock switch that may be frequently opened, such as on a machine guard or laser safety shield.
- The SHUT\_ST output is electrically independent of the SHUT\_EN input; the SHUT\_ST signal is taken directly from an optical sensor in the path of the shutter, thus it indicates the shutter state even in the event of shutter actuator failure.

### SHUT\_EN input electrical specifications

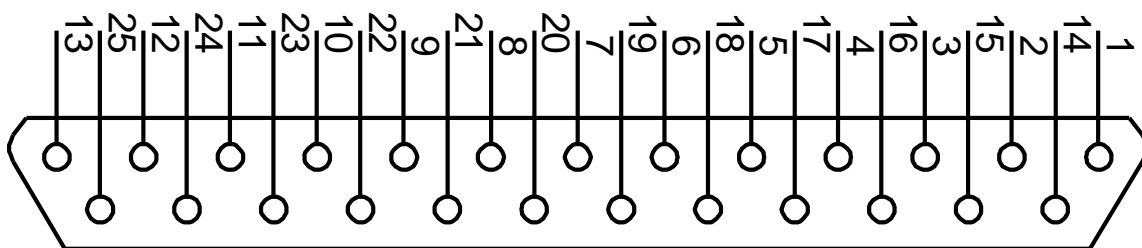

Connector type: DB25 female (socket)

Functional group	Pin	Designation	Description	Notes		
Shield	S	Shield	Shield	Connect to cable and connector shields		
	2 15 24	DGND	Power supply and signal ground (0V)			
Shutter control	13	SHUT_EN	Shutter control input	<b>Connection</b>	<b>Shutter</b>	<b>Laser</b>
				Low state (logic 0) / connected to DGND	Open	Emitting
				High state (logic 1) / unconnected	Closed	Blocked

- The SHUT\_EN input is NOT isolated from earth.
- The input is internally pulled up to +15V via an 8.2kΩ resistor and will default to the high state if left unconnected.
- The input will source a minimum current of 3mA when externally pulled down to the low state.

Specification	Minimum	Typical	Maximum	Units
Low state (logic 0) input voltage			3	V
High state (logic 1) input voltage	10.5			V
Absolute input voltage	-30		30	V
Low state source current	3			mA

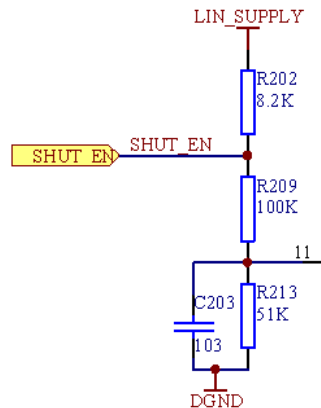

### SHUT\_ST output electrical specifications

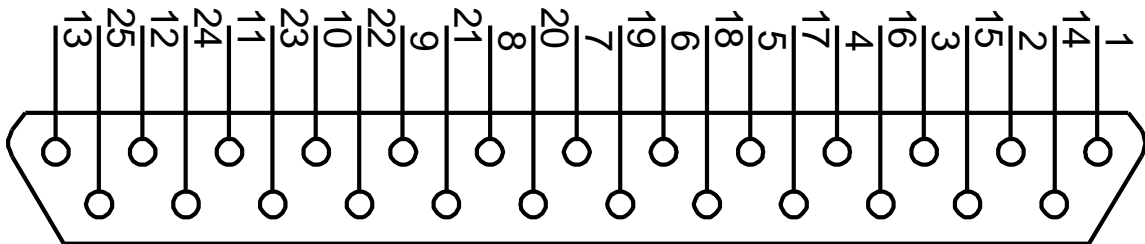

Connector type: DB25 female (socket)

Functional group	Pin	Designation	Description	Notes		
Shield	S	Shield	Shield	Connect to cable and connector shields		
Power supply and ground	25	+24V SUPPLY	+24V power supply			
	2	DGND	Power supply and signal ground (0V)			
	15					
Shutter control	12	SHUT_ST	Shutter status output	<b>Signal</b>		
				Pulled down to DGND	<b>Shutter</b>	<b>Laser</b>
				Floating	Open	Emitting
				Closed	Blocked	

- The SHUT\_ST output is NOT isolated from earth.
- The SHUT\_ST output must NOT be used to directly drive high-current or inductive loads.
- It is recommended that the SHUT\_ST output is used to drive an opto-isolated solid-state relay.

Specification	Minimum	Typical	Maximum	Units
Logic output to DGND voltage			+25	VDC
Current			0.1	A

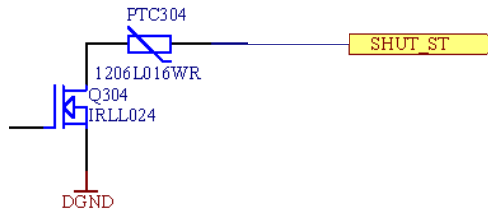

## POWER SUPPLY

Specification	Minimum	Typical	Maximum	Units
Power supply voltage*	15	24	28	VDC
Power consumption			15	W

\*If a long power supply cable with a significant voltage drop is used, then ensure that the voltage at the gauge connector does not fall below the minimum value.

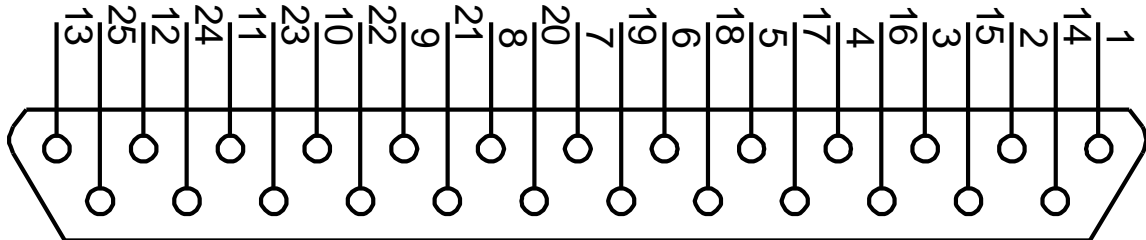

Connector type: DB25 female (socket)

Functional group	Pin	Designation	Description	Notes
Shield	S	Shield	Shield	
Power supply	25	+24V SUPPLY	+24V power supply	
	2	DGND	Power supply and signal ground (0V)	
	15			
	24			

### Powering on the gauge

The gauge has no power switch; as soon as power is applied it will power up and perform some self-tests. Measurement will begin after a warm-up period of a few minutes required for the temperature of internal components to stabilise.

### Powering off the gauge

The gauge has no power switch; it may be powered off by switching off or disconnecting the power supply to the unit.

# CONFIGURATION

The SL mini and SLR mini series of speed and length gauges may be configured using a PC running the PCIS\_SLmini software.

## PCIS\_SLMINI SOFTWARE PC SYSTEM REQUIREMENTS

Minimum processor	Pentium 300 MHz CPU compatible or higher
Minimum RAM	512 MB
Minimum free hard disk space	100 MB
Display resolution	1024 x 768
Operating system	Microsoft Windows XP / Windows 7 / Windows 8
Other requirements	100Base-TX Ethernet port or adapter card
	RS-232 port or USB port and USB to RS-232 adaptor cable
	Keyboard and mouse (for configuration and software installation)

## PCIS\_SLMINI SOFTWARE INSTALLATION

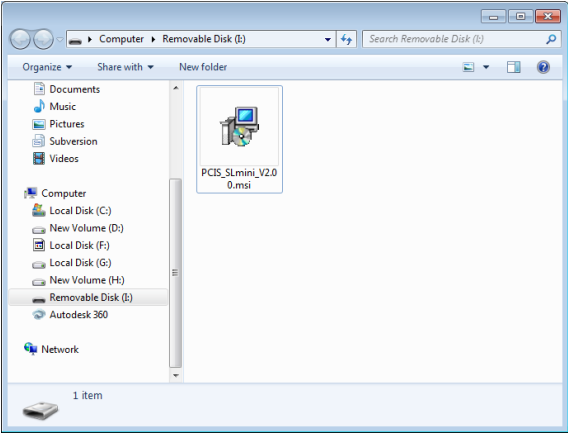
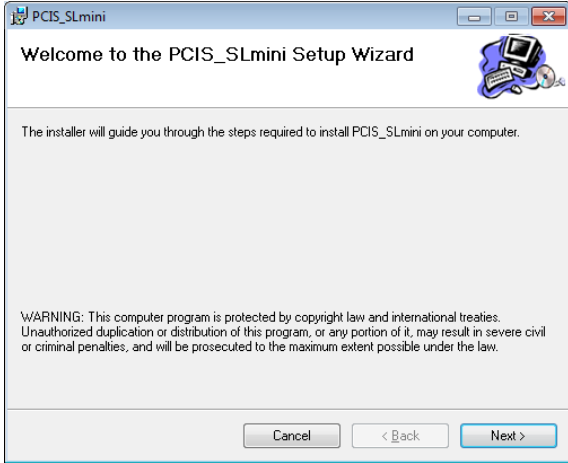
<b>1</b>	Double-click the “PCIS_SLmini_Vx.yy.msi” icon on the supplied USB flash memory drive (“x.yy” will depend on the software version).	<b>2</b>	Click “Next >” to proceed with the installation.
			

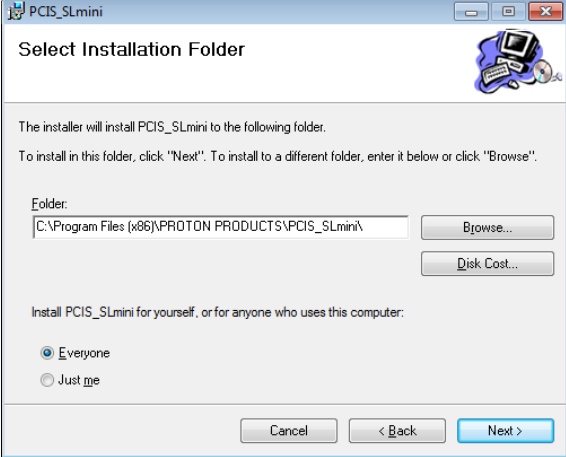
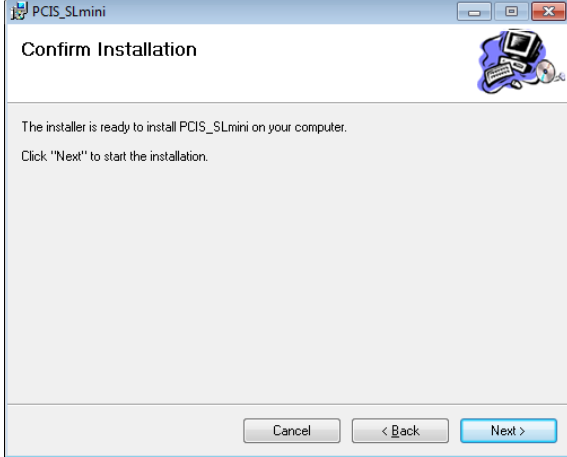
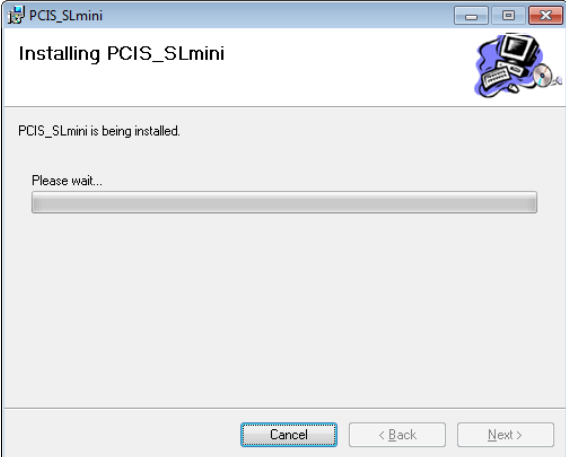
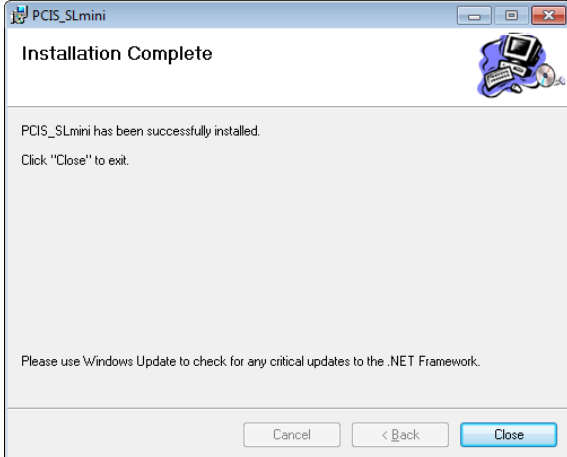
<p><b>3</b> If required, click “Browse” to select an alternative installation folder.</p> <p>If required, click “Just me” to limit access to this program to the current user.</p> <p>Click “Next &gt;” to proceed with the installation.</p>	<p><b>4</b> Click “Next &gt;” to proceed with the installation.</p>
	
<p><b>5</b> Wait for the installation to complete.</p>	<p><b>6</b> Click “Close” to finish installation.</p>
	

## CONNECTION AND SOFTWARE START UP

A PC running the PCiS\_SLmini software may be connected to the gauge using any one of the following communications interfaces:

- RS-232 (fitted as standard on all gauges).
- Ethernet (only available if NO other optional communications interface has been installed).
- EtherNet/IP (only available if the gauge has been installed with the optional EtherNet/IP communications interface)
- PROFINET (only available if the gauge has been installed with the optional PROFINET communications interface)

**Note:** For gauges communicating over either optional EtherNet/IP or PROFINET communications interfaces, only input and output parameters DW0 to DW31 are visible to the PCiS software.

The above communications interfaces may be directly accessed via the DB25 “INTERFACE” connector on the rear of the gauge or via a PSU-BOB mini connected to the “INTERFACE” port; for wiring information, please refer to the following sections in this manual:

- RS-232 Communications
- Ethernet Communications
- EtherNet/IP or PROFINET Communications

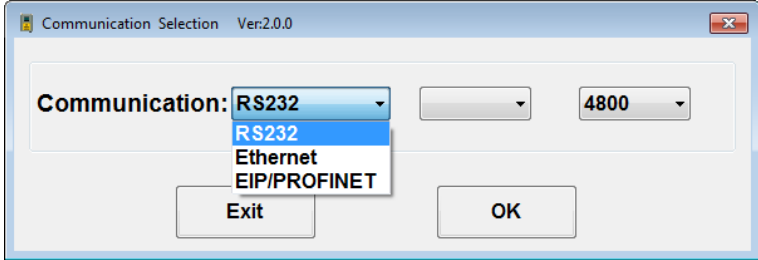
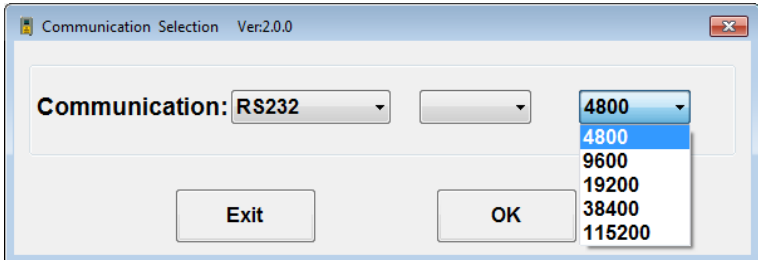
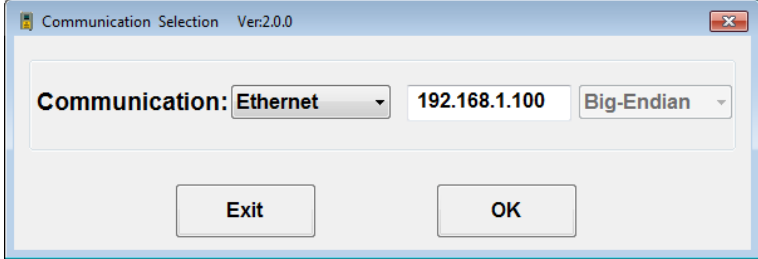
1	Run the PCIS_SLmini software by clicking on:
	
2	Select the interface type (choose from “RS232”, “Ethernet” or “EIP/PROFINET”) from the drop-down menu:
	
3a	If using the “RS232” interface, select the COM port on the PC to which the gauge is connected and the baud rate (choose from “4800”, “9600”, “19200”, “38400” or “115200”; the factory default is “9600”) from the drop-down menus:
	
3b	If using the “Ethernet” interface, enter the IP address of the gauge:
 <p style="text-align: center;">“EIP/PROFINET”</p>	

3c If using the “EIP/PROFINET” interface, enter the IP address of the gauge and select “Big-Endian” or “Little-Endian” data format (the factory-default is “Big-Endian”):

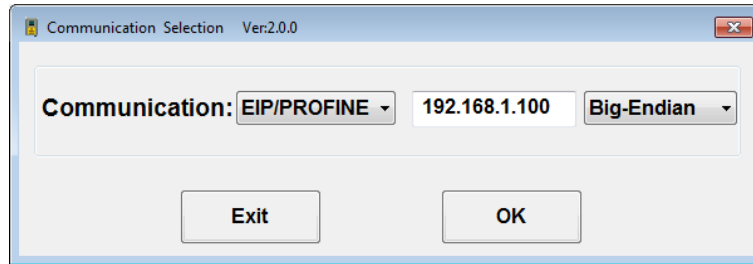

4 Click the “OK” button to proceed.

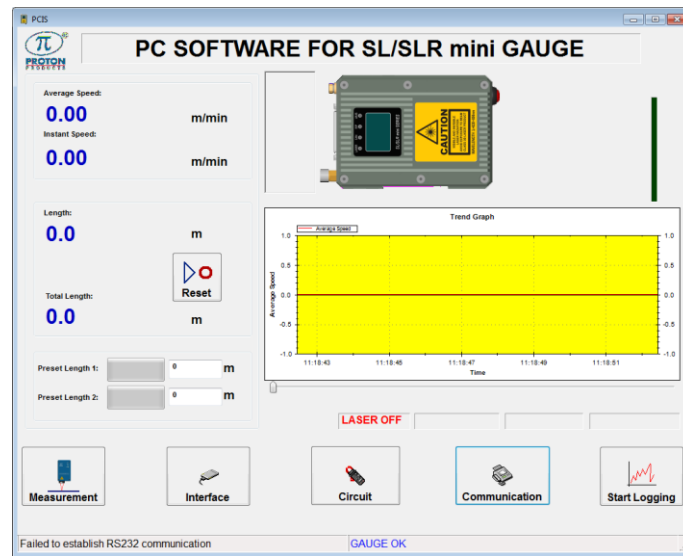



## WIFI CONFIGURATION

The WIFI function can be configured via the PCiS\_SLmini software after a PC connection is established with the gauge.

1 | Click the “Comms” button on the main page:

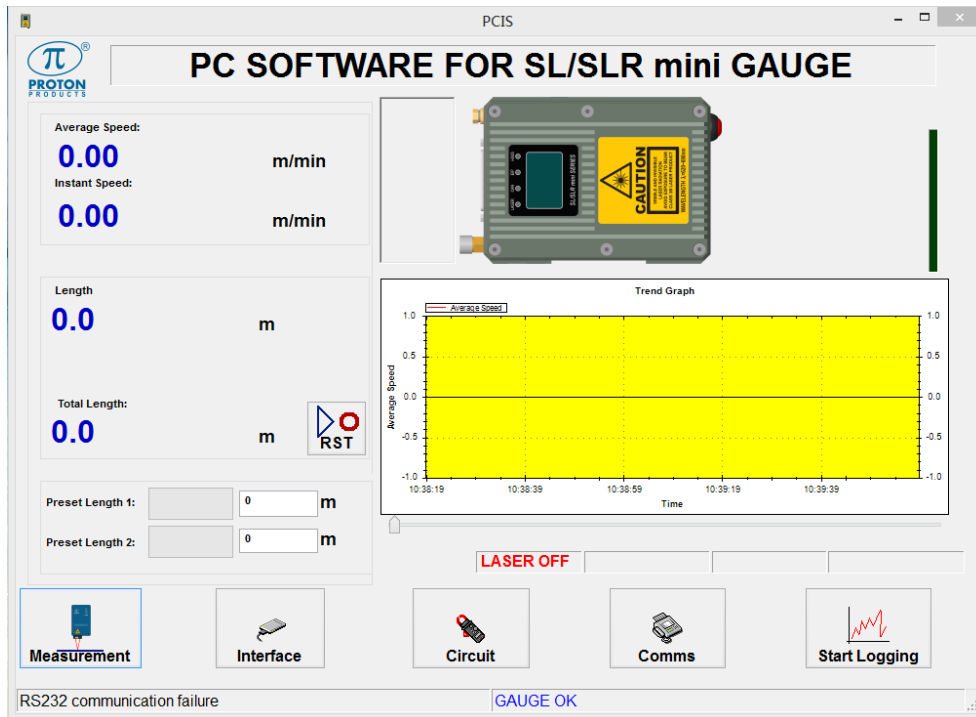

2 | When prompted to input a password, enter “65000” then click the “OK” button:

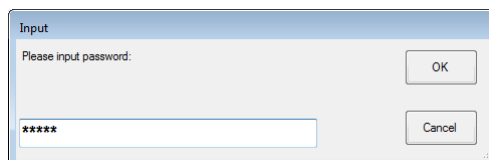

3 | Click the “WIFI” button on the Communication Setting page:

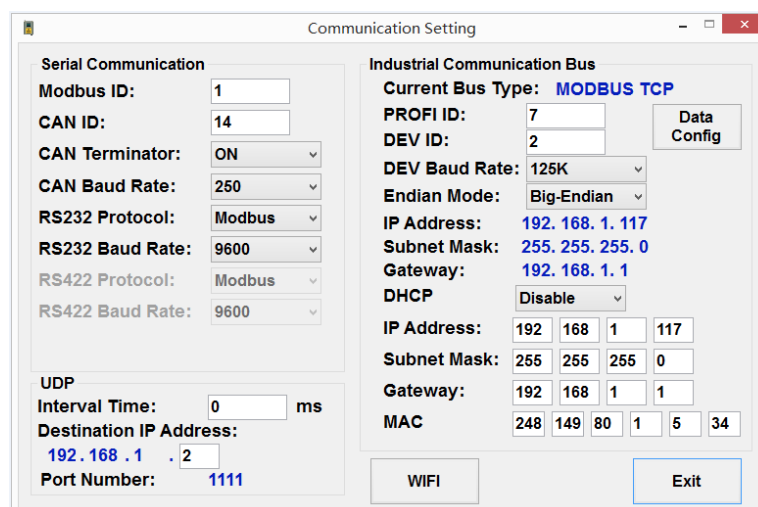

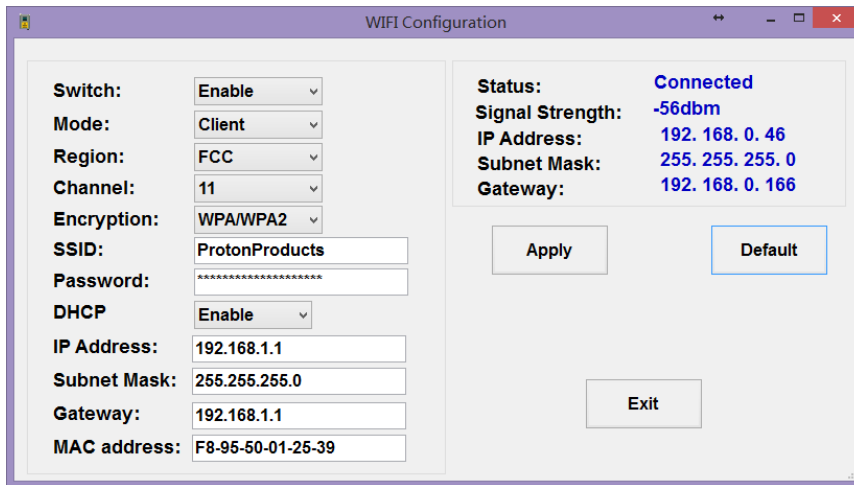

4 | Configure the WIFI interface as required then click the “Apply” button when complete.



Label	Value	Description
Switch	Enable	Switch on the WIFI function.
	Disable	Switch off the WIFI function.
Mode	Client mode	The gauge acts as a client device in client mode.
	AP mode	The gauge acts as an access point in AP mode.
Region	OTHER	Select the region where the gauge is located.
	ETSI	
	FCC	
	JAPAN	
Channel	1~11	Select the radio channel for the gauge.
Encryption	OPEN	Select the network encryption method.
	WPA/WPA2	
SSID	*****	Enter the SSID of the network.
Password	*****	Enter the password of the network.
DHCP	Enable	Select this option to enable the gauge to automatically acquire its IP address, subnet mask and gateway from a DHCP server on the network.
	Disable	Select this option to manually configure the gauge IP Address, subnet mask and gateway in the fields below.
IP Address	[192.168.1.1]	Enter the IP address assigned to the gauge.
Subnet Mask	[255.255.255.0]	Enter the subnet mask for the network.
Gateway	[192.168.1.1]	Enter the gateway IP address for the network.
MAC Address	xx-xx-xx-xx-xx-xx	Enter the physical MAC address of the WIFI chip.

\* [ ] indicates factory-default values.

**Note:** To restore the gauge to factory-default network settings, click the “Default” button. See the table above for the factory-default values.

The WIFI function can also be enabled or disabled manually using the physical hardware buttons on the gauge. To do this, first enter the WIFI interface configuration screen by long pressing  (the pause button) while the gauge is powering on. Then press  (the reset button) to enable or disable the WIFI function. Press the pause button to exit the WIFI interface configuration screen.

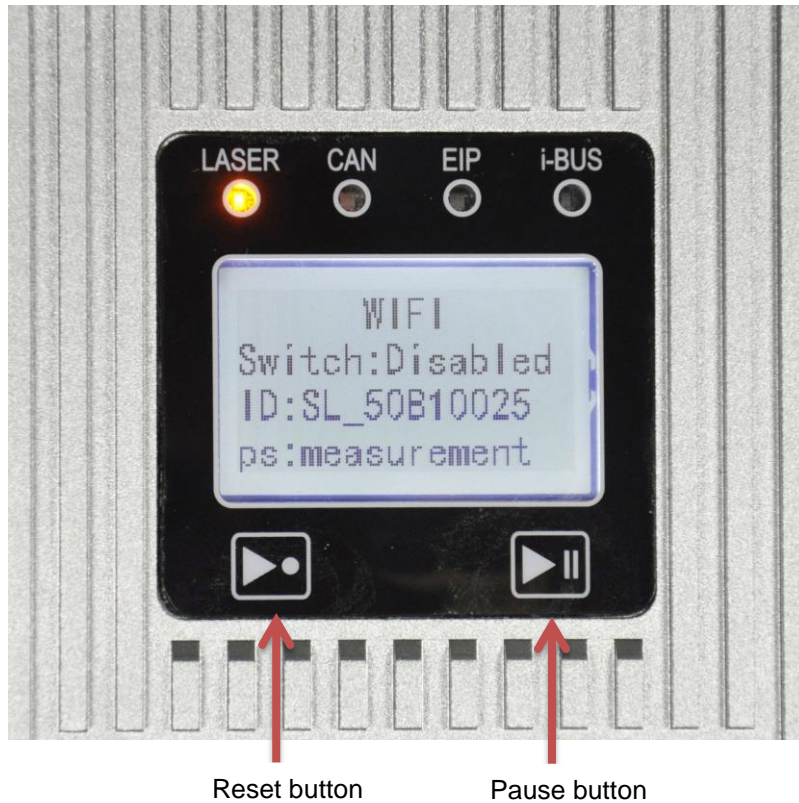

In the event of communication issues, it may be necessary to enable the Federal Information Processing Standards (FIPS) compliance on the PC connected with the gauge. To enable the FIPS compliance, please use the following procedure:

- 1 | Open the Status window for the PC's WIFI adapter and click the "Properties" button.



2 | Click the Advanced settings button on the Security tab.

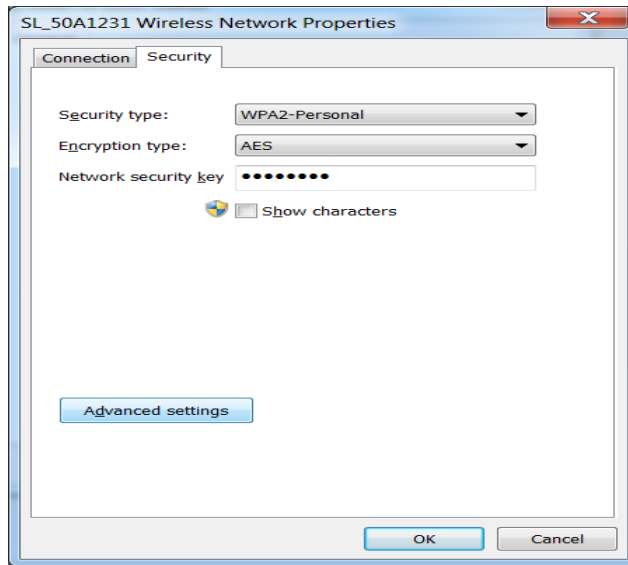

3 | Check the tick box next to "Enable Federal Information Processing Standards (FIPS) compliance for this network" then click the "OK" button.

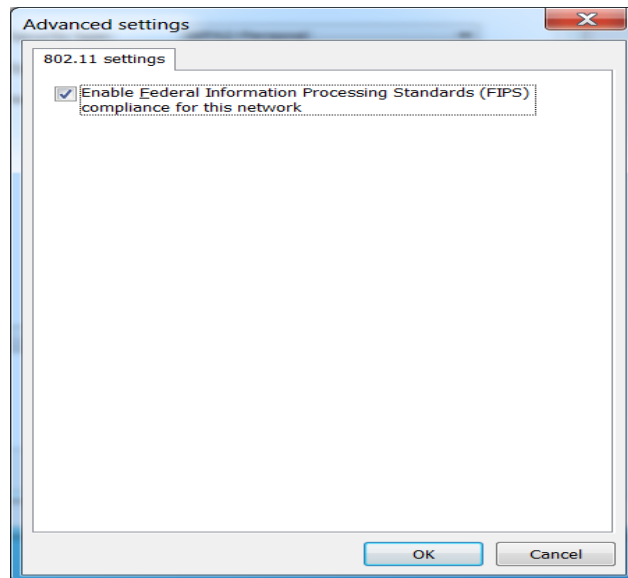

# PCIS\_SLMINI MAIN PAGE

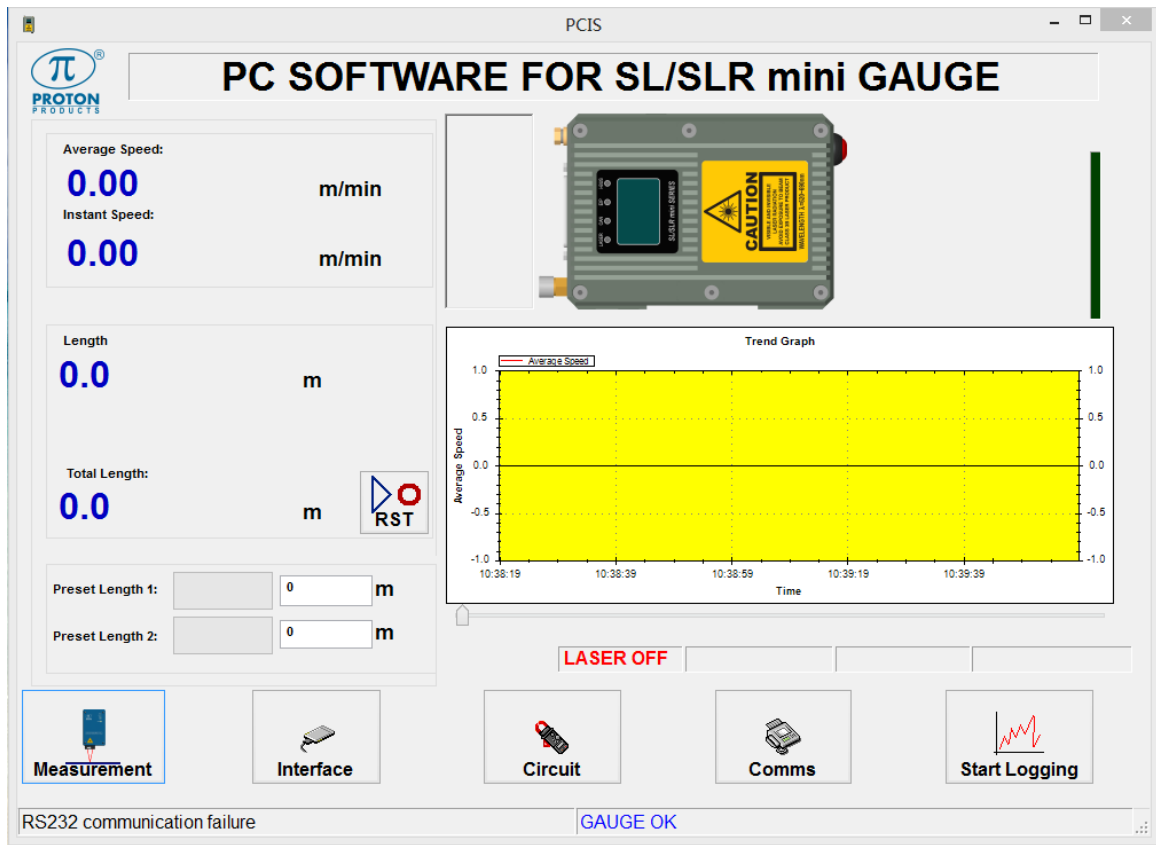

Label	Description	
Average Speed	Displays the time-averaged measured object speed.	
Instant Speed	Displays the instantaneous measured object speed.	
Length	<b>Normal mode</b>	Displays the measured length.
	<b>Batch mode</b>	Displays the measured length of the current segment.
Total Length	<b>Normal mode</b>	Displays the measured length (identical to "Length" above).
	<b>Batch mode</b>	Displays the total measured length of all segments.
Reset	Click this button to reset the measured "Length" and "Total Length" to zero.	
Preset Length 1	Click to enter "Preset Length 1" at which the corresponding logic output is activated.	
	The bar graph indicates the measured length relative to this preset.	
Preset Length 2	Click to enter "Preset Length 2" at which the corresponding logic output is activated.	
	The bar graph indicates the measured length relative to this preset.	

# TREND GRAPH

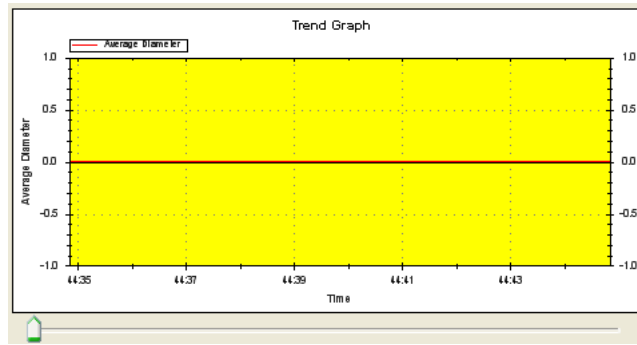

Drag the slider at the bottom of the graph to pan along the graph:

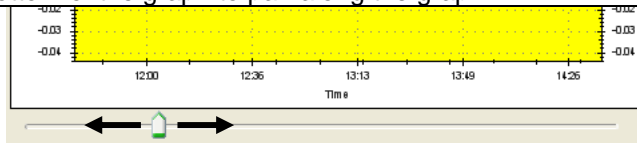

Click and drag to zoom in on the graph:

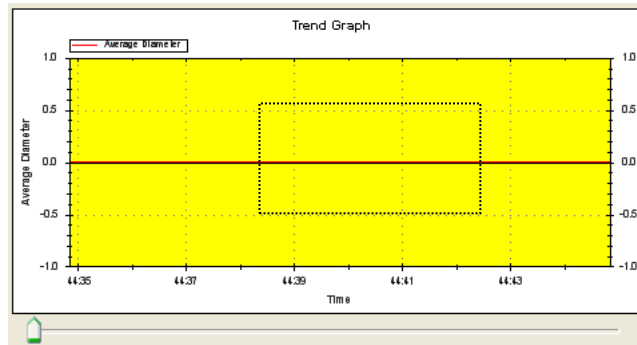

Double-click on the graph to open it in a larger window:

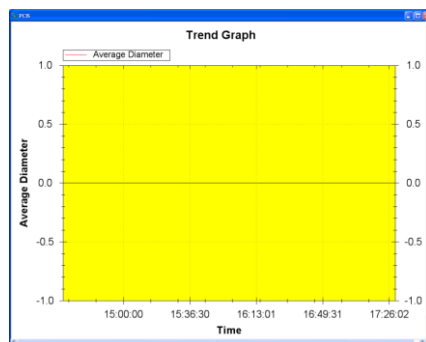

Double-click on the graph to return to the main page.

## Context menu

Right-click on the graph to open the context menu:

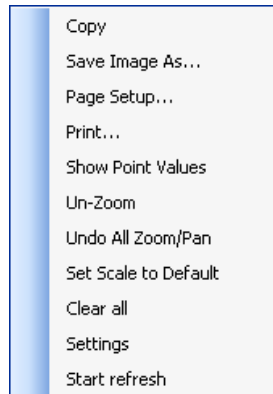

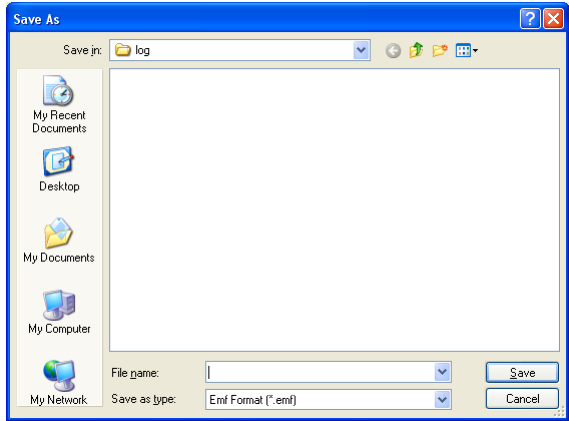
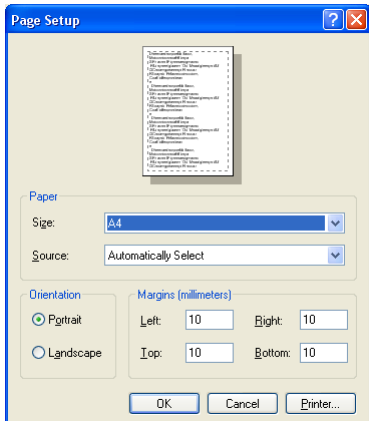
Field	Description
Copy	Copy the image of the graph to the clipboard (for subsequent pasting into other documents).
Save Image As...	<p>Save an image of the graph to a file:</p> 
Page Setup...	<p>Open the "Page Setup" dialog box for printing the graph:</p> 

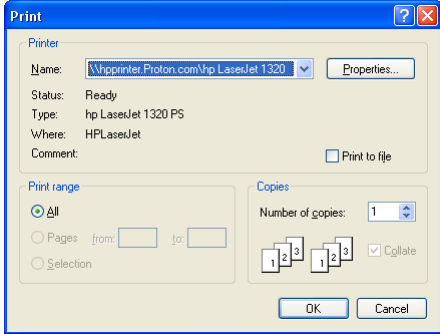
Field	Description	
Print...	<p>Open the "Print" dialog box for printing the graph:</p> 	
Show Point Values	Ticked      Show the value of the point on the graph under the cursor.	
	Un-ticked    Do not show the value of the point on the graph under the cursor.	
Un-Zoom	Return to the un-zoomed view of the graph.	
Undo All Zoom/Pan	Return to the un-zoomed, un-panned view of the graph.	
Set Scale to Default	Return to default scale settings.	
Clear all	Clear the current graph and begin plotting from the left side of the time axis.	
Settings	Open the graph settings dialog box (see below).	
Stop	refresh	Halt graph update.
Start		Resume graph update.

## Settings

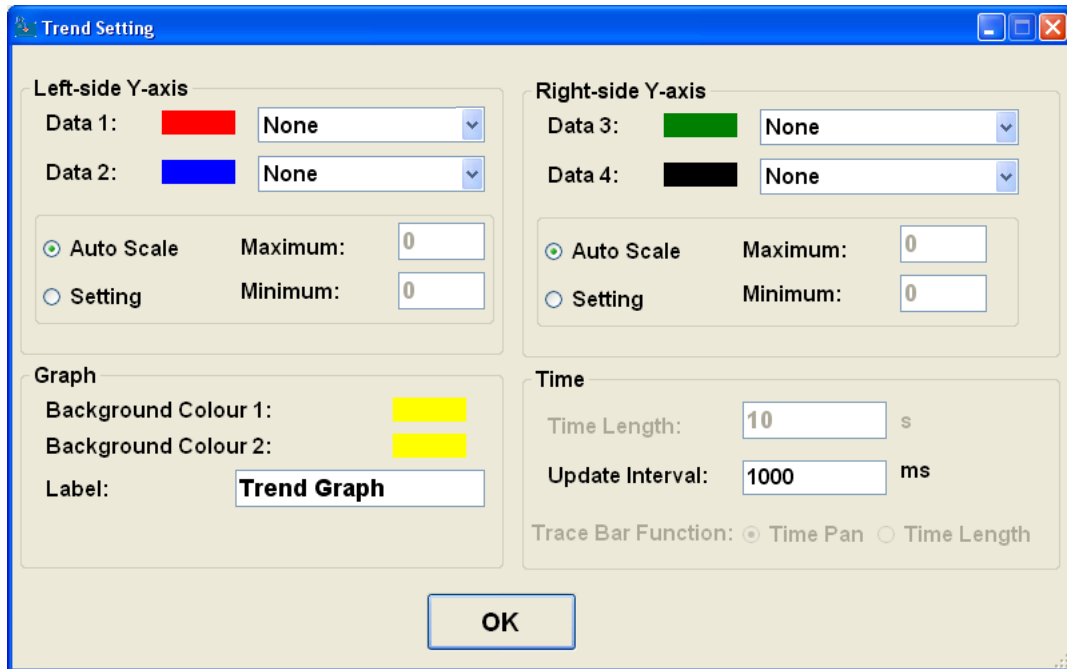

Click the "OK" button to return to the main page.



### Left-side Y-axis

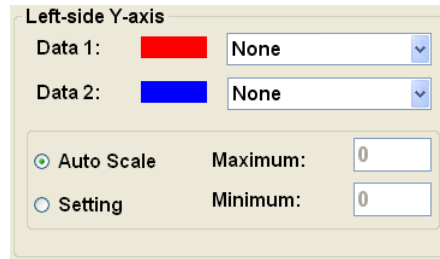

Field	Description
Data 1	Click on the drop down box to select the data plotted on this axis.
	Click on the coloured box to select the line colour.
Data 2	Click on the drop down box to select the data plotted on this axis.
	Click on the coloured box to select the line colour.
Auto Scale	Click to allow the software to automatically set the minimum and maximum values for this axis.
Setting	Click to manually set "Maximum" and "Minimum" values for this axis.
Maximum	Click to enter the maximum value for this axis.
Minimum	Click to enter the minimum value for this axis.

Clicking on "Data" or colour boxes will open the colour selection dialog:

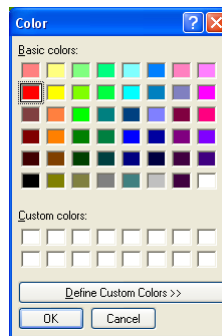

### Right-side Y-axis

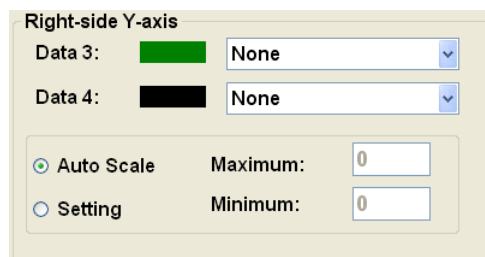

Field	Description
Data 3	Click on the drop down box to select the data plotted on this axis.
	Click on the coloured box to select the line colour.
Data 4	Click on the drop down box to select the data plotted on this axis.
	Click on the coloured box to select the line colour.
Auto Scale	Click to allow the software to automatically set the minimum and maximum values for this axis.
Setting	Click to manually set "Maximum" and "Minimum" values for this axis.
Maximum	Click to enter the maximum value for this axis.
Minimum	Click to enter the minimum value for this axis.

Clicking on “Data” or colour boxes will open the colour selection dialog:

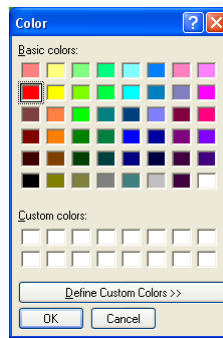

### Graph



Field	Description
Background Colour 1	Click on the coloured box to select the top left corner background colour for the graph; this colour will be graded across the graph to “Background Colour 2”.
Background Colour 2	Click on the coloured box to select the bottom right corner background colour for the graph; this colour will be graded across the graph to “Background Colour 1”.
Label	Click to enter a title for the graph.

Clicking on “Background Colour” colour boxes will open the colour selection dialog:

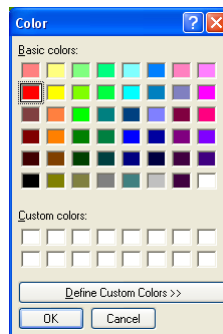

### Time

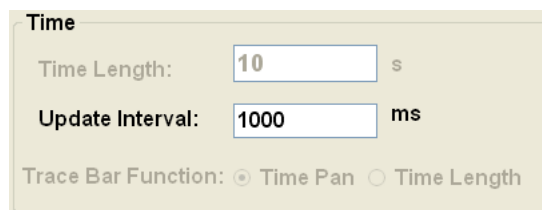

Field	Description
Update interval	Set the time interval at which data is updated on the graph; a shorter time interval will result in a more detailed graph, whilst a longer time interval is clearer at showing long-term trends.

# MEASUREMENT CONFIGURATION

Configuration via the PCiS\_SLmini software:

1 Click the “Measurement” button on the main page:

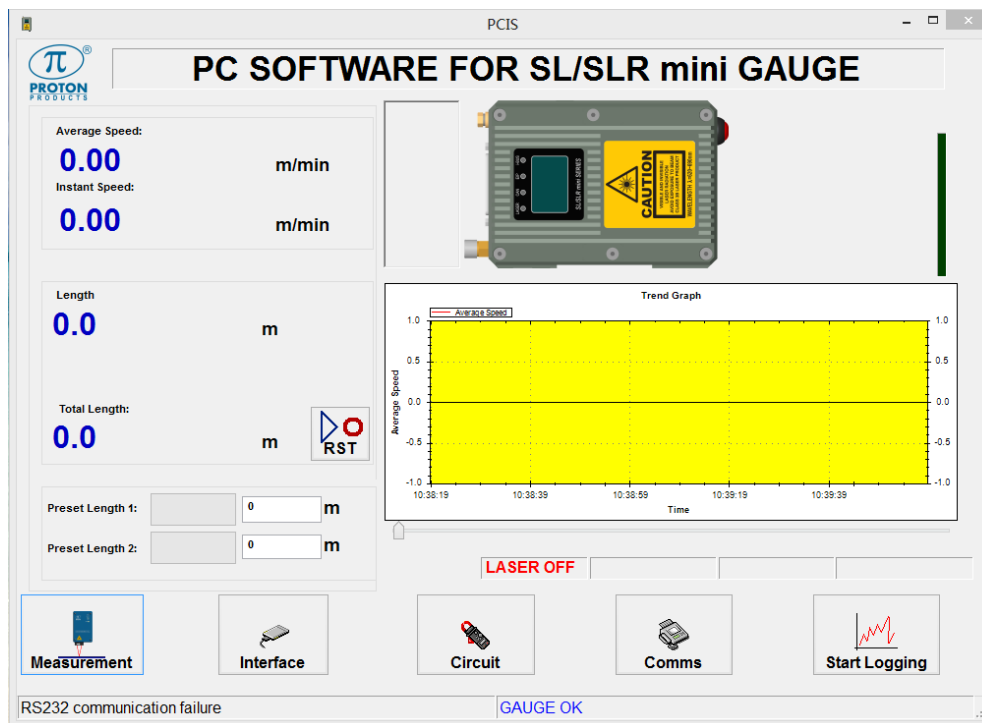

2 When prompted, enter 63000 for the password and click the “OK” button:

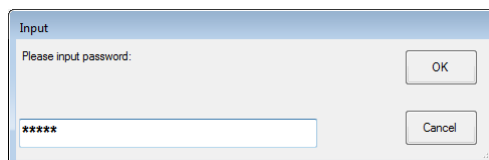

3 Configure the gauge as required and click the “Exit” button when complete:

The screenshot shows a software window titled "Measurement" with the following settings:

- Operation Mode: Normal
- Measurement Unit: m/min,m
- Length Speed Resolution: 0.1 & 0.01
- Speed Decimal Point: 0.000
- Length Decimal Point: 0.0000
- Object Detection: OFF
- SLR Object Detection Mode: DC Level
- Auto Reset When Object detected: OFF
- Object Detection Threshold: 0 %
- Length Auto Save: OFF
- Speed Averaging Time: 0 ms
- Hold Time: 0 ms
- Length Offset: 0.0 m
- Speed Compensation: 0.0000
- Minimum Speed Limit: 0.0 m/min
- Acceleration Limit: 0 m/min/s
- Reel Number: 0 (with a Reset button)
- Panel Key Button Switch: Enabled

Test section:

- Speed Mode: Normal
- Random:
- Preset Speed: 0 m/min
- Current Speed: 0 m/min

Parameters section:

- Buttons: Load, Save, Factory Default, Exit

Label	Value*	Description	Input DW
Operation Mode	[Normal]	See the section below to determine the appropriate operation mode.	0.0
	Batch		
Measurement Unit	[Meter]	Select for length measurement in metres and speed measurement in meters per minute	0.3-4
	Feet	Select for length measurement in feet and speed measurement in feet per minute.	
	Yards	Select for length measurement in yards and speed measurement in yards or feet per minute.	
	Inch	Select for length measurement in inch and speed measurement in feet per minute.	
Length Speed Resolution	0.1 & 0.01	Select to set the length resolution to 0.1 units and speed resolution to 0.01 units/minute, where the units are metres, feet or yards depending on the "Measurement Unit" setting.	0.8
	[0.0001 & 0.001]	Select to set the length resolution to 0.0001 units and speed resolution to 0.001 units/minute, where the units are metres, feet or yards depending on the "Measurement Unit" setting.	
Speed Decimal Point	0	Set the number of digits after the decimal point to be displayed for the measured speed.	-
	0.0		
	0.00		
	0.000		
Length Decimal Point	0	Set the number of digits after the decimal point to be displayed for the measured length.	-
	0.0		
	0.00		
	0.000		
	0.0000		
Object Detection	[OFF]	See the section below for information on "Object Detection" mode.	0.11
	ON		

Auto Reset When Object Detected	[OFF]	Accumulate the length measurement across all discrete objects.	0.12
	ON	Reset the length measurement on detection of the next discrete object.	
Object Detection Threshold	0 ~ [15] ~100%	Set a DC level percentage threshold above which an object is considered as present.	-
Length Auto Save	[OFF]	The length measurement will be reset to zero when the gauge is powered-up.	0.10
	ON	The length measurement just prior to a power interruption is stored in non-volatile memory and will resume from this stored value on subsequent power-up.	
Speed Averaging Time	5 ~ [200] ~ 5000ms	Set the time period (in milliseconds) over which the measured speed is averaged.  A longer averaging period results in a more stable speed measurement (and pulse output rate) which is less sensitive to small and sudden speed changes.	2
Hold Time	1 ~ [100] ~ 5000ms	Set the time to hold the last speed measurement after speed signal loss.  The "Hold Time" should be set to a sufficiently long period to cover any momentary speed signal dropouts due to surface irregularities on the measured object.	3
Length Offset	-3000.0 ~ 3000.0 m{ft}{yds}{inch}	Set the length offset value.  For an object threaded through the production line, the unmeasured length located beyond the gauge may be entered here (as a positive value) to add to the measured length to yield the correct total length.	14
Speed Compensation	[1.0000]	Set a value other than the default value of 1.0000 to apply a compensation factor to the measured speed.	38
Minimum Speed Limit	[0] ~ 6553.5 m{ft}{yds}/min	Set the minimum speed at which the gauge is required to measure speed; for speeds below this value, the gauge will register a speed of zero.  This value may be set to avoid drift in the measured length when the object is stationary due to measurement noise.	11
Acceleration Limit	1 ~ [9999] m{ft}{yds}/min/s	Not currently in use.	39
Reel Number		Displays the current reel number.  The "Reel Number" may be incremented by activation of a logic input configured for the "End of Reel" function.	-
Panel Key Button Switch	[Enabled]	When "Enable" is selected, the two buttons (Reset and Pause) located on the LCD display of the gauge will be active.	
	Disabled	When "Disable" is selected, the two buttons (Reset and Pause) located on the LCD display of the gauge will be inactive to avoid wrong operations.	
Reset		Click to reset the "Reel Number" to zero.  The "Reel Number" may also be reset by activation for longer than 5 seconds of a logic input configured for the "Reset" function.	
Test	<b>The "Test" function simulates the measurement of a user set speed by the gauge even when there is no object being measured; pulse outputs will generate pulses corresponding to the "Preset Speed".</b>		

Speed Mode	Normal	Select for normal operation.	44
	Simulation	Select for simulated measurement.	
Random	Unticked	The gauge will behave as if it is measuring the “Preset Speed”.	-
	Ticked	The gauge will behave as if it is measuring a randomly changing speed.	
Preset Speed	0 ~[100] ~6553.5 m{ft}{yds}/min	Set the required simulation speed measurement.	45
Current Speed		This indicates the current simulated speed.	-
Parameters	<b>The “Parameters” section is for bulk saving and loading of parameters settings to and from a file.</b>		
Load		Load parameters from a file.	-
Save		Save current parameters to a file.	-
Factory Default		Restore parameters to their factory default values.	40
Exit		Click to return to the main page.	-

\* factory-default values are shown in enclosed in [ ].

{ } indicates alternative units depending on the “Measurement Unit” setting.

## Normal Operation Mode

In “Normal” operation mode, the user may set two length presets (“Preset Length 1” and “Preset Length 2”).

Whenever the measured length **exceeds** any length preset, the corresponding logic output assigned to that length preset will be activated (pulled-low).

The logic output will be deactivated (floating) when:

- The measured length is reset to zero by:
  - Activating a logic input configured for the “Reset” function.
  - Clicking the PCiS\_SLmini software “Reset” button.
  - Writing logic 1 to input parameter DW0.1.
- The measured length falls below the length preset (applicable only to the SLR mini when the measured length is decrementing due to line direction reversal).

## Batch Operation Mode

“Batch” operation mode is used when a continuous object is being measured for marking (e.g. by an inkjet printer) or cutting (e.g. by a guillotine) at regular intervals.

In “Batch” mode, the user may set a “Batch Length” and a “Batch Number”.

As each “Batch length” segment of the object is measured, the corresponding logic output assigned to the “Batch Length” function will be **momentarily** activated (pulled-low; the activation time may be configured by the user).

When the total number of segments measured **equals or exceeds** the “Batch Number”, then the corresponding logic output assigned to the “Batch Number” function, will be activated (pulled-low).

The real-time measured segment and total lengths may be viewed using the PCiS\_SLmini software or read out of the gauge from output parameters DW6-7 and DW12-13 respectively. The current segment number may be read from output parameter DW10.

DW	Bit	Comments	Units	Range/Remark
6		Length	Old format: 1=0.1m{ft}{yds}{inch}	±200,000.0000
7			New format: 1=0.0001m{ft}{yds}{inch}	
10		Batch number	1=1	
12		Total length	1=0.1m{ft}{yds}{inch}	±200,000.0000
13				

The “Batch Number” logic output will be deactivated (floating) when the measured length is reset to zero by:

- Activating a logic input configured for the “Reset” function.
- Clicking the PCiS\_SLmini software “Reset” button.
- Writing logic 1 to input parameter DW0.1.

### Object Detection Mode

The “Object Detection” mode is used when measuring the speed and length of **discrete** objects (e.g. multiple separate parts on a conveyor belt). The “Object Detection” mode forces the speed reading to zero when no object is present.

An object is determined as present if the detected DC level (in percent) exceeds the “Object Detection Threshold”; the factory default value for this threshold is 15% and it may be adjusted on the “Measurement” page of the PCiS\_SLmini software in the event of incorrect object detection behaviour.

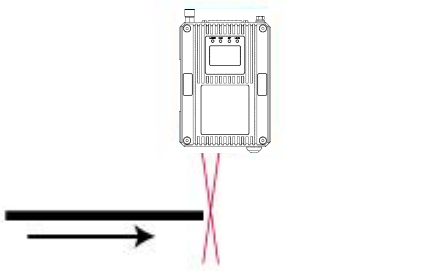
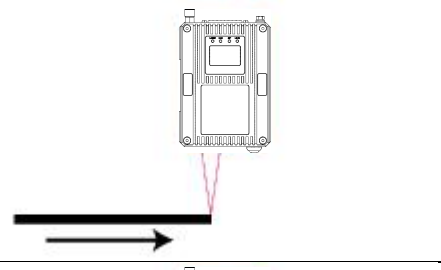
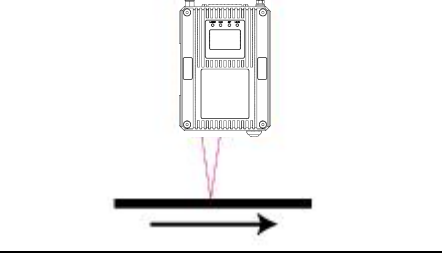
	Status	Speed measurement
No object detected		0 (zero)
Object detected Maximum leading edge reaction time: 1ms delay after the object blocks the laser beams)		Line speed
Object detected		Line speed

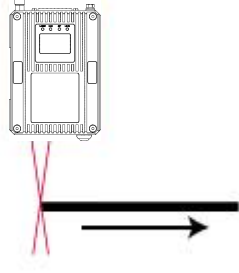
<p>No object detected</p> <p>Maximum trailing edge reaction time: 1ms delay after the object unblocks the laser beams</p>		<p>0 (zero)</p>
---	--	-----------------

The “Object Detection” mode may be configured to automatically reset the measured length when a new object is detected:

Auto Reset When Object Detected*	Length measurement behaviour
[OFF]	The gauge measures the total length accumulated across multiple discrete objects.
ON	The gauge measures the length of each individual discrete object; detection of the next object resets the length measurement to zero so that only the length of the next object is measured.

\* [ ] indicates the factory-default setting.

#### “Hold Time” behaviour in “Object Detection” mode

In “Object Detection” mode, the “Hold Time” only applies when an object is detected.

If an object is detected, but the speed signal is momentarily lost (possibly due to a surface defect on the object), then the gauge will hold the last speed measurement for the “Hold Time” period and accumulate length accordingly during this period.

The “Hold Time” should be set to a sufficiently long period to cover any momentary speed signal dropouts due to surface irregularities on the measured object.

When an object is not detected, the gauge will NOT hold the last speed measurement (or accumulate length).



# STANDARD COMMUNICATIONS INTERFACES

## CAN-BUS COMMUNICATIONS

This CAN-bus interface is fitted as standard. It operates independently of the other communications interfaces and may be accessed at the same time as them.

The CAN-bus interface uses a proprietary Proton Products protocol. It is exclusively used to communicate between the unit and other Proton Products modules. The unit automatically detects connection to other modules and configures the bus appropriately; it is not normally necessary to manually configure this interface.

**The CAN-bus interface is not intended for use with an external CAN-bus network.**

### CAN-bus interface

The CAN-bus interface may be accessed through the following pins:

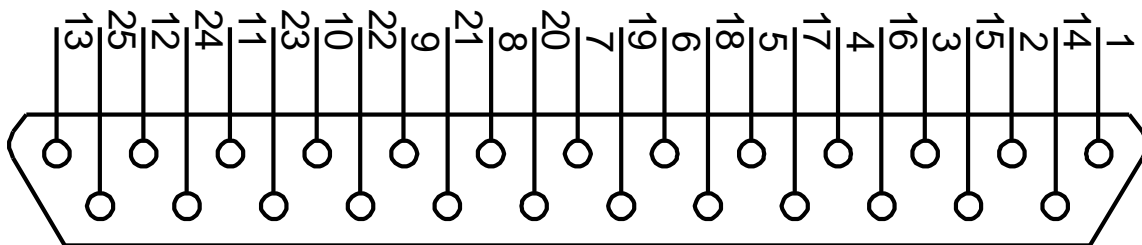

Connector type: DB25 female (socket)

Functional group	Pin	Designation	Description	Notes
Shield	S	Shield	Shield	Ensure that the cable shield is connected to the plug shield connection.
Power supply	25	+24V SUPPLY	+24V power supply	
	2	DGND	Power supply and signal ground (0V)	
	15			
CANbus	24			
	8	CAN H	CANbus high	
	9	CAN L	CANbus low	

### CAN-bus LED indicator

CAN		LED status	Indication
		CAN-bus communications	
Flashing red	Communication error		
Extinguished	No communication		

## CAN-bus configuration

Configuration via the PCiS\_SLmini software:

1 Click the “Comms” button on the main page:

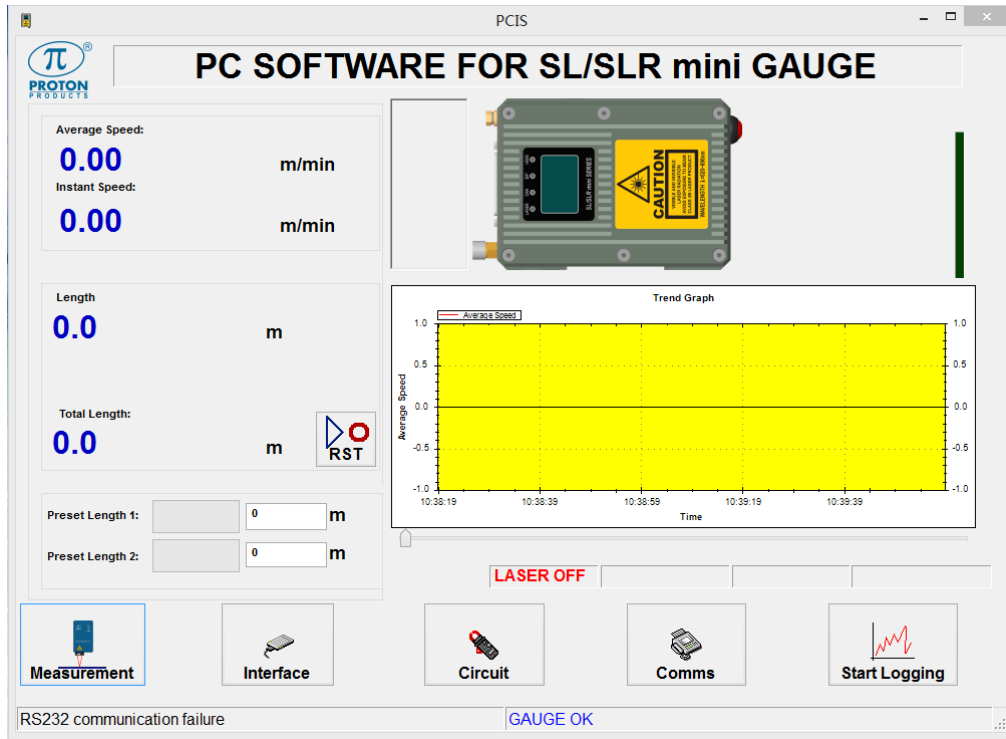

2 When prompted, enter 65000 for the password and click the “OK” button:

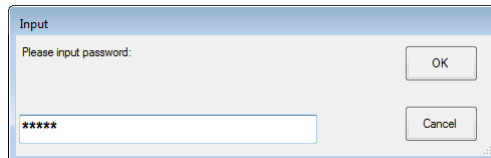

3 | Configure the CANbus interface as required and click the “Exit” button when complete:

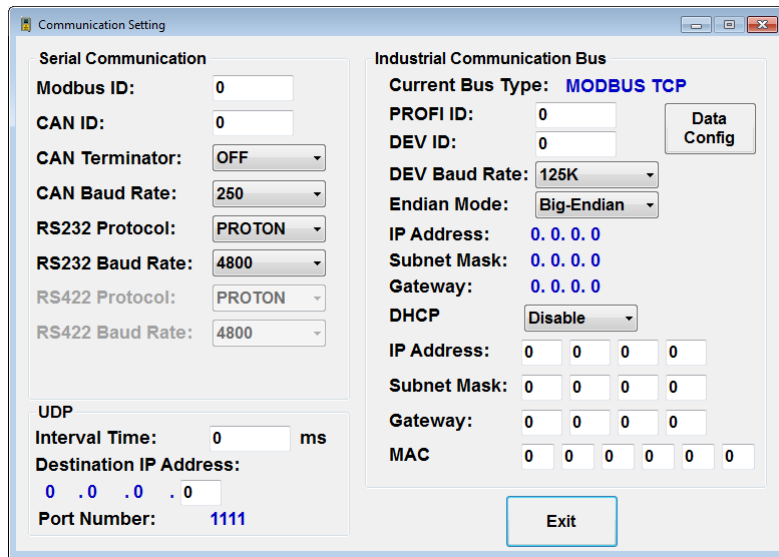

Label	Value	Description
CAN ID	0 ~ 255	Enter the CANbus address for the gauge.
CAN Terminator	OFF	If the gauge is not located at the end of the CANbus, then select “OFF” to disable the internal termination resistor.
	ON	If the gauge is located at the end of the CANbus and no external termination resistor has been installed, then select “ON” to enable the internal termination resistor.
CAN Baud Rate	250	Select the required CANbus baud rate (in kbps).
	500	
	1000	

**Configuration via input parameters:**

This interface may be configured by writing to the following input parameters:

**Input parameters**

DW	Bit	Comment	Unit	Range/Remark	Default
21		CAN address	1=1	0~255	14
22		CAN baud rate		0=250 1=500 2=1000 other=500	2
36		CAN terminator	1=1	0=Off 1=On	0

## RS-232 COMMUNICATIONS

This RS-232 interface is fitted as standard. It operates independently of the other communications interfaces and may be accessed at the same time as them.

If the RS-232 interface “Mode” is set to “ZM400 Printer”, then a Zebra ZM400 printer may be connected to the port to print reel report tickets when triggered by the “End of Reel” logic input.

### RS-232 interface

The RS-232 interface may be accessed through the following pins:

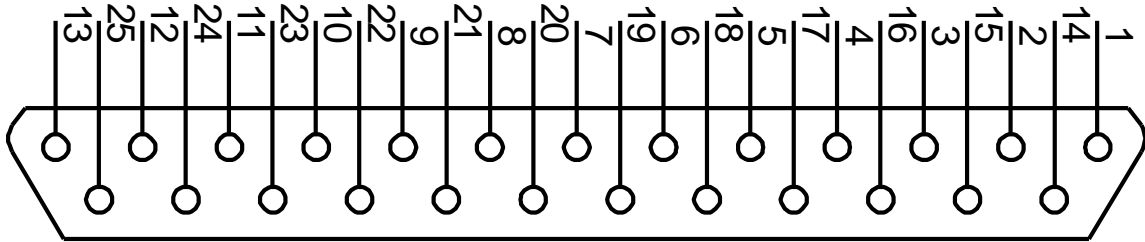

Connector type: DB25 female (socket)

Functional group	Pin	Designation	Description	Notes	PC DB9 serial port pin
Shield	S	Shield	Shield	Connect to cable and connector shields	Shield
Power supply and ground	2	DGND	Power supply and signal ground (0V)		5
	15				
	24				
RS-232	16	RXD	RS-232 receive		3
	17	TXD	RS-232 transmit		2

The above table also shows the configuration of a cable for connection to a personal computer (PC) type DB9 serial port.

The maximum baud rate depends on the cable capacitance and length. For low-cost overall shielded cable with total capacitance of shield to core-plus-core to core of 300pF per metre, the maximum recommended baud rates are as follows:

Cable length range / m		Maximum Baud rate / s
0	3	115200
3	10	38400
10	20	19200
20	40	9600
40	80	4800

## RS-232 Communications configuration

Configuration via the PCiS\_SLmini software:

- 1 Click the “Comms” button on the main page:

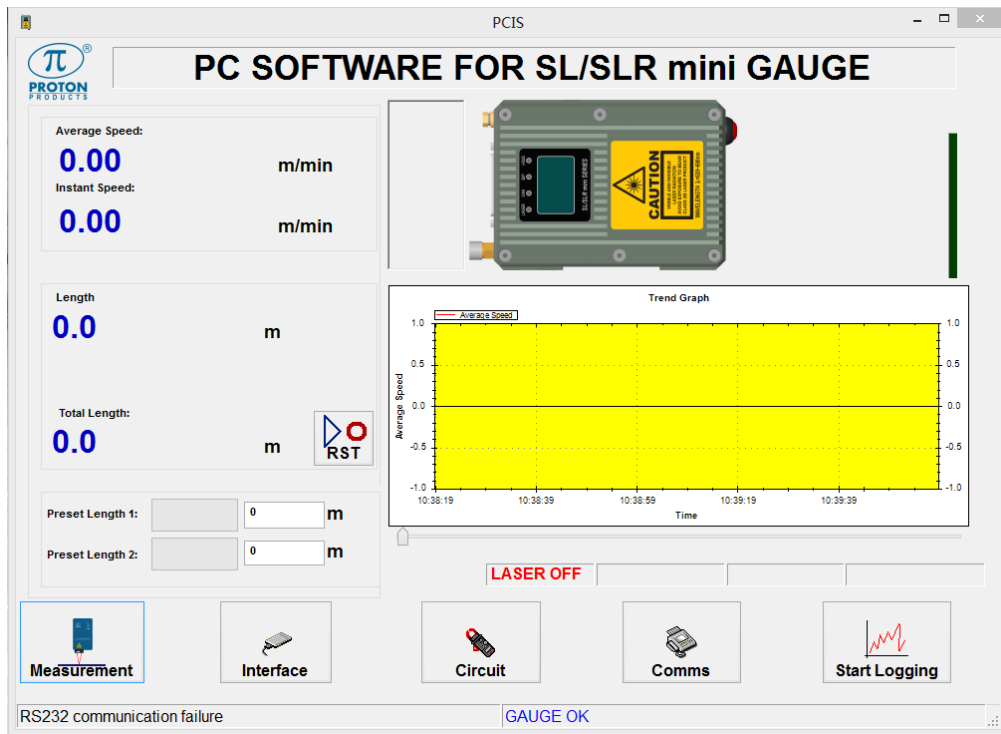

- 2 When prompted, enter 65000 for the password and click the “OK” button:

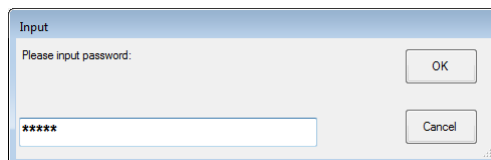

3 | Configure the RS-232 interface as required and click the “Exit” button when complete:

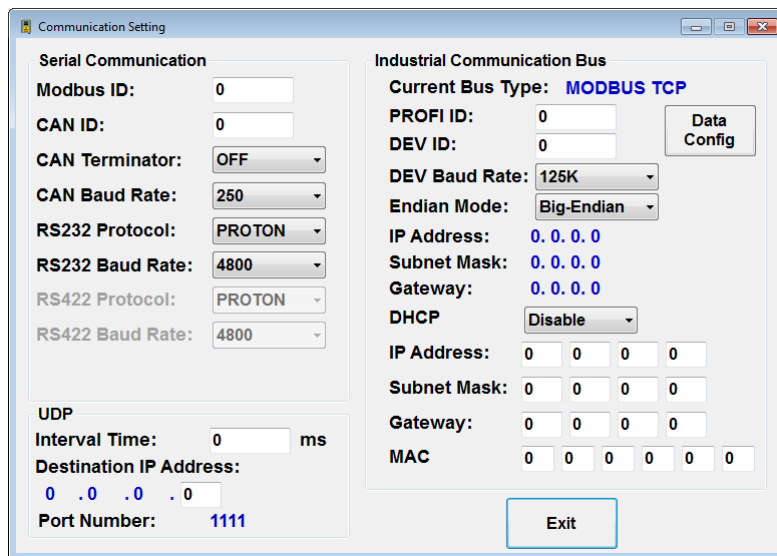

Label	Value	Description
RS232 Protocol	PROTON	Select this to use the “Proton Standard Parameter Access Protocol”.
	Modbus	Select this to use the “Modbus Parameter Access Protocol”.
	ZM400 Printer	Select this if connecting a ZM400 printer to the RS-232 port for “End of Reel” ticket printing.
CAN Baud Rate	4800	Select the required RS-232 baud rate (in kbps).
	9600	
	19200	
	38400	
	115200	

### Configuration via input parameters:

This interface may be configured by writing to the following input parameters:

DW	Bit	Comment	Unit	Range/Remark	Default
23		RS232 baud rate		0=4800 1=9600 2=19200 3=38400 4=115200	1
24		RS232 mode		0=Proton protocol 1=Modbus protocol 2=ZM400 Printer	1

### RS-232 Printing

If the RS-232 interface “Mode” is set to “ZM400 Printer” (input parameter DW24 set to “2”), then a Zebra ZM400 printer may be connected to the port to print End of Reel report tickets when triggered by the “End of Reel” logic input (see the “Logic Inputs” section for connection and configuration information).

Ensure that the RS-232 baud rate (input parameter DW23) is configured to the same value as set on the printer (9600 by default).

## Zebra ZM400 Cable

The gauge may either be directly connected to the printer via the DB25F “INTERFACE” port or via the DB9F RS-232 port on an optional PSU-BOB mini:

SL / SLR mini INTERFACE port		Zebra ZM400 RS-232 port	
Required cable connector: DB25M		Required cable connector: DB9M	
Designation	Pin	Pin	Designation
Shield	Shield	Shield	Shield
DGND	2	5	DGND
	15		
	24		
RXD	16	3	TXD
TXD	17	2	RXD

PSU-BOB mini RS-232 port		Zebra ZM400 RS-232 port	
Required cable connector: DB9M		Required cable connector: DB9M	
Designation	Pin	Pin	Designation
Shield	Shield	Shield	Shield
DGND	5	5	DGND
RXD	2	3	TXD
TXD	3	2	RXD

## Zebra ZM400 Printer Configuration

The Zebra ZM400 printer must be configured with the layout of the End of Reel report ticket using the following procedure:

- 1 | Install the “Zebra Designer” software onto a suitable PC.
- 2 | Install the Zebra printer drivers onto the PC (the drivers are supplied on a CD-ROM with the Zebra ZM400 printer and may also be downloaded from [www.zebra.com](http://www.zebra.com)).
- 3 | Connect the PC to the Zebra ZM400 printer using the USB cable supplied with the printer.
- 4 | Run the “Zebra Designer” software and open the “PROTON.lbl” sample label layout file:

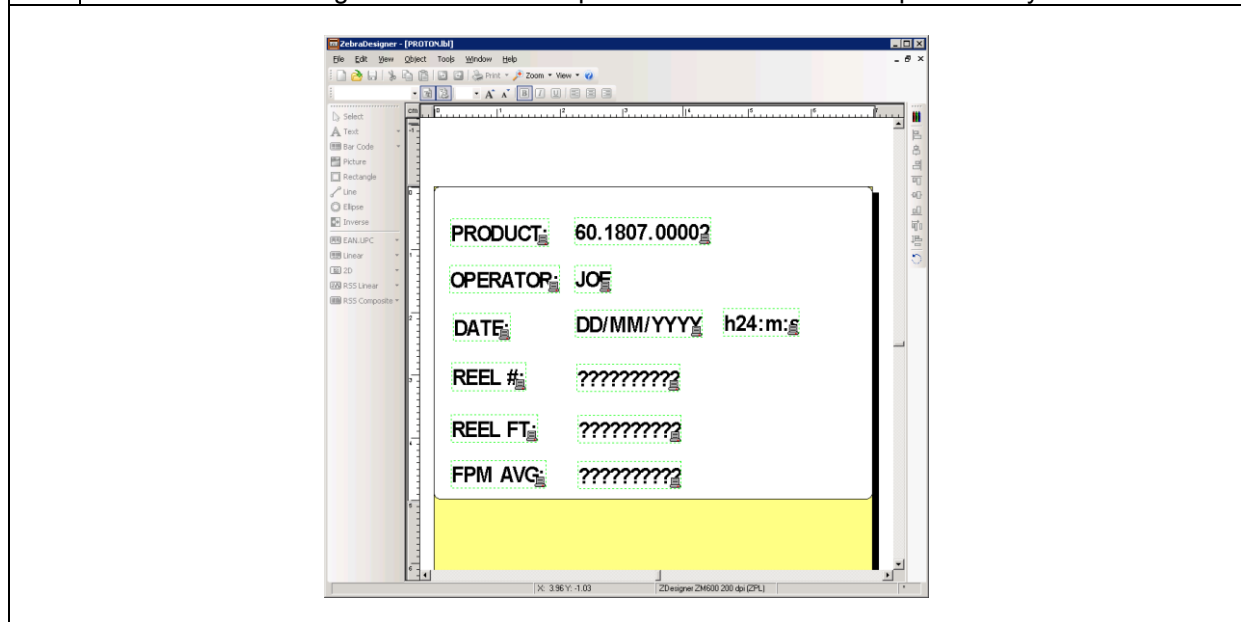

5

The gauge will send 3 strings in the following sequence to the Zebra ZM400 printer:

- String no.1: Reel number
- String no.2: Length
- String no.3: Average speed

The label layout must be designed to accommodate the above 3 strings in sequence:

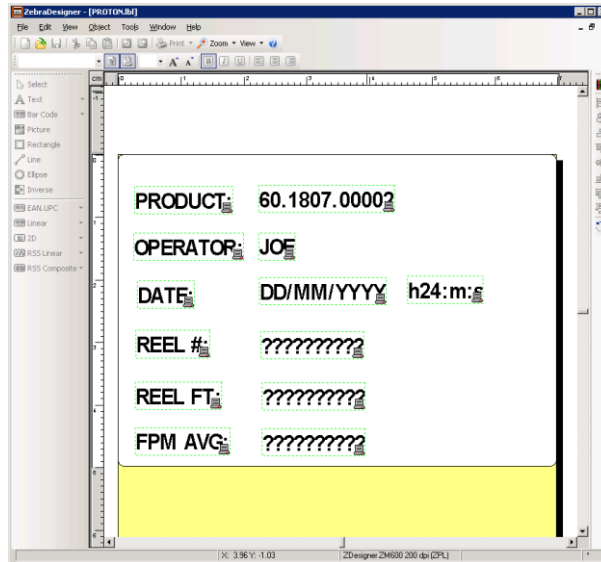

6

Export the “PROTON.lbl” file to the Zebra ZM400 printer by clicking “File → Export to Printer” in the “Zebra Designer” software and then selecting “Internal Flash” and clicking the “OK” button:

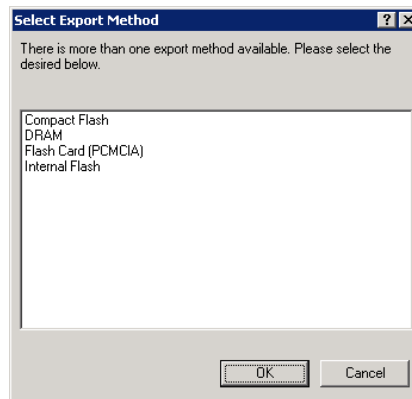

7

The Zebra ZM400 printer may be triggered to print a ticket by activating the “End of Reel” logic input on the SL / SLR mini gauge.



## Proton standard RS232 parameter access protocol

This uses a protocol to access individual parameters or blocks of parameters and is typically used in a production line environment where the gauge is connected to a PLC or similar device.

### Notes

- The parameters are split into 'Input' and 'Output' groups, the 'Input' parameters can be both read and written, and the 'Output' parameters can only be read
- The parameter number is the same as the word address used for Profibus data; refer to the 'PROFIBUS Master to Gauge and RS232 Input Parameter List' for the parameter numbers
- For 'Input' data: when a word is defined as bits then four hexadecimal characters are required to form the bits 15~0; when a word is defined as a data value then only sufficient characters to define the value in decimal format, with the decimal point where appropriate, are needed; where the data is of double word length then only the first word address is used
- For 'Output' data: when a word is defined as bits then four hexadecimal characters will be sent; when a word is defined as a data value it is converted to a decimal number with the decimal point but without leading zeros; where a double word is used then only the first word address is used to request the data, the data in both words is automatically converted to a single value
- If a PC keyboard is being used to enter the codes then the 'carriage return' plus 'line feed' are replaced by the Enter key

### SET THE VALUE OF AN 'INPUT' PARAMETER

Write Format:

&  
Input Parameter number  
Space  
Value without decimal point [0.5m = 50]  
Carriage return  
Line feed

### REQUEST VALUE ONCE FOR ONE OR A RANGE OF 'INPUT' PARAMETERS

Request Format 1: (e.g.: ?2 'ENTER')

?  
Input Parameter number  
Carriage return  
Line feed

Request Format 2: (e.g.: ?2 2 'ENTER')

?  
Input Parameter number  
Space  
Length of string  
Carriage return  
Line feed

## REQUEST CONTINUOUSLY REPEATING VALUES FOR ONE OR A RANGE OF 'OUTPUT' PARAMETERS

The repartition rate is the maximum possible and only limited by the data length and baud rate. The parameters must be consecutive when requesting multiple parameters.

Request Format 1:

```
#  
Parameter number  
Carriage return  
Line feed
```

Request Format 2:

```
#  
First parameter number  
Space  
Number of parameters  
Carriage return  
Line feed
```

Reply Format 1:

```
Parameter value  
Carriage return  
Line feed
```

Reply Format 2:

```
First output parameter value  
Carriage return  
Line feed  
Second output parameter value  
Carriage return  
Line feed  
Third output parameter and so on, until the end of the range.
```

## REQUEST VALUE ONCE FOR ONE OR A RANGE OF 'OUTPUT' PARAMETERS

The request and reply format is identical to the # format given below except that # is replaced by ~.

## Modbus parameter access protocol

This protocol provides access to individual parameters or blocks of parameters and is typically used in a production environment where the Proton Products instrument is connected to a computer, Modbus connected PLC or similar device.

The parameters consist of 16-bit words (DW) and are divided into input and output groups:

- Input parameters may be read from and written to and are used to configure the instrument.
- Output parameters are read only and provide access to instrument status and measurement data.

1 word (DW) consists of 2 bytes
1 byte consists of 8 bits
4 bits are expressed by 1 hexadecimal digit (0-9, A-F)

Proton Products instruments use the following Modbus format:

<b>Modbus format</b>	RTU (Remote Terminal Unit)
<b>Error check</b>	CRC (Cyclic Redundancy Check)

The Modbus RTU frame format is as follows:

Modbus RTU frame format			
Name	Length	Function	
Start	> 3.5 characters	>3.5 characters of silence	
Address	1-byte	Slave (instrument) Modbus address	*
Function	1-byte	Modbus function code determines read or write operation	*
Data	Multiple bytes	Length and data dependent on function	*
CRC	2-bytes	Cyclic Redundancy Check for errors (not required for Modbus TCP) <sup>+</sup>	
End	> 3.5 characters	>3.5 characters of silence	

<sup>+</sup>Please refer to Modbus Protocol Standards documentation for the CRC error check field calculation. For Modbus protocol communications over TCP/IP networks via the Ethernet port (also known as **Modbus TCP**), the CRC error check field is not required as error checking is handled by the TCP/IP protocol.

For brevity, only the fields marked \* are shown in the subsequent examples.

Proton Products instruments support the following Modbus functions:

Modbus function			Instrument operation
Code		Name	
Dec	Hex		
03	03	Read Holding Registers	Read data from a block of consecutive <b>input</b> parameters.
06	06	Preset Single Register	Write data to a single <b>input</b> parameter.
10	16	Preset Multiple Registers	Write data to a block of consecutive <b>input</b> parameters.
04	04	Read Input Registers	Read data from a block of consecutive <b>output</b> parameters.

For Modbus protocol communications via the RS-232 serial port, the RS-232 data format is:

Number of data bits	Parity	Number of stop bits	Flow control	Default baud rate
8	None	1	None	9600 bit / s

## Read data from a block of consecutive input parameters

Use Modbus function “03” (Read Holding Registers) to read from a block of consecutive input parameters.

Modbus query format		Hex
Slave Modbus address (Gauge Modbus address)		01
Modbus function code		03
Starting address (Starting input parameter address)	High byte	00
	Low byte	08
Number of points (Input parameter word count)	High byte	00
	Low byte	04

Modbus response format		Hex
Slave Modbus address (Gauge Modbus address)		01
Modbus function code		03
Byte count $N = (2 \times \text{Number of points})$		08
Data word 0 (corresponds to input DW8)	High byte	01
	Low byte	F4
Data word 1 (corresponds to input DW9)	High byte	01
	Low byte	F4
Data word 2 (corresponds to input DW10)	High byte	01
	Low byte	F4
Data word $[(N/2) - 1] = 3$ (corresponds to input DW11)	High byte	01
	Low byte	F4

The response contains the input parameter values requested in the query; its length is dependent on the number of input parameters requested.

## Write data to a single input parameter

Use Modbus function “06” (Preset Single Register) to read from a block of consecutive input parameters.

Modbus query format		Hex
Slave Modbus address (Gauge Modbus address)		01
Modbus function code		06
Register address (Input parameter address)	High byte	00
	Low byte	06
Preset data (Input parameter value)	High byte	03
	Low byte	E8

Modbus response format		Hex
Slave Modbus address (Gauge Modbus address)		01
Modbus function code		06
Register address (Input parameter address)	High byte	00
	Low byte	06
Preset data (Input parameter value)	High byte	03
	Low byte	E8

The response is an echo of the query.

## Write data to a block of consecutive input parameters

Use Modbus function “16 (10 Hex)” (Preset Multiple Registers) to write to a block of consecutive input parameters.

Modbus query format		Hex
Slave Modbus address (Gauge Modbus address)		01
Modbus function code		10
Starting address (Starting input parameter address)	High byte	00
	Low byte	01
Number of registers (Input parameter word count)	High byte	00
	Low byte	03
Byte count N = (2 × Number of registers)		06
Data word 0 (corresponds to input DW1)	High byte	1F
	Low byte	40
Data word 1 (corresponds to input DW2)	High byte	1F
	Low byte	40
Data word [(N/2) – 1] = 2 (corresponds to input DW3)	High byte	1F
	Low byte	40

Modbus response format		Hex
Slave Modbus address (Gauge Modbus address)		01
Modbus function code		10
Starting address (Starting input parameter address)	High byte	00
	Low byte	01
Number of registers (Input parameter word count)	High byte	00
	Low byte	03

The response contains the starting input parameter address and the count of input parameter words written.

## Read data from a block of consecutive output parameters

Use Modbus function “04” (Read Input Registers) to write to a block of consecutive input parameters.

Modbus query format		Hex
Slave Modbus address (Gauge Modbus address)		01
Modbus function code		04
Starting address (Starting output parameter address)	High byte	00
	Low byte	02
Number of points (Output parameter word count)	High byte	00
	Low byte	03

Modbus response format		Hex
Slave Modbus address (Gauge Modbus address)		01
Modbus function code		04
Byte count N = (2 × Number of points)		06
Data word 0 (corresponds to output DW2)	High byte	07
	Low byte	D0
Data word 1 (corresponds to output DW3)	High byte	05
	Low byte	DC
Data word 2 [(N/2) – 1] (corresponds to output DW4)	High byte	09
	Low byte	C4

The response contains the output parameter values requested in the query; its length is dependent on the number of output parameters requested.

## ETHERNET COMMUNICATIONS

This Ethernet interface is fitted as standard. It operates independently of the other communications interfaces and may be accessed at the same time as them.

If an optional industrial bus interface (Ethernet/IP, PROFIBUS or DeviceNET) has been installed in the gauge, then the Ethernet interface is substituted by the industrial bus interface.

### Ethernet interface

The Ethernet interface may be accessed through the following pins:

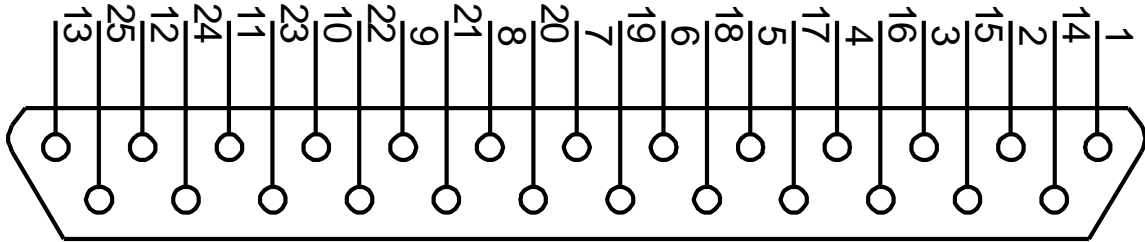

Connector type: DB25 female (socket)

Functional group	Pin	Designation	Description	Notes
Shield	S	Shield	Shield	Connect to cable and plug shields
Ethernet	22	IBUS1	TX+	
	10	IBUS2	TX-	
	23	IBUS3	RX+	
	11	IBUS4	RX-	

### Ethernet LED indicator

EIP	LED status	Indication
Ethernet communications	 Continuous green	Online and connected
	Flashing green	Online but not connected
	Continuous red	Critical link failure
	Flashing red	Connection timeout

## Ethernet configuration

Configuration via the PCiS\_SLmini software:

1 | Click the “Comms” button on the main page:

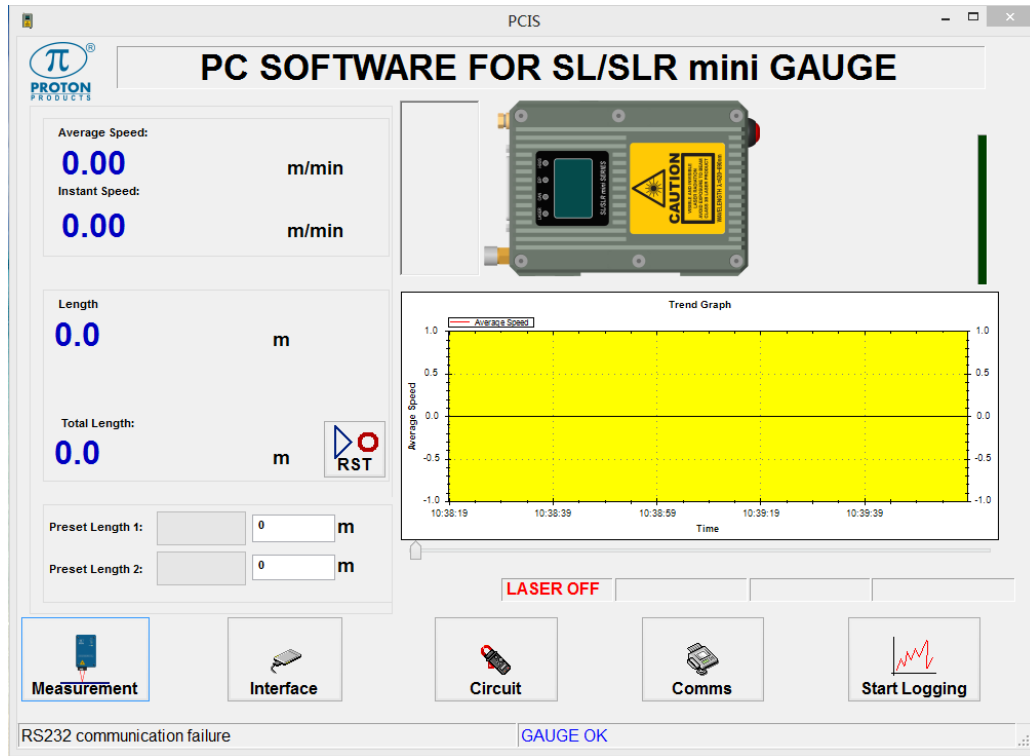

2 | When prompted, enter 65000 for the password and click the “OK” button:

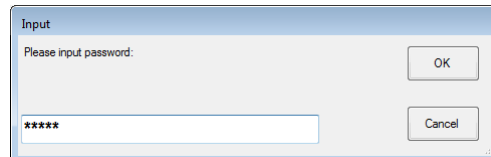



3 | Configure the Ethernet interface as required and click the “Exit” button when complete:

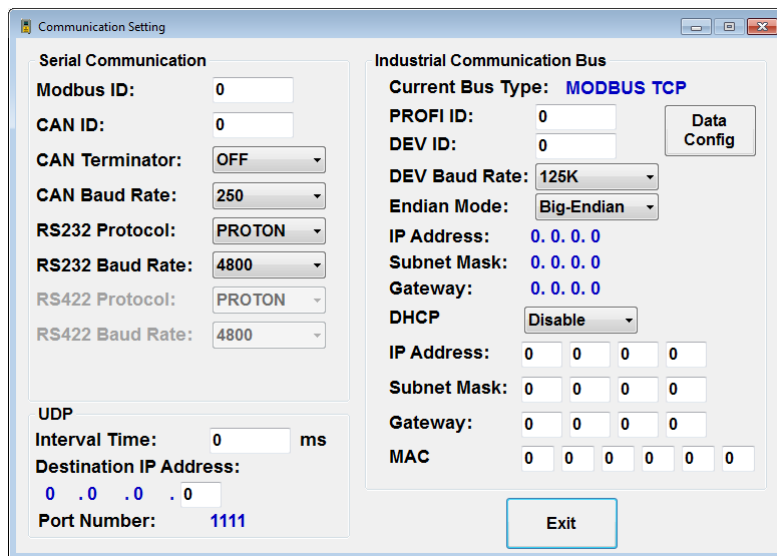

Label	Value	Description
DHCP	Enable	Select this option to enable the gauge to automatically acquire its IP Address, Subnet Mask and Gateway from a DHCP server on the network.
	Disable	Select this option to manually configure the gauge IP Address, Subnet Mask and Gateway in the fields below:
IP Address	[192.168.1.110]	Enter the IP address assigned to the gauge in dotted decimal format.
Subnet Mask	[255.255.255.0]	Enter the subnet mask for the network in dotted decimal format.
Gateway	[192.168.1.1]	Enter the gateway for the network in dotted decimal format.

\* [ ] indicates factory-default values.

### Configuration via input parameters:

This interface may be configured by writing to the following input parameters:

#### Input parameters

DW	Bit	Comment	Unit	Range/Remark	Default
27		Modbus address	1=1	0~255	1
28		EtherNet protocol		0=Modbus protocol 1=EIP protocol	0
29		DHCP		0=Disabled 1=Enabled	0
30		IP address	x.x.x.x		C0A8016E (192.168.1.110)
31					
32		Subnet mask	x.x.x.x		FFFF0000 (255.255.255.0)
33					
34		Gateway	x.x.x.x		C0A80001 (192.168.1.1)
35					

## Input Parameter Write Disable

The gauge may be configured to write-disable specific input parameters when a page of input parameters is written via the optional DeviceNET, PROFIBUS, PROFINET or EtherNet/IP communications interface.

Input parameters may be write-disabled for the following purposes:

- **To simplify setup:** all unused input parameters may be write-disabled to simplify the composition of the written data page.
- **To avoid unintended modification of specific parameters:** input parameters which must NOT be changed via the optional communication interface (e.g. input parameters which determine the operating mode of the gauge) may be write-disabled.

Input parameter write-disable does NOT apply to the CANbus, RS-232 or Ethernet interfaces.

1 | Click the “Comms” button on the main page:

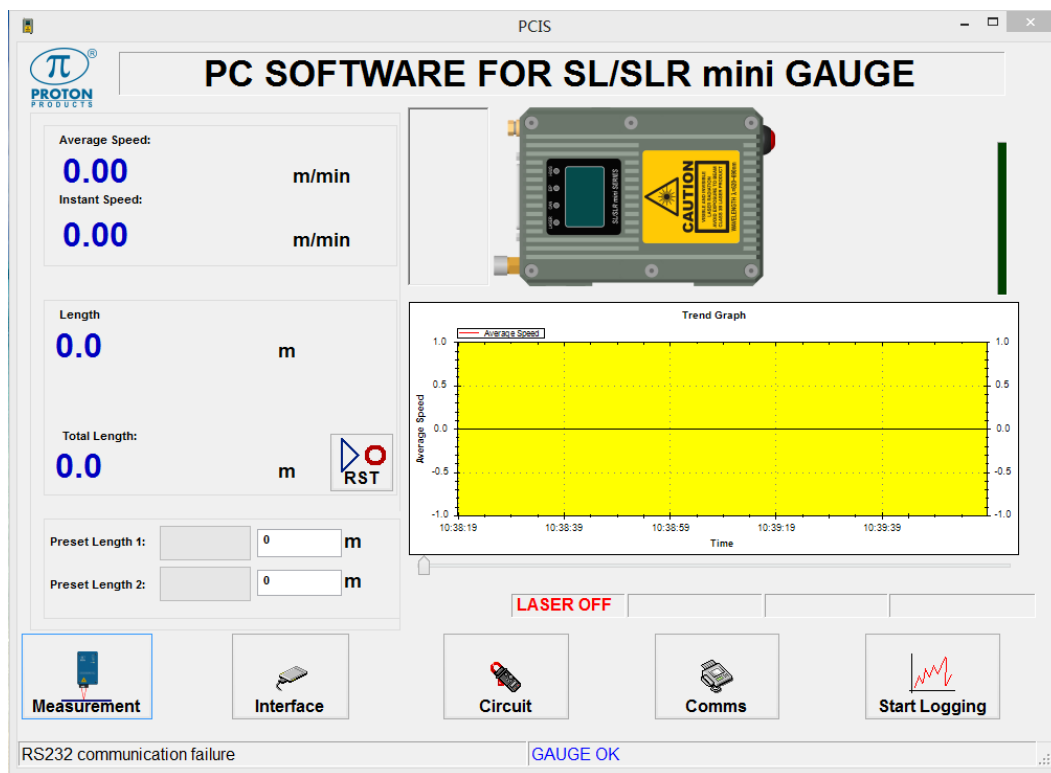

2 | When prompted, enter 65000 for the password and click the “OK” button:

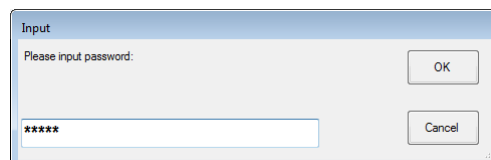

3 Click the “Data Config” button to access the “Data Configuration for Master to Slave” page:

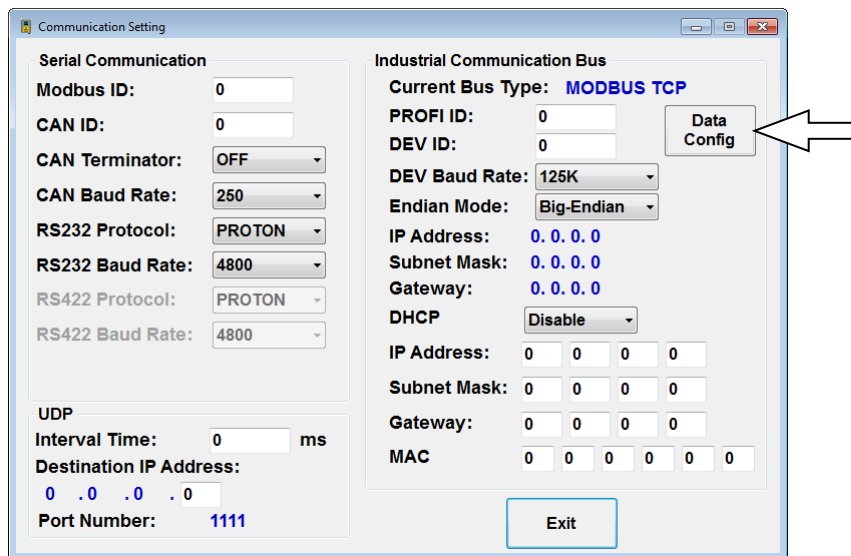

4 When prompted, enter 65065 for the password and click the “OK” button:

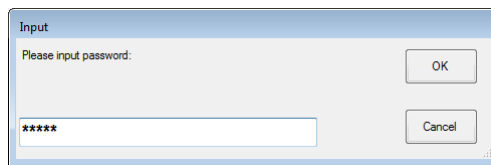

5 Enable or disable writing of input parameter DW words or bits via the optional DeviceNET, PROFIBUS, PROFINET or EtherNet/IP communications interfaces:

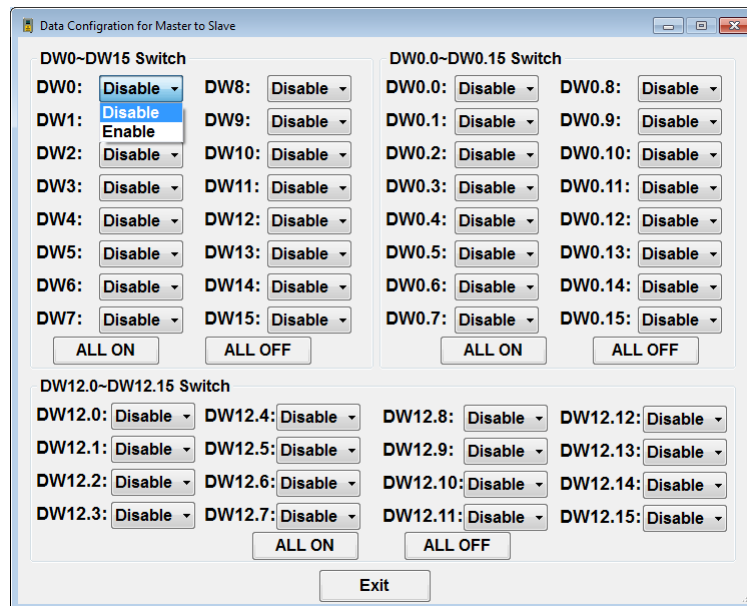

Label	Description
Enable	Select to <b>enable</b> writing of the specific input parameter DW word or bit.
Disable	Select to <b>disable</b> writing of the specific input parameter DW word or bit.
ALL ON	Click to <b>enable</b> writing of <b>all</b> associated input parameter DW words.
ALL OFF	Click to <b>disable</b> writing of <b>all</b> associated input parameter DW words.
Exit	Click to exit this page and return to the “Communication Setting” page.

## UDP Protocol

The gauge may be configured to continuously send data by UDP-protocol (at a user-configured rate) to a server on the same network.

### Configuration via the PCiS\_SLmini software:

- 1 Click the “Comms” button on the main page:

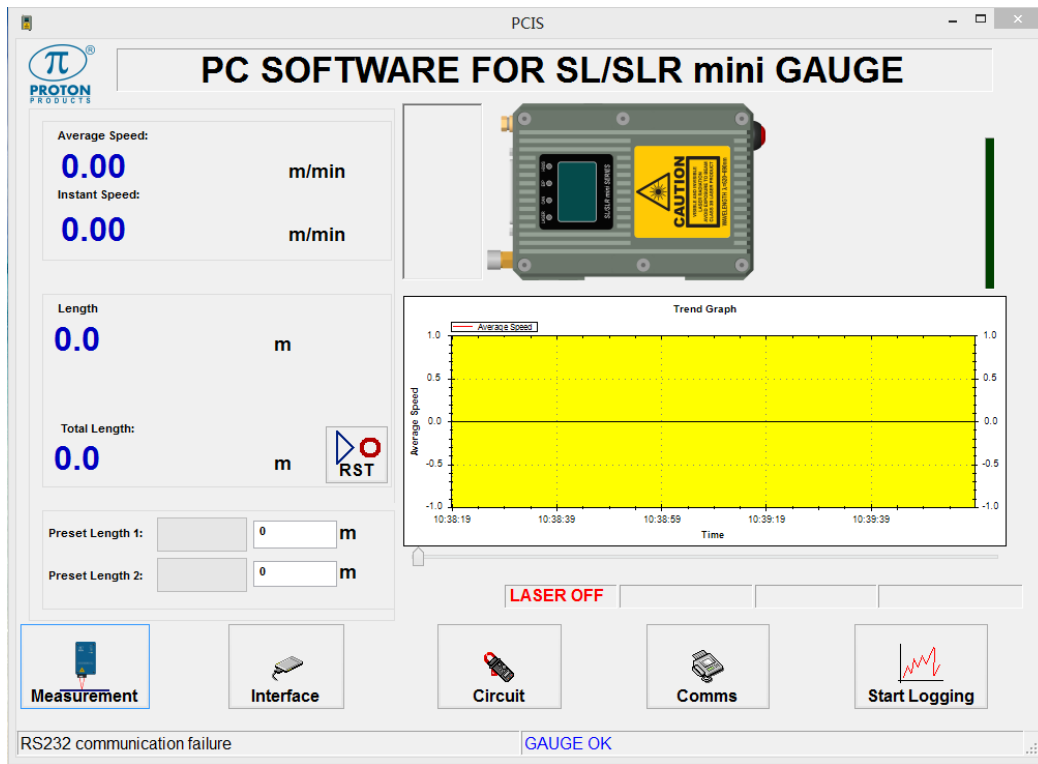

- 2 When prompted, enter 65000 for the password and click the “OK” button:

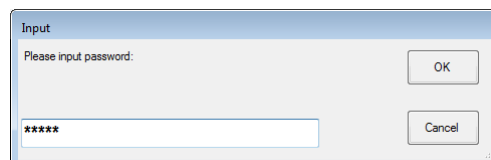

3 | Configure the Ethernet interface as required and click the “Exit” button when complete:

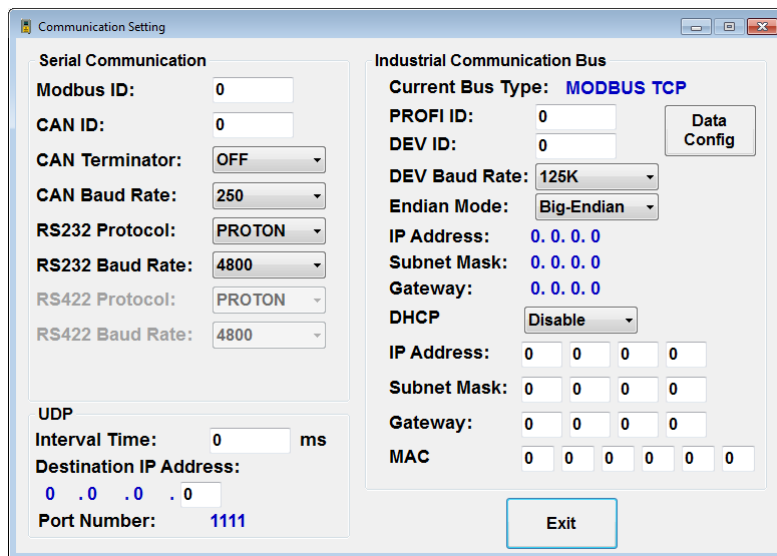

Label	Value	Description
Interval Time	0	Disable UDP data output.
	1 ~ 5000 ms	Output UDP data at this interval time.
Destination IP Address	x.x.x.x	Destination server IP address to which UDP data is sent (only the final octet is configurable, the first 3 octets are the same as the gauge IP Address, hence the destination server must be on the same network as the gauge).
Port Number	1111	Destination server port to which UDP data is sent (fixed at 1111, not end-user configurable).

### Configuration via input parameters:

The UDP data output function may be configured by writing to the following input parameters:

#### Input parameters

DW	Bit	Comment	Unit	Range/Remark	Default
30		IP address	x.x.x.x		COA80001 (192.168.0.1)
31					
41		UDP data output interval time	1=1ms	1-5000 0=Disable UDP output	0
48		UDP destination IP address (last octet only)		<b>Note:</b> the UDP destination port number is fixed at 1111	2

## OPTIONAL COMMUNICATIONS INTERFACES

### PROFIBUS COMMUNICATIONS

The PROFIBUS interface is an optional extra that must be ordered for installation during manufacture; it cannot be retrofitted to the gauge.

This communications interface operates independently of the other communications interfaces and may be used at the same time as them.

#### PROFIBUS interface

The PROFIBUS interface may be accessed through the following pins:

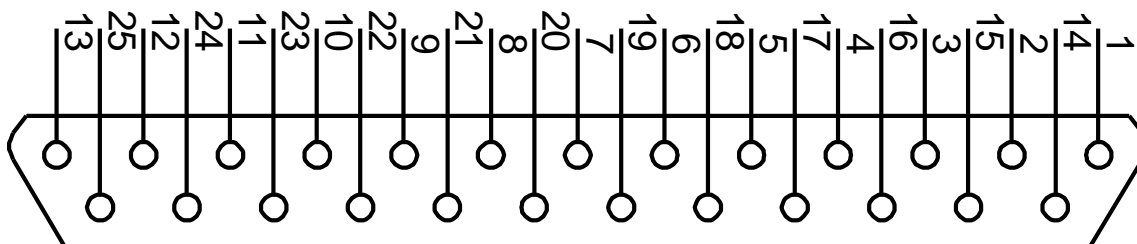

Connector type: DB25 female (socket)

Functional group	Pin	Designation	Description	Notes
Shield	S	Shield	Shield	Connect to cable and plug shields
PROFIBUS Industrial bus	22	IBUS1	+5V	
	10	IBUS2	GND	
	23	IBUS3	A	
	11	IBUS4	B	

#### PROFIBUS LED indicator

i-BUS		LED status	Indication
		PROFIBUS communications	Continuous green
		Continuous red	Communication error
		Extinguished	No communication

## PROFIBUS configuration

The gauge head is configured as a PROFIBUS slave.

### Configuration via the PCiS\_SLmini software:

- 1 Click the “Comms” button on the main page:

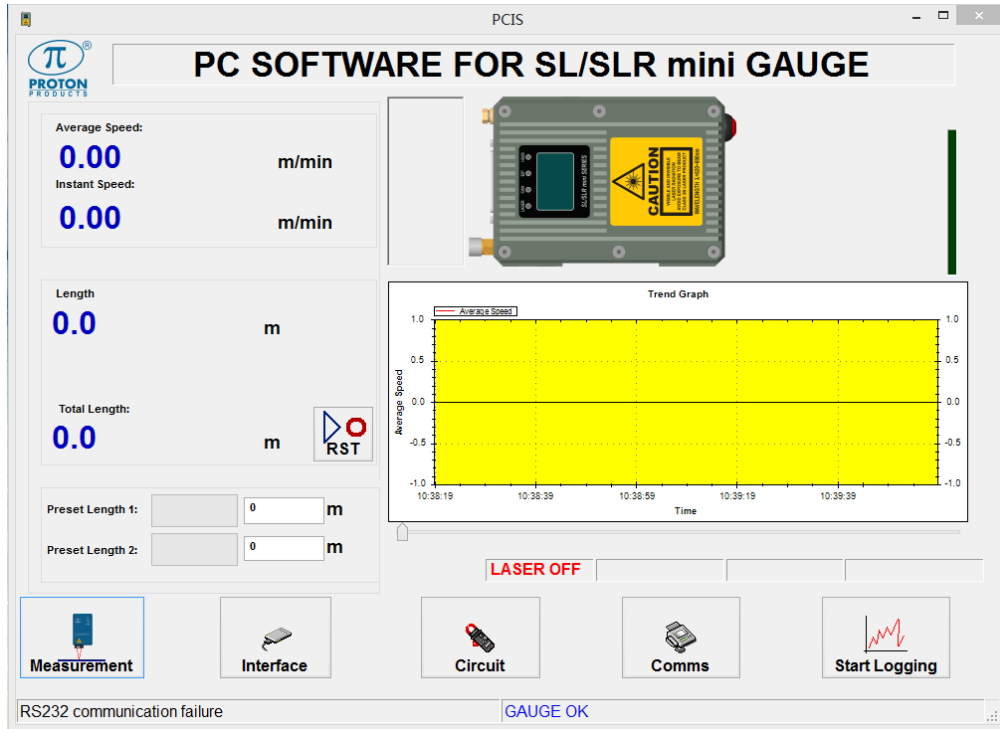

- 2 When prompted, enter 65000 for the password and click the “OK” button:

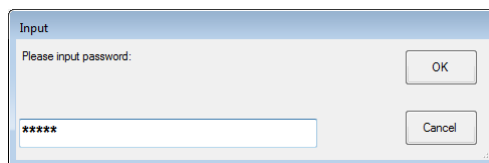

- 3 Configure the PROFIBUS interface as required and click the “Exit” button when complete:

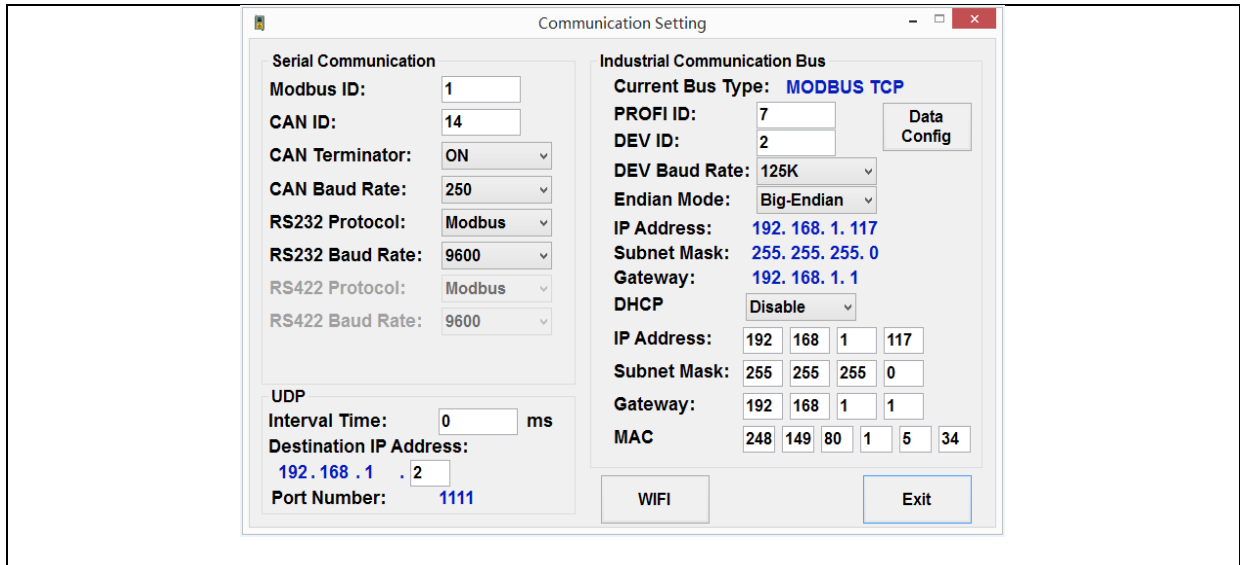

Label	Value	Description
PROFIBUS ID	0 ~ 125	Enter the PROFIBUS ID (address) assigned to the gauge.

**Configuration via input parameters:**

This interface may be configured by writing to the following input parameters:

Input parameters:

DW	Bit	Comment	Unit	Range/Remark	Default
20		Profibus address	1=1	0~125	7

**ETHERNET / IP OR PROFINET COMMUNICATIONS**

**The EtherNet / IP or PROFINET interface is an optional extra that must be ordered for installation during manufacture; it cannot be retrofitted to the gauge.**

The Ethernet/IP interface is compatible with PLCs fitted with an Ethernet/IP interface that supports the CIP (Common Industrial Protocol).

This communications interface operates independently of the other communications interfaces and may be used at the same time as them.

**EtherNet / IP or PROFINET interface**

The EtherNet / IP or PROFINET interface may be accessed through the following pins:

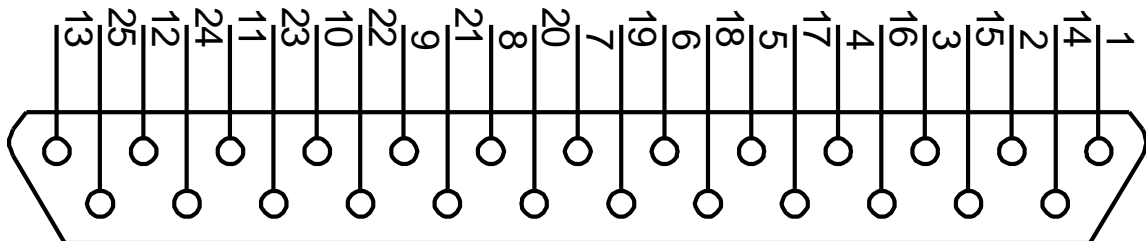

Connector type: DB25 female (socket)

Functional group	Pin	Designation	Description	Notes
Shield	S	Shield	Shield	Connect to cable and plug shields
Ethernet/IP or PROFINET Industrial bus	22	IBUS1	TX+	
	10	IBUS2	TX-	
	23	IBUS3	RX+	
	11	IBUS4	RX-	



## EtherNet / IP or PROFINET LED indicator

<b>i-BUS</b>		<b>LED status</b>	<b>Indication</b>
		Continuous green	Online
EtherNet / IP or PROFINET communications		Continuous red	Communication error
		Extinguished	No communication

## EtherNet / IP or PROFINET configuration

Configuration via the PCiS\_SLmini software:

- 1 Click the “Comms” button on the main page:

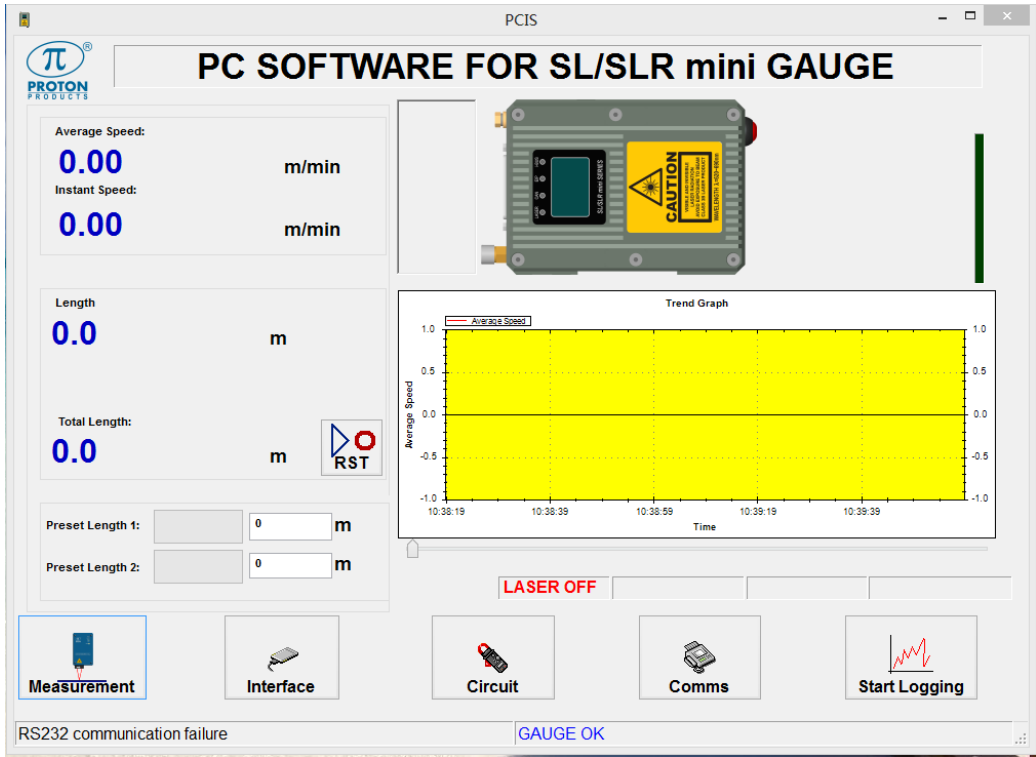

The screenshot shows the 'PC SOFTWARE FOR SL/SLR mini GAUGE' interface. It features a central display area with a gauge image and a trend graph. On the left, there are readouts for Average Speed (0.00 m/min), Instant Speed (0.00 m/min), Length (0.0 m), and Total Length (0.0 m). Below these are preset length fields. At the bottom, there are buttons for Measurement, Interface, Circuit, Comms, and Start Logging. A status bar at the bottom shows 'RS232 communication failure' and 'GAUGE OK'.

- 2 When prompted, enter 65000 for the password and click the “OK” button:

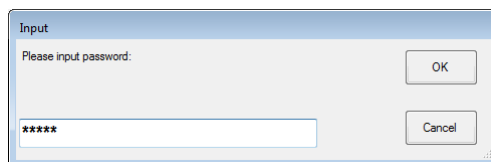

The screenshot shows an 'Input' dialog box with the text 'Please input password:'. Below the text is a password input field containing six asterisks (\*\*\*\*\*). There are 'OK' and 'Cancel' buttons to the right of the input field.

3 Configure the EtherNet / IP or PROFINET interface as required and click the “Exit” button when complete:

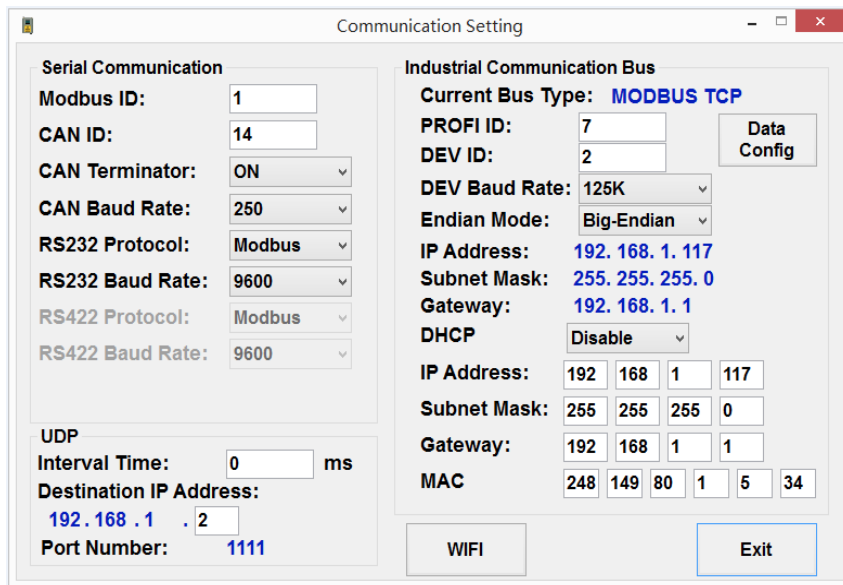

Label	Value*	Description
Endian Mode	[Big-Endian]	Select for Big-Endian data format.
	Little-Endian	Select for Little-Endian data format.
DHCP	Enable	Select this option to enable the gauge to automatically acquire its IP Address, Subnet Mask and Gateway from a DHCP server on the network.
	Disable	Select this option to manually configure the gauge IP Address, Subnet Mask and Gateway in the fields below:
IP Address	192.168.1.110	Enter the IP address assigned to the gauge in dotted decimal format.
Subnet Mask	255.255.0.0	Enter the subnet mask for the network in dotted decimal format.
Gateway	192.168.1.1	Enter the gateway for the network in dotted decimal format.

\* [ ] indicates factory-default value.

### Configuration via input parameters:

This interface may be configured by writing to the following input parameters:

#### Input parameters

DW	Bit	Comment	Unit	Range/Remark	Default
29		DHCP		0=Disabled 1=Enabled	0
30		IP address	x.x.x.x		C0A8016E (192.168.1.110)
31					
32		Subnet mask	x.x.x.x		FFFF0000 (255.255.0.0)
33					
34		Gateway	x.x.x.x		C0A80001 (192.168.1.1)
35					
49		Endianess		1=Little endian 0=Big endian	0

## DEVICENET COMMUNICATIONS

The DeviceNet interface is an optional extra that must be ordered for installation during manufacture; it cannot be retrofitted to the gauge.

This communications interface operates independently of the other communications interfaces and may be used at the same time as them.

### DeviceNet interface

The DeviceNet interface may be accessed through the following pins:

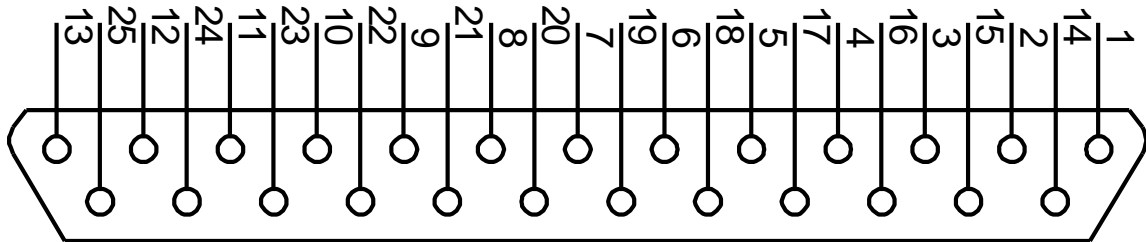

Connector type: DB25 female (socket)

Functional group	Pin	Designation	Description	Notes	DeviceNet wire colour
Shield	S	Shield	Shield	Connect to cable and plug shields	Bare wire
DeviceNET Industrial bus	22	IBUS1	V+		Red
	10	IBUS2	V-		Black
	23	IBUS3	CANH		White
	11	IBUS4	CANL		Blue

### DeviceNet LED indicator

i-BUS		LED status	Indication
		DeviceNet communications	Continuous green
		Continuous red	Communication error
		Extinguished	No communication

## DeviceNet configuration

Configuration via the PCiS\_SLmini software:

1 | Click the “Comms” button on the main page:

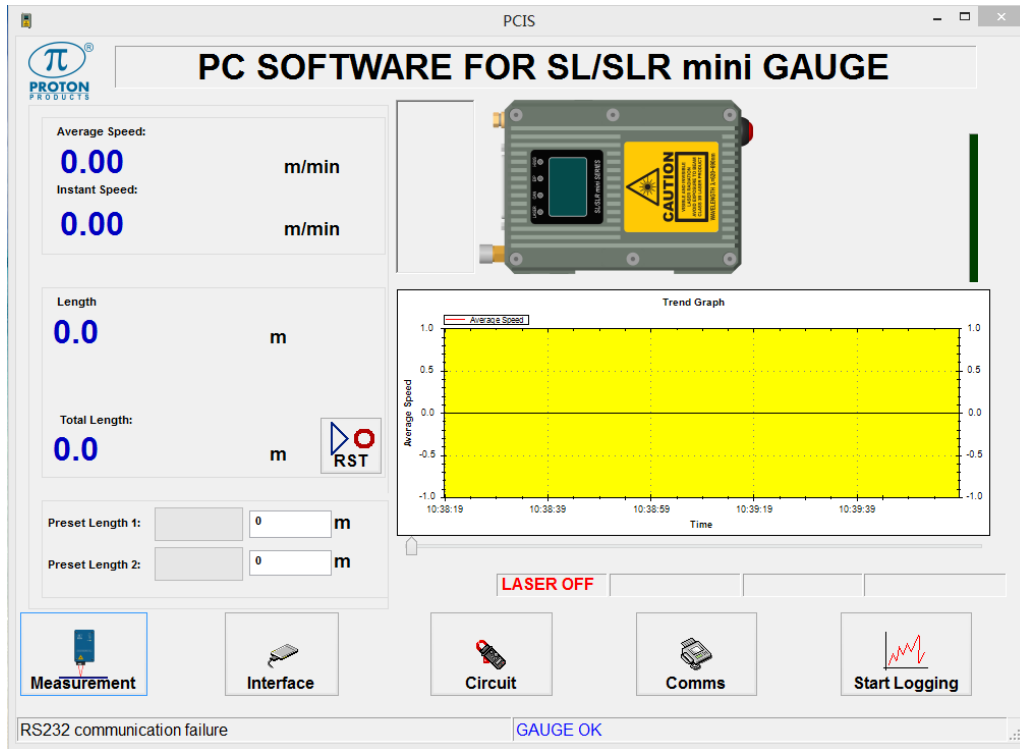

2 | When prompted, enter 65000 for the password and click the “OK” button:

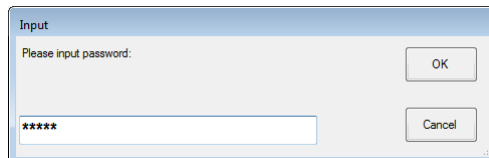

3 | Configure the DeviceNet interface as required and click the “Exit” button when complete:

Label	Value	Description
DEV ID	0 ~ 125	Enter the DeviceNet ID (address) assigned to the gauge.
DEV Baud Rate	125K	Enter the DeviceNet baud rate.
	250K	
	500K	

**Configuration via input parameters:**

This interface may be configured by writing to the following input parameters:

Input parameters:

DW	Bit	Comment	Unit	Range/Remark	Default
46		DeviceNet address		0-63	7
47		DeviceNet baud rate		0=125K 1=250K 2=500K	

# STANDARD ELECTRICAL INTERFACES

## LOGIC INPUTS

### Logic inputs connection

Two logic inputs are fitted as standard and may be accessed through the following pins:

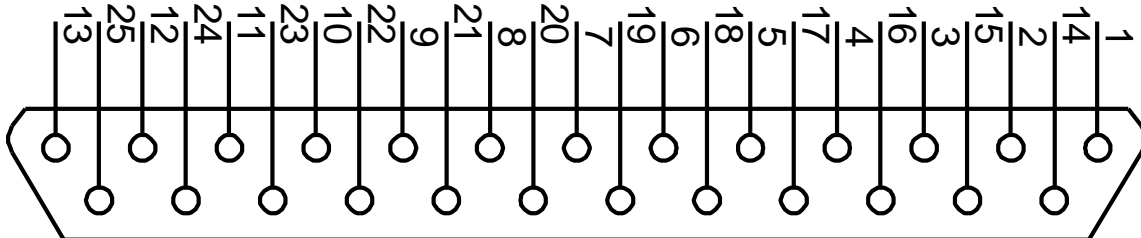

Connector type: DB25 female (socket)

Functional group	Pin	Designation	Description	Notes
Shield	S	Shield	Shield	Connect to cable and plug shields
Power supply and ground	2	DGND	Power supply and signal ground (0V)	
	15			
	24			
Logic inputs	3	LIN1	Logic input 1	Low state (logic 0) voltage < +3V High state (logic 1) voltage > +10.5V Maximum input voltage ±30V
	4	LIN2	Logic input 2	
	5	LIN3	Logic input 3	

### Logic inputs electrical specification

- Logic inputs are NOT isolated from earth.
- Inputs are internally pulled up to +15V via 8.2kΩ resistors; unconnected inputs default to the high state.
- Inputs will source a minimum current of 3mA when externally pulled down to the low state.

Specification	Minimum	Typical	Maximum	Units
Low state (logic 0) input voltage			3	V
High state (logic 1) input voltage	10.5			V
Absolute input voltage	-30		30	V
Low state source current	3			mA

Logic inputs can be connected to different types of signal sources as follows:

Signal source	Connection method
Mechanical or solid state relay contact	Connect between logic input and DGND.
Pull-down	Connect the pull-down signal to the logic input and ground to DGND.
Pull-up	<ul style="list-style-type: none"> <li>• Connect an 820Ω resistor between the logic input and DGND to pull the input down to 2.5V.</li> <li>• Connect the pull-up signal source to the logic input and ground to DGND.</li> <li>• For 24V signals (such as from a PLC), the power dissipation in the 820Ω resistor can be reduced by connecting another 820Ω in series between the pull-up signal source and logic input.</li> </ul>

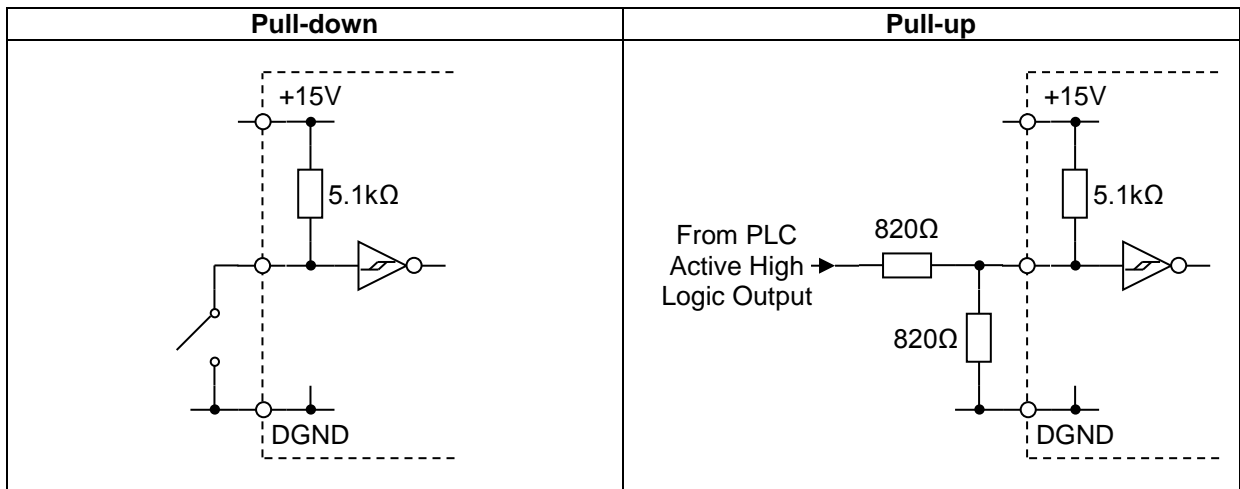

### Logic inputs configuration

Each individual logic input can be independently configured for both active state polarity and function.

#### Configuration via the PCiS\_SLmini software:

1 | Click the “Interface” button on the main page:

2 | When prompted, enter 64000 for the password and click the “OK” button:

Input

Please input password:

\*\*\*\*\*

3 | Configure the logic input interface as required and click the “Exit” button when complete:

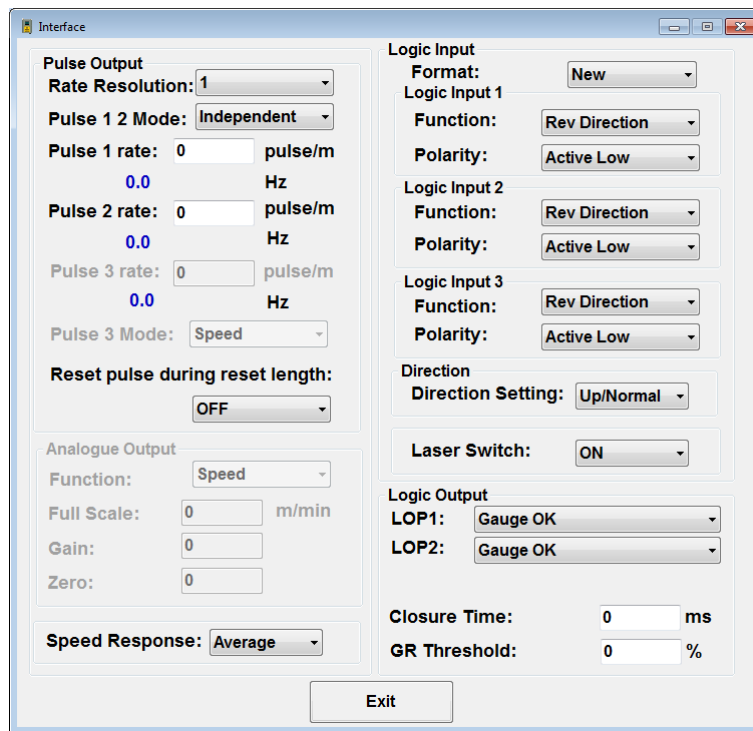

Label	Value*	Description	Input DW
Format	New	Select “New” (factory-default setting) to configure the logic inputs as below.	12.15
	Old	Select “Old” for backward compatibility with Proton Products	
<b>Logic Input 1</b>			
Function	Rev Direction	<p>Activate to reverse the length counting direction. For SL gauges, when this input is activated (for example by a direction wheel) the gauge will decrement length.</p> <ul style="list-style-type: none"> <li>See the “Measurement Direction” section for information on how this logic input affects length accumulation.</li> </ul>	12
	Length Hold	<p>Activate to hold the length measurement by forcing the speed measurement to zero.</p> <ul style="list-style-type: none"> <li>The lengths read from output parameters DW6-7 and DW12-13 will be held at their values at the instant of activation.</li> <li>The speeds read from output parameters DW2-3 and DW4-5 will be forced to zero.</li> <li>The frequency of the pulse outputs is also forced to zero.</li> </ul>	
	Display Hold	<p>Activate to hold the <b>displayed</b> speed and length measurements at the instant of activation for ease of reading.</p> <ul style="list-style-type: none"> <li>The gauge internally continues to measure speed and length and the display will revert to these live values when this logic input returns to inactive.</li> <li>The lengths read from output parameters DW6-7 and DW12-13 and speeds read from output parameters DW2-3 and DW4-5 will continue to update even with “Display Hold” active.</li> <li>The pulse outputs are NOT affected by this function and will continue to correspond to the object speed.</li> </ul>	



	Speed Hold	<p>Activate to hold the speed measurement at its value at the instant of activation.</p> <ul style="list-style-type: none"> <li>The length reading will accumulate at the held speed (including lengths read from output parameters DW6-7 and DW12-13).</li> <li>The speeds read from output parameters DW2-3 and DW4-5 will be held at their values at the instant of activation.</li> <li>The frequency of the pulse outputs is held at the corresponding speed value.</li> </ul>	
	Reset	<ul style="list-style-type: none"> <li>Activate momentarily to reset the length to zero.</li> <li>Activate for longer than 5 seconds to also reset the "Reel Number" to zero.</li> </ul>	
	End of Reel	Activate to increment the "Reel Number" and trigger printing of the End of Reel report on a Zebra ZM400 printer attached to the RS-232 port.	
Polarity	Active Low	Pulling the logic input low (logic 0) activates the configured function.	12
	Active High	Pulling the logic input high (logic 1) activates the configured function.	
<b>Logic Input 2</b>			
Function		As per "Logic Input 1" above.	12
Polarity		As per "Logic Input 1" above.	12
<b>Logic Input 3</b>			
Function		As per "Logic Input 1" above.	12
Polarity		As per "Logic Input 1" above.	12
Direction Setting	[Up/Normal]	Select this for normal length accumulation.	12.12
		<b>SL mini</b> Object motion increments length.	
		<b>SLR mini</b> Standard direction increments length.	
	Down/Invert	Select this for reverse length accumulation.	
		<b>SL mini</b> Object motion decrements the length.	
		<b>SLR mini</b> Standard direction decrements length.	
<b>Note:</b> if any of the logic inputs are configured for the "Rev Direction" function, then this "Directing Setting" is overridden by the logic input and has no effect.			
Laser Switch	[ON]	Select to switch on the laser diode.	13
	OFF	Select to switch off the laser diode.	

\* factory-default values are shown in enclosed in [ ].

### Configuration by input parameters:

This interface may be configured by writing to the following input parameters:

Input parameters

DW	Bit	Comment	Unit	Range/Remark	Default
12		<b>Logic input (old format: compatible with old SL gauge;DW12.15=0)</b>			
	0	Logic input 1 function		0=Direction 1=Length hold 2=Display hold 3=Speed hold	1
	1				
	2				
	3	Direction setting (available only when no logic input for direction)		0=Count up 1=Count down	0
	4-7	Not used			0
	8	Logic input 2 function		0=Reset input 1=Length hold	0
	9				
	10	Logic input 2 polarity		0=Active low 1=Active high	0
	11	Logic input 3 function		0=Direction 1=Length hold	1
12					

DW	Bit	Comment	Unit	Range/Remark	Default
	13			2=Display hold 3=Speed hold 4=Reset	
	14	Logic input 3 polarity		0=Active low 1=Active high	0
	15	Must be 0		0=Old format logic inputs	0
		<b>Logic input(new format;DW12.15=1)</b>			
12	0	Logic input 1 function		0=direction (count down) 1=Length hold 2=Display hold 3=Speed hold 4=Reset 5=End of Reel	0
	1				
	2				
	3	Logic input 1 polarity		0=Active low 1=Active high	0
	4	Logic input 2 function		0=direction (count down) 1=Length hold 2=Display hold 3=Speed hold 4=Reset 5=End of Reel	1
	5				
	6				
	7	Logic input 2 polarity		0=Active low 1=Active high	0
	8	Logic input 3 function		0=direction (count down) 1=Length hold 2=Display hold 3=Speed hold 4=Reset 5=End of Reel	4
	9				
	10				
	11	Logic input 3 polarity		0=Active low 1=Active high	0
	12	Direction setting (available only when no logic input for direction)		0=Count up 1=Count down	0
	13~14	Not used			
15	Must be 1		1=New format logic inputs		

## LOGIC OUTPUTS

### Logic outputs connection

Two outputs are fitted as standard and may be accessed through the following pins:

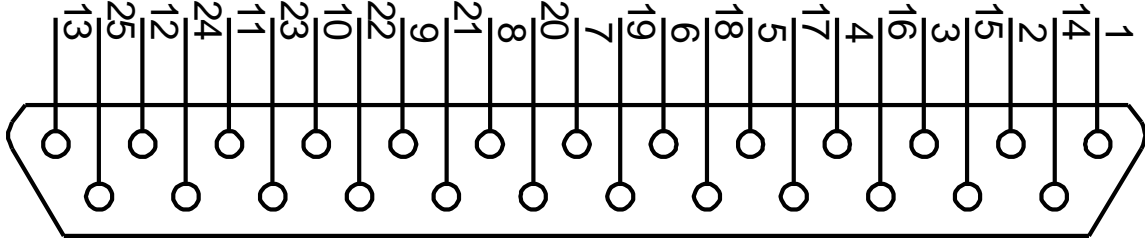

Connector type: DB25 female (socket)

Functional group	Pin	Designation	Description	Notes	
Shield	S	Shield	Shield	Connect to cable and plug shields	
Power supply and ground	2	DGND	Power supply and signal ground (0V)	Floating (inactive) or pull-down to DGND (active)	
	15				
	24				
Logic outputs	6	LOP1	Logic output 1	<b>State</b>	<b>Output</b>
				Inactive	Floating
				Active	Pulled down to DGND
	7	LOP2	Logic output 2	<b>State</b>	<b>Output</b>
				Inactive	Floating
				Active	Pulled down to DGND

### Logic outputs electrical specifications

- The logic outputs must NOT be used to directly drive high-current or inductive loads.
- It is recommended that the logic outputs are used to drive opto-isolated solid-state relays.

Specification	Minimum	Typical	Maximum	Units
Logic output to DGND voltage			+25	VDC
Current			0.1	A

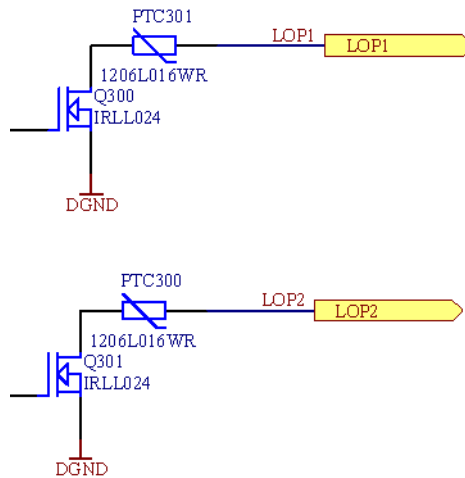

## Logic outputs configuration

Each individual logic output can be independently configured to pull-down to DGND upon any one of the following conditions:

### Configuration via the PCiS\_SLmini software:

- 1 Click the “Interface” button on the main page:

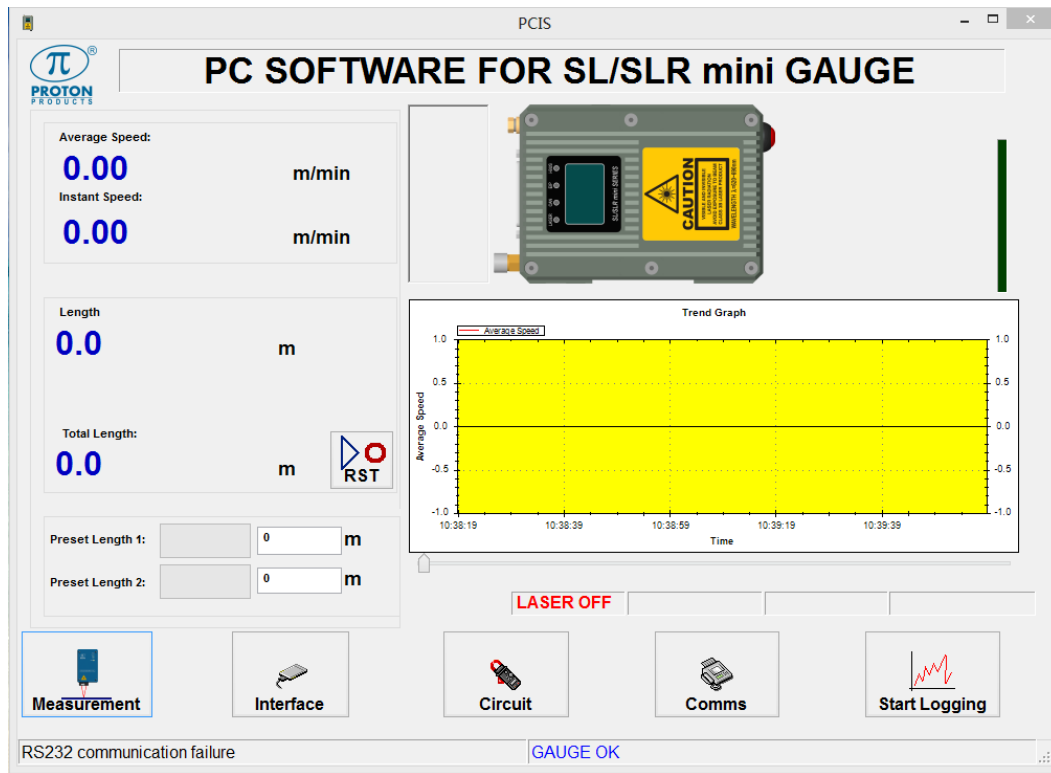

- 2 When prompted, enter 64000 for the password and click the “OK” button:

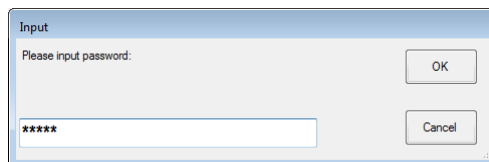

3 | Configure the logic output interface as required and click the “Exit” button when complete:

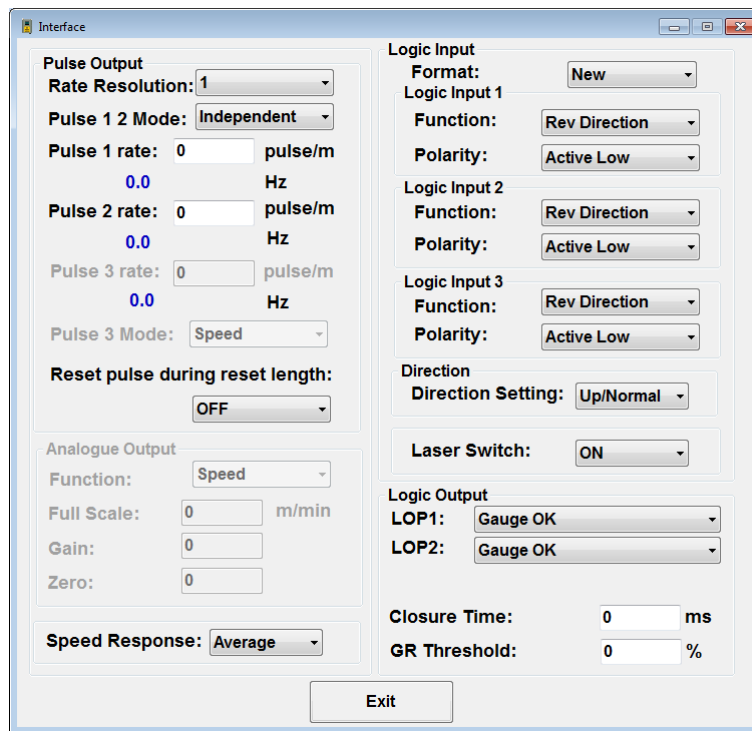

Label	Value*	Description	Input DW	
LOP1	Select the condition to pull-down the logic output:			
	Gauge OK	There are no errors in the operation of the gauge.	16	
	Gauge Measuring Speed	The gauge is measuring speed.		
	Preset Length 1 / Batch Length	Normal mode		The measured length exceeds “Preset Length 1”.
		Batch mode		The measured length equals the “Batch Length” (the logic output is pulled down momentarily for the duration of the “Closure Time” setting below).
	Preset Length 2 / Batch Number	Normal mode		The measured length exceeds “Preset Length 2”.
		Batch mode		The number of measured batch lengths is equal to or greater than the “Batch Number”.
	Good Reading	The “Good Readings” percentage exceeds the “GR Threshold” set below.		
Object Detected	An object has been detected by the gauge.			
Gauge Too Hot	The gauge temperature has exceeded its safe operating limit of 45°C (this output may be used to activate external cooling systems).			
LOP2	As per LOP1	As per LOP1		
Closure Time	10 ~ [500] ~ 5000 ms	Set the minimum pull-down time (in milliseconds) for any logic outputs configured for the “Batch Length” function.	4	
GR Threshold	0 ~ [60] ~ 100 %	Set the threshold above which the “Good Readings” percentage will trigger pull-down of any logic output configured to the “Good Reading” condition.	18	

\* factory-default values are shown in enclosed in [ ].

**Configuration by input parameters:**

This interface may be configured by writing to the following input parameters:

## Input parameters

DW	Bit	Comment	Unit	Range/Remark	Default
4		Batch mode LOP closure time	1=10ms	1~500 (10ms~5s)	50
		<b>Logic output function</b>			
16	0~3	LOP1 function		0=Gauge OK 1=Gauge measuring speed 2=Preset length 1 / Batch length 3=Preset length 2 / Batch number 4=Good reading 5=Object detected 6=Gauge too hot	0
	4~7	LOP2 function			2
	8~15	Not used			3
18		Good Reading threshold	1=1%		60%

## PULSE OUTPUTS

### Pulse outputs connection

Four pulse outputs are fitted as standard and may be accessed through the following pins:

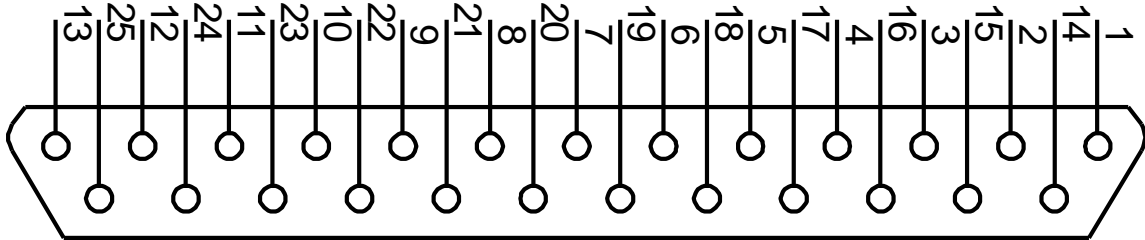

Connector type: DB25 female (socket)

Functional group	Pin	Designation	Description	Notes
Pulse outputs	1	POUT +V	Pulse output external power supply	If no external power supply is connected, then the pulse outputs default to the internal +5V supply. Maximum voltage: +24V
	18	P1A	Pulse output 1	RS-422 compliant differential pair pulse output 1.
	19	/P1A	Inverted pulse output 1	
	20	P2A	Pulse output 2	RS-422 compliant differential pair pulse output 2.
21	/P2A	Inverted pulse output 2		
Power supply and ground	25	+24V	Power supply	For 24V pulse outputs, connect this pin to POUT +V.
	2	DGND	Power supply and signal ground reference	Ground reference for P1A, /P1A, P2A and /P2A.
	15	DGND		
	24	DGND		
Shield	S	Shield	Shield	Connect to cable and plug shields

- RS-422 compliant differential pair (normal and inverse) outputs are provided for pulse outputs “Pulse output 1(P1A, /P1A)” and “Pulse output 2 (P2A, /P2A)”; each pulse output can thus be connected to both single-ended and differential interfaces.
- “Pulse output 1(P1A, /P1A)” and “Pulse output 2 (P2A, /P2A)” default to a 0 to +5V signal range; if a higher output voltage is required, then an external voltage source up to +24VDC may be connected across POUT +V and DGND to define the required voltage.
- “Pulse output 1” and “Pulse output 2” may be user-configured for either independent or quadrature operation.
- In independent mode, “Pulse output 1” and “Pulse output 2” run independently and may be configured with different pulse rates:

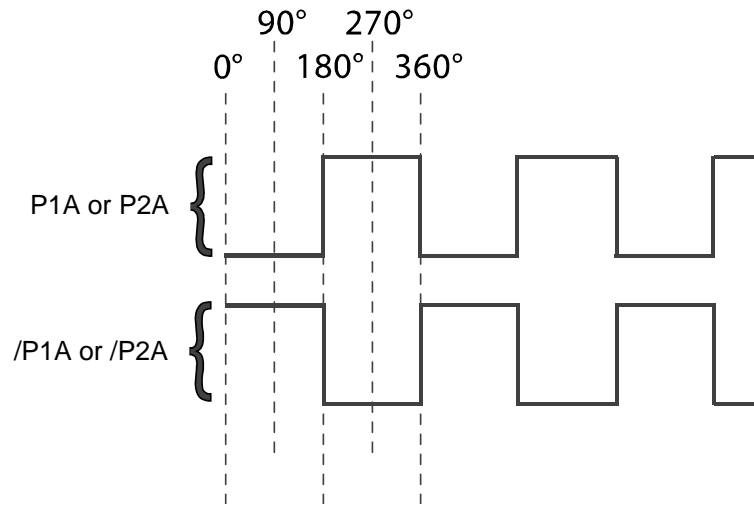

- In quadrature mode, “Pulse output 1” and “Pulse output 2” run at the same pulse rate (set as the “Pulse 1 rate”) with a 90° phase shift between the two outputs:

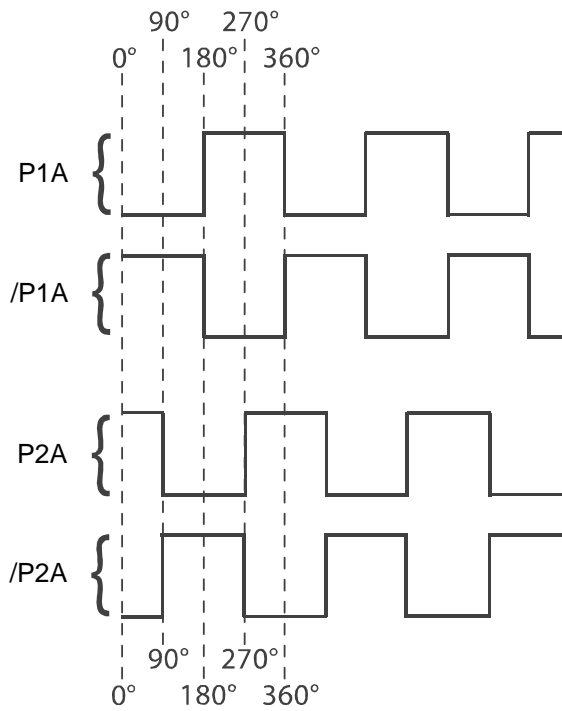

### Pulse outputs electrical specifications

Specification	Minimum	Typical	Maximum	Units
Pulse output external power supply (POUT +V)	+5		+25	VDC
Pulse output frequency			2*	MHz

\* reduced with increasing cable length in accordance with RS-422 standards.



## Configuration via the PCiS\_SLmini software:

- 1 Click the “Interface” button on the main page:

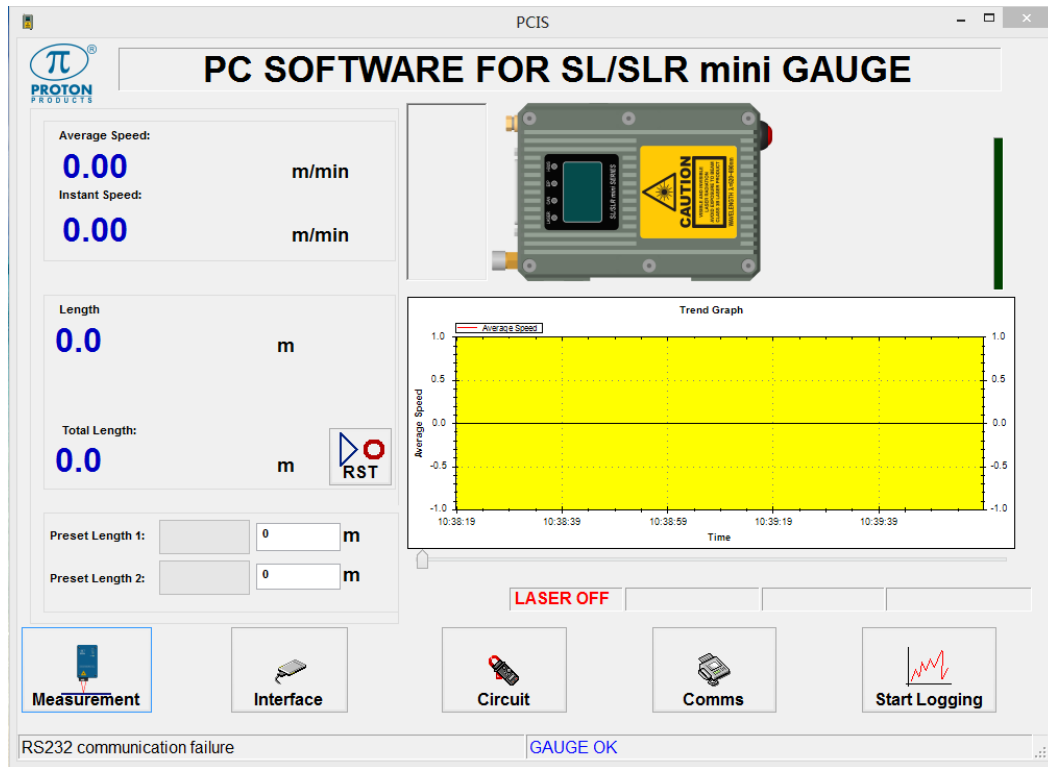

- 2 When prompted, enter 64000 for the password and click the “OK” button:

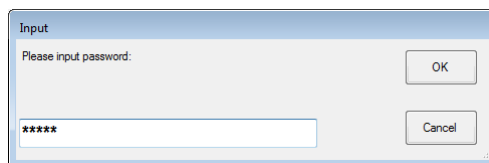

3 | Configure the pulse output interface as required and click the “Exit” button when complete:



Label	Value*	Description
Pulse Resolution	1000	Set the required pulse output resolution in pulses/ unit, where the unit is the “Measurement unit” (metres, feet, inch or yards) set on the “Measurement” page.
	100	
	10	
	[1]	
	0.1	
	0.01	
	0.001	
Pulse 1 2 Mode	[Independent]	Select “Independent” mode to configure “Pulse output 1” and “Pulse output 2” with separate and independent pulse rates.
	Quadrature	Select “Quadrature” mode to couple together “Pulse output 1” and “Pulse output 2” as a quadrature pair, with pulse rate set under “Pulse 1 rate”.
Pulse 1 rate	1 ~ [1000] ~ 65535	Set the required pulse rate for “Pulse output 1” in pulses/unit, where the unit is the “Measurement unit” (metres, feet, inch or yards) set on the “Measurement” page.  <b>Note:</b> If the “Pulse Resolution” setting above is not suitable for the pulse rate entered here, then the pulse rate will be automatically rounded up or down.  When “Pulse 1 2 Mode” is set to “Quadrature”, this parameter sets the rate for the quadrature pulse output across both “Pulse output 1” and “Pulse output 2”.

Pulse 2 rate	1 ~ [1000] ~ 65535	Set the required pulse rate for “Pulse output 2” in pulses/ unit, where the unit is the “Measurement unit” (metres, feet, inch or yards) set on the “Measurement” page.  <b>Note:</b> If the “Pulse Resolution” setting above is not suitable for the pulse rate entered here, then the pulse rate will be automatically rounded up or down.  This field is disabled when “Pulse 1 2 Mode” is set to “Quadrature”.
Reset pulse during reset length	[OFF]	Select for pulse outputs to continue following the measured speed during a length reset.
	ON	Select to reset pulse outputs when the length is reset.

\* factory-default values are shown in enclosed in [ ].

**Configuration by input parameters:**

This interface may be configured by writing to the following input parameters:

DW	Bit	Comment	Unit	Range/Remark	Default
0	9	System Function			
		Pulse output 1 mode		0=Normal 1=Quadrature	0
7		Pulse output 1 rate	1=1/10DW17pulse/m{ft}{yds}	1~65535	1000
8		Pulse output 2 rate	1=1/10DW17pulse/m{ft}{yds}	1~65535	1000
17		Pulse output rate resolution	1=1	3=1000 2=100 1=10 0=1 -1=0.1 -2=0.01 -3=0.001	0
19		Pulse reset during reset length		0=Off 1=On	0

## Circuit Information and Gauge Performance Indicators

The “Circuit” page of the PCiS\_SLmini displays various performance indicators and gauge circuit parameters.

- 1 Click the “Circuit” button on the main page:

The screenshot displays the PC software interface for the SL/SLR mini Gauge. The window title is "PCiS". The main heading is "PC SOFTWARE FOR SL/SLR mini GAUGE".

**Speed Indicators:**  
Average Speed: 0.00 m/min  
Instant Speed: 0.00 m/min

**Length Indicators:**  
Length: 0.0 m  
Total Length: 0.0 m

**Control Buttons:**  
Preset Length 1: 0 m  
Preset Length 2: 0 m  
RST (Reset) button

**Measurement and Interface:**  
Measurement button (highlighted with a blue border)  
Interface button

**System Status:**  
LASER OFF (red text)  
GAUGE OK (blue text)

**Graphs:**  
A "Trend Graph" showing Average Speed vs. Time. The y-axis ranges from -1.0 to 1.0, and the x-axis shows time intervals from 10:38:19 to 10:39:39. The graph area is currently blank and yellow.

**Bottom Navigation:**  
Measurement, Interface, Circuit, Comms, Start Logging buttons.

**Status Bar:**  
RS232 communication failure (red text)

2 The "Circuit" page displays parameters which may be useful during gauge alignment or for Proton Products authorized service personnel; when contacting Proton Products for technical assistance, please have the information displayed on the "Circuit" page available for our service personnel to better diagnose any problems.

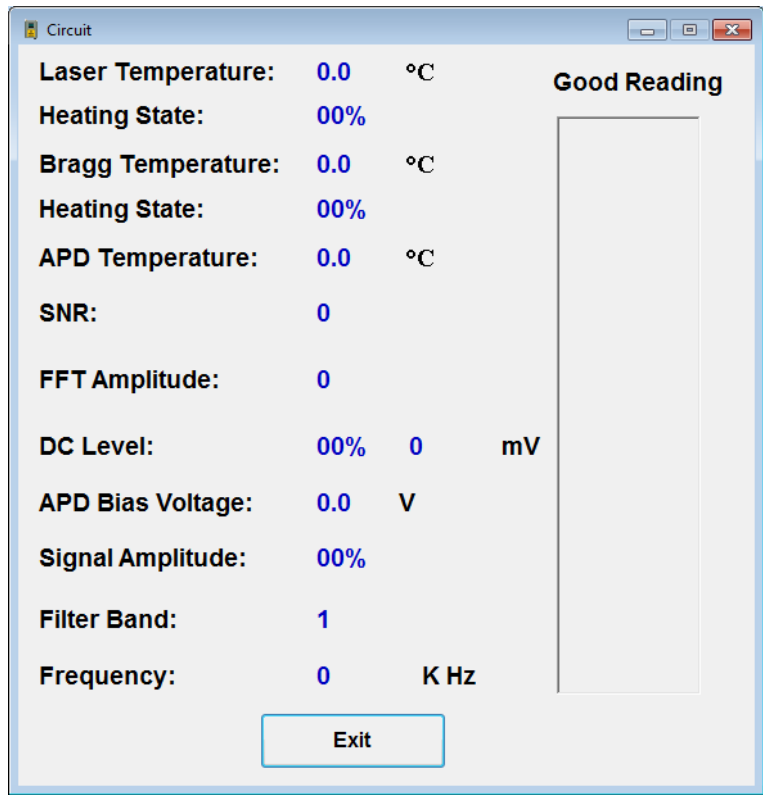

Label	Description	Min	Typ	Max	Units
Good Reading	The gauge attempts to sample the speed of the object several thousand times per second; the "Good Reading" rate represents the proportion of samples that have yielded a valid speed reading.				14
	Higher "Good Reading" rates result in better length accuracy, especially over shorter object lengths.				
	If the surface of the object is irregular then different areas may yield different "Good Reading" rates.				
	For smooth surfaces a "Good Reading" rate above 50% will produce speed and length readings of reliably high accuracy.				
	In short-length measurement applications (such as inkjet-marking or cutting, with lengths in the range of a few metres), a "Good Reading" rate of above 80% is recommended to maintain good length accuracy.				
	Long length (> 5 m) accuracy	50	70	100	%
	Short length (0 ~ 5 m) accuracy	80	90	100	%

SNR	<p>This parameter is highly-dependent on object material, object distance to the centre of the depth-of-field and object speed.</p> <p>For example, a metal or matt-plastic surface moving at 100 m/minute may return a SNR &gt; 1000, but the SNR for a translucent plastic object may be much lower.</p> <p>The signal-to-noise ratio must exceed 80 for a consistent and reliable speed reading.</p>	200	500		-
DC Level (%)	<p>The DC level depends on the amount of light received from the object and must be between 10% and 90% for correct operation; it is held at around 30% by an automatic gain controller (AGC).</p> <p>The AGC may be saturated by highly reflective (e.g. flat, metallic) surfaces resulting in the DC level exceeding 100%; in this case tilt the gauge (pitch, angle <math>\gamma \neq 0</math>) to reduce the received light and bring the DC level below 90%.</p> <p>Very narrow or low-reflectivity objects might not reflect sufficient light for the DC level to reach 10%; maximise the signal by locating the object as close to the stand-off distance (i.e. centre of the depth-of-field).</p>	10	30	90	%
Signal Amplitude	<p>Highly-reflective, uneven or fast-moving objects may result in saturation and clipping of the received oscillating light signal.</p> <p>Signal amplitudes below 80% will not incur saturation, whilst an Automatic Gain Controller (AGC) will accommodate signal amplitude between 80 and 99%. Signal amplitudes above 99% will still yield measurements but at a substantially degraded Good Reading rate.</p> <p>Maintain the signal amplitude at below 80% by tilting the gauge (pitch, angle <math>\gamma \neq 0</math>) to reduce the received light.</p>			80	%
Laser Temperature	For use by Proton Products authorized service personnel only.				°C
Heating State					%
Bragg Temperature					°C
Heating State					%
APD Temperature					°C
FFT Amplitude					-
DC Level (mV)					mV
APD Bias Voltage					V
Filter Band					-
Frequency					kHz

# DATA LOGGING

The data logging function logs measurement data at regular time intervals to a .csv (comma separated values) text file which may be opened using MS Excel and other spreadsheet software.

- 1 Click the “Start Logging” button on the main page:

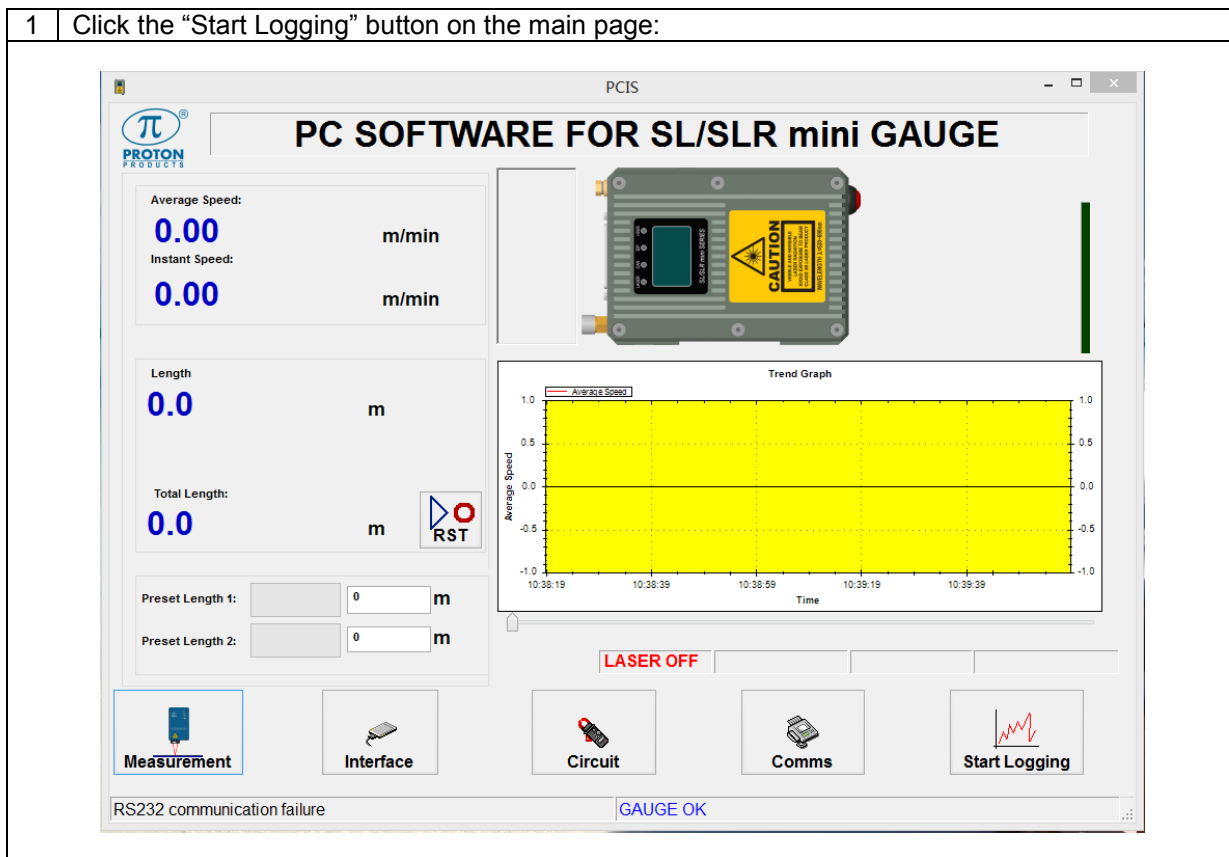

2 Select the required parameters to log to file, the logging time interval, file name and start/stop logging:

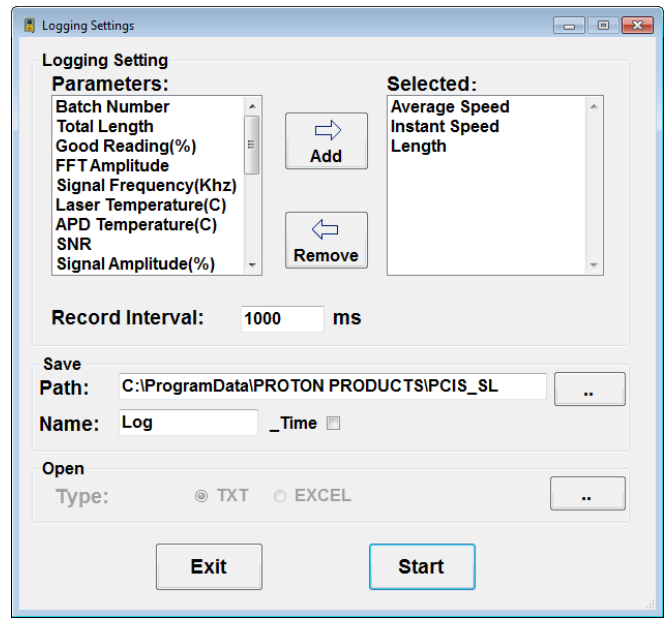

Label	Description
Parameters	This displays the parameters that are available for logging; click to highlight a parameter in this list and then click the “Add” button to move the highlighted parameter to the “Selected” list.
Selected	This displays the parameters selected for logging; click to highlight a parameter in this list and then click the “Remove” button to move the highlighted parameter back to the “Parameter” list.
Add	Click this button to move a highlighted parameter from the “Parameters” list to the “Selected” list.
Remove	Click this button to move a highlighted parameter from the “Selected” list to the “Parameters” list.
Record Interval	Enter the interval time (in milliseconds) at which data is written to the log file.
Path	Click the “...” button to edit the path to the log file.
Name	Click to edit the name of the log file.
_Time	<input checked="" type="checkbox"/> Ticked   Append the start time to the name of the log file.
	<input type="checkbox"/> Unticked   Do not append the start time to the name of the log file.
Start	Click to commence data logging.
Stop	Click to stop data logging.
Exit	Click to close this dialog box and return the main page.



## CONNECTOR PIN OUTS

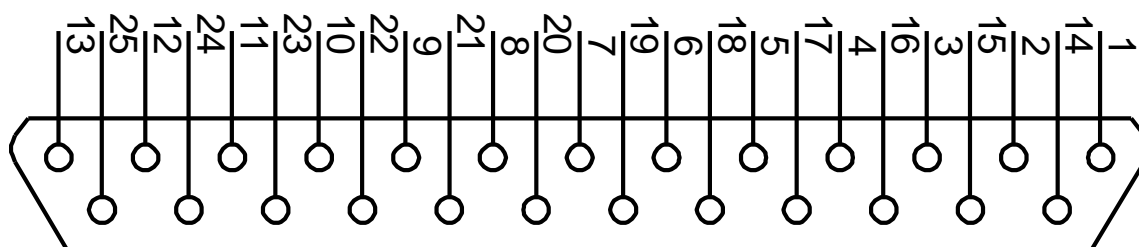

Connector type: DB25 female (socket)

Functional group	Pin	Designation	Description	Notes
Logic inputs	3	LIN1	Logic input 1	Low < +3V; High > +10.5V; Max ±30V User configurable function.
	4	LIN2	Logic input 2	
	5	LIN3	Logic input 3	
Logic outputs	6	LOP1	Logic output 1	Floating or pull-down; user configurable function.
	7	LOP2	Logic output 2	
CANbus	8	CAN H	CANbus high	For connection to Proton Products accessories.
	9	CAN L	CANbus low	
Laser safety	12	SHUT_ST	Shutter status	Pulled down to DGND when the shutter is open.
	13	/SHUT_EN	Shutter control	Pull down to DGND to open the laser shutter.
	14	/LSR_EN	Laser enable	Pull down to DGND to enable the laser diode.
RS-232	16	RXD	RS-232 receive	
	17	TXD	RS-232 transmit	
Pulse outputs	1	POUT +V	Pulse output external power supply	If no external power supply is connected, then the pulse outputs default to the internal +5V supply.
	18	P1A	Pulse output 1	RS-422 compliant differential pair outputs. Pulse outputs 1 and 2 may be user-configured for independent or quadrature operation.
	19	/P1A	Inverted pulse output 1	
	20	P2A	Pulse output 2	
21	/P2A	Inverted pulse output 2		
	25	+24V	Power supply	Operating voltage: 15 to 28VDC Power consumption: 15W
	2	DGND	Power supply and signal ground reference	
	15	DGND		
	24	DGND		
Shield	S	Shield	Shield	Connect to cable and plug shields

Functional group	Pin	Designation	Industrial bus option		
			Ethernet EtherNet/IP	PROFIBUS	DeviceNET
Industrial bus	22	IBUS1	TX+	+5V	V+
	10	IBUS2	TX-	GND	V-
	23	IBUS3	RX+	A	CANH
	11	IBUS4	RX-	B	CANL

## OPTIONAL PSU-BOB MINI

The Proton Products PSU-BOB mini (Power Supply Unit-Break Out Box-mini) is an optional accessory for the SL mini / SLR mini series of laser speed and length gauges which provides the following functions:

- Universal AC to DC power supply
- DB9 connectors for CANbus, RS-232 and optional PROFIBUS / DeviceNET communications interfaces
- RJ45 socket for Ethernet MODBUS or optional Ethernet/IP communications interface
- Laser enable key switch
- Screw terminals for logic inputs, logic outputs, pulse outputs and laser safety connections



The SL mini / SLR mini gauge may be connected to the PSU-BOB mini using one of the following optional DB25-to-DB25 cables:

Length / m	Part name	Proton part no
3	SLMKII-BOB-003	00043MC021
5	SLMKII-BOB-005	00041CT005
10	SLMKII-BOB-010	00041CT010
20	SLMKII-BOB-020	00041CT020
30	SLMKII-BOB-030	00041CT030

## CAN

Connector type: DB9 male (plug)

Pin	Designation	Comment
2	CANL	
3	GND	Ground reference (isolated from earth / shield).
5	Shield	Ensure that the cable shield is connected to this via the plug shield connection.
7	CANH	
9	+24V	+24VDC power input (the gauge may be powered via this pin).
S	Shield	Ensure that the cable shield is connected to the plug shield connection.

## RS232

Connector type: DB9 female (socket)

Pin	Designation	Comment	PC DB9 serial port pin
2	TXD1		2
3	RXD1		3
5	GND_R	Ground reference is not isolated from earth.	5

Pin	Designation	Comment	PC DB9 serial port pin
7	CTS1		Not used
8	RTS1		Not used
S	Shield	Ensure that the cable shield is connected to this via the plug shield connection.	Shield

The above table also shows the configuration of a cable for connection to a personal computer (PC) type DB9 serial port.

## I-BUS

Connector type: DB9 female (socket)

PROFIBUS			
Pin	Function	Comments	
3	B		
5	GND		
6	+5V		
8	A		
S	Shield	Ensure that the cable shield is connected to this via the plug shield connection.	

DeviceNet			
Pin	Function	Wire colour	Comment
3	CANL	Blue	
5	V-	Black	
6	V+	Red	
8	CANH	White	
S	Shield		Ensure that the cable shield is connected to this via the plug shield connection.

Ethernet / EtherNet/IP / PROFINET			
Pin	Function	Comments	
1	LAN TX-		
2	LAN TX+		
7	LAN RX-		
9	LAN RX+		
S	Shield	Ensure that the cable shield is connected to this via the plug shield connection.	

**Note:** for Ethernet, EtherNet/IP and PROFINET communications interfaces, the i-BUS DB9 socket and RJ45 socket are wired in parallel; either one or the other connector may be used depending on the available cable plug type.

## RJ45 SOCKET

Connector type: RJ45 8P8C female (socket)

Ethernet / EtherNet/IP / PROFINET			
Pin	Function	Comments	
1	LAN TX+		
2	LAN TX-		
3	LAN RX+		
6	LAN RX-		
S	Shield	Ensure that the cable shield is connected to this via the plug shield connection.	

**Note:** for Ethernet, EtherNet/IP and PROFINET communications interfaces, the i-BUS DB9 socket and RJ45 socket are wired in parallel; either one or the other connector may be used depending on the available cable plug type.

## SCREW TERMINALS

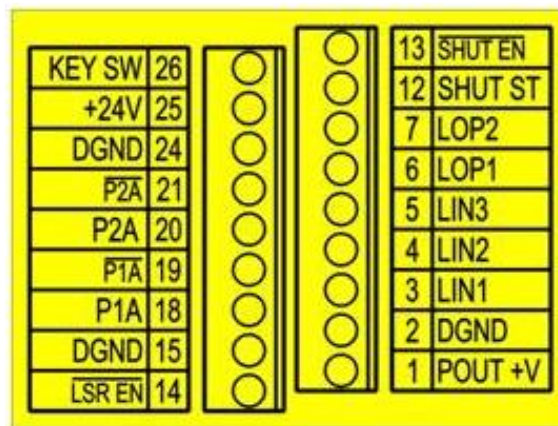

Connector type: Screw terminals

Functional group	Screw terminal*	Designation	Description	Notes
Logic inputs	3	LIN1	Logic input 1	Low < +3V; High > +10.5V; Max ±30V User configurable function.
	4	LIN2	Logic input 2	
	5	LIN3	Logic input 3	
Logic outputs	6	LOP1	Logic output 1	Floating or pull-down; user configurable function.
	7	LOP2	Logic output 2	
CANbus	8	CAN H	CANbus high	For connection to Proton Products accessories.
	9	CAN L	CANbus low	
Laser safety	12	SHUT_ST	Shutter status	Pulled down to DGND when the shutter is open.
	13	/SHUT_EN	Shutter control	Pull down to DGND to open the laser shutter.
	14	/LSR_EN	Laser enable	Pull down to DGND to enable the laser diode.
RS-232	16	RXD	RS-232 receive	
	17	TXD	RS-232 transmit	
Pulse outputs	1	POUT +V	Pulse output external power supply	If no external power supply is connected, then the pulse outputs default to the internal +5V supply.
	18	P1A	Pulse output 1	RS-422 compliant differential pair outputs. Pulse outputs 1 and 2 may be user-configured for independent or quadrature operation.
	19	/P1A	Inverted pulse output 1	
	20	P2A	Pulse output 2	
21	/P2A	Inverted pulse output 2		
	25	+24V	Power supply	Operating voltage: 15 to 28VDC Power consumption: 15W
	2	DGND	Power supply and signal ground reference	
	15	DGND		
	24	DGND		
Shield	S	Shield	Shield	Connect to cable and plug shields
Key-switch	26	KEY SW	Laser enable key-switch	This terminal is connected via the key-switch to DGND. A removable jumper connects this terminal to the /LSR_EN (14) terminal.

\* screw terminal numbering corresponds to the pin numbering for the DB25 INTERFACE connector on the gauge.

## KEY SWITCH

The key switch is provided for compliance with laser safety regulations.

- When the key switch is in the open-circuited (“O”) the laser diode in the gauge is DISABLED for laser emission.
- When the key switch is in the short-circuited (“I”) the laser diode in the gauge is ENABLED for laser emission.
- After the key switch is set to the enabled (“I”) position, a warm up period is required to for the laser diode to stabilise before measurements may be taken. The key-switch is intended for intermittent use such as locking out the laser at the end-of-shift or during line maintenance.
- A removable shorting-link connects the LSR\_EN pin via the key-switch to DGND; removal of this shorting link disables the key-switch and permits an external, user-supplied interlock switch to be wired in place of the key-switch.

# DIMENSIONAL DRAWING

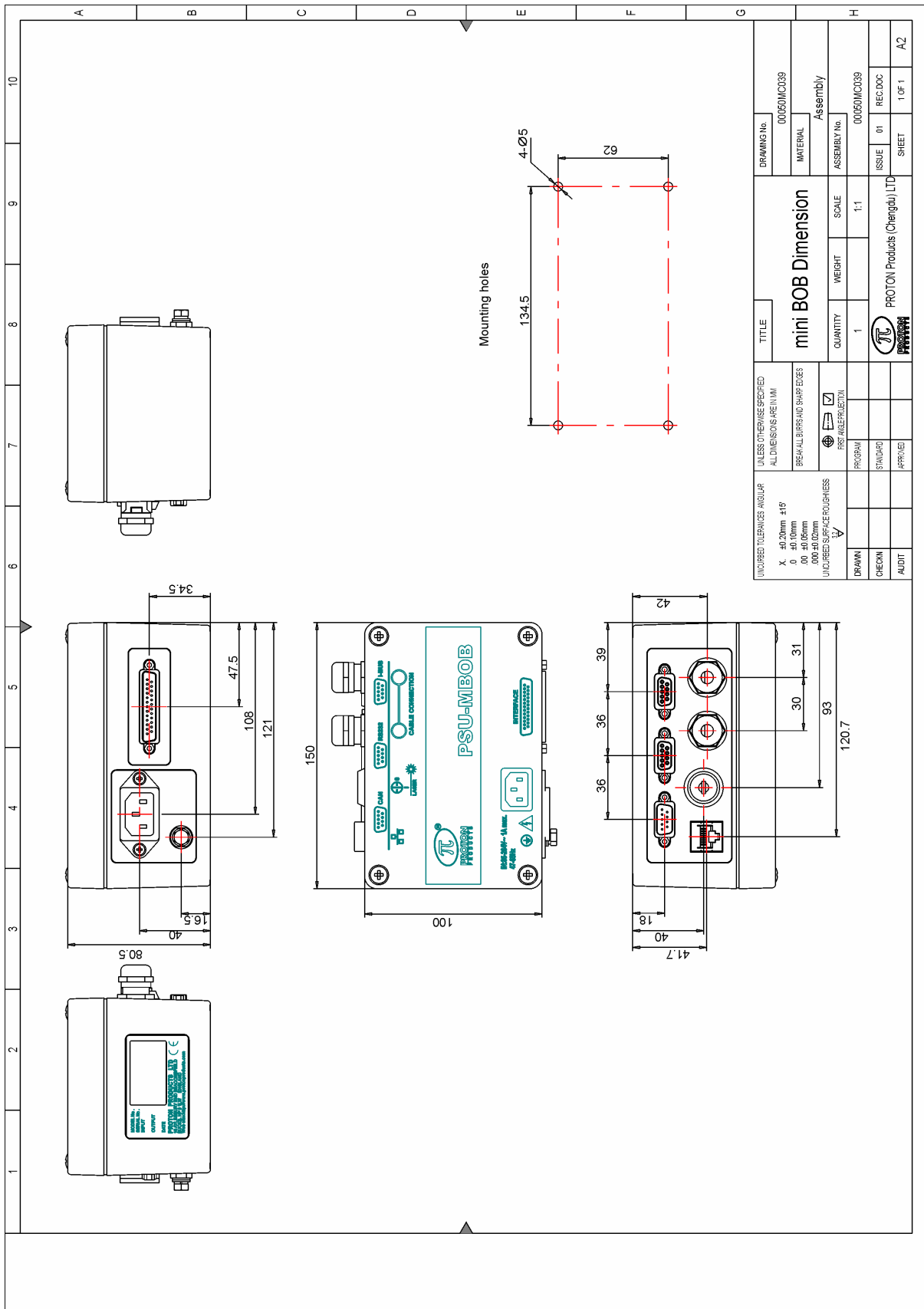

# INPUT PARAMETERS

1 DW word = 2 bytes

2013.08.26

DW	Bit	Comment	Unit	Range/Remark	Default	
0		System Function				
	0	Measurement mode		0=Normal mode 1=Batch mode	0	
	1	Length reset		0=Reset length to zero 1=Accumulate length	1	
	2	Batch length reset (available in batch mode only)		0=Reset length to zero 1=Accumulate length	1	
	3	Measurement unit		0=metres 1=feet 2=yards 3=other unit(set on PCIS)	0	
	4					
	5	Speed signal output response		0=Averaged 1=Instantaneous	1	
	6	Pulse output 3 mode		0=Speed 1=Length	0	
	7	Analogue output source		0=Speed 1=Good Readings	0	
	8	Length / speed resolution		0=Length 0.1 / speed 0.01 1=Length 0.0001 / Speed 0.001	1	
	9	Pulse output 1 mode		0=Normal 1=Quadrature	0	
	10	Automatic save length function		0=Invalid 1=Valid	0	
	11	Object detection switch		0=Off 1=On	0	
	12	Auto reset when object detected		0=Off 1=On	0	
	13	Reset reel number		0=Normal 1=Reset reel number to zero	0	
	14-15	Not used			0	
1		Preset 1 and 2 decimal point position		-3-3	0	
2		Averaging time	1=5ms	1~1000 (5-5000ms)	200	
3		No speed signal hold time	1=1ms	1~5000 (1ms-5s)	100	
4		Batch mode LOP closure time	1=10ms	1~500 (10ms-5s)	50	
5		Preset length 1 or Preset batch length	1=1/10DW1m{ft}{yds}{inch}	0-65535	1000	
6		Preset length 2 or Preset batch number	1=1/10DW1m{ft}{yds}{inch} 1=1(batch number)	0-65535	2000	
7		Pulse output 1 rate	1=1/10DW17pulse/m{ft}{yds}	1~65535	1000	
8		Pulse output 2 rate	1=1/10DW17pulse/m{ft}{yds}	1~65535	1000	
9		Pulse output 3 rate	1=1/10DW17pulse/m{ft}{yds}	1~65535	1000	
10		Analogue output full scale	1=1m/min{ft/min}	100-9999	3000	
11		Minimum speed limit	1=0.1m/min{ft/min}	0-65535 (0-6553.5)	0	
		<b>Logic input (old format: compatible with old SL gauge; DW12.15=0)</b>				
	0	Logic input 1 function		0=Direction 1=Length hold 2=Display hold 3=Speed hold	1	
	1					
	2	Direction setting (available only when no logic input for direction)		0=Count up 1=Count down	0	
	3	Logic input 1 polarity		0=Active low 1=Active high	0	
	4-7	Not used			0	
	8	Logic input 2 function		0=Reset input 1=Length hold	0	
	9					
	10	Logic input 2 polarity		0=Active low 1=Active high	0	
	11	Logic input 3 function		0=Direction 1=Length hold 2=Display hold	1	
	12					
	13					

DW	Bit	Comment	Unit	Range/Remark	Default
				3=Speed hold 4=Reset	
	14	Logic input 3 polarity		0=Active low 1=Active high	0
	15	Must be 0		0=Old format logic inputs	0
		<b>Logic input(new format;DW12.15=1)</b>			
12	0	Logic input 1 function		0=Direction (count down) 1=Length hold 2=Display hold 3=Speed hold 4=Reset total length 5= End of Reel / Reset batch length	0
	1				
	2				
	3	Logic input 1 polarity		0=Active low 1=Active high	0
	4	Logic input 2 function		0=Direction (count down) 1=Length hold 2=Display hold 3=Speed hold 4= Reset total length 5=End of Reel / Reset batch length	1
	5				
	6				
	7	Logic input 2 polarity		0=Active low 1=Active high	0
	8	Logic input 3 function		0=Direction (count down) 1=Length hold 2=Display hold 3=Speed hold 4= Reset total length 5= End of Reel / Reset batch length	4
	9				
	10				
	11	Logic input 3 polarity		0=Active low 1=Active high	0
12	Direction setting (available only when no logic input for direction)		0=Count up 1=Count down	0	
13~14	Not used				
15	Must be 1		1=New format logic inputs		
13		Laser switch		0=Laser on 1=Laser off	0
14		Length offset	1=0.1m{ft}{yds}{inch}	-3000.0~3000.0m{ft}{yds}	0
15		Pulse output 3 preset length	1=0.001m{ft}{yds}		1000
		<b>Logic output function</b>			
16	0~3	LOP1 function		0=Gauge OK	0
	4~7	LOP2 function		1=Gauge measuring speed 2=Preset length 1 / Batch length 3=Preset length 2 / Batch number 4=Good reading 5=Object detected 6=Gauge too hot 13=User 1 14=User 2 15=User 3	2
	8~11	LOP3 function			3
	13	User I/P 1		0=OPEN 1=CLOSE	
	14	User I/P 2		0=OPEN 1=CLOSE	
15	User I/P 3		0=OPEN 1=CLOSE		
17		Pulse output rate resolution	1=1	3=1000 2=100 1=10 0=1 -1=0.1 -2=0.01 -3=0.001	0
18		Good Reading threshold	1=1%		60%
19		Pulse reset during reset length		0=Off 1=On	0
20		Profibus address	1=1	0~125	7



DW	Bit	Comment	Unit	Range/Remark	Default
21		CAN address	1=1	0-255	14
22		CAN baud rate		0=250 1=500 2=1000 other=500	2
23		RS232 baud rate		0=4800 1=9600 2=19200 3=38400 4=115200	1
24		RS232 mode		0=Proton protocol 1=Modbus protocol 2=ZM400 Printer	1
25		RS422/RS485 mode		0=Proton protocol 1=Modbus protocol 2=SSI speed protocol 3=SSI length protocol	1
26		RS422/RS485 baud rate		0=4800 1=9600 2=19200 3=38400 4=115200 5=250K 6=500K 7=1M	1
27		Modbus address	1=1	0-255	1
28		EtherNet protocol		0=Modbus protocol 1=EIP protocol	0
29		DHCP		0=Disabled 1=Enabled	0
30		IP address	x.x.x.x		C0A8016E (192.168.1.110)
31					
32		Subnet mask	x.x.x.x		FFFF0000 (255.255.0.0)
33					
34		Gateway	x.x.x.x		C0A80001 (192.168.1.1)
35					
36		CAN terminator	1=1	0=Off 1=On	0
37					
38		Speed compensation coefficient	1=0.0001		10000
39		Acceleration limit	1=1m{ft}{yd}/min/s	1-9999	9999
40		Reset parameters to factory defaults		63000=factory default other=invalid	
41		UDP data output interval time	1=1ms	1-5000 0=Disable UDP output	0
42		Analogue O/P gain	1=0.0001		9999
43		Analogue O/P zero	1=0.0001		0
44		Speed simulation		0=Normal 1=Simulation	0
45		Simulation speed	1=0.1m{ft}{yds}/min	0-6553.5	100
46		DeviceNet address		0-63	7
47		DeviceNet baud rate		0=125K 1=250K 2=500K	
48		UDP destination IP address (last octet only)		<b>Note:</b> the UDP destination port number is fixed at 1111	2
49		Endianess		1=Little endian 0=Big endian	0

# OUTPUT PARAMETERS

1 DW word = 2 bytes

2013.08.26

DW	Bit	Comments	Units	Range/Remark
0	0	Mode		0=Normal 1=Batch
	1	Length / speed resolution		0=Length 0.1 / speed 0.01 1=Length 0.0001 / speed 0.001
	2	Not used		
	3	Measured length >= Preset1		1=>Preset
	4	Measured length >= Preset2		1=>Preset
	5	Length reset		0=Reset
	6	Measurement unit		0=Metres 1=Feet 2=Yards 3=other unit (set on PCIS)
	7			
	8	Speed signal output response		0=Averaged 1=Instantaneous
	9			
	10	Laser status		1=Laser on 0=Laser off
	11	Gauge OK		1=Gauge OK
	12	Speed reading validity		1=Valid 0=Invalid
	13	Object detected		1=Object detected 0=No object
	14	Good reading status		1=Lower than threshold 0=OK
15	Not used			
1	0	Gauge OK		1=Error 0=OK
	1	Laser temperature too high		1=Too high 0=OK
	2	Laser temperature too low		1=Too low 0=OK
	3	APD temperature too high		1=Too high 0=OK
	4	APD temperature too low		1=Too low 0=OK
	5	APD DC level		1=Too high 0=OK
	6	Gauge too hot		1=Too hot 0=OK
	7	Not used		
8	Not used			
2	Average speed			±10~999999 (0.10~9999.99)
3			<b>Old format:</b> 1=0.01m/min {ft/min} {yds/min}	
4	Instant speed			±10~999999 (0.10~9999.99)
5			<b>New format:</b> 1=0.001m/min{ft/min}{yds/min}	
6	Total length / Batch length (when in batch mode)			±200,000.0000
7			<b>Old format:</b> 1=0.1m{ft}{yds}{inch}	
		<b>New format:</b> 1=0.0001m{ft}{yds}{inch}		
8		<b>Logic input</b>		
	0	Not used		
	1	Direction		0=Count up 1=Count down
	2	Logic input 1 function		0=Direction 1=Length hold 2=Display hold 3=Speed hold
	3			
	4		Logic input 1 state	1=Active
	5-7			
	8	Logic input 2 function		0=Reset input 1=Length hold
	9			
	10	Logic input 2 state	1=Active	
	11	Direction		0=Count up 1=Count down
	12	Length hold		1=Hold
	13	Display hold		1=Hold
	14	Speed hold		1=Hold

DW	Bit	Comments	Units	Range/Remark
	15	Length reset		1=Reset
9		Not used		
10		Batch number	1=1	
11		Not used		SNR
12		Total length	1=0.1m{ft}{yds}{inch}	±200,000.0000
13				
14		Good readings percentage	1=1%	0~100
15		Not used		Signal amplitude
16		Not used		
17		Not used		
18		Not used		
19		Not used		
20		i-BUS communications bus type		0=Modbus_TCP 1=PROFIBUS 2=DeviceNET 3=Ethernet/IP 4=PROFINET
21		DHCP		0=Enable 1=Disable
22		IP address	x.x.x.x	
23				
24		Subnet mask	x.x.x.x	
25				
26		Gateway	x.x.x.x	
27				
28		Not used		
29		Not used		

## APPENDIX 1: HIGH ACCURACY LENGTH MEASUREMENT OF DISCRETE OBJECTS APPLICATION NOTE

### PROBLEM

Length measurement of discrete objects moving on a production line may incur errors due to the tracking delay / hold time of the SL / SLR / SL mini / SLR mini gauge as individual objects enter and leave the gauge measurement spot.

### SOLUTION

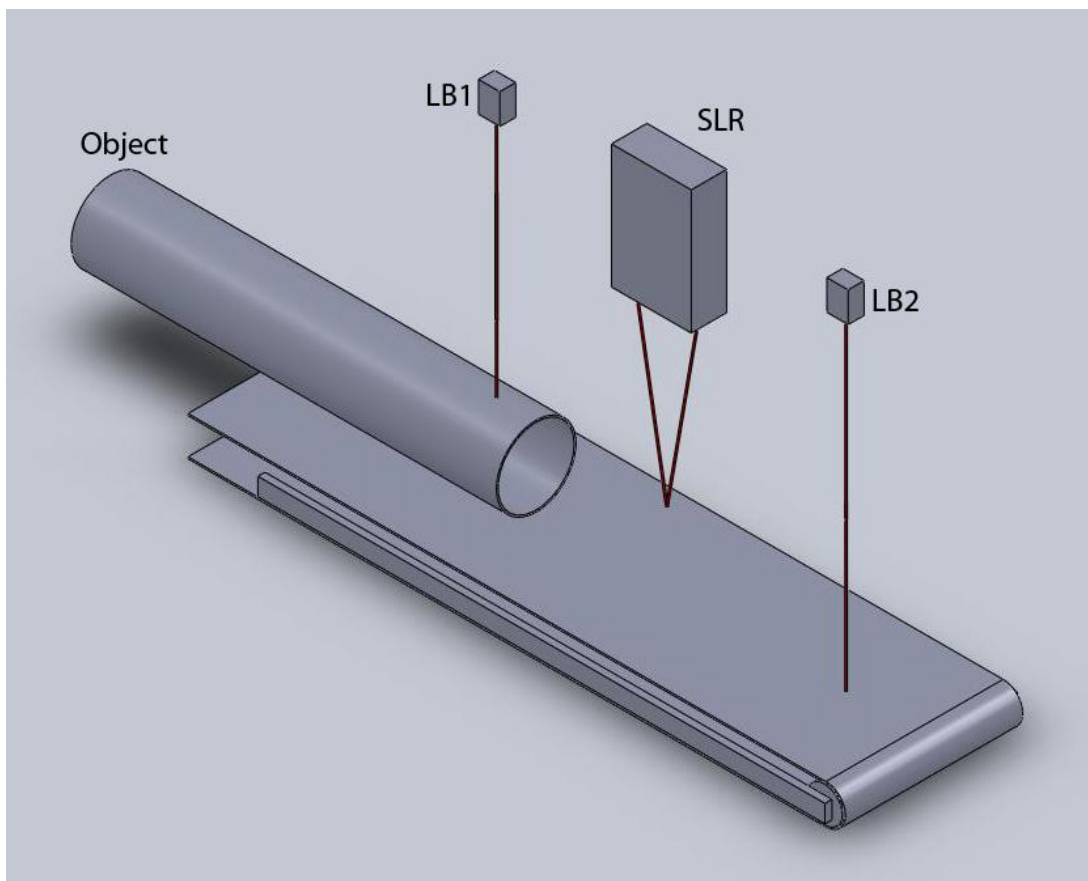

Use two accurately spaced light barriers connected to the logic inputs of the gauge to trigger length measurement only after the object is in position for accurate speed measurement by the gauge.

One light barrier (LB1) is installed upstream of the gauge and one light barrier (LB2) is installed downstream of the gauge. "L" is the accurately measured distance between LB1 and LB2.

The gauge is configured to measure length only when **both** LB1 **and** LB2 are interrupted by the object. The gauge thus measures the length of the object minus a section corresponding to the distance between LB1 and LB2:

$$\text{Object length} = L + (\text{gauge measured length})$$

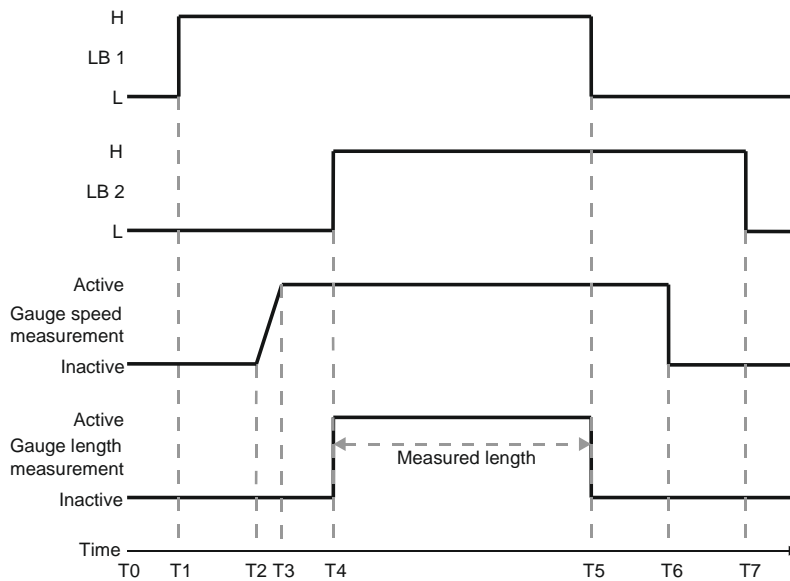

Time	Object status	LB1	LB2	SL / SLR status
T <sub>0</sub>	Clear of LB1, LB2, SL / SLR	Clear	Clear	No object
T <sub>1</sub>	Leading edge interrupts LB1	Blocked	Clear	No object
T <sub>2</sub>	Leading edge enters gauge measurement spot	Blocked	Clear	Object detected but speed measurement not yet valid
T <sub>3</sub>	-	Blocked	Clear	Speed measurement valid (but not displayed/output in "Length hold" mode)
T <sub>4</sub>	Leading edge interrupts LB2	Blocked	Blocked	Length measurement starts
T <sub>5</sub>	Trailing edge clears LB1	Clear	Blocked	Length measurement ends
T <sub>6</sub>	Trailing edge clears gauge measurement spot	Clear	Blocked	Speed measurement ends
T <sub>7</sub>	Trailing edge clears LB2	Clear	Clear	No object

The distance between the gauge gauge and LB2 must be large enough to allow the gauge sufficient time to generate valid speed measurements before the object reaches LB2 and triggers length measurement. Distance "L" between LB1 and LB2 must also be less than the minimum object length.

## IMPLEMENTATION

Light barriers LB1 and LB2 can be connected to any 2 of the 3 logic inputs provided on the gauge. The behaviour of the gauge can be configured to trigger length measurement only when **both** LB1 and LB2 are blocked.

Both logic inputs should be configured to "Length hold" mode. An **active** logic input in "Length hold" mode will cause the gauge to freeze length readings and force the displayed speed to zero (however, internally the gauge will continue to accurately measure speed if an object is present). Hence each logic input should be configured to be **active** when its corresponding light barrier is **clear**.

A "Length offset" corresponding to the distance "L" between the two light barriers can also be programmed in to gauge. The gauge will then automatically add this "Length offset" to its length measurement display and output.

The length measurement generated by the gauge will be ready to read by other production control equipment when the output of LB1 transitions from blocked-to-clear (the object's trailing edge passes through LB1). A momentary pulse may be sent to the third logic input on the gauge to reset the length measurement once it has been read out by other production control equipment.

## Connections to the SL / SLR / SL mini / SLR mini gauge

SL / SLR / SL mini / SLR mini gauges provide three user configurable logic inputs to connect to light barriers LB1 and LB2 and also to a reset pulse input from other production control equipment for resetting the length measurement. Access to these inputs is either via:

1. The DB25 INTERFACE socket on the gauge.
2. The screw terminal board in an optional PSU-BOB-SL combination power supply and breakout box (for SL and SLR gauges) or a PSU-BOB-SL-mini (for SL mini and SLR mini gauges).

Pin / Screw	Designation	Designation full name	Suggested application
3	LIN 1	Logic input 1	LB1 – Length hold mode
4	LIN 2	Logic input 2	LB2 – Length hold mode
5	LIN 3	Logic input 3	Reset length measurement pulse (no shorter than 1ms in duration)
15	DGND	Digital ground	Ground reference for LB1 and LB2

Power for +24VDC light barriers may be derived from the +24VDC power rail of the gauge:

Pin / Screw	Designation	Designation name	Suggested application
24	REG. GND	Power rail ground	SL / SLR User must externally connect this pin to DGND (pin 15) if used to power +24VDC light barriers
			SL mini / SLR mini Already internally connected inside the SL mini / SLR mini to DGND (pin 15).
25	+24V	+24VDC power rail	May be used to power +24VDC light barriers.

### DB25 INTERFACE Socket Logic Input Pin Designations

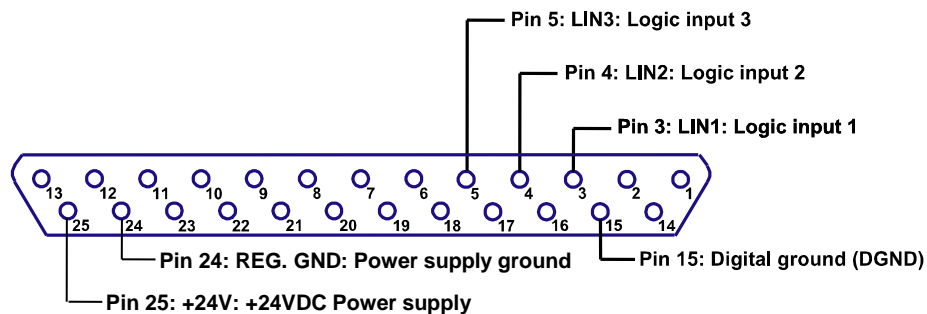

Connector type: DB25 Female Socket

### PSU-BOB-SL Screw Terminal Designations (for SL and SLR gauges only):

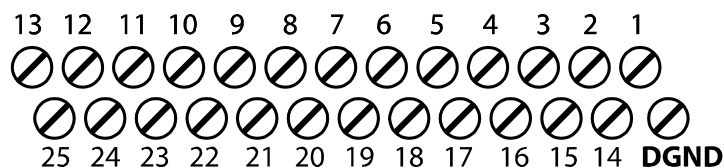

PSU-BOB-SL screw terminal numbers correspond directly to DB25 interface socket pin numbers.

In addition to screw terminal 15, an additional Digital Ground (DGND) terminal is provided on the PSU-BOB-SL screw terminal board.

## PSU-BOB-SL-mini Screw Terminal Designations (for SL mini and SLR mini gauges only):

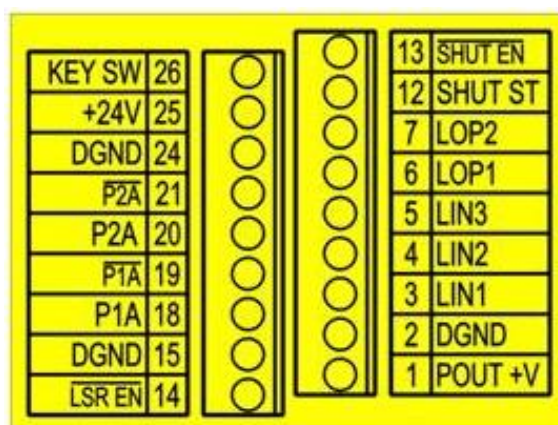

Connector type: Screw terminals

Functional group	Screw terminal	Designation	Description	Notes
Logic inputs	3	LIN1	Logic input 1	Low < +3V; High > +10.5V; Max $\pm 30V$ User configurable function.
	4	LIN2	Logic input 2	
	5	LIN3	Logic input 3	
	25	+24V	Power supply	Operating voltage: 15 to 28VDC Power consumption: 15W
	2	DGND	Power supply and signal ground reference	
	15	DGND		
	24	DGND		

PSU-BOB-SL-mini screw terminal numbers correspond directly to DB25 interface socket pin numbers.

### Logic input electrical characteristics

- Logic inputs are referenced to pin 15 (DGND). Pin 15 is internally connected to the enclosure earth so all voltages are also referenced to earth.
- A low state (logic 0) is defined as a voltage below +3V.
- A high state (logic 1) is defined as a voltage above +10.5V.
- The safe input voltage range is  $-30V$  to  $+30V$ .
- All inputs are internally pulled up via a  $5.1k\Omega$  resistor to an internal +15V source, thus inputs left open circuit default to the high state.
- The logic input requires a current of 3mA to pull it down to the low state.

Connection to the logic input depends on the signal source as follows:

- Solid state or mechanical relay contact: connect between pin 15 (DGND) and logic input pin.
- Pull-down: Connect ground to pin 15 (DGND) and signal to the logic input pin.
- Pull-up: Connect an  $820k\Omega$  resistor from the logic input pin to pin 15 (DGND); this will pull down the input to 2.5V when the pull-up is switched off. Connect ground to pin 15 (DGND) and signal to the logic input pin. If the signal is 24V, then power loss in the resistor across the input can be reduced by adding an  $820k\Omega$  resistor in series with the signal.

### Gauge software configuration

The behaviour of the gauge can be configured via RS232, the optional AiG2 display unit or optional PCIS software. The following three configuration settings need to be adjusted:

1. Configure both light barrier logic input functions to "Length hold" mode.
2. Configure both light barrier logic input active states to **active** when the light barriers are **clear (no object)**:

LB1, LB2 output when clear (no object)	"Length hold" logic input active state
Low (pull down)	Active low
High (pull up)	Active high

3. Configure reset logic input function to "Reset length" mode.
4. Configure reset logic input active state to active high or active low as required.
5. Configure "Length offset" to distance "L" between LB1 and LB2.

**SL / SLR gauge configuration using the optional AiG2 display unit:**

- Navigate to the "Interface" menu and then navigate to the following submenus:

**Logic input function:**

Select "Length hold" for each light barrier logic input.  
 Select "Reset length" for the reset pulse logic input.

**Logic input active state:**

Select "Active high" or "Active low" for each logic input.

- Navigate to the "Measurement" menu and then navigate to the following submenu:

**Length offset:**

Set a positive value corresponding to distance "L".

**Note:** If the default resolution of 1=0.1 m (or ft or yds or inch) of the "Length Offset" parameter is too large, then an enhanced resolution "Length Offset" of 1=0.001 m (or ft or yds or inch) can be factory-enabled in the SL / SLR gauge.

**SL / SLR gauge configuration via RS232:**

The following input parameters can be programmed via RS232 (and other optionally installed interfaces) on the SL / SLR gauge. For further information regarding the data format for programming parameters, please consult the SL / SLR gauge instruction manual.

DW	Data bit	Comments	Value
12	0	Logic input 1 function	1= Length hold 4= Reset length [if signal held for 5s, resets reel number]
	1		
	2		
	3	Logic input 1 polarity	0 = active low (pulled down) 1 = active high (pulled up)
	4	Logic input 2 function	1 = Length hold 4= Reset length [if signal held for 5s, resets reel number]
	5		
	6		
	7	Logic input 2 polarity	0 = active low (pulled down) 1 = active high (pulled up)
	8	Logic input 3 function	1 = Length hold 4= Reset length [if signal held for 5s, resets reel number]
	9		
	10		
11	Logic input 3 polarity	0 = active low (pulled down) 1 = active high (pulled up)	

DW	Comments	Unit	Range	Value
14	Length offset	1=0.1m{ft}{yds}{inch}	3000.0~3000.0m{ft}{yds}{inch}	Set to distance "L"



**Note:** If the default resolution of  $1=0.1 \text{ m}\{\text{ft}\}\{\text{yds}\}\{\text{inch}\}$  of the “Length Offset” (DW14) parameter is too large, then an enhanced resolution “Length Offset” of  $1=0.001 \text{ m}\{\text{ft}\}\{\text{yds}\}\{\text{inch}\}$  can be factory-enabled in the SL / SLR gauge.

## EXAMPLE IMPLEMENTATION USING BANNER QS18 LASER EMITTERS AND QS186LE NPN SENSORS

### DB25 INTERFACE Socket Connection

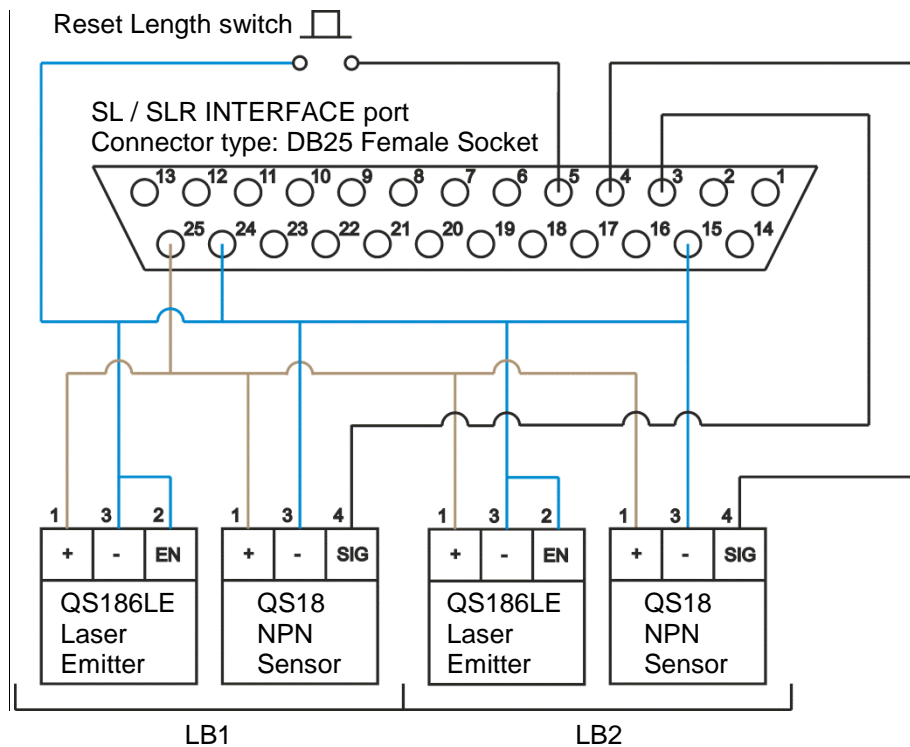

QS186LE Laser Emitter / QS18 NPN Sensor wiring colour code				
Pin	1	2	3	4
Colour	Brown	White	Blue	Black

When no object is present, laser light from the QS186LE laser emitter illuminates the QS18 NPN sensor and its SIG output is pulled low; hence the SL / SLR gauge “Length hold” function must be set to “active low”.

### SL / SLR gauge configuration using the optional AiG2 display unit:

- Navigate to the “**Interface**” menu and then navigate to the following submenus:

#### Logic input function:

Select “Length hold” for logic inputs 1 and 2.  
Select “Reset length” for logic input 3.

#### Logic input active state:

Select “Active low” for logic inputs 1, 2 and 3.

- Navigate to the “**Measurement**” menu and then navigate to the following submenu:

#### Length offset:

Set a positive value corresponding to distance “L”.

### SL / SLR gauge configuration via RS232:

The following input parameters can be programmed via RS232 (and other optionally installed interfaces) on the SL / SLR gauge. For further information regarding the data format for programming parameters, please consult the SL / SLR gauge instruction manual.

DW	Data bit	Comments	Value
12	0	Logic input 1 function	1= Length hold
	1		
	2		
	3	Logic input 1 polarity	0 = active low (pulled down)
	4	Logic input 2 function	1 = Length hold
	5		
	6		
	7	Logic input 2 polarity	0 = active low (pulled down)
	8	Logic input 3 function	4= Reset length [if signal held for 5s, resets reel number]
	9		
	10		
11	Logic input 3 polarity	0 = active low (pull-down)	

DW	Comments	Unit	Range	Value
14	Length offset	1=0.1m{ft}{yds}{inch}	3000.0~3000.0m{ft}{yds}{inch}	Set to distance "L"

### SL mini / SLR mini configuration

#### Configuration via the PCiS\_SLmini software:

- 1 Click the "Interface" button on the main page:

The screenshot displays the 'PC SOFTWARE FOR SL/SLR mini GAUGE' interface. It features a central panel with a 'CAUTION' warning and a 'Trend Graph' showing 'Average Speed' over time. On the left, there are input fields for 'Average Speed' (0.00 m/min), 'Instant Speed' (0.00 m/min), 'Length' (0.0 m), and 'Total Length' (0.0 m). Below these are 'Preset Length 1' and 'Preset Length 2' fields. At the bottom, there are buttons for 'Measurement', 'Interface', 'Circuit', 'Comms', and 'Start Logging'. A status bar at the bottom shows 'RS232 communication failure' and 'GAUGE OK'.

2 | When prompted, enter 64000 for the password and click the “OK” button:

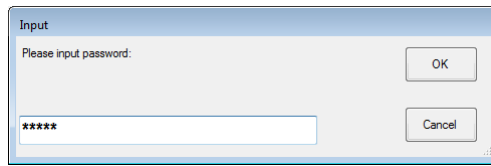

3 | Configure the logic input interfaces as follows and then click the “Exit” button:

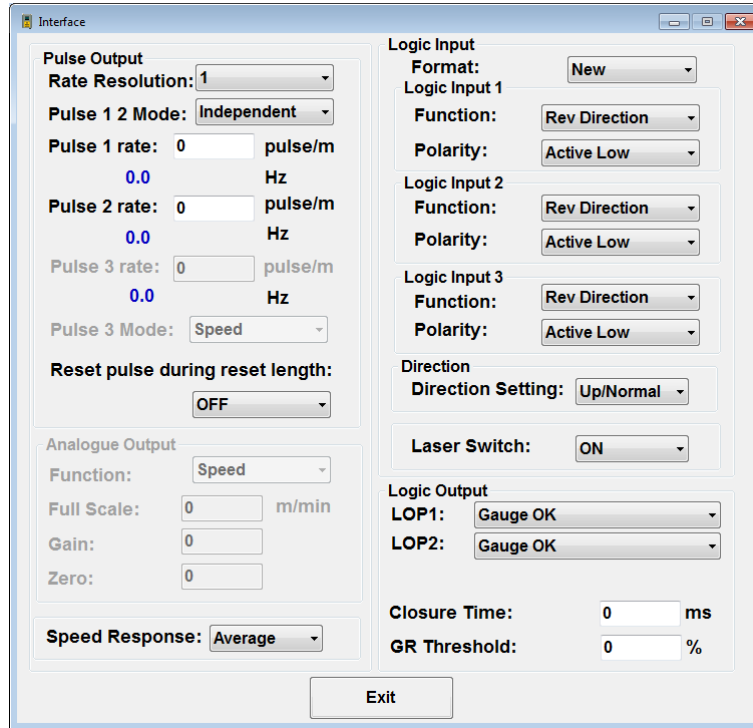

Label	Value	Description	Input DW
Format	New		12.15
<b>Logic Input 1</b>			
Function	Length Hold		12
Polarity	Active Low		12
<b>Logic Input 2</b>			
Function	Length Hold		12
Polarity	Active Low		12
<b>Logic Input 3</b>			
Function	Reset		12
Polarity	Active Low		12

4 Click the “Measurement” button on the main page:

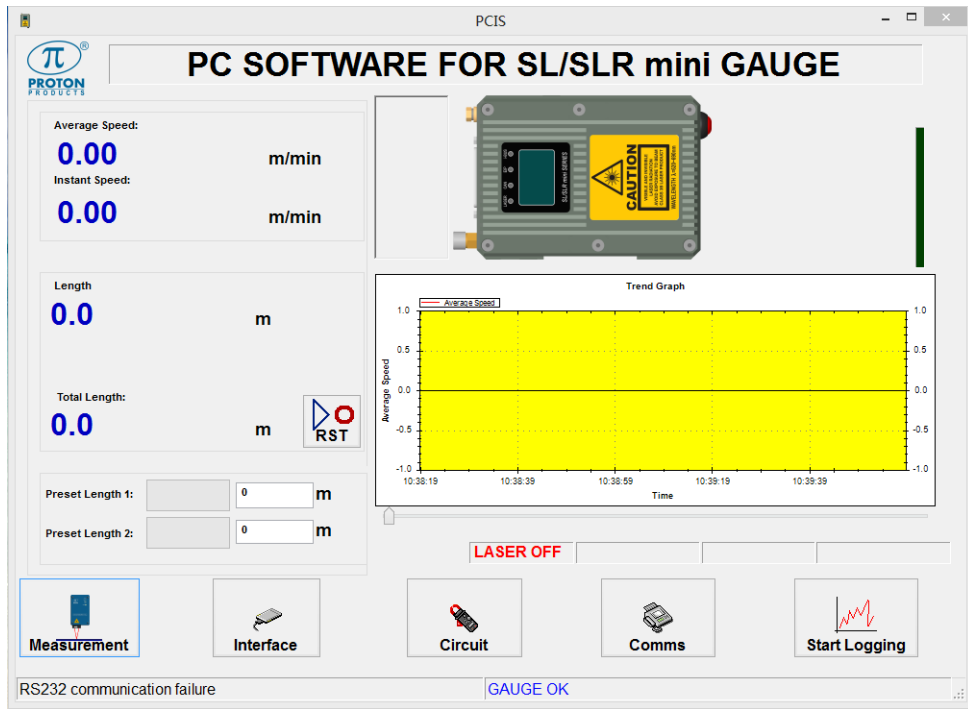

5 When prompted, enter 63000 for the password and click the “OK” button:

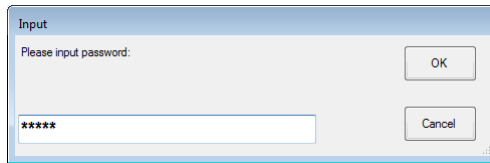

6 Configure the “Length Offset” to the distance between the light barriers and then click the “Exit” button:

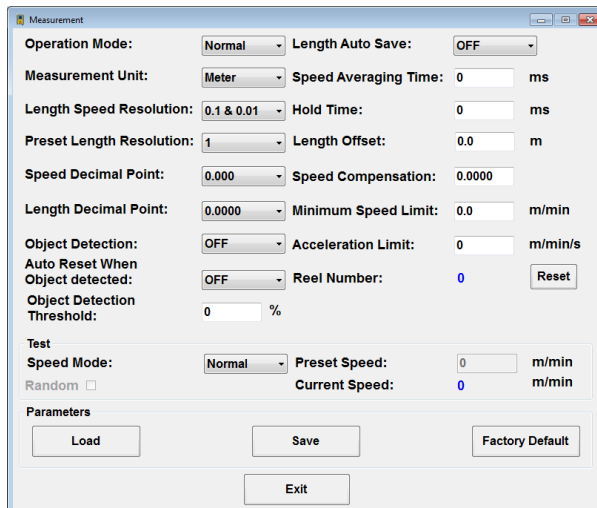

Label	Value*	Description	Input DW
Length Offset	-3000.0 ~ 3000.0 m{ft}{yds}{inch}	Set the required length offset value.	14

**Configuration by input parameters:**

This interface may be configured by writing to the following input parameters:

**Input parameters**

DW	Bit	Comment	Unit	Range/Remark	Default
12		<b>Logic input(new format;DW12.15=1)</b>			
	0				
	1	Logic input 1 function		1=Length hold	0
	2				
	3	Logic input 1 polarity		0=Active low	0
	4				
	5	Logic input 2 function		1=Length hold	1
	6				
	7	Logic input 2 polarity		0=Active low	0
	8				
	9	Logic input 3 function		4=Reset	4
	10				
	11	Logic input 3 polarity		0=Active low	0
	12	Direction setting (available only when no logic input for direction)		0=Count up 1=Count down	0
	13~14	Not used			
15	Must be 1			1=New format logic inputs	

DW	Bit	Comment	Unit	Range/Remark	Default
14		Length offset	1=0.1m{ft}{yds}{inch}	-3000.0~3000.0m{ft}{yds}{inch}	0

This device complies with Part 15 of the FCC Rules. Operation is subject to the following two conditions: (1) this device may not cause harmful interference, and (2) this device must accept any interference received, including interference that may cause undesired operation.

The users manual or instruction manual for an intentional or unintentional radiator shall caution the user that changes or modifications not expressly approved by the party responsible for compliance could void the user's authority to operate the equipment. In cases where the manual is provided only in a form other than paper, such as on a computer disk or over the Internet, the information required by this section may be included in the manual in that alternative form, provided the user can reasonably be expected to have the capability to access information in that form.

This equipment has been tested and found to comply with the limits for a Class A digital device, pursuant to part 15 of the FCC Rules. These limits are designed to provide reasonable protection against harmful interference when the equipment is operated in a commercial environment. This equipment generates, uses, and can radiate radio frequency energy and, if not installed and used in accordance with the instruction manual, may cause harmful interference to radio communications. Operation of this equipment in a residential area is likely to cause harmful interference in which case the user will be required to correct the interference at his own expense.

#### Radiation Exposure Statement

This equipment complies with FCC radiation exposure limits set forth for an uncontrolled environment. This equipment should be installed and operated with minimum distance 20cm between the radiator & your body.

## CONTACT DETAILS FOR ENQUIRIES, SALES AND SERVICE

WEB SITE [www.protonproducts.com](http://www.protonproducts.com)

### ENQUIRIES AND SALES

USA head office:

**Weber and Scher,**  
P.O. Box 366,  
1231 U.S. Highway 22 East,  
Lebanon Borough,  
New Jersey,  
U.S.A.  
Tel: +1 (908) 236 8484  
Fax: +1 (908) 236 7001  
Email: [usa@protonproducts.com](mailto:usa@protonproducts.com)

European head office:

**Proton Products Europe N.V.,**  
Nieuwbaan 81,  
B-1785,  
Merchtem-Peizegem,  
BELGIUM  
Tel: +32 (0) 52 466 311  
Fax: +32 (0) 52 466 313  
Email: [europe@protonproducts.com](mailto:europe@protonproducts.com)

Asia head office:

**Proton Products Chengdu Ltd.,**  
Room 401, Building G3 (TianFu Software  
Park Zone G), No. 1800 Central YiZhou  
Avenue, Chengdu, 610041,  
CHINA  
Tel: +86 (0) 28 8439 3112  
Fax: +86(0) 28 65717677  
Email: [asia@protonproducts.com](mailto:asia@protonproducts.com)

Global head office:

**Proton Products International Ltd.,**  
10 Aylesbury End,  
Beaconsfield,  
Buckinghamshire,  
ENGLAND  
Email: [contact@protonproducts.com](mailto:contact@protonproducts.com)

### SERVICE ENQUIRIES

Please contact your local Proton Products agent for service enquiries (please see [www.protonproducts.com](http://www.protonproducts.com) for agent contact details) or email:

America: [americas.service@protonproducts.com](mailto:americas.service@protonproducts.com)

Asia: [asiapac.service@protonproducts.com](mailto:asiapac.service@protonproducts.com)

Europe: [europe.service@protonproducts.com](mailto:europe.service@protonproducts.com)

### MANUAL FEEDBACK AND COPYRIGHT

Please email feedback on this manual to: [manuals@protonproducts.com](mailto:manuals@protonproducts.com)

- This manual contains details of equipment and software manufactured and supplied by Proton Products.
- Equipment, products and related features made or introduced before or after the issue of this manual may not be included in this manual.
- Specifications and information contained within this publication are subject to change without notice.
- Proton Products is not responsible for any errors or omissions contained within this manual.
- Proton Products is not responsible for consequential or incidental damage related to the provision or use of the information contained in this manual.
- The information contained in this manual is the property of Proton Products and may not be circulated or distributed to third parties.
- This manual may be copied in accordance with the following conditions:  
**Printed manual:** no part of the manual may be reproduced or converted to electronic format (such as by scanning) without the prior express written permission of Proton Products.  
**Manual in electronic format (e.g. CD-ROM):** one electronic copy and one printout may be made for storage and use at the site of product use.