

# ORiNOCO® 802.11n & 802.11ac Access Points

## Hardware Installation Guide

### Products Covered

- ORiNOCO® AP-800
- ORiNOCO® AP-8000
- ORiNOCO® AP-8100
- ORiNOCO® AP-9100

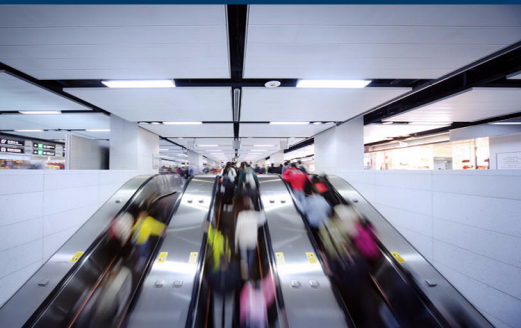

---

## Copyright

© 2015 Proxim Wireless Corporation, Fremont, CA. All rights reserved. Covered by one or more of the following U.S. patents: 5,231,634; 5,875,179; 6,006,090; 5,809,060; 6,075,812; 5,077,753. This guide and the software described herein are copyrighted with all rights reserved. No part of this publication may be reproduced, transmitted, transcribed, stored in a retrieval system, or translated into any language in any form by any means without the written permission of Proxim Wireless Corporation.

## Trademarks

ORiNOCO® and the Proxim logo are the trademarks of Proxim Wireless Corporation. All other trademarks mentioned herein are the property of their respective owners.

## Disclaimer

Proxim reserves the right to revise this publication and to make changes in the content from time-to-time without obligation on the part of Proxim to provide notification of such revision or change. Proxim may make improvements or changes in the product(s) described in this guide at any time. When using these devices, basic safety precautions should always be followed to reduce the risk of fire, electric shock and injury to persons.

**ORiNOCO® 802.11n & 802.11ac Access Points - Hardware Installation Guide**

Documentation Version: 4.3  
P/N 765-00154, June 2015

<b>Preface</b> .....	<b>5</b>
<b>1 Introduction</b> .....	<b>7</b>
About ORiNOCO® 802.11n & 802.11ac Access Points .....	7
Salient Features .....	7
Multiple-Input-Multiple-Output .....	8
<b>2 Hardware Overview and Installation</b> .....	<b>9</b>
Device Operational Modes .....	9
ORiNOCO® AP-800 and AP-8000 .....	10
Hardware Overview .....	10
LED Indicators .....	10
Antennas .....	10
Power Socket .....	11
Reset .....	11
Reload .....	11
Ethernet Port .....	11
Serial Port .....	11
System Requirements .....	12
Product Package .....	12
Optional Accessories .....	13
Installation Procedure .....	13
Step 1: Install the Antennas .....	13
Step 2: Mount the Device .....	13
Step 3: Plugging in the Cables .....	15
Step 4: Power On the Device .....	15
Step 5: View LEDs .....	15
Step 6: Install Cable Security Cover (Optional) .....	16
ORiNOCO® AP-8100 .....	16
Front View of the Device .....	16
LED Indicators .....	16
Reload .....	17
Rear View of the Device .....	17
Ethernet Port .....	17
Power Socket .....	17
Keyhole .....	17
Kensington Lock .....	17
Cable Route .....	18
Vent-Holes .....	18
System Requirements .....	18
Product Package .....	18
Optional Accessories .....	19

Installation Procedure . . . . .	19
Step 1: Plugging in the Cables . . . . .	19
Step 2: Mount the Device . . . . .	20
Step 3: Power On the Device . . . . .	22
Step 4: View LEDs . . . . .	22
ORiNOCO® AP-9100 . . . . .	23
Front View of the Device . . . . .	23
LED Indicators . . . . .	23
Reload . . . . .	23
Rear View of the Device . . . . .	24
Ethernet Port . . . . .	24
Power Socket . . . . .	24
Keyhole . . . . .	24
Kensington Lock . . . . .	24
Cable Route . . . . .	24
Vent-Holes . . . . .	24
System Requirements . . . . .	24
Product Package . . . . .	25
Optional Accessories . . . . .	26
Installation Procedure . . . . .	26
Step 1: Plugging in the Cables . . . . .	26
Step 2: Mount the Device . . . . .	26
Step 3: Power On the Device . . . . .	28
Step 4: View LEDs . . . . .	29
<b>3 Hardware Specifications . . . . .</b>	<b>30</b>
ORiNOCO® AP-800 and AP-8000 . . . . .	31
Antenna Specifications . . . . .	33
Omni Directional Antenna Specifications . . . . .	33
Range Extender Antenna (REA) Specifications . . . . .	34
ORiNOCO® AP-8100 . . . . .	37
Antenna Specifications . . . . .	39
ORiNOCO® AP-9100 . . . . .	41
Antenna Specifications . . . . .	43
IEEE Spectral Mask Specifications: . . . . .	45
<b>A Glossary and Abbreviations . . . . .</b>	<b>46</b>
<b>B Statement of Warranty . . . . .</b>	<b>50</b>
<b>C Technical Services and Support . . . . .</b>	<b>52</b>
<b>D FCC Safety &amp; Regulatory Information . . . . .</b>	<b>56</b>

# Preface

This chapter contains information on the following:

- [About this Guide](#)
- [Products Covered](#)
- [Audience](#)
- [Prerequisites](#)
- [Documentation Conventions](#)
- [Related Documents](#)

## About this Guide

This guide gives a jump start working knowledge on the ORiNOCO® 802.11n & 802.11ac Access Points and details on their hardware specifications and installation procedures.

## Products Covered

Listed below are the products covered in this guide:

Product(s)	Supported SKUs
ORiNOCO® AP-800	US, WD, JP
ORiNOCO® AP-8000	US, WD, JP
ORiNOCO® AP-8100	US, WD, JP, EU
ORiNOCO® AP-9100	US, WD, JP, EU

## Audience

The intended audience for this guide are the network administrators who installs and/or manages the device.

## Prerequisites



The reader of this guide should have working knowledge of Wireless Networks, Local Area Networking (LAN) concepts, Network Access Infrastructures and Client-Server Applications.

## Documentation Conventions

### Icon Representation

Name	Image	Description
Note		A special instruction that draws attention of the user.

---

Important		A note of significant importance that a user should be aware of.
Caution		A warning that cautions the user of a possible danger.

### Related Documents

For more information, please refer to the following additional documents that are available at Proxim’s support site <http://support.proxim.com>.

- **Quick Installation Guide (QIG)** - A quick reference guide that provides essential information to install and configure the device.
- **Software Management Guide** - A guide that provides instructions on how to configure, manage and monitor the device by using Web Interface.
- **Reference Guide** - A guide that provides instructions on how to configure, manage and monitor the device by using Command Line Interface.
- **Safety and Regulatory Compliance Guide** - A guide that provides country specific safety and regulatory norms to be followed while installing the devices.

: For regulatory information and latest product updates, visit our support site <http://support.proxim.com>.





## Introduction

This chapter contains information on the following:

- [About ORiNOCO® 802.11n & 802.11ac Access Points](#)
- [Salient Features](#)
- [Multiple-Input-Multiple-Output](#)

### 1.1 About ORiNOCO® 802.11n & 802.11ac Access Points

Proxim's ORiNOCO® 802.11n & 802.11ac Access Point family comprises the following products, that are designed to deliver flexible, scalable and reliable Data, Voice, and Video for small and medium Enterprise WLAN deployments.

Product(s)	Description	Image
ORiNOCO® AP-800	An indoor 802.11n Access Point with dual-band, 3x3 MIMO (Multiple Input and Multiple Output) single radio which operates either in 2.4 or 5 GHz. This connectorized unit comes with 3 omni-directional antennas.	
ORiNOCO® AP-8000	An indoor 802.11n Access Point with dual-band, 3x3 MIMO (Multiple Input and Multiple Output) dual-radio, where one operates in 5GHz and other in 2.4GHz. This connectorized unit comes with 6 omni-directional antennas, 3 per radio.	
ORiNOCO® AP-8100	An indoor 802.11n Access Point with 2x2 MIMO (Multiple Input and Multiple Output) dual-radio, where one operates in 5GHz and other in 2.4GHz. This unit comes with 4 integrated antennas, 2 per radio.	
ORiNOCO® AP-9100	Proxim's ORiNOCO® AP-9100 is an indoor 802.11ac + 802.11b/g/n dual radio Access Point with dual-band (5 & 2.4 GHz) and 3x3 MIMO (Multiple Input and Multiple Output). This integrated unit comes with built-in 6 omni-directional antennas, 3 per radio.	

### 1.2 Salient Features

#### AP-800/ AP-8000/ AP-8100/ AP-9100

- Easy operation and installation
- Provides wall mounting or ceiling option for flexible device installation.
- Distributed WLANs with Centralized Management.
- Management through a Web Interface (HTTP), Command Line Interface (CLI), Simple Network Management Protocol (SNMP) and ProximVision Network Management System (PVNMS)
- Advanced 802.11i support for enterprise-grade security

**AP-800/ AP-8000/ AP-8100**

- Industry-leading throughput in 802.11b/g/n and 802.11a/n modes in the 2.4 GHz and 5 GHz respectively.
- Highest throughput with single radio rates of 300 Mbps and dual radio rates of 600 Mbps.
- Tested against Wi-Fi Alliance interoperability test suite and certified as interoperable with Wi-Fi client access product.

**AP-9100**

- Industry-leading throughput in 802.11b/g/n and 802.11ac modes in the 2.4 GHz and 5 GHz respectively.
- Highest throughput with the radio rates of 1300 Mbps for 802.11ac Radio and 450 Mbps for 802.11n Radio.

## 1.3 Multiple-Input-Multiple-Output

ORiNOCO® Access Point devices support Multiple-Input-Multiple-Output (MIMO) antenna technology that uses multiple antennas at both the transmitting end and receiving end to improve communication performance. The underlying technology of these access point radio(s) are based on a combination of MIMO and OFDM (Orthogonal Frequency Division Multiplexing). MIMO-OFDM combination radios solve interference, fading and multipath problems. Having multiple receivers at the receiving end, increases the amount of received power and also reduces multipath problems by combining the received signals for each frequency component separately. Hence, MIMO significantly improves the overall gain.

MIMO also uses Spatial multiplexing transmission technique to transmit independent and separately encoded data signals from each of the multiple transmit antennas while reusing or multiplexing in the space dimension. These independent data signals are called Spatial streams. The transmitting end of the device uses multiple radio Tx chains and signal paths to simultaneously transmit different data streams, whereas the receiving end combines the Rx signals resulting in higher throughput.

By increasing the number of receiving and transmitting antennas, the throughput of the channel increases linearly resulting in high spectral efficiency.



## Hardware Overview and Installation

This chapter covers the hardware overview and installation procedures of the following products:

- [ORiNOCO® AP-800 and AP-8000](#)
  - [Hardware Overview](#)
  - [System Requirements](#)
  - [Product Package](#)
  - [Installation Procedure](#)
- [ORiNOCO® AP-8100](#)
  - [Front View of the Device](#)
  - [Rear View of the Device](#)
  - [System Requirements](#)
  - [Product Package](#)
  - [Installation Procedure](#)
- [ORiNOCO® AP-9100](#)
  - [Front View of the Device](#)
  - [Rear View of the Device](#)
  - [System Requirements](#)
  - [Product Package](#)
  - [Installation Procedure](#)



:

- **All the interface (radio) 2 parameters discussed in this chapter are applicable only to a dual-radio device.**
- **For a quick reference on how to install and mount the device, please refer to the [ORiNOCO® AP-800, AP-8000, AP-8100 and AP-9100 Quick Installation Guides](#) respectively.**

### 2.1 Device Operational Modes

Device Type	Operational Mode (With Supported Frequency Band)	
	Radio 1	Radio 2
<b>AP-800</b>	802.11b/g/n (2.4 GHz)	Not Applicable
<b>AP-8000</b>	802.11a/n (5 GHz)	802.11b/g/n (2.4 GHz)
<b>AP-8100</b>	802.11a/n (5 GHz)	802.11b/g/n (2.4 GHz)
<b>AP-9100</b>	802.11a/n/ac (5 GHz)	802.11b/g/n (2.4 GHz)



: The operational mode 'g/n' is backward compatible to mode 'b'.

## 2.2 ORiNOCO® AP-800 and AP-8000

### 2.2.1 Hardware Overview

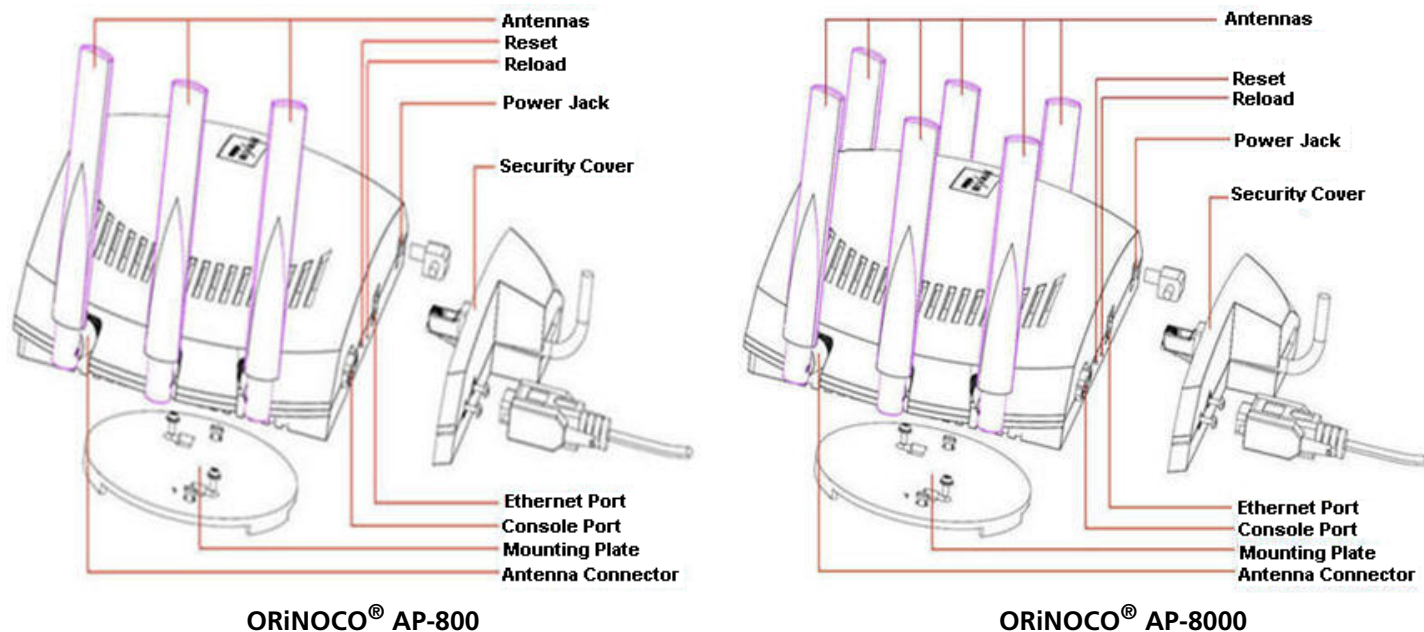

Figure 2-1 Device Overview

Following sections give you hardware overview of AP-800 and AP-8000.

#### 2.2.1.1 LED Indicators

Tabulated below are the four LEDs, that are available on the top panel of the device:

LED	Symbol	Description
Power LED		This LED indicates whether the device is switched on/off.
Ethernet LED		This LED signals the traffic on the wired ethernet LAN.
WirelessInterface (Radio) 1 LED		This LED provides the status of the traffic on wireless interface (radio) 1. Refer <a href="#">Device Operational Modes</a> .
WirelessInterface (Radio) 2 LED		This LED provides the status of the traffic on wireless interface (radio) 2. Refer <a href="#">Device Operational Modes</a> .

#### 2.2.1.2 Antennas

The AP device comes with 3x3 MIMO omni-directional antennas that are easy to install. Proxim also recommends you an optional accessory - **Range Extender Antenna (REA)** with a 3 x RP SMA plug, that can be easily connected to the device. See [Installation Procedure](#), for details on installation of antennas.

- AP-800 comes with three omni directional antennas.
- AP-8000 comes with six omni directional antennas, three per radio.

## Antenna Ports

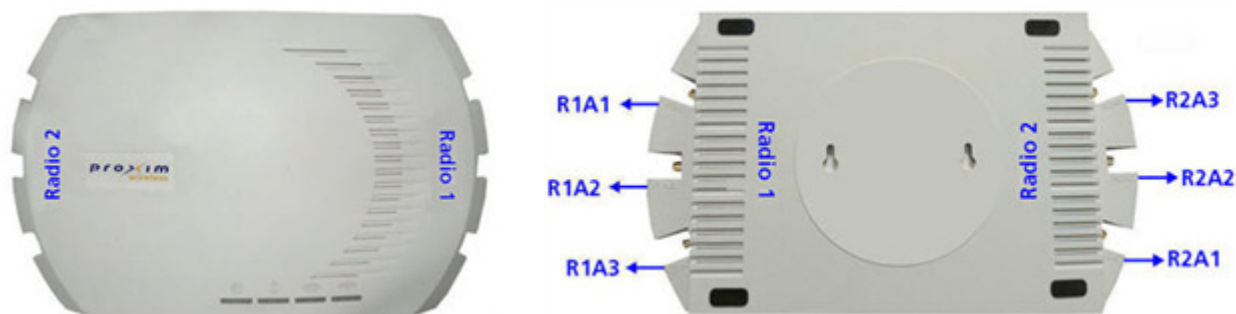

**Top View of the Device**

**Bottom View of the Device**

If you hold the AP device in its upright position, such that the LEDs on the top panel of the device are towards your right hand side and the 'Proxim' logo towards your left, then:

- Radio 1 and its corresponding antenna ports (R1A1, R1A2 and R1A3), are present on the right hand side of the device.
- Radio 2 and its corresponding antenna ports (R2A1, R2A2 and R2A3), are present on the left hand side of the device.

### 2.2.1.3 Power Socket

This socket connects to the 5 VDC power adapter.

### 2.2.1.4 Reset

Reset button enables a user to powercycle the device.

### 2.2.1.5 Reload

Reload feature helps to restore the device to factory default configuration, when:

- The device cannot be accessed through web interface or command line interface.
- The device does not initialize.
- The password is lost.

For more details, see *Recovery Procedures* and *Forced Reload* procedures, detailed in the *ORiNOCO® 802.11n Access Points - Software Management Guide*.

### 2.2.1.6 Ethernet Port

The Ethernet Port of the device allows the user to connect to the LAN by using CAT5e / CAT6 ethernet cable.

### 2.2.1.7 Serial Port

The device has RS-232 connector by using which serial communication can be established, for debugging and management.

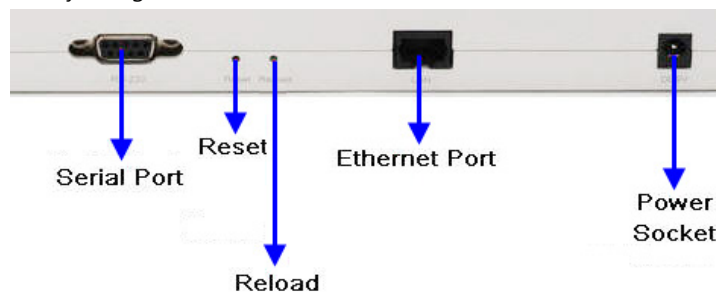

**Figure 2-2 Rear View of the Device**





### 2.2.2 System Requirements

Following are the minimum system requirements to use the device:

1. Any 802.11 compliant wireless adapter.
2. A computer that is connected to the same IP network as the AP and has one of the following installed:
  - Web Browser
  - Telnet
  - RS-232 Serial Port
  - MIB Browser
  - Ethernet NIC Card
3. Ethernet switch, cross-over or straight Ethernet cable.
4. A 5V DC Power Adapter or a Power over Ethernet (PoE) Adapter

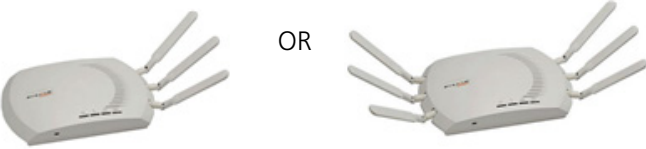

### 2.2.3 Product Package

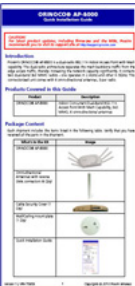
Each shipment includes the items listed in the following table. Please verify that you have received all the parts in the shipment, prior to the installation.

What's in the Kit	Image
ORiNOCO® AP-800 or AP-8000	
Omni-directional Antennas with reverse SMA connectors. <ul style="list-style-type: none"> <li>• AP-800: Quantity - 3</li> <li>• AP-8000: Quantity - 6</li> </ul>	
Cable Security Cover	
Mounting Kit	
Quick Installation Guide (QIG)	

### 2.2.3.1 Optional Accessories

Tabulated below are the recommended optional accessories, that are supplied on request from Proxim Wireless Corporation.

Accessory	Image
110-220V worldwide Power Adapter	
Range Extender Antenna (REA)	
Gigabit Ethernet PoE	

## 2.2.4 Installation Procedure

Perform the following steps to install and mount the device.

### 2.2.4.1 Step 1: Install the Antennas

The omni-directional antennas supplied with the product do not require any professional installation. Only, the regular outdoor antennas connected via a pigtail conversion cable, offering a standard connector type for antenna connection, require a professional installation.



*Optionally, you can use the Range Extended Antenna (REA), which has 3 x RP SMA plug, that can be easily connected to the device.*

Perform the following steps to assemble the antennas:

1. Hand-tighten the antennas clockwise, onto the external connectors of the device until they are attached firmly.
2. Position the antennas close to the horizontal surface (ceiling or wall), so as to get the maximum signal coverage of the omni-directional antenna.

### 2.2.4.2 Step 2: Mount the Device

Consider the following precautions, before mounting the device:

- The device must be protected from exposure, and the environmental conditions must be within those specified in the product datasheet, that can be found at <http://support.proxim.com>.
- Ensure to use a +5V/3.5 A power adapter, to power on the device.



- *Note that the device is build with fire retardant ATX200 resin and can be installed in the plenum. In an office building, plenum is the space between the structural ceiling and the tile ceiling that is provided to help air circulate. Many companies also use the plenum to house communication equipment and cables. These products and cables must comply with certain safety requirements, such as Underwriter Labs (UL) and Standard 2043: "Standards for Fire Test for Heat and Visible Smoke Release for Direct Products and Their Accessories installed in Air-Handling Spaces".*
- *When installed in a plenum, the device must use PoE.*

Conduct a site survey to determine the best location for the device. You can either mount the device to a wall or mount it to the T-bar ceiling, as follows:

### Wall-Mounting:

To mount the device to a wall, follow the following steps:

1. If the device is powered on, unplug all the power cables.
2. Place the mounting plate on the wall with the embossed inverted letter "L" facing your right, as shown below:

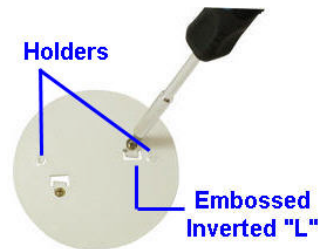

**Figure 2-3 Mounting Plate**

3. Fasten the mounting plate by using a pair of plastic anchors and screws provided with the product package.
4. Hold the device with its rear panel facing up. Next, align two keyholes on the device with the two holders on the mounting plate.
5. Carefully slide the device down until the holders on the mounting plate fasten securely onto the keyholes of the device.



**Figure 2-4 Mount the Device**

### Ceiling Mounting:

To mount the device to ceiling, follow the following steps:

1. If the device is powered on, unplug all the power cables.
2. Place the mounting plate onto the ceiling with the embossed inverted letter "L" facing your right. Refer [Mounting Plate](#)
3. Fasten the mounting plate by using a pair of plastic anchors and screws provided with the product package.
4. Hold the device with its rear panel facing front. Next, align two keyholes on the device with the two holders on the mounting plate.
5. Carefully slide the device towards rear side until the holders on the mounting plate fasten securely onto the keyholes of the device.

### 2.2.4.3 Step 3: Plugging in the Cables

#### Cabling with Power Adapter (Not supplied with the product package)

To plug in the cables by using a 5V DC power adapter:

- Connect one end of the CAT5e/CAT6 Ethernet cable (not supplied with the product) to the device's ethernet port and the other end to a PC.
- Plug the barrel of the power cable into the device's power socket, only after the device installation is complete.

#### Cabling with Gigabit PoE (Not supplied with the product package)

To use Power over Ethernet (PoE), we recommend you to use our Gigabit Ethernet PoE adapter ORiNOCO 1-Port Active Ethernet DC Injector (See [Optional Accessories](#)) and follow the following guidelines:

- Connect one end of the ethernet cable to the **Data In** port of the DC Injector and the other end to a PC.
- Connect one end of the second ethernet cable (not supplied with the product) to the device's ethernet port, and the other end to the **Data & Power Out** Port of the DC Injector, only after the device installation is complete.



: PoE should be installed only in an indoor network, maintaining a controlled temperature.

#### Serial Connection

Optionally, you can connect a nine-pin, male-to-female serial cable to the console port/DB9 connector of the device for debugging and management.



- Use a straight-through ethernet cable, if you intend to connect the device to a switch, hub, or patch panel.
- Use a cross-over ethernet cable or adapter if you intend to connect the device to a single computer.
- The pin6 on RJ11 connector is used for power consumption and debugging. This connects internally to the 12VDC.
- If power is drawn from this input pin, then the radio might malfunction.



### 2.2.4.4 Step 4: Power On the Device

To power on the device, plug in the power cord into a power outlet. There is no ON/OFF switch on the device. To disconnect power:

- Unplug the RJ45 connector from the **Data & Power Out** port on the DC injector, if using the Gigabit Ethernet PoE.
- Unplug the power cable from the power socket of the device, if using power adapter.

### 2.2.4.5 Step 5: View LEDs

When the device is powered on, it performs startup diagnostics. When startup is complete, the LEDs show the operational state of the device. Tabulated below is the behavior of the four LEDs on the device:

LED	Behavior	Color
<b>Power LED</b>	Glows green when the device is switched ON.	
<b>Ethernet LED</b>	Glows red when the ethernet interface is connected to a 100 Mbps link.	
	Glows green when the ethernet interface is connected to a 1000 Mbps link.	

<b>Wireless Interface (Radio) 1 LED</b>	<ul style="list-style-type: none"> <li>The Wireless LEDs glow steady green in operational status.</li> <li>Blinks green, if wireless traffic is being transmitted or received.</li> </ul>	
<b>Wireless Interface (Radio) 2 LED</b>		

: The LEDs glow 'orange' when the device initializes.

### 2.2.4.6 Step 6: Install Cable Security Cover (Optional)

When the RS-232 cable is not connected, we recommend you to install a cable security cover to prevent the power socket, LAN ports, reset and reload buttons from getting tampered. Follow the following procedure to install the cable security cover:

1. Open the split end of the security cover just enough to slide the power cable (if the Gigabit Ethernet PoE is not used) and the CAT6 ethernet cable through the opening until they fit inside the straight clamping portion of the cover.
2. Exercise care, as you slide the cable(s) so that you do not accidentally break the cover.
3. Slide the hinging end of the security cover and insert the latch into the hole at the rear end of the device.
4. Insert the two screws into the screw holes near serial port and fasten the security cover on the device.

## 2.3 ORiNOCO® AP-8100

### 2.3.1 Front View of the Device

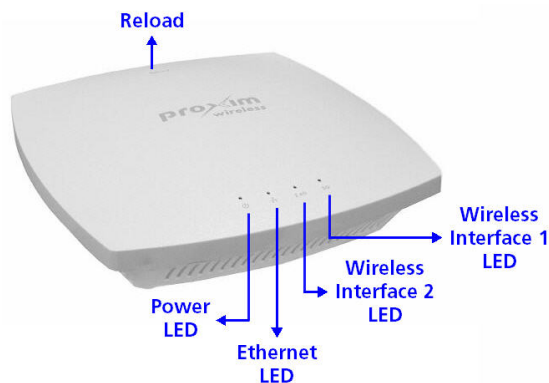



Figure 2-5 Front View of the AP-8100

The front panel of the device contains the following components:

#### 2.3.1.1 LED Indicators

Tabulated below are the four LEDs, that are available on the front panel of the device:

LED	Symbol	Description
Power LED		This LED indicates whether the device is switched ON/OFF.
Ethernet LED		This LED indicates the status of the traffic over the wired ethernet LAN.



2.4G (Wireless Interface 2) LED	2.4G	This LED indicates the status of the traffic over the wireless interface (radio) 2. Refer <a href="#">Device Operational Modes</a> .
5G (Wireless Interface 1) LED	5G	This LED indicates the status of the traffic over the wireless interface (radio) 1. Refer <a href="#">Device Operational Modes</a> .

### 2.3.1.2 Reload

Reload button helps to restore the device to factory default configuration, when:

- The device cannot be accessed through web interface or command line interface.
- The device does not initialize.
- The password is lost.

To avoid tampering, you can lock the reload button on the device and disable the reload functionality. For more details, refer to the *Reload* feature and *Recovery Procedures* illustrated in *ORiNOCO® 802.11n Access Points - Software Management Guide*.

## 2.3.2 Rear View of the Device

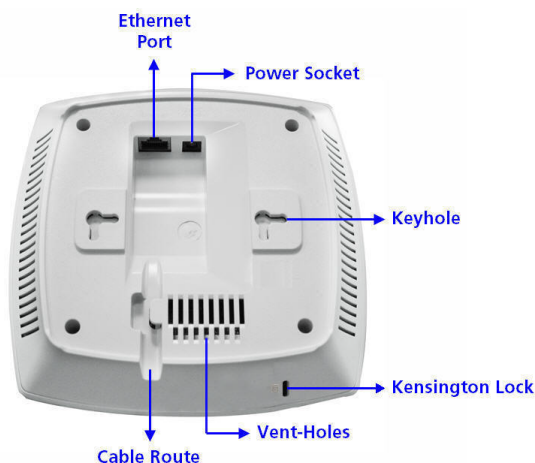

Figure 2-6 Rear View of the Device

The rear panel of the device contains the following components:

### 2.3.2.1 Ethernet Port

The Ethernet port of the device allows the user to connect to the LAN by using CAT5e / CAT6 ethernet cable.

### 2.3.2.2 Power Socket

This socket connects to the 12 VDC power adapter.

### 2.3.2.3 Keyhole

A provision to fix the device onto the mounting plate.

### 2.3.2.4 Kensington Lock

A security slot to lock the device.

**2.3.2.5 Cable Route**

A slot for the CAT5e / CAT6 ethernet cable and the power cable to rest securely.

**2.3.2.6 Vent-Holes**

Ventilation holes on the device allow heat dissipation.



**2.3.3 System Requirements**

Following are the minimum system requirements to use the device:

1. Any 802.11 compliant wireless adapter.
2. A computer that is connected to the same IP network as the AP and has one of the following installed:
  - Web Browser
  - Telnet
  - MIB Browser
  - Ethernet NIC Card
3. Ethernet switch, cross-over or straight Ethernet cable.
4. A 12V DC Power Adapter or a Power over Ethernet (PoE) Adapter.

**2.3.4 Product Package**

Each shipment includes the items listed in the following table. Please verify that you have received all the parts in the shipment, prior to the installation.

What's in the Kit	Image										
ORiNOCO® AP-8100											
Power adapter with Country specific Power Plug(s) <table border="1" data-bbox="324 1486 594 1619"> <thead> <tr> <th>SKU</th> <th>Power Plug(s)</th> </tr> </thead> <tbody> <tr> <td>WD</td> <td>US, UK, EU</td> </tr> <tr> <td>US</td> <td>US</td> </tr> <tr> <td>JP</td> <td>US</td> </tr> <tr> <td>EU</td> <td>UK, EU</td> </tr> </tbody> </table>	SKU	Power Plug(s)	WD	US, UK, EU	US	US	JP	US	EU	UK, EU	
SKU	Power Plug(s)										
WD	US, UK, EU										
US	US										
JP	US										
EU	UK, EU										
Mounting Kit											

What's in the Kit	Image
Quick Installation Guide (QIG)	

**2.3.4.1 Optional Accessories**

Tabulated below are the recommended optional accessories, that are supplied on request from Proxim Wireless Corporation.

Accessory	Part Number	Image	Description
PoE Adapter (US/CAN/JP Power Cord)	76282		PoE module helps you to power ON the device via ethernet cabling.
PoE Adapter (EU Power Cord)	76288		
PoE Adapter (UK Power Cord)	76287		

**2.3.5 Installation Procedure**

Perform the following steps to mount and install the device.

**2.3.5.1 Step 1: Plugging in the Cables**

**Cabling with Power Adapter (Supplied with the product package)**

To plug in the cables by using a 12V DC power adapter:

- Connect one end of the CAT5E/CAT6 Ethernet cable to the device’s ethernet port and the other end to a PC.
- Plug the barrel of the power cable into the device’s power socket, only after the device installation is complete.



: Use a cable-tie to ensure that the power cable stays intact with the device power socket.

**Cabling with Gigabit PoE (Not supplied with the product package)**

To use Power over Ethernet (PoE), we recommend you to use our Gigabit Ethernet PoE adapter ORiNOCO 1-Port Active Ethernet DC Injector (See [Optional Accessories](#)) and follow the following guidelines:

- Connect one end of the ethernet cable to the **Data In** port of the DC Injector and the other end to a PC.
- Connect one end of the second ethernet cable to the device’s ethernet port, and the other end to the **Data & Power Out** Port of the DC Injector, only after the device installation is complete.



: PoE should be installed only in an indoor network, maintaining a controlled temperature.

### 2.3.5.2 Step 2: Mount the Device

Consider the following precautions, before mounting the device:

- The device must be protected from exposure, and the environmental conditions must be within those specified in the product datasheet that can be found at <http://support.proxim.com>.
- Ensure to use a +12V/1.25 A power adapter, to power on the device.
- Ensure that there is no power supply, until the device installation is complete.



- *Note that the device is build with fire retardant ATX200 resin and can be installed in the plenum. In an office building, plenum is the space between the structural ceiling and the tile ceiling that is provided to help air circulate. Many companies also use the plenum to house communication equipment and cables. These products and cables must comply with certain safety requirements, such as Underwriter Labs (UL) and Standard 2043: "Standards for Fire Test for Heat and Visible Smoke Release for Direct Products and Their Accessories installed in Air-Handling Spaces".*
- *When installed in a plenum, the device must use PoE.*

Conduct a site survey to determine the best location for the device. You can either mount the device to a wall or mount it to the T-bar ceiling, as follows:

#### Wall-Mounting:

To mount the device to a wall:

1. Place the mounting plate on the wall such that the embossed letter 'L' is at the top-center position and the vent-holes are facing your left hand side.

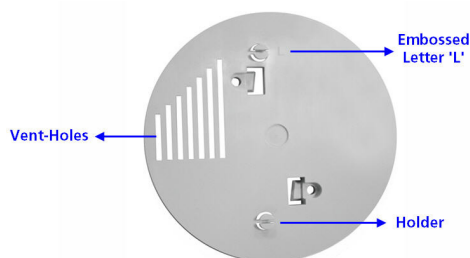
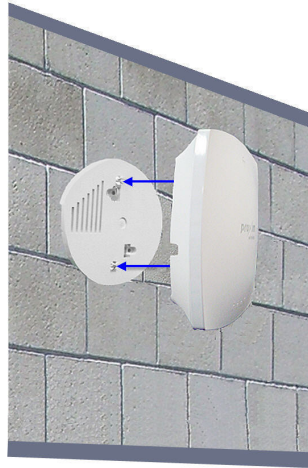

Figure 2-7 Mounting Plate

2. Fasten the mounting plate by using a pair of plastic anchors and screws provided with the product package.
3. Hold the device in the upright position (with 'Reload' on top and the 'LEDs' at the bottom), such that the vent-holes on the device and the vent-holes on the mounting plate rest on each other.
4. Align the two keyholes on the device with the two holders on the mounting plate.
5. Carefully, slide the device towards your right hand side, until the holders on the mounting plate fasten securely onto the keyholes of the device.



**Figure 2-8 Wall Mounting**

### **Ceiling Mounting:**

1. Place the mounting plate on the T-bar ceiling such that the embossed letter 'L' is at the top-center position and the vent-holes are facing your left hand side.
2. Fasten the mounting plate by using a pair of plastic anchors and screws provided with the product package.
3. Hold the device with its rear panel facing the mounting plate, such that the vent-holes on the device and the vent-holes on the mounting plate rest on each other.
4. Align the two keyholes on the device with the two holders on the mounting plate.
5. Carefully, slide the device towards your right hand side, until the holders on the mounting plate fasten securely onto the keyholes of the device.



**Figure 2-9 Ceiling Mounting**

### **Mounting AP-8100 to AP-800/8000 mounting plate (Optional)**

In case, you are mounting AP-8100 to an already installed AP-800/8000 [Mounting Plate](#) (P/N 67439), then follow the following steps.

### **Wall Mounting:**

1. Hold the device such that the 'Reload' is towards your right hand side and the 'LEDs' towards left hand side.
2. Align the two keyholes on the device with the two holders on the mounting plate.
3. Carefully, slide down the device until the holders on the mounting plate fasten securely onto the keyholes of the device.

**Ceiling Mounting:**

1. Hold the device such that the rear panel of the device is facing the mounting plate, with 'Reload' towards your right hand side and 'LEDs' towards left hand side.
2. Align the two keyholes on the device with the two holders on the mounting plate.
3. Carefully, slide the device backwards until the holders on the mounting plate fasten securely onto the keyholes of the device.



: Ensure that the mounting plate is fixed in the similar fashion, as described in AP-800/AP-8000 mounting procedures (See [Installation Procedure](#)).

**2.3.5.3 Step 3: Power On the Device**

To power on the device, plug in the power cord into a power outlet. There is no ON/OFF switch on the device. To disconnect power:

- Unplug the power cable from the power socket of the device, if using power adapter.
- Unplug the RJ45 connector from the **Data & Power Out** port on the DC injector, if using the Gigabit Ethernet PoE.

**2.3.5.4 Step 4: View LEDs**

When the device is powered on, it performs startup diagnostics. When startup is complete, the LEDs show the operational state of the device. Tabulated below is the behavior of the four LEDs on the device.

LED	Symbol	Behavior	Color
<b>Power LED</b>		Glows green when the AP-8100 device is switched ON.	
<b>Ethernet LED</b>		<ul style="list-style-type: none"> <li>• Glows green when the AP-8100 device is connected to a 1 Gbps link.</li> <li>• Blinks green when the AP-8100 device traffic is being transmitted or received on the 1 Gbps link.</li> </ul>	
		<ul style="list-style-type: none"> <li>• Glows amber when the AP-8100 device is connected to a 100 Mbps link.</li> <li>• Blinks amber when the AP-8100 device traffic is being transmitted or received on the 100 Mbps link.</li> </ul>	
		<ul style="list-style-type: none"> <li>• Glows red when the AP-8100 device is connected to a 10 Mbps link.</li> <li>• Blinks red when the AP-8100 device traffic is being transmitted or received on the 10 Mbps link.</li> </ul>	
<b>2.4 GHz LED</b>	2.4G	<ul style="list-style-type: none"> <li>• Glows green when the AP-8100 device wireless interface 2 is in operational state.</li> <li>• Blinks green when the AP-8100 device wireless traffic is being transmitted or received.</li> </ul>	
<b>5 GHz LED</b>	5G	<ul style="list-style-type: none"> <li>• Glows green when the AP-8100 device wireless interface 1 is in operational state.</li> <li>• Blinks green when the AP-8100 device wireless traffic is being transmitted or received.</li> </ul>	



: When the Reload button is pressed, the Power LED glows **amber**.

## 2.4 ORiNOCO® AP-9100

### 2.4.1 Front View of the Device

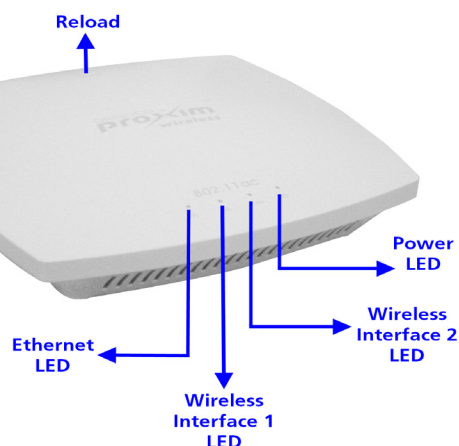



Figure 2-10 Front View of the AP-9100

The front panel of the device contains the following components:

#### 2.4.1.1 LED Indicators

Tabulated below are the four LEDs, that are available on the front panel of the device:

LED	Symbol	Description
Ethernet LED		This LED indicates the status of the traffic over the wired ethernet LAN.
5G (Wireless Interface 1) LED	5G	This LED indicates the status of the traffic over the wireless interface (radio) 1. Refer <a href="#">Device Operational Modes</a> .
2.4G (Wireless Interface 2) LED	2.4G	This LED indicates the status of the traffic over the wireless interface (radio) 2. Refer <a href="#">Device Operational Modes</a> .
Power LED		This LED indicates whether the device is switched ON/OFF.

#### 2.4.1.2 Reload

Reload button helps to restore the device to factory default configuration, when:

- The device cannot be accessed through web interface or command line interface.
- The device does not initialize.
- The password is lost.

To avoid tampering, you can lock the reload button on the device and disable the reload functionality. For more details, refer to the *Reload* feature and *Recovery Procedures* illustrated in *ORiNOCO® 802.11n & 802.11ac Access Points - Software Management Guide*.

## 2.4.2 Rear View of the Device

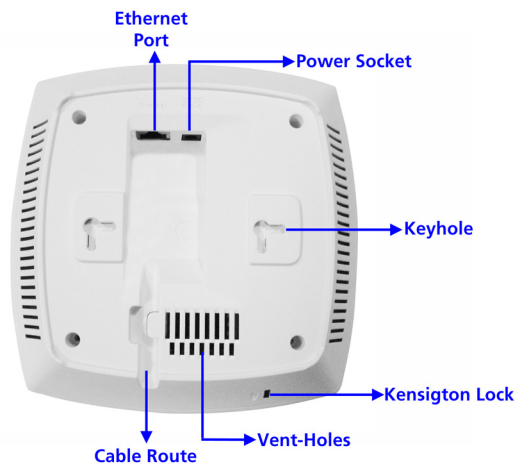

Figure 2-11 Rear View of the Device

The rear panel of the device contains the following components:

### 2.4.2.1 Ethernet Port

The Ethernet port of the device allows the user to connect to the LAN by using CAT5e / CAT6 ethernet cable.

### 2.4.2.2 Power Socket

This socket connects to the 12 VDC power adapter.

### 2.4.2.3 Keyhole

A provision to fix the device onto the mounting plate.

### 2.4.2.4 Kensington Lock

A security slot to lock the device.

### 2.4.2.5 Cable Route

A slot for the CAT5e / CAT6 ethernet cable and the power cable to rest securely.

### 2.4.2.6 Vent-Holes

Ventilation holes on the device allow heat dissipation.

## 2.4.3 System Requirements

Following are the minimum system requirements to use the device:





1. Any 802.11 compliant wireless adapter.
2. A computer that is connected to the same IP network as the AP and has one of the following installed:
  - Web Browser
  - Telnet
  - MIB Browser
  - Ethernet NIC Card
3. Ethernet switch, cross-over or straight Ethernet cable.



- A 12V DC Power Adapter or a Power over Ethernet (PoE) Adapter.

### 2.4.4 Product Package

Each shipment includes the items listed in the following table. Please verify that you have received all the parts in the shipment, prior to the installation.

What's in the Kit	Image										
ORiNOCO® AP-9100											
Power adapter with Country specific Power Plug(s) <table border="1" data-bbox="324 877 592 1012"> <thead> <tr> <th>SKU</th> <th>Power Plug(s)</th> </tr> </thead> <tbody> <tr> <td>WD</td> <td>US, UK, EU</td> </tr> <tr> <td>US</td> <td>US</td> </tr> <tr> <td>JP</td> <td>US</td> </tr> <tr> <td>EU</td> <td>UK, EU</td> </tr> </tbody> </table>	SKU	Power Plug(s)	WD	US, UK, EU	US	US	JP	US	EU	UK, EU	
SKU	Power Plug(s)										
WD	US, UK, EU										
US	US										
JP	US										
EU	UK, EU										
Mounting Kit											
Quick Installation Guide (QIG)											

### 2.4.4.1 Optional Accessories

Tabulated below are the recommended optional accessories, that are supplied on request from Proxim Wireless Corporation.

Accessory	Part Number	Image	Description
PoE Adapter (US/CAN/JP Power Cord)	76282		PoE module helps you to power ON the device via ethernet cabling.
PoE Adapter (EU Power Cord)	76288		
PoE Adapter (UK Power Cord)	76287		

## 2.4.5 Installation Procedure

Perform the following steps to mount and install the device.

### 2.4.5.1 Step 1: Plugging in the Cables

#### Cabling with Power Adapter (Supplied with the product package)

To plug in the cables by using a 12V DC power adapter:

- Connect one end of the CAT5E/CAT6 Ethernet cable to the device's ethernet port and the other end to a PC.
- Plug the barrel of the power cable into the device's power socket, only after the device installation is complete.



: Use a cable-tie to ensure that the power cable stays intact with the device power socket.

#### Cabling with Gigabit PoE (Not supplied with the product package)

To use Power over Ethernet (PoE), we recommend you to use our Gigabit Ethernet PoE adapter ORiNOCO 1-Port Active Ethernet DC Injector (See [Optional Accessories](#)) and follow the following guidelines:

- Connect one end of the ethernet cable to the **Data In** port of the DC Injector and the other end to a PC.
- Connect one end of the second ethernet cable to the device's ethernet port, and the other end to the **Data & Power Out** Port of the DC Injector, only after the device installation is complete.



: PoE should be installed only in an indoor network, maintaining a controlled temperature.

### 2.4.5.2 Step 2: Mount the Device

Consider the following precautions, before mounting the device:

- The device must be protected from exposure, and the environmental conditions must be within those specified in the product datasheet that can be found at <http://support.proxim.com>.
- Ensure to use a +12V/1.25 A power adapter, to power on the device.
- Ensure that there is no power supply, until the device installation is complete.



- Note that the device is build with fire retardant FR3020 material and can be installed in the plenum. In an office building, plenum is the space between the structural ceiling and the tile ceiling that is provided to help air circulate. Many companies also use the plenum to house communication equipment and cables. These products and cables must comply with certain safety requirements, such as Underwriter Labs (UL) and Standard 2043: "Standards for Fire Test for Heat and Visible Smoke Release for Direct Products and Their Accessories installed in Air-Handling Spaces".
- When installed in a plenum, the device must use PoE.

Conduct a site survey to determine the best location for the device. You can either mount the device to a wall or mount it to the T-bar ceiling, as follows:

**Wall-Mounting:**

To mount the device to a wall:

1. Place the mounting plate on the wall such that the embossed letter 'L' is at the top-center position and the vent-holes are facing your left hand side.

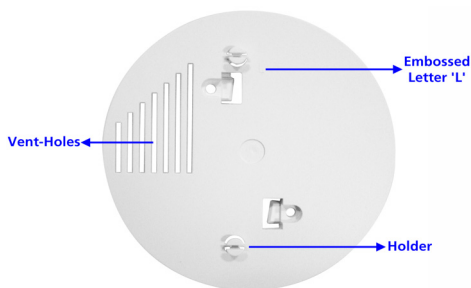

**Figure 2-12 Mounting Plate**

2. Fasten the mounting plate by using a pair of plastic anchors and screws provided with the product package.
3. Hold the device in the upright position (with 'Reload' on top and the 'LEDs' at the bottom), such that the vent-holes on the device and the vent-holes on the mounting plate rest on each other.
4. Align the two keyholes on the device with the two holders on the mounting plate.
5. Carefully, slide the device towards your right hand side, until the holders on the mounting plate fasten securely onto the keyholes of the device.

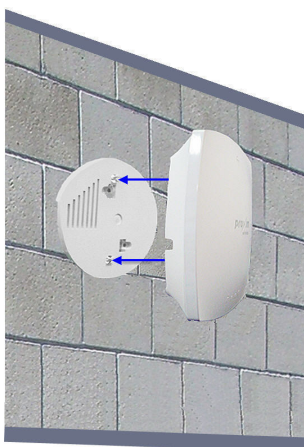

**Figure 2-13 Wall Mounting**

**Ceiling Mounting:**

1. Place the mounting plate on the T-bar ceiling such that the embossed letter 'L' is at the top-center position and the vent-holes are facing your left hand side.
2. Fasten the mounting plate by using a pair of plastic anchors and screws provided with the product package.
3. Hold the device with its rear panel facing the mounting plate, such that the vent-holes on the device and the vent-holes on the mounting plate rest on each other.
4. Align the two keyholes on the device with the two holders on the mounting plate.
5. Carefully, slide the device towards your right hand side, until the holders on the mounting plate fasten securely onto the keyholes of the device.

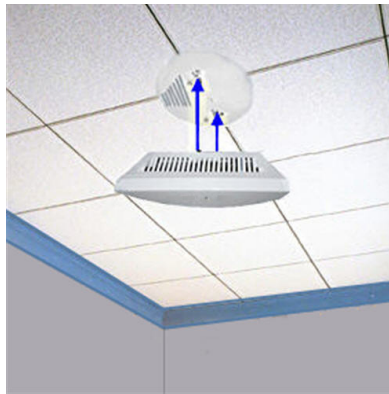

**Figure 2-14 Ceiling Mounting**

**Mounting AP- 9100 to AP-800/AP-8000 mounting plate (Optional)**

In case, you are mounting AP-9100 to an already installed AP-800/AP-8000 [Mounting Plate](#) (P/N 67439), then follow the following steps.

**Wall Mounting:**

1. Hold the device such that the 'Reload' is towards your right hand side and the 'LEDs' towards left hand side.
2. Align the two keyholes on the device with the two holders on the mounting plate.
3. Carefully, slide down the device until the holders on the mounting plate fasten securely onto the keyholes of the device.

**Ceiling Mounting:**

1. Hold the device such that the rear panel of the device is facing the mounting plate, with 'Reload' towards your right hand side and 'LEDs' towards left hand side.
2. Align the two keyholes on the device with the two holders on the mounting plate.
3. Carefully, slide the device backwards until the holders on the mounting plate fasten securely onto the keyholes of the device.



*Ensure that the mounting plate is fixed in the similar fashion, as described in AP-800/AP-8000 mounting procedures (See [Installation Procedure](#)).*

**2.4.5.3 Step 3: Power On the Device**









To power on the device, plug in the power cord into a power outlet. There is no ON/OFF switch on the device. To disconnect power:

- Unplug the power cable from the power socket of the device, if using power adapter.

- Unplug the RJ45 connector from the **Data & Power Out** port on the DC injector, if using the Gigabit Ethernet PoE.

**2.4.5.4 Step 4: View LEDs**

When the device is powered on, it performs startup diagnostics. When startup is complete, the LEDs show the operational state of the device. Tabulated below is the behavior of the four LEDs on the device.

LED	Symbol	Behavior	Color
Ethernet LED		<ul style="list-style-type: none"> <li>• Glows green when the AP-9100 device is connected to a 1 Gbps link.</li> <li>• Blinks green when the AP-9100 device traffic is being transmitted or received on the 1 Gbps link.</li> </ul>	
		<ul style="list-style-type: none"> <li>• Glows amber when the AP-9100 device is connected to a 100 Mbps link.</li> <li>• Blinks amber when the AP-9100 device traffic is being transmitted or received on the 100 Mbps link.</li> </ul>	
		<ul style="list-style-type: none"> <li>• Glows yellow when the AP-9100 device is connected to a 10 Mbps link.</li> <li>• Blinks yellow when the AP-9100 device traffic is being transmitted or received on the 10 Mbps link.</li> </ul>	
5 GHz LED	5G	<ul style="list-style-type: none"> <li>• Glows green when the AP-9100 device wireless interface 1 is in operational state.</li> <li>• Blinks green when the AP-9100 device wireless traffic is being transmitted or received.</li> </ul>	
2.4 GHz LED	2.4G	<ul style="list-style-type: none"> <li>• Glows green when the AP-9100 device wireless interface 2 is in operational state.</li> <li>• Blinks green when the AP-9100 device wireless traffic is being transmitted or received.</li> </ul>	
Power LED		<ul style="list-style-type: none"> <li>• Glows green when the AP-9100 device is switched ON.</li> </ul>	



: When the Reload button is pressed, the Power LED blinks in **green**.

---

## Hardware Specifications

This chapter covers the hardware specifications of the following products:

- [ORiNOCO® AP-800 and AP-8000](#)
- [ORiNOCO® AP-8100](#)
- [ORiNOCO® AP-9100](#)

### 3.1 ORiNOCO® AP-800 and AP-8000

Category	Specification														
Radio Module	Single Radio Access Point (AP-800) / Dual Radio Access Point (AP-8000) 3x3 MIMO per radio. Refer <a href="#">Device Operational Modes</a> .														
Wireless Protocol	802.11a/n 802.11a 802.11b/g/n 802.11g														
Frequency	5.150 - 5.850 GHz* 2.4 - 2.483 GHz* * Subject to Individual Country Regulations														
Channel bandwidth	20MHz and 40MHz for 802.11n 20MHz for 802.11a/b/g														
Modulation	<ul style="list-style-type: none"> <li>MCS0 - MCS15 for 802.11n (6.5 Mbps -300 Mbps)</li> <li>BPSK, QPSK, 16-QAM and 64-QAM for 802.11a and 802.11g (6 Mbps - 54 Mbps)</li> <li>DSSS for 802.11b (1 Mbps -11 Mbps)</li> </ul>														
Device Interface	<b>Ethernet:</b> Auto-sensing 10/100/1000BASE-T Ethernet <b>Antenna Connector:</b> 3 RP-SMA connectors for AP-800 6 RP-SMA connectors for AP-8000														
LED Indicators	Refer <a href="#">Step 5: View LEDs</a>														
Antennas	3 Single-Band (AP-800) / 6 Dual-Band (AP-8000) Omni-Antennas and reverse SMA connector with 3 dBi gain.														
Network Architecture Type	Infrastructure														
Transmit Power	<table border="1"> <thead> <tr> <th rowspan="2">Operational Modes</th> <th colspan="2">Transmit Power* (dBm)</th> </tr> <tr> <th>20 MHz</th> <th>40 MHz</th> </tr> </thead> <tbody> <tr> <td>802.11b</td> <td>19</td> <td>-</td> </tr> <tr> <td>802.11a/g</td> <td>17</td> <td>-</td> </tr> <tr> <td>802.11na/ng</td> <td>16</td> <td>14</td> </tr> </tbody> </table> <p>* Combined Tx Power values</p>	Operational Modes	Transmit Power* (dBm)		20 MHz	40 MHz	802.11b	19	-	802.11a/g	17	-	802.11na/ng	16	14
Operational Modes	Transmit Power* (dBm)														
	20 MHz	40 MHz													
802.11b	19	-													
802.11a/g	17	-													
802.11na/ng	16	14													

Receive Sensitivity	<table border="1"> <thead> <tr> <th colspan="2">11b</th> <th colspan="2">11a/g</th> <th colspan="2">11n</th> </tr> <tr> <th>Data Rate (Mbps)</th> <th>Receive Sensitivity (2.4-5Ghz)</th> <th>Data Rate (Mbps)</th> <th>Receive Sensitivity (2.4-5Ghz)</th> <th>Data Rate (MCS*)</th> <th>Receive Sensitivity (2.4-5Ghz)</th> </tr> </thead> <tbody> <tr> <td>1</td> <td>-94</td> <td>6</td> <td>-96</td> <td>MCS 0</td> <td>-90</td> </tr> <tr> <td>11</td> <td>-91</td> <td>36</td> <td>-87</td> <td>MCS 8</td> <td>-91</td> </tr> <tr> <td>-</td> <td>-</td> <td>48</td> <td>-83</td> <td>MCS 10</td> <td>-83</td> </tr> <tr> <td>-</td> <td>-</td> <td>54</td> <td>-82</td> <td>MCS 15</td> <td>-72</td> </tr> </tbody> </table> <p><i>*MCS refers to Modulation Coding Scheme.</i></p>	11b		11a/g		11n		Data Rate (Mbps)	Receive Sensitivity (2.4-5Ghz)	Data Rate (Mbps)	Receive Sensitivity (2.4-5Ghz)	Data Rate (MCS*)	Receive Sensitivity (2.4-5Ghz)	1	-94	6	-96	MCS 0	-90	11	-91	36	-87	MCS 8	-91	-	-	48	-83	MCS 10	-83	-	-	54	-82	MCS 15	-72
11b		11a/g		11n																																	
Data Rate (Mbps)	Receive Sensitivity (2.4-5Ghz)	Data Rate (Mbps)	Receive Sensitivity (2.4-5Ghz)	Data Rate (MCS*)	Receive Sensitivity (2.4-5Ghz)																																
1	-94	6	-96	MCS 0	-90																																
11	-91	36	-87	MCS 8	-91																																
-	-	48	-83	MCS 10	-83																																
-	-	54	-82	MCS 15	-72																																
Local Configuration Support	RS-232 Serial port, DB9 Female																																				
Remote Configuration Support	Telnet and SSH, Web GUI (http) and SSL (https), TFTP SNMP v1, v2c and v3 SNMP trap and Syslog PVES (ProximVision ES Network Management Systems)																																				
Message Authentication	802.11i AES message authentication with 128 bit keys TKIP with 128 bit Michael Message Integrity Check																																				
Intrusion detection	Detect MIC intrusion attacks																																				
Dimensions (L x W x H)	11.1 x 6.85 x 1.89 in. (282 x 174 x 48 mm)  : These dimensions exclude the antennas.																																				
Weight	<b>AP-800</b> - 0.7 Kgs (1.54 lbs) <b>AP-8000</b> - 0.75 Kgs (1.65 lbs)																																				
Environmental	<b>Operating Temperatures:</b> 0 to 55°C 5 to 95 percent (non-condensing) <b>Storage Temperature:</b> -20° to 75°C																																				
MTBF	43,800 hrs																																				
Warranty	One year parts/labor																																				



### 3.1.1 Antenna Specifications

- Omni Directional Antenna (Supplied with the Product)
- Range Extender Antenna (REA) (Not Supplied with the product)

#### 3.1.1.1 Omni Directional Antenna Specifications



Feature	Electrical Specifications	
Frequency Range	2400 MHz - 2500 MHz	4900 MHz – 5875 MHz
Peak Gain	2.5 dBi	5 dBi
Average Gain	1.5 dBi	3 dBi
VSWR	2.0 : 1 Max	
Polarization	Linear, Vertical	
HPBW/Horizontal	360°	360°
HPBW/Vertical	50°	25°
Power Handling	2W (cw)	
Impedence	50 Ohms	
Connector	RP SMA Plug	

Feature	Environmental and Mechanical Specification
Temperature	-10°C to +55°C
Humidity	95% @55°C
Radome color	White
Radome material	ABS, UV resistant
Weight	21 g
Dimensions	19 x 39 x 127 mm
Power Handling	2W (cw)

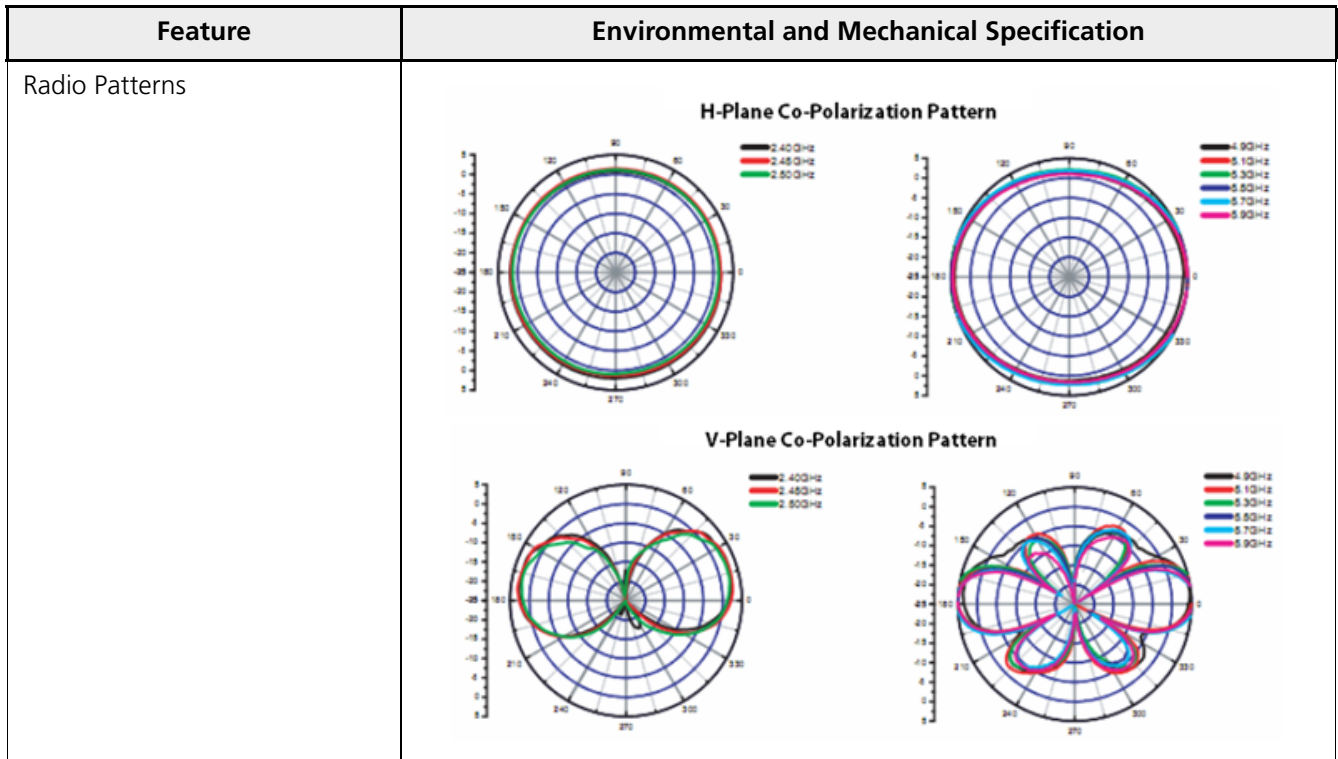

**3.1.1.2 Range Extender Antenna (REA) Specifications**



Feature	Electrical Specifications	
Frequency Range	2400 MHz - 2500 MHz	4900 MHz – 5875 MHz
Peak Gain	3 dBi	6 dBi
VSWR	2.0 : 1 Max	2.5 : 1 Max
Polarization	Linear, Vertical	
HPBW/Horizontal	360°	360°

Feature	Electrical Specifications	
HPBW/Vertical	35° - 50°	17° - 27°
Power Handling	2W (cw)	
Impedence	50 Ohms	
Cable	ULA100-3F, White, 1.5 m	
Connector	RP SMA Plug x 3 (Quick Connector)	
Lightning Protection	N/A	
* Exclusive of cable loss 2.5 dB @ 2.4 GHz and 5 dB @ 5.5 GHz		

Feature	Environmental and Mechanical Specification
Temperature	-10°C to +55°C
Humidity	95% @55°C
Radome color	White
Radome material	ABS, UV resistant
Weight	0.2 g
Dimensions	76.6 x 185 mm
Mounting Kit	Desktop Mount and Ceiling mount

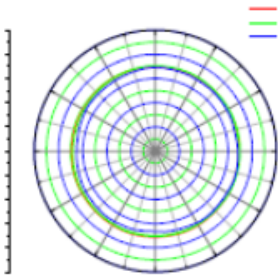
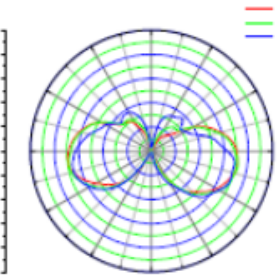
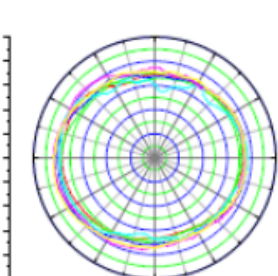
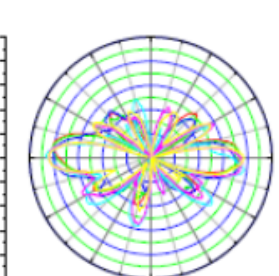
Feature	Environmental and Mechanical Specification
Radio Patterns	<div style="display: flex; justify-content: space-around; align-items: center;"> <div style="text-align: center;"> <p><b>H-plane</b></p>  </div> <div style="text-align: center;"> <p><b>V-plane</b></p>  </div> </div> <div style="display: flex; justify-content: space-around; align-items: center;"> <div style="text-align: center;"> <p><b>H-plane</b></p>  </div> <div style="text-align: center;"> <p><b>V-plane</b></p>  </div> </div>

### 3.2 ORiNOCO® AP-8100

Category	Specification
Power Requirements	<b>Power Adapter:</b> 12V/1.25A <b>Power over Ethernet (PoE) (optional):</b> 48V / Any 802.3af compliant Gigabit PoE
Radio Module	Dual Radio Access Point, 2x2 MIMO per radio Radio1: IEEE 802.11a/n Radio2: IEEE 802.11b/g/n Refer <a href="#">Device Operational Modes</a> .
Wireless Protocol	802.11a/n 802.11a 802.11g 802.11b/g/n
Frequency	5.150 - 5.850 GHz* 2.4 - 2.483 GHz * Subject to Individual Country Regulations
Channel bandwidth	20MHz and 40MHz for 802.11n 20MHz for 802.11a/b/g
Modulation	<ul style="list-style-type: none"> <li>• BPSK, QPSK, 16-QAM and 64-QAM: <ul style="list-style-type: none"> <li>– With data rates of 6.5 Mbps -300 Mbps for 802.11n</li> <li>– With data rates of 6 Mbps - 54 Mbps for 802.11a and 802.11g</li> </ul> </li> <li>• DSSS, CCK: With data rates of 1 Mbps -11 Mbps for 802.11b</li> </ul>
Device Interface	<b>Ethernet:</b> Auto-sensing 10/100/1000BASE-T Ethernet
LED Indicators	Refer <a href="#">Step 4: View LEDs</a>
Antennas	4 Modular High Efficiency built-in PIFA Antennas with a peak gain of: <ul style="list-style-type: none"> <li>– 3dBi for 2.4 GHz frequency.</li> <li>– 4dBi for 5 GHz frequency.</li> </ul>
Network Architecture Type	Infrastructure
 <i>The operational mode 'g/n' is backward compatible to mode 'b'.</i>	

Transmit Power	<b>AP-8100</b>						
	<b>11b</b>		<b>11a/g</b>		<b>11n</b>		
	<b>Data Rates (Mbps)</b>	<b>Transmission Power* (dBm)</b>	<b>Data Rates (Mbps)</b>	<b>Transmission Power* (dBm)</b>	<b>Data Rate (MCS*)</b>	<b>Transmission Power* (dBm)</b>	
	1 to 11	20	6 to 48	20	MCS (0 to 5)	20	
					MCS 6	19	
		54	20	MCS 7	17		
<p>* Combined Tx Power values                  * MCS refers to Modulation Coding Scheme.</p>							
Receive Sensitivity	<b>AP-8100</b>						
	<b>11b</b>		<b>11a/g</b>		<b>11n</b>		
	<b>Data Rate (Mbps)</b>	<b>Receive Sensitivity (2.4-5Ghz)</b>	<b>Data Rate (Mbps)</b>	<b>Receive Sensitivity (2.4-5Ghz)</b>	<b>Data Rate (MCS*)</b>	<b>Receive Sensitivity (2.4/5Ghz)</b>	
	1	-93	6	-90	MCS 0	20 MHz	40 MHz
						-87	-86
11	-90	54	-75	MCS 7	-70	-66	
<p>* MCS refers to Modulation Coding Scheme.</p>							
Remote Configuration Support	Telnet and SSH, Web GUI (http) and SSL (https), TFTP SNMP v1, v2c and v3 SNMP trap and Syslog PVES (ProximVision ES Network Management Systems)						
Message Authentication	802.11i AES message authentication with 128 bit keys TKIP with 128 bit Michael Message Integrity Check						
Intrusion detection	Detect MIC intrusion attacks						
Dimensions (L x W x H)	6.69 x 6.69 x 1.74 in. (170 x 170 x 44.1 mm)						
Weight	0.340 kg (0.75 lbs)						
Environmental	<p><b>Operating Temperatures:</b>                  0 to 45°C                  5 to 95 percent (non-condensing)  <b>Storage Temperature:</b>                  - 40° to 70°C</p>						
MTBF	>100,000 hrs						
Warranty	One year parts/labor						

### 3.2.1 Antenna Specifications

Feature	Specification	
Frequency Range	2.4 GHz - 2.5 GHz	5.1 GHz – 5.825 GHz
Peak Gain	3.0 dBi	4.0 dBi
VSWR	2.0 : 1	2.0 : 1
Isolation (db)	> 20	> 15
Impedence	50 Ohms	
Max.Power	1 Watts	
Weight	11 g	
Connector	IPEX	
Cable Length (mm)	TBD	
Dimension (mm)	90.4 x 86 x 10	

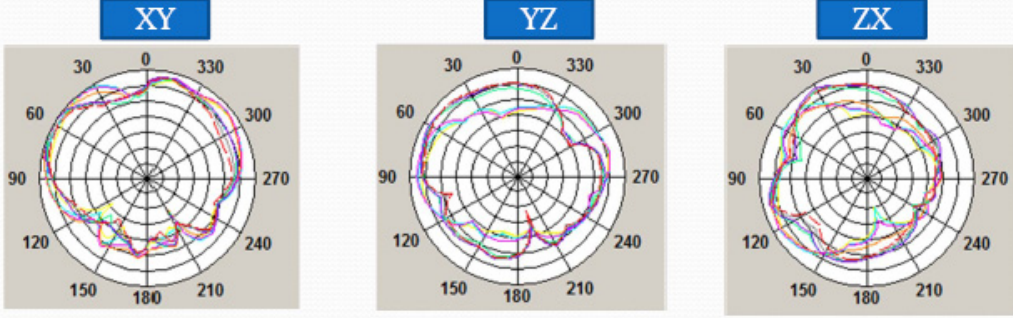
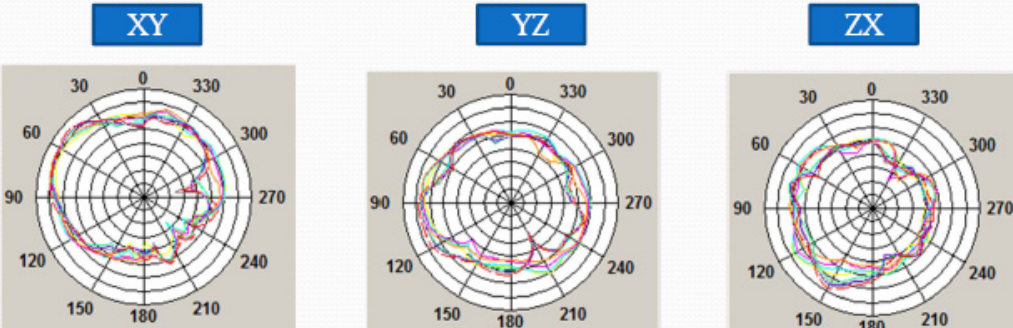
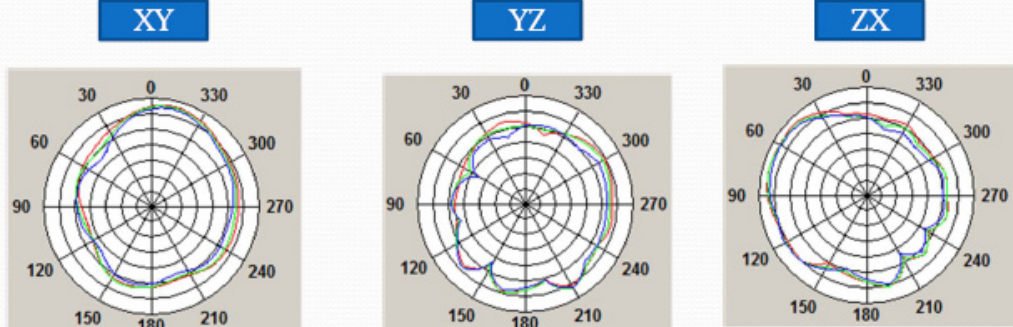
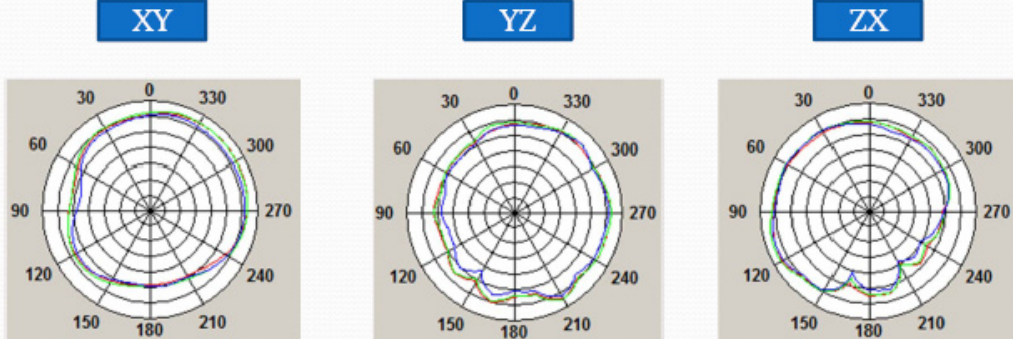
AP-8100	
Feature	Specification
Radio Patterns Radio - 1(5 GHz)	<p>Port-1</p>  <p>Port-2</p> 
	<p>Port-1</p>  <p>Port-2</p> 



### 3.3 ORiNOCO® AP-9100

Category	Specification
Power Requirements	<b>Power Adapter:</b> 12V/1.25A <b>Power over Ethernet (PoE) (optional):</b> 48V / Any 802.3af compliant Gigabit PoE
Radio Module	Dual Radio Access Point, 3x3 MIMO per radio Radio1: IEEE 802.11a/n/ac (5 GHz) Radio2: IEEE 802.11b/g/n(2.4 GHz) Refer <a href="#">Device Operational Modes</a> .
Wireless Protocol	802.11b/g/n 802.11ac
Frequency	5.150 GHz – 5.850 GHz 2.400 GHz – 2.484 GHz * Subject to Individual Country Regulations
Channel bandwidth	20MHz and 40MHz for 802.11b/g/n 20MHz, 40MHz and 80 MHz for 802.11ac
Modulation	<ul style="list-style-type: none"> <li>• BPSK, QPSK, 16-QAM, 64-QAM and 256-QAM <ul style="list-style-type: none"> <li>– With data rates up to 450 Mbps for 802.11b/g/n (3x3 MIMO)</li> <li>– With data rates up to 1300 Mbps for 802.11a/n/ac (3x3 MIMO)</li> <li>– With data rates up to 866.7 Mbps for 802.11ac (2x2 MIMO)</li> </ul> </li> </ul>
Device Interface	<b>Ethernet:</b> Auto-sensing 10/100/1000BASE-T Ethernet
LED Indicators	Refer <a href="#">Step 4: View LEDs</a>
Antennas	6 Modular High Efficiency built-in PIFA Antennas with a peak gain of: <ul style="list-style-type: none"> <li>– 4.46dBi for (2.400 to 2.484) GHz frequency.</li> <li>– 5.0dBi for (5.150 to 5.850) GHz frequency.</li> </ul>
Network Architecture Type	Infrastructure
 The operational mode 'g/n' is backward compatible to mode 'b'.	

Receive Sensitivity	<b>Rx Sensitivity Values for Wireless Interface Radio1 &amp; Wireless Interface Radio2:</b>							
	<b>AP-9100 (Wireless Interface Radio1)</b>							
	<b>11ac</b>			<b>11n</b>			<b>11a</b>	
	<b>Data Rate (MCS*)</b>	<b>Receiver Sensitivity (dBm)</b>			<b>Receiver Sensitivity (dBm)</b>		<b>Data Rate (Mbps)</b>	<b>Receiver Sensitivity (dBm)</b>
		<b>HT20 (at 5 GHz)</b>	<b>HT40 (at 5 GHz)</b>	<b>VHT80 (at 5 GHz)</b>	<b>HT20 (at 5 GHz)</b>	<b>HT40 (at 5 GHz)</b>		
	MCS 0	-92	-90	-87	-92	-91	6	-92
	MCS 9	--	-63	-60	--	--	54	-75
	MCS 8	-67	--	--	-92	-91		
	<b>AP-9100 (Wireless Interface Radio2)</b>							
	<b>11b</b>		<b>11g</b>		<b>11n</b>			
<b>Data Rates (Mbps)</b>	<b>Receiver Sensitivity (dBm)</b>	<b>Data Rates (Mbps)</b>	<b>Receiver Sensitivity (dBm)</b>	<b>Data Rate (MCS*)</b>	<b>Receiver Sensitivity (dBm)</b>			
					<b>HT20 (at 2.4 GHz)</b>	<b>HT40 (at 2.4 GHz)</b>		
1	-95	6	-90	MCS 0/8/16	-91	-88		
11	-90	54	-76		-73	-72		
				MCS 7/15/23				
<p>* MCS refers to Modulation Coding Scheme.                  * HT refers to High Throughput.                  * VHT refers to Very High Throughput</p>								
Remote Configuration Support	Telnet and SSH, Web GUI (http) and SSL (https), TFTP SNMP v1, v2c and v3 SNMP trap and Syslog PVNMS v1.3.2							
Message Authentication	802.11i AES message authentication with 128 bit keys TKIP with 128 bit Michael Message Integrity Check							
Intrusion detection	Detect MIC intrusion attacks							
Dimensions (L x W x H)	6.69 x 6.69 x 1.74 in. (170 x 170 x 44.1 mm)							

Weight	0.400 kg (0.88 lbs)
Environmental	<b>Operating Temperatures:</b> 0 to 40°C (32°F to 104°F) <b>Storage Temperature:</b> - 20° to 60°C (-4°F to 140°F)
Humidity (non-condensing)	5% ~ 90% typical
MTBF	>500,000 hrs
Power Consumption	< 12.9 watts
Warranty	One year parts/labor

### 3.3.1 Antenna Specifications

Feature	Specification	
Frequency Range	2.400 GHz - 2.484 GHz	5.150 GHz – 5.850 GHz
Peak Gain	4.46 dBi	5.0 dBi
VSWR	2.0 : 1	2.0 : 1
Isolation (db)	> 25	
Impedence	48 Ohms	
Max.Power	2 Watts	
Weight	10 g	
Connector	IPEX	
Cable Length (mm)	100~180	
Dimension (mm)	90 x 90 x 10	

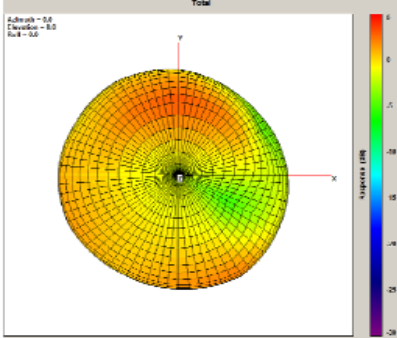
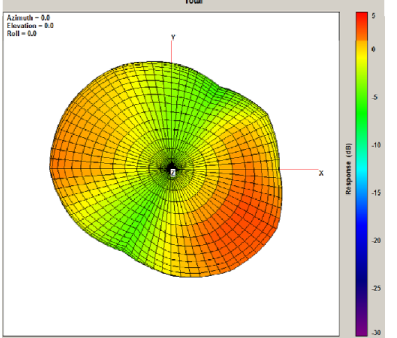
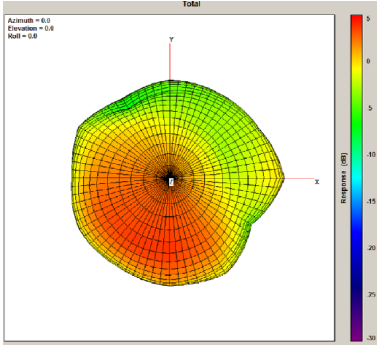
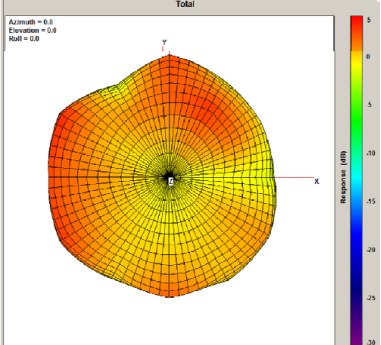
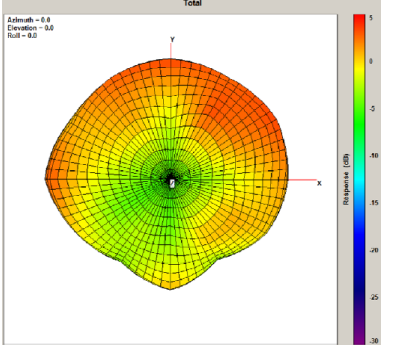
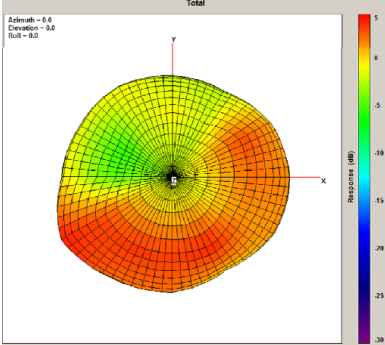
AP-9100	
Feature	Specification
Radio Patterns Radio - 1(2.45 GHz)	<div style="display: flex; justify-content: space-around;"> <div style="text-align: center;"> <p>Antenna-1</p>  </div> <div style="text-align: center;"> <p>Antenna-2</p>  </div> </div> <div style="text-align: center; margin-top: 20px;"> <p>Antenna-3</p>  </div>
Radio Patterns Radio - 2(5.55 GHz)	<div style="display: flex; justify-content: space-around;"> <div style="text-align: center;"> <p>Antenna-4</p>  </div> <div style="text-align: center;"> <p>Antenna-5</p>  </div> </div> <div style="text-align: center; margin-top: 20px;"> <p>Antenna-6</p>  </div>

### 3.3.2 IEEE Spectral Mask Specifications:

Wireless Interface Radio1 & Radio2 of the AP-9100 device comply with the IEEE Spectral Mask Specifications.

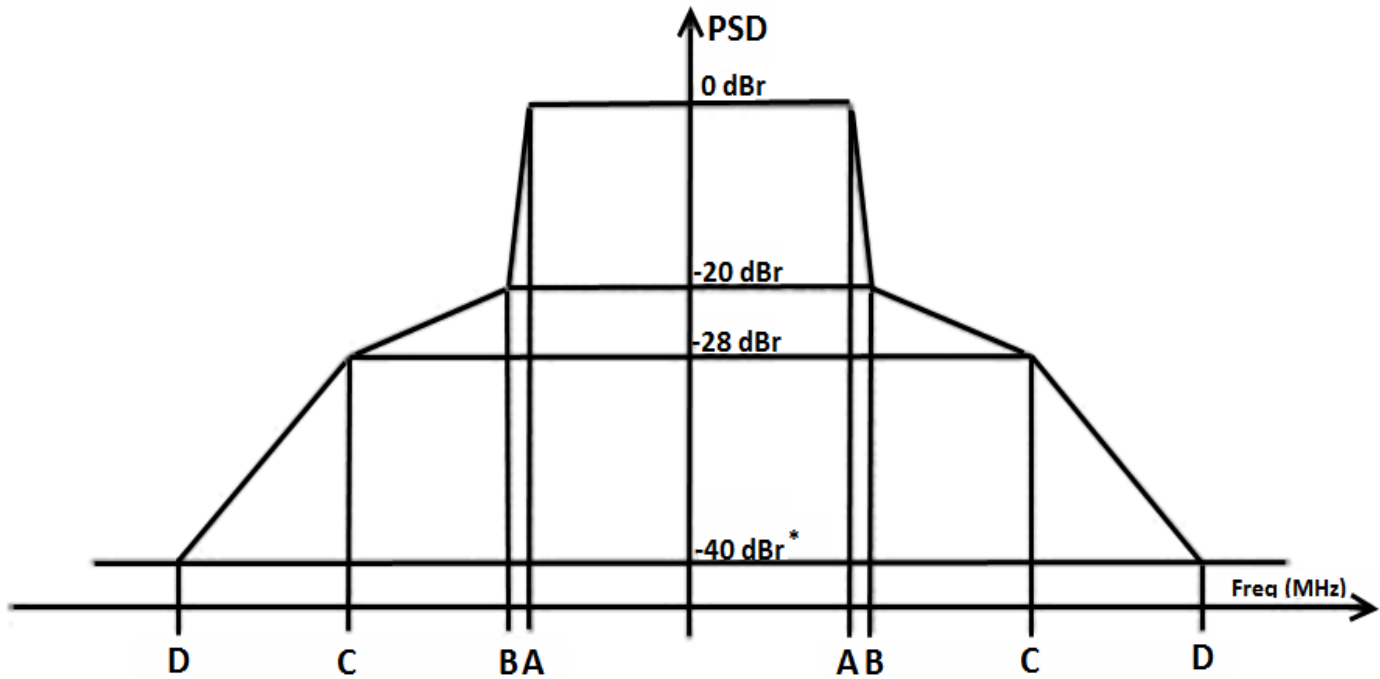

Wireless Interface Radio1

Signal Bandwidth Under Test	A	B	C	D	*Maximum of:
20 MHz	9	11	20	30	-40 dBr & -53 dBm/MHz
40 MHz	19	21	40	60	-40 dBr & -56 dBm/MHz
80 MHz	39	41	80	120	-40 dBr & -59 dBm/MHz

Wireless Interface Radio2

Signal Bandwidth Under Test	A	B	C	D	*Maximum of:
20 MHz	9	11	20	30	-40 dBr & -53 dBm/MHz
40 MHz	19	21	40	60	-40 dBr & -56 dBm/MHz

# A

## Glossary and Abbreviations

### Glossary

A	
Access point	A wireless network transceiver or “base station” hub, often used to connect a local area network to one or more wireless devices. An access point (also called AP) can provide a communication link to a wired local area network also.
Advanced Encryption Standard (AES)	It is a symmetric-key encryption standard, containing three block ciphers AES-128, AES-192, AES-256. Each of these ciphers has a 128-bit block size, with key sizes of 128, 192 and 256 bits, respectively.

D	
Dual-Band	Dual-band refers to a device's ability to function on two different frequency bands.

H	
HTTP/HTTPS	Hypertext Transfer Protocol (HTTP) is the protocol to transport Web pages. When you access the Internet with your browser, the HTTP protocol is used for data transport ( <a href="http://www.Tsunamiwireless.com">http://www.Tsunamiwireless.com</a> ). When you access the unit by using the Web Interface, HTTP is used to transport the information. HTTPS is the Secure Hypertext Transfer Protocol.

M	
Management Information Base (MIB)	A Management Information Base (MIB) is a formal description of a set of network objects that can be managed with the Simple Network Management Protocol (SNMP). A MIB can be loaded by a management application so that it knows the unit specific objects.

O	
Orthogonal Frequency Division Multiplexing (OFDM)	OFDM is a frequency-division multiplexing (FDM) scheme, a method of encoding digital data on multiple carrier frequencies. A large number of closely spaced orthogonal sub-carrier signals are used to carry data. The data is divided into several parallel data streams/channels, one for each sub-carrier, maintaining total data rates similar to conventional single-carrier modulation schemes in the same bandwidth.

<b>S</b>	
ScanTool	<p>Proxim’s ScanTool is a software utility that runs on Microsoft Windows machine. By using ScanTool, you can</p> <ul style="list-style-type: none"> <li>• Scan devices (Proxim devices only) available on the network</li> <li>• Obtain device’s IP address</li> <li>• Modify device’s IP Configuration parameters (IP Address, Address Type, Gateway and so on)</li> <li>• Launch the Web interface</li> <li>• Switch between the network adapters, if there are multiple network adapters in the Personal Computer</li> </ul>
Simple Network Management Protocol (SNMP)	<p>A protocol used for the communication between a network management application and the devices it is managing. The network management application is called the SNMP manager and the devices it manages will have SNMP agents. Not only the unit but also almost every network device contains a SNMP agent. The manageable objects of a device are arranged in a Management Information Base, also called MIB. The Simple Network Management Protocol (SNMP) allows managers and agents to communicate for accessing these objects.</p>
Single-Band	<p>Single-band refers to a device's ability to function only on one frequency band.</p>

<b>T</b>	
TCP / IP	<p>The TCP/IP internet-suite protocol describes a set of general design guidelines and implementations of specific networking protocols to enable computers to communicate over a network. TCP/IP provides end-to-end connectivity specifying how data should be formatted, addressed, transmitted, routed and received at the destination.</p>
Telnet	<p>Telnet is a network protocol used on the Internet or local area networks to access the command-line interface, on a remote host. Most network equipment and operating systems with a TCP/IP stack support a Telnet service for remote configuration.</p>
Trivial File Transfer Protocol (TFTP)	<p>Trivial File Transfer Protocol (TFTP) is a lightweight protocol for transferring files that is like a simple form of File Transfer Protocol (FTP). A TFTP client is implemented on the unit. By using the upload and download commands, the unit can copy a file to or from a TFTP server.</p>

<b>V</b>	
VLAN	<p>The Virtual Local Area Network (VLAN) feature helps in logical grouping of network host on different physical LAN segments, which can communicate with each other as if they are all on the same physical LAN segment.</p>

<b>W</b>	
WPA	Wi-Fi Protected Access is a security standard based on IEEE 802.11i specification, that provides a high level of wireless network security. It uses data encryption through the Temporal Key Integrity Protocol (TKIP). TKIP scrambles the keys and ensures that the keys are not tampered with. User authentication is performed through the Extensible Authentication Protocol (EAP), to ensure that only authorized network users can access the network.

**Abbreviations**

<b>A</b>	
AP	Access Point
AES	Advanced Encryption Standard
<b>C</b>	
CLI	Command Line Interface
<b>F</b>	
FCC	Federal Communications Commission
<b>G</b>	
Gbps	Gigabit Per Second
GPL	General Public License
<b>H</b>	
HTTP	HyperText Transfer Protocol
HTTPS	HyperText Transfer Protocol Secure
<b>I</b>	
IEEE	Institute of Electrical and Electronics Engineers
IP	Internet Protocol
IC	Industry Canada
<b>L</b>	
LAN	Local Area Network
LED	Light Emitting Diode
LGPL	Lesser General Public License
<b>M</b>	
MAN	Metropolitan Area Networks



Mbps	Megabits Per Second
MIMO	Multiple-input and multiple-output
MCS	Modulation Coding Scheme
<b>O</b>	
OFDM	Orthogonal Frequency Division Multiplexing
<b>P</b>	
PoE	Power Over Ethernet
PIFA	Planar Inverted 'F' Antenna
<b>S</b>	
SKU	Stock Keeping Unit
SNMP	Simple Network Management Protocol
SNTP	Simple Network Time Protocol
<b>T</b>	
TCP	Transmission Control Protocol
TFTP	Trivial File Transfer Protocol
TKIP	Temporal Key Integrity Protocol
<b>U</b>	
USM	User Security Model
<b>W</b>	
WLAN	Wireless Local Area Networks
WPA	Wi-Fi Protected Access

## Statement of Warranty

### Warranty Coverage

Proxim Wireless Corporation warrants that its products are manufactured solely from new parts, conform substantially to specifications, and will be free of defects in material and workmanship for a Warranty Period of 1 year from the date of purchase.

### Repair or Replacement

When Proxim determines that a returned product does not meet the warranted criteria during the warranty period, Proxim at its option, will either: (a) repair the defective product; (b) replace the defective product with a new or refurbished product that is at least equivalent to the original; or (c) refund the price paid for the defective product. Generally, products are repaired or replaced within thirty (30) business days of receipt of the product at a Proxim Logistical/Repair Center. The warranty period for repaired or replacement products is ninety (90) days or the remainder of the original warranty period, whichever is longer. These three alternatives constitute the customer's sole and exclusive remedy and Proxim's sole and exclusive liability under warranty provisions.

### Limitations of Warranty

Proxim's warranties do not apply to any product (hardware or software) which has (a) been subjected to abuse, misuse, neglect, accident, or mishandling, (b) been opened, repaired, modified, or altered by anyone other than Proxim, (c) been used for or subjected to applications, environments, or physical or electrical stress or conditions other than as intended and recommended by Proxim, (d) been improperly stored, transported, installed, or used, or (e) had its serial number or other identification markings altered or removed.

Buyers can contact Proxim Wireless Customer Service Center either by telephone or via web. Support and repair of products that are out of warranty will be subject to a fee. Contact information is shown below. Additional support information can be found at Proxim Wireless's web site at <http://support.proxim.com>.

Contact technical support via telephone as follows:

#### USA and Canada Customers

- **Phone:** +1-408-383-7700; +1-866-674-6626
- **Business Hours:** 24x7 live response. Tier 3 support: 8 a.m. to 5 p.m. M-F PDT (UTC/GMT -7 hrs)

#### International Customers

- **Phone:** +1-408-383-7700; 0800-916475 (France); 8-800-100-9485 (Russia)
- **Business Hours:** 24x7 live response. Tier 3 support: 8 a.m. to 5 p.m. M-F PDT (UTC/GMT -7 hrs)

### General Procedures

When contacting the Customer Service for support, Buyer should be prepared to provide the product description and serial number and a description of the problem. The serial number should be on the product.

In the event the Customer Service Center determines that the problem can be corrected with a software update, Buyer might be instructed to download the update from Proxim Wireless's web site or, if that's not possible, the update will be sent to Buyer. In the event the Customer Service Center instructs Buyer to return the product to Proxim Wireless for repair or replacement, the Customer Service Center will provide Buyer a Return Material Authorization ("RMA") number and shipping instructions. Buyer must return the defective product to Proxim Wireless, properly packaged to prevent damage, shipping prepaid, with the RMA number prominently displayed on the outside of the container.

Calls to the Customer Service Center for reasons other than product failure will not be accepted unless Buyer has purchased a Proxim Wireless Service Contract or the call is made within the warranty period. After the warranty period, Technical Support is fee based (detailed in [Technical Services and Support](#)).

If Proxim Wireless reasonably determines that a returned product is not defective or is not covered by the terms of this Warranty, Buyer shall be charged a service charge and return shipping charges.

## Other Information

### Search Knowledgebase

Proxim Wireless stores all resolved problems in a solution database at the following URL: <http://support.proxim.com>.

### Ask a Question or Open an Issue

Submit a question or open an issue to Proxim Wireless technical support staff at the following URL:  
<http://support.proxim.com/cgi-bin/proxim.cfg/php/enduser/ask.php>.

# Technical Services and Support

## Obtaining Technical Service and Support

If you are having trouble using the Proxim product, please read this guide and the additional documentation provided with your product. If you require additional support to resolve your issue, please be ready to provide the following information before you contact Proxim's Technical Services team:

- Product information
  - Part number and serial number of the suspected faulty device
- Trouble/error information
  - Trouble/symptom being experienced
  - Activities completed to confirm fault
  - Network information (What kind of network are you using?)
  - Circumstances that preceded or led up to the error
  - Message or alarms viewed
  - Steps taken to reproduce the problem
- ServPak information (if a Servpak customer):
  - ServPak account number
- Registration information
  - If the product is not registered, date and location where you purchased the product



*: Technical Support is free for the warranty period from the date of purchase.*

## Support Options

### Proxim eService Web Site Support

The Proxim eService Web site is available 7x24x365 at <http://my.proxim.com>.

On the Proxim eService Web Site, you can access the following services:

- **Product Download Page:** Provides quick links to product firmware, software, and documentation downloads.
- **Proxim TV Links:** A link to helpful video tutorials.
- **Knowledgebase:** A solution database of all the resolved problems. You can search by product, category, keywords, or phrases.
- **Live Chat:** Chat with a support technician on-line or request to call back at a later time.
- **Create a Support Request:** Create a support request with our technical support staff who will reply to you by email.
- **Case Management:** Login to check the status of your support cases, update your personal profile, or access restricted information and features.
- **Provide Feedback:** Submit a suggestion, complaint, or other feedback about the support site and our products.

## Telephone Support

Contact technical support via telephone as follows:

- **USA and Canada Customers**
  - **Phone:** +1-408-383-7700; +1-866-674-6626
  - **Business Hours:** 24x7 live response. Tier 3 support: 8 a.m. to 5 p.m. M-F PDT (UTC/GMT -7 hrs)
- **International Customers**
  - **Phone:** +1-408-383-7700; 0800-916475 (France); 8-800-100-9485 (Russia)
  - **Business Hours:** 24x7 live response. Tier 3 support: 8 a.m. to 5 p.m. M-F PDT (UTC/GMT -7 hrs)

## ServPak Support

To provide even greater investment protection, Proxim Wireless offers a cost-effective support program called ServPak. ServPak is a program of enhanced service support options that can be purchased as a bundle or individually, tailored to meet your specific needs. Whether your requirement is round the clock technical support or advance replacement service, we are confident that the level of support provided in every service in our portfolio will exceed your expectations.

All ServPak service bundles are sold as service contracts that provide coverage for specific products from 1 to 3 years. Servpak bundles are considered an upgrade to the standard product warranty and not an extension.

All Plans Include	ServPak Plus	ServPak Prime	ServPak Elite
<b>24x7 Basic Technical Support</b>	<b>Basic Advanced Replacement (Two business days/ International economy shipment service)</b>	<b>Priority Advanced Replacement (Next business day/ International priority shipment service)</b>	<b>Priority Comprehensive Advance Replacement (Next business day/ International priority shipment service)</b>
<b>8x7 Advanced Technical Support</b>		<b>24x7 Advanced Technical Support</b>	<b>24x7 Advanced Technical Support</b>
<b>Software Maintenance</b>		<b>PVES &amp; PV NMS Support</b>	<b>PVES &amp; PV NMS Support</b>
<b>Access to Knowledge Base</b>			<b>Post-Installation Optimization</b>
			<b>50% discount on Onsite Technical Support and Services</b>

## **Additional Information on ServPak Options**

### **Advanced Replacement of Hardware**

In the event of a hardware failure, our guaranteed turnaround time for return to factory repair is 30 days or less. Customers who purchase this service are guaranteed replacement of refurbished or new hardware to be shipped out within one or two business days, as applicable. Options are available for shipment services depending on the customer's support needs. Hardware is shipped on business days, Monday – Friday excluding Holidays, 8:00 AM – 3:30 PM Eastern Time.

### **Comprehensive Advanced Replacement of Hardware**

In addition to ServPak Prime options, in the event of a hardware failure, Proxim will repair or replace the failed product for any reason, other than vandalism.

### **7x24x365 Availability**

Unlimited, direct access to technical support engineers 24 hours a day, 7 days a week, 365 days a year including Holidays.

### **8x5 Availability**

Unlimited, direct access to world-class technical support engineers 8 hours a day, 5 days a week, Monday through Friday from 8:00AM - 5:00PM Pacific Standard Time.

### **Basic Technical Support**

Customers who purchase this service can be rest assured that their call will be answered by Proxim's Tier 1 technical support and a case opened immediately to document the problem and provide initial troubleshooting to identify the solution and resolve the incident in a timely manner.

### **Advanced Technical Support**

In addition to Proxim's world-class Tier 1 technical support, customers will be able to have their more complex issues escalated to our world-class Tier 3 technical support engineers. Our Tier 3 engineers will review specific configurations to troubleshoot intricate issues and will also provide helpful insights regarding Proxim's products and various tips from decades of collective experience in the wireless industry.

### **Software Maintenance**

It's important to maintain and enhance security and performance of wireless equipment and Proxim makes this easy by providing a Software Maintenance program that enables customers to access new feature and functionality rich software upgrades and updates. Customers will also have full access to Proxim's vast Knowledgebase of technical bulletins, white papers and troubleshooting documents.

### **Post-Installation Optimization**

You can consult with our technical support engineers to enhance performance and efficiency of your network. Post-installation optimization services include:

- Review frequencies to select best possible channel
- Review Modulation, Channel Bandwidth, MIMO, and WOPR settings to optimize throughput and link quality

- Review Satellite Density & TPC/ATPC settings
- Assistance with Bandwidth controls
- Assistance with QoS, RADIUS, and VLAN settings on Proxim equipment

To purchase ServPak support services, please contact your authorized Proxim distributor. To receive more information or for questions on any of the available ServPak support options, please visit our website at <http://www.proxim.com/support/servpak>, call Proxim Support (For telephone numbers, see [Telephone Support](#)) or send an email to [servpak@proxim.com](mailto:servpak@proxim.com).

## Technical Support Policy

### Technical Support for Current Products during Warranty Period

All Customers are entitled to free technical support for the Proxim products they purchase from Proxim's authorized resellers or distributors. Technical Support is defined as communication via the Proxim Support website (<http://my.proxim.com>) and/or via telephone. This technical support will be provided for free for the entire time the product is covered by a Proxim warranty. The term of Proxim's warranty is determined according to the agreement under which the product was sold and generally varies from 3 months to 2 years depending on the product. If a Customer disagrees with Proxim's determination of warranty duration, a request for review supported by a copy of all product purchase documentation may be submitted.

### Technical Support for Current Products after Warranty Period

After the warranty period, technical support on products then being sold by Proxim will be based upon one of the following three options Customers can choose:

- Customers can choose to purchase one of Proxim's ServPak extended warranty and enhanced support packages for the product
- Customers can choose to purchase one-time per-incident technical support for the product for a fee
- Customers can choose to call the reseller or distributor who sold them the product for technical support

### Tech Support on Discontinued Products

For EOL (End of Life) products no longer being sold by Proxim the following support options may be available, depending on the product:

- Fee based per-incident technical support on a per hour basis. This fee is in addition to any subsequent fees that may be charged to repair the product. Please contact Proxim Customer Service for current product support and repair pricing and availability.
- Additional support options may be available from the reseller or distributor from whom the product was purchased.

Support for discontinued products is provided on a "best effort" basis and is subject to the availability of necessary components, equipment, and other technical resources.

Note that Proxim is unable to support or warrant any equipment that has been modified, whether this modification is physical, or if third-party software codes have been loaded onto the product.

## FCC Safety & Regulatory Information

### FCC Safety Information

This equipment has been tested and found to comply with the limits for a Class B digital device, pursuant to Part 15 of the FCC (Federal Communications Commission) Rules. These limits are designed to provide reasonable protection against harmful interference in a residential installation. This equipment generates, uses and can radiate radio frequency energy and, if not installed and used in accordance with the instructions, may cause harmful interference to radio communications. However, there is no guarantee that interference will not occur in a particular installation. If this equipment does cause harmful interference to radio or television reception, which can be determined by turning the equipment off and on, the user is encouraged to try to correct the interference by one or more of the following measures:

- Reorient or relocate the receiving antenna.
- Increase the separation between the equipment and receiver.
- Connect the equipment into an outlet on a circuit different from that to which the receiver is connected.
- Consult the dealer or an experienced radio/TV technician for help.

This device complies with Part 15 of the FCC Rules. Operation is subject to the following two conditions: (1) This device may not cause harmful interference, and (2) this device must accept any interference received, including interference that may cause undesired operation.

This device and its antenna(s) must not be co-located or operating in conjunction with any other antenna or transmitter.

For product available in the USA/Canada market, only channel 1~11 can be operated. Selection of other channels is not possible.



:

**NOTE**

**THE GRANTEE IS NOT RESPONSIBLE FOR ANY CHANGES OR MODIFICATIONS NOT EXPRESSLY APPROVED BY THE PARTY RESPONSIBLE FOR COMPLIANCE. SUCH MODIFICATIONS COULD VOID THE USER'S AUTHORITY TO OPERATE THE EQUIPMENT.**



*: This equipment complies with FCC radiation exposure limits set forth for an uncontrolled environment. This equipment should be installed and operated with minimum distance of 30cm between the radiator & your body.*

### IC Safety Information

This device complies with IC (Industry Canada) licence-exempt RSS standard(s). Operation is subject to the following two conditions: (1) this device may not cause interference, and (2) this device must accept any interference, including interference that may cause undesired operation of the device.



Le présent appareil est conforme aux CNR d'Industrie Canada applicables aux appareils radio exempts de licence. L'exploitation est autorisée aux deux conditions suivantes : (1) l'appareil ne doit pas produire de brouillage, et (2) l'utilisateur de l'appareil doit accepter tout brouillage radioélectrique subi, même si le brouillage est susceptible d'en compromettre le fonctionnement.

- The device could automatically discontinue transmission in case of absence of information to transmit, or operational failure. Note that this is not intended to prohibit transmission of control or signalling information or the use of repetitive codes where required by the technology.
- The device for the band 5150-5250 MHz is only for indoor usage to reduce potential for harmful interference to co-channel mobile satellite systems.
- The maximum antenna gain permitted (for devices in the 5250-5350 MHz and 5470-5725 MHz bands) to comply with the e.i.r.p. limit; and the maximum antenna gain permitted (for devices in the 5725-5825 MHz band) to comply with the e.i.r.p. limits specified for point-to-point and non point-to-point operation as appropriate, as stated in RSS-210 Annex 9 A9.2(3).
- Users should also be cautioned to take note that high power radars are allocated as primary users (meaning they have priority) of 5250-5350 MHz and 5650-5850 MHz and these radars could cause interference and/or damage to LE-LAN devices.



:

### **NOTE**

**THE GRANTEE IS NOT RESPONSIBLE FOR ANY CHANGES OR MODIFICATIONS NOT EXPRESSLY APPROVED BY THE PARTY RESPONSIBLE FOR COMPLIANCE. SUCH MODIFICATIONS COULD VOID THE USER'S AUTHORITY TO OPERATE THE EQUIPMENT.**



:

### **IC Radiation Exposure Statement:**

**This equipment complies with IC RSS-102 radiation exposure limits set forth for an uncontrolled environment. This equipment should be installed and operated with minimum distance of 30 cm between the radiator and our body.**