

## Warning Statement

### FCC NOTICE

This device has been tested and found to comply with the limits for a Class B digital device, pursuant to Part 15 of the FCC Rules. These limits are designed to provide reasonable protection against harmful interference in a residential installation. This device generates uses and can radiate radio frequency energy and, if not installed and used in accordance with the instructions, may cause harmful interference to radio communications. However, there is no guarantee that interference will not occur in a particular installation. If this device does cause harmful interference to radio or television reception, the user is encouraged to try to correct the interference by one or more of the following measures:

- Reorient or relocate the receiving antenna.
- Connect the computer to an outlet on a circuit different from that to which the receiver is connected.
- Increase the separation between the computer and receiver.
- Consult the dealer or an experienced radio/TV technician for help.

**Caution:** Any changes or modifications not expressly approved by the grantee of this device could void the user's authority to operate the equipment.

**FCC Compliance Statement:** This device complies with Part 15 of the FCC Rules. Operation is subject to the following two conditions:

This device may not cause harmful interference, and

This device must accept any interference received, including interference that may cause undesired operation.

### RF Exposure warning

The equipment complies with FCC RF exposure limits set forth for an uncontrolled environment.

This device and its antenna(s) must not be co-located with any other transmitters except in accordance with FCC multi-transmitter product procedures.

Referring to the multi-transmitter policy, multiple-transmitter(s) and module(s) can be operated simultaneously without C2P.

For product available in the USA/Canada market, only channel 1~11 can be operated. Selection of other channels is not possible.

This device is going to be operated in 5.15~5.25GHz frequency range, it is restricted in indoor environment only.

Devices will not permit operations on channels 120-132 for 11a and 11n/a which overlap the 5600 - 5650 MHz band.

**IMPORTANT NOTE:**

This module is intended for OEM integrator. The OEM integrator is responsible for the compliance to all the rules that apply to the product into which this certified RF module is integrated.

Additional testing and certification may be necessary when multiple modules are used.

20cm minimum distance has to be able to be maintained between the antenna and the users for the host this module is integrated into. Under such configuration, the FCC radiation exposure limits set forth for an population/uncontrolled environment can be satisfied.

**USERS MANUAL OF THE END PRODUCT:**

In the users manual of the end product, the end user has to be informed to keep at least 20cm separation with the antenna while this end product is installed and operated. The end user has to be informed that the FCC radio-frequency exposure guidelines for an uncontrolled environment can be satisfied. The end user has to also be informed that any changes or modifications not expressly approved by the manufacturer could void the user's authority to operate this equipment. If the size of the end product is smaller than 8x10cm, then additional FCC part 15.19 statement is required to be available in the users manual: This device complies with Part 15 of FCC rules. Operation is subject to the following two conditions: (1) this device may not cause harmful interference and (2) this device must accept any interference received, including interference that may cause undesired operation.

**LABEL OF THE END PRODUCT:**

The final end product must be labeled in a visible area with the following " Contains TX FCC ID: HZB-XB92WLE ". If the size of the end product is larger than 8x10cm, then the following FCC part 15.19 statement has to also be available on the label: This device complies with Part 15 of FCC rules. Operation is subject to the following two conditions: (1) this device may not cause harmful

interference and (2) this device must accept any interference received, including interference that may cause undesired operation.

## **IC NOTICE**

This device complies with Industry Canada license-exempt RSS standard(s). Operation is subject to the following two conditions: (1) this device may not cause interference, and (2) this device must accept any interference, including interference that may cause undesired operation of the device.

*Le présent appareil est conforme aux CNR d'Industrie Canada applicables aux appareils radio exempts de licence. L'exploitation est autorisée aux deux conditions suivantes : (1) l'appareil ne doit pas produire de brouillage, et (2) l'utilisateur de l'appareil doit accepter tout brouillage radioélectrique subi, même si le brouillage est susceptible d'en compromettre le fonctionnement.*

For product available in the USA/Canada market, only channel 1~11 can be operated. Selection of other channels is not possible.

*Pour les produits disponibles aux États-Unis / Canada du marché, seul le canal 1 à 11 peuvent être exploités. Sélection d'autres canaux n'est pas possible.*

This device and its antenna(s) must not be co-located with any other transmitters except in accordance with IC multi-transmitter product procedures.

Referring to the multi-transmitter policy, multiple-transmitter(s) and module(s) can be operated simultaneously without reassessment permissive change.

*Cet appareil et son antenne (s) ne doit pas être co-localisés ou fonctionnement en association avec une autre antenne ou transmetteur.*

The device could automatically discontinue transmission in case of absence of information to transmit, or operational failure. Note that this is not intended to prohibit transmission of control or signaling information or the use of repetitive codes where required by the technology.

*Le dispositif pourrait automatiquement cesser d'émettre en cas d'absence d'informations à transmettre, ou une défaillance opérationnelle. Notez que ce n'est pas l'intention d'interdire la transmission des informations de contrôle ou de signalisation ou l'utilisation de codes répétitifs lorsque requis par la technologie.*

Dynamic Frequency Selection (DFS) for devices operating in the bands 5250-5350 MHz,

5470-5600 MHz and 5650-5725 MHz

*Sélection dynamique de fréquences (DFS) pour les dispositifs fonctionnant dans les bandes 5250-5350 MHz, 5470-5600 MHz et 5650-5725 MHz*

The device for the band 5150-5250 MHz is only for indoor usage to reduce potential for harmful interference to co-channel mobile satellite systems.

*les dispositifs fonctionnant dans la bande 5150-5250 MHz sont réservés uniquement pour une utilisation à l'intérieur afin de réduire les risques de brouillage préjudiciable aux systèmes de satellites mobiles utilisant les mêmes canaux.*

The maximum antenna gain permitted (for devices in the bands 5250-5350 MHz and 5470-5725 MHz) to comply with the e.i.r.p. limit.

*le gain maximal d'antenne permis pour les dispositifs utilisant les bandes 5250-5350 MHz et 5470-5725 MHz doit se conformer à la limite de p.i.r.e.;*

Users should also be advised that high-power radars are allocated as primary users (i.e. priority users) of the bands 5250-5350 MHz and 5650-5850 MHz and that these radars could cause interference and/or damage to LE-LAN devices.

*De plus, les utilisateurs devraient aussi être avisés que les utilisateurs de radars de haute puissance sont désignés utilisateurs principaux (c.-à-d., qu'ils ont la priorité) pour les bandes 5250-5350 MHz et 5650-5850 MHz et que ces radars pourraient causer du brouillage et/ou des dommages aux dispositifs LAN-EL.*

## **IMPORTANT NOTE:**

### **IC Radiation Exposure Statement:**

This equipment complies with IC RSS-102 radiation exposure limits set forth for an uncontrolled environment. This equipment should be installed and operated with minimum distance 20cm between the radiator & your body.

*Cet équipement est conforme aux limites d'exposition aux rayonnements IC établies pour un environnement non contrôlé. Cet équipement doit être installé et utilisé avec un minimum de 20 cm de distance entre la source de rayonnement et votre corps.*

**IMPORTANT NOTE:**

This module is intended for OEM integrator. The OEM integrator is still responsible for the IC compliance requirement of the end product, which integrates this module.

**USERS MANUAL OF THE END PRODUCT:**

In the users manual of the end product, the end user has to be informed to keep at least 20cm separation with the antenna while this end product is installed and operated. The end user has to be informed that the IC radio-frequency exposure guidelines for an uncontrolled environment can be satisfied. The end user has to also be informed that any changes or modifications not expressly approved by the manufacturer could void the user's authority to operate this equipment. IC statement is required to be available in the users manual: This Class B digital apparatus complies with Canadian ICES-003. Operation is subject to the following two conditions: (1) this device may not cause harmful interference and (2) this device must accept any interference received, including interference that may cause undesired operation.

**LABEL OF THE END PRODUCT:**

The final end product must be labeled in a visible area with the following " Contains TX IC : 1856A-XB92WLE ".

This device complies with the Electromagnetic Compatibility Directive (89/336/EEC) issued by the Commission of the European Community. Compliance with this directive implies conformity to the following European Norms (in brackets are the equivalent international standards.)

**Electromagnetic Interference (Conduction and Radiation):** EN 55022 (CISPR 22)

**Electromagnetic Immunity:** EN 55024 (IEC61000-4-2, 3, 4, 5, 6, 8, 11)

**Low Voltage Directive:** EN 60 950: 1992+A1: 1993+A2: 1993+A3: 1995+A4: 1996+A11: 1997.

CE Mark: following the provisions of the EC directive.

The wireless card in this product complies with the R&TTE Directive (1999/5/EC)

issued by the Commission of the European Community. Compliance with this directive implies conformity to

the following:

EMC Standards: FCC: 47 CFR Part 15, Subpart B, 47 CFR Part 15, Subpart C (Section 15.247); CE:

EN 300 328-2, EN 300 826 (EN 301 489-17)

CE Mark: following the provisions of the EC directive.

Manual Version: 2.08c (June 2010)

This manual is written based on Firmware version 2.00

# Overview the Product

## Introduction

The high-performance Wireless Network Access Point (AP) is designed for enterprise and public access applications. Embedded with the Atheros chipset, it boasts network robustness, stability and wider network coverage. Based on 802.11n (Draft 2.0), the access point supports high-speed data transmission of up to 300Mbps.

The access point is capable of operating in different modes, which makes it suitable for a wide variety of wireless applications, including long-distance deployments.

Designed with dual polarization high gain antenna it offers a compact, rugged design for outdoor installation and excellent performance.

Moreover, its integrated Power over Ethernet (PoE) allows the access point to be used in areas where power outlets are not readily available.

To protect your security and privacy, the access point is armed with many enhanced and latest wireless security features such as IEEE 802.11i standards, MAC Address Filtering, IEEE 802.1x Authentication and 64/128-bit WEP (Wired Equivalent Privacy) to ensure privacy for the heterogeneous mix of users within the same wireless network.

The access point also incorporates a unique set of advanced features such as: Virtual AP to deliver multiple services; Long-Range parameter fine-tuning which provide the access point with the ability to auto-calculate parameters such as slot time, ACK time-out and CTS time-out to achieve a longer range.

## **Features and Benefits**

### **Point-to-Point & Point-to-MultiPoint Support**

Point-to-Point and Point-to-MultiPoint communication between different buildings enables you to bridge wireless clients that are kilometres apart while unifying the networks.

### **Virtual AP (Multiple SSID)**

Virtual AP implements mSSID (Multi-SSID) This allows a single wireless card to be set up with multiple virtual AP connections with different SSIDs or BSSID (Basic Service Set Identifier) and security modes.

### **Highly Secured Wireless Network**

The access point supports the highest available wireless security standard: IEEE802.11i compliant.

The access point also supports IEEE 802.1x for secure and centralized user-based authentication.

Wireless clients are thus required to authenticate through highly secure methods like EAP-TTLS and EAP-PEAP, in order to obtain access to the network.

### **uConfig Utility**

The exclusive uConfig utility allows users to access the user-friendly Web configuration interface of the access point without having to change the TCP/IP setup of the workstation.

### **HTTPS**

The access point supports HTTPS (SSL) in addition to the standard HTTP. HTTPS (SSL) features additional authentication and encryption for secure communication.

### **Telnet**

Telnet allows a computer to remotely connect to the access point CLI (Command Line Interface) for control and monitoring.

SSH SSH (Secure Shell Host) establishes a secure host connection to the access point CLI for control and monitoring.



## Operation Modes and Connection Examples

### Access Point and Access Point WDS Mode

The Access Point Mode is the default mode of the device. It enables the bridging of wireless clients to wired network infrastructure and enables transparent access and communication with each other.

The illustration below shows a typical resources sharing application example using this device. The wireless users are able to access the file server connected to the switch, through the access point in Access Point Mode.

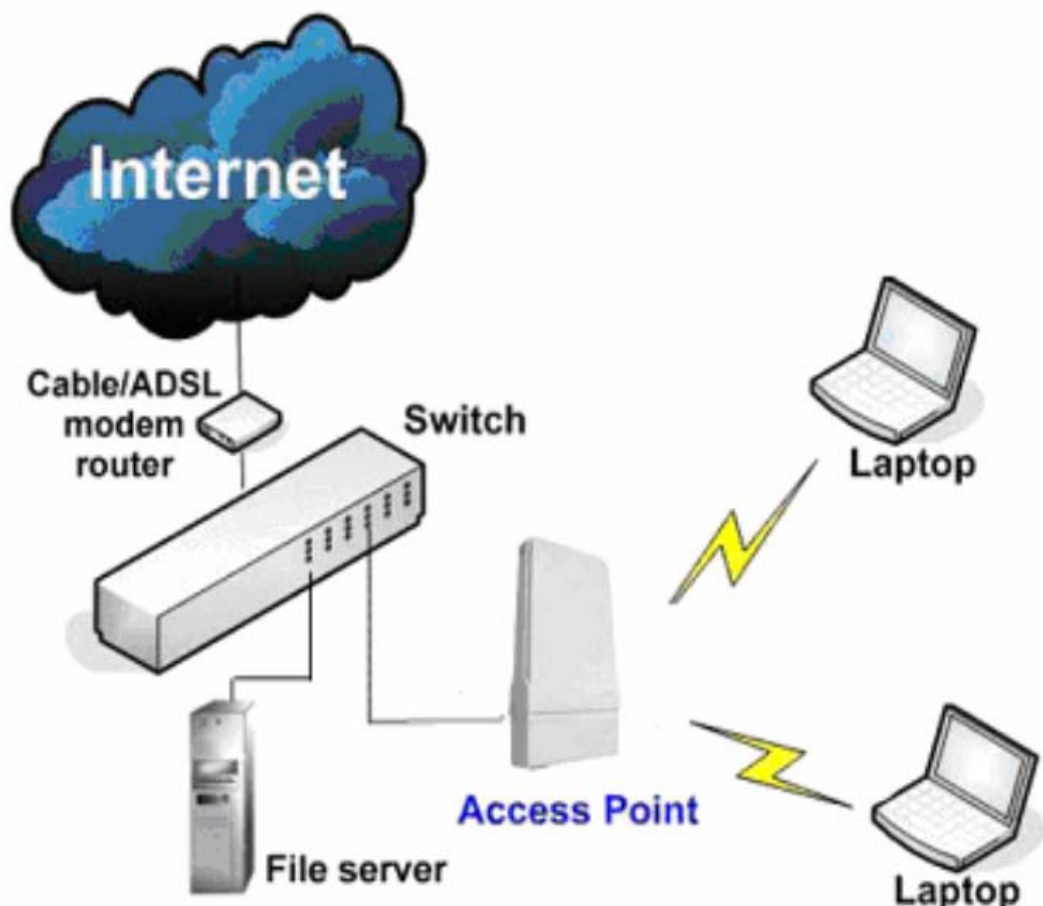

### Access Point WDS Mode

This mode is generally used for point-to-point or point-to-multi-point connections. It is mainly used with Station WDS to build the point and multi-point connections.

## Station Mode

In **Station** mode the device acts as a wireless client.

When connected to an access point, it creates a network link between the Ethernet network connected at this client device, and the wireless Ethernet network connected at the access point.

In this example the workgroup PCs on the ethernet network connected to the Station device can access the printer across the wireless connection to the access point where the printer is connected.

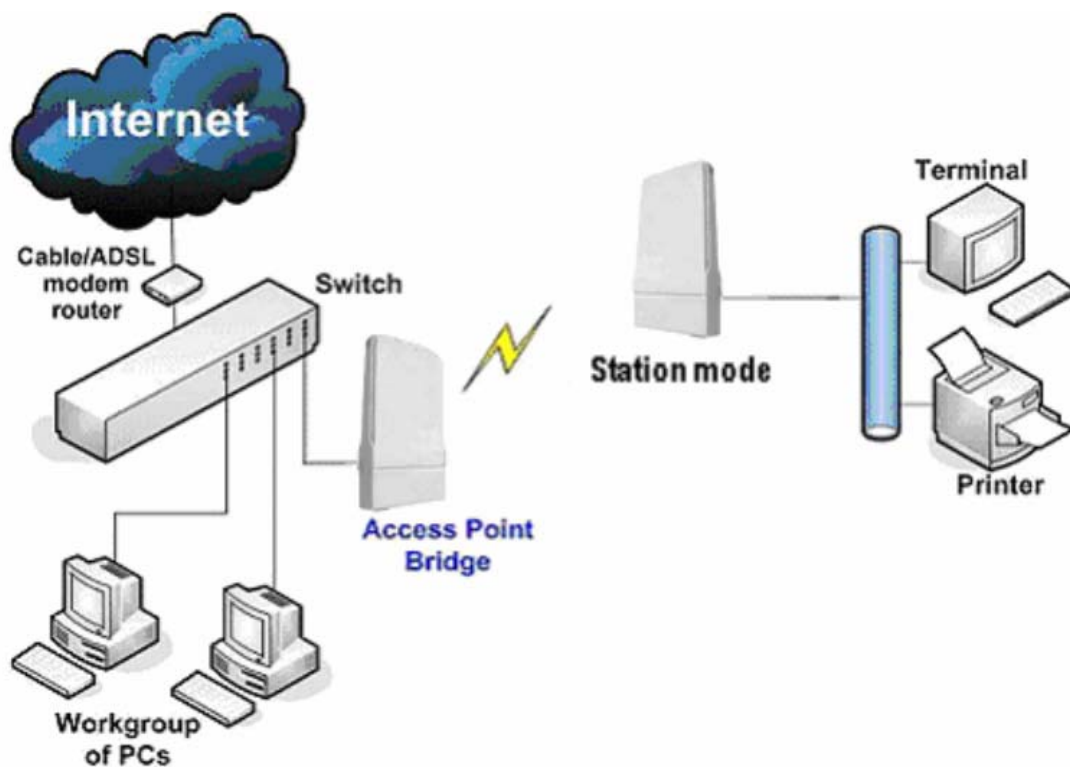

## Station WDS Mode

Station WDS mode is similar to Station mode. The difference is Station WDS must connect to access point configured to Access Point WDS (or RootAP) mode.

Station WDS is mainly use for point-to-point connection between 2 buildings or locations as far as several kilometer away.

Point-to-Point	Point-to-MultiPoint
An access point setup as Access Point WDS (or RootAP) and other as Station WDS (Transparent Client).	An access point setup as Access Point WDS (or RootAP) and several other devices as Station WDS (or Transparent Client).

This mode is generally used for outdoor connections over long distances, or for indoor connections between local networks.

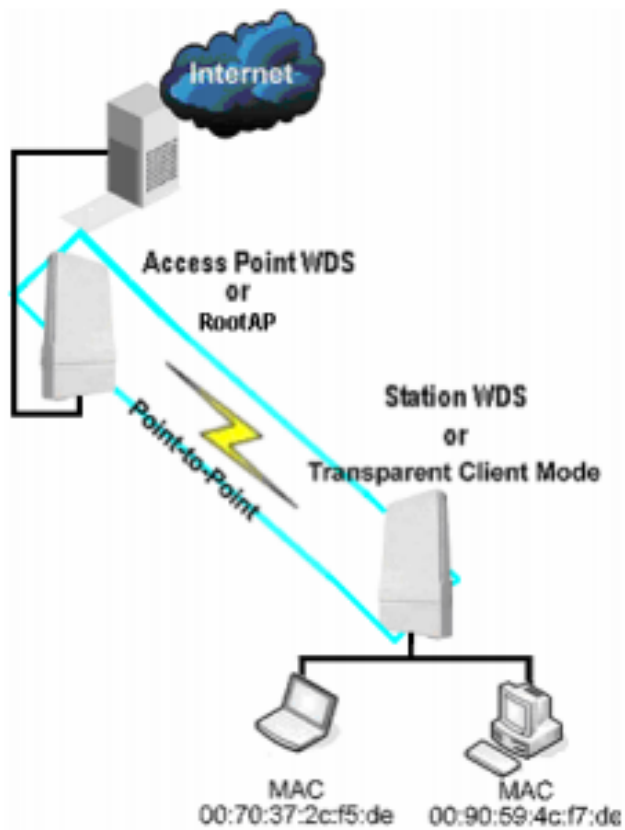

## Router Mode

In Router Mode, the device also operates as a router.

Either the wireless or Ethernet can be setup as WAN connection to a broadband modem. Wireless as WAN is known as **Station + Router mode** (or **Wireless Routing Client**

mode) and Ethernet as WAN is known as **AP + Router mode**(or **Gateway** mode). Device supports several types of broadband connections Static IP, Dynamic IP and PPPoE. For setup details refer to the respective section.

The illustration below shows the Ethernet port is setup as the WAN port and the wireless connection as the LAN.

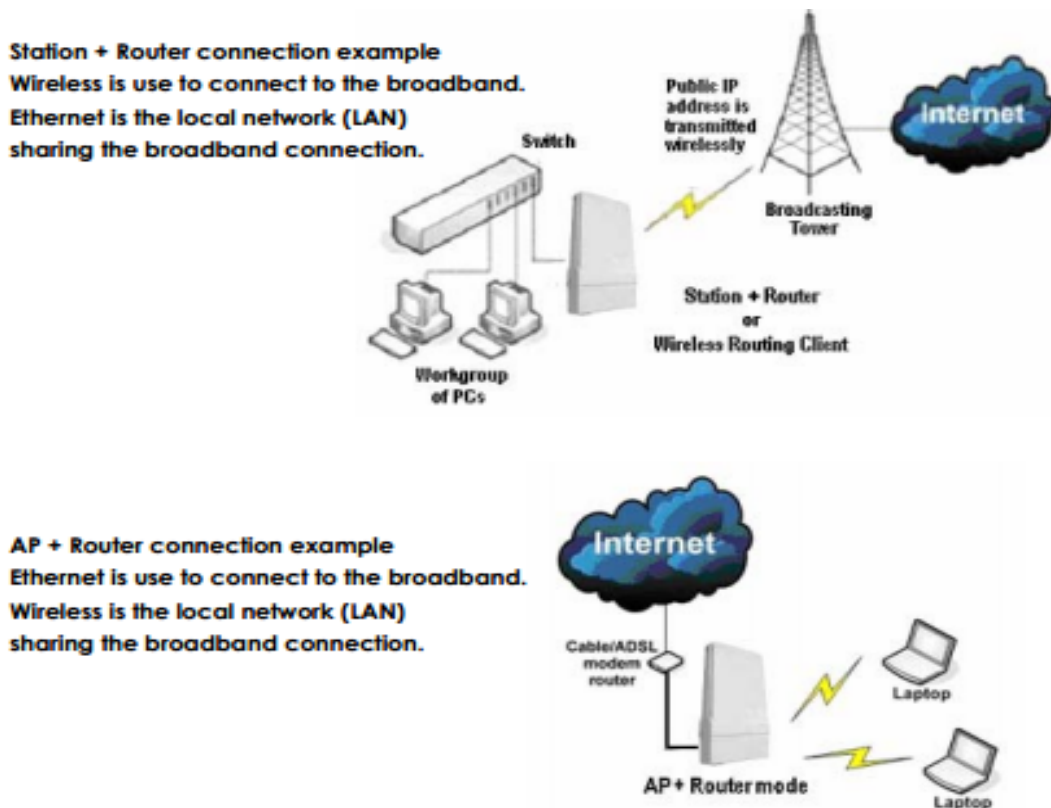

Broadband Internet Access Type:

### Static IP Address

Use Static IP Address you have subscribed a fixed IP or range IP addresses from your ISP.

### Dynamic IP Address

With Dynamic IP Address the device automatically request IP address from modem or ISP.

### PPP over Ethernet (PPPoE)

When using ADSL services provided byyour ISP support PPPoE connection.

## Repeater WDS Mode

Repeater WDS Mode is mainly to extend the wireless range and coverage of the wireless network allowing access and communications over places generally difficult for wireless clients to connect to the network.

In Repeater mode, the access point acts as a relay for network signals on the network by regenerating the signals it receives, and retransmitting them to main network infrastructure.

Detailed information on the Repeater mode is available in the Repeater Setup section.

**\*\* Note: Repeater WDS requires the access point to be setup in RootAP or Access Point WDS mode to work.**

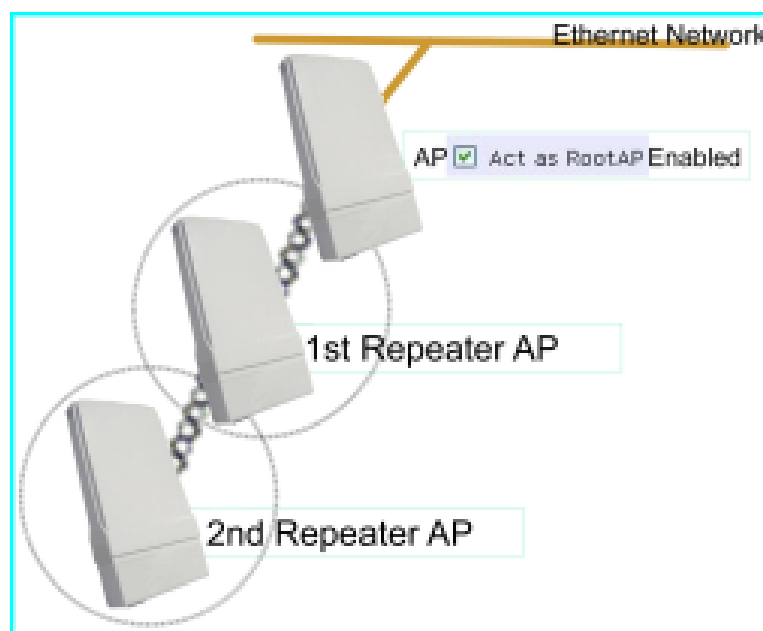

## Install the Hardware

This section will show you how to install the hardware of the access point.

- **Antenna Alignment**

The antenna alignment of the access point must first be considered to ensure that the signal is strong.

- **Installation Direction**

After considering the antenna alignment, the direction in which the access point is facing must be considered to ensure that the signal is actually being directed to the receiving end.

- **Setting Up**

Lastly, after making these considerations and confirming the final position and facing direction of the access point, follow the instructions to physically set up and complete the installation of the access point

## **Setup Requirements**

- CAT5/5e Networking Cable.
- At least 1 computer installed with a web browser and a wired or wireless network interface adapter.
- All network nodes installed with TCP/IP and properly configured IP address parameters.

## **Mount the Unit on a Pole**

Access point is designed to mount to a pole. The mounting method will be described as shown below.

Note the following guidelines for choosing the best location for your wireless AP:

- Place the AP as close as possible to the area where users will require access to the WLAN.
- Choose an elevated location where trees, buildings and large steel structures will not obstruct the antenna signals and which offers maximum line-of-sight propagation with the users.
- Select an appropriate antenna to improve range and/or coverage and the access point also lets you fine-tune parameters such as the transmit power to achieve the best results

## Prepare Unit to mount to a pole

### Step 1

Unpack the 2 cable ties from the box.



### Step 2

Loop each cable tie through the mounting bracket hole at the top and bottom. Wrap them round the pole and tighten the cable ties to secure the unit to the pole.



### Step 3

Connect one end of an RJ45 Ethernet cable to the LAN OUT port of the Injector and the other end to LAN of the access point.

Maximum length of the RJ45 Category 5 cable is 100 meters\*.

\* Up to 200mW radio. For higher power radio need upgrade to higher rating power adapter.

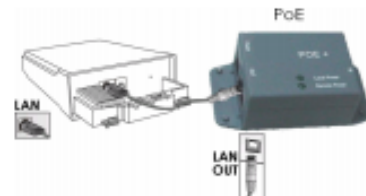



#### Step 4

Connect the RJ45 Ethernet cable attached to the PoE Injector to a network device, such as to a switch or to the PC you will use to configure the access point.

PoE power input: Passive PoE (range 12V – 24V DC)



#### Step 5

Connect the power adapter in the PoE kit to the main electrical supply and the power plug into the socket of the injector.

Now, turn on your power supply. Notice that the **POWER** LED has lighted up. This indicates that the access point is receiving power through the PoE Injector and that connection between the access point and your network has been established.

Note:

Please use the power adapter in the PoE kit. Using a power adapter with a different voltage rating will damage this product.



## Configure the IP Address

After setting up the hardware you need to assign an IP address to your PC so that it is in the same subnet as the access point.

### For Windows 95/98/98SE/ME/NT

#### Step 1:

From your desktop, right-click the **Network Neighborhood** icon and select **Properties**.

#### Step 2:

Select the network adapter that you are using, then right-click and select **Properties**.

#### Step 3:

Highlight **TCP/IP** and click on the **Properties** button.



#### Step 4:

Select the **Specify an IP address** radio button.

Set the IP address to 192.168.168.X and subnet mask to 255.255.255.0, where X can be any number from 2 to 254.



### Step 5:

To verify that the IP address has been correctly assigned to your PC, go to the **Start** menu, select **Run**, and enter the command: `wiipcfg`.

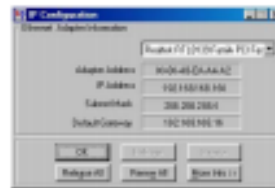

Select the Ethernet adapter from the drop-down list and click **OK**.

PC is now setup with proper IP address to communicate with the access point.

## For Windows XP/2000

### Step 1:

Go to your desktop, right-click on the **My Network Places** icon and select **Properties**.

### Step 2:

Right-click the network adapter icon and select **Properties**.



### Step 3:

Highlight **Internet Protocol (TCP/IP)** and click on the **Properties** button.

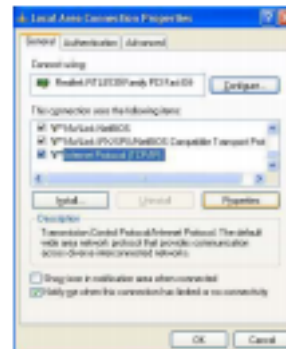

### Step 4:

Select the **Use the following IP address** radio button.

Set the IP address to 192.168.168.X and subnet mask to 255.255.255.0, where X can be any number from 2 to 254.



**Step 5:**

Click on the **OK** button to close all windows.

**Step 6:**

To verify that the IP address has been correctly assigned to your PC, go to the **Start** menu, **Accessories**, select **Command Prompt**, and type the command: `ipconfig/all`

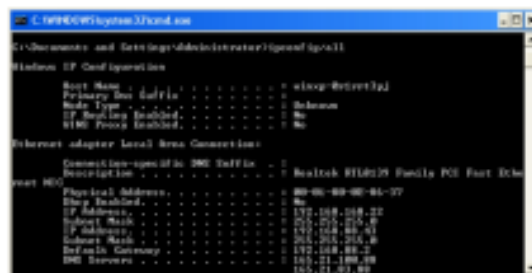

```
C:\Documents and Settings\shelton\My Recent Places>ipconfig/all

Windows IP Configuration

Host Name . . . . . : eltop-Win7-10
Primary Dns Suffix . . . . . : 
Node Type . . . . . : Hybrid
IP Filtering Enabled . . . . . : Disabled
WINS Proxy Enabled . . . . . : No

Ethernet adapter Local Area Connection 2:

   Connection-specific DNS Suffix . . . : 
   Description . . . . . : Realtek RTL8102B Family PCI Fast Eth
   Physical Address. . . . . : 80-00-00-00-00-00
   Dhcp Enabled. . . . . : No
   IP Address . . . . . : 192.168.0.22
   Subnet Mask . . . . . : 255.255.255.0
   Default Gateway . . . . . : 192.168.0.1
   DNS Servers . . . . . : 192.168.0.1
   NetBIOS over LLMNR . . . . . : Enabled
```

PC is now setup with a proper IP address to communicate with the access point.