

The screenshot shows a configuration window titled "Teklogix 9150: Host Table Entry for Host2". It contains two input fields: "Name:" with the value "Host2" and "IP Address:" with the value "127.0.0.1". At the bottom, there are three buttons: "OK", "Cancel", and "Delete".

Name

This is the designated name of the host.



Note: *The name must not contain space characters.*

IP Address

This is the assigned IP address for the host.

Host Table Entries

The screenshot shows the "Host Table:" configuration section. It includes a "Host Table:" label, a "[#] Add Entry" dropdown menu, and a "Configure" button. Below this, there are three rows of configuration options: "Host Table Entries:" with a "Never Expire" dropdown, "Host Table Entry Maximum Age [seconds]" with a text input field, and a "Boots:" label. A dropdown menu is open over the "Host Table Entry Maximum Age" field, showing options: "Never Expire", "Are Not Cached", "Never Expire", and "Expire".

This parameter allows you to determine the behaviour of the host name cache. The allowable settings are: **Expire**, **Are Not Cached**, and **Never Expire**. If **Expire** is selected, a timeout length determines how long the cached entries will remain in the table (see parameter, “Host Table Entry Maximum Age”, below).

The default setting is **Never Expire**.

Host Table Entry Maximum Age (seconds)

This parameter allows you to set the expiry time limit (in seconds) for the host name cache when the *Host Table Entries* parameter is set to **Expire**.

The minimum allowable value is **30**. The default value is **600**.

3.4.6.3 Network Interface Configuration Protocol

| Network Interface Configuration Protocol: | |
|---|-----------------------|
| Network Interface Configuration Protocol: | None |
| DHCP Lease Time: [days] | 0 |
| Default Gateway Address: | 10.128.0.1 10.128.0.1 |

The 9150 has designated default IP addresses for itself and the network Gateway. Alternatively, the IP address of the 9150 can be assigned by either a DHCP Server or BOOTP Server, if one is appropriately configured on the network.

If either the **DHCP** or **BOOTP** option is chosen from the *Network Interface Configuration Protocol* drop-down list, the 9150 will broadcast a request to the appropriate server, as described in the following sections.

The default setting is **None**.



Important: *Once the 9150 is configured and rebooted the first time, the Network Interface Configuration Protocol parameter should be disabled (set to None), unless the 9150 obtains its IP address from a DHCP or bootp server, or the system administrator intends to update the software through bootp.*

| Network Interface Configuration Protocol: | |
|---|----------------|
| Network Interface Configuration Protocol: | None |
| DHCP Lease Time: [days] | None |
| Default Gateway Address: | DHCP-Ethernet |
| | BOOTP-Ethernet |

DHCP

The **D**ynamic **H**ost **C**onfiguration **P**rotocol provides a mechanism for allocating IP addresses dynamically so that addresses can be reused when hosts no longer require them, and also ensures that a particular address is not duplicated. The 9150 can obtain the following parameters from an appropriately configured DHCP Server: IP address, subnet mask, and IP address lease time (see *DHCP Lease Time* on page 53). The DNS Domain Name/Server IP addresses (see page 54) and SNTP Server IP address (see page 47) will also be requested from the DHCP Server.

Select **DHCP** for the 9150 to automatically broadcast a request for DHCP-configured addresses to all hosts on the local **Ethernet** network.

BOOTP

The primary purpose of the Bootstrap Protocol (BOOTP) is to assign a designated IP address to the appropriate 9150 on the network, and to update the 9150 software.

When the *BOOTP* option is selected from the *Network Interface Configuration Protocol* drop-down list, the 9150 automatically broadcasts a request for IP address, subnet mask, and flash image file name, to all hosts on the local **Ethernet** network, including the Wireless Distribution System (WDS) links.

BOOTP Servers search the *bootptab* files for a hardware address match for the 9150 that initiated the request for address. (Bootptab files list each hardware address with a corresponding IP address, and the flash image file.) The host with a matching hardware address in its bootp table replies to the request, sending the appropriate IP address and, if needed, the image file to the 9150.

Software Upgrade Using TFTP

The 9150 software may be upgraded by using a TFTP server instead of BOOTP. Contact the TFTP server and download the new image file by connecting the 9150 to a PC console (for details refer to page29) and entering the following command line:

```
>net tftp <servername><imagefile>
```

The image file will be loaded after the 9150 is rebooted.



Note: *This command is available for all version C releases of software, and for version B55. Do not use if B52 is the current version of software.*

DHCP Lease Time

This parameter defines the length of time (in days) that the 9150 is requesting for the lease on its IP address and subnet mask. The default setting is **0** (zero), which requests the maximum lease time configured at the DHCP Server.

Default Gateway Address

The *Default Gateway Address* creates an identifiable communication link between the 9150 and a network other than the one to which the 9150 is directly wired. The Gateway Address shown in the read-only field is the address currently assigned by the network administrator. The text box allows you to change the value of the address.

The acceptable values for the Default Gateway IP address range from **0.0.0.0** to **239.255.255.255**.



Note: *Setting the Gateway IP Address to **0.0.0.0** disables this feature. A communication link will not exist between sub-networks.*

3.4.6.4 DNS

Domain Name System allows users to locate destinations on the TCP/IP network by domain (host) name. The DNS server maintains a database of host names and their corresponding IP addresses. For example, if the server was presented with the name “www.teklogix.com”, it would return the IP address: “207.219.2.3”.

| DNS: | |
|---|--|
| DNS Resolver Enabled: | <input type="checkbox"/> |
| DNS Default Domain: | <input type="text" value="default.com"/> |
| DNS Name Server 1: | <input type="text" value="0.0.0.0"/> |
| DNS Name Server 2: | <input type="text" value="0.0.0.0"/> |
| <input type="button" value="OK"/> <input type="button" value="Cancel"/> | |

DNS Resolver Enabled

When this parameter is **enabled** (✓), the 9150 will use the DNS Name Server identified by the IP address entered in the *DNS Name Server* parameter.

DNS Default Domain

This is the default domain name for this 9150.

DNS Name Server 1

This is the IP address of the first designated DNS Name Server. The DNS Resolver will first contact this server to resolve a name query. If the query isn't resolved, the DNS Resolver will then contact the second DNS Name Server.

DNS Name Server 2

This is the IP address of the second designated DNS Name Server.

3.4.7 Serial Ports Parameters

These parameters allow you to set the baud rates for the console port and the serial port. The Serial Ports Parameters “Configure” page, is entered from the *Configuration Main Menu* page.

Teklogix 9150: Serial Ports Parameters

Console Port:

Baudrate: 19200

Serial Port:

Baudrate: 9600

OK Cancel

3.4.7.1 Console Port

Baudrate: The default baud rate for the console port is **19.2kb/s**.

Teklogix 9150: Serial Ports Parameters

Console Port:

Baudrate: 19200

Serial Port:

Baudrate: 2400, 4800, 9600, 19200, 38400

OK Cancel

3.4.7.2 Serial Port

Baudrate: The default baud rate for the serial port is **19.2kb/s**.

Teklogix 9150: Serial Ports Parameters

Console Port:

Baudrate: 19200

Serial Port:

Baudrate: 2400, 4800, 9600, 19200, 38400

OK Cancel

3.5 Access Point/Base Station/Mini-Controller Menus

The 9150 is capable of operating as a transparent bridge (access point) between the wireless and wired networks, and also as a mini-controller or base station. For these operations, the parameters in these pages must be set appropriately. For detailed information on the sub-menus and to set up the 9150 as a base station, see Chapter 5: “Base Station Configuration”. To configure an access point device, see Chapter 4: “Access Point Configuration”. To configure the 9150 as a mini-controller, see Chapter 6: “Mini-Controller Configuration”.

| Teklogix 9150: Configuration Main Menu | |
|--|---|
| General Configuration: | |
| Interfaces: | [1] 10BaseT Ethernet <input type="button" value="Configure"/> |
| Users: | [1] user <input type="button" value="Configure"/> |
| SNMP: | <input type="button" value="Configure"/> |
| Redundancy: | <input type="button" value="Configure"/> |
| SNTP: | <input type="button" value="Configure"/> |
| TCP/IP Parameters: | <input type="button" value="Configure"/> |
| Serial Ports Parameters: | <input type="button" value="Configure"/> |
| Access Point Configuration: | |
| MAC Bridge Parameters: | <input type="button" value="Configure"/> |
| Mobility Configuration: | <input type="button" value="Configure"/> |
| Mobile IP Parameters: | <input type="button" value="Configure"/> |
| Base Station Configuration: | |
| Base Stations: | [#] Create New <input type="button" value="Configure"/> |
| RRM Groups: | [#] Create New <input type="button" value="Configure"/> |
| Radio Link Features: | <input type="button" value="Configure"/> |
| Mini-Controller Configuration: | |
| Hosts: | [1] Host 5250 <input type="button" value="Configure"/> |
| 802.IQ v2 Features: | <input type="button" value="Configure"/> |
| Miscellaneous Commands: | |
| <input type="button" value="System Info"/> | <input type="button" value="Reboot Unit"/> |

3.6 Miscellaneous Commands Menu Options

There are two miscellaneous commands: *System Info* and *Reboot Unit*.

| Teklogix 9150: Configuration Main Menu | | |
|--|----------------------|-----------|
| General Configuration: | | |
| Interfaces: | [1] 10BaseT Ethernet | Configure |
| Users: | [1] user | Configure |
| SNMP: | | Configure |
| Redundancy: | | Configure |
| SNTP: | | Configure |
| TCP/IP Parameters: | | Configure |
| Serial Ports Parameters: | | Configure |
| Access Point Configuration: | | |
| MAC Bridge Parameters: | | Configure |
| Mobility Configuration: | | Configure |
| Mobile IP Parameters: | | Configure |
| Base Station Configuration: | | |
| Base Stations: | [#] Create New | Configure |
| RRM Groups: | [#] Create New | Configure |
| Radio Link Features: | | Configure |
| Mini-Controller Configuration: | | |
| Hosts: | [1] Host 5250 | Configure |
| 802.IQ v2 Features: | | Configure |
| Miscellaneous Commands: | | |
| System Info | Reboot Unit | |

3.6.1 System Info

The System Information, hardware and software, for the 9150 Wireless Gateway unit is detected automatically and summarized in this page. The screen is shown on page 58.

Teklogix 9150: System Information

| | |
|----------------------------|-----------------------------------|
| Device Model: | Teklogix 9150E |
| Unit Serial Number: | |
| Software Version: | D0600 |
| Boot Code Version: | D059Q |
| System IP Address: | 10.128.10.119 |
| Ethernet Hardware Address: | 00:c0:af:00:15:ba |
| Flash Size: | 2097152 bytes. |
| SRAM Size: | 16777216 bytes. |
| PC Card Slot A: | IEEE 802.11 DS [FCC-USA (0x10)] |
| PC Card Slot B: | TekLAN Card |
| Emulations: | enable |

OK

3.6.2 Reboot Unit

This option opens a dialog box which allows you to remotely “warm” reboot the 9150.

Teklogix 9150: Reboot Unit?

Really reboot the 9150?

OK

Cancel

If the **OK** button is chosen, the 9150 will be rebooted, the LEDs will turn off momentarily, and the following message will be received:

Teklogix 9150: Rebooting...

The 9150 has been rebooted. After a few moments, it should be back on-line.

OK



Important: *If changing radio types in the 9150, and therefore changing the **Radio Type** parameter (see page 103), the unit must be powered OFF and ON again (“cold” rebooted). Rebooting with the **Reboot Unit** option will not implement the radio parameter change.*

ACCESS POINT CONFIGURATION

4

| | |
|---|----|
| 4.1 Overview | 61 |
| 4.2 General Configuration Menu: Interfaces. | 62 |
| 4.2.1 IEEE 802.11 Direct Sequence Radio Parameters Menu | 62 |
| 4.2.1.1 802.IQ Version 1 Configuration Menu | 64 |
| 4.2.1.2 802.IQ v1/v2 Common Features | 65 |
| 4.2.1.3 802.IQ v1 Configuration Submenu | 66 |
| 4.2.1.4 802.11 Radio Information | 68 |
| 4.2.1.5 Basic Service Set (BSS) Configuration | 71 |
| 4.2.1.6 Wireless Distribution System (WDS) Configuration . 72 | |
| 4.3 Access Point Configuration Menu Options | 75 |
| 4.4 MAC Bridge Parameters | 75 |
| 4.4.1 General Configuration | 77 |
| 4.4.1.1 Bridge Spanning Tree Algorithm | 79 |
| 4.4.2 Address Filters: MAC Address | 81 |
| 4.4.3 Protocol Filters. | 83 |
| 4.4.3.1 Ethernet II Filters | 86 |
| 4.4.3.2 LLC Filters | 87 |
| 4.4.3.3 SNAP Filters. | 88 |
| 4.4.3.4 Storm Detection | 89 |
| 4.5 Mobility Configuration | 90 |
| 4.5.1 IAPP Parameters | 91 |
| 4.6 Mobile IP Parameters | 92 |
| 4.6.1 Mobile IP Configuration | 93 |
| 4.6.1.1 Mobile Agent Parameters | 93 |
| 4.6.1.2 Mobile Node Parameters | 94 |

| | |
|---|-----|
| 4.6.1.3 Supported Features. | .95 |
| 4.6.1.4 Gratuitous ARP Configuration. | .95 |
| 4.6.1.5 Security Configuration. | .96 |

4.1 Overview

The 9150 can operate as an access point device between IEEE 802.11b wireless and wired networks. Using IEEE 802.11b protocol, the 9150 provides a transparent bridge between Teklogix or client terminals and a network controller or host. For an overview of IEEE 802.11b, please refer to “IEEE 802.11b Protocol” on page 8. For operation as an access point, the parameters in the following pages must be set appropriately.



Note: The 9150 main parameters should first be set up as described in Chapter 3: “9150 Main Configuration”.

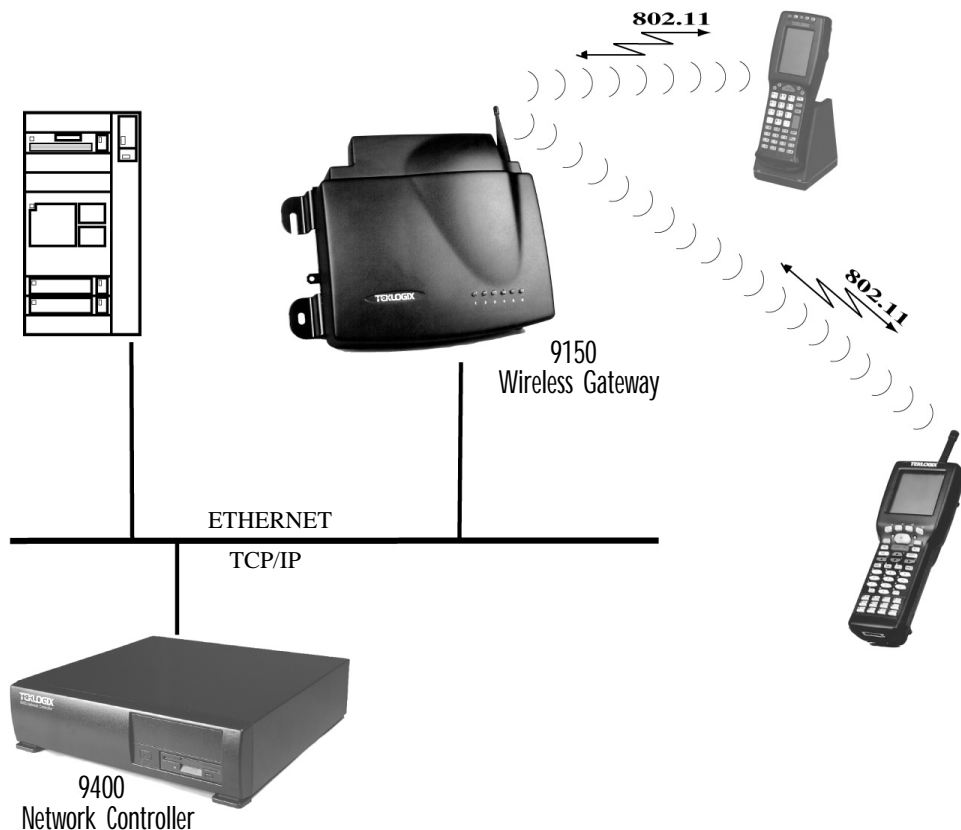
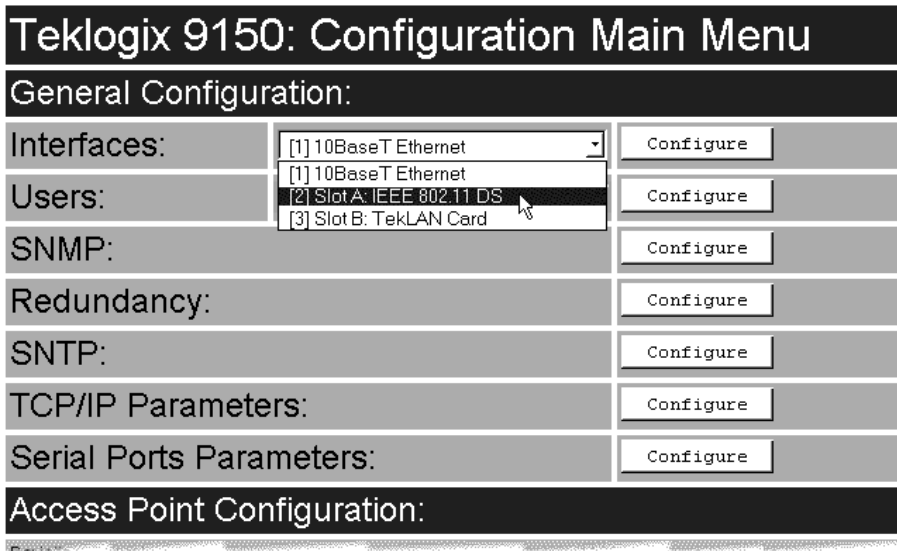

Figure 4.1 9150 Access Point Configuration

4.2 General Configuration Menu: Interfaces

The pull-down menu shown for the *Interfaces* option indicates which interfaces have been detected in use by the 9150, including any 802.11 PCMCIA radio:

- IEEE 802.11 DS: USI WaveLAN IEEE 802.11 DSSS 2.4 GHz.



Selecting *IEEE 802.11 DS* radio type from the drop-down list and entering “Configure” will open the radio parameters page for that radio.

4.2.1 IEEE 802.11 Direct Sequence Radio Parameters Menu

When the USI WaveLAN IEEE 802.11 DSSS 2.4 GHz PCMCIA card is installed in the 9150, the *IEEE 802.11 Direct Sequence Radio Parameter* sub-menu shown on the next page is opened from the Interfaces main menu.

| Teklogix 9150: Slot A - IEEE 802.11 Direct Sequence Radio Parameters | |
|---|-------------------------------------|
| 802.IQ version 1 Configuration: | |
| 802.IQ v1: | Configure |
| 802.11 Radio Information: | |
| Physical Address: | 00:60:1d:04:b8:c8 |
| AP Radio Name: | tkx9150 |
| Regulatory Domain: | FCC-USA (0x10) |
| Fixed Multicast Rate: | Auto |
| WEP Implemented on the card: | NO |
| WEP Enable: | <input type="checkbox"/> |
| HIDE WEP keys: | <input type="checkbox"/> |
| WEP Tx Key: | 1 |
| WEP Encryption Key 1: | |
| WEP Encryption Key 2: | |
| WEP Encryption Key 3: | |
| WEP Encryption Key 4: | |
| Basic Service Set (BSS) Configuration: | |
| Enabled: | <input checked="" type="checkbox"/> |
| ESSID: | TEKLOGIX |
| Allow Broadcast ESSID: | <input type="checkbox"/> |
| Channel: | 10 |
| Data Rate: | Auto |
| Wireless Distribution System (WDS) Configuration: | |
| Enabled | MAC Address of remote AP |
| <input type="checkbox"/> | 00:00:00:00:00:00 |
| <input type="checkbox"/> | 00:00:00:00:00:00 |
| <input type="checkbox"/> | 00:00:00:00:00:00 |
| <input type="checkbox"/> | 00:00:00:00:00:00 |
| <input type="checkbox"/> | 00:00:00:00:00:00 |
| <input type="checkbox"/> | 00:00:00:00:00:00 |
| <input type="button" value="OK"/> <input type="button" value="Cancel"/> | |

4.2.1.1 802.IQ Version 1 Configuration Menu

This parameter accesses the 802.IQv1 sub-menu that enables the Psion Teklogix proprietary 802.11b enhanced protocol, as described in “802.IQ v1 Sub-Menu”, below, and in “Psion Teklogix’ 802.IQ Protocol” on page 9. For information on 802.IQv2, please refer to “802.IQ Version 2 Configuration” on page 192.

802.IQ v1 Sub-Menu

802.IQ is a Psion Teklogix proprietary optimized protocol that enables terminals to operate on a wireless LAN in a network that supports both TCP/IP and 802.IQ protocol simultaneously.

802.IQv1 protocol is a wireless LAN protocol that provides greater performance in an 802.11b wireless network than is possible with TCP/IP.

The 9150 bridges the 802.IQv1 wireless and TCP/IP wired networks. A terminal can communicate with the 9150 access point using either TCP/IP or 802.IQv1 protocol.



Important: *802.IQ should only be enabled on wired 9150s.*

Do not configure 802.IQ on wired 9150s bridging networks, since 802.IQ beacons would be sent through the WDS link from one network to the other (see “Wireless Distribution System (WDS) Configuration” on page 72).

The 802.IQv1 page is entered from the 802.IQ version 1 Configuration menu on the IEEE 802.11 Direct Sequence Radio Parameters page.

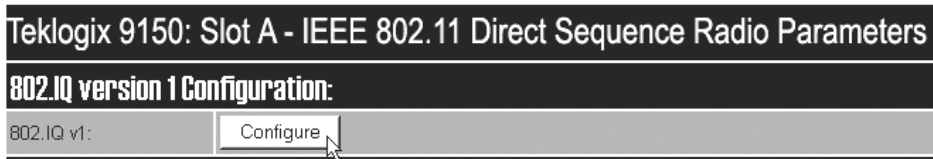

| Teklogix 9150: IEEE 802.11 DS Slot A - 802.IQ Parameters | |
|--|---------------------------------------|
| 802.IQ v1/v2 Common Features: | |
| Auto Startup: | <input type="checkbox"/> |
| Beacon Period: | <input type="text" value="2"/> |
| Terminal Offline Timeout: | <input type="text" value="5"/> |
| 802.IQ v1 Configuration: | |
| Enabled: | <input type="checkbox"/> |
| Initial RTT: | <input type="text" value="1000"/> |
| Protocol Type ID: | <input type="text" value="2457"/> |
| Forward 802.IQ Packets Only: | <input type="checkbox"/> |
| Give Higher Priority To 802.IQ Data: | <input checked="" type="checkbox"/> |
| <input type="button" value="OK"/> | <input type="button" value="Cancel"/> |

4.2.1.2 802.IQ v1/v2 Common Features

Auto Startup

This parameter **enables** (✓) 802.IQ immediately when the 9150 is rebooted. When the 9150 is operating as a base station under a network controller or a 9150 mini-controller, this parameter must be **disabled**.

The default value is **disabled**.



Important: *If Auto Startup is set incorrectly, terminals may not operate correctly.*

Beacon Period

An 802.IQ beacon is a broadcast sent out to all 802.IQ-enabled terminals. The beacon allows terminals to determine when they have roamed between base stations. It enables a terminal to determine whether or not the base station or controller was

rebooted and, if so, how to recover. If the controller was rebooted, the terminal closes all sessions and fully re-initializes. If the base station was rebooted, or if the terminal moved to a different 9150, a warm initialize is done (no data will be lost).

The *Beacon Period* parameter acceptable value ranges from **1** to **20** seconds. The default value is **2**.

Terminal Offline Timeout

This parameter sets the time (in minutes) before the 802.IQ task on the 9150 will send an offline message to the cellular master declaring the terminal offline.

The acceptable value ranges from **1** to **240**. The default value is **5**.

4.2.1.3 802.IQ v1 Configuration Submenu

Enabled

This parameter enables (✓) or disables the 802.IQ feature. The default value is **disabled**.

Initial RTT

The parameter *Initial RTT* (Round-Trip Time) is used to help determine the elapsed time, in milliseconds, between an “*access point*” *transmission* and a “*terminal*” *acknowledgement*. The access point continuously adjusts the acceptable round trip time, calculating the average elapsed time over a number of transmissions for each terminal. If an acknowledgement takes longer to receive than the average round trip time calculated, the access point will resend the transmission.

Because access point(s) cannot calculate an *average* round trip time without a number of transmissions, a starting point or “Initial Round Trip Time” is required. The access point uses the time assigned to the “Initial RTT” parameter as a starting value for round trip calculations. Once the access point begins transmitting and receiving data to and from the terminal, this value will be adjusted to reflect the actual average round trip time between transmissions and acknowledgements.

The acceptable value ranges from **10** to **10000**. The default value is **1000**.

Protocol Type ID

This parameter identifies the 802.IQ protocol type, in order to avoid conflicts with other generated ethernet type packets that use the same protocol type.

The acceptable value ranges from **1501** to **65535**. The default value is **2457**.



Important: *The Protocol Type ID default value is rarely changed. If the protocol type is changed, all terminal devices must be changed to match.*

Forward 802.IQ Packets Only

When bridging packets between the wireless and wired systems, this parameter enables the 9150 to automatically filter out and discard all non-802.IQ packets.

The default setting is **disabled**.

Give Higher Priority To 802.IQ Data

When **enabled** (✓), this feature queues 802.IQ packets ahead of all other packet types (excluding voice packets, if applicable). If the parameter is **disabled**, 802.IQ packets are not prioritized and are treated like any other packet type.

The default setting is **enabled**.

4.2.1.4 802.11 Radio Information

The parameters in this menu set general information about the USI WaveLAN IEEE 802.11 DSSS PCMCIA card installed in the 9150.

| 802.11 Radio Information: | |
|------------------------------|--------------------------------------|
| Physical Address: | 00:60:1d:04:b8:c8 |
| AP Radio Name: | <input type="text" value="tkx9150"/> |
| Regulatory Domain: | FCC-USA (0x10) |
| Fixed Multicast Rate: | <input type="text" value="Auto"/> |
| WEP Implemented on the card: | NO |
| WEP Enable: | <input type="checkbox"/> |
| HIDE WEP keys: | <input type="checkbox"/> |
| WEP Tx Key: | <input type="text" value="1"/> |
| WEP Encryption Key 1: | <input type="text"/> |
| WEP Encryption Key 2: | <input type="text"/> |
| WEP Encryption Key 3: | <input type="text"/> |
| WEP Encryption Key 4: | <input type="text"/> |

Physical Address

This parameter shows the hardware address (MAC address) of the radio card. A globally unique MAC address is assigned to each card by the card manufacturer. *The value cannot be changed.*

AP Radio Name

To identify each AP, the monitor uses the radio card's name. The identification can be configured here to give each radio card a unique name.

The *AP Radio Name* is an alphanumeric character string of **up to 32** characters. The default value is **tkx9150**.

Regulatory Domain

The regulatory domain value identifies the regulatory body's country code for the RF regulations with which the radio complies. For the USA, the regulatory body is the FCC, for Canada it's Industry Canada, and for Europe it's ETSI. The hex value in brackets beside the name is the code (as specified in the IEEE 802.11b standard) for that domain. The country codes that are decoded into a name are listed below. For other country codes the name portion will be replaced with "Unknown".

| Regulatory Body | Domain Code | Country |
|-----------------|-------------|--|
| FCC-USA | 0x10 | USA (for DS radios this is also the code used for Canada) |
| Industry Canada | 0x20 | Canada (currently only for FH radios, this may change in the future) |
| ETSI-Europe | 0x30 | Most of Europe |
| Spain | 0x31 | Spain |
| France | 0x32 | France |
| MKK-Japan | 0x40 | Japan |

Fixed Multicast Rate

This parameter allows you to choose the multicast rate of the installed 802.11, 2.4 GHz TRX7431 radio.

The allowable values for TRX7431 are: **Auto**, **1**, **2**, **5.5**, or **11Mb/s**.

If **Auto** is chosen, the rate will automatically be set to the radio card's default multicast rate.

WEP Implemented on the card

This parameter shows whether the radio card installed on the 9150 supports the *Wired-Equivalent Privacy* feature, referred to as WEP. This feature allows you to encrypt radio traffic to prevent electronic eavesdropping. WEP is available in either 64-bit or 128-bit encryption for the TRX7431 radio. If WEP is not implemented by the radio card, the WEP parameters are non-functional.

The allowable values are **Yes** or **No**, and cannot be changed.

WEP Enable

Enabling (✓) this parameter makes WEP available for the radio.

The default is **disabled**.

Hide WEP Keys

This parameter controls access to the WEP keys by replacing the visible key values with the hidden values “****” when the option is enabled (✓). To activate this feature, the WEP key values must first be entered and then submitted by pressing “OK” at the bottom of the page. Then, by going back into the *IEEE 802.11 Direct Sequence Radio Parameters* menu page (the key values will be visible), enable the Hide WEP Keys option, and submit the data again. This time you will see that the key values have been hidden. The feature is now set and remains enabled.

To disable the feature or change any of the WEP key values, you must enter and then submit ALL of the existing and/or new key values. When you go back to the menu pages, the key values will be visible again. The default is **disabled**.

WEP Tx Key

This parameter specifies which WEP Key the 9150 will use when transmitting.

The allowable values are **1** to **4**. The default value is **1**.

WEP Encryption Key 1 to 4

This parameter allows you to set the encryption key for either 64-bit or 128-bit encryption. Acceptable values for a key parameter are shown in Table 4.1.

| 64-bit Encryption | 128-bit Encryption (available with TRX7431 radio only) |
|---------------------------------|--|
| 5 ASCII characters | 13 ASCII characters |
| “0x”, followed by 10 hex digits | “0x”, followed by 26 hex digits |

Table 4.1 WEP Encryption Key Values



Note: *Although the user specifies 40-bit and 104-bit keys, these keys are actually composed with a 24-bit-long “Initialization Vector” generated inside the radio card, making up the 64- and 128-bit keys.*



Important: *The 9150 must be rebooted for changes to these parameters to take effect.*

4.2.1.5 Basic Service Set (BSS) Configuration

The 9150 facilitates roaming of terminals across Basic Service Sets (BSS). For a detailed description, please see “Inter-Access Point Protocol (IAPP)” on page 9.

| Basic Service Set (BSS) Configuration: | |
|--|-------------------------------------|
| Enabled: | <input checked="" type="checkbox"/> |
| ESSID: | TEKLOGIX |
| Allow Broadcast ESSID: | <input type="checkbox"/> |
| Channel: | 10 |
| Data Rate: | Auto |

Enabled

This parameter enables (✓) or disables the BSS feature.

ESSID

This is the *Extended Service Set Identifier* parameter. The ESSID is an alphanumeric character string of **up to 32** characters and is case-sensitive. If your network includes devices that use the DOS ODI Driver, select alphabetical characters in uppercase only to allow the DOS ODI devices to connect to the network as well.



Note: The ESSID should be the same for all devices in a system.

Allow Broadcast ESSID

This parameter enables (✓) or disables the Broadcast ESSID feature. By default, it is unchecked and the association of stations that provide an ESSID that is not equal to this 9150's ESSID is NOT allowed. This prevents the 9150 from being associated with any station (802.11 device within radio range) that has its ESSID set to “ANY” (broadcast SSID).

The default is **disabled**.

Channel

This parameter sets the operating channel for this radio, as determined by the system administrator. For a listing of the allowable channels for each country, please see “PC Card Radios” on page 204.

Data Rate

The *Data Rate* parameter allows you to choose whether to fix the data rate (**Fixed n**) or set a maximum automatic transmission rate (**Auto n**) for the BSS channel of the installed TRX7431 radio. The data rate can also be configured to automatically use the maximum transmission rate possible for the radio (**Auto**).



Important: *The 9150 must be rebooted for changes to this parameter to take effect.*

The range of values is: **Auto**, **Fixed 1**, **Fixed 2**, **Auto 2**, **Fixed 5.5**, **Auto 5.5**, or **Fixed 11Mb/s**.

The default setting is **Auto**.

4.2.1.6 Wireless Distribution System (WDS) Configuration

| Wireless Distribution System (WDS) Configuration: | |
|---|--------------------------|
| Enabled | MAC Address of remote AP |
| <input type="checkbox"/> | 00:00:00:00:00:00 |
| <input type="checkbox"/> | 00:00:00:00:00:00 |
| <input type="checkbox"/> | 00:00:00:00:00:00 |
| <input type="checkbox"/> | 00:00:00:00:00:00 |
| <input type="checkbox"/> | 00:00:00:00:00:00 |
| <input type="checkbox"/> | 00:00:00:00:00:00 |

OK Cancel

The 9150 Wireless Gateway can be used as an 802.11b wireless access point (AP) to extend coverage area or for locations difficult to wire; or two 9150s can be used as an 802.11b bridge connecting two separate wired networks.

The 9150 access points are linked to each other in the Wireless Distribution System (WDS). To do this, each of the 9150s in the WDS must be configured to identify the other access points in the system, using their MAC addresses as described in the following parameter. Examples of various configuration scenarios are provided in Figure 4.2 on page 73 through Figure 4.5 on page 74.



Note: *The Basic Service Set (BSS) operates independently of the WDS. However, the BSS and WDS share the same bandwidth. For information on BSS, please refer to “Basic Service Set (BSS) Configuration” on page 71.*

MAC Address Of Remote AP

Each wireless access point linked to this 9150 must be identified by entering its MAC address here, and the connection must also be enabled (✓). Up to six WDS links can be supported. This 9150's MAC address must also be configured and enabled on each of the other access points linked to it in the Wireless Distribution System.



Important: *If there are two radio cards in the wireless 9150 access point, one radio should be configured for the WDS link, and the other for BSS coverage. If both radio cards are set for the WDS, one will be automatically disabled.*

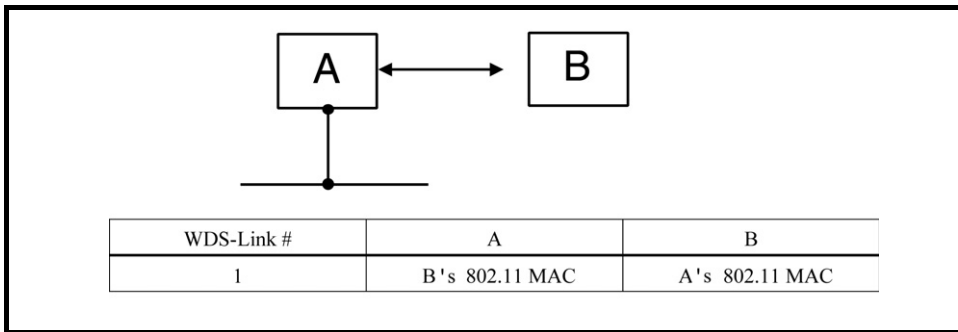

Figure 4.2 WDS Configurations: One Hop To The Backbone

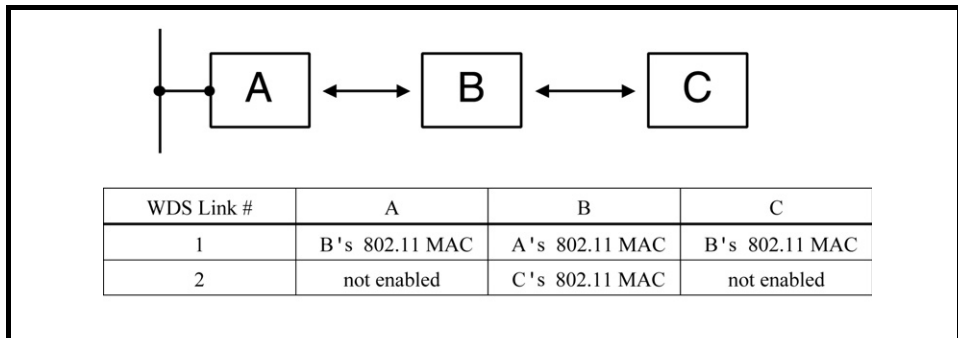

Figure 4.3 WDS: More Than One Hop To The Backbone

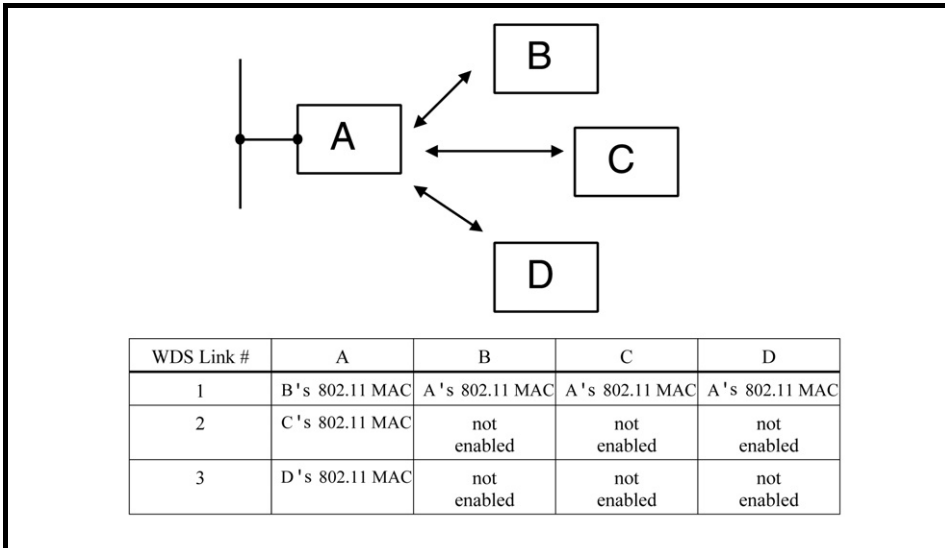

Figure 4.4 WDS: Multiple APs Connected To One AP In The Backbone

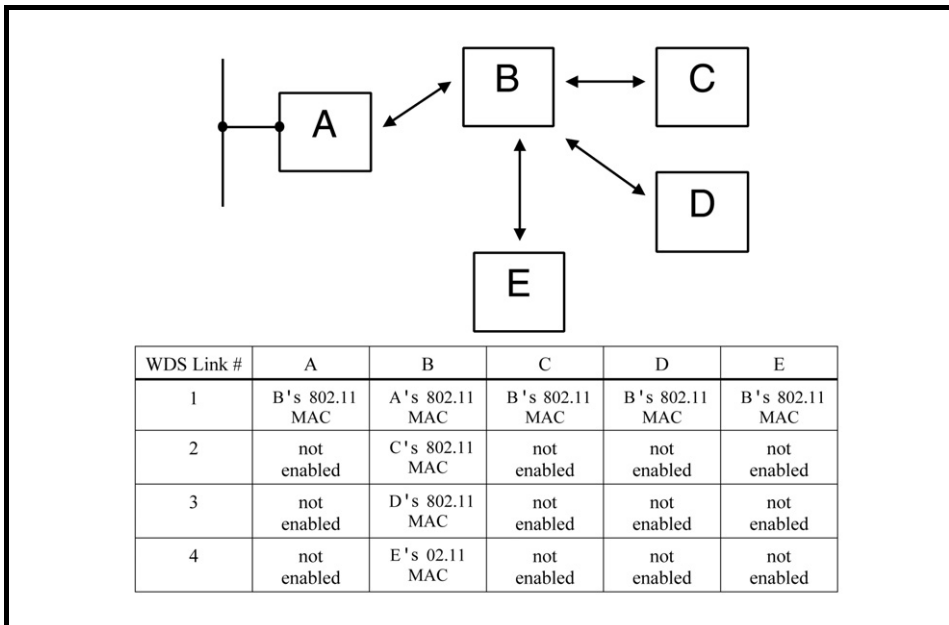
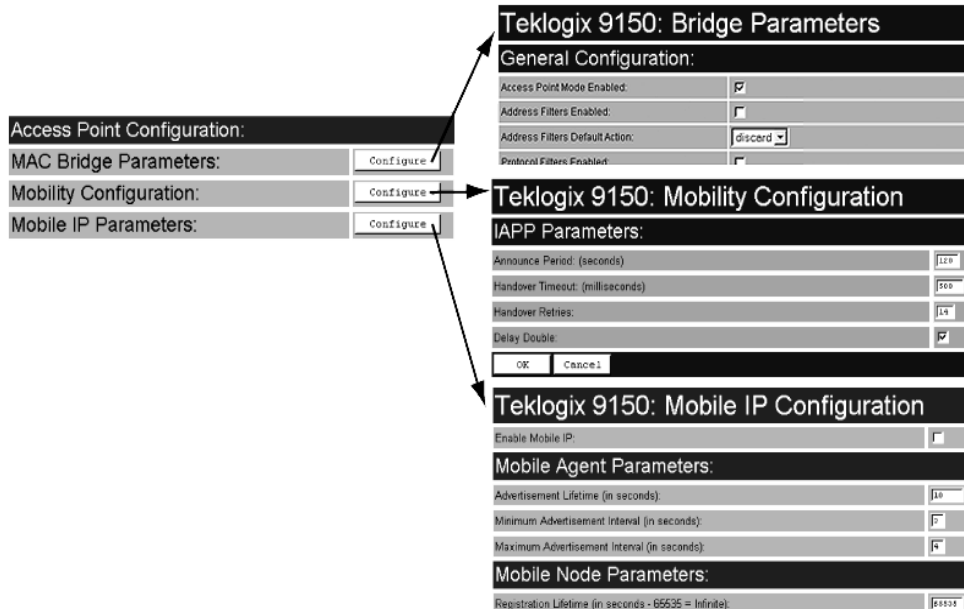

Figure 4.5 WDS: Multiple APs Connected To Another Wireless AP

4.3 Access Point Configuration Menu Options

The Access Point Configuration main menu consists of three sub-menus: *MAC Bridge Parameters*, *Mobility Configuration*, and *Mobile IP Parameters*.



4.4 MAC Bridge Parameters

The MAC Bridge parameters consist of protocol filters that direct the 9150 to forward or discard frames that contain a known protocol type. This enables the 9150 to be selective of what types of frames will be bridged over the radio, in order to limit traffic on busy networks. Filtering frames is based on the protocol information in the frame. This is discussed in detail in “Protocol Filters” on page 83.

The *MAC Bridge Parameters* page is entered from the Access Point Configuration menu on the first page, as shown above.

Figure 4.6 on page 76 charts the pages for the MAC bridge filters. Entering “OK” or “Cancel” in the individual Filter pages will return you to the *Bridge Parameters* page.

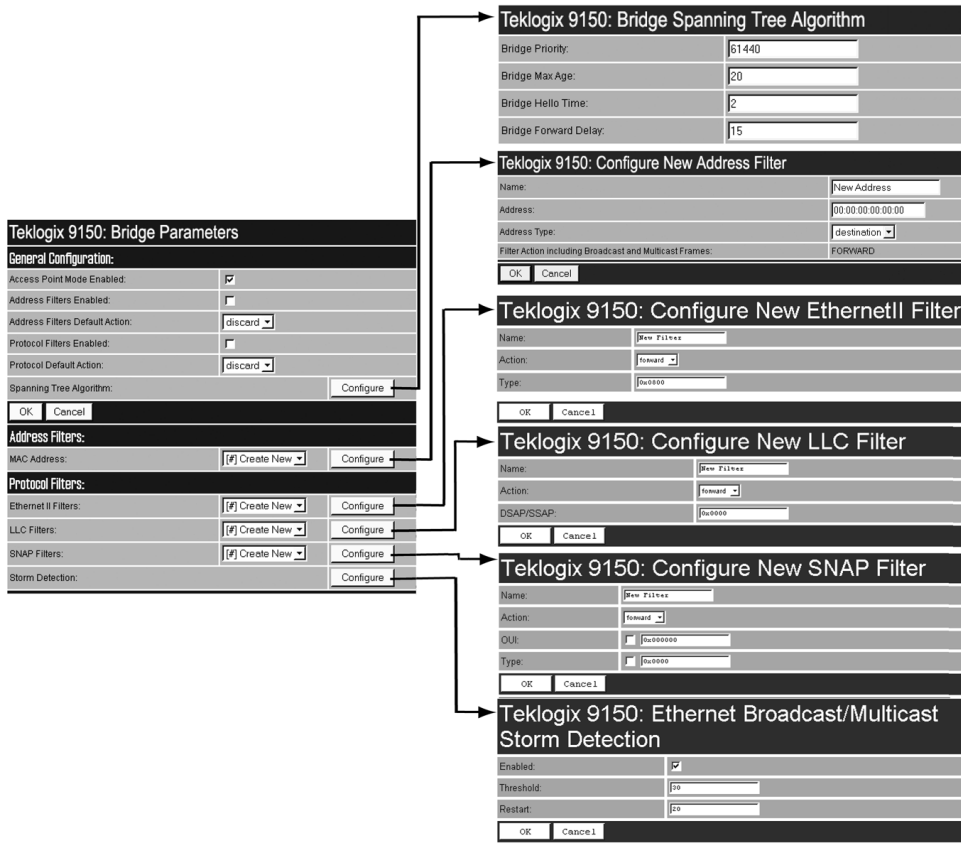

Figure 4.6 Overview Of MAC Bridge Configuration Menus

4.4.1 General Configuration

| Teklogix 9150: Bridge Parameters | |
|---|--|
| General Configuration: | |
| Access Point Mode Enabled: | <input checked="" type="checkbox"/> |
| Address Filters Enabled: | <input type="checkbox"/> |
| Address Filters Default Action: | discard ▾ |
| Protocol Filters Enabled: | <input type="checkbox"/> |
| Protocol Default Action: | discard ▾ |
| Spanning Tree Algorithm: | <input type="button" value="Configure"/> |
| <input type="button" value="OK"/> <input type="button" value="Cancel"/> | |

Access Point Mode Enabled

When this 9150 is used only as an 802.IQ base station and not as an access point, this parameter should be **disabled** to reduce CPU time. Only broadcast and multicast frames will be passed through. **Enable** (✓) this parameter for the 9150 functioning as an access point.

The default value is **enabled**.

Address Filters Enabled

The checkbox in this parameter enables or disables the *Address Filters* function. If filtering is **enabled** (✓), the 9150 can filter out frames based on destination MAC addresses. The list of MAC addresses for filtering is set by the *Address Filters* option on page 81. Frames are filtered and either forwarded or discarded, depending on the rest of the settings in this configuration. If filtering is **disabled**, no filtering will be done based on MAC addresses.

Address Filters Default Action

This parameter determines which *Address Filters Default Action* (**discard** or **forward**) will be performed when the *Address Filters Enabled* parameter is **checked** (✓). If an address **does not match** any of the addresses set in the *Address Filters* configuration (see page 81), then it will take the *Address Filters Default Action* selected in this parameter.

For example, the *Address Filters Default Action* may be to **discard** all frames destined for addresses not matched in the configuration database. Therefore if the address type field is **not matched**, the frame will be discarded. But if an address type field is **matched** in the database, the frame will be forwarded for that address.

Conversely, if the default action is to **forward** all frames destined for addresses **not matched** in the configuration database, those frames will be passed on for those addresses, but frames for an address type field **matched** in the database will be discarded.

Protocol Filters Enabled

The checkbox in this parameter enables or disables the *Protocol Filters* function. If filtering is **enabled** (✓), frames are filtered and either forwarded or discarded, depending on the rest of the settings in this configuration. If filtering is **disabled**, no filtering will be done based on protocol frames.

Protocol Default Action

This parameter determines which *Protocol Default Action* (*discard* or *forward*) will be performed when the *Protocol Filters Enabled* parameter is **checked** (✓). Each Protocol Filter (see page 83) also has a *forward/discard* action associated with it. If a frame does not match any of the filters set in the *Protocol Filters* configuration, then it will take the *Protocol Default Action* selected in this parameter.

For example, the *Protocol Default Action* may be to *discard* all frames. If a type field is **matched** in the configuration database, and the Filters action is *forward*, the frame will be passed on. If the field is **not matched**, then the frame will be discarded. Therefore if you want only IP frames forwarded, after selecting the appropriate IP Type in the Ethernet II Filters (see page 86) the *discard* setting here will drop all frames containing other protocol types.



Important: *If Protocol Filters Enabled is checked, and the Protocol Default Action is discard, an HTTP browser will not be able to access the 9150's configuration pages unless an ARP filter is defined to forward ARP packets. To do this, configure Ethernet II Filters to forward protocol type 0x0806 (ARP) packets (see page 86). Alternatively, you can create a static entry in the ARP table on the computer that is running the browser.*

4.4.1.1 Bridge Spanning Tree Algorithm

The Spanning Tree Algorithm and its Bridge Protocol work to support and maintain MAC Bridge performance.



Important: *These parameters are set with optimum default values. Do not adjust these values without discussing the effects with your Psion Teklogix representative.*

| Teklogix 9150: Bridge Parameters | |
|----------------------------------|--|
| General Configuration: | |
| Access Point Mode Enabled: | <input checked="" type="checkbox"/> |
| Address Filters Enabled: | <input type="checkbox"/> |
| Address Filters Default Action: | discard |
| Protocol Filters Enabled: | <input type="checkbox"/> |
| Protocol Default Action: | discard |
| Spanning Tree Algorithm: | <input type="button" value="Configure"/> |



| Teklogix 9150: Bridge Spanning Tree Algorithm | |
|---|---|
| Bridge Priority: | 61440 |
| Bridge Max Age: | 20 |
| Bridge Hello Time: | 2 |
| Bridge Forward Delay: | 15 |
| Root Port Priority: | 128 |
| Set Port Priority: | Port Number: 0 <input type="button" value="Configure"/> |
| <input type="button" value="OK"/> <input type="button" value="Cancel"/> | |

Bridge Priority

This parameter helps a network manager select the active topology of the Bridged Local Area Network by influencing the selection of the Root Bridge. The 2-octet value is appended as the most significant portion of a bridge ID. A lower numerical value for the bridge priority makes the bridge more likely to become the root.

The default value is **61440** (which equals 0xF000 in hexadecimal notation).

Bridge Max Age

The value of the Maximum Age parameter sent in a Configuration BPDU (Bridge Protocol Data Unit) when the 9150 is the Root or is attempting to become the Root.

The Maximum Age is the message age at which a received configuration message is judged “too old” and is discarded. If the selected value is too small, then occasionally the spanning tree will configure unnecessarily, possibly causing temporary loss of connectivity in the network. If the selected value is too large, the network will take longer than necessary to adjust to a new spanning tree after a topological event such as the restarting or crashing of a bridge or link. A conservative value is to assume a delay variance of 2 seconds per hop. The value recommended by IEEE 802.1d is 20 seconds.

The default value is **20**.

Bridge Hello Time

The time interval between the transmission of Configuration BPDUs by a 9150 that is the Root or is attempting to become the Root.

The recommended time is 2 seconds. Shortening the time will make the protocol more robust, in case the probability of loss of configuration messages is high. Lengthening the time lowers the overhead of the algorithm (because the interval between transmission of configuration messages will be larger).

The default value is **2**.

Bridge Forward Delay

The value of the Forward Delay parameter sent in a Configuration BPDU when the 9150 is the Root or is attempting to become the Root.

The Forward Delay temporarily prevents a bridge from starting to forward data packets to and from a link until news of a topology change has spread to all parts of a bridged network. This should give all links that need to be turned OFF in the new topology time to do so before new links are turned ON.

The default value is **15**.

Root Port Priority

The *Root Port Priority* parameter sets the initial priority value assumed by the Root Port. The default value is **128**.

Set Port Priority

The *Set Port Priority* parameter sets the prioritization of each enabled port. A lower numerical value for the port priority makes the port more likely to become the designated port. **Port Number 1** corresponds to the wired interface; **Port Numbers 2 to 7** correspond to WDSLlinks 1 to 6. To set the priority, enter the port number in the textbox and then press the “Configure” button. Then enter the priority number for that port in the textbox.

Valid values range from **0** to **255**. The default value is **128**.

Teklogix 9150: Bridge Spanning Tree Algorithm

| | |
|-----------------------|---|
| Bridge Priority: | 61440 |
| Bridge Max Age: | 20 |
| Bridge Hello Time: | 2 |
| Bridge Forward Delay: | 15 |
| Root Port Priority: | 128 |
| Set Port Priority: | Port Number: 0 <input type="button" value="Configure"/> |

Teklogix 9150: Port #0 Priority

| | |
|---|-----|
| Port priority: | 128 |
| <input type="button" value="OK"/> <input type="button" value="Cancel"/> | |

4.4.2 Address Filters: MAC Address

The 9150 can use a list of destination MAC addresses to filter out frames. The MAC addresses are those of any terminals associating with the 9150. If *Address Filters Enabled* on page 77 is **checked** (✓) and *Address Filters Default Action* (page 77) is set to **discard**, then any frame destined for any address in the list will be forwarded. If *Address Filters Default Action* is set to **forward**, then those frames will be discarded. Addresses are added to the filter list by entering the “Configure” dialogue box from the *Bridge Parameters* menu.

The screenshot shows the 'Address Filters' configuration interface. At the top, there is a header 'Address Filters:' followed by a 'MAC Address:' field, a '[#] Create New' dropdown menu, and a 'Configure' button. An arrow points from the 'Configure' button to a dialog box titled 'Teklogix 9150: Configure New Address Filter'. This dialog box has several fields: 'Name' with the value 'New Address', 'Address' with the value '00:00:00:00:00:00', 'Address Type' with a dropdown menu set to 'destination', and 'Filter Action including Broadcast and Multicast Frames' with the value 'FORWARD'. At the bottom of the dialog box are 'OK' and 'Cancel' buttons.

Name

This is any name you wish to use to describe this terminal.

Address

This parameter provides the corresponding MAC address for the terminal.

Address Type

This parameter defines whether the **source** or **destination** address of the frame should be used to determine the filter action. The destination address has priority over the source address. Therefore, when a frame is filtered, if its destination address is set for discarding but its source address is set for forwarding, the frame will be discarded.

The default setting is **destination**.

Filter Action Including Broadcast And Multicast Frames

This parameter shows the filter action set in the “Address Filters Default Action” on page 77, which either forwards or discards frames based on the MAC address configured here. If the action is shown as “Forward”, the frames for this address will be discarded. If the action is “Discard”, the frames will be forwarded. The parameter is not configurable in this menu.

4.4.3 Protocol Filters

| Protocol Filters: | | |
|----------------------|------------------|-----------|
| Ethernet II Filters: | [#] Create New ▾ | Configure |
| LLC Filters: | [#] Create New ▾ | Configure |
| SNAP Filters: | [#] Create New ▾ | Configure |
| Storm Detection: | | Configure |

When the 9150 receives frames, it can forward or discard the messages by filtering the protocol Type fields encapsulated in the frame. The filtering is done on three types of Ethernet headers: Ethernet II, LLC and SNAP.

Figure 4.7 on page 84 illustrates the Ethernet header formats. The parameters to configure these filters are described in the sections which follow.



Note: *Throughout these menus, the values for all the protocol types are, by convention, entered in hexadecimal, preceded by “0x”.*

The fields for a basic IEEE 802.3 Ethernet frame consist of a six-byte destination MAC address, followed by a six-byte source MAC address, and a two-byte protocol Type. The final fields in a frame are the Data field and the FCS field (Frame Check Sequence, or CRC). If the Type field contains a value that is greater than or equal to “0x0600”, it is assumed to be the protocol identifier for an Ethernet II header. This field is used to determine which protocol is being used in the frame, and this is what can be filtered (see “Ethernet II Filters” on page 86).

If the protocol Type is less than “0x05DC”, then the value is interpreted as a Length field instead. It is assumed that an IEEE 802.2 Logical Link Control (LLC) header is to follow the Length. This header consists of the **D**estination **S**ervice/**S**ource **S**ervice **A**ccess **P**oint (DSAP/SSAP) and **C**ontrol fields (see “LLC Filters” on page 87).

If the DSAP and SSAP are both “0xAA”, and the Control field has a value of “0x03”, the LLC header will be followed by an extension which is a SNAP header. The SNAP header includes the Organizational Unit Identifier (OUI) and the protocol type (see “SNAP Filters” on page 88).

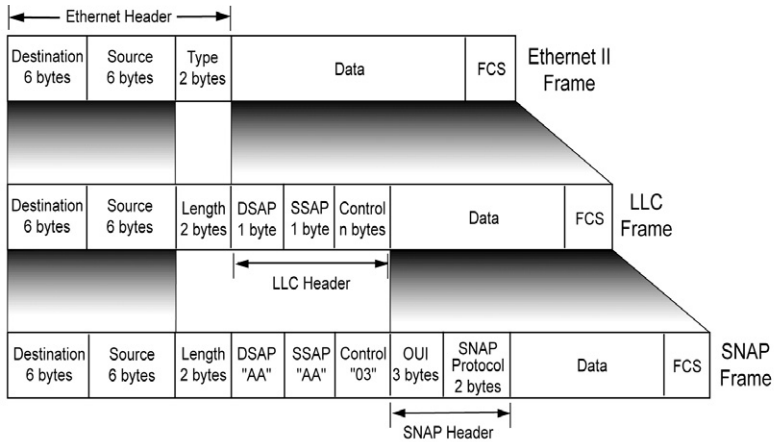

Figure 4.7 Ethernet Frame Types

The listboxes in the *Protocol Filters* option show the protocol filters already set in the configuration database. Selecting a protocol name and then opening the “Configure” dialog box gives a list of parameter settings that can be modified or deleted for that protocol.

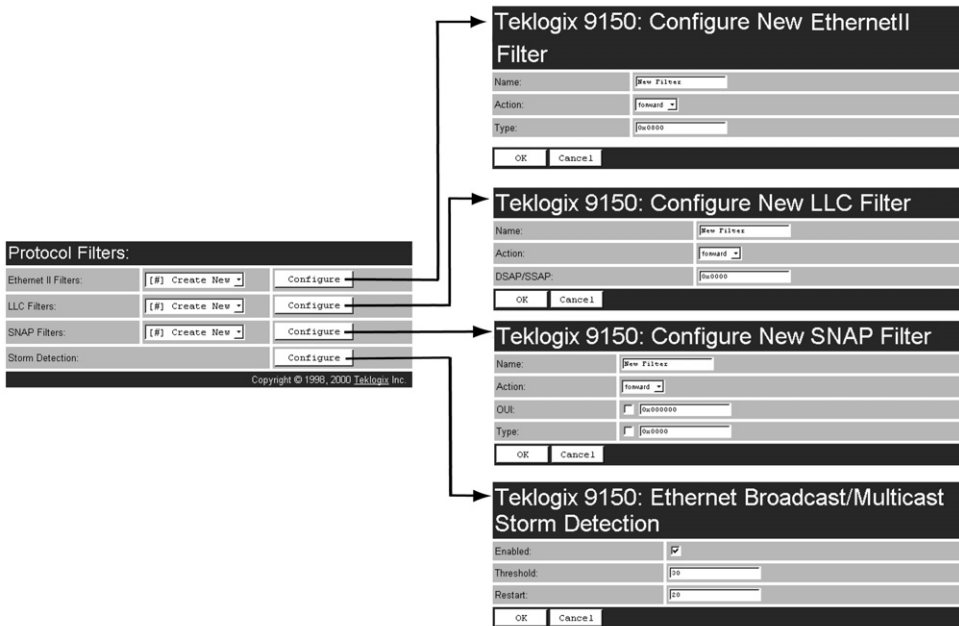
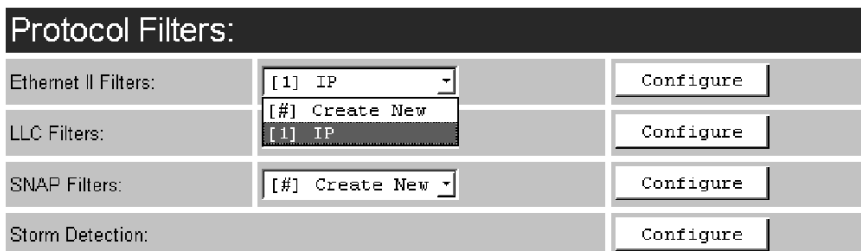

Figure 4.8 Protocol Filters Main Menu And Sub-menus

New filters can be added by selecting “[#] Create New” in the listbox before entering the “Configure” dialog box. Once a filter is created, the option to delete it can be found on its configuration page (for example, see “Ethernet II Filters” on page 86). When choosing to delete a filter, you will be prompted for confirmation of the deletion, which will give you the opportunity to cancel the action.



If a hexadecimal number is entered that is outside the minimum or maximum allowable value for these parameters, you will receive an alert that the Type value is invalid for the specified protocol.

Teklogix 9150: Bad Data

The submitted set of parameters was *not* written to the database because one or more of the parameters submitted were invalid.

The following parameter[s] were invalid:

- filter.ethernetII.1.etherType

OK

4.4.3.1 Ethernet II Filters

Teklogix 9150: EthernetII Protocol Filter

| | |
|---|--------------------------------------|
| Name: | <input type="text" value="IP"/> |
| Action: | <input type="text" value="forward"/> |
| Type: | <input type="text" value="0x0800"/> |
| <input type="button" value="OK"/> <input type="button" value="Cancel"/> <input type="button" value="Delete"/> | |

Name

This is any name you wish to use to describe this Ethernet II filter.

Action

This parameter can be set to either *forward* or *discard* frames with protocol types that match this filter.

Type

The value entered in this parameter must be a four-digit hexadecimal number ranging from **0x0600** to **0xFFFF**, which represents the Ethernet II protocol type you wish to filter. For example, if you only use TCP/IP, create two protocol filters, one to forward IP (Type 0x0800) and the other to forward ARP (Type 0x0806). For a listing of Ethernet II types, see “Ethernet II Types (RFC 1700)” on page C-1.

4.4.3.2 LLC Filters

Teklogix 9150: Configure New LLC Filter

| | |
|------------|------------|
| Name: | New Filter |
| Action: | forward |
| DSAP/SSAP: | 0x0000 |

OK Cancel

Name

This is any name you wish to use to describe this LLC filter.

Action

This parameter can be set to either *forward* or *discard* frames with protocol types that match this filter.

DSAP/SSAP

The value entered in the *Destination Service/Source Service Access Point* (DSAP/SSAP) parameter must be a four-digit hexadecimal number ranging from **0** to **0xFFFF**, where the first pair of digits is the DSAP and the last pair is the SSAP.

For a listing of DSAP/SSAP types, see “DSAP/SSAP Types” on page C-14.

4.4.3.3 SNAP Filters

| Teklogix 9150: Configure New SNAP Filter | |
|---|--|
| Name: | <input type="text" value="New Filter"/> |
| Action: | <input type="text" value="forward"/> |
| OUI: | <input type="checkbox"/> <input type="text" value="0x000000"/> |
| Type: | <input type="checkbox"/> <input type="text" value="0x0000"/> |
| <input type="button" value="OK"/> <input type="button" value="Cancel"/> | |

Name

This is any name you wish to use to describe this SNAP (SubNet Access Protocol) filter.

Action

This parameter can be set to either *forward* or *discard* frames with protocol types that match this filter.

OUI

The value entered in this parameter must be a six-digit hexadecimal number ranging from **0** to **0xFFFFFFFF**, which is the **Organization Unique Identifier**. When this parameter is **enabled** (✓), the OUI will be filtered.

Type

The value entered in this parameter must be a four-digit hexadecimal number ranging from **0** to **0xFFFF**, which represents the SNAP type you wish to filter. When this parameter is **enabled** (✓), this Type will be filtered.

For a short listing of OUI values, see “OUI Values” on page C-15.

4.4.3.4 Storm Detection

This filter parameter can prevent broadcast/multicast storms from spreading throughout the network. Network storms can burden radio traffic with unnecessary data transmissions.

The screenshot shows a configuration dialog box titled "Teklogix 9150: Ethernet Broadcast/Multicast Storm Detection". It contains three rows of settings:

| | |
|------------|-------------------------------------|
| Enabled: | <input checked="" type="checkbox"/> |
| Threshold: | <input type="text" value="200"/> |
| Restart: | <input type="text" value="150"/> |

At the bottom of the dialog are two buttons: "OK" and "Cancel".

Enabled

This parameter enables () or disables the Storm Detection filters.

Threshold

The maximum number of broadcast/multicast frames that should be received in one second is defined in this parameter. When that threshold is exceeded, a broadcast storm is declared. Every broadcast/multicast frame received will be discarded until it is determined that the storm is over (see *Restart*, below). Setting the value for *Threshold* is determined by the characteristics of your network.

The default value is **200**.

Restart

The broadcast storm is determined to be over when the number of broadcast frames received for a one second period is less than or equal to the value entered in this parameter. Setting the value for *Restart* is determined by the characteristics of your network.

The default value is **150**.

4.5 Mobility Configuration

The *Mobility Configuration* page is entered from the *Access Point Configuration* menu on the first page.

| | |
|-----------------------------|-----------|
| Access Point Configuration: | |
| MAC Bridge Parameters: | Configure |
| Mobility Configuration: | Configure |
| Mobile IP Parameters: | Configure |

Going to the *Mobility Configuration* page opens the *IAPP Parameters* options.

| | |
|---------------------------------------|-------------------------------------|
| Teklogix 9150: Mobility Configuration | |
| IAPP Parameters: | |
| Announce Period: (seconds) | 120 |
| Handover Timeout: (milliseconds) | 500 |
| Handover Retries: | 14 |
| Delay Double: | <input checked="" type="checkbox"/> |
| OK | Cancel |

The Inter-Access Point Protocol (IAPP) is an extension to the IEEE 802.11b protocol. In a multiple-9150 system, IAPP facilitates roaming of mobile stations (terminals) among the 9150s, and enables communication and awareness between the 9150s.

Every terminal is associated with one 9150, but it can re-associate with another 9150 to maintain uninterrupted communications. The association is “handed over” from one 9150 to the next. The newly-associated 9150 will receive the terminal’s data frames and pass them onto the LAN. Returning frames are no longer accepted by the original 9150, which has disassociated from that terminal. Returning frames are now accepted by the newly-associated 9150 and passed over the RF to the terminal.

To implement these procedures and coordinate the 9150s, IAPP specifies two message types: *Announce* and *Handover*.

In IAPP *Announce* procedures, when the 9150 is initialized, it sends an IP multicast message to inform the other 9150s in the network that it has become active. It also informs the other 9150s of its continued operation ('alive' status) by periodically multicasting the *Announce* beacon.

The *Handover* protocol is intended to inform the old 9150 that a terminal has been associated with a new 9150, and to update the filter tables of intermediate MAC-bridges to correctly forward frames destined for the terminal. The newly-associated 9150 sends a *Handover* request to the old 9150, which disassociates itself and acknowledges the request.



Important: *These parameters are set with optimum default values. Do not adjust these values without discussing the effects with your Psion Teklogix representative.*

4.5.1 IAPP Parameters

Announce Period

The *Announce Period* parameter indicates the number of seconds between *Announce* broadcasts. For further information, see "Mobility Configuration" on page 90.

Handover Timeout

If there is no response to the *Handover* request by the 9150 within the time specified in the *Handover Timeout* parameter, the request is retransmitted. If no response is received after a number of retries (set in the *Handover Retries* parameter, below), the 9150 will complete the reassociation procedure itself. For further information, see "Mobility Configuration" on page 90.

Handover Retries

This parameter sets the number of times the 9150 will transmit a *Handover* request to the disassociated 9150, before it completes the association transfer itself. See also *Handover Timeout*, above.

Delay Double

The *Delay Double* parameter doubles the amount of *Handover Timeout* between *Handover Retries*. For example, if the first retry is after 500 milliseconds, the next *Handover* request is sent after 1 second, followed by a retry after 2 seconds, etc.

4.6 Mobile IP Parameters

Mobile IP is used to allow mobile nodes (i.e. terminals) to roam seamlessly between different TCP/IP subnets (10.16.xxx.xxx -> 10.128.xxx.xxx), through foreign and home “agents” (9150s), which act as proxies. When the terminal roams away from its home network, the home agent will take all packets destined for the mobile node, and send them on to the foreign agent, which relays the packets to the “node” (terminal).

| | |
|------------------------------------|--|
| Access Point Configuration: | |
| MAC Bridge Parameters: | <input type="button" value="Configure"/> |
| Mobility Configuration: | <input type="button" value="Configure"/> |
| Mobile IP Parameters: | <input type="button" value="Configure"/> |

↓

| | |
|--|--|
| Teklogix 9150: Mobile IP Configuration | |
| Enable Mobile IP: | <input checked="" type="checkbox"/> |
| Mobile Agent Parameters: | |
| Advertisement Lifetime (in seconds): | <input type="text" value="10"/> |
| Minimum Advertisement Interval (in seconds): | <input type="text" value="3"/> |
| Maximum Advertisement Interval (in seconds): | <input type="text" value="4"/> |
| Mobile Node Parameters: | |
| Registration Lifetime (in seconds - 65535 = Infinite): | <input type="text" value="65535"/> |
| Maximum Number of Bindings per Mobile Node: | <input type="text" value="1"/> |
| Maximum Number of Registered Mobile Nodes [acting as home agent]: | <input type="text" value="12"/> |
| Maximum Number of Visiting Mobile Nodes [acting as foreign agent]: | <input type="text" value="12"/> |
| Supported Features: | |
| Allow Simultaneous Binding: | <input type="checkbox"/> |
| Replay Protection [using timestamps]: | <input type="checkbox"/> |
| Gratuitous ARP configuration: | |
| Delay Between Gratuitous ARPs: | <input type="text" value="2"/> |
| Number of Retries: | <input type="text" value="3"/> |
| Security Configuration: | |
| Security Parameter Index [SPI]: | <input type="text" value="333"/> |
| Security Key [MD5]: | <input type="text" value="TEKLOGIXTEKLOG1"/> |
| Replay Protection Timing Slack: | <input type="text" value="300"/> |
| <input type="button" value="OK"/> | <input type="button" value="Cancel"/> |

4.6.1 Mobile IP Configuration

Enable Mobile IP

This parameter enables (✓) or disables the Mobile IP feature.

The default is **disabled**.

4.6.1.1 Mobile Agent Parameters

| Mobile Agent Parameters: | |
|--|---------------------------------|
| Advertisement Lifetime (in seconds): | <input type="text" value="10"/> |
| Minimum Advertisement Interval (in seconds): | <input type="text" value="3"/> |
| Maximum Advertisement Interval (in seconds): | <input type="text" value="4"/> |

Advertisement Lifetime

This parameter is the maximum length of time (in seconds) that the advertisement is considered valid in the absence of further advertisements. If the mobile node does not get an advertisement within this period of time, it will assume it has lost contact with that agent. It will then attempt to register any other agent that it has heard.

The acceptable value ranges from **3** to **30**. The default value is **10**.

Minimum Advertisement Interval

This parameter is the minimum period of time (in seconds) between advertisements. The nominal interval at which the agent advertisements are sent should be 1/3 of the *Advertisement Lifetime* parameter value. This allows the mobile node to miss three successive advertisements before deleting the agent from its list of valid agents.

The acceptable value ranges from **1** to **10**. The default value is **3**.

Maximum Advertisement Interval

This parameter is the maximum period of time (in seconds) between advertisements. The nominal interval at which the agent advertisements are sent should be 1/3 of the *Advertisement Lifetime* parameter value. This allows the mobile node to miss three successive advertisements before deleting the agent from its list of valid agents.

The acceptable value ranges from **1** to **10**. The default value is **4**.

4.6.1.2 Mobile Node Parameters

| Mobile Node Parameters: | |
|--|-------|
| Registration Lifetime (in seconds - 65535 = Infinite): | 65535 |
| Maximum Number of Bindings per Mobile Node: | 1 |
| Maximum Number of Registered Mobile Nodes [acting as home agent]: | 128 |
| Maximum Number of Visiting Mobile Nodes [acting as foreign agent]: | 128 |

Registration Lifetime

This parameter is the maximum registration lifetime that a terminal will register for, in seconds. This value depends on the dynamics of your system. A few tenths of seconds to a few minutes seem appropriate. The value **65535** is equivalent to “infinite” for the parameter using it. If the terminal requests a value that is larger than the value configured in the Home Agent, the registration will be rejected and the terminal will have to retry with a lower value.

The acceptable value ranges from **300** to **65535**. The default value is **65535**.

Maximum Number Of Bindings Per Mobile Node

This parameter represents the maximum number of simultaneously available agents for each mobile node. It should be set to a reasonable value, according to the maximum number of base stations that can be in the mobile node's range simultaneously. Some margin should be taken since although being short on the number of agents will not prevent the system from working, it is not ideal.

The acceptable value ranges from **1** to **5**. The default value is **1**.

Maximum Number Of Registered Mobile Nodes

This parameter is the maximum number of terminals that can register with this 9150 acting as a home agent.

The acceptable value ranges from **1** to **255**. The default value is **128**.

Maximum Number Of Visiting Mobile Nodes

This parameter is the maximum number of terminals that can communicate to the home agent via this 9150 acting as a foreign agent.

The acceptable value ranges from **1** to **255**. The default value is **128**.

4.6.1.3 Supported Features

| Supported Features: | |
|---------------------------------------|--------------------------|
| Allow Simultaneous Binding: | <input type="checkbox"/> |
| Replay Protection [using timestamps]: | <input type="checkbox"/> |

Allow Simultaneous Binding

This parameter enables () multiple (simultaneous) bindings.

The default value is **disabled**.

Replay Protection

This parameter enables () time-stamp based replay protection. The mobile node and home agent values for this parameter must match.

The default value is **disabled**.

4.6.1.4 Gratuitous ARP Configuration

| Gratuitous ARP configuration: | |
|--------------------------------|--------------------------------|
| Delay Between Gratuitous ARPs: | <input type="text" value="2"/> |
| Number of Retries: | <input type="text" value="3"/> |

Delay Between Gratuitous ARPs

This parameter is the delay (in seconds) between gratuitous ARP retransmission.

The acceptable value ranges from **1** to **5**. The default value is **2**.

Number of Retries

This parameter is the maximum number of sent gratuitous ARPs on the home network, when the home agent accepts a registration from a mobile node.

The acceptable value ranges from **1** to **5**. The default value is **3**.

4.6.1.5 Security Configuration

| Security Configuration: | |
|-----------------------------------|---|
| Security Parameter Index [SPI]: | <input type="text" value="333"/> |
| Security Key [MD5]: | <input type="text" value="TEKLOGIXTEKLOGIX"/> |
| Replay Protection Timing Slack: | <input type="text" value="300"/> |
| <input type="button" value="OK"/> | <input type="button" value="Cancel"/> |

Security Parameter Index (SPI)

This parameter is the Security Parameter Index (SPI) of association with the home agent. The SPI value must match the SPI value on the mobile node.

The minimum acceptable value is **256**. The default value is **333**.

Security Key (MD5)

The Security Key parameter is in ASCII text with a maximum length of 16 bytes. The agent key must also match the key on the mobile node.

The default value is **TEKLOGIXTEKLOGIX**.

Replay Protection Timing Slack

This parameter provides Timestamp-based replay protection.



Important: *In order for this parameter to operate, SNTP must also be enabled (see “SNTP” on page 47).*

BASE STATION CONFIGURATION

5

| | |
|---|-----|
| 5.1 Overview | 99 |
| 5.2 General Configuration Menu: Interfaces. | 102 |
| 5.2.1 TekLAN Parameters | 102 |
| 5.2.1.1 Radio. | 103 |
| 5.2.1.2 Wireless LAN Parameters | 105 |
| 5.2.2 Narrow Band Radio Parameters | 106 |
| 5.2.2.1 General Options | 108 |
| 5.2.2.2 TRX7370 Radio Card Parameters. | 108 |
| 5.2.2.3 Connectivity Options: Base Station Mode | 112 |
| 5.2.2.4 Connectivity Options: RRM Mode | 117 |
| 5.3 Base Station Configuration Menu Options | 118 |
| 5.3.1 Base Stations | 118 |
| 5.3.2 RRM Groups | 120 |
| 5.3.2.1 Configure New RRM Group. | 120 |
| 5.3.2.2 RRM Group Menu. | 126 |
| 5.3.3 Radio Link Features | 128 |
| 5.4 Hosts Menu | 131 |
| 5.5 Host Menu Options | 134 |
| 5.5.1 9010 / TCP/IP | 135 |
| 5.5.1.1 General Host Options | 135 |
| 5.5.1.2 Emulation Options. | 136 |
| 5.5.1.3 Protocol Options. | 137 |
| 5.5.1.4 Function Key Mappings | 137 |

5.1 Overview

The 9150 Wireless Gateway can function as either a wired or wireless Base Station, or as a Remote Radio Module (RRM), using a radio link and Psion Teklogix proprietary protocols to facilitate communications with the terminals (see also “Radio Protocols” on page 7).

As a wired base station, the 9150 can communicate with both wireless base stations and terminals using either Adaptive Polling/Contention or Wlan Protocols (see page 11), and is connected to the network controller over a network.

As a wireless base station, the 9150 communicates with the wired base station and mobile terminals using the Wlan Protocol.

As an RRM, the operation and timing of the 9150’s radio link to the terminals is directly controlled by a network controller that uses a timeplexing radio protocol (see “Timeplexing And Cellular Switching”, below). It is connected to the network controller over a network.

Timeplexing And Cellular Switching

There are two methods of operating on the radio link. The first method is called *cellular switching*. It is similar in concept to cellular telephone systems. Here, each base station uses a different radio channel. The terminals monitor the radio link and automatically switch to the channel with best radio reception. This cellular switching capability is transparent to the host.

The second method is called *timeplexing*. Here, all Remote Radio Module (RRM) bases at the site use the same channel. Over a UDP/IP network, a network controller, or the 9150 as a mini-controller, coordinates the polling sequence so that the RRM’s do not transmit simultaneously. This timeplexing capability is also transparent to the host. Timeplexing is suited for sites with low transaction rates.

Cellular switching and timeplexing can be combined within one Teklogix system: a site may operate on two or more channels, with several grouped timeplexed bases using each channel, and cellular switching between the channels.

In all of these cases, the operator may move freely throughout the site without loss of communication. The Teklogix system handles channel-switching and handovers between bases without alerting the user.

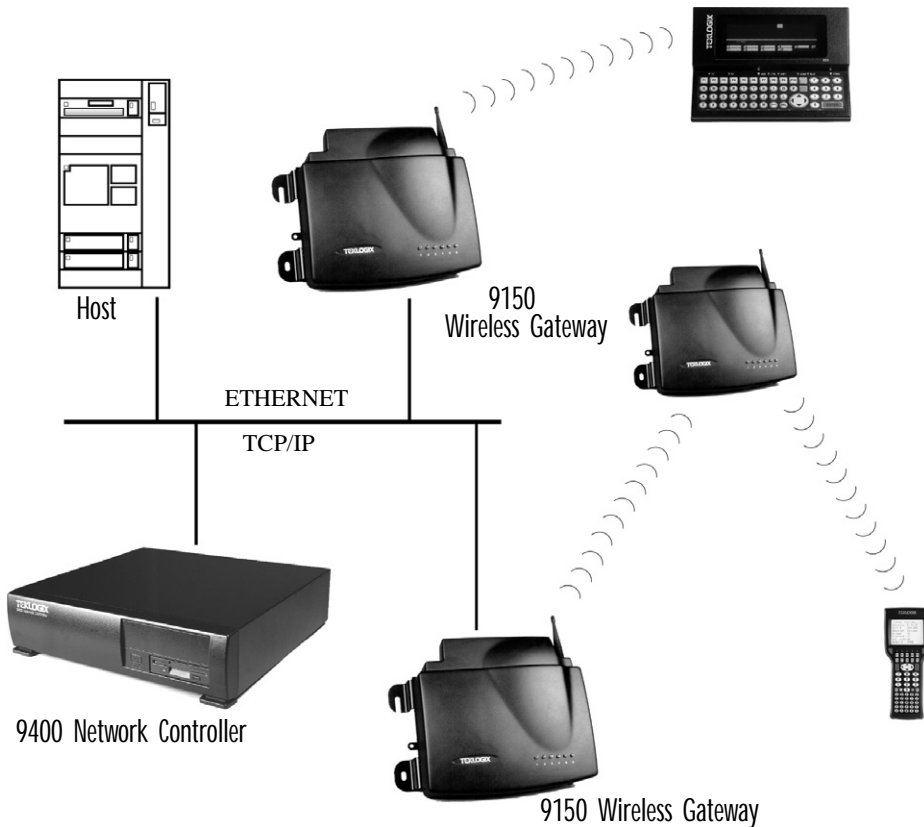

Figure 5.1 9150 Base Station/RRM Configuration

For operation as a base station or RRM, the parameters in the *Base Station Configuration* pages on the *Configuration Main Menu* screen should be set appropriately, as described in the sections that follow. In addition, the appropriate radio and host parameters must be applied. The radio parameters are found in the *Interfaces* pages for *TekLAN* and *Narrow Band* radios. See pages 102 and 106, respectively. The host parameters are found in the *Mini-Controller Configuration: Hosts* pages, which can be found starting on page 131. See Figure 5.2 on page 101 for an overview of the menus involved.



Note: The 9150 main parameters should first be set up as described in Chapter 3: “9150 Main Configuration”. For details on the RF protocols, see page 11.

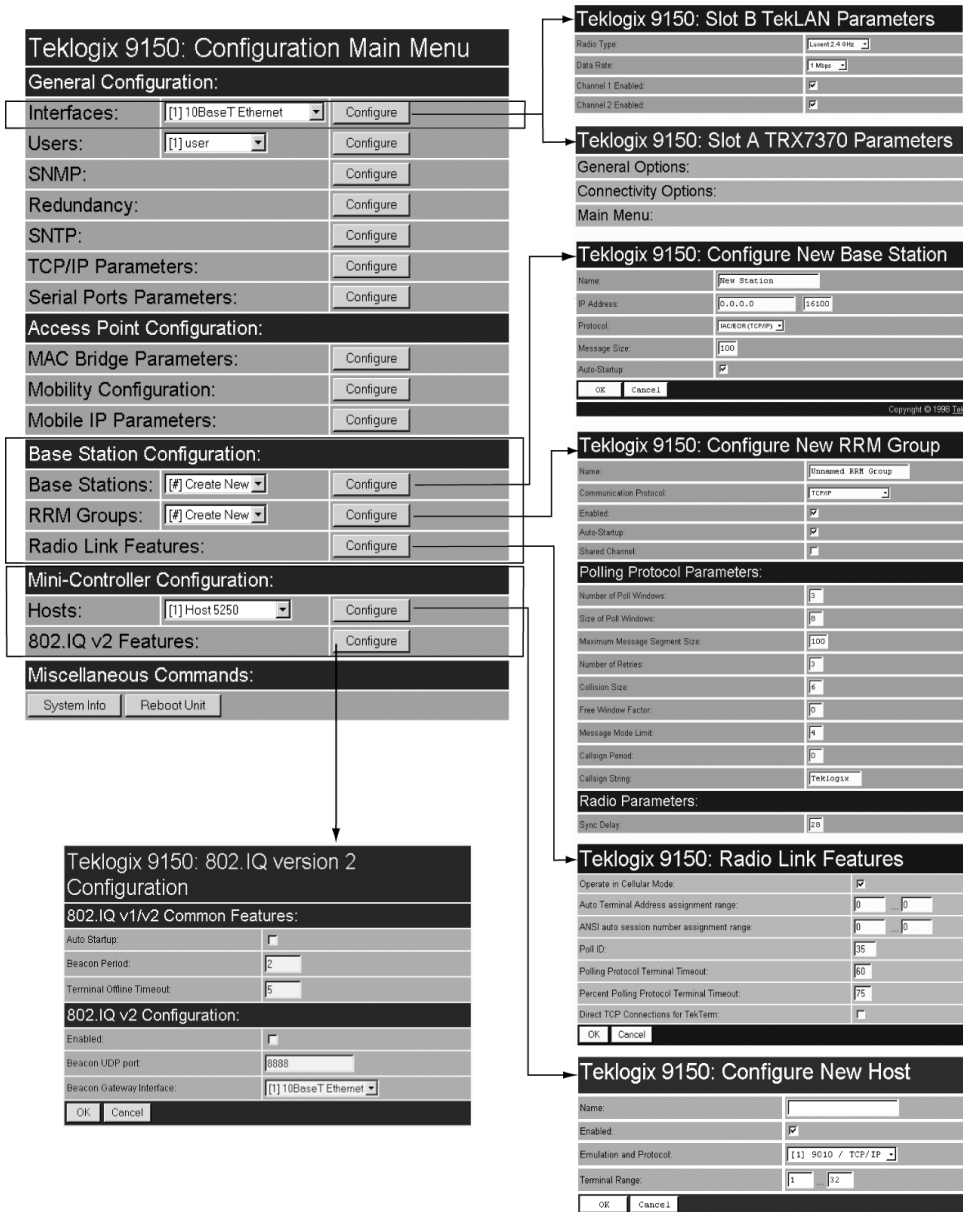

Figure 5.2 Overview Of Menus For Base Station Configuration

5.2 General Configuration Menu: Interfaces

5.2.1 TekLAN Parameters

The pull-down menu shown for the *Interfaces* option in the 9150 *Configuration Main Menu* page indicates which interfaces have been detected in use. Entering the “Configure” dialog box for “Slot A: TekLAN Card”, opens the parameters page for TekLAN, which presents both the radio and Wlan parameters.

The image shows two screenshots of the Teklogix 9150 configuration interface. The top screenshot is the 'Teklogix 9150: Configuration Main Menu' with the 'Interfaces' section expanded. A pull-down menu is open, showing three options: '[1] 10BaseT Ethernet', '[2] Slot A: IEEE 802.11 DS', and '[3] Slot B: TekLAN Card'. A mouse cursor is pointing at the third option. To the right of the menu are three 'Configure' buttons. The bottom screenshot is the 'Teklogix 9150: Slot B TekLAN Parameters' dialog box. It is divided into three sections: 'Radio Type' (set to 'No Radio'), 'Wireless LAN Parameters' (with various checkboxes and dropdowns), and 'Wireless LAN Parameters' (with numerical input fields). At the bottom are 'OK' and 'Cancel' buttons. A copyright notice 'Copyright © 1998 Teklogix Inc.' is at the very bottom.

| Teklogix 9150: Configuration Main Menu | |
|--|----------------------------|
| General Configuration: | |
| Interfaces: | [2] Slot A: IEEE 802.11 DS |
| Users: | [1] 10BaseT Ethernet |
| SNMP: | [2] Slot A: IEEE 802.11 DS |
| | [3] Slot B: TekLAN Card |

| Teklogix 9150: Slot B TekLAN Parameters | |
|---|-------------------------------------|
| Radio Type: | No Radio |
| Data Rate: | 422 Kbps |
| Channel 1 Enabled: | <input checked="" type="checkbox"/> |
| Channel 2 Enabled: | <input checked="" type="checkbox"/> |
| Channel 3 Enabled: | <input checked="" type="checkbox"/> |
| Channel 4 Enabled: | <input checked="" type="checkbox"/> |
| Channel 5 Enabled: | <input checked="" type="checkbox"/> |
| Channel 6 Enabled: | <input checked="" type="checkbox"/> |
| Channel 7 Enabled: | <input checked="" type="checkbox"/> |
| Active Channel: | 1 |
| Range: | 2412-2482 MHz |
| Enable Card: | <input checked="" type="checkbox"/> |
| Auto Startup: | <input checked="" type="checkbox"/> |

| Wireless LAN Parameters | |
|---------------------------|-------------------------------------|
| Base Number: | 1 |
| Wired Network Connection: | <input checked="" type="checkbox"/> |
| Timeout: | 10 |
| Max Priority: | 20 |
| Base Priority: | 2 |
| Message Duration: | 15 |
| Offline Timeout: | 0 |

OK Cancel

Copyright © 1998 Teklogix Inc.

Figure 5.3 Overview Of TekLAN Menus

5.2.1.1 Radio

| Teklogix 9150: Slot B TekLAN Parameters | |
|---|-------------------------------------|
| Radio Type: | Lucent .4 GHz ▾ |
| Data Rate: | 122 Kbps ▾ |
| Channel 1 Enabled: | <input checked="" type="checkbox"/> |
| Channel 2 Enabled: | <input checked="" type="checkbox"/> |
| Channel 3 Enabled: | <input checked="" type="checkbox"/> |
| Channel 4 Enabled: | <input checked="" type="checkbox"/> |
| Channel 5 Enabled: | <input checked="" type="checkbox"/> |
| Channel 6 Enabled: | <input checked="" type="checkbox"/> |
| Channel 7 Enabled: | <input checked="" type="checkbox"/> |
| Active Channel: | 1 |
| Range: | 2412-2462 MHz ▾ |
| Enable Card: | <input checked="" type="checkbox"/> |
| Auto Startup: | <input checked="" type="checkbox"/> |

Radio Type

The type of PC radio card installed on the 9150 is dependent on your wireless network. This parameter should be set to the installed radio. The TekLAN radio is the TekLAN 902 MHz DS Spread Spectrum.



Important: *If changing radio types in the 9150, DO NOT “hot swap” the PC cards: turn the 9150 off before changing the radio. Following this, when changing the Radio Type parameter, the unit must be powered OFF and ON again (“cold” rebooted). Rebooting with the Reboot Unit option will not implement the radio parameter change.*

Data Rate

This parameter determines the data (baud) rate for the radio channel. This is a decimal value in bits per second. The acceptable value for the *Data Rate* parameter for the TekLAN 902 MHz DS SS is **122kb/s**.

Channel n Enabled

These parameters are used to **enable** (✓) or **disable** a channel. The number of channels available is determined by the type of radio installed. See “PC Card Radios” on page 204 for the number of available channels for each radio type.

Active Channel

This parameter determines the current default radio channel.

Range

The federal agencies, Industry Canada and the Federal Communications Commission in the United States, as well as other country-specific agencies world-wide, regulate the use of radio frequencies to ensure that communication conflicts are avoided. See “PC Card Radios” on page 204 for the assigned frequencies for each radio type.

The *Range* parameter determines which channels can be enabled and is set according to the approved frequency range in the country where the system is installed. The TekLAN 902 MHz radio is only assigned the 902 MHz frequency.

Enable Card

This parameter **enables** the PC card (✓). The card may be **disabled** temporarily when, for testing purposes, it is required that there be no radio interference.

Auto-Startup

This parameter **enables** (✓) polling immediately when the 9150 is rebooted. If *Auto-Startup* is **disabled**, the 9150 will wait until polling is initialized from the network controller. When the 9150 is operating as a Wlan base station under a network controller, this parameter should be **disabled**.

5.2.1.2 Wireless LAN Parameters

The Wlan protocol can only be used with spread spectrum radios.

| Wireless LAN Parameters | |
|---|-------------------------------------|
| Base Number: | <input type="text" value="1"/> |
| Wired Network Connection: | <input checked="" type="checkbox"/> |
| Timeout: | <input type="text" value="10"/> |
| Max Priority: | <input type="text" value="20"/> |
| Base Priority: | <input type="text" value="2"/> |
| Message Duration: | <input type="text" value="15"/> |
| Offline Timeout: | <input type="text" value="0"/> |
| <input type="button" value="OK"/> <input type="button" value="Cancel"/> | |



Important: *If your system is using the Wlan protocol, make sure that **Operate in Cellular Mode** is enabled (see page 128) in the **Radio Link Features** sub-menu and that cellular mode is also set on the 9400/ Network Controller.*

Base Number

This parameter is used to assign a unique address to each base station. As the terminals move from one base station to another, this address is transmitted by the base stations to the terminals, identifying each 9150 on a multiple base station system. The allowable range of base station numbers is **1** to **64**.

Wired Network Connection

This parameter should be **enabled** (✓) if the 9150 is directly connected (wired) to the network. If the 9150 is a wireless base station, this parameter should be **disabled**.

The default setting is **enabled**.

Timeout

This value is used to adjust Wlan performance and should be set to **10**.

Max Priority

This value is used to adjust Wlan performance and should be set to **20**.

Base Priority

The *Base Priority* parameter determines the number of priority transmit slots reserved for each base station. The allowable range for this parameter is **0** to **100**. For optimal performance, this parameter should be set to a value of **2**.

Message Duration

This parameter controls the duration of transmit slots to optimize communications and decrease the likelihood of collisions. A *Message Duration* value of **1** translates into a slot duration of 130 micro seconds. The allowable range for this parameter is **2** to **200**. For optimal performance, this parameter should be set to **15**.

Offline Timeout

This parameter determines the time in minutes that a terminal is allowed to be inactive before the 9150 declares it offline. An offline terminal is still considered part of the system. Messages to offline terminals are queued at the 9150. The terminal remains offline until it transmits any message. Values for this parameter range from **0** to **100**. If the parameter is set to **0**, terminals are never declared offline.

5.2.2 Narrow Band Radio Parameters

The pull-down menu shown for the *Interfaces* option on the 9150 *Configuration Main Menu* page indicates which interfaces have been detected in use. For the selection “Slot A: Teklogix Narrowband”, entering the “Configure” dialog box will display the *Slot A TRX7370 Parameters* menu for the TRX7370 Narrow Band PC card radio, as shown in Figure 5.4 on page 107. The *Slot A TRX7370 Parameters* menu has two configuration sub-menus:

“General Options”

When you select this sub-menu, the page displayed allows you to set the operating options for the 9150 in either base station or RRM mode, and to retrieve the radio card’s permanent communications settings.

“Connectivity Options”

When you select this sub-menu, the 9150 displays the Parameters page of the operating mode for which the 9150 is set (base station or RRM).

There is also a *Main Menu* button. When you select this button, the 9150 displays the *Configuration Main Menu* (see page 101).

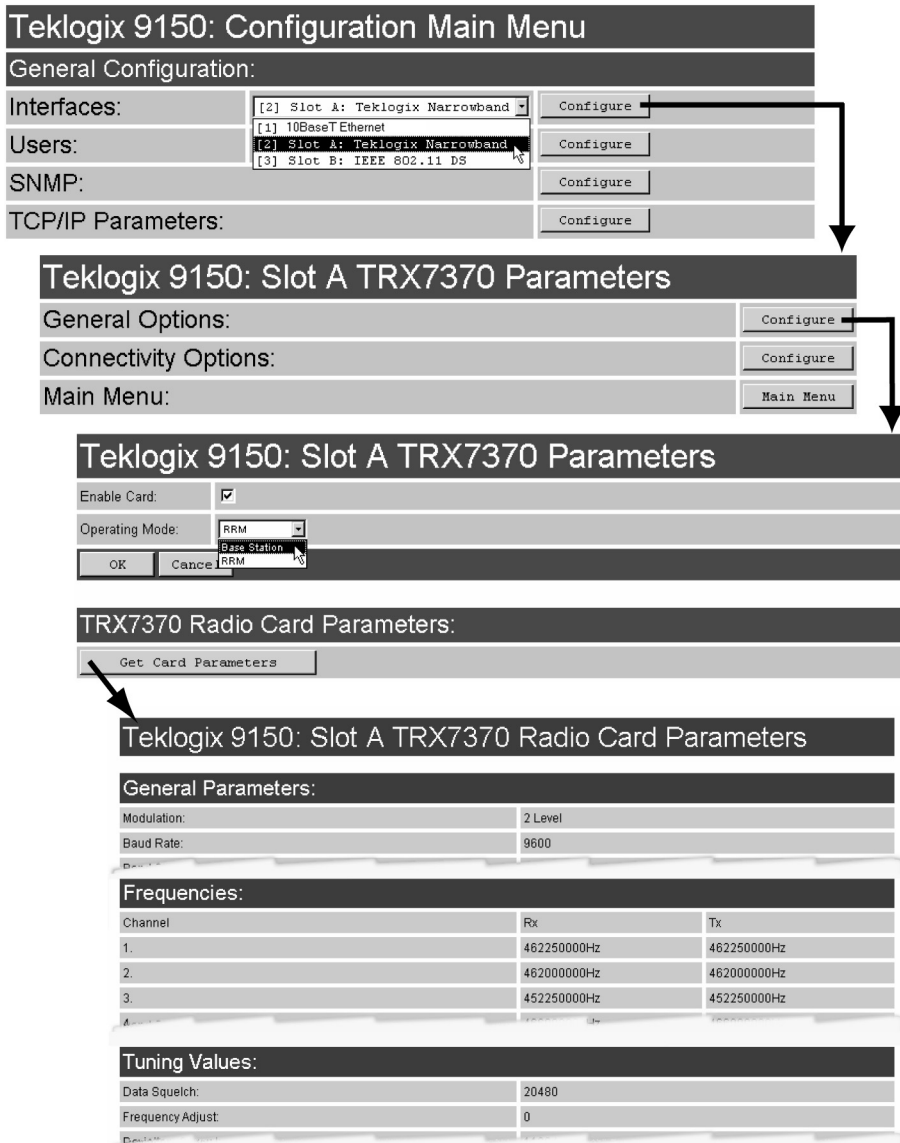
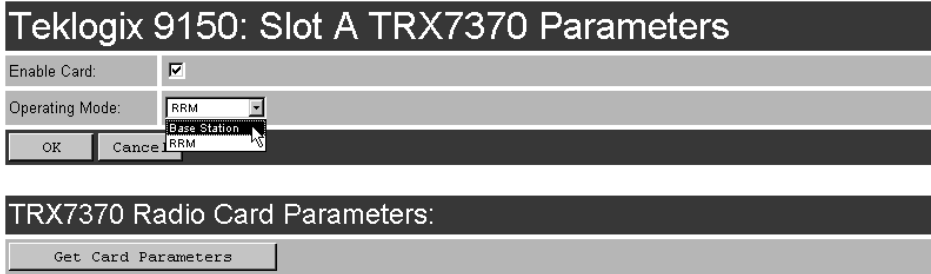

Figure 5.4 Overview Of Teklogix Narrow Band Menus

5.2.2.1 General Options



When you select this sub-menu, the page displayed allows you to set the operating options for the 9150, and to retrieve the TRX7370 radio card’s permanent communications settings.

Enable Card

This parameter **enables** the PC card (✓). The card may be **disabled** temporarily when, for testing purposes, it is required that there be no radio interference.



Important: *If changing radio types in the 9150, DO NOT “hot swap” the PC cards: turn the 9150 off before changing the radio.*

Operating Mode

This parameter allows you to set the operating mode of the 9150 as **Base Station** or **RRM**.

5.2.2.2 TRX7370 Radio Card Parameters

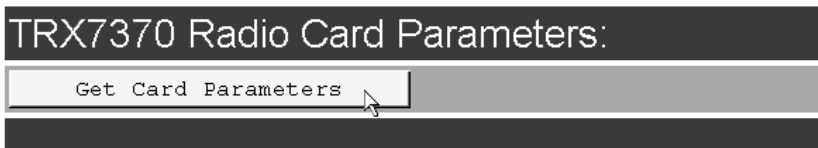

Entering the “Get Card Parameters” dialog box will open the list of *General*, *Frequencies*, and *Tuning Values* parameters for the TRX7370 Narrow Band PC card radio. These manufacturer’s settings are not configurable. The settings are shown on pages 110 and 111.

Teklogix 9150: Slot A TRX7370 Radio Card Parameters

General Parameters:

| | |
|----------------------|-------------------|
| Modulation: | 2 Level |
| Baud Rate: | 9600 |
| Band Start: | 450MHz |
| Band Size: | 16MHz |
| Frequency Step: | 6250Hz |
| Power: | 2W, full power |
| Collision Threshold: | 30ms |
| Preamble, 2 Level: | 10DEL, 1SOH chars |
| Preamble, 4 Level: | 6DEL, 1SOH chars |

OK

Frequencies:

| Channel | Rx | Tx |
|---------|-------------|-------------|
| 1. | 462250000Hz | 462250000Hz |
| 2. | 462000000Hz | 462000000Hz |
| 3. | 452250000Hz | 452250000Hz |
| 4. | 466000000Hz | 466000000Hz |
| 5. | 453250000Hz | 453250000Hz |
| 6. | 453750000Hz | 453750000Hz |
| 7. | 454250000Hz | 454250000Hz |
| 8. | 454750000Hz | 454750000Hz |
| 9. | 455250000Hz | 455250000Hz |
| 10. | 455750000Hz | 455750000Hz |
| 11. | 456250000Hz | 456250000Hz |
| 12. | 456750000Hz | 456750000Hz |
| 13. | 457250000Hz | 457250000Hz |
| 14. | 457750000Hz | 457750000Hz |
| 15. | 458250000Hz | 458250000Hz |
| 16. | 458750000Hz | 458750000Hz |
| 17. | 459250000Hz | 459250000Hz |
| 18. | 459750000Hz | 459750000Hz |
| 19. | 460250000Hz | 460250000Hz |
| 20. | 460750000Hz | 460750000Hz |

Tuning Values:

| | |
|--------------------------------|-------|
| Data Squelch: | 20480 |
| Frequency Adjust: | 0 |
| Deviation, 2 Level: | 11264 |
| Deviation, 4 Level, Subband 1: | 14704 |
| Deviation, 4 Level, Subband 2: | 14704 |
| Deviation, 4 Level, Subband 3: | 14704 |
| Deviation, 4 Level, Subband 4: | 14704 |
| Deviation, 4 Level, Subband 5: | 14704 |
| Modulation Balance, Subband 1: | 1414 |
| Modulation Balance, Subband 2: | 1414 |
| Modulation Balance, Subband 3: | 1414 |
| Modulation Balance, Subband 4: | 1414 |
| Modulation Balance, Subband 5: | 1414 |

Copyright © 1998 Teklogix Inc.

General Parameters

| General Parameters: | |
|----------------------|-------------------|
| Modulation: | 2 Level |
| Baud Rate: | 9600 |
| Band Start: | 450MHz |
| Band Size: | 16MHz |
| Frequency Step: | 6250Hz |
| Power: | 2W, full power |
| Collision Threshold: | 30ms |
| Preamble, 2 Level: | 10DEL, 1SOH chars |
| Preamble, 4 Level: | 6DEL, 1SOH chars |
| OK | |

Frequencies

| Frequencies: | | |
|--------------|-------------|-------------|
| Channel | Rx | Tx |
| 1. | 462250000Hz | 462250000Hz |
| 2. | 462000000Hz | 462000000Hz |
| 3. | 452250000Hz | 452250000Hz |
| 4. | 466000000Hz | 466000000Hz |
| 5. | 453250000Hz | 453250000Hz |
| 6. | 453750000Hz | 453750000Hz |
| 7. | 454250000Hz | 454250000Hz |
| 8. | 454750000Hz | 454750000Hz |
| 9. | 455250000Hz | 455250000Hz |
| 10. | 455750000Hz | 455750000Hz |
| 11. | 456250000Hz | 456250000Hz |
| 12. | 456750000Hz | 456750000Hz |
| 13. | 457250000Hz | 457250000Hz |
| 14. | 457750000Hz | 457750000Hz |
| 15. | 458250000Hz | 458250000Hz |
| 16. | 458750000Hz | 458750000Hz |
| 17. | 459250000Hz | 459250000Hz |
| 18. | 459750000Hz | 459750000Hz |
| 19. | 460250000Hz | 460250000Hz |
| 20. | 460750000Hz | 460750000Hz |

Tuning Values

| Tuning Values: | |
|--------------------------------|-------|
| Data Squelch: | 20480 |
| Frequency Adjust: | 0 |
| Deviation, 2 Level: | 11264 |
| Deviation, 4 Level, Subband 1: | 14704 |
| Deviation, 4 Level, Subband 2: | 14704 |
| Deviation, 4 Level, Subband 3: | 14704 |
| Deviation, 4 Level, Subband 4: | 14704 |
| Deviation, 4 Level, Subband 5: | 14704 |
| Modulation Balance, Subband 1: | 1414 |
| Modulation Balance, Subband 2: | 1414 |
| Modulation Balance, Subband 3: | 1414 |
| Modulation Balance, Subband 4: | 1414 |
| Modulation Balance, Subband 5: | 1414 |

5.2.2.3 Connectivity Options: Base Station Mode

When you enter the *Connectivity Options* sub-menu for the 9150 set in base station operating mode, the 9150 displays the Polling Protocol Parameters and Radio Parameters.

The image shows two screenshots of the Teklogix 9150 configuration interface. The top screenshot shows the main menu with three options: 'General Options', 'Connectivity Options', and 'Main Menu'. Each option has a corresponding 'Configure' or 'Main Menu' button. An arrow points from the 'Connectivity Options' button to the second screenshot. The second screenshot shows the 'Connectivity Options' sub-menu, which is divided into three sections: 'Auto-Startup' (with checkboxes for 'Auto-Startup' and 'Shared Channel'), 'Polling Protocol Parameters' (with numeric input fields for 'Number of Poll Windows', 'Size of Poll Windows', 'Maximum Message Segment Size', 'Number of Retries', 'Collision Size', 'Free Window Factor', 'Message Mode Limit', 'Callsign Period', and 'Callsign String'), and 'Radio Parameters' (with numeric input fields for 'Sync Delay', 'Remote Txon', and 'Active Channel'). At the bottom of the second screenshot are 'OK' and 'Cancel' buttons. A copyright notice 'Copyright © 1999 Teklogix Inc.' is visible at the bottom right of the second screenshot.

| Teklogix 9150: Slot A TRX7370 Parameters | |
|--|-----------|
| General Options: | Configure |
| Connectivity Options: | Configure |
| Main Menu: | Main Menu |

| Teklogix 9150: Slot A TRX7370 Parameters | |
|--|-------------------------------------|
| Auto-Startup: | <input checked="" type="checkbox"/> |
| Shared Channel: | <input type="checkbox"/> |
| Polling Protocol Parameters: | |
| Number of Poll Windows: | 3 |
| Size of Poll Windows: | 8 |
| Maximum Message Segment Size: | 100 |
| Number of Retries: | 3 |
| Collision Size: | 6 |
| Free Window Factor: | 0 |
| Message Mode Limit: | 4 |
| Callsign Period: | 0 |
| Callsign String: | Teklogix |
| Radio Parameters: | |
| Sync Delay: | 22 |
| Remote Txon: | 13 |
| Active Channel: | 1 |
| OK | Cancel |

Copyright © 1999 Teklogix Inc.

Auto-Startup

This parameter **enables** (✓) polling immediately when the 9150 is rebooted. If *Auto-Startup* is **disabled**, the 9150 will wait until polling is initialized from the network controller.

Shared Channel

Shared Channel is only used in Holland to accommodate government requirements. When **enabled** (✓), it imposes timing restrictions for polling. Every 2 seconds of polling is followed by 0.5 seconds of silence—no polling occurs.

Further, if another carrier is detected on the channel, the 9150 will cease radio transmissions on that channel until the path is clear.

POLLING PROTOCOL PARAMETERS

| Polling Protocol Parameters: | |
|-------------------------------|----------|
| Number of Poll Windows: | 3 |
| Size of Poll Windows: | 8 |
| Maximum Message Segment Size: | 100 |
| Number of Retries: | 3 |
| Collision Size: | 6 |
| Free Window Factor: | 0 |
| Message Mode Limit: | 4 |
| Callsign Period: | 0 |
| Callsign String: | Teklogix |

Number of Poll Windows

This parameter defines the number of poll windows the 9150 will use. The value assigned to this parameter is dependent on the number of terminals and the radio link protocol used.

Table 5.1 on page 114 indicates how the value assigned to the *Number of Poll Windows* parameter is determined.

| Number of Terminals | Minimum # of Windows |
|---------------------|----------------------|
| 1-16 | 2 |
| 17-81 | 3 |
| 82-256 | 4 |

Table 5.1 Number Of Poll Windows – Cellular Protocol

Size of Poll Windows

The value assigned to this parameter determines the largest message that can be passed between the 9150 and the terminal in a normal poll window. The window size can be adjusted to accommodate anywhere from **4** to **32** characters.

Larger windows increase the polling period and can increase the response time. Smaller windows increase the number of message and long message polls, and can also increase the response time.



Important: In “Cellular” mode, the minimum value for this parameter is **8**.

Maximum Message Segment Size

This parameter determines the largest single message that can be passed *to* a terminal in message mode or *from* a terminal in long message mode. In a 9150 base station, the value entered in this parameter must be greater than or equal to the value entered in the network controller or 9150 mini-controller. The range of this parameter is between 32 and 116 characters. (Longer messages are broken into several packets.) The default value is **100**.

Number of Retries

This parameter determines how many times the 9150 attempts to resend a message if an acknowledgement is not received from the terminal. (These retries do not necessarily occur in consecutive polls because incomplete messages are returned to the bottom of the message queue.) After all retries have been exhausted, the terminal is declared “offline”. The 9150 does not transmit any messages to the terminal until the terminal declares itself “online”. The allowable values range from **1** to **7**.

Collision Size

This parameter reduces the probability that random noise on the radio link will be interpreted as a collision between terminals. Response time increases when the 9150 resolves collisions unnecessarily.

Collision Size places an upper limit on the number of characters that are received prior to the receipt of an error message (CRC, CD lost, etc.). If eight is the value of this parameter, eight or less characters followed by an error message appearing over the radio link are considered noise. If there are more than eight characters, it is considered a collision. Acceptable values range from **3** to **15**.

Free Window Factor

The value entered in this parameter determines if “free window mode” will be used. In free window mode, all terminals that are not assigned any other window can use the free window.

Entering a value of **0** (zero) in this parameter **disables** free window mode. Increasing the value of this parameter increases the likelihood of a message being transmitted in the free window.

Message Mode Limit

This parameter defines an upper limit to the number of messages that must be queued for transmission before message mode polling starts. Accepted values range from **0** to **7**, where **0 disables** message mode.



Note: *The number of terminals and past events are also part of the algorithm that determines whether or not to start message mode.*

Callsign Period

A call sign is periodically transmitted as an audible Morse code signal. This parameter specifies the interval in minutes between call sign transmissions. Acceptable values range from **0** to **60**. The federal agencies, Industry Canada and the Federal Communications Commission in the United States, require that each system transmit its own identification call sign every 15 minutes.

In countries where a call sign is not required, setting this parameter to **0** prevents the transmission of any call signs, allowing for shorter poll time-outs in terminals and faster channel switching.