

# **Workabout MX**

# **Service Manual**



Psion part no: A6124-0002-02  
Version 2.0 - 2000  
English



© Copyright Enterprise Computing Ltd 2000.

All rights reserved. This manual and the programs referred to herein are copyrighted works of Psion Enterprise Computing Ltd, 92 Milton Park, Abingdon, OX14 4RY, United Kingdom. Reproduction in whole or in part, including utilisation in machines capable of reproduction or retrieval, without the express written permission of Psion Enterprise Computing Ltd is prohibited. Reverse engineering is also prohibited.

The information in this document is subject to change without notice.

Psion and the Psion logo are registered trademarks, and Psion Workabout, MX, 3Link, SSD and Solid State Disk are trademarks of Psion PLC.

Some names referred to are registered trademarks.

Psion Enterprise reserves the right to change the designs and specifications of its products at any time without prior notice.

Psion part no: A6124-0002-02  
Version 2.0 - May 2000  
English

## Note



The Psion Workabout contains CMOS devices that may be damaged by electrostatic discharge (ESD). The following steps to minimise ESD must be taken before the unit is dismantled. To prevent any damage that could result if the unit or its parts are not handled properly, observe the following precautions during any handling procedures:

- Minimise all handling of static-sensitive components and assemblies.
- Transport and store static-sensitive components and assemblies in their original containers or in anti-static bags.
- Label accordingly any package that contains static-sensitive components or assemblies.
- Discharge static electricity from the body by wearing a grounded anti-static wrist strap while handling these components. Servicing static-sensitive components or assemblies should be done only at a static-free workstation by qualified service technicians. Increasing the humidity in the work area minimises static electricity problems.
- Do not allow anything that can generate or hold a static charge on the workstation surface.
- Pick up components by their bodies, never by their leads.
- Do not slide components over any surface.
- Avoid handling components in areas with a floor or work-surface covering that can generate static charge.

### FCC Information for the USA

#### *Radio and Television Interference:*

This equipment radiates radio frequency energy and if not used properly - that is, in strict accordance with the instructions in this manual - may cause interference to Radio and Television reception. It has been tested and found to comply with the limits for a Class B computing device pursuant to part 15 of the FCC Rules. These are designed to provide reasonable protection against harmful interference in a residential installation. This equipment can radiate radio frequency energy and, if not installed and used in accordance with the instructions, may cause harmful interference to radio communications. However, there is no guarantee that interference will not occur in a particular installation. If this equipment does cause harmful interference to radio or television reception, which can be determined by turning the equipment off and on, the user is encouraged to try to correct the interference by one or more of the following measures:

- Reorient or relocate the receiving antenna.
- Increase the separation distance between the equipment and the receiver.
- If you are using the Workabout computer with a mains adapter, plug it into an outlet, which is on a different circuit from that to which the receiver is connected.

Consult an authorised Psion dealer or an experienced radio/TV technician for help.

This equipment was tested for FCC compliance under conditions that included the use of shielded cables and connectors between it and the peripherals. It is important that you use shielded cable and connectors to reduce the possibility of causing Radio and Television interference. Shielded cables, suitable for the Workabout, can be obtained from an authorised Psion dealer. If the user modifies the Workabout or the Multiple Docking Station, and Psion does not approve these modifications, the FCC may withdraw the user's right to operate the equipment. For customers in the USA, the following booklet prepared by the Federal Communications Commission may be of help: "How to Identify and Resolve Radio-TV Interference Problems". This booklet is available from the US Government Printing Office, Washington, DC 20402 - Stock No: 004-000-00345-4.

\*

---

## Table of Contents

<b>Introduction</b> .....	<b>1</b>
<b>Part Number Information</b> .....	<b>2</b>
<b>Serial Number Information</b> .....	<b>3</b>
<b>Troubleshooting Guide</b> .....	<b>4</b>
<b>Exploded View - General Assembly</b> .....	<b>7</b>
<b>Exploded View - Chassis Assembly</b> .....	<b>9</b>
<b>Exploded View - Drawer Assembly</b> .....	<b>10</b>
<b>Spares Kits</b> .....	<b>11</b>
<b>Dismantling the Workabout</b> .....	<b>11</b>
Tools Required.....	11
Dismantling Procedure .....	11
Dismantling the Chassis Assembly .....	12
Dismantling the Drawer Assembly .....	14
<b>Selecting the PCB Type</b> .....	<b>15</b>
<b>Re-assembly Instructions</b> .....	<b>16</b>
Re-assembling the Drawer Assembly.....	16
Notes on Drawer Re-assembly .....	16
Re-assembling the Chassis Assembly.....	17
Notes on Chassis Re-assembly.....	17
Final Re-assembly .....	18
Notes on Final Re-assembly .....	18
<b>Checking the Operation of the Options</b> .....	<b>19</b>
Checking the RS232 Interface.....	19
Testing the TTL Interface.....	20
Testing the Barcode Interface.....	20
<b>Expansion Interface</b> .....	<b>21</b>
RS232 AT/TTL Serial Interfaces .....	21
RS232 AT Serial/Barcode Interfaces .....	22
<b>Circuit Description</b> .....	<b>23</b>
LIF Converter .....	23
<b>Final Test</b> .....	<b>24</b>
Equipment.....	24
Test Setup .....	24
Test Sequence .....	25
<b>RF Final Test</b> .....	<b>28</b>
Equipment.....	28
Test Setup .....	28
Test Sequence .....	28
<b>Appendix A-Workabout Expansion Option Tests</b> .....	<b>31</b>



## **Introduction**

The purpose of this service manual is to give an overview of the service procedures that may need to be performed on the Workabout by either a third party user, or a registered Psion service centre. It has been designed to be used by the service and repair technicians who have the responsibility of maintaining the products.

The Workabout uses both conventional and high-density surface mount component technology, which requires specialist-servicing techniques. We therefore recommend that repairs be carried out at *circuit board* level, rather than at *component* level. We also encourage service centres to carry a small buffer stock of replaceable parts, to allow immediate exchange, should they need to be replaced.

Although a Final Test Unit is not essential to service a Workabout, it is recommended and is described in the *Final Test* section on page 24. The Final Test Unit (Psion part no. 1828-0100-01) is used within Psion during the manufacturing process to run a final check on the assembly. When a Workabout is connected to the Test Unit via the LIF Connector, test code (the test program) is downloaded into the machine, which then automatically performs an exhaustive and modifiable series of tests on the Workabout.

This test program can be run to monitor the liquid crystal display (LCD), keyboard, drawer switch, solid-state disks (SSDs), serial channel, and piezo status. Operating, idle, and standby current consumption can also be measured. This can be very valuable when investigating or diagnosing a reported problem. Also, once a repair has been completed, a full test can be run to ensure that the repair has been done correctly and that no other fault has been introduced.

☞ Note: - *The information in this document is confidential and should therefore only be released under a non-disclosure agreement.*

## Part Number Information

The part numbers referred to throughout this manual typically do not show the revision suffix. Consequently, refer to your Psion distributor for information on the latest revision of a specific part.

The format of the part numbers issued by Psion Industrial is as follows:

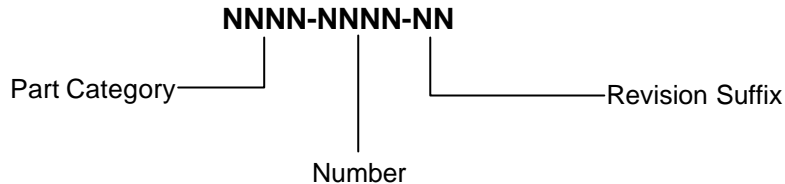

## Serial Number Information

Each Workabout has a unique serial number that includes codes for the year and week it was manufactured. The serial number can therefore be used to determine whether a Workabout is still within its warranty period.

The serial number is located on a label on the Drawer Assembly. It has the following format:

The letter M - **generic code for the MX**  
The letter R - **generic code for the RF.**

1 letter - used for manufacturing purposes.

1 letter - **variant** (see table below).

1 letter - **product type.**

A = alphanumeric keypad

B = numeric keypad

C = future variant

1 number - **year of manufacture.**

1 = 1993

2 = 1994

...

9 = 2001

2 numbers - **week of manufacture.**

01 = first week in January

52 = last week in December

4 numbers - **unique identifier.**

0001 = first product of its type to be produced in a week

9999 = 9999<sup>th</sup> product of the same type to be produced in the same week

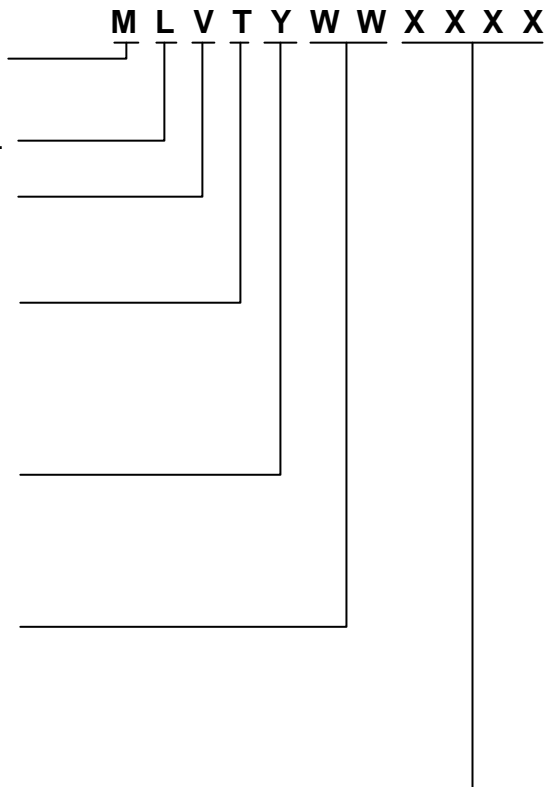



The tables below lists the variant code for Workabout MX variants that are expected to be shipping within a few months of product launch. Further codes will be released along with new variants.

**MX TABLE**

Code	Option ports fitted	
	Top option ports	Bottom option port
A	-	-
B	TTL & RS232	-
C	BCR & RS232	-
D	TTL & IrDA	RS232
E	Wand	RS232
F	Scanner	RS232
G	IrDA	IrDA
H	TTL & RS232	IrDA
I	CCD Scanner	RS232
J	TTL & IrDA	IrDA
K	Wand	IrDA
L	Scanner	IrDA
M	CCD Scanner	IrDA
N	BCR & RS232	IrDA
O	BCR & IrDA	RS232
P	BCR & IrDA	-
Q	TTL & IrDA	-
R	IrDA	-
S	-	IrDA
T	-	RS232
U	RF ID	RS232
V	RF ID	IrDA
W	-	-
X	-	-
Y	-	-
Z	-	-

## **Troubleshooting Guide**

<b>Fault</b>	<b>Cause</b>	<b>Cure</b>
Machine fails to boot up.	<ol style="list-style-type: none"> <li>1 Discharged/faulty batteries.</li> <li>2 Main PCB fault.</li> <li>3 Fuse faulty.</li> <li>4 Battery contact fault.</li> </ol>	<ol style="list-style-type: none"> <li>1 Replace alkalines/replace or recharge Nicad pack.</li> <li>2 Remove internals from machine and check Main Power Flexi ZIF Connector.</li> <li>3 Remove fuse. Check and replace if necessary.</li> <li>4 Check for continuity of battery contacts/Main Flexi using multimeter. Replace if necessary.</li> </ol>
Lines on LCD.	<ol style="list-style-type: none"> <li>1 LCD damaged.</li> <li>2 LCD ZIF open.</li> <li>3 Main PCB problem.</li> </ol>	<ol style="list-style-type: none"> <li>1 Replace LCD.</li> <li>2 Dismantle machine until Chassis Assembly is exposed, close ZIF, reassemble.</li> <li>3 Follow <i>Dismantling the Workabout</i> to remove and replace Main PCB. Return faulty PCB to Psion.</li> </ol>
Blue portions on LCD.	<ol style="list-style-type: none"> <li>1 LCD damaged.</li> <li>2 LCD ZIF open.</li> <li>3 Main PCB problem.</li> </ol>	<ol style="list-style-type: none"> <li>1 Replace LCD.</li> <li>2 Dismantle machine until Chassis Assembly is exposed, close ZIF, reassemble.</li> <li>3 Follow <i>Dismantling the Workabout</i> to remove and replace Main PCB. Return faulty PCB to Psion.</li> </ol>
Cracks on LCD.	LCD glass broken.	Replace LCD.
Workabout has problems with LIF communications.	Main PCB problem.	Follow <i>Dismantling the Workabout</i> to remove and replace Main PCB. Return faulty PCB to Psion.
Workabout has problems reading SSDs.	<ol style="list-style-type: none"> <li>1 Warped Connector Block Arm.</li> <li>2 Main FFC faulty.</li> <li>3 Door switch on Main PCB damaged.</li> </ol>	<ol style="list-style-type: none"> <li>1 Dismantle machine, remove and replace Connector Block.</li> <li>2 Replace Drawer Assembly.</li> <li>3 Follow <i>Dismantling the Workabout</i> to remove and replace Main PCB. Return faulty PCB to Psion.</li> </ol>
No top port communications possible.	<ol style="list-style-type: none"> <li>1 Damaged expansion FFC.</li> <li>2 Warped Connector Block Arm.</li> <li>3 Loose ZIF connector.</li> <li>4 Door switch on Main PCB damaged.</li> </ol>	<ol style="list-style-type: none"> <li>1 Replace Drawer Assembly.</li> <li>2 Dismantle machine, remove and replace Connector Block.</li> <li>3 Remove outer case of machine, relocate Expansion Flexi and close ZIF.</li> <li>4 Follow <i>Dismantling the Workabout</i> to remove and replace Main PCB. Return faulty PCB to Psion.</li> </ol>
No infrared communications.	<ol style="list-style-type: none"> <li>1 Top port damaged.</li> <li>2 Bottom port damaged.</li> </ol>	<ol style="list-style-type: none"> <li>1 Replace Drawer Assembly.</li> <li>2 Replace bottom infrared port flexi-connector.</li> </ol>

Fault	Cause	Cure
No TTL communications possible.	<ol style="list-style-type: none"> <li>1 Damaged expansion FFC.</li> <li>2 Warped Connector Block Arm.</li> <li>3 Loose ZIF connector.</li> <li>4 Door switch on Main PCB damaged.</li> </ol>	<ol style="list-style-type: none"> <li>1 Replace Drawer Assembly.</li> <li>2 Dismantle machine, remove and replace Connector Block.</li> <li>3 Remove outer case of machine, relocate Option Flexi and close ZIF.</li> <li>4 Follow <i>Dismantling the Workabout</i> to remove and replace Main PCB. Return faulty PCB to Psion.</li> </ol>
No Bar Code communications possible.	<ol style="list-style-type: none"> <li>1 Damaged expansion FFC.</li> <li>2 Warped Connector Block Arm.</li> <li>3 Loose ZIF connector.</li> <li>4 Door switch on Main PCB damaged.</li> </ol>	<ol style="list-style-type: none"> <li>1 Replace Drawer Assembly.</li> <li>2 Dismantle machine, remove and replace Connector Block.</li> <li>3 Remove outer case of machine, relocate Expansion Flexi and close ZIF.</li> <li>4 Follow <i>Dismantling the Workabout</i> to remove and replace Main PCB. Return faulty PCB to Psion.</li> </ol>
Outer case/ key mat/window damaged.	User damage.	Remove the outer case assembly and replace. Make sure the labels on the new case match the labels on the old case.
Drawer cannot be closed.	<ol style="list-style-type: none"> <li>1 Drawer derailed.</li> <li>2 Mechanical interference.</li> <li>3 Drawer lock damaged.</li> </ol>	<ol style="list-style-type: none"> <li>1 Refit Drawer.</li> <li>2 Remove case from machine. Check for obstructions and interference caused by misplaced/ill-fitting batteries, battery contacts, SSDs, Flexi's, PCBs, seals, etc.</li> <li>3 Replace outer case.</li> </ol>
Drawer not opening when release button is pressed.	<ol style="list-style-type: none"> <li>1 Drawer derailed.</li> <li>2 Release button damaged.</li> <li>3 Mechanical interference.</li> <li>4 Drawer Spring missing.</li> </ol>	<ol style="list-style-type: none"> <li>1 Refit Drawer.</li> <li>2 Replace outer case or Drawer Assembly.</li> <li>3 Remove case from machine. Check for obstructions and interference caused by misplaced/ill-fitting batteries, battery contacts, SSDs, Flexi's, PCBs, seals, etc.</li> <li>4 Replace Drawer Spring.</li> </ol>
Drawer will not stay closed.	<ol style="list-style-type: none"> <li>1 Mechanical interference.</li> <li>2 Drawer lock damaged.</li> </ol>	<ol style="list-style-type: none"> <li>1 Remove case from machine. Check for obstructions and interference caused by misplaced/ill-fitting batteries, battery contacts, SSDs, Flexi's, PCBs, seals, etc.</li> <li>2 Replace outer case or Drawer Assembly.</li> </ol>
Alphanumeric keys not working.	<ol style="list-style-type: none"> <li>1 Damaged key mat.</li> <li>2 Defective Main PCB.</li> </ol>	<ol style="list-style-type: none"> <li>1 Replace case.</li> <li>2 Replace Main PCB.</li> </ol>
Nicad pack fails to charge.	<ol style="list-style-type: none"> <li>1 Central contact not connecting.</li> <li>2 Battery contacts damaged.</li> <li>3 Nicad pack damaged.</li> <li>4 Charger problems.</li> </ol>	<ol style="list-style-type: none"> <li>1 Replace Drawer Assembly.</li> <li>2 Replace Drawer Assembly.</li> <li>3 Replace Nicad pack.</li> <li>4 Consult <i>Docking Station Service Manual</i> Psion p/no: 6104-0004-01.</li> </ol>
Machine switches off when operated.	Main Power FFC damaged.	Replace Drawer Assembly.
Backlight does not work.	<ol style="list-style-type: none"> <li>1 Backlight damaged.</li> <li>2 Main PCB problem.</li> </ol>	<ol style="list-style-type: none"> <li>1 Replace backlight.</li> <li>2 Replace Main PCB.</li> </ol>

---

<b>Fault</b>	<b>Cause</b>	<b>Cure</b>
Backlight is dim.	Backlight worn. Approximate time to 50% brightness is 500 hours.	Replace backlight.

## **Exploded View - General Assembly**

The following illustration shows the general assembly, dismantled into replaceable subassemblies and components.

Note that the numbered circles in the illustration correspond to the items in the REF. column of Table 1.

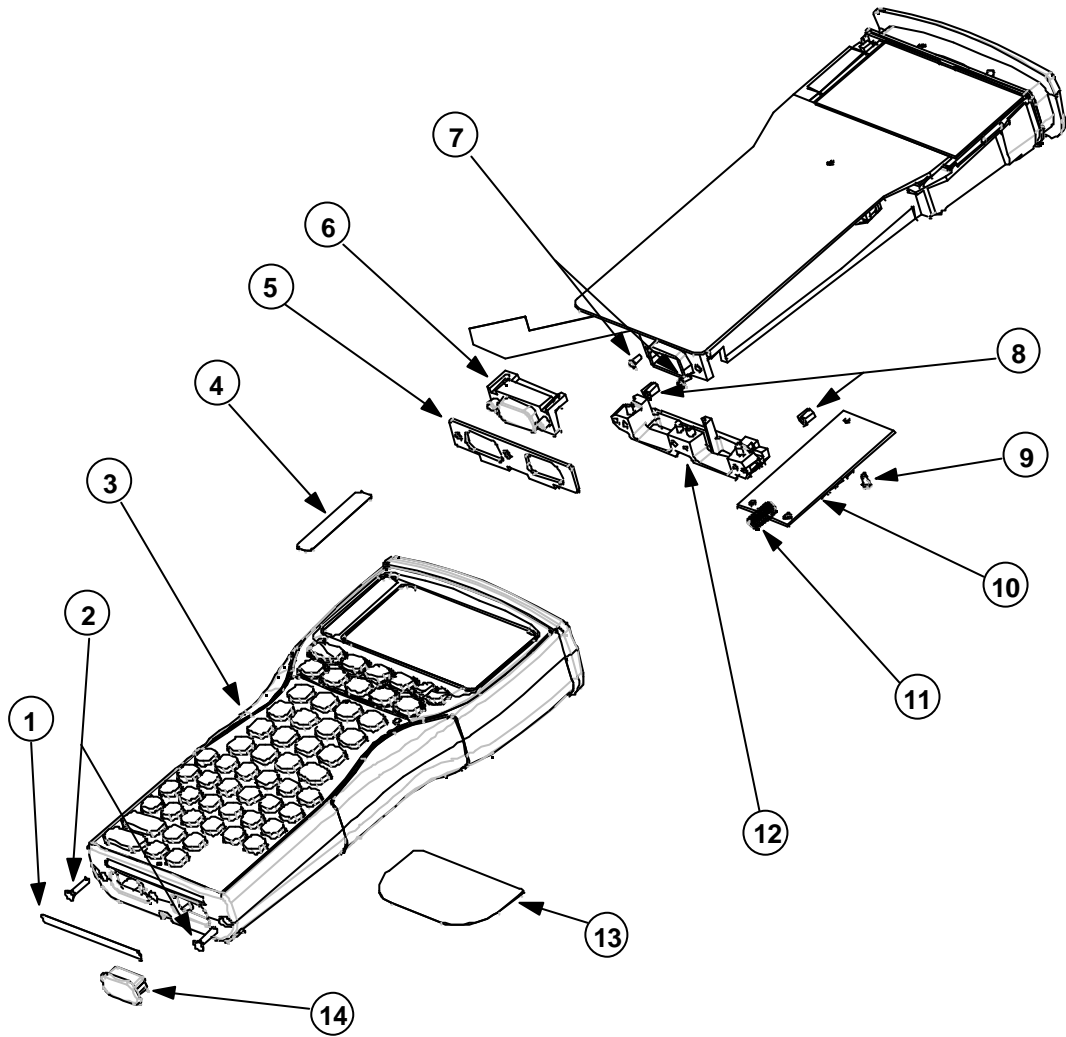

**Table 1**

<b>REF.</b>	<b>DESCRIPTION</b>	<b>QTY</b>
1	LBL BOTTOM	1
	LBL BTM RS232/LIF	1
	LBL BTM IRDA/LIF	1
2	SCREW M2.5x10MM POZ.CS	2
3	MX ALPHA CASE + LATCH	1
	MX NUMERIC CASE + LATCH	1
	MX SCANNER CASE + LATCH	1
	MX SCANNER NUMERIC CASE + LATCH	1
4	LBL MX 2MB MEMORY	1
5	BOTTOM SEAL	1
6	MLDG D-TYPE BLANK	1
	MX BTM FLEXI IRDA	1
	MX BTM FLEXI RS232	1
7	SCREW M2x4MM PANHEAD BLACK	2
8	NUTSERTS	2
9	SCREW M2x4MM PANHEAD BLACK	2
10	EXPANSION PCB (Barcode/Wand)	1
	DECODER PCB (Scanner)	1
	DECODER PCB SUPPORT MOULDING (Scanner)	1
11	DRAWER SPRING	1
12	CONNECTOR BLOCK	1
13	LBL MX REAR CASE	1
	LBL MX SCANNER REAR	1
14	LIF DUST COVER	1

## **Exploded View - Chassis Assembly**

The following illustration shows the chassis assembly, dismantled into replaceable subassemblies and components.

Note that the numbered circles in the illustration correspond to the items in the REF. column of Table 2.

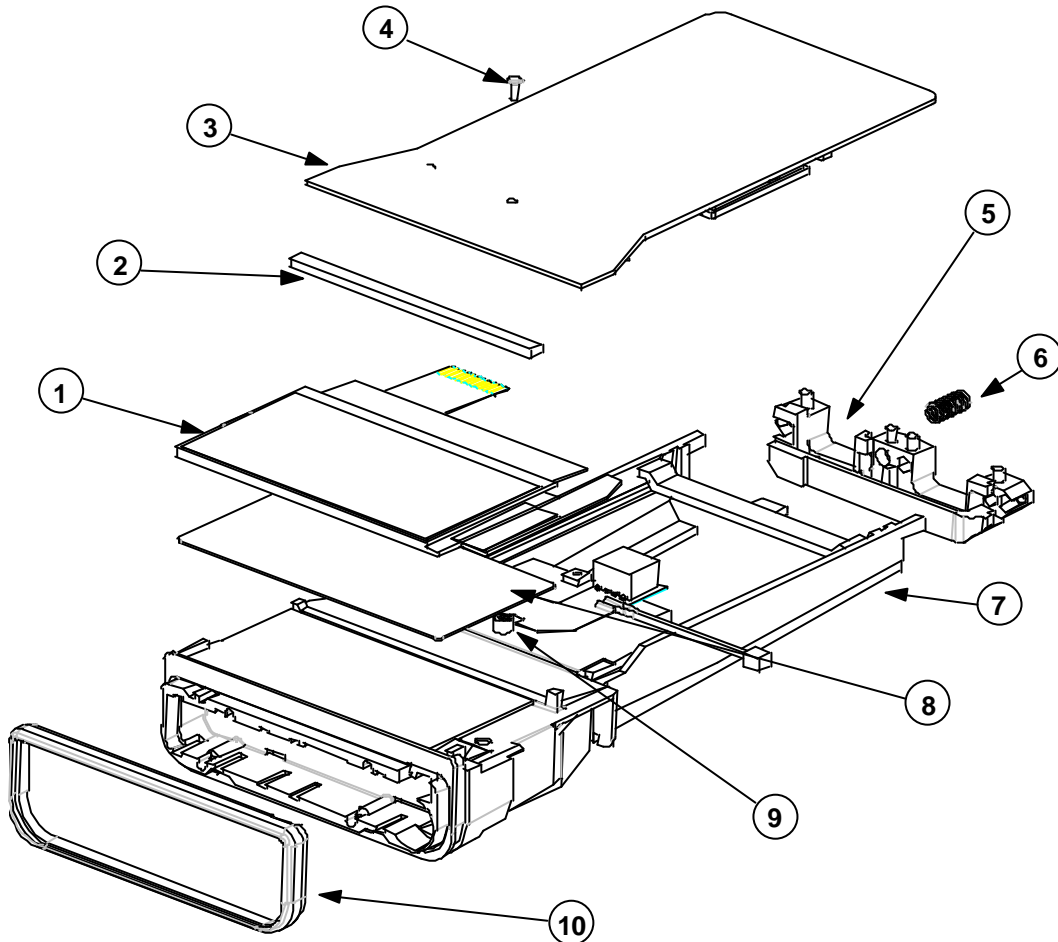

**Table 2**

REF.	DESCRIPTION	QTY
1	LCD MODULE (240x100)	1
2	FOAM LCD SUPPORT	1
3	MX PCB 2MB	1
4	SCREW M2x4MM PANHEAD BLACK	1
5	CONNECTOR BLOCK	1
6	DRAWER SPRING	1
7	CPU FRAME	1
8	LCD BACKLIGHT	1
9	LCD SLEEVE	1
10	CHASSIS SEAL	1

## **Exploded View - Drawer Assembly**

The following illustration shows the Drawer Assembly, dismantled into subassemblies and components.

☞ Note: - The Drawer Assembly is normally replaced as a complete kit (see Spares Kits on page 11). It is therefore not necessary to dismantle the Drawer Assembly. This illustration is included for information purposes only.

Note that the numbered circles in the illustration correspond to the items in the REF. column of Table 3.

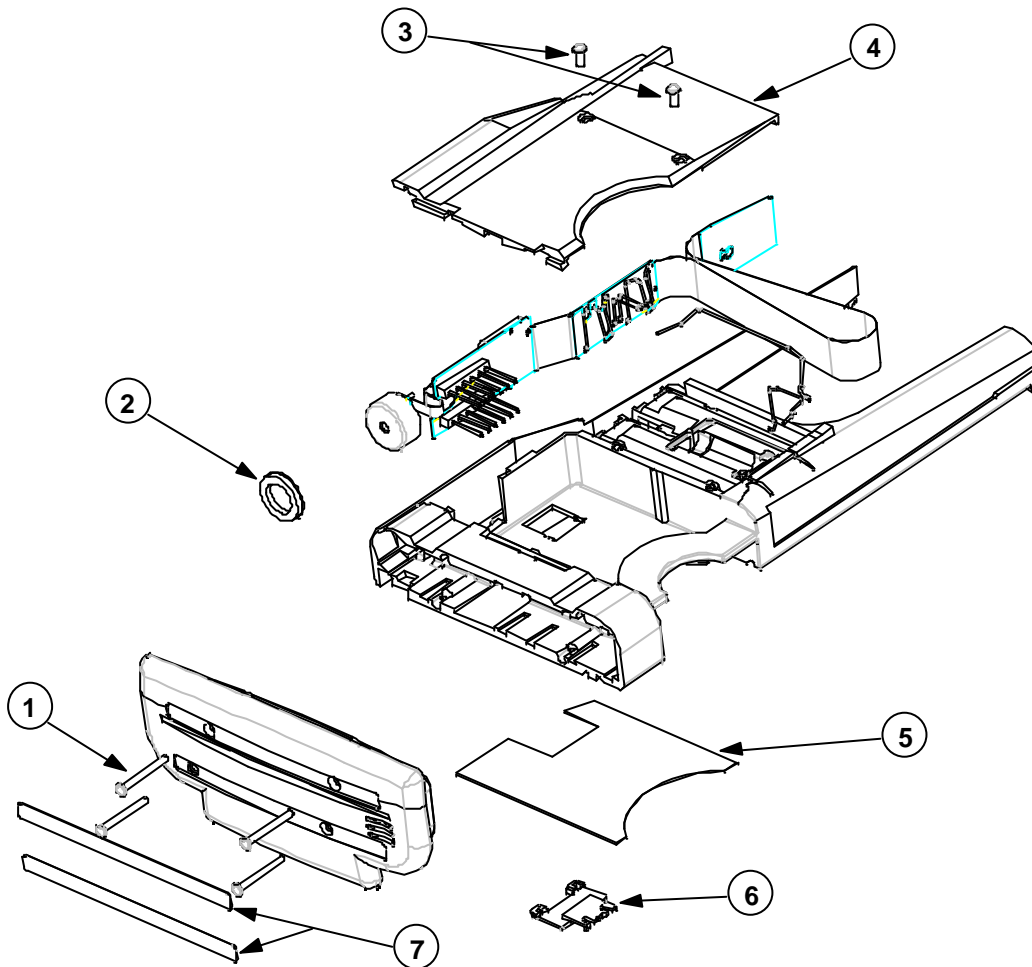

**Table 3**

REF.	DESCRIPTION	QTY
1	SCREW M2x16MM TOP CAP	4
2	FOAM PIEZO SEAL	1
3	SCREW M2x4MM PANHEAD BLACK	2
4	SSD BACK	1
5	BATTERY CONFIGURATION LABEL	1
6	LITHIUM BATTERY DOOR	1
7	TOP CAP LABEL - BLANK	2



## **Spares Kits**

Please refer to the latest spares list, held on the web site, for current information.

## **Dismantling the Workabout**

The modular design of the Workabout is such that the internal workings of the product can be removed from the case by removing two screws. This means that if the outer case assembly becomes damaged, it can be replaced quickly and easily without the need to change any other component. If there is a fault in the Outer Case Moulding, LCD Window, Keyboard Frame, or Rubber Key mat, the entire case should be replaced.

☞ Note: - In some cases the machine may be fitted with security screws that require a suitable screwdriver to remove them.

When you remove internal components from the case, take care not to damage the LCD Module. Do not bend the Module, as it is prone to fracturing. Do not touch the LCD Glass, as it will show finger marks and smudges.



If the LCD glass is broken, be careful not to get any liquid in your mouth or eyes. In the event of any liquid crystal getting on skin or clothes, wash it off immediately with soap and plenty of water and seek a doctor's advice.

## **Tools Required**

<b>Tool</b>	<b>Description</b>	<b>Type</b>
Crosshead Screwdriver	Pozi	Size - 0
Crosshead Screwdriver	Phillips	Size - 00
Screwdriver	Flat	Size - 2.5mm
Nut Spinner	n/a	4mm AF
Knife/Scalpel	n/a	n/a
Pliers	Snipe nose	n/a

## **Dismantling Procedure**

- 1 Press the drawer release button (or use a security key if necessary) and open the Workabout.
- 2 Remove any batteries (including the Lithium Dry Cell) and SSDs that are inside the Workabout.
- 3 Remove the fuse from its location beneath the main batteries. If the fuse is damaged, replace it with a 1.25 AMP 'Fast Blow' glass fuse, 5mm Ø, 20mm long, Psion part number A4900-0041.
- 4 Remove the 2 screws from the base of the Workabout.
- 5 Pull the Chassis Assembly from the case (this may require a sharp tug).
- 6 If fitted, unclip the Option Flexi from its ZIF Connector on the Main PCB and also from the ZIF Connector(s) on the Expansion or Monitor PCB.

☞ Note: - Take care not to crease or tear the Flexi.

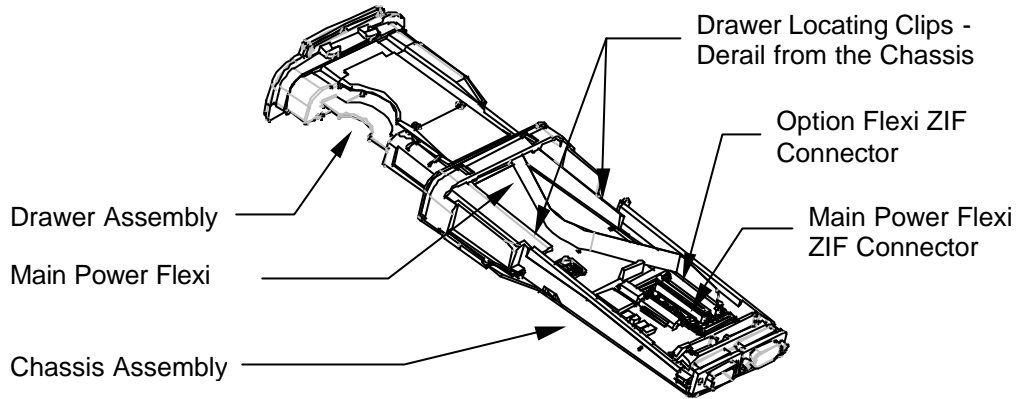

- 7 Unclip the Main Power Flexi from its ZIF Connector.
- 8 Unclip the Drawer Assembly by derailing the Drawer from its tracks.
- 9 Slide the Drawer Assembly out of the Chassis Assembly.

☞ Note: - *Dismantling the Latch Assembly is not necessary as replacement cases are supplied complete with latches. The following step is for information only.*

- 10 To remove the Latch Assembly, remove the 3 screws from the latch case. Be careful to catch the internal springs and other components when you remove the case.

### **Dismantling the Chassis Assembly**

- 1 Remove the Drawer Spring from the Connector Block.

☞ Note: - *The Drawer Spring should always be removed when you either remove or refit the Connector Block.*

- 2 Remove the Bottom Connector Seal.

☞ Note: - *As a general rule, replace the Bottom Connector Seal whenever it is removed for servicing.*

- 3 Remove the 2 screws from the LIF Connector.

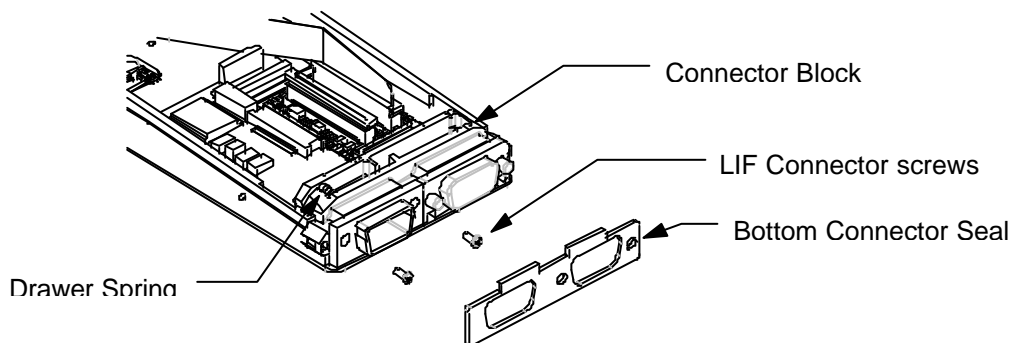

- 4 Remove the screw-locks for the Expansion Board D-Type Connector, if fitted.
- 5 Lift out the Connector Block by squeezing its arm in as near as possible to the base of the Workabout, to allow the actuator to clear the retaining tab on the CPU frame.

**6** If fitted, remove the Decoder or Expansion PCB:

- a) On a Scanner Workabout, remove the Flexi's from the ZIF connectors and then remove the 2 retaining screws on the Support Moulding.
- b) On a Barcode/Wand Workabout, remove the Flexi from the ZIF connector and then remove the 2 retaining screws.

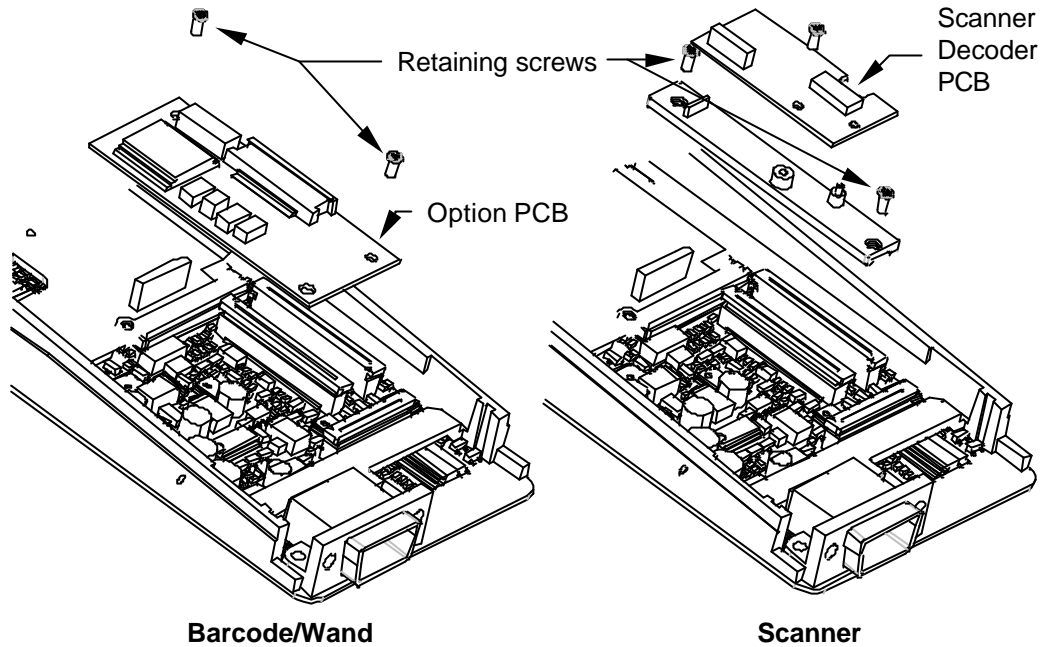

**7** Remove the Option Port FFC, if fitted, and remove the Option Port.

**8** Remove the LCD Backlight Power Connector, if fitted.

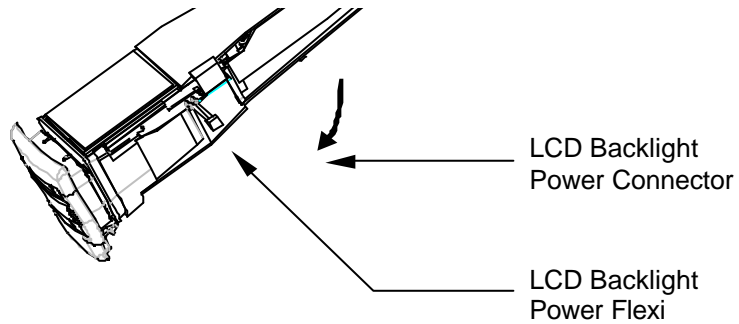

- 9 Unclip the LCD ZIF from the Main PCB. There is a hole in the CPU frame moulding to allow you to do this.

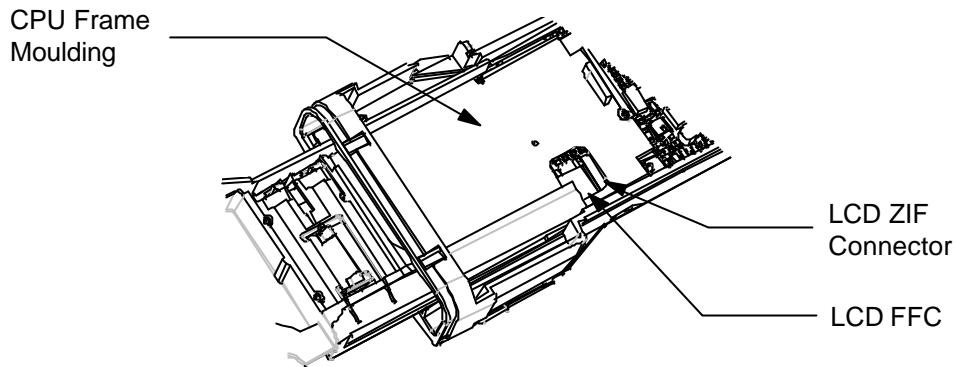

- 10 Remove the Main PCB Screw.
- 11 Remove the Main PCB.
- 12 Remove the Chassis Seal.
- 13 Remove the LCD. The LCD Module is located on a pin on the CPU Frame moulding. The rubber LCD Sleeve covers this pin. Handle the LCD Module by the glass so that you do not damage the circuit boards. Manoeuvre the module off the pin by wiggling the module while holding the glass.
- 14 Remove the Backlight, if fitted.

The Chassis Assembly is now dismantled.

### ***Dismantling the Drawer Assembly***

*Note: - It is not necessary to dismantle the Drawer Assembly. This procedure is included for information purposes only.*

- 1 Remove the Top Cap:
  - a) On base machines, labels cover the four screws that secure the Top Cap. Remove the labels and then remove the screws.
  - b) On Option Machines, the screws are not covered.

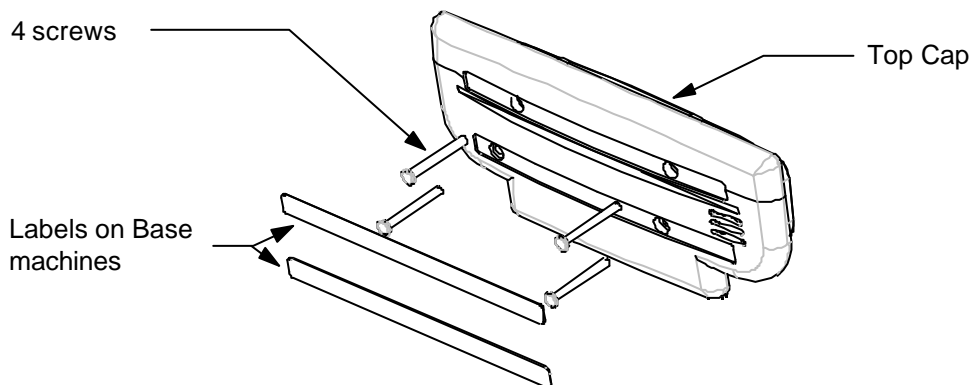

- 2 Remove the foam Top Cap Seal and the Piezo Seal.

☞ Note: - As a general rule, replace the Top Cap Seal and Piezo Seal whenever they are removed for servicing.

- 3 Remove the Expansion FFC if fitted. Ease the FFC out of the case by sliding it backwards and forwards length-ways and pulling it gently up out of the insertion slot in the SSD Drawer moulding.
- 4 Remove the SSD Back. This is clipped onto the SSD Drawer at the top end. To remove it:
  - a) Remove the two securing screws.
  - b) Remove the SSD Back by lifting its free end out by about 10mm and then prying the top left-hand corner away from the SSD Drawer moulding until it becomes unclipped. Take care not to damage the Lithium Battery Contacts on the FFC.
- 5 Release the Piezo. The tail that connects the Piezo to the Main Power FFC is quite thin and can be damaged if not handled correctly. Take care to release the strip of the FFC attached to the Piezo at the same time that the rest of the Main Power FFC assembly is eased out of the SSD Drawer.
- 6 Remove the Fuse Contacts.

The Drawer Assembly is now fully dismantled.

## **Selecting the PCB Type**

The Workabout Main PCB can be programmed for Scanner, Integral Wand, or Numeric versions by using a Workabout Final Test Box.

The Main PCB is supplied programmed as Type B (Top port - TTL & RS232) and the Workabout Final Test Box allows you to select the PCB type using the product type/variant code as listed in the section *Serial Number Information* on page 2.

## Re-assembly Instructions

The Workabout can be re-assembled by following the flow diagrams below.

The flow diagrams show the correct sequence for re-assembling the subassemblies. Also refer to the diagrams in the *Dismantling Procedure* steps on page 11, in reverse order, as you perform each re-assembly step.



Take care when you reinsert Flexi's into ZIF Connectors. If you insert Flexi's into the connectors at an angle, it can cause open or short-circuits.

Make sure that the bends in the Flexi's allow the drawer to open and close correctly.

### **Re-assembling the Drawer Assembly**

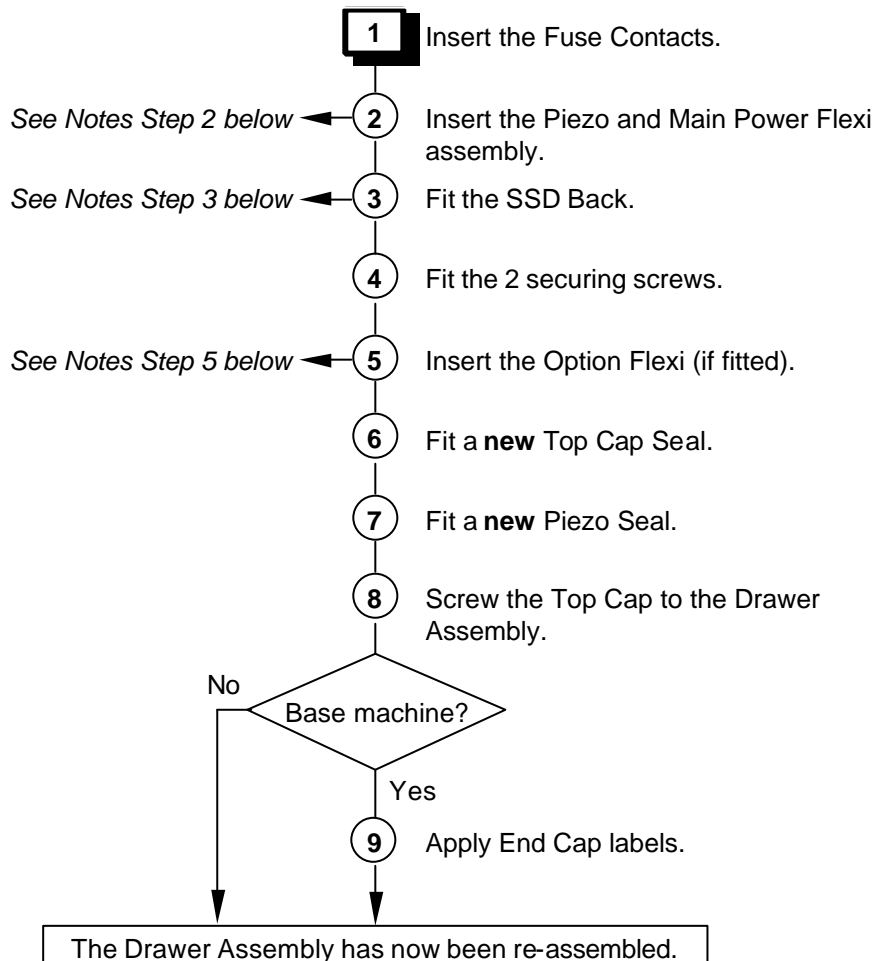

### **Notes on Drawer Re-assembly**

#### **Step 2**

Take care when sliding the Piezo tail into the SSD Drawer via the insertion slot.

---

### Step 3

Take care not to damage the Main Battery and Lithium Battery contacts.

### Step 5

Ease the FFC into the case by sliding it backwards and forwards while pushing it gently down through the insertion slot in the SSD Drawer moulding.

## Re-assembling the Chassis Assembly

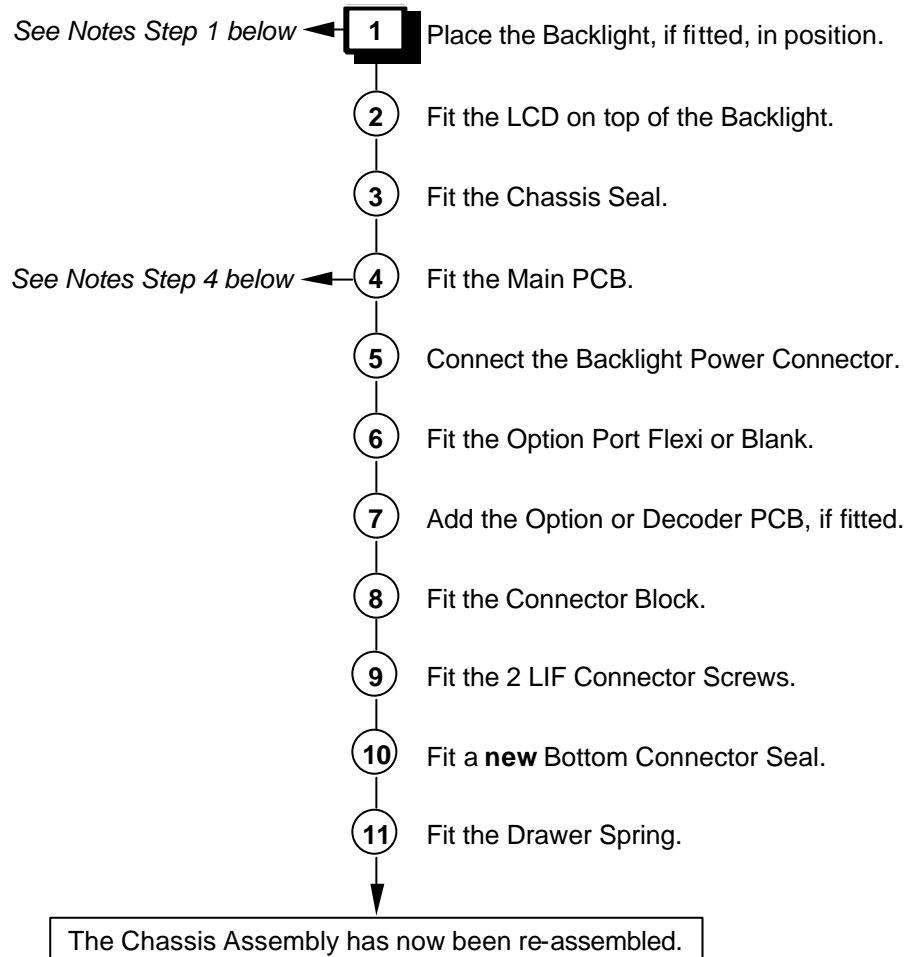

## Notes on Chassis Re-assembly

### Step 1

Stick the LCD Backlight Flexi to the side of the Chassis Assembly.

### Step 4

Hold the Main PCB and Chassis Assembly parallel to each other and insert the LCD Flexi into the LCD ZIF Connector. Lock the ZIF Connector. Now fit the Main PCB Screw.

## Final Re-assembly

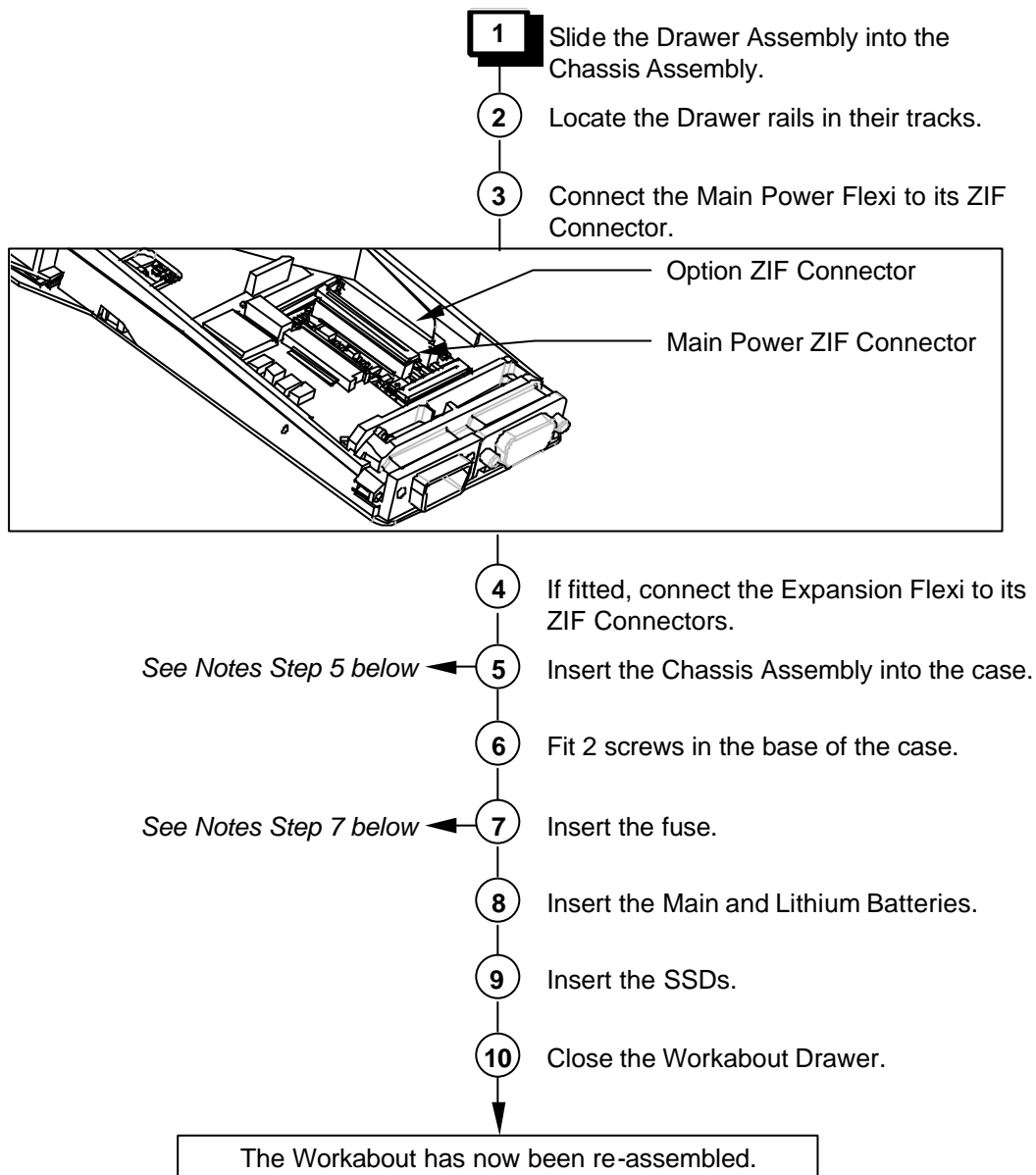

### Notes on Final Re-assembly

#### Step 5

Take care to ensure that the Chassis Seal fits correctly.

#### Step 7

The fuse must be a 1.25 AMP 'Fast Blow' glass fuse, 5mm Ø, 20mm long, Psion part number A4900-0041.



## Checking the Operation of the Options

To accurately check the operation of fitted options, you need the following items:

- A bar code reader or a scanner that gives a TTL output.
- An RS232 interface.
- A bar code wand or scanner with a 9-way male connector with the following pin arrangement:

Pin No.	Signal Name	Remarks
1	DCD	Handshake - input
2	RX	Bar Code Data Receive - input
3	GND	0V
4	GND	0V
5	DSR	Handshake - input
6	DTR	Handshake (Trigger or Enable) - output
7	GND	0V
8	GND	0V
9	VCCEXT	5V 200mA max

- An IBM-compatible PC able to run VT in MS-DOS or Terminal in Windows 3.1x. Any other program that can be run to provide Glass Terminal Emulation can also be used.

### Checking the RS232 Interface

You can use the **Comms** application on the Workabout to turn on the RS232 interface on the option board and check the RS232 interface. To check the RS232 interface:



- 1 Switch on the Workabout.

Switching the machine on after replacing a backup battery, or for the first time, causes the Workabout to reboot. When you press the On button, the Workabout beeps and after a pause of up to 5 seconds, the shell screen appears.

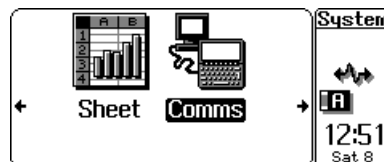
- 2 Press the **Menu** key.
- 3 Use the cursor keys to select the **System screen** option and press **Enter**.



- 4 On the System screen, use the cursor keys to position the highlight bar over the **Comms** application and press **Enter**.
- 5 Plug a 9-way female to 9-way female null modem cable between the serial port on the PC and the RS232 port on the Workabout.
- 6 On the PC, run VT in MS-DOS, or Terminal in Windows 3.1x. The default baud rate for the RS232 port in the Workabout is 9600. Adjust the settings on the PC program to match.

- 7 When a serial link has been established between the PC and the Workabout, any characters you type on the Workabout appear on the PC screen and vice-versa. This indicates that the RS232 serial channel is working correctly.
- 8 To exist from the **Comms** program, press  +  on the Workabout.

### Testing the TTL Interface

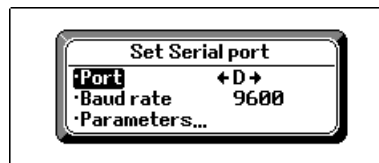
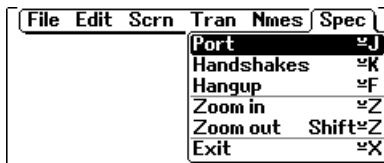

You can test the TTL interface by using a compatible barcode device. To do this, follow steps 1 to 4 of the RS232 Interface check procedure and then follow the steps below:

- 1 Plug a compatible barcode device into the TTL port.
- 2 If the barcode device is giving true data, set the expansion board port to D. If it is giving inverted data, set the port to G:
  - a) In the **Comms** application, press **Menu** and select **Spec**. (Use the ↑ and ↓ keys to select an item and the ← and → keys to select a value.)
  - b) Set the baud rate to 9600 and the port to D or G as appropriate.





- 3 Scan some sample bar codes. The numerical equivalent of the barcode should appear in the top left corner of the screen.

☞ Note: - Always scan at least two different barcodes to ensure that a chance operation has not occurred.

- 4 To exist from the **Comms** program, press  +  on the Workabout.

### Testing the Barcode Interface

The Barcode interface can be tested using a compatible barcode wand or scanner. To do this, follow steps 1 to 4 of the RS232 Interface check procedure and then follow the steps below:

- 1 Plug a compatible barcode device into the Barcode port.
- 2 Set the expansion board port to E and set the baud rate to 9600 (refer to the *Testing the TTL Interface* instructions).
- 3 Scan some sample bar codes. The numerical equivalent of the barcode should appear in the top left corner of the screen.
- 4 To exist from the **Comms** program, press  +  on the Workabout.

## **Expansion Interface**

The interfaces built into the Workabout are accessible by plugging in appropriate connectors or adapters at the top or bottom of the unit.

The top connectors provide RS232 AT and either a TTL-level serial interface or a bar code wand interface. The TTL-level serial interface can operate CCD barcode scanners or low power laser scanners.

The bottom connector provides access to the LIF connector for the docking interface, external power and SIBO serial interfaces.

Optional internal peripheral modules provide the serial and barcode interfaces. These are fitted inside the Workabout and plug into an internal expansion connector.

### **RS232 AT/TTL Serial Interfaces**

These are provided by the RS232 AT/TTL peripheral module, which provides:

- An IBM-compatible RS232 AT serial interface at standard RS232 voltage levels
- An RS232 TTL serial interface at 5V TTL levels
- A 5V nominal (4.7V min.) software switched power supply (VCCEXT) which provides up to 200 mA, with a current limit at approximately 250mA

The serial format and the polarity of the TTL-level interface can be programmed using suitable software programs. The interfaces can be operated at a baud rate of 19,200.

☞ Note: - *Although both interfaces are present in the module, only one can be configured as operational at any one time.*

The 9-way D-type male RS232 AT interface connector pin allocation is shown below:

Pin No.	Signal Name	Remarks
1	DCD	Handshake - input
2	RX	Serial Receive - input
3	TX	Serial Transmit - output
4	DTR	Handshake - output
5	GND	0V
6	DSR	Handshake - input and EXON <sup>(1)</sup>
7	RTS	Handshake - output
8	CTS	Handshake - input
9	GND	0V

(1) The EXON signal is the external wake-up control for the Workabout. If the RS232 AT/TTL peripheral expansion module is configured correctly, the EXON signal switches on the Workabout when an RS232 or TTL-level rising edge is applied to this signal. The RS232 AT interface is enabled by opening port A (see *Testing the TTL Interface* on page 20 for instructions on how to do this).

The 9-way D-type female RS232 AT interface connector pin allocation is shown below:

Pin No.	Signal Name	Remarks
1	GND	0V
2	RX	Serial Receive - input
3	TX	Serial Transmit - output
4	VCCEXT	5V 200mA max <sup>(1)</sup>
5	GND	0V
6	DSR	Handshake - input
7	RTS	Handshake - output
8	CTS	Handshake - input
9	GND	0V

(1) The VCCEXT supply is switched on and off at the same time as the TTL serial port is opened and closed. The RS232 TTL interface is enabled by opening port D for true data and port G for inverted data (see *Testing the TTL Interface* on page 20 for instructions on how to do this).

### **RS232 AT Serial/Barcode Interfaces**

These are provided by the RS232 AT/Barcode peripheral module, which provides:

- An IBM-compatible RS232 AT serial interface at standard RS232 voltage levels at up to 19,200 baud
- An RS232 TTL serial interface at 5V TTL levels
- A 5V nominal (4.7V min.) software switched power supply (VCCEXT) which provides up to 200 mA, with a current limit at approximately 250mA
- A barcode wand interface with a 5V nominal (4.7V min.) software switched power supply (VCCEXT) which provides up to 200 mA

The RS232 AT interface serial format can be programmed using suitable software programs and a Hewlett Packard HBCR-1612 barcode decoder device provides the barcode interface. This allows wands, which generate digital signals to be connected directly to the barcode interface. The barcode interface format can be programmed using software, although this feature is not used if a Hewlett Packard barcode wand is being used, as the decoder requires a set format.

☞ Note: - *Although both interfaces are present in the module, only one can be configured as operational at any one time.*

The 9-way D-type male RS232 AT interface connector pin allocation is shown below:

Pin No.	Signal Name	Remarks
1	DCD	Handshake - input
2	RX	Serial Receive - input
3	TX	Serial Transmit - output
4	DTR	Handshake - output
5	GND	0V
6	DSR	Handshake - input and EXON <sup>(1)</sup>
7	RTS	Handshake - output
8	CTS	Handshake - input
9	GND	0V

(1) The EXON signal is the external wake-up control for the Workabout. If the RS232 AT/TTL peripheral expansion module is configured correctly, the EXON signal switches on the Workabout when an RS232 or TTL-level rising edge is applied to this signal. The RS232 AT interface is enabled by opening port B (see *Testing the TTL Interface* on page 20 for instructions on how to do this).

The 9-way D-type female RS232 AT interface connector pin allocation is shown below:

Pin No.	Signal Name	Remarks
1	DCD	Handshake - input
2	RX	Bar Code Data Receive - input
3	GND	0V
4	GND	0V
5	DSR	Handshake - input
6	DTR	Handshake (Trigger or Enable) - output
7	GND	0V
8	GND	0V
9	VCCEXT	5V 200mA max <sup>(1)</sup>

(1) The VCCEXT supply is switched on and off at the same time as the barcode port is opened and closed. The barcode interface is enabled by opening port E (see *Testing the TTL Interface* on page 20 for instructions on how to do this).

☞ Note: - The Hewlett Packard barcode decoder uses 9600 baud, true data port settings.

## **Circuit Description**

### **LIF Converter**

The LIF Converter provides the interface between the mains adaptor, serial link and the Workabout. It also includes a charging circuit in the form of a linear regulator operating in constant current mode.

## **Final Test**

The section describes how to set up the Final Test and perform the test sequence on a Workabout.

☞ Note: - Please refer to Appendix A for instructions on how to test the Workabout expansion options.

These instructions do not describe how to perform tests on the Workabout Peripheral product range.

### **Equipment**

You need the following equipment to perform the Final Test:

Qty	Description	Psion p/no.
1	Workabout Final Test Unit	1810-0001-01
1	Mains Lead	
2	Test SSDs	
1	Workabout Test Battery Cartridge	
1	LIF Cable	
1	Lithium Battery	

☞ Note: - The Final Test Unit is suitable for working with mains supplies in the range 90-130/180-260VAC @ 47-63Hz, without adjustment.

### **Test Set-up**



WARNING - There are hazardous voltages within the Final Test Unit. Please follow this procedure carefully.

Follow the steps below to set up a Workabout for testing.

**1** Insert the following items in the Workabout:

- 2 x test SSDs (MX Only)
- 1 x lithium battery
- 1 x Workabout Test Battery Cartridge

**2** On the Final Test Unit:

- a) Connect the LIF Cable and Ground Detect Probe to the Final Test Unit.
- b) Set the main battery switch to STANDBY.
- c) Set the DC Power switch to OFF.

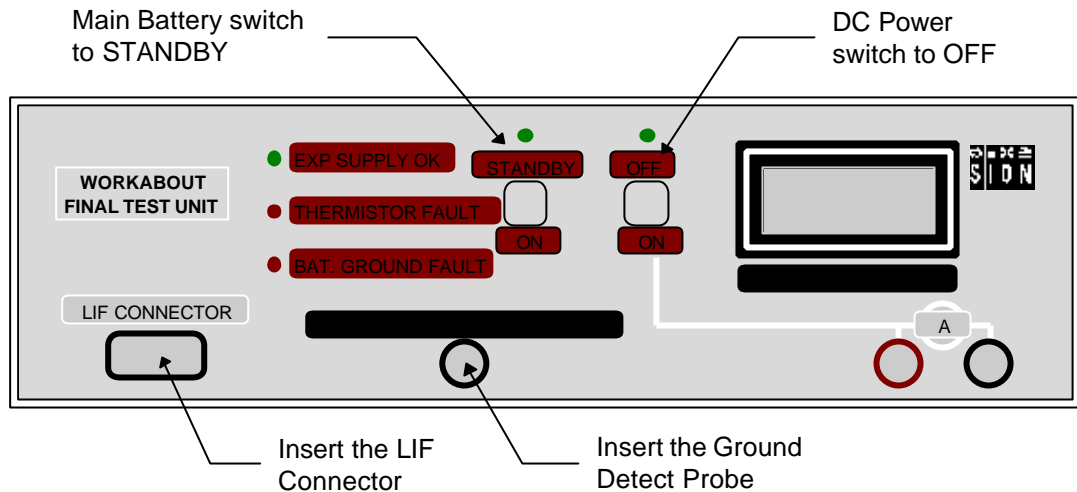

- 3 Connect the LIF Connector to the Workabout. The LIF connector provides power to the Workabout:

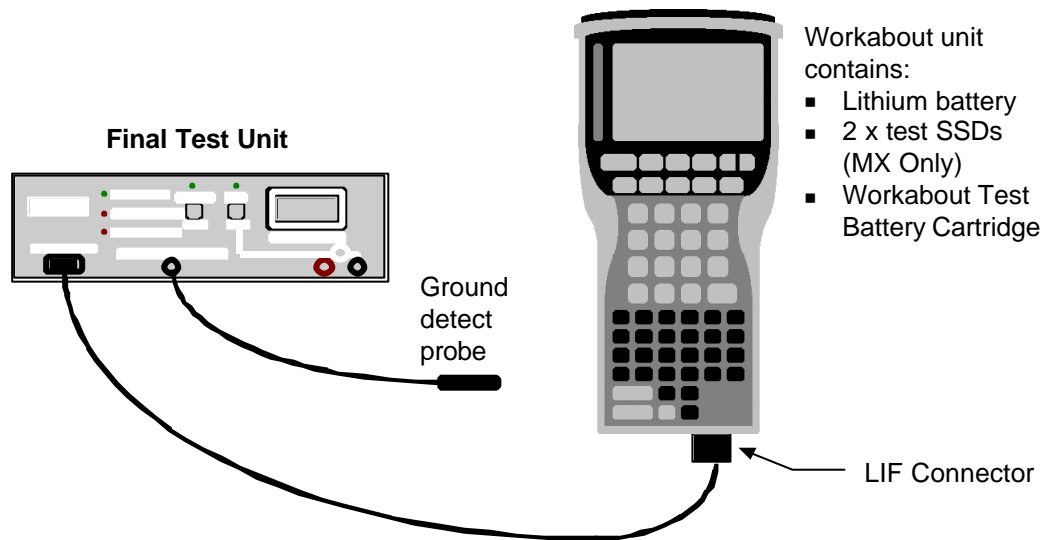

The Workabout is now ready for testing.

### Test Sequence

- 1 Check the battery standby current reading on the Final Testing Unit ammeter.  
**Fail** the 2M SR-DRAM unit if the reading is **higher** than **750mA**.
- 2 Check that the THERMISTOR FAULT lamp is **not lit**.
- 3 Move the Main Battery switch from STANDBY to ON.
- 4 The EEPROM setting will be displayed and the serial number is required to be entered. The serial number information is detailed on page 2 of this manual.
- 5 Each field should be correctly filled by using the arrow keys to select the field, and entering the existing serial number displayed on the Workabout drawer. The variant settings can be verified against the information given on page 3 of this manual.

**6** Once complete, press **MENU** to program. The Final Test Program is downloaded via the LIF cable, and the following menu is displayed on the Workabout:

<b>MENU - FINAL - MX</b> - 'Version Number' 'O/S' RAM 'size' LANG 'language'			<b>MENU - FINAL - RF</b> - 'Version Number' 'O/S' RAM 'size' LANG 'language'		
All	Lcd	Keys	All	Lcd	Keys
Cpu	Serial	Supply	Cpu	Serial	Supply
SSDs	Sound	Expansion	MMC	Sound	Expansion
Ram	Drawer		Ram	Drawer	
Arrow keys move, ENTER selects			Arrow keys move, ENTER selects		

Check the following:

- a) The Final Test Program Version Number corresponds to the latest release.
- b) Check that the Operating System version number, RAM size and Language settings are correct.
- c) Check the ammeter reading on the Final Test Unit. **Fail** the unit if the reading is **higher** than **25mA** for **MX**.

*Note: - You can perform each check individually by selecting each option in turn from the test menu. This procedure uses the **all** option to run through all the checks in one go.*

**7** Select the **All** option from the test menu on the Workabout and press **Enter**.

A bold centre cross and a corner marker are displayed. The cross should be bold and even throughout and all corners should be complete, as shown in the example below:

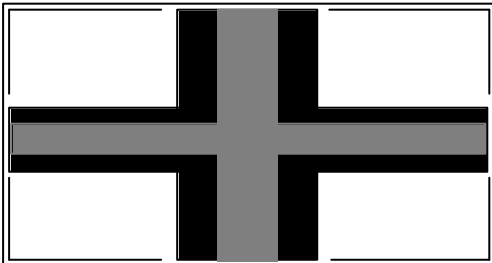

- 8** Press any key to continue.
- 9** If the pattern is correct press **Space**. If the pattern is faulty press **Esc**.
- 10** Check that the LCD backlight is now ON.
- 11** Check the contrast range:
  - a) Press any key - the screen should be black.
  - b) Press any key - the screen should be clear.
  - c) Press any key a third time - the screen should return to normal.

If the maximum and minimum contrast were correct, press **Space**. If they were not correct, press **Esc**.



12 Check all the Workabout keys:

- a) Press any key to begin. A full keyboard map is displayed.
- b) Press each key in turn and note that the selected key image changes from dark grey to light grey.

13 When you are prompted to "Switch on the DC Supply", move the DC Power switch on the Final Test Unit to ON.

14 Check the battery ammeter reading. It should be zero. Check also that the DC Supply indicator (the green LED on the Final Test Unit) is lit.

15 Check that the buzzer sounds. If the buzzers sounds press **Space**. If the buzzer does not sound press **Esc**.

☞ Note: - Check on the Final Test Unit, that the EXP SUPPLY OK indicator is lit.

16 The Expansion Tests Menu will be displayed. To run these optional tests you will need additional hardware which is detailed in Appendix A. To skip these tests select the bottom menu item ("Expansion Test Exit") and press ENTER. Press SPACE when prompted to continue testing if the "All" option was selected.

17 When you are prompted to "Open Drawer", open the Workabout and check the Battery Ground contact by touching the ground connection on the test battery cartridge with the ground detect probe:

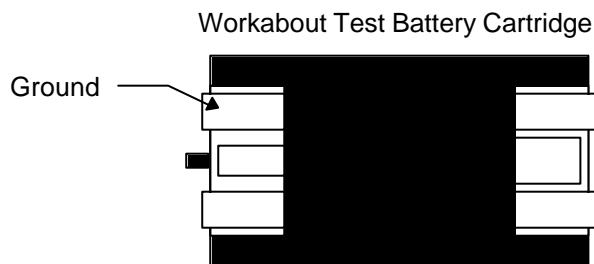

The BATTERY GROUND FAULT indicator should go off when the probe touches the metal.

18 Remove the solid-state disks, battery pack and lithium battery.

19 Close the drawer and press any key.

If all the tests have been passed, press **Space** to continue.

20 Remove the LIF Connector from the Workabout.

The final test for **MX/Rf** is now complete.

☞ Note: - If the test failed, remove the LIF Connector and set up the Workabout again, but when the test menu is displayed, select each test in turn from the test menu until you find the test that fails.

---

## **Scanner Test**

The section describes how to set up and perform Scanner Test on a Workabout MX/RF.

☞ Note: - These instructions do not describe how to perform tests on the Workabout Peripheral product range.

### **Equipment**

You need the following equipment to perform the Test:

Qty	Description	Psion p/no.
1	Any Bar code	
2	AA Batteries	

### **Set - up**

1 Remove any lithium that may be in the UUT. Insert AA batteries observing polarity, close the drawer.

### **Test Sequence**

1 This test instruction details the procedure to perform a post final scanner on a Workabout **MX/RF**

2 Press the **On/Esc** key, which is located on the top left of the unit

3 You will now see the **PSION** main screen

4 Press and hold down the Psion key (Bottom left, a line with a u above it) and then the S key, and then release the keys

15 Now use the **CURSOR** keys to move along to the right of the screen to select the Demman application and press enter

16 Now select the **BARCODING DEMO** using the **CURSOR** keys - **ENTER** to select

17 If Scanner used for the first time use the **ARROW** keys to select scanner type - **Symbol 2** and press **ENTER**, otherwise verify that the scanner type is **Laser 1223** - indicated at the top of the screen

18 At this point, you will most likely get an error, and be told that the program is exiting - this is fine, let it drop you back to the Demman screen, and just re-select the **BARCODING DEMO** - it should now work and say **Laser 1223**

19 Scan a bar code, and if the UUT displays the bar code number correctly, pass the unit, otherwise fail it.

20 Switch off the unit.

20 Remove the batteries from the UUT

Scanner test is now complete

## **Appendix A - Workabout Expansion Option Tests**

The Workabout Final Test Unit incorporates tests for many of the available expansion options. These tests are not fully automated since the test requirements vary depending on machine type, the expansion options fitted and individual configuration options. Finally, these tests require additional hardware (loopback plugs etc) which may not always be available; the selection and operation of these tests is therefore entirely under the control of the user.

These tests provide a quick and simple method of thoroughly testing the expansion options. The various alternative tests, described elsewhere in this manual, may still be used if preferred.

### **Hardware Requirements**

Qty	Description	Psion Part No.
1	Workabout Final Test Unit	1810-0001-01
1	Mains Lead	
1	LIF Cable	
1	Any Suitable Barcode (For Scanner Tests)	N/A
1	Female Loopback Connector (For testing RS232 ports)	1810-0002-01
1	Male Loopback Connector (For testing TTL ports)	1810-0003-01
1	IrDA Mirror Unit (For testing units with IrDA ports)	1810-0004-01
1	Extended Systems "XTNDAccess IrDA PC Adapter" - (ESI-09680)  For use in conjunction with the "IrDA Mirror Unit" and therefore only required for testing units with IrDA ports.	A7821-0002-01

 Note: - Connection details for making loopback plugs may be found at the end of this Appendix.

### The Expansion Menu

The various Expansion Tests are available through the Main Menu either by selecting "Expansion" or as part of the "All" option. When selected, the following Menu to be displayed:-

**EXPANSION - FINAL-MX 2.04A**

**RS232 Loopback Test**

**IrDA Loopback Test**

**TTL Loopback Tests**

**Scanner Tests**

**Expansion Test Exit**

**Arrow keys move, ENTER selects**

When testing is complete, select the bottom menu item (“Expansion Test Exit”) and press ENTER.

### **RS232 Loopback Test**

1. Select the RS232 test from the UUT menu and press ENTER.
2. Attach the RS232 loopback plug to the RS232 port of the UUT.
3. The RS232 port is normally defined as TTY:A. Use the arrow keys to alter this setting if necessary. The SPACE key will list all available ports.
4. Press ENTER to test. A Pass or Fail message will be displayed.

### **TTL Loopback Test**

1. Select the TTL test from the UUT menu and press ENTER.
2. Attach TTL loopback plug to the TTL port of the UUT.
3. The TTL port has two modes of operation – “Normal” and “Inverted”. These are normally mapped to TTY:D and TTY:G respectively. Use the arrow keys when prompted to alter the port letters if necessary. The SPACE key will list all available ports.
4. Press ENTER to test the “Normal” mode.
5. Repeat Steps 3 and 4 when prompted to test the “Inverted” mode.

### **IrDA Loopback Test**

*This test requires the IrDA Mirror test equipment. Essentially, this is a small box, powered by an external power unit and connected to an Extended Systems “Jet-Eye”*

1. Set up the “IrDA Mirror” The red “Power” LED should be ON. The green and amber LED’s will flash briefly when power is first applied after which they should be OFF to indicate that the IrDA Mirror is ready.
2. Select the IrDA test from the UUT menu and press ENTER.
3. Select the “Top” or “Bottom” IrDA port, as appropriate for the UUT. Note: If the UUT has two IrDA ports then you will need to repeat the procedure to test both the “Top” and “Bottom” options in turn.
4. The IrDA port is normally defined as TTY:R. Use the arrow keys to alter this setting if necessary. The SPACE key will list all available ports.

5. Point the IrDA window on the UUT at the Jet-Eye connected to the IrDA Mirror.
6. Press ENTER to test. A Pass or Fail message will be displayed.

### **Scanner Tests**

*Note: Before running this test ensure that the “DC Power Switch” on the Workabout Final Test Unit is set to ON.*

*Note: This test does not currently support the Long Range Scanner option.*

1. Select “Scanner Tests” from the expansion menu.
2. Point the Scanner at any suitable barcode.
3. Press ENTER to start the scanner.
4. A successfully read barcode will be displayed . A fail message will be displayed if a valid barcode is not read within a short period.
5. Press ENTER (twice) to repeat the test.

### **Loopback Connector Details**

The loopback plugs consist of a 9 Way “D” type connector with various pins connected together by means of short wire links. The pins which need to be linked together are shown in the table below:-

RS232 Loopback – 9 Way Female “D”		TTL Loopback – 9 Way Male “D” Type	
1	Link to pins 4 & 6	1	Link to pins 4 & 6
2	Link to pin 3	2	Link to pin 3
3	Link to pin 2	3	Link to pin 2
4	Link to pins 1 & 6	4	Link to pins 1 & 6
5	No Connection	5	No Connection
6	Link to pins 1 & 4	6	Link to pins 1 & 4
7	Link to pin 8	7	Link to pin 8
8	Link to pin 7	8	Link to pin 7
9	No Connection	9	No Connection

**-END-**