

Tru-Metric™

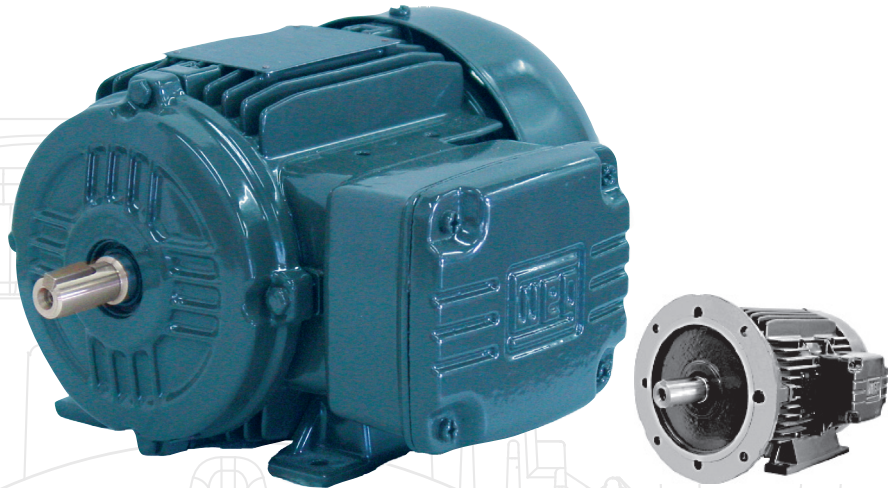

IEC
TRU-METRIC™

SHAFT

Made of ASTM 1045 carbon steel, it is thermally treated to minimize internal stress, to resist bending and fatigue caused by torsion and flexing.

FRAME

Made of aluminum or FC-200 cast iron, with external fins for maximum cooling effect. Removable feet on aluminum frame.

NAMEPLATE

Dual Frequency (60/50Hz) stainless steel nameplate contains a complete and permanent record of all motor data.

FAN COVER

Steel covers on 63 up to 132M frames and cast iron on frames 160M and up.

TERMINAL BOX

Oversized, cast iron construction. Gasketed lid and between box and frame. NPT threads holes to connect conduit or cable glands.

FAN

Made of rigid plastic from frames 63 up to 315S/M and aluminum for frame 355M/L. Non sparking, non-toxic, resistant to environmental conditions, and ensures low noise operation.

ENDSHIELDS

Made of cast iron, with external fins for heat dissipation. They also have polished bearing housings for longer bearing life.

EYEBOLT

For easy handling, motors in 112 frames and larger are provided with an eyebolt. Footless motors are provided with two eyebolts.

DRAIN PLUGS

Provided with automatic drain plug that quickly drains condensation

DOUBLE OIL LIP SEALS

In both endshields to protect bearings and motor from the aggressive components present in the environment. Frames 280 and above provided with V-ring.

ROTOR

Aluminum die cast into a magnetic steel lamination for low electric losses. Dynamically balanced for smooth operation, reduced vibration and noise.

WINDING

All copper winding wire enameled with class 'H' polyester varnish.

BEARINGS

The bearings are dimensioned to ensure long life to the motor, even under heavy working conditions. The positive pressure lubrication system includes a drain that allows the outflow of excess grease on 160M frames up to 355M/L.

INCLUDES TERMINAL BLOCKS

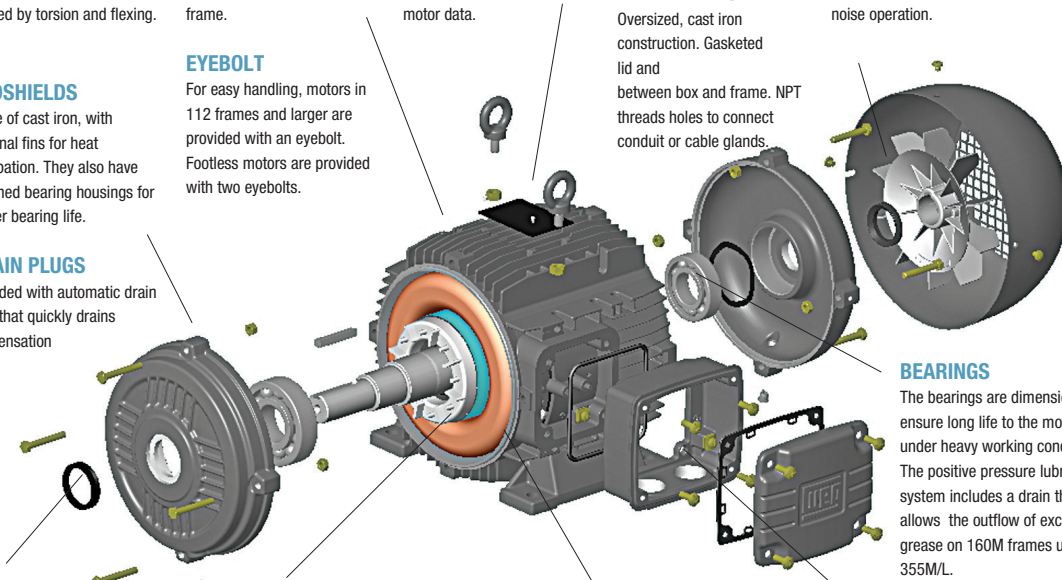



THREE-PHASE – REMOVABLE FEET AND RIGID BASE

This line is designed and built according to European IEC 34 and IEC 79 Standards. The enclosure TEFC (IP55) is ideal for indoor and outdoor applications. These motors are tested according to IEEE 112 std., method 'B' and their efficiency values are certified according to EPACT regulations (CC029A).

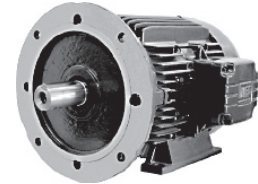
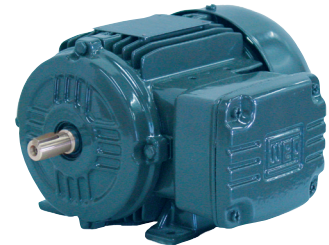

HIGHLIGHTS

- Meets or exceeds EPACT requirement
- Aluminum frames with removable feet
- IEC 34 and IEC 79 standards

APPLICATIONS

- Blowers
- Compressors
- Pumps
- Conveyor
- Textiles
- Marine duty

OPTIONAL FEATURES

- Flanges
- Class 'H' insulation
- Taconite labyrinth seal
- Cable glands
- Space heaters
- Double shaft end
- Thermistor, Thermostats or RTD's (PT100)
- Drip cover (canopy) for shaft down applications
- Special painting plan for hostile environments
- Roller bearings on drive end

STANDARD FEATURES

- Efficiency Certification number CC029A according to US Department of Energy Regulations
- Three-phase, 60/50Hz
- Voltage: 230/460V (60Hz); 380-415V (50Hz)
- Aluminum frames with removable feet (63 up to 132M)
- Cast iron frames (63 up to 355M/L) with rigid base
- Squirrel cage rotor / Aluminum die cast
- Totally Enclosed Fan Cooled TEFC (IP55)
- Oil Seal on both endshields up to 250, V-ring for 280 and up.
- Class 'F' insulation
- Service Factor: 1.15 in 60Hz & 1.0 50Hz
- Constant Torque 4:1 and 10:1 Variable Torque
- Temperature rise: Class 'B' (80°C)
- Continuous Duty (S1)
- 104°F (40°C) ambient temperature
- Altitude: 3300 ft (1000 m)
- Stainless steel nameplate on both aluminum and cast iron frames
- Finish painting: Synthetic enamel alkyd resin base
- Color: Dark Grey (RAL 7022)
- Grease relief system in frame 160M and above
- Drilled and tapped shaft
- Automatic drain plug
- Standard mounting: F2 (B3R) Also available in F1 (B3L) and F0 (B3T)
- Terminal block
- Class 1, Div 2, Groups A, B, C & D, T3

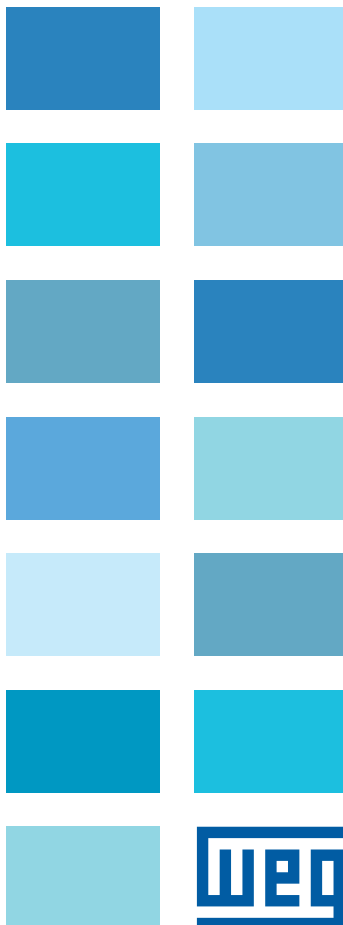

Note: Motors are tested according to IEEE 112 std. - method 'B' or C390 CSA. Energy efficiency motors verified by UL in addition to the DOE.

* Ball bearings. Exception to 355M/L 4, 6 and 8 pole, with roller bearing in the drive end.

TRU-METRIC™ FRAME

TEFC

EPACT CC# CC029A



Tru-Metric™

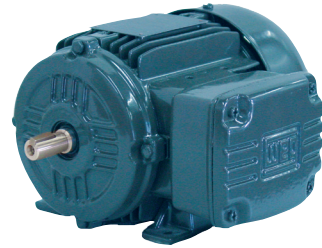

FOOT MOUNT

kW	HP	RPM 60Hz/50Hz	IEC Frame	Catalog Number	List Price	Mult. Sym.	Approx. Shipp. Weight Lbs	FL Amps 460V	FL Eff. %	Voltage 60 Hz/ 50 Hz	Notes
0.18	0.25	3600 / 3000	63	.1836EP3EAL63	280	T1	11	0.48	68.0	230/460V // 380-415V	AL
		3600 / 3000	63	.1836EP3E63	280	T1	18	0.48	68.0	230/460V // 380-415V	◆
		1800 / 1500	63	.1818EP3EAL63	267	T1	13	0.51	69.0	230/460V // 380-415V	AL
		1800 / 1500	63	.1818EP3E63	267	T1	21	0.51	69.0	230/460V // 380-415V	◆
		1200 / 1000	71	.1812EP3EAL71	338	T1	16	0.77	61.0	230/460V // 380-415V	AL
		1200 / 1000	71	.1812EP3E71	338	T1	27	0.77	61.0	230/460V // 380-415V	◆
		900 / 750	80	.1809EP3EAL80	540	T1	22	0.80	50.5	230/460V // 380-415V	AL
		900 / 750	80	.1809EP3E80	540	T1	34	0.80	50.5	230/460V // 380-415V	◆
0.25	0.33	3600 / 3000	63	.2536EP3EAL63	286	T1	13	0.62	70.0	230/460V // 380-415V	AL
		3600 / 3000	63	.2536EP3E63	286	T1	18	0.62	70.0	230/460V // 380-415V	◆
		1800 / 1500	71	.2518EP3EAL71	282	T1	16	0.68	73.0	230/460V // 380-415V	AL
		1800 / 1500	71	.2518EP3E71	282	T1	27	0.68	73.0	230/460V // 380-415V	◆
		1200 / 1000	71	.2512EP3EAL71	363	T1	18	1.00	64.0	230/460V // 380-415V	AL
		1200 / 1000	71	.2512EP3E71	363	T1	29	1.00	64.0	230/460V // 380-415V	◆
		900 / 750	80	.2509EP3EAL80	583	T1	24	0.87	57.5	230/460V // 380-415V	AL
		900 / 750	80	.2509EP3E80	583	T1	36	0.87	57.5	230/460V // 380-415V	◆
0.37	0.5	3600 / 3000	71	.3736EP3EAL71	309	T1	15	0.83	73.0	230/460V // 380-415V	AL
		3600 / 3000	71	.3736EP3E71	309	T1	25	0.83	73.0	230/460V // 380-415V	◆
		1800 / 1500	71	.3718EP3EAL71	290	T1	16	1.06	73.0	230/460V // 380-415V	AL
		1800 / 1500	71	.3718EP3E71	290	T1	27	1.06	73.0	230/460V // 380-415V	◆
		1200 / 1000	80	.3712EP3EAL80	378	T1	21	1.07	64.0	230/460V // 380-415V	AL
		1200 / 1000	80	.3712EP3E80	378	T1	34	1.07	64.0	230/460V // 380-415V	◆
		900 / 750	90S	.3709EP3EAL90S	662	T1	36	1.35	61.5	230/460V // 380-415V	AL
		900 / 750	90S	.3709EP3E90S	662	T1	43	1.35	61.5	230/460V // 380-415V	◆
0.55	0.75	3600 / 3000	71	.5536EP3EAL71	316	T1	18	1.14	76.0	230/460V // 380-415V	AL
		3600 / 3000	71	.5536EP3E71	316	T1	27	1.14	76.0	230/460V // 380-415V	◆
		1800 / 1500	80	.5518EP3EAL80	333	T1	23	1.25	77.0	230/460V // 380-415V	AL
		1800 / 1500	80	.5518EP3E80	333	T1	34	1.25	77.0	230/460V // 380-415V	◆
		1200 / 1000	80	.5512EP3EAL80	405	T1	26	1.63	66.0	230/460V // 380-415V	AL
		1200 / 1000	80	.5512EP3E80	405	T1	38	1.63	66.0	230/460V // 380-415V	◆
		900 / 750	90L	.5509EP3EAL90L	696	T1	40	2.12	62.5	230/460V // 380-415V	AL
		900 / 750	90L	.5509EP3E90L	696	T1	49	2.12	62.5	230/460V // 380-415V	◆
0.75	1	3600 / 3000	80	.7536EP3EAL80	345	T1	23	1.42	79.0	230/460V // 380-415V	AL
		3600 / 3000	80	.7536EP3E80	345	T1	34	1.42	79.0	230/460V // 380-415V	◆
		1800 / 1500	80	.7518EP3EAL80	339	T1	26	1.51	80.0	230/460V // 380-415V	AL
		1800 / 1500	80	.7518EP3E80	339	T1	38	1.51	80.0	230/460V // 380-415V	◆
		1200 / 1000	90S	.7512EP3EAL90S	452	T1	34	1.71	80.0	230/460V // 380-415V	AL
		1200 / 1000	90S	.7512EP3E90S	452	T1	54	1.71	80.0	230/460V // 380-415V	◆
		900 / 750	100L	.7509EP3EAL100L	756	T1	52	2.31	74.0	230/460V // 380-415V	AL
		900 / 750	100L	.7509EP3E100L	756	T1	65	2.31	74.0	230/460V // 380-415V	◆

- ELECTRICAL FEATURES ON PAGE B-18-B-23.
- MECHANICAL FEATURES ON PAGE B-74-B-80.

AL= Aluminum Frame with removable feet

◆= Product may not be available from stock

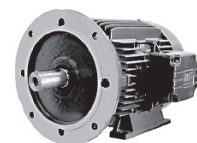

IEC TRU-METRIC™

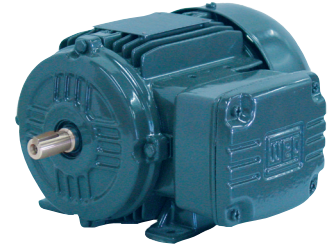

FOOT MOUNT

kW	HP	RPM 60Hz/50Hz	IEC Frame	Catalog Number	List Price	Mult. Sym.	Approx. Shipp. Weight Lbs	FL Amps 460V	FL Eff. %	Voltage 60 Hz/ 50 Hz	Notes
1.1	1.5	3600 / 3000	80	00136EP3EAL80	370	T1	25	2.07	82.5	230/460V // 380-415V	AL
		3600 / 3000	80	00136EP3E80	370	T1	38	2.07	82.5	230/460V // 380-415V	◆
		1800 / 1500	90S	00118EP3EAL90S	409	T1	34	2.16	84.0	230/460V // 380-415V	AL
		1800 / 1500	90S	00118EP3E90S	409	T1	58	2.16	84.0	230/460V // 380-415V	◆
		1200 / 1000	90L	00112EP3EAL90L	649	T1	43	2.75	78.5	230/460V // 380-415V	AL
		1200 / 1000	90L	00112EP3E90L	649	T1	54	2.75	78.5	230/460V // 380-415V	◆
		900 / 750	100L	00109EP3EAL100L	767	T1	58	3.26	77.0	230/460V // 380-415V	AL
900 / 750	100L	00109EP3E100L	767	T1	69	3.26	77.0	230/460V // 380-415V	◆		
1.5	2	3600 / 3000	90S	00156EP3EAL90S	438	T1	35	2.70	84.0	230/460V // 380-415V	AL
		3600 / 3000	90S	00156EP3E90S	438	T1	47	2.70	84.0	230/460V // 380-415V	◆
		1800 / 1500	90L	00158EP3EAL90L	456	T1	43	2.99	84.0	230/460V // 380-415V	AL
		1800 / 1500	90L	00158EP3E90L	456	T1	56	2.99	84.0	230/460V // 380-415V	◆
		1200 / 1000	100L	00152EP3EAL100L	706	T1	69	3.73	81.5	230/460V // 380-415V	AL
		1200 / 1000	100L	00152EP3E100L	706	T1	76	3.73	81.5	230/460V // 380-415V	◆
		900 / 750	112M	00159EP3EAL112M	870	T1	86	4.08	82.5	230/460V // 380-415V	AL
900 / 750	112M	00159EP3E112M	870	T1	108	4.08	82.5	230/460V // 380-415V	◆		
2.2	3	3600 / 3000	90L	00236EP3EAL90L	657	T1	36	4.14	85.5	230/460V // 380-415V	AL
		3600 / 3000	90L	00236EP3E90L	657	T1	54	4.14	85.5	230/460V // 380-415V	◆
		1800 / 1500	100L	00218EP3EAL100L	548	T1	74	4.44	87.5	230/460V // 380-415V	AL
		1800 / 1500	100L	00218EP3E100L	548	T1	102	4.44	87.5	230/460V // 380-415V	◆
		1200 / 1000	112M	00212EP3EAL112M	972	T1	108	4.69	86.5	230/460V // 380-415V	AL
		1200 / 1000	112M	00212EP3E112M	972	T1	124	4.69	86.5	230/460V // 380-415V	◆
		900 / 750	132S	00209EP3EAL132S	1,228	T1	145	4.70	84.0	230/460V // 380-415V	AL
900 / 750	132S	00209EP3E132S	1,228	T1	167	4.70	84.0	230/460V // 380-415V	◆		
3	4	3600 / 3000	100L	00336EP3EAL100L	700	T1	58	5.21	84.0	230/460V // 380-415V	AL
		3600 / 3000	100L	00336EP3E100L	700	T1	76	5.21	84.0	230/460V // 380-415V	◆
		1800 / 1500	100L	00318EP3EAL100L	584	T1	74	5.89	87.5	230/460V // 380-415V	AL
		1800 / 1500	100L	00318EP3E100L	584	T1	102	5.89	87.5	230/460V // 380-415V	◆
		1200 / 1000	132S	00312EP3AL132S	1,039	T1	155	6.83	87.5	230/460V // 380-415V	AL
		1200 / 1000	132S	00312EP3132S	1,039	T1	161	6.83	87.5	230/460V // 380-415V	◆
		900 / 750	132M	00309EP3EAL132M	1,400	T1	167	6.40	84.0	230/460V // 380-415V	AL
900 / 750	132M	00309EP3E132M	1,400	T1	185	6.40	84.0	230/460V // 380-415V	◆		
4	5.5	3600 / 3000	112M	00436EP3EAL112M	760	T1	80	6.83	87.5	230/460V // 380-415V	AL
		3600 / 3000	112M	00436EP3E112M	760	T1	110	6.83	87.5	230/460V // 380-415V	◆
		1800 / 1500	112M	00418EP3EAL112M	590	T1	99	7.19	89.5	230/460V // 380-415V	AL
		1800 / 1500	112M	00418EP3E112M	590	T1	117	7.19	89.5	230/460V // 380-415V	◆
		1200 / 1000	132M	00412EP3EAL132M	1,090	T1	143	8.44	87.5	230/460V // 380-415V	AL
		1200 / 1000	132M	00412EP3E132M	1,090	T1	163	8.44	87.5	230/460V // 380-415V	◆
		900 / 750	160M	00409EP3E160M	1,693	T1	269	9.63	85.5	230/460V // 380-415V	

- ELECTRICAL FEATURES ON PAGE B-18–B-23.
- MECHANICAL FEATURES ON PAGE B-74–B-80.

AL= Aluminum Frame with removable feet

◆ = Product may not be available from stock

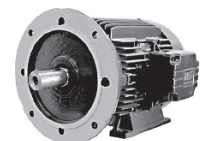



Tru-Metric™

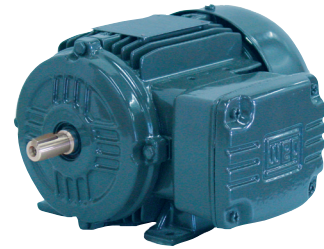

FOOT MOUNT

KW	HP	RPM 60Hz/50Hz	IEC Frame	Catalog Number	List Price	Mult. Sym.	Approx. Shipp. Weight Lbs	FL Amps 460V	FL Eff. %	Voltage 60 Hz/ 50 Hz	Notes
5.5	7.5	3600 / 3000	132S	00536EP3EAL132S	995	T1	123	8.97	88.5	230/460V // 380-415V	AL
		3600 / 3000	132S	00536EP3E132S	995	T1	150	8.97	88.5	230/460V // 380-415V	◆
		1800 / 1500	132S	00518EP3EAL132S	810	T1	101	9.29	89.5	230/460V // 380-415V	AL
		1800 / 1500	132S	00518EP3E132S	810	T1	156	9.29	89.5	230/460V // 380-415V	◆
		1200 / 1000	132M	00512EP3EAL132M	1,504	T1	167	11.3	87.5	230/460V // 380-415V	AL
		1200 / 1000	132M	00512EP3E132M	1,504	T1	187	11.3	87.5	230/460V // 380-415V	◆
7.5	10	3600 / 3000	132S	00736EP3EAL132S	1,123	T1	123	12.4	89.5	230/460V // 380-415V	AL
		3600 / 3000	132S	00736EP3E132S	1,123	T1	163	12.4	89.5	230/460V // 380-415V	◆
		1800 / 1500	132M	00718EP3EAL132M	965	T1	161	12.7	89.5	230/460V // 380-415V	AL
		1800 / 1500	132M	00718EP3E132M	965	T1	189	12.7	89.5	230/460V // 380-415V	◆
		1200 / 1000	160M	00712EP3E160M	1,960	T1	302	14.2	89.5	230/460V // 380-415V	
		900 / 750	160L	00709EP3E160L	2,412	T1	346	15.2	88.5	230/460V // 380-415V	
11	15	3600 / 3000	160M	01136EP3E160M	1,787	T1	269	18.9	90.2	230/460V // 380-415V	
		1800 / 1500	160M	01118EP3E160M	1,467	T1	302	20.0	91.0	230/460V // 380-415V	
		1200 / 1000	160L	01112EP3E160L	2,686	T1	326	21.6	90.2	230/460V // 380-415V	
		900 / 750	180L	01109EP3E180L	3,505	T1	444	20.3	89.5	230/460V // 380-415V	
15	20	3600 / 3000	160 M	01536EP3E160M	2,051	T1	271	25.1	90.2	230/460V // 380-415V	
		1800 / 1500	160 L	01518EP3E160L	1,800	T1	313	26.9	91.0	230/460V // 380-415V	
		1200 / 1000	180 L	01512EP3E180L	3,301	T1	499	23.5	92.0	230/460V // 380-415V	
		900 / 750	200 L	01509EP3E200L	4,485	T1	541	30.9	89.5	230/460V // 380-415V	
18.5	25	3600 / 3000	160 L	01836EP3E160L	2,486	T1	313	30.0	91.0	230/460V // 380-415V	
		1800 / 1500	180 M	01818EP3E180M	2,286	T1	426	31.8	92.4	230/460V // 380-415V	
		1200 / 1000	200 L	01812EP3E200L	4,153	T1	539	31.7	91.7	230/460V // 380-415V	
		900 / 750	225 S/M	01809EP3E225S/M	5,270	T1	860	30.9	91.7	230/460V // 380-415V	
22	30	3600 / 3000	180 M	02236EP3E180M	2,968	T1	437	35.7	91.0	230/460V // 380-415V	
		1800 / 1500	180 L	02218EP3E180L	2,741	T1	470	36.9	92.4	230/460V // 380-415V	
		1200 / 1000	200 L	02212EP3E200L	4,185	T1	607	37.4	92.4	230/460V // 380-415V	
		900 / 750	225 S/M	02209EP3E225S/M	6,702	T1	915	37.4	92.4	230/460V // 380-415V	
30	40	3600 / 3000	200 L	03036EP3E200L	4,145	T1	585	48.5	92.4	230/460V // 380-415V	
		1800 / 1500	200 L	03018EP3E200L	3,665	T1	574	51.2	93.0	230/460V // 380-415V	
		1200 / 1000	225 S/M	03012EP3E225S/M	6,744	T1	917	50.6	93.0	230/460V // 380-415V	
		900 / 750	250 S/M	03009EP3E250S/M	7,909	T1	1125	50.6	93.0	230/460V // 380-415V	
37	50	3600 / 3000	200 L	03736EP3E200L	4,664	T1	618	59.1	92.4	230/460V // 380-415V	
		1800 / 1500	225 S/M	03718EP3E225S/M	5,936	T1	1003	58.1	93.0	230/460V // 380-415V	
		1200 / 1000	250 S/M	03712EP3E250S/M	8,725	T1	1147	60.9	93.0	230/460V // 380-415V	
		900 / 750	280 S/M	03709EP3E280S/M	10,492	T1	1565	64.4	92.4	230/460V // 380-415V	
45	60	3600 / 3000	225 S/M	04536EP3E225S/M	6,767	T1	959	67.5	93.0	230/460V // 380-415V	
		1800 / 1500	225 S/M	04518EP3E225S/M	6,282	T1	992	67.8	93.6	230/460V // 380-415V	
		1200 / 1000	280 S/M	04512EP3E280S/M	9,669	T1	1521	73.2	94.1	460V // 380-415V	
		900 / 750	280 S/M	04509EP3E280S/M	11,442	T1	1565	80.0	94.1	460V // 380-415V	

IEC
TRU-METRIC™

- ELECTRICAL FEATURES ON PAGE B-18-B-23.
- MECHANICAL FEATURES ON PAGE B-74-B-80.

AL= Aluminum Frame with removable feet

◆ = Product may not be available from stock

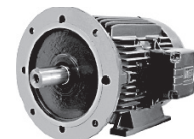



TRU-METRIC™ FRAME

TEFC
EPACT CC# CC029A

Tru-Metric™

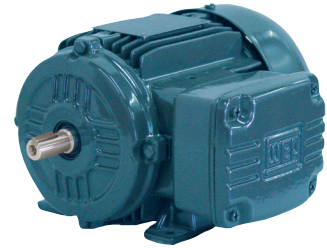

FOOT MOUNT

kW	HP	RPM 60Hz/50Hz	IEC Frame	Catalog Number	List Price	Mult. Sym.	Approx. Shipp. Weight Lbs	FL Amps 460V	FL Eff. %	Voltage 60 Hz/ 50 Hz	Notes
55	75	3600 / 3000	250 S/M	05536EP3E250S/M	8,373	T1	1235	81.6	93.0	230/460V // 380-415V	
		1800 / 1500	250 S/M	05518EP3E250S/M	7,617	T1	1147	83.4	94.1	230/460V // 380-415V	
		1200 / 1000	280 S/M	05512EP3E280S/M	11,053	T1	1620	89.1	94.5	460V // 380-415V	
		900 / 750	315 S/M	05509EP3E315S/M	13,731	T1	1808	93.7	94.5	460V // 380-415V	
75	100	3600 / 3000	280 S/M	07536EP3E280S/M	10,601	T1	1863	116	93.6	460V // 380-415V	
		3600 / 3000	280 S/M	07536EP3G280S/M	10,601	T1	1863	116	93.6	460V // 380-415V	
		1800 / 1500	280 S/M	07518EP3E280S/M	10,500	T1	1631	114	94.5	460V // 380-415V	
		1800 / 1500	280 S/M	07518EP3G280S/M	10,500	T1	1631	114	94.5	460V // 380-415V	
		1200 / 1000	315 S/M	07512EP3E315S/M	14,007	T1	1797	117	95.0	460V // 380-415V	
		1200 / 1000	315 S/M	07512EP3G315S/M	14,007	T1	1797	117	95.0	460V // 380-415V	
		900 / 750	315 S/M	07509EP3E315S/M	16,649	T1	2205	133	93.0	460V // 380-415V	
		900 / 750	315 S/M	07509EP3G315S/M	16,649	T1	2205	133	93.0	460V // 380-415V	
90	125	3600 / 3000	280 S/M	09036EP3G280S/M	14,212	T1	1808	136	94.5	460V // 380-415V	
		1800 / 1500	280 S/M	09018EP3G280S/M	12,937	T1	1929	137	94.5	460V // 380-415V	
		1200 / 1000	315 S/M	09012EP3G315S/M	16,531	T1	1984	140	95.0	460V // 380-415V	
		900 / 750	315 S/M	09009EP3G315S/M	19,007	T1	2315	148	95.4	460V // 380-415V	
110	150	3600 / 3000	315 S/M	11036EP3G315S/M	17,865	T1	2028	166	94.5	460V // 380-415V	
		1800 / 1500	280 S/M	11018EP3G280S/M	14,516	T1	2028	167	95.0	460V // 380-415V	
		1200 / 1000	315 S/M	11012EP3G315S/M	18,105	T1	2359	182	95.0	460V // 380-415V	
		900 / 750	355 M/L	11009EP3G355M/L	24,920	T1	3462	191	94.1	460V // 380-415V	
132	175	3600 / 3000	315 S/M	13236EP3G315S/M	19,703	T1	2183	197	94.5	460V // 380-415V	
		1800 / 1500	315 S/M	13218EP3G315S/M	16,772	T1	2392	205	95.0	460V // 380-415V	
		1200 / 1000	355 M/L	13212EP3G355M/L	24,315	T1	3411	221	95.0	460V // 380-415V	
		900 / 750	355 M/L	13209EP3G355M/L	30,078	T1	3583	229	94.1	460V // 380-415V	
150	200	3600 / 3000	315 S/M	15036EP3G315S/M	22,312	T1	2381	220	95.0	460V // 380-415V	
		1800 / 1500	315 S/M	15018EP3G315S/M	18,506	T1	2403	233	95.0	460V // 380-415V	
		1200 / 1000	355 M/L	15012EP3G355M/L	28,480	T1	3705	248	95.0	460V // 380-415V	
		900 / 750	355 M/L	15009EP3G355M/L	38,314	T1	3903	257	94.1	460V // 380-415V	
185	250	3600 / 3000	315 S/M	18536EP3G315S/M	23,687	T1	2381	277	95.4	460V // 380-415V	
		1800 / 1500	315 S/M	18518EP3G315S/M	23,435	T1	2414	294	95.0	460V // 380-415V	
		1200 / 1000	355 M/L	18512EP3G355M/L	38,854	T1	3925	306	95.0	460V // 380-415V	
		900 / 750	355 M/L	18509EP3G355M/L	41,203	T1	4542	315	94.5	460V // 380-415V	
220	300	3600 / 3000	355 M/L	22036EP3G355M/L	39,475	T1	4035	318	95.4	460V // 380-415V	
		1800 / 1500	355 M/L	22018EP3G355M/L	32,352	T1	3969	333	95.4	460V // 380-415V	
		1200 / 1000	355 M/L	22012EP3G355M/L	41,020	T1	4355	368	95.0	460V // 380-415V	
		900 / 750	355 M/L	22009EP3G355M/L	51,705	T1	4653	370	94.5	460V // 380-415V	
260	350	3600 / 3000	355 M/L	26036EP3G355M/L	45,212	T1	4146	372	95.4	460V // 380-415V	
		1800 / 1500	355 M/L	26018EP3G355M/L	39,072	T1	3440	393	95.4	460V // 380-415V	
		1200 / 1000	355 M/L	26012EP3G355M/L	47,322	T1	4410	429	95.0	460V // 380-415V	
300	400	1800 / 1500	355 M/L	30018EP3G355M/L	42,828	T1	4300	449	95.4	460V // 380-415V	●
		1200 / 1000	355 M/L	30012EP3G355M/L	53,832	T1	4476	483	95.0	460V // 380-415V	●
330	450	1200 / 1000	355 M/L	33012EP3G355M/L	57,640	T1	4587	545	95.0	460V // 380-415V	●

AL = Aluminium frame - with removable feet

CI = Cast Iron frame - fixed or standard base

- ELECTRICAL FEATURES ON PAGE B-18-B-23.
- MECHANICAL FEATURES ON PAGE B-74-B-80.

● = Roller Bearing

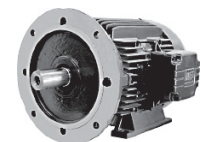

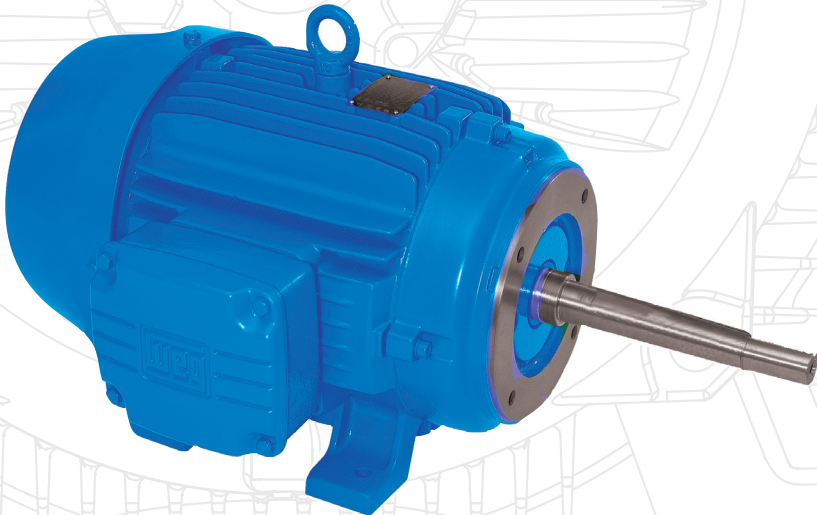
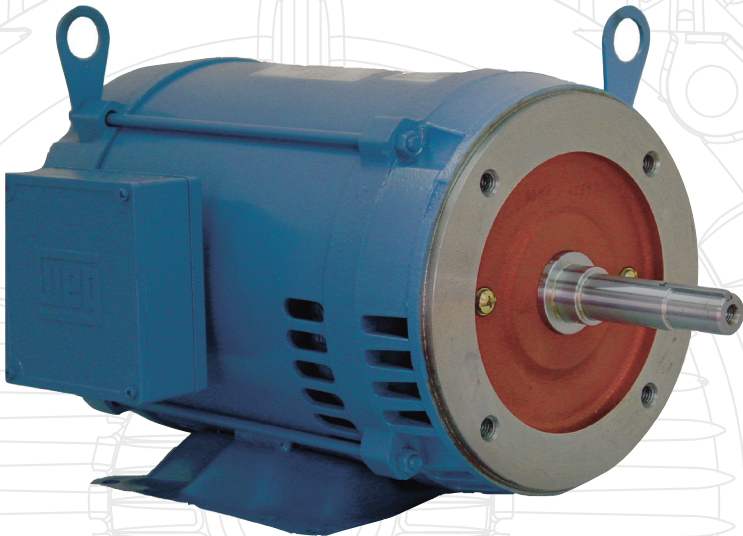

PUMP
MOTORS





Pump Motors Jet Pump



ODP

SINGLE PHASE

These versatile motors have the torque and durability for the toughest commercial applications, yet are also economical choices for residential applications. The motors are available with or without base and in Form J or C configurations.

APPLICATIONS

- Commercial and Industrial pumps
- Residential pumps
(Jacuzzis, pools, hot tubs)
- Jet Pump motor system
- Hydraulic pumps

OPTIONAL FEATURES

- 4 pole
- Class “F” insulation
- Special voltages
- Drip cover
- Rotation: CW (viewed from shaft end)
- Other mounting configurations

STANDARD FEATURES

- Single-phase, 2 pole, 60Hz
- Voltage: 115/208-230V
- Squirrel cage rotor
- Start capacitor
- Sealed ball bearings (drive end)
- Fan cooled (internally)
- Service factor according to NEMA standard MG 1-18.329
- Insulation class ‘B’ (130°C)
- Automatic Thermal Overload (ATO)
- Continuous duty (S1), 40°C ambient
- Standard: NEMA-MG 1-18.326
- Stainless steel shaft end
- Color: Munsell N1 (Black)
- Counter Clock-wise, viewed from shaft end

HIGHLIGHTS

- Single and two-speed available
- Space Heaters
- Multiple endbell drains
- External and Internal Epoxy Paint
- External Slinger (Umbrella Seal)

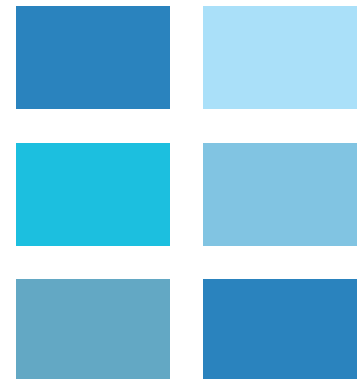

All motors are tested according to IEEE 12 Std. – Method ‘B’ or C390 CSA.



THREADED – WITH BASE – ODP SINGLE-PHASE

HP	RPM	NEMA Frame	Catalog Number	List Price	Multi. Sym.	Approx. Shipp. Weight Lbs.	FL Amps 460	FL Eff %	“C” Dimension (in.)	Voltage	NOTES
1/3	3600	56J	.33360S1BJP56J	254	P1B	21	1.75	3.50	10.732	115/208-230V	§
1/2	3600	56J	.50360S1BJP56J	258	P1B	24	1.60	4.70	11.126	115/208-230V	§
3/4	3600	56J	.75360S1BJP56J	296	P1B	32	1.50	5.70	11.913	115/208-230V	§
1	3600	56J	001360S1BJP56J	334	P1B	36	1.40	6.10	12.031	115/208-230V	§
1 1/2	3600	56J	001560S1BJP56J	382	P1B	40	1.30	8.50	13.212	115/208-230V	§
2	3600	56HJ	002360S1BJP56J	438	P1B	48	1.20	10.8	14.000	115/208-230V	§
3	3600	56HJ	003360S1DJP56J	499	P1B	53	1.15	13.8	14.787	230V	§

- ELECTRICAL FEATURES ON PAGE B-31.
- MECHANICAL FEATURES ON PAGE B-78.

§ = Automatic Thermal Overload



THREADED – LESS BASE – ODP SINGLE-PHASE

HP	RPM	NEMA Frame	Catalog Number	List Price	Multi. Sym.	Approx. Shipp. Weight Lbs	Service Factor	FL Amps 230V	"C" Dimension (in.)	Voltage	Notes
1/2	3600	56J	.5036OS1BJPR56J	258	P1B	24	1.60	4.70	11.126	115/208-230V	§
3/4	3600	56J	.7536OS1BJPR56J	296	P1B	32	1.50	5.70	11.913	115/208-230V	§
1	3600	56J	00136OS1BJPR56J	334	P1B	36	1.40	6.10	12.031	115/208-230V	§
1 1/2	3600	56J	00156OS1BJPR56J	382	P1B	40	1.30	8.50	13.212	115/208-230V	§
2	3600	56HJ	00236OS1BJPR56J	438	P1B	48	1.20	10.8	14.000	115/208-230V	§
3	3600	56HJ	00336OS1DJPR56J	499	P1B	53	1.15	13.8	14.787	230V	§

• ELECTRICAL FEATURES ON PAGE B-31. • MECHANICAL FEATURES ON PAGE B-78.



KEYED – 'C' FACE LESS BASE – ODP SINGLE-PHASE

HP	RPM	NEMA Frame	Catalog Number	List Price	Multi. Sym.	Approx. Shipp. Weight Lbs.	Service Factor	FL Amps 230V	"C" Dimension (in.)	Voltage	NOTES
1/3	3600	56C	.3336OS1BJPR56C	237	P1A	21	1.75	3.50	10.232	115/208-230V	§
1/2	3600	56C	.5036OS1BJPR56C	255	P1A	24	1.60	4.70	10.826	115/208-230V	§
3/4	3600	56C	.7536OS1BJPR56C	297	P1A	32	1.50	5.70	11.413	115/208-230V	§
1	3600	56C	00136OS1BJPR56C	317	P1A	36	1.40	6.10	11.531	115/208-230V	§
1 1/2	3600	56C	00156OS1BJPR56C	338	P1A	40	1.30	8.50	12.712	115/208-230V	§
2	3600	56HC	00236OS1BJPR56C	424	P1A	48	1.20	10.8	13.500	115/208-230V	§
3	3600	56HC	00336OS1DJPR56C	482	P1A	53	1.15	13.8	14.287	230V	§

• ELECTRICAL FEATURES ON PAGE B-31. • MECHANICAL FEATURES ON PAGE B-78.

THREADED – WITH BASE – TEFC SINGLE-PHASE

HP	RPM	NEMA Frame	Catalog Number	List Price	Multi. Sym.	Approx. Shipp. Weight Lbs.	Service Factor	FL Amps 230V	"C" Dimension (in.)	Voltage	NOTES
1/3	3600	56J	.3336ES1BJP56J	282	P1B	36	1.15	2.80	11.996	115/208-230V	§
1/2	3600	56J	.5036ES1BJP56J	300	P1B	40	1.15	3.80	11.996	115/208-230V	§
3/4	3600	56J	.7536ES1BJP56J	330	P1B	41	1.15	5.30	11.996	115/208-230V	§
1	3600	56J	00136ES1BJP56J	374	P1B	46	1.15	6.30	13.150	115/208-230V	§
1 1/2	3600	56J	00156ES1BJP56J	425	P1B	56	1.15	8.50	13.150	115/208-230V	§
2	3600	56HJ	00236ES1BJP56J	486	P1B	65	1.15	10.5	14.330	115/208-230V	§
3	3600	56HJ	00336ES1DJP56J	557	P1B	78	1.00	13.5	14.724	230V	§

• ELECTRICAL FEATURES ON PAGE B-31. • MECHANICAL FEATURES ON PAGE B-80.

§ = Automatic Thermal Overload

THREADED – LESS BASE – TEFC SINGLE-PHASE

HP	RPM	NEMA Frame	Catalog Number	List Price	Multi. Sym.	Approx. Shipp. Weight Lbs.	Service Factor	FL Amps 230V	“C” Dimension (in.)	Voltage	NOTES
1/3	3600	56J	.3336ES1BJPR56J	296	P1B	36	1.15	2.80	11.996	115/208-230V	§
1/2	3600	56J	.5036ES1BJPR56J	305	P1B	40	1.15	3.80	11.996	115/208-230V	§
3/4	3600	56J	.7536ES1BJPR56J	336	P1B	41	1.15	5.30	11.996	115/208-230V	§
1	3600	56J	00136ES1BJPR56J	386	P1B	46	1.15	6.30	13.150	115/208-230V	§
1 1/2	3600	56J	00156ES1BJPR56J	438	P1B	56	1.15	8.50	13.150	115/208-230V	§
2	3600	56HJ	00236ES1BJPR56J	498	P1B	65	1.15	10.5	14.330	115/208-230V	§
3	3600	56HJ	00336ES1DJPR56J	573	P1B	78	1.00	13.5	14.724	230V	§

• ELECTRICAL FEATURES ON PAGE B-31. • MECHANICAL FEATURES ON PAGE B-80.

KEYED – ‘C’ FACE WITH BASE – TEFC SINGLE-PHASE

HP	RPM	NEMA Frame	Catalog Number	List Price	Multi. Sym.	Approx. Shipp. Weight Lbs.	Service Factor	FL Amps 230V	“C” Dimension (in.)	Voltage	NOTES
1/3	3600	56C	.3336ES1BJP56C	263	P1A	36	1.15	2.80	11.496	115/208-230V	§
1/2	3600	56C	.5036ES1BJP56C	284	P1A	40	1.15	3.80	11.496	115/208-230V	§
3/4	3600	56C	.7536ES1BJP56C	320	P1A	41	1.15	5.30	11.496	115/208-230V	§
1	3600	56C	00136ES1BJP56C	344	P1A	46	1.15	6.30	12.677	115/208-230V	§
1 1/2	3600	56C	00156ES1BJP56C	412	P1A	56	1.15	8.50	12.677	115/208-230V	§
2	3600	56HC	00236ES1BJP56C	487	P1A	65	1.15	10.5	13.858	115/208-230V	§
3	3600	56HC	00336ES1DJP56C*	548	P1A	78	1.00	13.5	14.252	230V	§

• ELECTRICAL FEATURES ON PAGE B-31. • MECHANICAL FEATURES ON PAGE B-80.

KEYED – ‘C’ FACE LESS BASE – TEFC SINGLE-PHASE

HP	RPM	NEMA Frame	Catalog Number	List Price	Multi. Sym.	Approx. Shipp. Weight Lbs.	Service Factor	FL Amps 230V	“C” Dimension (in.)	Voltage	NOTES
1/3	3600	56C	.3336ES1BJPR56C	282	P1A	36	1.15	2.80	11.496	115/208-230V	§
1/2	3600	56C	.5036ES1BJPR56C	299	P1A	40	1.15	3.80	11.496	115/208-230V	§
3/4	3600	56C	.7536ES1BJPR56C	341	P1A	41	1.15	5.30	11.496	115/208-230V	§
1	3600	56C	00136ES1BJPR56C	357	P1A	46	1.15	6.30	12.677	115/208-230V	§
1 1/2	3600	56C	00156ES1BJPR56C	432	P1A	56	1.15	8.50	12.677	115/208-230V	§
2	3600	56HC	00236ES1BJPR56C	494	P1A	65	1.15	10.5	13.858	115/208-230V	§
3	3600	56HC	00336ES1DJPR56C*	555	P1A	78	1.00	13.5	14.252	230V	§

• ELECTRICAL FEATURES ON PAGE B-31. • MECHANICAL FEATURES ON PAGE B-80.

= Automatic Thermal Overload

§

Jet Pump

THREE PHASE

These versatile motors have the torque and durability for the toughest commercial applications, yet are also economical choices for residential applications. The motors are available with or without base and in Form J or C configurations.



ODP



TEFC

APPLICATIONS

- Commercial and Industrial pumps
- Residential pumps
(Jacuzzis, pools, hot tubs)
- Jet pump motor system
- Hydraulic pumps

OPTIONAL FEATURES

- 4 Pole
- Class 'F' insulation
- Special voltages
- Drip cover
- Automatic Overload Protection
- Other mounting configurations

All motors are tested according to IEEE 112 std.
- method "B" or C390 CSA.

STANDARD FEATURES

- Three-phase, 2 pole, 60Hz
- Voltage: 208-230/460V
- Squirrel cage rotor
- Ball bearings
- Fan cooled (internally)
- Service factor according to NEMA standard MG 1-18.329
- Insulation Class 'B' – ODP
- Insulation Class 'F' – TEFC
- Standard: NEMA-MG 1-18.326
- Rotation: Reversible
- Stainless steel shaft end
- Threaded center hole
- Color: Munsell N1 (Black)



- Specially dimensioned shaft
- Second shaft end
- Stainless steel shaft
 - Footless
- Other mounting configuration
- Manual or Automatic thermal overload protection

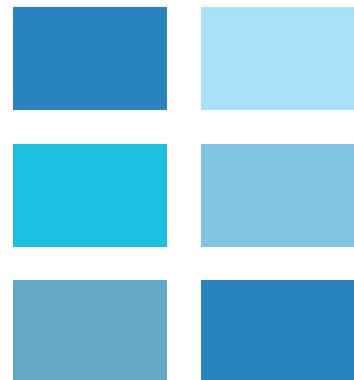

PUMP MOTORS

THREADED – WITH BASE – ODP THREE PHASE

HP	RPM	NEMA Frame	Catalog Number	List Price	Multi. Sym.	Approx. Shipp. Weight Lbs.	Service Factor	FL Amps 230V	"C" Dimension (in.)	Voltage	NOTES
1/3	3600	56J	.33360S3EJP56J	224	P1B	23	1.75	0.75	59.0	10.985	208-230/460V
1/2	3600	56J	.50360S3EJP56J	236	P1B	24	1.60	1.05	61.0	10.985	208-230/460V
3/4	3600	56J	.75360S3EJP56J	271	P1B	26	1.50	1.35	66.0	11.733	208-230/460V
1	3600	56J	001360S3EJP56J	286	P1B	29	1.40	1.65	69.0	11.733	208-230/460V
1 1/2	3600	56J	001560S3EJP56J	296	P1B	34	1.30	2.37	71.2	12.993	208-230/460V
2	3600	56J	002360S3EJP56J	316	P1B	39	1.20	2.85	75.0	12.993	208-230/460V
3	3600	56HJ	003360S3EJP56J	339	P1B	45	1.15	4.05	77.0	14.174	208-230/460V

- ELECTRICAL FEATURES ON PAGE B-31.
- MECHANICAL FEATURES ON PAGE B-79.



THREADED – LESS BASE – ODP THREE PHASE

HP	RPM	NEMA Frame	Catalog Number	List Price	Multi. Sym.	Approx. Shipp. Weight Lbs.	Service Factor	FL Amps 460	“C” Dimension (in.)	Voltage	NOTES
1/3	3600	56J	.33360S3EJPR56J	229	P1B	23	1.75	0.75	10.985	208-230/460V	
1/2	3600	56J	.50360S3EJPR56J	241	P1B	24	1.60	1.05	10.985	208-230/460V	
3/4	3600	56J	.75360S3EJPR56J	278	P1B	26	1.50	1.35	11.733	208-230/460V	
1	3600	56J	001360S3EJPR56J	287	P1B	29	1.40	1.65	11.733	208-230/460V	
1 1/2	3600	56J	001560S3EJPR56J	305	P1B	34	1.30	2.37	12.993	208-230/460V	
2	3600	56J	002360S3EJPR56J	321	P1B	39	1.20	2.85	12.993	208-230/460V	
3	3600	56HJ	003360S3EJPR56J	350	P1B	45	1.15	4.05	14.174	208-230/460V	

- ELECTRICAL FEATURES ON PAGE B-31.
- MECHANICAL FEATURES ON PAGE B-79.



KEYED – C-FACE LESS BASE – ODP THREE PHASE

HP	RPM	NEMA Frame	Catalog Number	List Price	Multi. Sym.	Approx. Shipp. Weight Lbs.	Service Factor	FL Amps 460	“C” Dimension (in.)	Voltage	NOTES
1/3	3600	56C	.33360S3EJPR56C	220	P1A	23	1.75	0.75	10.315	208-230/460V	
1/2	3600	56C	.50360S3EJPR56C	224	P1A	24	1.60	1.05	10.315	208-230/460V	
3/4	3600	56C	.75360S3EJPR56C	257	P1A	26	1.50	1.35	11.103	208-230/460V	
1	3600	56C	001360S3EJPR56C	274	P1A	29	1.40	1.65	11.103	208-230/460V	
1 1/2	3600	56C	001560S3EJPR56C	290	P1A	34	1.30	2.37	12.284	208-230/460V	
2	3600	56C	002360S3EJPR56C	311	P1A	39	1.20	2.85	12.284	208-230/460V	
3	3600	56HC	003360S3EJPR56C	332	P1A	45	1.15	4.05	13.645	208-230/460V	

- ELECTRICAL FEATURES ON PAGE B-31.
- MECHANICAL FEATURES ON PAGE B-80.



THREADED – WITH BASE – TEFC THREE PHASE

HP	RPM	NEMA Frame	Catalog Number	List Price	Multi. Sym.	Approx. Shipp. Weight Lbs.	Service Factor	FL Amps 460	“C” Dimension (in.)	Voltage	NOTES
1/3	3600	56J	.3336ES3EJP56J	259	P1B	33	1.15	0.62	11.996	208-230/460V	
1/2	3600	56J	.5036ES3EJP56J	267	P1B	36	1.15	0.81	11.996	208-230/460V	
3/4	3600	56J	.7536ES3EJP56J	301	P1B	40	1.15	1.09	11.996	208-230/460V	
1	3600	56J	00136ES3EJP56J	344	P1B	44	1.15	1.44	11.996	208-230/460V	
1 1/2	3600	56J	00156ES3EJP56J	374	P1B	48	1.15	1.97	11.996	208-230/460V	
2	3600	56J	00236ES3EJP56J	421	P1B	58	1.15	2.67	13.150	208-230/460V	
3	3600	56HJ	00336ES3EJP56J	489	P1B	67	1.00	3.80	14.330	208-230/460V	

- ELECTRICAL FEATURES ON PAGE B-31.
- MECHANICAL FEATURES ON PAGE B-80.



THREADED – LESS BASE – TEFC THREE PHASE

HP	RPM	NEMA Frame	Catalog Number	List Price	Multi. Sym.	Approx. Shipp. Weight Lbs.	Service Factor	FL Amps 460	“C” Dimension (in.)	Voltage	NOTES
1/3	3600	56J	.3336ES3EJPR56J	268	P1B	33	1.15	0.62	11.996	208-230/460V	
1/2	3600	56J	.5036ES3EJPR56J	282	P1B	36	1.15	0.81	11.996	208-230/460V	
3/4	3600	56J	.7536ES3EJPR56J	319	P1B	40	1.15	1.09	11.996	208-230/460V	
1	3600	56J	00136ES3EJPR56J	346	P1B	44	1.15	1.44	11.996	208-230/460V	
1 1/2	3600	56J	00156ES3EJPR56J	378	P1B	48	1.15	1.97	11.996	208-230/460V	
2	3600	56J	00236ES3EJPR56J	430	P1B	58	1.15	2.67	13.150	208-230/460V	
3	3600	56HJ	00336ES3EJPR56J	503	P1B	67	1.00	3.80	14.330	208-230/460V	

- ELECTRICAL FEATURES ON PAGE B-31.
- MECHANICAL FEATURES ON PAGE B-80.



KEYED – ‘C’ FACE LESS BASE – TEFC THREE PHASE

HP	RPM	NEMA Frame	Catalog Number	List Price	Multi. Sym.	Approx. Shipp. Weight Lbs.	Service Factor	FL Amps 460	“C” Dimension (in.)	Voltage	NOTES
1/3	3600	56C	.3336ES3EJPR56C	257	P1A	33	1.15	0.62	11.496	208-230/460V	
1/2	3600	56C	.5036ES3EJPR56C	270	P1A	36	1.15	0.81	11.496	208-230/460V	
3/4	3600	56C	.7536ES3EJPR56C	293	P1A	40	1.15	1.09	11.496	208-230/460V	
1 1/2	3600	56C	00156ES3EJPR56C	371	P1A	48	1.15	1.97	11.496	208-230/460V	
2	3600	56C	00236ES3EJPR56C	401	P1A	58	1.15	2.67	12.677	208-230/460V	
3	3600	56HC	00336ES3EJPR56C	480	P1A	67	1.00	3.80	13.858	208-230/460V	

- ELECTRICAL FEATURES ON PAGE B-31.
- MECHANICAL FEATURES ON PAGE B-80.



TEFC – SINGLE PHASE

WEG single-phase totally enclosed motors are specifically designed for operating in environments of dirt, dust and excess moisture. Starting capacitors, all cast iron frames, rigid bases, reversible shaft rotation and oversized ball bearings are all standard features. NEMA-T, NEMA 48 & 56 AND IEC METRIC FRAMES ARE ALSO AVAILABLE.

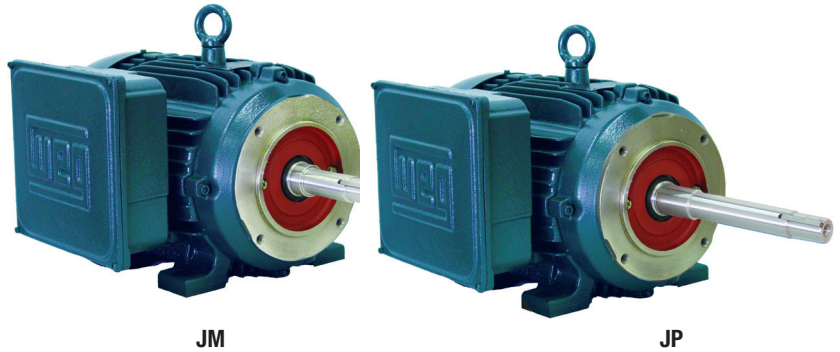

APPLICATIONS

- Pumps

OPTIONAL FEATURES

- Special voltages
- Specially designed shaft
- Second shaft end
- Thermistors or thermostats
- Drip cover (canopy) for shaft down applications
- Stainless steel shaft
- Flange mount

STANDARD FEATURES

- Single-phase, 2 and 4 pole 60Hz
- Voltage: 208-230/460V
- Cast iron frame
- Squirrel cage rotor / Aluminum die cast
- Totally Enclosed Fan Cooled - TEFC (IP55)
- Ball bearings
- NEMA dimensions
- Class 'F' insulation
- Service Factor: 1.15
- Continuous Duty (S1)
- 104°F (40°C) ambient temperature
- Altitude: 3300 ft (1000 m)
- 1045 carbon steel shaft
- F1 mount
- Stainless steel nameplate
- Paint: Enamel alkyd resin base
- Color: RAL 7022 (Dark Gray)
- NPT threaded terminal box
- Automatic drain plugs

All motors are tested according to IEEE 112 Std. – Method 'B' or C390 CSA.

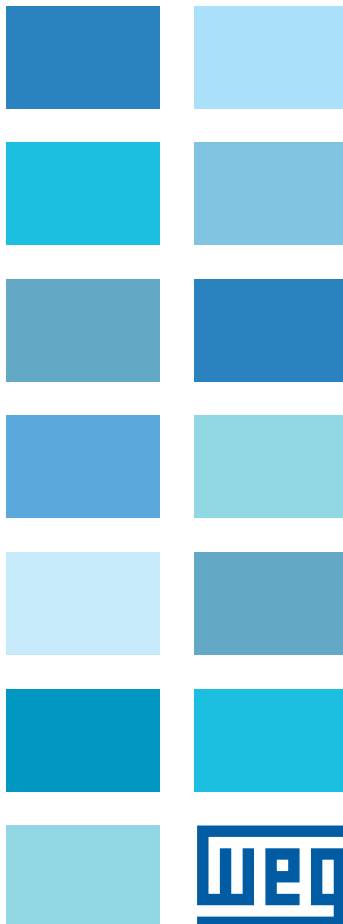

PUMP MOTORS

CLOSE COUPLED PUMP MOTORS

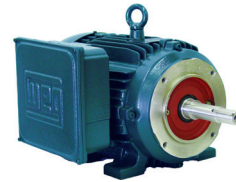

“JM” TYPE – TEFC – SINGLE PHASE

HP	RPM	NEMA Frame	Catalog Number	List Price	Multi. Sym.	Approx. Shipp. Weight Lbs.	FL Amps 460	FL Eff %	“C” Dimension (in.)	Voltage	NOTES
0.5	3600	143JM	.5036ES1E143JM	668	P1	26	1.70	71.3	15.458	208-230/460V	
1	3600	143JM	00136ES1E143JM	682	P1	33	2.90	74.5	15.458	208-230/460V	
	1800	143JM	00118ES1E143JM	687	P1	37	2.85	69.8	15.458	208-230/460V	
1.5	3600	143JM	00156ES1E143JM	729	P1	37	3.60	81.3	15.458	208-230/460V	
	1800	145JM	00158ES1E145JM	754	P1	49	3.50	76.8	16.458	208-230/460V	
2	3600	145JM	00236ES1E145JM	770	P1	45	4.45	86.2	16.458	208-230/460V	
	1800	145JM	00218ES1E145JM	814	P1	54	4.50	79.6	16.458	208-230/460V	
3	3600	145JM	00336ES1E145JM	1,076	P1	52	6.50	80.0	16.458	208-230/460V	
	3600	145JM	00336ES1C145JM	1,076	P1	52	6.50	80.0	16.458	208-230V	
	1800	184JM	00318ES1E184JM	1,182	P1	131	7.25	77.2	17.368	208-230/460V	
5	3600	184JM	00536ES1E184JM	1,457	P1	115	10.5	83.0	17.368	208-230/460V	
	3600	184JM	00536ES1C184JM	1,457	P1	115	10.5	83.0	17.368	208-230V	
	1800	184JM	00518ES1E184JM	1,430	P1	153	10.5	79.4	17.368	208-230/460V	
7.5	3600	213JM	00736ES1E213JM	1,641	P1	139	16.0	84.0	18.904	208-230/460V	
	3600	213JM	00736ES1C213JM	1,641	P1	139	16.0	84.0	18.904	208-230V	
	1800	215JM	00718ES1E215JM	1,762	P1	168	17.0	82.0	20.400	208-230/460V	
10	3600	215JM	01036ES1E215JM	2,172	P1	172	19.5	86.3	20.400	208-230/460V	
	3600	215JM	01036ES1C215JM	2,172	P1	172	19.5	86.3	20.400	208-230V	
	1800	215JM	01018ES1E215JM	2,057	P1	179	20.0	83.0	20.400	208-230/460V	

- ELECTRICAL FEATURES ON PAGE B-32.
- MECHANICAL FEATURES ON PAGE B-83.

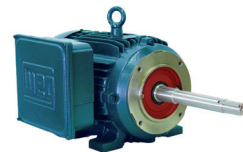

PUMP MOTORS

“JP” TYPE – TEFC – SINGLE PHASE

HP	RPM	NEMA Frame	Catalog Number	List Price	Multi. Sym.	Approx. Shipp. Weight Lbs.	FL Amps 460	FL Eff %	“C” Dimension (in.)	Voltage	NOTES
0.5	3600	143JP	.5036ES1E143JP	668	P1	26	1.70	71.3	18.519	208-230/460V	
1	1800	143JP	00118ES1E143JP	687	P1	37	2.85	69.8	18.519	208-230/460V	
1.5	3600	143JP	00156ES1E143JP	729	P1	37	3.60	81.3	18.519	208-230/460V	
	1800	145JP	00158ES1E145JP	754	P1	49	3.50	76.8	19.519	208-230/460V	
2	3600	145JP	00236ES1E145JP	770	P1	45	4.45	86.2	19.519	208-230/460V	
	1800	145JP	00218ES1E145JP	814	P1	54	4.50	79.6	19.519	208-230/460V	
3	3600	145JP	00336ES1E145JP	1,076	P1	52	6.50	80.0	19.519	208-230/460V	
	1800	184JP	00318ES1E184JP	1,182	P1	131	7.25	77.2	20.429	208-230/460V	
5	3600	184JP	00536ES1E184JP	1,457	P1	115	10.5	83.0	20.429	208-230/460V	
	1800	184JP	00518ES1E184JP	1,430	P1	153	10.5	79.4	20.429	208-230/460V	
7.5	3600	213JP	00736ES1E213JP	1,641	P1	139	16.0	84.0	22.776	208-230/460V	
	1800	215JP	00718ES1E215JP	1,762	P1	168	17.0	82.0	24.272	208-230/460V	
10	3600	215JP	01036ES1E215JP	2,172	P1	172	19.5	86.3	24.272	208-230/460V	
	1800	215JP	01018ES1E215JP	2,057	P1	179	20.0	83.0	24.272	208-230/460V	

- ELECTRICAL FEATURES ON PAGE B-32.
- MECHANICAL FEATURES ON PAGE B-83.



Pump Motors

Close Coupled - Standard Efficiency

ODP – THREE PHASE

WEG offers both JM and JP standardized types of ODP close coupled pump line of motors. Remember that ODP are suitable where dirt and moisture are at a minimum.

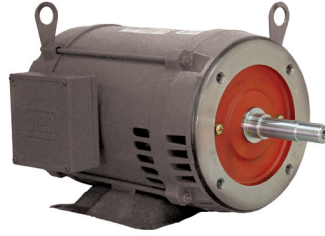

JM

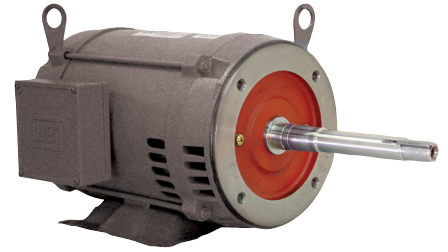

JP



APPLICATIONS

Specially developed line for industrial and commercial pumping applications.

- Water pumping
- Process
- Transfer and circulating pumps

OPTIONAL FEATURES

- Cable glands
- Special Voltages
- Cast iron NEMA C-flange or D-flange (D-flange only for frames 254T and up)
- Special designed shaft
- Second shaft end
- Thermistors, Thermostats or RTD's (PT100)
- Roller bearing on drive end
- IEC metric frames (on request) for frame 254T up to 445T
- Stainless steel shaft
- Class H insulation
- Design C
- 575V

STANDARD FEATURES

- Single-phase, 2, 4 or 6 pole, 60Hz
- Voltage: 115/208-230V
- Squirrel cage rotor
- Start capacitor
- NEMA dimensions
- Class 'B' insulation (130°C)
- High starting torque
- Ball Bearings
- Open drip proof (ODP - IP21)
- Totally enclosed fan cooled (TEFC - IP55)
- Color: RAL 7022 (Dark Gray)
- Continuous Duty (S1), 40°C ambient
- V-ring slingers on both endshields (for TEFC only)
- Designed to operate in any position (for TEFC only)

ALL MOTORS ARE TESTED ACCORDING TO IEEE 112 STD. - METHOD 'B' OR C390 CSA



FRAME – SPECIFIC FEATURES

FOR FRAME 143/5JM/JP, ONLY

- Welded steel plate frames (welded feet)
- Cast iron endshields fixed with through bolt construction
- 'ZZ' bearings (double shielded)
- Degree of protection: IP21

- Cooling system with finned rotor
- Cast iron endshields fixed with through bolt construction
- "ZZ" bearings (double shielded)
- Degree of protection: IP21

FOR FRAME 182JM up to 215JM

- Welded steel plate frames (welded feet)
- Aluminum endshields and Terminal box

FOR FRAME 254JM UP TO 445JM

- Cast iron frames
- Cast iron endshields and terminal box
- Cooling system with finned rotor
- Regreasable bearings positive pressure lubrication system (frame 254T and up)
- Degree of protection: IP23

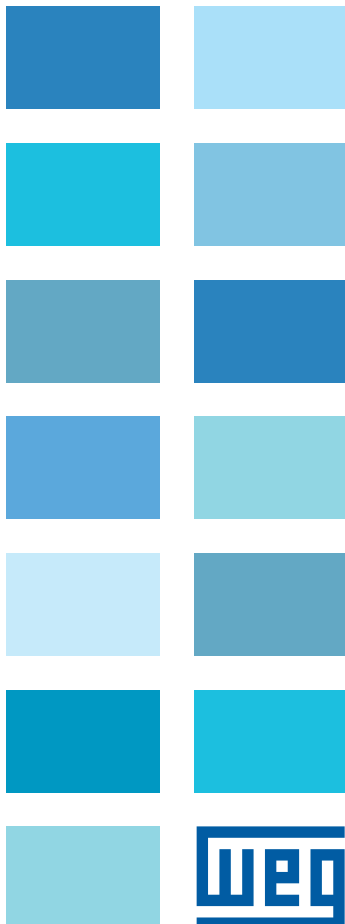

PUMP MOTORS

CLOSE COUPLED PUMP MOTORS

STANDARD EFFICIENCY



“JM” TYPE – ODP – THREE-PHASE

HP	RPM	NEMA Frame	Catalog Number	List Price	Multi. Sym.	Approx. Shipp. Weight Lbs.	FL Amps 460	FL Eff %	“C” Dimension (in.)	Voltage	NOTES
1	1800	143JM	001180S3E143JM	379	P1C	36	1.52	78.5	14.055	208-230/460V	
1.5	3600	143JM	001560S3E143JM	400	P1C	32	2.07	78.5	14.055	208-230/460V	
	1800	145JM	001580S3E145JM	414	P1C	41	2.19	77.0	14.055	208-230/460V	
2	3600	145JM	002360S3E145JM	432	P1C	43	2.71	80.0	14.055	208-230/460V	
	1800	145JM	002180S3E145JM	433	P1C	43	2.72	82.5	14.055	208-230/460V	
3	3600	145JM	003360S3E145JM	482	P1C	49	3.92	80.0	14.055	208-230/460V	
	1800	182JM	003180S3E182JM	507	P1C	56	3.94	82.5	14.527	208-230/460V	
5	3600	182JM	005360S3E182JM	628	P1C	57	6.15	85.5	14.527	208-230/460V	
	1800	184JM	005180S3E184JM	652	P1C	69	6.50	84.0	15.315	208-230/460V	
7.5	3600	184JM	007360S3E184JM	785	P1C	69	8.85	86.5	15.315	208-230/460V	
	1800	213JM	007180S3E213JM	886	P1C	85	9.75	87.5	17.323	208-230/460V	
10	3600	213JM	010360S3E213JM	1,007	P1C	108	12.1	87.5	17.323	208-230/460V	
	1800	215JM	010180S3E215JM	1,078	P1C	109	12.5	86.5	17.323	208-230/460V	
15	3600	215JM	015360S3E215JM	1,264	P1C	139	18.0	85.5	17.323	208-230/460V	
	1800	254JM	015180S3E254JM	1,513	P1C	194	20.0	87.5	22.169	208-230/460V	
20	3600	254JM	020360S3E254JM	1,571	P1C	213	25.5	86.8	22.169	208-230/460V	
	1800	256JM	020180S3E256JM	1,825	P1C	258	26.3	88.5	23.902	208-230/460V	
25	3600	256JM	025360S3E256JM	1,941	P1C	262	30.2	88.5	23.902	208-230/460V	
	1800	284JM	025180S3E284JM	2,209	P1C	300	30.3	90.2	24.261	208-230/460V	
30	3600	284JM	030360S3E284JM	2,365	P1C	300	37.2	89.5	24.261	208-230/460V	
	1800	286JM	030180S3E286JM	2,549	P1C	346	36.3	89.5	25.754	208-230/460V	
40	3600	286JM	040360S3E286JM	2,822	P1C	388	47.5	90.2	25.754	208-230/460V	
	1800	324JM	040180S3E324JM	2,824	P1C	424	52.0	90.2	26.431	208-230/460V	
50	3600	324JM	050360S3E324JM	3,610	P1C	471	57.0	92.4	26.431	208-230/460V	
	1800	326JM	050180S3E326JM	3,553	P1C	515	64.0	91.0	27.927	208-230/460V	
60	3600	326JM	060360S3E326JM	4,208	P1C	552	69.5	92.4	27.927	208-230/460V	
	1800	364JM	060180S3E364JM	4,549	P1C	705	73.4	91.6	29.139	208-230/460V	
75	3600	364JM	075360S3E364JM	5,390	P1C	681	84.0	93.0	29.139	208-230/460V	
	1800	365JM	075180S3E365JM	5,185	P1C	749	88.6	91.7	29.139	208-230/460V	
100	3600	365JM	100360S3E365JM	6,368	P1C	727	112	93.0	29.139	208-230/460V	

- ELECTRICAL FEATURES ON PAGE B-32.
- MECHANICAL FEATURES ON PAGE B-81, B-82.

PUMP MOTORS

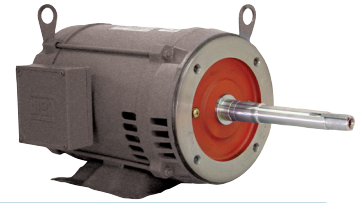

“JP” TYPE – ODP – THREE-PHASE

HP	RPM	NEMA Frame	Catalog Number	List Price	Multi. Sym.	Approx. Shipp. Weight Lbs.	FL Amps 460	FL Eff %	“C” Dimension (in.)	Voltage	NOTES
1	1800	143JP	001180S3E143JP	379	P1C	36	1.52	78.5	17.126	208-230/460V	
	3600	143JP	001560S3E143JP	400	P1C	32	2.07	78.5	17.126	208-230/460V	
1.5	1800	145JP	001580S3E145JP	414	P1C	41	2.19	77.0	17.126	208-230/460V	
	3600	145JP	002360S3E145JP	432	P1C	43	2.71	80.0	17.126	208-230/460V	
2	1800	145JP	002180S3E145JP	433	P1C	43	2.72	82.5	17.126	208-230/460V	
	3600	145JP	003360S3E145JP	482	P1C	49	3.92	80.0	17.126	208-230/460V	
3	1800	182JP	003180S3E182JP	507	P1C	56	3.94	82.5	20.236	208-230/460V	
	3600	182JP	005360S3E182JP	628	P1C	57	6.15	85.5	20.236	208-230/460V	
5	1800	184JP	005180S3E184JP	652	P1C	69	6.5	84.0	21.023	208-230/460V	
	3600	184JP	007360S3E184JP	785	P1C	69	8.85	86.5	21.023	208-230/460V	
7.5	1800	213JP	007180S3E213JP	886	P1C	85	9.75	87.5	21.240	208-230/460V	
	3600	213JP	010360S3E213JP	1,007	P1C	108	12.1	87.5	21.240	208-230/460V	
10	1800	215JP	010180S3E215JP	1,078	P1C	109	12.5	86.5	21.240	208-230/460V	
	3600	215JP	015360S3E215JP	1,264	P1C	139	18.0	85.5	21.240	208-230/460V	
15	1800	254JP	015180S3E254JP	1,513	P1C	194	20.0	87.5	25.049	208-230/460V	
	3600	254JP	020360S3E254JP	1,571	P1C	213	25.5	86.8	25.049	208-230/460V	
20	1800	256JP	020180S3E256JP	1,825	P1C	258	26.3	88.5	26.782	208-230/460V	
	3600	256JP	025360S3E256JP	1,941	P1C	262	30.2	88.5	26.782	208-230/460V	
25	1800	284JP	025180S3E284JP	2,209	P1C	300	30.3	90.2	27.141	208-230/460V	
	3600	284JP	030360S3E284JP	2,365	P1C	300	37.2	89.5	27.141	208-230/460V	
30	1800	286JP	030180S3E286JP	2,549	P1C	346	36.3	89.5	28.634	208-230/460V	
	3600	286JP	040360S3E286JP	2,822	P1C	388	47.5	90.2	28.634	208-230/460V	
40	1800	324JP	040180S3E324JP	2,810	P1C	424	52.0	90.2	29.311	208-230/460V	
	3600	324JP	050360S3E324JP	3,610	P1C	471	57.0	92.4	29.311	208-230/460V	
50	1800	326JP	050180S3E326JP	3,553	P1C	515	64.0	91.0	30.807	208-230/460V	
	3600	326JP	060360S3E326JP	4,208	P1C	552	69.5	92.4	30.807	208-230/460V	
60	1800	364JP	060180S3E364JP	4,549	P1C	705	73.4	91.6	32.019	208-230/460V	
	3600	364JP	075360S3E364JP	5,390	P1C	681	84.0	93.0	32.019	208-230/460V	
75	1800	365JP	075180S3E365JP	5,185	P1C	749	88.6	91.7	32.019	208-230/460V	
	3600	365JP	100180S3E404JP	6,468	P1C	828	121	92.4	35.263	208-230/460V	

- ELECTRICAL FEATURES ON PAGE B-32.
- MECHANICAL FEATURES ON PAGE B-81, B-82.

PUMP MOTORS

CLOSE COUPLED PUMP MOTORS

STANDARD EFFICIENCY



“JM” TYPE – ODP – VERTICAL MOTORS

HP	RPM	NEMA Frame	Catalog Number	List Price	Multi. Sym.	Approx. Shipp. Weight Lbs.	FL Amps 460	FL Eff %	“C” Dimension (in.)	Voltage	NOTES
1	1800	143JMV	001180S3E143JMV	454	P1	36	1.52	78.5	15.196	208-230/460V	
1.5	1800	145JMV	001580S3E145JMV	486	P1	41	2.19	77.0	15.196	208-230/460V	
2	1800	145JMV	002180S3E145JMV	505	P1	43	2.72	82.5	15.196	208-230/460V	
3	1800	182JMV	003180S3E182JMV	637	P1	56	3.94	82.5	15.904	208-230/460V	
5	3600	182JMV	005360S3E182JMV	758	P1	57	6.15	85.5	15.904	208-230/460V	
	1800	184JMV	005180S3E184JMV	783	P1	69	6.50	84.0	16.692	208-230/460V	
7.5	3600	184JMV	007360S3E184JMV	915	P1	69	8.85	86.5	16.692	208-230/460V	
	1800	213JMV	007180S3E213JMV	1,051	P1	85	9.75	87.5	18.700	208-230/460V	
10	3600	213JMV	010360S3E213JMV	1,172	P1	108	12.1	87.5	18.700	208-230/460V	
	1800	215JMV	010180S3E215JMV	1,243	P1	109	12.5	86.5	18.700	208-230/460V	
15	3600	215JMV	015360S3E215JMV	1,428	P1	139	18.0	85.5	18.700	208-230/460V	
20	3600	254JMV	020360S3E254JMV	1,835	P1	213	25.5	86.8	23.507	208-230/460V	
25	3600	256JMV	025360S3E256JMV	2,205	P1	262	30.2	88.5	23.902	208-230/460V	
40	3600	286JMV	040360S3E286JMV	3,156	P1	388	47.5	90.2	27.368	208-230/460V	
50	3600	324JMV	050360S3E324JMV	4,032	P1	471	57.0	92.4	29.147	208-230/460V	

- ELECTRICAL FEATURES ON PAGE B-32.
- MECHANICAL FEATURES ON PAGE B-81, B-82.



PUMP MOTORS

“JP” TYPE – ODP – VERTICAL MOTORS

HP	RPM	NEMA Frame	Catalog Number	List Price	Multi. Sym.	Approx. Shipp. Weight Lbs.	FL Amps 460	FL Eff %	“C” Dimension (in.)	Voltage	NOTES
1.5	3600	143JPV	001560S3E143JPV	486	P1	32	2.07	78.5	17.126	208-230/460V	
2	3600	145JPV	002360S3E145JPV	518	P1	43	2.71	80.0	17.126	208-230/460V	
3	3600	145JPV	003360S3E145JPV	613	P1	49	3.92	80.0	17.126	208-230/460V	
5	3600	182JPV	005360S3E182JPV	783	P1	57	6.15	85.5	20.236	208-230/460V	
7.5	3600	184JPV	007360S3E184JPV	915	P1	69	8.85	86.5	22.400	208-230/460V	
10	3600	213JPV	010360S3E213JPV	1,172	P1	108	12.1	87.5	22.617	208-230/460V	
15	3600	215JPV	015360S3E215JPV	1,428	P1	139	18.0	85.5	22.617	208-230/460V	
20	3600	254JPV	020360S3E254JPV	1,835	P1	213	25.5	86.8	26.387	208-230/460V	
25	3600	256JPV	025360S3E256JPV	2,205	P1	262	30.2	88.5	26.782	208-230/460V	
30	3600	284JPV	030360S3E284JPV	2,699	P1	300	37.2	89.5	28.755	208-230/460V	
40	3600	286JPV	040360S3E286JPV	3,156	P1	388	47.5	90.2	30.248	208-230/460V	
50	3600	324JPV	050360S3E324JPV	4,032	P1	471	57.0	92.4	29.311	208-230/460V	

- ELECTRICAL FEATURES ON PAGE B-32.
- MECHANICAL FEATURES ON PAGE B-81, B-82.



Pump Motors

Close Coupled - High Efficiency

ODP – THREE PHASE

WEG offers both JM and JP standardized types of ODP close coupled pump line of motors. Remember that ODP are suitable where dirt and moisture are at a minimum.

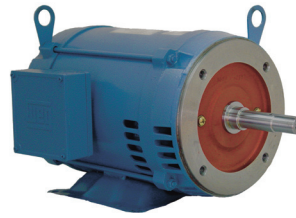

JM

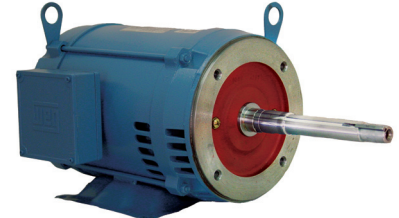

JP

HIGHLIGHTS

- VFD Capable
- Cast Iron Flange

APPLICATIONS

Specially developed line for industrial and commercial pumping applications.

- Water pumping
- Process
- Transfer and circulating pumps

OPTIONAL FEATURES

- Cable glands
- Special Voltages
- Cast iron NEMA C-flange or D-flange (D-flange only for frames 254T and up)
- Special designed shaft
- Second shaft end
- Thermistors, Thermostats or RTD's (PT100)
- Roller bearing on drive end
- IEC metric frames (on request) for frame 254T up to 445T
- Stainless steel shaft
- Class H insulation
- Design C
- 575V

STANDARD FEATURES

- 3 phase, 2, 4 and 6 pole, 60Hz
- Voltage: 208-230/460V, 460V
- Squirrel cage rotor / Aluminum die cast
- Open drip proof design
- NEMA dimensions
- Service factor: 1.15
- Class 'F' insulation
- Temperature rise: Class 'B' (80°C)
- Continuous Duty (S1)
- 104°F (40°C) ambient temperature
- 1045 carbon steel shaft
- F1 mount (with cast iron 'C' Flange)
- Paint: Enamel alkyd resin base
- Color: RAL 5009 (Blue)
- NPT threaded holes in T-Box
- Stainless steel nameplate

ALL MOTORS ARE TESTED ACCORDING TO IEEE 112 STD. - METHOD 'B' OR C390 CSA



FRAME – SPECIFIC FEATURES

FOR FRAME 143/5JM/JP, ONLY

- Welded steel plate frames (welded feet)
- Cast iron endshields fixed with through bolt construction
- 'ZZ' bearings (double shielded)
- Degree of protection: IP21

FOR FRAME 182JM up to 215JM

- Welded steel plate frames (welded feet)
- Aluminum endshields and Terminal box
- Cooling system with finned rotor

- Cast iron endshields fixed with through bolt construction
- "ZZ" bearings (double shielded)
- Degree of protection: IP21

FOR FRAME 254JM UP TO 445JM

- Cast iron frames
- Cast iron endshields and terminal box
- Cooling system with finned rotor
- Regreasable bearings system (frame 254JM and up)
- Degree of protection: IP23

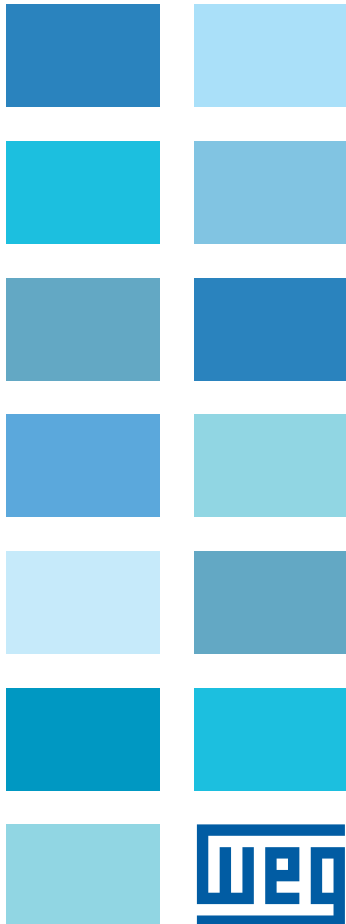

PUMP MOTORS

CLOSE COUPLED PUMP MOTORS

HIGH EFFICIENCY

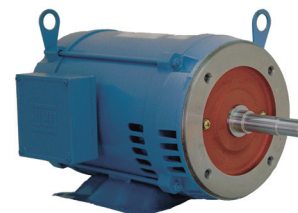

“JM” TYPE – ODP – THREE-PHASE

HP	RPM	NEMA Frame	Catalog Number	List Price	Multi. Sym.	Approx. Shipp. Weight Lbs.	FL Amps 460	FL Eff %	“C” Dimension (in.)	Voltage	NOTES
1	1800	143JM	001180P3E143JM	437	P1C	36	1.41	82.5	14.055	208-230/460V	
1.5	3600	143JM	001560P3E143JM	453	P1C	32	1.95	82.5	14.055	208-230/460V	
	1800	145JM	001580P3E145JM	478	P1C	40	1.98	84.0	14.055	208-230/460V	
2	3600	145JM	002360P3E145JM	498	P1C	43	2.52	84.0	14.055	208-230/460V	
	1800	145JM	002180P3E145JM	524	P1C	43	2.87	84.0	14.055	208-230/460V	
3	3600	145JM	003360P3E145JM	565	P1C	49	3.65	84.0	14.055	208-230/460V	
	1800	182JM	003180P3E182JM	557	P1C	56	3.94	86.5	14.527	208-230/460V	
5	3600	182JM	005360P3E182JM	669	P1C	57	6.17	86.5	14.527	208-230/460V	
	1800	184JM	005180P3E184JM	740	P1C	69	6.39	87.5	15.315	208-230/460V	
7.5	3600	184JM	007360P3E184JM	862	P1C	69	8.97	87.5	15.315	208-230/460V	
	1800	213JM	007180P3E213JM	945	P1C	85	9.40	88.5	17.323	208-230/460V	
10	3600	213JM	010360P3E213JM	1,109	P1C	108	11.8	88.5	17.323	208-230/460V	
	1800	215JM	010180P3E215JM	1,161	P1C	109	12.7	89.5	17.323	208-230/460V	
15	3600	215JM	015360P3E215JM	1,447	P1C	139	17.1	89.5	17.323	208-230/460V	
	1800	254JM	015180P3E254JM	1,749	P1C	247	18.7	91.0	22.169	208-230/460V	
20	3600	254JM	020360P3E254JM	1,816	P1C	205	24.6	90.2	22.169	208-230/460V	
	1800	256JM	020180P3E256JM	2,107	P1C	277	25.2	91.0	23.902	208-230/460V	
25	3600	256JM	025360P3E256JM	2,242	P1C	251	29.3	91.0	23.902	208-230/460V	
	1800	284JM	025180P3E284JM	2,551	P1C	311	30.1	91.7	24.261	208-230/460V	
30	3600	284JM	030360P3E284JM	2,731	P1C	373	34.0	92.4	24.261	208-230/460V	
	1800	286JM	030180P3E286JM	2,946	P1C	397	35.6	92.4	25.754	208-230/460V	
40	3600	286JM	040360P3E286JM	3,260	P1C	457	44.8	92.4	25.754	208-230/460V	
	1800	324JM	040180P3E324JM	3,354	P1C	495	48.2	93.0	26.431	208-230/460V	
50	3600	324JM	050360P3E324JM	3,971	P1C	523	56.4	93.6	26.431	208-230/460V	
	1800	326JM	050180P3E326JM	4,104	P1C	583	60.2	93.0	27.927	208-230/460V	
60	3600	326JM	060360P3E326JM	4,859	P1C	609	70.6	93.0	27.927	208-230/460V	
	3600	326JM	060360P3G326JM	4,859	P1C	609	70.6	93.0	27.927	460V	
	1800	364JM	060180P3E364JM	5,254	P1C	743	70.2	93.6	29.139	208-230/460V	
	1800	364JM	060180P3G364JM	5,254	P1C	743	70.2	93.6	29.139	460V	
75	3600	364JM	075360P3E364JM	6,226	P1C	805	80.6	94.1	29.139	208-230/460V	
	3600	364JM	075360P3G364JM	6,226	P1C	805	80.6	94.1	29.139	460V	
	1800	365JM	075180P3E365JM	5,989	P1C	935	85.3	94.1	29.139	208-230/460V	
	1800	365JM	075180P3G365JM	5,989	P1C	935	85.3	94.1	29.139	460V	
100	3600	365JM	100360P3E365JM	7,005	P1C	935	110	94.1	29.139	208-230/460V	
	3600	365JM	100360P3G365JM	7,005	P1C	935	110	94.1	29.139	460V	

- ELECTRICAL FEATURES ON PAGE B-8, B-9.
- MECHANICAL FEATURES ON PAGE B-81, B-82.

PUMP MOTORS

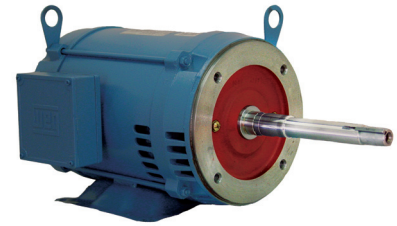

“JP” TYPE – ODP – THREE-PHASE

HP	RPM	NEMA Frame	Catalog Number	List Price	Multi. Sym.	Approx. Shipp. Weight Lbs.	FL Amps 460	FL Eff %	“C” Dimension (in.)	Voltage	NOTES
1	1800	143JP	001180P3E143JP	437	P1C	36	1.41	82.5	17.126	208-230/460V	
1.5	3600	143JP	001560P3E143JP	453	P1C	32	1.95	82.5	17.126	208-230/460V	
	1800	145JP	001580P3E145JP	478	P1C	40	1.98	84.0	17.126	208-230/460V	
2	3600	145JP	002360P3E145JP	498	P1C	43	2.52	84.0	17.126	208-230/460V	
	1800	145JP	002180P3E145JP	524	P1C	43	2.87	84.0	17.126	208-230/460V	
3	3600	145JP	003360P3E145JP	565	P1C	49	3.65	84.0	17.126	208-230/460V	
	1800	182JP	003180P3E182JP	557	P1C	56	3.94	86.5	20.236	208-230/460V	
5	3600	182JP	005360P3E182JP	669	P1C	57	6.17	86.5	20.236	208-230/460V	
	1800	184JP	005180P3E184JP	739	P1C	69	6.39	87.5	21.023	208-230/460V	
7.5	3600	184JP	007360P3E184JP	862	P1C	69	8.97	87.5	21.023	208-230/460V	
	1800	213JP	007180P3E213JP	946	P1C	85	9.40	88.5	21.240	208-230/460V	
10	3600	213JP	010360P3E213JP	1,109	P1C	108	11.8	88.5	21.240	208-230/460V	
	1800	215JP	010180P3E215JP	1,163	P1C	109	12.7	89.5	21.240	208-230/460V	
15	3600	215JP	015360P3E215JP	1,447	P1C	139	17.1	89.5	21.240	208-230/460V	
	1800	254JP	015180P3E254JP	1,749	P1C	247	18.7	91.0	25.049	208-230/460V	
20	3600	254JP	020360P3E254JP	1,815	P1C	205	24.6	90.2	25.049	208-230/460V	
	1800	256JP	020180P3E256JP	2,107	P1C	277	25.2	91.0	26.782	208-230/460V	
25	3600	256JP	025360P3E256JP	2,243	P1C	251	29.3	91.0	26.782	208-230/460V	
	1800	284JP	025180P3E284JP	2,550	P1C	311	30.1	91.7	27.141	208-230/460V	
30	3600	284JP	030360P3E284JP	2,731	P1C	373	34.0	92.4	27.141	208-230/460V	
	1800	286JP	030180P3E286JP	2,945	P1C	397	35.6	92.4	28.634	208-230/460V	
40	3600	286JP	040360P3E286JP	3,260	P1C	457	44.8	92.4	28.634	208-230/460V	
	1800	324JP	040180P3E324JP	3,354	P1C	495	48.2	93.0	29.311	208-230/460V	
50	3600	324JP	050360P3E324JP	3,971	P1C	523	56.4	93.6	29.311	208-230/460V	
	3600	324JP	050360P3G324JP	3,971	P1C	523	56.4	93.6	29.311	460V	
	1800	326JP	050180P3E326JP	4,105	P1C	583	60.2	93.0	30.807	208-230/460V	
60	3600	326JP	060360P3E326JP	4,859	P1C	609	70.6	93.0	30.807	208-230/460V	
	3600	326JP	060360P3G326JP	4,859	P1C	609	70.6	93.0	30.807	460V	
	1800	364JP	060180P3E364JP	5,254	P1C	743	70.2	93.6	32.019	208-230/460V	
	1800	364JP	060180P3G364JP	5,254	P1C	743	70.2	93.6	32.019	460V	
75	3600	364JP	075360P3E364JP	6,226	P1C	805	80.6	94.1	32.019	208-230/460V	
	3600	364JP	075360P3G364JP	6,226	P1C	805	80.6	94.1	32.019	460V	
	1800	365JP	075180P3E365JP	5,989	P1C	935	85.3	94.1	32.019	208-230/460V	
	1800	365JP	075180P3G365JP	5,989	P1C	935	85.3	94.1	32.019	460V	
100	3600	365JP	100360P3E365JP	7,005	P1C	935	110.0	94.1	32.019	208-230/460V	
	3600	365JP	100360P3G365JP	7,005	P1C	935	110	94.1	32.019	460V	
	1800	404JP	100180P3E404JP	7,469	P1C	1037	115	94.1	35.263	208-230/460V	
	1800	404JP	100180P3G404JP	7,469	P1C	1037	115	94.1	35.263	460V	
125	3600	404JP	125360P3G404JP	9,185	P1C	1086	132	94.1	35.263	460V	
	1800	405JP	125180P3G405JP	8,971	P1C	1207	137	94.5	35.263	460V	
150	3600	405JP	150360P3G405JP	12,106	P1C	1401	159	94.5	35.263	460V	

- ELECTRICAL FEATURES ON PAGE B-8, B-9.
- MECHANICAL FEATURES ON PAGE B-81, B-82.

PUMP MOTORS

CLOSE COUPLED PUMP MOTORS

ODP – HIGH EFFICIENCY



“JM” TYPE – ODP – VERTICAL MOTORS

HP	RPM	NEMA Frame	Catalog Number	List Price	Multi. Sym.	Approx. Shipp. Weight Lbs.	FL Amps 460	FL Eff %	“C” Dimension (in.)	Voltage	NOTES
1	1800	143JMV	001180P3E143JMV	513	P1C	36	1.41	82.5	14.756	208-230/460V	
1.5	3600	143JMV	001560P3E143JMV	542	P1C	32	1.95	82.5	14.756	208-230/460V	
	1800	145JMV	001580P3E145JMV	554	P1C	40	1.98	84.0	14.756	208-230/460V	
2	3600	145JMV	002360P3E145JMV	573	P1C	43	2.52	84.0	14.756	208-230/460V	
	1800	145JMV	002180P3E145JMV	603	P1C	43	2.87	84.0	14.756	208-230/460V	
3	3600	145JMV	003360P3E145JMV	657	P1C	49	3.65	84.0	14.756	208-230/460V	
	1800	182JMV	003180P3E182JMV	687	P1C	56	3.94	86.5	15.314	208-230/460V	
5	3600	182JMV	005360P3E182JMV	797	P1C	57	6.17	86.5	15.314	208-230/460V	
	1800	184JMV	005180P3E184JMV	875	P1C	69	6.39	87.5	15.314	208-230/460V	
7.5	3600	184JMV	007360P3E184JMV	993	P1C	69	8.97	87.5	15.314	208-230/460V	
	1800	213JMV	007180P3E213JMV	1,106	P1C	85	9.40	88.5	18.700	208-230/460V	
10	3600	213JMV	010360P3E213JMV	1,201	P1C	108	11.8	88.5	18.700	208-230/460V	
	1800	215JMV	010180P3E215JMV	1,323	P1C	109	12.7	89.5	18.700	208-230/460V	
15	3600	215JMV	015360P3E215JMV	1,617	P1C	139	17.1	89.5	18.700	208-230/460V	
20	3600	254JMV	020360P3E254JMV	2,092	P1C	205	24.6	90.2	22.169	208-230/460V	
25	3600	256JMV	025360P3E256JMV	2,518	P1C	251	29.3	91.0	23.902	208-230/460V	
30	3600	284JMV	030360P3E284JMV	3,082	P1C	373	34.0	92.4	24.261	208-230/460V	
40	3600	286JMV	040360P3E286JMV	3,611	P1C	457	44.8	92.4	25.754	208-230/460V	
50	3600	324JMV	050360P3E324JMV	4,394	P1C	523	56.4	93.6	26.431	208-230/460V	

Note: Prices with Drip Cover Included

- ELECTRICAL FEATURES ON PAGE B-8, B-9.
- MECHANICAL FEATURES ON PAGE B-81, B-82.



PUMP MOTORS

“JP” TYPE – ODP – VERTICAL MOTORS

HP	RPM	NEMA Frame	Catalog Number	List Price	Multi. Sym.	Approx. Shipp. Weight Lbs.	FL Amps 460	FL Eff %	“C” Dimension (in.)	Voltage	NOTES
1.5	3600	143JPV	001560P3E143JPV	513	P1C	32	1.95	82.5	17.827	208-230/460V	
2	3600	145JPV	002360P3E145JPV	559	P1C	43	2.52	84.0	17.827	208-230/460V	
3	3600	145JPV	003360P3E145JPV	629	P1C	49	3.65	84.0	17.827	208-230/460V	
5	3600	182JPV	005360P3E182JPV	729	P1C	57	6.17	86.5	22.400	208-230/460V	
7.5	3600	184JPV	007360P3E184JPV	993	P1C	69	9.0	87.5	22.400	208-230/460V	
10	3600	213JPV	010360P3E213JPV	1,273	P1C	108	11.8	88.5	22.617	208-230/460V	
15	3600	215JPV	015360P3E215JPV	1,617	P1C	139	17.1	89.5	22.617	208-230/460V	
20	3600	254JPV	020360P3E254JPV	2,092	P1C	205	24.6	90.2	26.387	208-230/460V	
25	3600	256JPV	025360P3E256JPV	2,518	P1C	251	29.3	91.0	26.782	208-230/460V	
30	3600	284JPV	030360P3E284JPV	3,082	P1C	373	34	92.4	28.755	208-230/460V	
40	3600	286JPV	040360P3E286JPV	3,611	P1C	457	44.8	92.4	30.248	208-230/460V	

Note: Prices with Drip Cover Included

- ELECTRICAL FEATURES ON PAGE B-8, B-9.
- MECHANICAL FEATURES ON PAGE B-81, B-82.



Pump Motors

Close Coupled - ODP - NEMA PREMIUM

ODP – THREE PHASE

WEG offers both JM and JP standardized types of ODP close coupled pump line of motors. Remember that ODP are suitable where dirt and moisture are at a minimum.

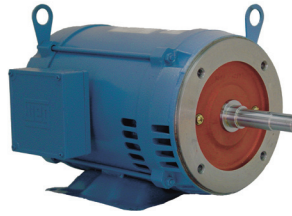

JM

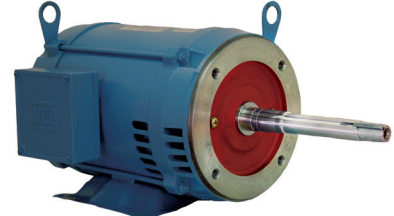

JP

HIGHLIGHTS

- VFD Capable
- Cast Iron Flange

APPLICATIONS

Specially developed line for industrial and commercial pumping applications.

- Water pumping
- Process
- Transfer and circulating pumps

OPTIONAL FEATURES

- Cable glands
- Special Voltages
- Cast iron NEMA C-flange or D-flange (D-flange only for frames 254T and up)
- Special designed shaft
- Second shaft end
- Thermistors, Thermostats or RTD's (PT100)
- Roller bearing on drive end
- IEC metric frames (on request) for frame 254T up to 445T
- Stainless steel shaft
- Class H insulation
- Design C
- 575V

STANDARD FEATURES

- 3 phase, 2, 4 and 6 pole, 60Hz
- Voltage: 208-230/460V, 460V
- Squirrel cage rotor / Aluminum die cast
- Open drip proof design
- NEMA dimensions
- Service factor: 1.15
- Class 'F' insulation
- Temperature rise: Class 'B' (80°C)
- Continuous Duty (S1)
- 104°F (40°C) ambient temperature
- 1045 carbon steel shaft
- F1 mount (with cast iron 'C' Flange)
- Paint: Enamel alkyd resin base
- Color: RAL 5009 (Blue)
- NPT threaded holes in T-Box
- Stainless steel nameplate

ALL MOTORS ARE TESTED ACCORDING TO IEEE 112 STD. - METHOD 'B' OR C390 CSA



E 104590

LR 38324

FRAME – SPECIFIC FEATURES

FOR FRAME 143/5JM/JP, ONLY

- Welded steel plate frames (welded feet)
- Cast iron endshields fixed with through bolt construction
- 'ZZ' bearings (double shielded)
- Degree of protection: IP21

FOR FRAME 182JM up to 215JM

- Welded steel plate frames (welded feet)
- Aluminum endshields and Terminal box
- Cooling system with finned rotor

- Cast iron endshields fixed with through bolt construction
- "ZZ" bearings (double shielded)
- Degree of protection: IP21

FOR FRAME 254JM UP TO 445JM

- Cast iron frames
- Cast iron endshields and terminal box
- Cooling system with finned rotor
- Regreasable bearings system (frame 254JM and up)
- Degree of protection: IP23

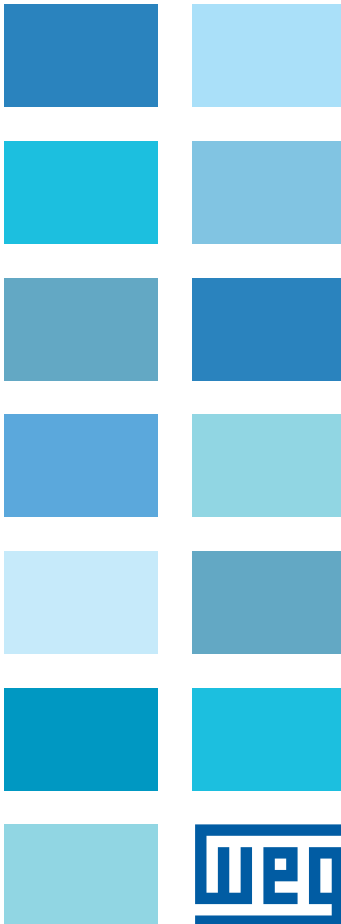

PUMP MOTORS

CLOSE COUPLED PUMP MOTORS

ODP – NEMA PREMIUM



“JM” TYPE – ODP – THREE-PHASE - NEMA PREMIUM

HP	RPM	NEMA Frame	Catalog Number	List Price	Mult. Sym.	Approx. Shipp. Weight Lbs	FL Amps at High Voltage	FL Eff. %	“C” Dimension (in.)	Voltage	Notes
1	1800	143JM	001180T3E143JM	486	P1C	37	1.45	85.5	14.055	208-230/460	
	1200	145JM	001120T3E145JM	550	P1C	37	1.63	82.5	14.055	208-230/460	
1.5	3600	143JM	001560T3E143JM	534	P1C	40	1.90	85.5	14.055	208-230/460	
	1800	145JM	001580T3E145JM	553	P1C	44	2.20	86.5	14.055	208-230/460	
2	1200	182JM	001520T3E182JM	769	P1C	44	2.31	86.5	14.527	208-230/460	
	3600	145JM	002360T3E145JM	580	P1C	42	2.50	86.5	14.055	208-230/460	
3	1800	145JM	002180T3E145JM	607	P1C	44	2.90	86.5	14.055	208-230/460	
	1200	184JM	002120T3E184JM	816	P1C	60	3.03	87.5	15.315	208-230/460	
5	3600	145JM	003360T3E145JM	660	P1C	46	3.50	86.5	14.843	208-230/460	
	1800	182JM	003180T3E182JM	665	P1C	46	4.06	89.5	14.527	208-230/460	
7.5	1200	213JM	003120T3E213JM	1,105	P1C	66	4.27	88.5	17.323	208-230/460	
	3600	182JM	005360T3E182JM	780	P1C	48	6.17	88.5	14.527	208-230/460	
10	1800	184JM	005180T3E184JM	849	P1C	62	6.41	89.5	15.315	208-230/460	
	1200	215JM	005120T3E215JM	1,319	P1C	96	6.92	89.5	17.323	208-230/460	
15	3600	184JM	007360T3E184JM	1,086	P1C	60	8.97	88.5	15.315	208-230/460	
	1800	213JM	007180T3E213JM	1,119	P1C	77	9.03	91.0	17.323	208-230/460	
20	1200	254JM	007120T3E254JM	1,985	P1C	231	9.69	90.2	22.169	208-230/460	
	3600	213JM	010360T3E213JM	1,289	P1C	121	11.9	90.2	17.323	208-230/460	
25	1800	215JM	010180T3E215JM	1,364	P1C	99	12.2	91.7	17.323	208-230/460	
	1200	256JM	010120T3E256JM	2,298	P1C	251	13.0	91.7	23.902	208-230/460	
30	3600	215JM	015360T3E215JM	1,707	P1C	126	17.4	91.0	17.323	208-230/460	
	1800	254JM	015180T3E254JM	1,995	P1C	254	18.6	93.0	22.169	208-230/460	
40	1200	284JM	015120T3E284JM	3,164	P1C	364	17.7	91.7	24.261	208-230/460	
	3600	254JM	020360T3E254JM	2,107	P1C	179	24.6	91.0	22.169	208-230/460	
50	1800	256JM	020180T3E256JM	2,413	P1C	295	25.0	93.0	23.902	208-230/460	
	1200	286JM	020120T3E286JM	3,872	P1C	397	24.0	92.4	25.754	208-230/460	
60	3600	256JM	025360T3E256JM	2,598	P1C	243	29.8	91.7	23.902	208-230/460	
	1800	284JM	025180T3E284JM	2,912	P1C	342	29.9	93.6	24.261	208-230/460	
75	1200	324JM	025120T3E324JM	4,306	P1C	463	30.4	93.0	26.431	208-230/460	
	3600	284JM	030360T3E284JM	3,185	P1C	333	35.2	92.4	24.261	208-230/460	
100	1800	286JM	030180T3E286JM	3,368	P1C	419	35.4	94.1	25.754	208-230/460	
	1200	326JM	030120T3E326JM	4,741	P1C	573	36.0	93.6	27.927	208-230/460	
125	3600	286JM	040360T3E286JM	3,811	P1C	417	47.1	93.0	25.754	208-230/460	
	1800	324JM	040180T3E324JM	3,797	P1C	507	48.2	94.1	26.431	208-230/460	
150	1200	364JM	040120T3E364JM	6,696	P1C	739	48.2	94.1	29.139	208-230/460	
	3600	324JM	050360T3E324JM	4,607	P1C	496	59.1	93.6	26.431	208-230/460	
200	1800	324JM	050360T3G324JM	4,607	P1C	496	59.1	93.6	26.431	460	
	1200	326JM	050180T3E326JM	4,877	P1C	573	61.4	94.5	27.927	208-230/460	
250	3600	365JM	050120T3E365JM	7,666	P1C	862	60.2	94.1	29.139	208-230/460	
	1800	326JM	060360T3E326JM	5,432	P1C	582	71.0	93.6	27.927	208-230/460	
300	3600	364JM	060180T3E364JM	5,994	P1C	825	69.9	95.0	29.139	208-230/460	
	1800	364JM	060180T3G364JM	5,994	P1C	825	69.9	95.0	29.139	460	
350	3600	364JM	075360T3E364JM	6,951	P1C	694	81.5	94.1	29.139	208-230/460	
	1800	364JM	075360T3G364JM	6,951	P1C	694	81.5	94.1	29.139	460	
400	3600	365JM	075180T3E365JM	6,932	P1C	825	85.5	95.0	29.139	208-230/460	
	1800	365JM	075180T3G365JM	6,932	P1C	825	85.5	95.0	29.139	460	
500	3600	365JM	100360T3E365JM	8,683	P1C	825	111	94.5	29.139	208-230/460	
	1800	365JM	100360T3G365JM	8,683	P1C	825	111	94.5	29.139	460	

- ELECTRICAL FEATURES ON PAGE B-16.
- MECHANICAL FEATURES ON PAGE B-81, B-82.

PUMP MOTORS

“JP” TYPE – ODP – THREE-PHASE - NEMA PREMIUM

HP	RPM	NEMA Frame	Catalog Number	List Price	Mult. Sym.	Approx. Shipp. Weight Lbs	FL Amps 460V	FL Eff. %	“C” Dimension (in.)	Voltage	Notes
1	1800	143JP	001180T3E143JP	486	P1C	37	1.45	85.5	17.126	208-230/460	
	1200	145JP	001120T3E145JP	550	P1C	37	1.63	82.5	17.126	208-230/460	
1.5	3600	143JP	001560T3E143JP	534	P1C	40	1.90	85.5	17.126	208-230/460	
	1800	145JP	001580T3E145JP	553	P1C	44	2.20	86.5	17.126	208-230/460	
	1200	182JP	001520T3E182JP	729	P1C	44	2.31	86.5	20.236	208-230/460	
2	3600	145JP	002360T3E145JP	580	P1C	42	2.50	86.5	17.126	208-230/460	
	1800	145JP	002180T3E145JP	607	P1C	44	2.90	86.5	17.126	208-230/460	
	1200	184JP	002120T3E184JP	863	P1C	60	3.03	87.5	21.023	208-230/460	
3	3600	145JP	003360T3E145JP	660	P1C	46	3.50	86.5	17.913	208-230/460	
	1800	182JP	003180T3E182JP	665	P1C	46	4.06	89.5	20.236	208-230/460	
	1200	213JP	003120T3E213JP	1,095	P1C	66	4.27	88.5	21.240	208-230/460	
5	3600	182JP	005360T3E182JP	792	P1C	48	6.17	88.5	20.236	208-230/460	
	1800	184JP	005180T3E184JP	848	P1C	62	6.41	89.5	21.023	208-230/460	
	1200	215JP	005120T3E215JP	1,321	P1C	96	6.92	89.5	21.240	208-230/460	
7.5	3600	184JP	007360T3E184JP	1,086	P1C	60	8.97	88.5	21.023	208-230/460	
	1800	213JP	007180T3E213JP	1,120	P1C	77	9.03	91.0	21.240	208-230/461	
	1200	254JP	007120T3E254JP	2,113	P1C	231	9.69	90.2	25.049	208-230/462	
10	3600	213JP	010360T3E213JP	1,289	P1C	121	11.9	90.2	21.240	208-230/463	
	1800	215JP	010180T3E215JP	1,366	P1C	99	12.2	91.7	21.240	208-230/464	
	1200	256JP	010120T3E256JP	2,298	P1C	251	13.0	91.7	26.782	208-230/465	
15	3600	215JP	015360T3E215JP	1,707	P1C	126	17.4	91.0	21.240	208-230/466	
	1800	254JP	015180T3E254JP	1,995	P1C	254	18.6	93.0	25.049	208-230/460	
	1200	284JP	015120T3E284JP	3,163	P1C	364	17.7	91.7	27.141	208-230/460	
20	3600	254JP	020360T3E254JP	2,106	P1C	179	24.6	91.0	25.049	208-230/460	
	1800	256JP	020180T3E256JP	2,413	P1C	295	25.0	93.0	26.782	208-230/460	
	1200	286JP	020120T3E286JP	3,871	P1C	397	24.0	92.4	28.634	208-230/460	
25	3600	256JP	025360T3E256JP	2,599	P1C	243	29.8	91.7	26.782	208-230/460	
	1800	284JP	025180T3E284JP	2,911	P1C	342	29.9	93.6	27.141	208-230/460	
	1200	324JP	025120T3E324JP	4,306	P1C	463	30.4	93.0	29.311	208-230/460	
30	3600	284JP	030360T3E284JP	3,185	P1C	333	35.2	92.4	27.141	208-230/460	
	1800	286JP	030180T3E286JP	3,367	P1C	419	35.4	94.1	28.634	208-230/461	
	1200	326JP	030120T3E326JP	4,980	P1C	573	36.0	93.6	30.807	208-230/462	
40	3600	286JP	040360T3E286JP	3,811	P1C	417	47.1	93.0	28.634	208-230/463	
	1800	324JP	040180T3E324JP	3,797	P1C	507	48.2	94.1	29.311	208-230/464	
	1200	364JP	040120T3E364JP	7,444	P1C	739	48.2	94.1	32.019	208-230/460	
50	3600	324JP	050360T3E324JP	4,607	P1C	496	59.1	93.6	29.311	208-230/460	
	3600	324JP	050360T3G324JP	4,607	P1C	496	59.1	93.6	29.311	460	
	1800	326JP	050180T3E326JP	4,878	P1C	573	61.4	94.5	30.807	208-230/460	
60	1200	365JP	050120T3E365JP	7,666	P1C	862	60.2	94.1	32.019	208-230/460	
	3600	326JP	060360T3E326JP	5,432	P1C	582	71.0	93.6	30.807	208-230/460	
	1800	364JP	060180T3E364JP	5,994	P1C	825	69.9	95.0	32.019	208-230/460	
	1800	364JP	060180T3G364JP	5,994	P1C	825	69.9	95.0	32.019	460	
75	1200	404JP	060120T3E404JP	9,462	P1C	915	71.2	94.5	35.263	208-230/460	
	3600	364JP	075360T3E364JP	7,699	P1C	694	81.5	94.1	32.019	208-230/460	
	3600	364JP	075360T3G364JP	7,699	P1C	694	81.5	94.1	32.019	460	
	1800	365JP	075180T3E365JP	6,932	P1C	825	85.5	95.0	32.019	208-230/460	
	1800	365JP	075180T3G365JP	6,932	P1C	825	85.5	95.0	32.019	460	
100	1200	405JP	075120T3E405JP	9,762	P1C	1,080	85.9	94.5	35.263	208-230/460	
	3600	365JP	100360T3E365JP	8,544	P1C	825	111	94.5	32.019	208-230/460	
	3600	365JP	100360T3G365JP	8,544	P1C	825	111	94.5	32.019	460	
	1800	404JP	100180T3E404JP	8,545	P1C	1,052	115	95.4	35.263	208-230/460	
1800	404JP	100180T3G404JP	8,545	P1C	1,052	115	95.4	35.263	460		

- ELECTRICAL FEATURES ON PAGE B-16.
- MECHANICAL FEATURES ON PAGE B-81, B-82.



TEFC – THREE PHASE

WEG offers both JM and JP standardized types of close-coupled pump line of motors. Totally enclosed enclosures permit these motors to operate in moist or dusty atmospheres.

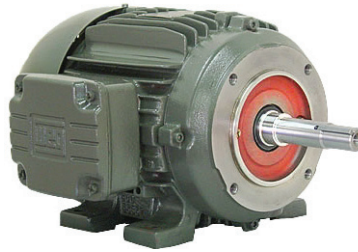

JM

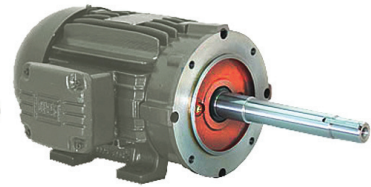

JP

HIGHLIGHTS

- VFD Capable
- Cast Iron Flange

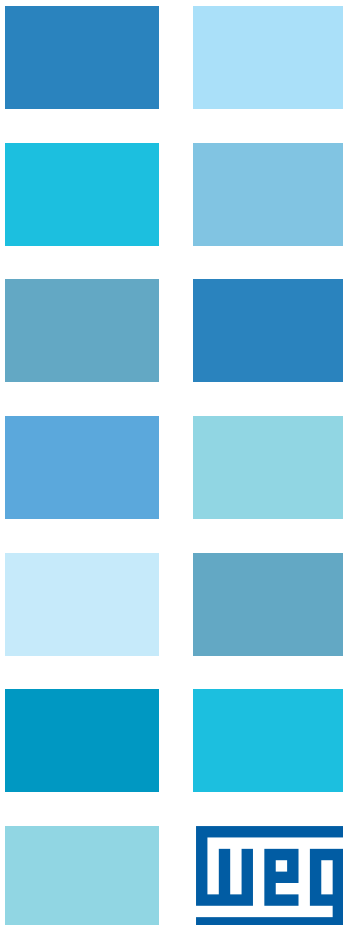

STANDARD FEATURES

- 3 phase, 2, 4, 6 and 8 pole, 60Hz
- Voltage: 208-230/460, 460V
- 2:1 Constant torque
10:1 Variable torque
- Cast iron frames
- Squirrel cage rotor / Aluminum die cast
- Totally Enclosed Fan Cooled
- TEFC (IP55)
- V-ring slingers on both endshields
- Ball bearings
- Service Factor: 1.15
- Class 'F' insulation
- Temperature rise: Class 'B' (80°C)
- Continuous Duty (S1)
- 104°F (40°C) ambient temperature
- Altitude: 3300 ft (1000m)
- 1045 carbon steel shaft
- F1 mount
- Stainless steel nameplate
- Paint: Enamel alkyd resin base
- Color: RAL 7022 (Dark Gray)
- NPT threaded terminal box
- Automatic drain plugs
- Regreasable bearings system (frames
254JM/JP frames and up)

OPTIONAL FEATURES

- Cable glands
- Special voltages
- Specially designed shaft
- Space heaters
- Second shaft end
- Thermistor, Thermostats or RTD's
(PT100)
- Additional terminal box
- Stainless steel shaft
- 575V

APPLICATIONS

Specially developed line for industrial and commercial pumping applications.

- Water pumping
- Process
- Transfer and circulating pumps

WEG also can provide IEC metric frame, cast iron, TEFC. Please ask for specific catalog.

All motors are tested according to IEEE 112 std. - method 'B' or C390 CSA.



PUMP MOTORS



“JM” TYPE – TEFC– THREE-PHASE

HP	RPM	NEMA Frame	Catalog Number	List Price	Multi. Sym.	Approx. Shipp. Weight Lbs.	FL Amps 460	FL Eff %	“C” Dimension (in.)	Voltage	NOTES
1	1800	143JM	00118ES3E143JM	411	P1	40	1.51	78.0	14.304	208-230/460V	
	3600	143JM	00156ES3E143JM	434	P1	40	2.04	78.0	14.304	208-230/460V	
1.5	1800	145JM	00158ES3E145JM	449	P1	40	2.19	79.0	15.304	208-230/460V	
	3600	145JM	00236ES3E145JM	467	P1	44	2.73	78.5	15.304	208-230/460V	
2	1800	145JM	00218ES3E145JM	470	P1	52	2.93	82.5	15.304	208-230/460V	
	3600	145JM	00336ES3E145JM	533	P1	49	4.04	81.5	15.304	208-230/460V	♣
3	3600	W182JM	00336ES3E182JM	578	P1	88	4.04	81.5	15.996	208-230/460V	
	1800	W182JM	00318ES3E182JM	583	P1	73	4.13	81.5	15.996	208-230/460V	
	3600	182JM	00536ES3E182JM	681	P1	93	6.15	84.5	15.996	208-230/460V	♣
5	3600	W184JM	00536ES3E184JM	810	P1	97	6.15	84.5	17.020	208-230/460V	
	1800	182JM	00518ES3E182JM	694	P1	106	6.50	85.0	15.996	208-230/460V	♣
	1800	W184JM	00518ES3E184JM	756	P1	106	6.50	85.0	17.020	208-230/460V	
7.5	3600	184JM	00736ES3E184JM	851	P1	99	9.15	86.7	17.020	208-230/460V	♣
	3600	213JM	00736ES3E213JM	935	P1	145	8.95	86.5	18.678	208-230/460V	
	1800	213JM	00718ES3E213JM	959	P1	152	9.70	87.0	18.678	208-230/460V	
10	3600	213JM	01036ES3E213JM	1,093	P1	154	12.2	87.6	18.678	208-230/460V	♣
	3600	215JM	01036ES3E215JM	1,114	P1	156	12.2	87.6	20.174	208-230/460V	
	1800	213JM	01018ES3E213JM	1,094	P1	150	12.8	89.0	18.678	208-230/460V	♣
	1800	215JM	01018ES3E215JM	1,170	P1	150	12.8	89.0	20.174	208-230/460V	
15	3600	215JM	01536ES3E215JM	1,372	P1	172	17.7	87.8	20.174	208-230/460V	♣
	3600	254JM	01536ES3E254JM	1,570	P1	260	18.2	87.5	24.370	208-230/460V	
	1800	254JM	01518ES3E254JM	1,642	P1	233	18.8	88.5	24.370	208-230/460V	
20	3600	254JM	02036ES3E254JM	1,705	P1	255	24.1	89.0	24.370	208-230/460V	♣
	3600	256JM	02036ES3E256JM	1,926	P1	269	24.1	89.0	26.102	208-230/460V	
	1800	256JM	02018ES3E256JM	1,980	P1	277	25.2	90.2	26.102	208-230/460V	
25	3600	256JM	02536ES3E256JM	2,105	P1	271	29.5	89.5	26.102	208-230/460V	♣
	3600	284JM	02536ES3E284JM	2,378	P1	346	29.7	89.0	27.165	208-230/460V	
	1800	284JM	02518ES3E284JM	2,456	P1	371	30.2	90.5	27.165	208-230/460V	
30	3600	284JM	03036ES3E284JM	2,565	P1	395	35.1	89.5	27.165	208-230/460V	♣
	3600	286JM	03036ES3E286JM	2,730	P1	399	35.1	89.5	28.700	208-230/460V	
	1800	286JM	03018ES3E286JM	2,765	P1	393	36.1	91.0	28.700	208-230/460V	
40	3600	286JM	04036ES3E286JM	3,061	P1	404	48.6	90.2	28.700	208-230/460V	♣
	3600	324JM	04036ES3E324JM	3,734	P1	515	47.4	90.4	28.149	208-230/460V	
	1800	324JM	04018ES3E324JM	3,342	P1	506	48.3	91.7	28.149	208-230/460V	
50	3600	324JM	05036ES3E324JM	3,917	P1	563	57.0	92.2	28.149	208-230/460V	♣
	3600	326JM	05036ES3E326JM	4,348	P1	574	57.0	92.2	29.645	208-230/460V	
	1800	326JM	05018ES3E326JM	3,878	P1	557	58.5	92.4	29.645	208-230/460V	
60	3600	326JM	06036ES3E326JM	4,565	P1	640	70.5	92.0	29.645	208-230/460V	♣
	3600	364JM	06036ES3E364JM	5,461	P1	948	68.5	91.7	33.031	208-230/460V	
	1800	326JM	06018ES3E326JM	4,943	P1	640	72.0	92.5	29.645	208-230/460V	♣
	1800	364JM	06018ES3E364JM	6,695	P1	948	70.0	93.0	33.031	208-230/460V	
75	3600	364JM	07536ES3E364JM	6,960	P1	1058	83.0	92.4	33.031	208-230/460V	♣
	3600	365JM	07536ES3E365JM	8,318	P1	1058	83.0	92.4	33.031	208-230/460V	
	1800	365JM	07518ES3E365JM	7,076	P1	1025	84.5	93.0	33.031	208-230/460V	

• ELECTRICAL FEATURES ON PAGE B-33. • MECHANICAL FEATURES ON PAGE B-84, B-85.

♣ = Reduced Frame ◆ = Product may not be available from stock

PUMP MOTORS

CLOSE COUPLED PUMP MOTORS

STANDARD EFFICIENCY

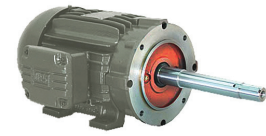

“JP” TYPE – TEFC – THREE-PHASE

HP	RPM	NEMA Frame	Catalog Number	List Price	Multi. Sym.	Approx. Shipp. Weight Lbs.	FL Amps 460	FL Eff %	“C” Dimension (in.)	Voltage	NOTES
1	1800	143JP	00118ES3E143JP	411	P1	40	1.51	78.0	17.365	208-230/460V	
	3600	143JP	00156ES3E143JP	434	P1	40	2.04	78.0	17.365	208-230/460V	
	3600	143JP	00156ES3V143JP	434	P1	40	2.04	78.0	17.365	200/400V	
	1800	145JP	00158ES3E145JP	449	P1	40	2.19	79.0	18.365	208-230/460V	
2	3600	145JP	00236ES3E145JP	467	P1	44	2.73	78.5	18.365	208-230/460V	
	3600	145JP	00236ES3V145JP	467	P1	44	2.73	78.5	18.365	200/400V	
	1800	145JP	00218ES3E145JP	470	P1	52	2.93	82.5	18.365	208-230/460V	
3	3600	145JP	00336ES3E145JP	522	P1	49	4.04	81.5	18.365	208-230/460V	♣
	3600	W182JP	00336ES3E182JP	663	P1	88	4.04	81.5	19.057	208-230/460V	
	3600	182JP	00336ES3V182JP	663	P1	88	4.04	81.5	19.057	200/400V	
	1800	W182JP	00318ES3E182JP	594	P1	73	4.13	81.5	19.057	208-230/460V	
5	3600	182JP	00536ES3E182JP	681	P1	93	6.15	84.5	19.057	208-230/460V	♣
	3600	W184JP	00536ES3E184JP	810	P1	97	6.15	84.5	20.395	208-230/460V	
	3600	184JP	00536ES3V184JP	810	P1	97	6.15	84.5	20.395	200/400V	
	1800	182JP	00518ES3E182JP	708	P1	106	6.50	85.0	19.057	208-230/460V	♣
	1800	W184JP	00518ES3E184JP	770	P1	106	6.50	85.0	20.395	208-230/460V	
7.5	3600	184JP	00736ES3E184JP	851	P1	99	9.15	86.7	20.395	208-230/460V	♣
	3600	213JP	00736ES3E213JP	1,038	P1	145	8.95	86.5	22.550	208-230/460V	
	3600	213JP	00736ES3V213JP	1,038	P1	145	8.95	86.5	22.550	200/400V	
	1800	213JP	00718ES3E213JP	977	P1	152	9.70	87.0	22.550	208-230/460V	
10	3600	213JP	01036ES3E213JP	1,093	P1	154	12.2	87.6	22.550	208-230/460V	♣
	3600	215JP	01036ES3E215JP	1,114	P1	156	12.2	87.6	24.046	208-230/460V	
	3600	215JP	01036ES3V215JP	1,114	P1	156	12.2	87.6	24.046	200/400V	
	1800	213JP	01018ES3E213JP	1,043	P1	150	12.8	89.0	22.550	208-230/460V	♣
	1800	215JP	01018ES3E215JP	1,124	P1	150	12.8	89.0	24.046	208-230/460V	
15	3600	215JP	01536ES3E215JP	1,372	P1	172	17.7	87.8	24.046	208-230/460V	♣
	3600	254JP	01536ES3E254JP	1,598	P1	260	18.2	87.5	26.964	208-230/460V	
	3600	254JP	01536ES3V254JP	1,598	P1	260	18.2	87.5	26.964	200/400V	
	1800	254JP	01518ES3E254JP	1,642	P1	233	18.8	88.5	26.964	208-230/460V	
20	3600	254JP	02036ES3E254JP	1,705	P1	255	24.1	89.0	26.964	208-230/460V	♣
	3600	256JP	02036ES3E256JP	1,781	P1	269	24.1	89.0	28.736	208-230/460V	
	3600	256JP	02036ES3V256JP	1,781	P1	269	24.1	89.0	28.736	200/400V	
	1800	256JP	02018ES3E256JP	1,980	P1	277	25.2	90.2	28.736	208-230/460V	
25	3600	256JP	02536ES3E256JP	2,105	P1	271	29.5	89.5	28.736	208-230/460V	♣
	3600	284JP	02536ES3E284JP	2,443	P1	346	29.7	89.0	30.079	208-230/460V	
	3600	284JP	02536ES3V284JP	2,443	P1	346	29.7	89.0	30.079	200/400V	
	1800	284JP	02518ES3E284JP	2,505	P1	371	30.2	90.5	30.079	208-230/460V	
30	3600	284JP	03036ES3E284JP	2,573	P1	395	35.1	89.5	30.079	208-230/460V	♣
	3600	286JP	03036ES3E286JP	2,716	P1	399	35.1	89.5	31.575	208-230/460V	
	3600	286JP	03036ES3V286JP	2,716	P1	399	35.1	89.5	31.575	200/400V	
	1800	286JP	03018ES3E286JP	2,765	P1	393	36.1	91.0	31.575	208-230/460V	
40	3600	286JP	04036ES3E286JP	3,243	P1	404	48.6	90.2	31.575	208-230/460V	♣
	3600	324JP	04036ES3E324JP	3,513	P1	515	47.4	90.4	32.525	208-230/460V	
	3600	324JP	04036ES3V324JP	3,513	P1	515	47.4	90.4	32.525	200/400V	
	1800	324JP	04018ES3E324JP	3,513	P1	506	48.3	91.7	32.525	208-230/460V	

• ELECTRICAL FEATURES ON PAGE B-33. • MECHANICAL FEATURES ON PAGE B-84, B-85.

♣ = Reduced Frame ◆ = Product may not be available from stock

PUMP MOTORS

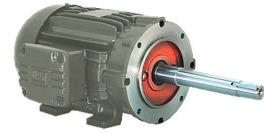

“JP” TYPE – TEFC – THREE-PHASE

HP	RPM	NEMA Frame	Catalog Number	List Price	Multi. Sym.	Approx. Shipp. Weight Lbs.	FL Amps 460	FL Eff %	“C” Dimension (in.)	Voltage	NOTES
50	3600	324JP	05036ES3E324JP	3,917	P1	563	57.0	92.2	32.525	208-230/460V	B ♣
	3600	326JP	05036ES3E326JP	4,229	P1	574	57.0	92.2	34.021	208-230/460V	
	3600	326JP	05036ES3V326JP	4,229	P1	574	57.0	92.2	34.021	200/400V	
	1800	326JP	05018ES3E326JP	4,095	P1	557	58.5	92.4	34.021	208-230/460V	
60	3600	326JP	06036ES3E326JP	5,334	P1	640	70.5	92.0	34.021	208-230/460V	B ♣
	3600	364JP	06036ES3E364JP	6,025	P1	948	68.5	91.7	35.916	208-230/460V	
	3600	364JP	06036ES3V364JP	6,025	P1	948	68.5	91.7	35.916	200/400V	
	1800	326JP	06018ES3E326JP	5,621	P1	640	72.0	92.5	34.021	208-230/460V	B ♣
	1800	364JP	06018ES3E364JP	6,829	P1	948	70.0	93.0	35.916	208-230/460V	
75	3600	364JP	07536ES3E364JP	7,191	P1	1058	83.0	92.4	35.916	208-230/460V	B ♣
	3600	365JP	07536ES3E365JP	8,483	P1	1058	83.0	92.4	35.916	208-230/460V	
	3600	365JP	07536ES3V365JP	8,483	P1	1058	83.0	92.4	35.916	200/400V	
	1800	365JP	07518ES3E365JP	7,218	P1	1025	84.5	93.0	35.916	208-230/460V	
100	3600	404JP	10036ES3E404JP	8,588	P1	1180	111	93.0	38.911	208-230/460V	B ♣
	3600	404JP	10036ES3G404JP	8,588	P1	1180	111	93.0	38.911	460V	B ♣
	1800	405JP	10018ES3E405JP	8,589	P1	1302	116	93.2	38.911	208-230/460V	
	1800	405JP	10018ES3G405JP	8,589	P1	1302	116	93.2	38.911	460V	

- ELECTRICAL FEATURES ON PAGE B-33.
- MECHANICAL FEATURES ON PAGE B-84, B-85.

♣ = Reduced Frame

TEFC – THREE PHASE

WEG offers both JM and JP standardized types of close-coupled pump line of motors. Totally enclosed enclosures permit these motors to operate in moist or dusty atmospheres.

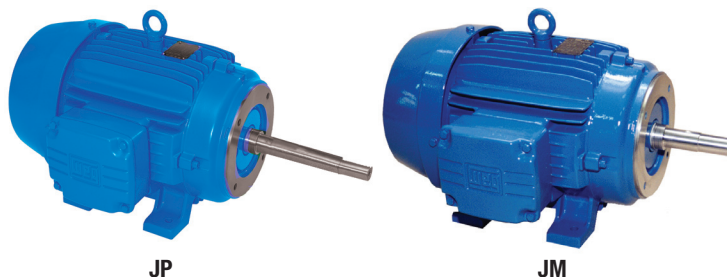

HIGHLIGHTS

- VFD Capable
- Cast Iron Flange

APPLICATIONS

Specially developed line for industrial and commercial pumping applications.

- Water pumping
- Process
- Transfer and circulating pumps

STANDARD FEATURES

- 3 phase, 2, 4, 6 and 8 pole, 60Hz
- Voltage: 208-230/460, 460V
- 12:1 Constant torque
100:1 Variable torque
- Cast iron frames
- Squirrel cage rotor / Aluminum die cast
- Totally Enclosed Fan Cooled - TEFC
- V-ring slingers on both endshields
- Ball bearings
- Service Factor: 1.25
- Class 'F' insulation
- Temperature rise: Class 'B' (80°C)
- Continuous Duty (S1)
- 104°F (40°C) ambient temperature
- Altitude: 3300 ft (1000m)
- 1045 carbon steel shaft
- F1 mount
- Stainless steel nameplate
- Paint: Enamel alkyd resin base
- Color: RAL 5009 – Blue
- NPT threaded terminal box
- Automatic drain plugs
- Regreasable bearings system (frames 254JM/JP frames and up)



OPTIONAL FEATURES

- Cable glands
- Special voltages
- Specially designed shaft
- Space heaters
- Second shaft end
- Thermistor, Thermostats or RTD's (PT100)
- Additional terminal box
- Stainless steel shaft
- 575V

* Design B torque rating on nameplate can be re-plated for Design C for 15-200Hp 1800 and 1200 rpm.





“JM” TYPE – TEFC – THREE-PHASE

HP	RPM	NEMA Frame	Catalog Number	List Price	Multi. Sym.	Approx. Shipp. Weight Lbs.	FL Amps 460	FL Eff %	“C” Dimension (in.)	Voltage	NOTES
1	1800	143JM	00118EP3E143JM	497	P1	47	1.49	82.5	14.304	208-230/460V	
1.5	3600	143JM	00156EP3E143JM	527	P1	45	1.99	82.5	14.304	208-230/460V	
	1800	145JM	00158EP3E145JM	509	P1	54	2.05	84.0	15.304	208-230/460V	
2	3600	145JM	00236EP3E145JM	583	P1	47	2.60	84.0	15.304	208-230/460V	
	1800	145JM	00218EP3E145JM	560	P1	56	2.70	84.0	15.304	208-230/460V	
3	3600	145JM	00336EP3E145JM	647	P1	54	3.71	85.5	15.304	208-230/460V	♣
	3600	182JM	00336EP3E182JM	744	P1	106	3.59	85.5	15.996	208-230/460V	
	1800	182JM	00318EP3E182JM	886	P1	97	3.90	87.5	15.996	208-230/460V	
5	3600	184JM	00536EP3E184JM	922	P1	114	5.90	87.5	17.020	208-230/460V	
	1800	184JM	00518EP3E184JM	993	P1	102	6.48	87.5	17.020	208-230/460V	
7.5	3600	184JM	00736EP3E184JM	1,125	P1	128	8.76	88.5	17.020	208-230/460V	♣
	3600	213JM	00736EP3E213JM	1,277	P1	150	8.66	88.5	18.678	208-230/460V	
	1800	213JM	00718EP3E213JM	1,256	P1	150	9.53	89.5	18.678	208-230/460V	
10	3600	215JM	01036EP3E215JM	1,581	P1	150	11.7	89.5	20.174	208-230/460V	
	1800	215JM	01018EP3E215JM	1,502	P1	165	12.8	90.2	20.174	208-230/460V	
15	3600	215JM	01536EP3E215JM	1,803	P1	174	17.3	90.2	20.174	208-230/460V	♣
	3600	254JM	01536EP3E254JM	2,029	P1	280	17.0	90.2	24.370	208-230/460V	
	1800	254JM	01518EP3E254JM	2,256	P1	266	17.9	91.0	24.370	208-230/460V	
20	3600	254JM	02036EP3E254JM	2,368	P1	304	23.3	90.2	24.370	208-230/460V	♣
	3600	256JM	02036EP3E256JM	2,568	P1	313	23.3	90.2	26.102	208-230/460V	
	1800	256JM	02018EP3E256JM	2,490	P1	313	24.4	91.0	26.102	208-230/460V	
25	3600	256JM	02536EP3E256JM	2,803	P1	313	28.4	91.0	26.102	208-230/460V	♣
	3600	284JM	02536EP3E284JM	2,989	P1	353	29.0	91.0	27.165	208-230/460V	
	1800	284JM	02518EP3E284JM	3,186	P1	437	29.6	92.4	27.165	208-230/460V	◆
30	3600	284JM	03036EP3E284JM	3,545	P1	399	33.8	91.0	27.165	208-230/460V	♣
	3600	286JM	03036EP3E286JM	3,797	P1	404	33.8	91.0	28.700	208-230/460V	
	1800	286JM	03018EP3E286JM	3,559	P1	481	34.4	92.4	28.700	208-230/460V	◆
40	3600*	286JM	04036EP3E286JM	4,353	P1	448	46.6	91.7	28.700	208-230/460V	♣
	3600	324JM	04036EP3E324JM	4,746	P1	561	46.1	91.7	28.149	208-230/460V	
	1800	324JM	04018EP3E324JM	4,803	P1	587	47.6	93.0	28.149	208-230/460V	◆
50	3600	324JM	05036EP3E324JM	5,070	P1	565	56.5	92.4	28.149	208-230/460V	♣
	3600	326JM	05036EP3E326JM	5,502	P1	594	56.5	92.4	29.645	208-230/460V	
	1800	326JM	05018EP3E326JM	5,500	P1	640	57.8	93.6	29.645	208-230/460V	◆
60	3600	326JM	06036EP3E326JM	6,598	P1	594	69.0	93.0	29.645	208-230/460V	♣
	3600	364JM	06036EP3E364JM	7,137	P1	917	69.0	93.0	33.031	208-230/460V	
	1800	326JM	06018EP3E326JM	7,349	P1	687	72.7	93.6	29.645	208-230/460V	♣◆
	1800	364JM	06018EP3E364JM	7,805	P1	963	67.0	93.6	33.031	208-230/460V	◆
75	3600	364JM	07536EP3E364JM	8,995	P1	1025	82.5	93.0	33.031	208-230/460V	♣
	1800	365JM	07518EP3E365JM	8,860	P1	1010	82.4	94.1	33.031	208-230/460V	◆

- ELECTRICAL FEATURES ON PAGE B-6, B-7.
- MECHANICAL FEATURES ON PAGE B-84, B-85.

♣ = Reduced Frame
 ◆ = Product may not be available from stock

PUMP MOTORS

CLOSE COUPLED PUMP MOTORS

HIGH EFFICIENCY



“JP” TYPE – TEFC – THREE-PHASE

HP	RPM	NEMA Frame	Catalog Number	List Price	Multi. Sym.	Approx. Shipp. Weight Lbs.	FL Amps 460	FL Eff %	“C” Dimension (in.)	Voltage	NOTES
1	1800	143JP	00118EP3E143JP	508	P1	47	1.49	82.5	17.365	208-230/460V	
1.5	3600	143JP	00156EP3E143JP	537	P1	45	1.99	82.5	17.365	208-230/460V	
	1800	145JP	00158EP3E145JP	519	P1	54	2.05	84.0	18.365	208-230/460V	
2	3600	145JP	00236EP3E145JP	594	P1	47	2.60	84.0	18.365	208-230/460V	
	1800	145JP	00218EP3E145JP	571	P1	56	2.70	84.0	18.365	208-230/460V	
3	3600	145JP	00336EP3E145JP	632	P1	54	3.71	85.5	18.365	208-230/460V	♣
	3600	182JP	00336EP3E182JP	759	P1	106	3.59	85.5	19.057	208-230/460V	
	1800	182JP	00318EP3E182JP	905	P1	97	3.90	87.5	19.057	208-230/460V	
5	3600	184JP	00536EP3E184JP	941	P1	114	5.90	87.5	20.395	208-230/460V	
	1800	184JP	00518EP3E184JP	1,013	P1	102	6.48	87.5	20.395	208-230/460V	
7.5	3600	184JP	00736EP3E184JP	1,146	P1	128	8.76	88.5	20.395	208-230/460V	♣
	3600	213JP	00736EP3E213JP	1,303	P1	150	8.66	88.5	22.550	208-230/460V	
	1800	213JP	00718EP3E213JP	1,280	P1	150	9.53	89.5	22.550	208-230/460V	
10	3600	215JP	01036EP3E215JP	1,613	P1	150	11.7	89.5	24.046	208-230/460V	
	1800	215JP	01018EP3E215JP	1,533	P1	165	12.8	90.2	24.046	208-230/460V	
15	3600	215JP	01536EP3E215JP	1,791	P1	174	17.3	90.2	24.046	208-230/460V	♣
	3600	254JP	01536EP3E254JP	2,069	P1	280	17.0	90.2	26.964	208-230/460V	
	1800	254JP	01518EP3E254JP	2,300	P1	266	17.9	91.0	26.964	208-230/460V	♣
20	3600	254JP	02036EP3E254JP	2,451	P1	304	23.3	90.2	26.964	208-230/460V	♣
	3600	256JP	02036EP3E256JP	2,621	P1	313	23.3	90.2	28.736	208-230/460V	
	1800	256JP	02018EP3E256JP	2,541	P1	313	24.4	91.0	28.736	208-230/460V	◆
25	3600	256JP	02536EP3E256JP	2,790	P1	313	28.4	91.0	28.736	208-230/460V	♣
	3600	284JP	02536EP3E284JP	3,049	P1	353	29.0	91.0	30.079	208-230/460V	
	1800	284JP	02518EP3E284JP	3,249	P1	437	29.6	92.4	30.079	208-230/460V	◆
30	3600	284JP	03036EP3E284JP	3,519	P1	399	33.8	91.0	30.079	208-230/460V	♣
	3600	286JP	03036EP3E286JP	3,872	P1	404	33.8	91.0	31.575	208-230/460V	
	1800	286JP	03018EP3E286JP	3,630	P1	481	34.4	92.4	31.575	208-230/460V	◆
40	3600	286JP	04036EP3E286JP	4,545	P1	448	46.6	91.7	31.575	208-230/460V	♣
	3600	324JP	04036EP3E324JP	4,840	P1	561	46.1	91.7	32.525	208-230/460V	
	1800	324JP	04018EP3E324JP	4,900	P1	587	47.6	93.0	32.525	208-230/460V	◆
50	3600	324JP	05036EP3E324JP	4,954	P1	565	56.5	92.4	32.525	208-230/460V	♣
	3600	326JP	05036EP3E326JP	5,613	P1	594	56.5	92.4	34.021	208-230/460V	
	1800	326JP	05018EP3E326JP	5,611	P1	640	57.8	93.6	34.021	208-230/460V	◆
60	3600	326JP	06036EP3E326JP	7,954	P1	594	69.0	93.0	34.021	208-230/460V	♣
	3600	364JP	06036EP3E364JP	8,412	P1	917	69.0	93.0	35.916	208-230/460V	
	1800	326JP	06018EP3E326JP	7,176	P1	687	72.7	93.6	34.021	208-230/460V	◆ ♣
	1800	364JP	06018EP3E364JP	7,960	P1	963	67.0	93.6	35.916	208-230/460V	◆
75	3600	364JP	07536EP3E364JP	9,623	P1	1025	82.5	93.0	35.916	208-230/460V	♣
	3600	365JP	07536EP3E365JP	10,045	P1	1025	82.5	93.0	35.916	208-230/460V	
	1800	365JP	07518EP3E365JP	9,038	P1	1010	82.4	94.1	35.916	208-230/460V	◆
100	3600	405JP	10036EP3E405JP	11,449	P1	1361	113	93.6	38.911	208-230/460V	
	3600	405JP	10036EP3G405JP	11,449	P1	1361	113	93.6	38.911	460V	
	1800	405JP	10018EP3E405JP	10,269	P1	1273	115	94.5	38.911	208-230/460V	◆
	1800	405JP	10018EP3G405JP	10,269	P1	1273	115	94.5	38.911	460V	◆

• ELECTRICAL FEATURES ON PAGE B-6, B-7. • MECHANICAL FEATURES ON PAGE B-84, B-85.

♣ = Reduced Frame

◆ = Product may not be available from stock

PUMP MOTORS



Pump Motors

Close Coupled - NEMA PREMIUM

TEFC – THREE PHASE

WEG offers both JM and JP standardized types of close-coupled pump line motors. Totally enclosed enclosures permit these motors to operate in moist or dust atmospheres.

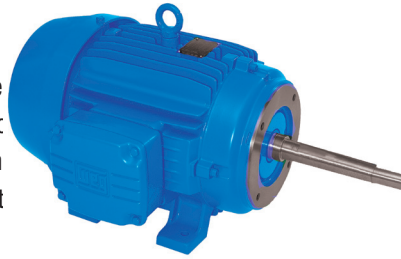

JP

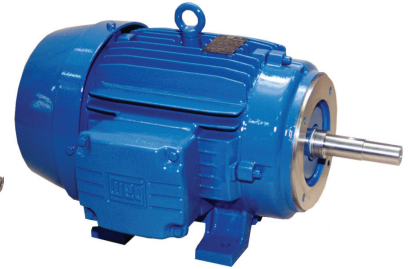

JM

HIGHLIGHTS

- VFD Capable
- Cast Iron Flange

APPLICATIONS

Specially developed line for industrial and commercial pumping applications.

- Water pumping
- Process
- Transfer and circulating pumps

STANDARD FEATURES

- 3 phase, 2, 4, 6 and 8 pole, 60Hz
- Voltage: 208-230/460, 460V
- 20:1 Constant torque
100:1 Variable torque
- Cast iron frames
- Squirrel cage rotor / Aluminum die cast
- Totally Enclosed Fan Cooled - TEFC
- V-ring slingers on both endshields
- Ball bearings
- Service Factor: 1.25
- Class 'F' insulation
- Temperature rise: Class 'B' (80°C)
- Continuous Duty (S1)
- 104°F (40°C) ambient temperature
- Altitude: 3300 ft (1000m)
- 1045 carbon steel shaft
- F1 mount
- Stainless steel nameplate
- Paint: Enamel alkyd resin base
- Color: RAL 5009 – Blue
- NPT threaded terminal box
- Automatic drain plugs
- Regreasable bearings system (frames 254JM/JP frames and up)

OPTIONAL FEATURES

- Cable glands
- Special voltages
- Specially designed shaft
- Space heaters
- Second shaft end
- Thermistor, Thermostats or RTD's (PT100)
- Additional terminal box
- Stainless steel shaft
- 575V



CLOSE COUPLED PUMP MOTORS

NEMA PREMIUM



“JM” TYPE – TEFC – THREE-PHASE - NEMA PREMIUM

HP	RPM	NEMA Frame	Catalog Number	List Price	Mult. Sym.	Approx. Shipp. Weight Lbs	FL Amps 460V	FL Eff. %	“C” Dimension (in.)	Voltage	Notes
1	1800	143JM	00118ET3E143JM	613	P1	51	1.43	85.5	14.304	208-230/460	
	1200	145JM	00112ET3E145JM	700	P1	53	1.73	82.5	15.304	208-230/460	
1.5	3600	143JM	00156ET3E143JM	710	P1	42	1.98	84.0	14.304	208-230/460	
	1800	145JM	00158ET3E145JM	643	P1	53	2.00	86.5	15.304	208-230/460	
	1200	182JM	00152ET3E182JM	909	P1	70	2.39	87.5	15.996	208-230/460	
2	3600	145JM	00236ET3E145JM	683	P1	49	2.65	85.5	15.304	208-230/460	
	1800	145JM	00218ET3E145JM	707	P1	55	2.63	86.5	15.304	208-230/460	
	1200	184JM	00212ET3E184JM	1,021	P1	88	3.23	88.5	17.020	208-230/460	
3	3600	182JM	00336ET3E182JM	918	P1	90	3.68	87.5	15.996	208-230/460	
	1800	182JM	00318ET3E182JM	1,022	P1	90	3.90	89.5	15.996	208-230/460	
	1200	213JM	00312ET3E213JM	1,423	P1	121	4.41	89.5	18.678	208-230/460	
5	3600	184JM	00536ET3E184JM	1,075	P1	105	5.96	89.5	17.020	208-230/460	
	1800	184JM	00518ET3E184JM	1,141	P1	99	6.40	89.5	17.020	208-230/460	
	1200	215JM	00512ET3E215JM	1,769	P1	162	6.83	89.5	20.174	208-230/460	
7.5	3600	213JM	00736ET3E213JM	1,419	P1	121	8.63	91.0	18.678	208-230/460	
	1800	213JM	00718ET3E213JM	1,519	P1	152	9.29	91.7	18.678	208-230/460	
	1200	254JM	00712ET3E254JM	2,455	P1	256	9.73	91.0	24.370	208-230/460	
10	3600	215JM	01036ET3E215JM	1,769	P1	160	11.5	91.7	20.174	208-230/460	
	1800	215JM	01018ET3E215JM	1,792	P1	159	12.6	91.7	20.174	208-230/460	
	1200	256JM	01012ET3E256JM	2,979	P1	289	13.3	91.0	26.102	208-230/460	
15	3600	215JM	01536ET3E215JM	2,058	P1	171	17.0	91.0	20.174	208-230/460	
	3600	254JM	01536ET3E254JM	2,214	P1	254	16.9	91.7	24.370	208-230/460	
	1800	254JM	01518ET3E254JM	2,609	P1	265	18.0	92.4	24.370	208-230/460	
	1200	284JM	01512ET3E284JM	3,912	P1	320	17.3	91.7	27.165	208-230/460	
20	3600	256JM	02036ET3E256JM	2,965	P1	287	22.9	92.4	26.102	208-230/460	
	1800	256JM	02018ET3E256JM	2,857	P1	298	24.4	93.0	26.102	208-230/460	
	1200	286JM	02012ET3E286JM	4,940	P1	463	24.1	91.7	28.700	208-230/460	
25	3600	284JM	02536ET3E284JM	3,619	P1	313	28.4	93.0	27.165	208-230/460	
	1800	284JM	02518ET3E284JM	3,734	P1	441	29.5	93.6	27.165	208-230/460	
	1200	324JM	02512ET3E324JM	5,546	P1	560	30.5	93.0	28.149	208-230/460	
30	3600	286JM	03036ET3E286JM	4,539	P1	388	33.4	93.0	28.700	208-230/460	
	1800	286JM	03018ET3E286JM	4,096	P1	485	35.1	93.6	28.700	208-230/460	
	1200	326JM	03012ET3E326JM	6,686	P1	628	35.8	93.0	29.645	208-230/460	
40	3600	324JM	04036ET3E324JM	5,534	P1	516	45.8	93.6	28.149	208-230/460	
	1800	324JM	04018ET3E324JM	5,316	P1	595	48.3	94.1	28.149	208-230/460	
	1200	364JM	04012ET3E364JM	8,807	P1	966	47.1	94.1	33.031	208-230/460	
50	3600	326JM	05036ET3E326JM	6,622	P1	562	55.5	94.1	29.645	208-230/460	
	1800	326JM	05018ET3E326JM	6,513	P1	617	60.6	94.5	29.645	208-230/460	
	1200	365JM	05012ET3E365JM	10,551	P1	1016	58.0	94.1	33.031	208-230/460	
60	3600	364JM	06036ET3E364JM	8,261	P1	882	68.3	94.1	33.031	208-230/460	
	1800	364JM	06018ET3E364JM	8,912	P1	926	68.4	95.0	33.031	208-230/460	
75	3600	365JM	07536ET3E365JM	11,124	P1	915	80.8	95.0	33.031	208-230/460	
	1800	365JM	07518ET3E365JM	10,057	P1	937	82.3	95.4	33.031	208-230/460	

- ELECTRICAL FEATURES ON PAGE B-14, B-15.
- MECHANICAL FEATURES ON PAGE B-84, B-85.

Can't find what you are looking for? Call 1-800-ASK-4WEG (275-4934)

Data subject to change without notice.



“JP” TYPE – TEFC – THREE-PHASE - NEMA PREMIUM

HP	RPM	NEMA Frame	Catalog Number	List Price	Mult. Sym.	Approx. Shipp. Weight Lbs	FL Amps 460V	FL Eff. %	“C” Dimension (in.)	Voltage	Notes
1	1800	143JP	00118ET3E143JP	624	P1	51	1.43	85.5	17.365	208-230/460	
	1200	145JP	00112ET3E145JP	714	P1	53	1.73	82.5	18.365	208-230/460	
1.5	3600	143JP	00156ET3E143JP	649	P1	42	1.98	84.0	17.365	208-230/460	
	1800	145JP	00158ET3E145JP	653	P1	53	2.00	86.5	18.365	208-230/460	
	1200	182JP	00152ET3E182JP	924	P1	70	2.39	87.5	19.057	208-230/460	
2	3600	145JP	00236ET3E145JP	694	P1	49	2.65	85.5	18.365	208-230/460	
	1800	145JP	00218ET3E145JP	718	P1	55	2.63	86.5	18.365	208-230/460	
	1200	184JP	00212ET3E184JP	1,040	P1	88	3.23	88.5	20.395	208-230/460	
3	3600	182JP	00336ET3E182JP	933	P1	90	3.68	87.5	19.057	208-230/460	
	1800	182JP	00318ET3E182JP	1,041	P1	90	3.90	89.5	19.057	208-230/460	
	1200	213JP	00312ET3E213JP	1,449	P1	121	4.41	89.5	22.55	208-230/460	
5	3600	184JP	00536ET3E184JP	1,094	P1	105	5.96	89.5	20.395	208-230/460	
	1800	184JP	00518ET3E184JP	1,161	P1	99	6.40	89.5	20.395	208-230/460	
	1200	215JP	00512ET3E215JP	1,801	P1	162	6.83	89.5	24.046	208-230/460	
7.5	3600	213JP	00736ET3E213JP	1,445	P1	121	8.63	91.0	22.55	208-230/460	
	1800	213JP	00718ET3E213JP	1,543	P1	152	9.29	91.7	22.55	208-230/460	
	1200	254JP	00712ET3E254JP	2,495	P1	256	9.73	91.0	26.964	208-230/460	
10	3600	215JP	01036ET3E215JP	1,801	P1	160	11.5	91.7	24.046	208-230/460	
	1800	215JP	01018ET3E215JP	1,823	P1	159	12.6	91.7	24.046	208-230/460	
	1200	256JP	01012ET3E256JP	3,103	P1	289	13.3	91.0	28.736	208-230/460	
15	3600	254JP	01536ET3E254JP	2,629	P1	254	16.9	91.7	26.964	208-230/460	
	1800	254JP	01518ET3E254JP	2,653	P1	265	18.0	92.4	26.964	208-230/460	
	1200	284JP	01512ET3E284JP	3,972	P1	320	17.3	91.7	30.079	208-230/460	
20	3600	256JP	02036ET3E256JP	3,018	P1	287	22.9	92.4	28.736	208-230/460	
	1800	256JP	02018ET3E256JP	2,908	P1	298	24.4	93.0	28.736	208-230/460	
	1200	286JP	02012ET3E286JP	5,015	P1	463	24.1	91.7	31.575	208-230/460	
25	3600	284JP	02536ET3E284JP	3,679	P1	313	28.4	93.0	30.079	208-230/460	
	1800	284JP	02518ET3E284JP	3,797	P1	441	29.5	93.6	30.079	208-230/460	
	1200	324JP	02512ET3E324JP	5,972	P1	560	30.5	93.0	32.525	208-230/460	
30	3600	286JP	03036ET3E286JP	4,614	P1	388	33.4	93.0	31.575	208-230/460	
	1800	286JP	03018ET3E286JP	4,167	P1	485	35.1	93.6	31.575	208-230/460	
	1200	326JP	03012ET3E326JP	6,690	P1	628	35.8	93.0	34.021	208-230/460	
40	3600	324JP	04036ET3E324JP	5,628	P1	516	45.8	93.6	32.525	208-230/460	
	1800	324JP	04018ET3E324JP	5,413	P1	595	48.3	94.1	32.525	208-230/460	
	1200	364JP	04012ET3E364JP	9,268	P1	966	47.1	94.1	35.916	208-230/460	
50	3600	326JP	05036ET3E326JP	6,733	P1	562	55.5	94.1	34.021	208-230/460	
	1800	326JP	05018ET3E326JP	6,624	P1	617	60.6	94.5	34.021	208-230/460	
	1200	365JP	05012ET3E365JP	10,748	P1	1016	58.0	94.1	35.916	208-230/460	
60	3600	364JP	06036ET3E364JP	10,252	P1	882	68.3	94.1	35.916	208-230/460	
	1800	364JP	06018ET3E364JP	9,619	P1	926	68.4	95.0	35.916	208-230/460	
	1200	404JP	06012ET3E404JP	12,444	P1	1190	70.4	94.5	38.911	208-230/460	
75	3600	365JP	07536ET3E365JP	11,321	P1	915	80.8	95.0	35.916	208-230/460	
	1800	365JP	07518ET3E365JP	10,235	P1	937	82.3	95.4	35.916	208-230/460	
	1200	405JP	07512ET3E405JP	14,005	P1	1323	87.0	94.5	38.911	208-230/460	
100	3600	405JP	10036ET3E405JP	13,949	P1	1206	110	95.0	38.911	208-230/460	
	3600	405JP	10036ET3G405JP	13,949	P1	1206	110	95.0	38.911	460	
	1800	405JP	10018ET3E405JP	12,411	P1	1146	112	95.4	38.911	208-230/460	
	1800	405JP	10018ET3G405JP	12,411	P1	1146	112	95.4	38.911	460	

• ELECTRICAL FEATURES ON PAGE B-14, B-15.

• MECHANICAL FEATURES ON PAGE B-84, B-85.

Pump Motors P-Base

THREE PHASE

HP and HPH types are available. These motors are suitable for dusty or moist environments and provide high starting torque, with efficient performance.

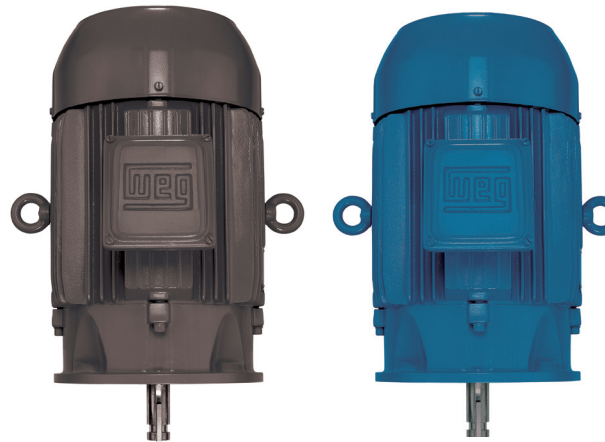

Standard Efficiency

High Efficiency

HIGHLIGHTS

- Ideal for applications with heavy white thrust loads

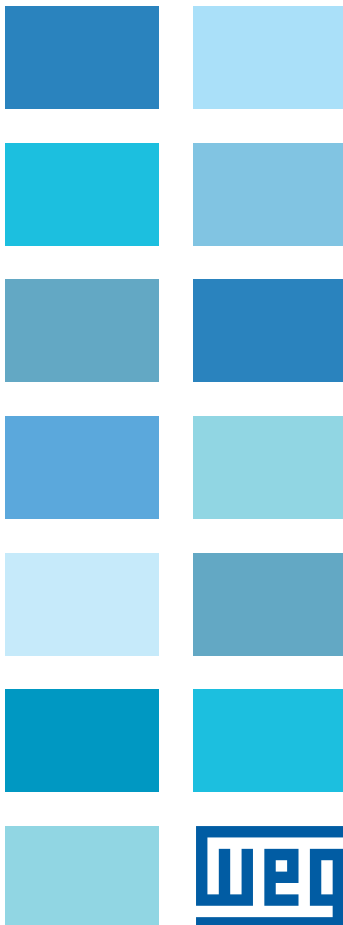

APPLICATIONS

Normal thrust in-line pump applications

- Waste water treatment plants
- Petro chemical industries
- Pulp and paper mills
- Agricultural irrigation

OPTIONAL FEATURES

- Cable glands
- Special voltages
- Space heaters
- Thermistor, Thermostats or RTD's (PT100)
- Additional terminal box
- Stainless steel shaft
- Design C for High Efficiency and NEMA Premium Efficiency
- Insulation class "H"
- 575V
- 6 & 8 pole, 60Hz



NOTE: Motors are tested according to IEEE 112 std. - method 'B' or C390 CSA .
High Efficiency motors are suitable for Inverter Duty.

STANDARD FEATURES

- Three-phase, 2, 4 pole, 60Hz
- Voltage: 208-230/460, 460
- HP type: from frames 143HP up to 445HP
- HPH type: frames 284/6HPH and 404/5HPH
- Squirrel cage rotor / Aluminum die cast
- Totally Enclosed Fan Cooled- TEFC (IP55)
- V-ring slingers on both endshields
- Cast iron frame
- Ball bearings
- Class 'F' insulation for all frames
- Service factor for High Efficiency: 1.25 up to 100HP
1.15 from 125HP and up
- Service Factor for Standard Efficiency: 1.15
- Temperature rise: Class 'B' (80°C)
- Continuous Duty (S1)
- 104°F (40°C) ambient temperature
- Altitude: 3300 ft (1000 m)
- 1045 carbon steel shaft
- Usual mounting: V1 - footless
- Stainless steel nameplate
- Paint: Enamel alkyd resin base
- Color: RAL 7022 - Dark Gray (Standard Efficiency)
- Color: RAL 5009 - Blue (High Efficiency)
- NPT threaded terminal box
- Automatic drain plugs
- Regreasable bearings system (frames 254HP and up)
- Drip cover (canopy)
- Class I, Div 2. Groups A, B, C, D & T3

PUMP MOTORS



HP & HPH TYPE – TEFC STANDARD EFFICIENCY

HP	RPM	NEMA Frame	Catalog Number	List Price	Multi. Sym.	Approx. Shipp. Weight Lbs.	FL Amps 460	FL Eff %	“C” Dimension (in.)	Voltage	NOTES
1	1800	143HP	00118ES3E143HP	375	P1F	40	1.51	78.0	13.421	208-230/460V	
	3600	143HP	00156ES3E143HP	390	P1F	40	2.04	78.0	13.421	208-230/460V	
1.5	1800	145HP	00158ES3E145HP	396	P1F	40	2.19	79.0	14.397	208-230/460V	
	3600	145HP	00236ES3E145HP	405	P1F	44	2.73	78.5	14.397	208-230/460V	
2	1800	145HP	00218ES3E145HP	436	P1F	52	2.93	82.5	14.397	208-230/460V	
	3600	145HP	00336ES3E145HP	548	P1F	49	4.04	81.5	14.397	208-230/460V	♣
3	3600	182HP	00336ES3E182HP	602	P1F	88	4.04	81.5	15.504	208-230/460V	
	1800	182HP	00318ES3E182HP	606	P1F	73	4.13	81.5	15.504	208-230/460V	
	3600	182HP	00536ES3E182HP	604	P1F	93	6.15	84.5	15.504	208-230/460V	♣
5	3600	184HP	00536ES3E184HP	721	P1F	97	6.15	84.5	16.504	208-230/460V	
	1800	182HP	00518ES3E182HP	723	P1F	106	6.50	85.0	15.504	208-230/460V	♣
	1800	184HP	00518ES3E184HP	786	P1F	106	6.50	85.0	16.504	208-230/460V	
	3600	184HP	00736ES3E184HP	908	P1F	99	9.15	86.7	16.504	208-230/460V	♣
7.5	3600	213HP	00736ES3E213HP	972	P1F	145	8.95	86.5	18.630	208-230/460V	
	1800	213HP	00718ES3E213HP	998	P1F	152	9.70	87.0	18.630	208-230/460V	
	3600	213HP	01036ES3E213HP	1,032	P1F	154	12.2	87.6	18.630	208-230/460V	
10	3600	215HP	01036ES3E215HP	1,044	P1F	156	12.2	87.6	20.126	208-230/460V	
	1800	213HP	01018ES3E213HP	1,062	P1F	150	12.8	89.0	18.630	208-230/460V	
	1800	215HP	01018ES3E215HP	1,148	P1F	150	12.8	89.0	20.126	208-230/460V	
15	3600	254HP	01536ES3E254HP	1,311	P1F	172	17.7	87.8	20.126	208-230/460V	♣
	1800	254HP	01518ES3E254HP	1,669	P1F	233	18.8	88.5	23.723	208-230/460V	
	3600	254HP	02036ES3E254HP	1,643	P1F	255	24.1	89.0	23.723	208-230/460V	♣
20	3600	256HP	02036ES3E256HP	1,796	P1F	269	24.1	89.0	25.455	208-230/460V	
	1800	256HP	02018ES3E256HP	1,824	P1F	277	25.2	90.2	25.455	208-230/460V	
	3600	256HP	02536ES3E256HP	2,133	P1F	271	29.5	89.5	25.455	208-230/460V	♣
25	3600	284HP	02536ES3E284HP	2,474	P1F	346	29.7	89.0	26.350	208-230/460V	
	3600	284HPH	02536ES3E284HPH	2,474	P1F	346	29.7	89.0	25.100	208-230/460V	
	1800	284HP	02518ES3E284HP	2,556	P1F	371	30.2	90.5	26.350	208-230/460V	
	1800	284HPH	02518ES3E284HPH	2,556	P1F	371	30.2	90.5	28.100	208-230/460V	
30	3600	284HP	03036ES3E284HP	2,695	P1F	395	35.1	89.5	26.350	208-230/460V	♣
	3600	286HP	03036ES3E286HP	2,772	P1F	399	35.1	89.5	27.845	208-230/460V	
	3600	286HPH	03036ES3E286HPH	2,772	P1F	399	35.1	89.5	29.595	208-230/460V	
	1800	286HP	03018ES3E286HP	2,730	P1F	393	36.1	91.0	27.845	208-230/460V	
	1800	286HPH	03018ES3E286HPH	2,730	P1F	393	36.1	91.0	29.595	208-230/460V	
40	3600*	286HP	04036ES3E286HP	3,329	P1F	404	48.6	90.2	27.845	208-230/460V	♣
	3600	324HP	04036ES3E324HP	3,584	P1F	515	47.4	90.4	30.403	208-230/460V	
	1800	324HP	04018ES3E324HP	3,476	P1F	506	48.3	91.7	30.403	208-230/460V	
50	3600	324HP	05036ES3E324HP	3,899	P1F	563	57.0	92.2	30.403	208-230/460V	♣
	3600	326HP	05036ES3E326HP	4,178	P1F	574	57.0	92.2	31.897	208-230/460V	
	1800	326HP	05018ES3E326HP	4,035	P1F	557	58.5	92.4	31.897	208-230/460V	
60	3600	326HP	06036ES3E326HP	5,533	P1F	640	70.5	92.0	31.897	208-230/460V	♣
	3600	364HP	06036ES3E364HP	6,147	P1F	948	68.5	91.7	33.684	208-230/460V	
	1800	326HP	06018ES3E326HP	6,074	P1F	640	72.0	92.5	31.897	208-230/460V	♣
	1800	364HP	06018ES3E364HP	6,966	P1F	948	70.0	93.0	33.684	208-230/460V	
75	3600	364HP	07536ES3E364HP	8,343	P1F	1058	83.0	92.4	33.684	208-230/460V	♣
	3600	365HP	07536ES3E365HP	8,654	P1F	1058	83.0	92.4	33.684	208-230/460V	
	1800	365HP	07518ES3E365HP	7,362	P1F	1025	84.5	93.0	33.684	208-230/460V	
100	3600	404HP	10036ES3E404HP	8,819	P1F	1180	111	93.0	36.674	208-230/460V	♣
	1800	405HP	10018ES3E405HP	8,762	P1F	1302	116	93.2	36.674	208-230/460V	♣
	1800	405HP	10018ES3G405HP	8,762	P1F	1302	116	93.2	36.674	460V	
	1800	405HPH	10018ES3E405HPH	8,762	P1F	1302	116	93.2	36.674	208-230/460V	
	1800	405HPH	10018ES3G405HPH	8,762	P1F	1302	116	93.2	36.674	460V	

• ELECTRICAL FEATURES ON PAGE B-34. • MECHANICAL FEATURES ON PAGE B-86.

♣ = Reduced Frame

PUMP MOTORS



HP & HPH TYPE – TEFC – STANDARD EFFICIENCY

HP	RPM	NEMA Frame	Catalog Number	List Price	Multi. Sym.	Approx. Shipp. Weight Lbs.	FL Amps 460	FL Eff %	“C” Dimension (in.)	Voltage	NOTES
125	3600	444HP	12536ES3G444HP	14,261	P1F	1797	138	93.0	40.012	460V	
	1800	444HP	12518ES3G444HP	12,450	P1F	1742	141	93.2	40.012	460V	
150	3600	445HP	15036ES3G445HP	16,283	P1F	1797	165	93.3	40.012	460V	
	1800	445HP	15018ES3G445HP	14,162	P1F	1940	170	93.5	40.012	460V	

- ELECTRICAL FEATURES ON PAGE B-34.
- MECHANICAL FEATURES ON PAGE B-59 & B-98.



HP & HPH TYPE – TEFC – HIGH EFFICIENCY

HP	RPM	NEMA Frame	Catalog Number	List Price	Multi. Sym.	Approx. Shipp. Weight Lbs.	FL Amps 460	FL Eff %	“C” Dimension (in.)	Voltage	NOTES
1	1800	143HP	00118EP3E143HP	503	P1F	47	1.49	82.5	13.421	208-230/460V	
1.5	3600	143HP	00156EP3E143HP	546	P1F	45	1.99	82.5	13.421	208-230/460V	
	1800	145HP	00158EP3E145HP	529	P1F	54	2.05	84.0	14.397	208-230/460V	
2	3600	145HP	00236EP3E145HP	553	P1F	47	2.60	84.0	14.397	208-230/460V	
	1800	145HP	00218EP3E145HP	583	P1F	56	2.70	84.0	14.397	208-230/460V	
3	3600	145HP#	00336EP3E145HP	822	P1F	54	3.71	85.5	14.397	208-230/460V	
	3600	182HP	00336EP3E182HP	881	P1F	106	3.59	85.5	15.504	208-230/460V	
	1800	182HP	00318EP3E182HP	879	P1F	97	3.90	87.5	15.504	208-230/460V	
5	3600	184HP	00536EP3E184HP	1,032	P1F	114	5.90	87.5	16.504	208-230/460V	
	1800	184HP	00518EP3E184HP	995	P1F	102	6.48	87.5	16.504	208-230/460V	
7.5	3600	184HP#	00736EP3E184HP	1,268	P1F	128	8.76	88.5	16.504	208-230/460V	
	3600	213HP	00736EP3E213HP	1,371	P1F	150	8.66	88.5	18.630	208-230/460V	
	1800	213HP	00718EP3E213HP	1,306	P1F	150	9.53	89.5	18.630	208-230/460V	
10	3600	215HP	01036EP3E215HP	1,645	P1F	150	11.7	89.5	20.126	208-230/460V	
	1800	215HP	01018EP3E215HP	1,563	P1F	165	12.8	90.2	20.126	208-230/460V	
15	3600	215HP#	01536EP3E215HP	2,133	P1F	174	17.3	90.2	20.126	208-230/460V	
	3600	254HP	01536EP3E254HP	2,345	P1F	280	17.0	90.2	23.723	208-230/460V	
	1800	254HP	01518EP3E254HP	2,346	P1F	266	17.9	91.0	23.723	208-230/460V	
20	3600	254HP#	02036EP3E254HP	2,608	P1F	304	23.3	90.2	23.723	208-230/460V	
	3600	256HP	02036EP3E256HP	2,814	P1F	313	23.3	90.2	25.455	208-230/460V	
	1800	256HP	02018EP3E256HP	2,591	P1F	313	24.4	91.0	25.455	208-230/460V	
25	3600	256HP#	02536EP3E256HP	3,177	P1F	313	28.4	91.0	25.455	208-230/460V	
	3600	284HP	02536EP3E284HP	3,454	P1F	353	29.0	91.0	26.350	208-230/460V	
	3600	284HPH	02536EP3E284HPH	3,454	P1F	353	29.0	91.0	28.100	208-230/460V	
	1800	284HP	02518EP3E284HP	3,451	P1F	437	29.6	92.4	26.350	208-230/460V	
	1800	284HPH	02518EP3E284HPH	3,451	P1F	437	29.6	92.4	28.100	208-230/460V	

- ELECTRICAL FEATURES ON PAGE B-35.
- MECHANICAL FEATURES ON PAGE B-86.
- ♣ = Reduced Frame

PUMP MOTORS



HP & HPH TYPE – TEFC HIGH EFFICIENCY

HP	RPM	NEMA Frame	Catalog Number	List Price	Multi. Sym.	Approx. Shipp. Weight Lbs.	FL Amps 460	FL Eff %	“C” Dimension (in.)	Voltage	NOTES
30	3600	284HP#	03036EP3E284HP	3,848	P1F	399	33.8	91.0	26.350	208-230/460V	
	3600	286HP	03036EP3E286HP	4,157	P1F	404	33.8	91.0	27.845	208-230/460V	
	3600	286HPH	03036EP3E286HPH	4,157	P1F	404	33.8	91.0	29.595	208-230/460V	
	1800	286HP	03018EP3E286HP	3,778	P1F	481	34.4	92.4	27.845	208-230/460V	
	1800	286HPH	03018EP3E286HPH	3,778	P1F	481	34.4	92.4	29.595	208-230/460V	
40	3600	286HP#	04036EP3E286HP	4,914	P1F	448	46.6	91.7	27.845	208-230/460V	
	3600	324HP	04036EP3E324HP	5,197	P1F	561	46.1	91.7	30.403	208-230/460V	
	1800	324HP	04018EP3E324HP	4,997	P1F	587	47.6	93.0	30.403	208-230/460V	
50	3600*	324HP#	05036EP3E324HP	6,153	P1F	565	56.5	92.4	30.403	208-230/460V	
	3600	326HP	05036EP3E326HP	6,363	P1F	594	56.5	92.4	31.897	208-230/460V	
	1800	326HP	05018EP3E326HP	5,723	P1F	640	57.8	93.6	31.897	208-230/460V	
60	3600	326HP#	06036EP3E326HP	8,221	P1F	594	69.0	93.0	31.897	208-230/460V	
	3600	364HP	06036EP3E364HP	9,032	P1F	917	69.0	93.0	33.684	208-230/460V	
	1800	326HP#	06018EP3E326HP	7,641	P1F	640	71.0	93.6	31.897	208-230/460V	
	1800	364HP	06018EP3E364HP	8,119	P1F	963	67.0	93.6	33.684	208-230/460V	
75	3600	365HP	07536EP3E365HP	10,454	P1F	1025	82.5	93.0	33.684	208-230/460V	
	1800	365HP	07518EP3E365HP	8,907	P1F	1010	82.4	94.1	33.684	208-230/460V	
100	3600	405HP	10036EP3E405HP	12,293	P1F	1361	113	93.6	36.674	208-230/460V	
	3600	405HP	10036EP3G405HP	12,293	P1F	1361	113	93.6	36.674	460V	
	3600	405HPH	10036EP3E405HPH	12,293	P1F	1361	113	93.6	36.674	208-230/460V	
	3600	405HPH	10036EP3G405HPH	12,293	P1F	1361	113	93.6	36.674	460V	
	1800	405HP	10018EP3E405HP	10,688	P1F	1273	115	94.5	36.674	208-230/460V	
	1800	405HP	10018EP3G405HP	10,688	P1F	1273	115	94.5	36.674	460V	
	1800	405HPH	10018EP3E405HPH	10,688	P1F	1273	115	94.5	36.674	208-230/460V	
	1800	405HPH	10018EP3G405HPH	10,688	P1F	1273	115	94.5	36.674	460V	
125	3600	444HP	12536EP3G444HP	17,113	P1F	1801	131	94.5	40.012	460V	
	1800	444HP	12518EP3G444HP	14,940	P1F	1647	138	94.5	40.012	460V	
150	3600	445HP	15036EP3G445HP	19,540	P1F	1865	160	94.5	40.012	460V	
	1800	445HP	15018EP3G445HP	16,995	P1F	1841	168	95.0	40.012	460V	

• ELECTRICAL FEATURES ON PAGE B-34.

• MECHANICAL FEATURES ON PAGE B-86.

♣ = Reduced Frame

PUMP MOTORS

THREE PHASE

These special motors have the high slip and high torque that oil well beam pumping units demand. WEG oil well pumping motors are requested on specifications for most major oil companies around the world as a result of their long lasting performance, low purchase and maintenance cost.

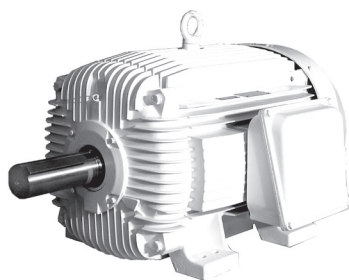

TEFC

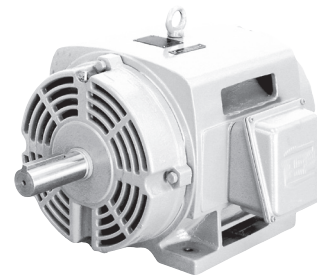

ODP

HIGHLIGHTS

- High slip and torque

APPLICATIONS

- Beam Pumps
- Sucker Rod Pumps
- Other applications requiring high starting torque or high slip

OPTIONAL FEATURES

- Special voltages
- Other mountings
- Specially designed shaft
- Space heaters
- Second shaft end
- Thermistors, Thermostats or RTD's (PT100)
- Additional terminal box
- Stainless steel shaft
- 575V

FRAME – SPECIFIC FEATURES (ODP ONLY)

For Frames 184T and 213/5T only (ODP only)

- Welded steel plate frames (welded feet)
- Aluminum endshields and terminal box
- Cooling system with finned rotor
- ZZ bearing (double shielded)
- Degree of protection: IP21
- Service factor: 1.0

For Frames 254/6T and up (ODP only)

- Cast iron frames
- Cast iron endshields and terminal box
- Cooling system with finned rotor
- Regreasable bearings positive pressure lubrication system (frame 254T and up)
- Degree of protection: IP23
- Rodent screen
- Service factor: 1.0

ONLY FOR TEFC (IP55 MOTORS)

- V-ring slingers on both endshields
- Service factor: 1.15

HIGH STARTING and BREAKDOWN TORQUE -

NEMA DESIGN 'D' (5 - 8% SLIP)

- Single and triple rated available
- Three-phase, 60Hz
- Voltage: 208-230/460
- 184T up to 445T cast iron frames
- 6 and 8 pole
- Squirrel cage rotor / Aluminum die cast
- Ball bearings are supplied as standard (100 HP & above Roller Bearings)
- 1045 Carbon Steel Shaft for frames up to 365T. 4140 steel shaft for motors 404T and above.
- Enclosure: Open Drip Proof (ODP) and Totally Enclosed Fan Cooled (TEFC)
- Dimensions according to NEMA standard
- Class 'F' insulation ('B' temperature rise)
- Continuous duty (S1)
- 104°F (40°C) ambient temperature
- Altitude: 3300 ft (1000m)
- F2 mount
- Stainless steel nameplate
- Paint: Enamel alkyd resin base
- NPT threaded terminal box
- Plastic drain plugs
- Regreasable bearings system (frames 254T and up)
- Shaft slingers (V-ring)(TEFC only)
- Rodent screens (ODP only)
- Service factor: 1.00 (ODP only)
- Service factor: 1.15 (TEFC only)
- Color: RAL 9010 (White)
- Roller bearings on frame 404T and up

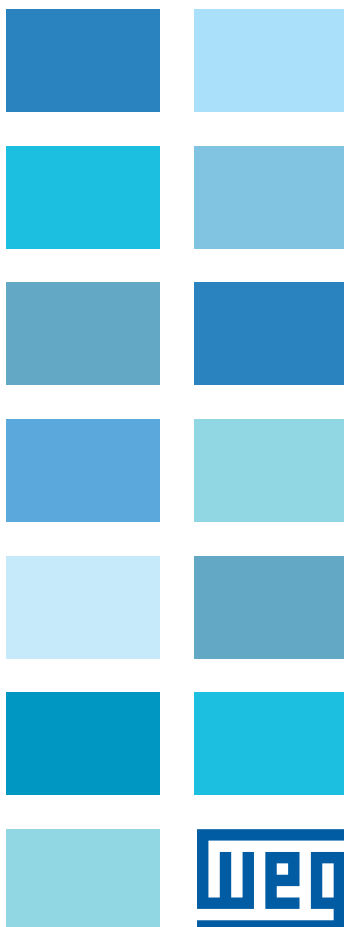

PUMP MOTORS





HIGH SLIP – NEMA DESIGN ‘D’ ODP WITH SCREENS

HP	RPM	NEMA Frame	Catalog Number	List Price	Multi. Sym.	Approx. Shipp. Weight Lbs.	FL Amps 460	FL Eff %	“C” Dimension (in.)	Voltage	NOTES
1.5	1200	184T	001520S2E0W184T	776	P1E	68	2.70	71.0	14.291	208-230/460V	
2	1200	184T	002120S3E0W184T	793	P1E	79	3.20	81.3	14.291	208-230/460V	
3	1200	213T	003120S3E0W213T	866	P1E	101	4.70	80.7	17.165	208-230/460V	
5	1200	215T	005120S3E0W215T	989	P1E	128	7.10	86.5	17.165	208-230/460V	
7.5	1200	254T	007120S3E0W254T	1,434	P1E	280	10.2	79.0	20.669	208-230/460V	
10	1200	256T	010120S3E0W256T	1,796	P1E	416	13.7	80.0	22.401	208-230/460V	
15	1200	284T	015120S3E0W284T	2,441	P1E	438	18.2	86.5	23.386	208-230/460V	
20	1200	286T	020120S3E0W286T	2,603	P1E	600	24.5	86.5	24.882	208-230/460V	
25	1200	324T	025120S3E0W324T	3,247	P1E	613	33.2	87.5	26.181	208-230/460V	
30	1200	326T	030120S3E0W326T	3,848	P1E	745	39.1	87.8	27.667	208-230/460V	
40	1200	365T	040120S3E0W365T	5,277	P1E	970	50.0	89.5	29.764	208-230/460V	
50	1200	405T	050120S3E0W405T	6,834	P1E	1200	61.3	90.2	34.133	208-230/460V	
60	1200	405T	060120S3E0W405T	7,495	P1E	1355	75.0	88.5	34.133	208-230/460V	
75	1200	445T	075120S3E0W445T	12,308	P1E	1476	95.7	90.2	39.803	208-230/460V	
100	1200	445T	100120S3E0W445T	13,078	P1E	2161	127	90.2	39.803	208-230/460V	

- ELECTRICAL FEATURES ON PAGE B-36.
- MECHANICAL FEATURES ON PAGE B-87, B-88.

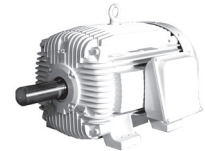

HIGH SLIP – NEMA DESIGN ‘D’ – TEFC

HP	RPM	NEMA Frame	Catalog Number	List Price	Multi. Sym.	Approx. Shipp. Weight Lbs.	FL Amps 460	FL Eff %	“C” Dimension (in.)	Voltage	NOTES
3	1200	215T	00312ES3E0W215T	1,027	P1E	128	5.00	75.7	19.517	208-230/460V	
5	1200	215T	00512ES3E0W215T	1,170	P1E	183	7.40	77.5	19.517	208-230/460V	
	900	256T	00509ES3E0W256T	2,242	P1E	284	7.25	77.0	24.945	208-230/460V	
7.5	1200	254T	00712ES3E0W254T	1,688	P1E	280	9.25	85.6	23.213	208-230/460V	
10	1200	256T	01012ES3E0W256T	2,070	P1E	326	12.5	85.6	24.945	208-230/460V	
	900	286T	01009ES3E0W286T	3,437	P1E	382	13.9	82.5	27.929	208-230/460V	
15	1200	284T	01512ES3E0W284T	2,679	P1E	455	18.0	87.1	26.433	208-230/460V	
	900	324T	01509ES3E0W324T	4,293	P1E	548	19.5	85.5	29.620	208-230/460V	
20	1200	286T	02012ES3E0W286T	3,162	P1E	488	24.5	87.3	27.929	208-230/460V	
	900	326T	02009ES3E0W326T	4,872	P1E	656	26.2	85.5	31.116	208-230/460V	
25	1200	324T	02512ES3E0W324T	3,887	P1E	607	30.0	88.9	29.620	208-230/460V	
30	1200	326T	03012ES3E0W326T	4,515	P1E	656	35.5	89.4	31.116	208-230/460V	
40	1200	365T	04012ES3E0W365T	6,290	P1E	950	52.5	87.5	33.709	208-230/460V	
50	1200	404T	05012ES3E0W404T	8,172	P1E	1189	62.0	88.1	38.077	208-230/460V	
60	1200	405T	06012ES3E0W405T	9,414	P1E	1500	78.5	89.0	38.077	208-230/460V	
75	1200	444T	07512ES3E0W444T	14,976	P1E	1720	90.0	87.0	43.776	208-230/460V	
100	1200	445T	10012ES3E0W445T	18,074	P1E	2039	115	88.0	43.776	208-230/460V	

- ELECTRICAL FEATURES ON PAGE B-36.
- MECHANICAL FEATURES ON PAGE B-87, B-88.

“Global presence means:
We are there.
Global service means:
We are there for you.”

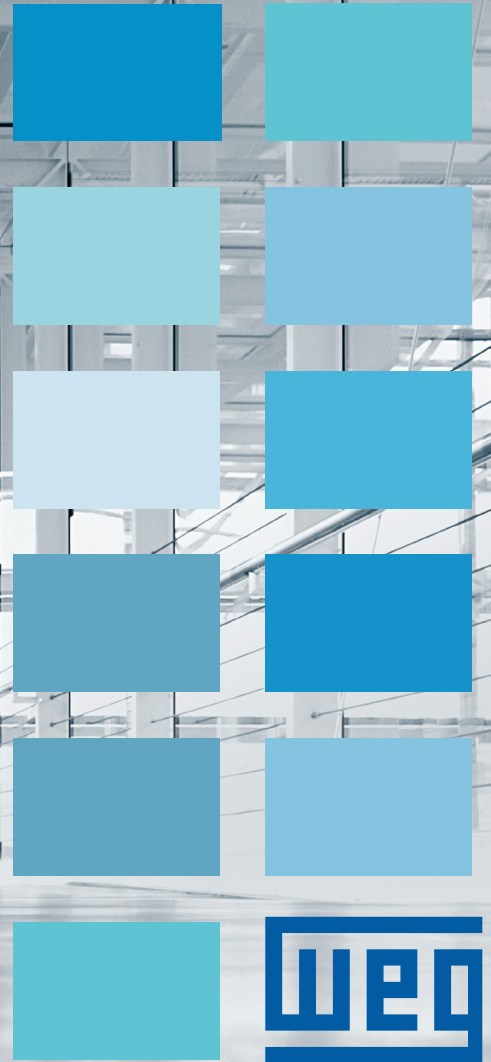

Great customer service is our trademark at WEG. We service all global markets so that it feels local from your point of view. That's why WEG Technicians are always closer than you might think. To learn more about our solutions with electric motors, automation, controls, transformers and generators or for a U.S. distributor near you, call 1-800-ASK-4WEG.

Transforming energy into solutions. www.weg.net

SINGLE PHASE

These motors are specially designed for Pool Duty. Available in High Service Factor and Low Service Factor with C-Face or Square Flange.



C-Face



Square-Flange

APPLICATIONS

- Pool and Spa

STANDARD FEATURES

- Single-phase, 2 pole, 60Hz
- Voltage: 115/230V or 230V
- Cast Iron C-face or Aluminum Square Flange
- Open Drip Proof (ODP) IP21
- Dual Compartment up to 2 1/2HP
- 50°C Ambient
- Class 'B' insulation
- CCW (Pump end) - non reversible
- AISI 316 Stainless Steel Shaft
- Automatic overload protection
- Threaded Shaft
- Internal and external grounding
- Terminal box threaded NPT 1/2"
- D.E. sealed ball bearings
- D.E. Endshield sealing - V-ring
- Epoxy Coating
- '1081' Design

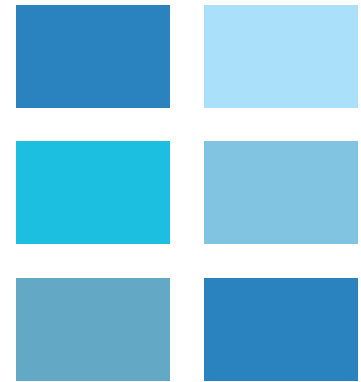

WEG MOTOR ITEM CODIFICATION FOR POOL AND SPA (MODEL NUMBERS)

THE WEG MODEL NUMBERS ARE DISTRIBUTED AS FOLLOWS:

X
(Product Line)

X
(Capacitor)

X
(Flange)

XXX
(HP)

X
(Service Factor)
Blank=Low / H=High

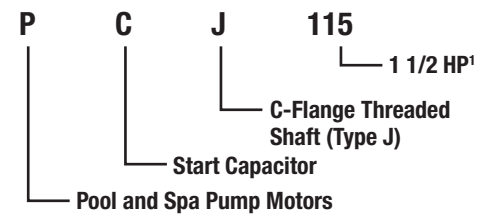
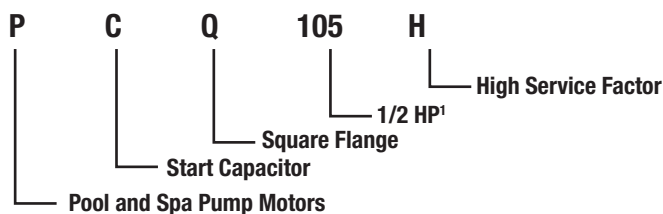

HP¹ – 1/3HP (103) 1/2HP (105) 3/4HP (107) 1HP (110) 1 1/2HP (115) 2HP (120) 2 1/2HP (125) 3HP (130)



C-FACE – ODP – START CAPACITOR

HP	RPM	NEMA Frame	Catalog Number	List Price	Multi. Sym.	Approx. Shipp. Weight Lbs.	Service Factor	FL Amps 460	FL Eff %	“C” Dimension (in.)	Voltage	NOTES
1/2	3600	K56J	PCJ105H	236	P1D	20	1.6	4.50	62.0	14.035	115/230V	
3/4	3600	K56J	PCJ107H	263	P1D	24	1.5	5.50	69.0	14.035	115/230V	
1	3600	L56J	PCJ110H	300	P1D	27	1.4	7.20	70.0	14.626	115/230V	
1 1/2	3600	M56J	PCJ115H	400	P1D	30	1.3	7.20	75.0	15.216	230V	▲
2	3600	M56J	PCJ120H	486	P1D	32	1.2	8.60	80.0	15.216	230V	▲

High Service Factor - Full Rate

HP	RPM	NEMA Frame	Catalog Number	List Price	Multi. Sym.	Approx. Shipp. Weight Lbs.	Service Factor	FL Amps 460	FL Eff %	“C” Dimension (in.)	Voltage	NOTES
3/4	3600	K56J	PCJ107	236	P1D	20	1.3	5.20	67.0	14.035	115/230V	
1	3600	K56J	PCJ110	263	P1D	24	1.25	6.30	72.0	14.035	115/230V	
1 1/2	3600	L56J	PCJ115	300	P1D	27	1.1	8.90	72.0	14.626	115/230V	
2	3600	M56J	PCJ120	400	P1D	30	1.1	9.20	77.0	15.216	230V	▲
2 1/2	3600	M56J	PCJ125	486	P1D	32	1.04	10.6	80.0	15.216	230V	▲

Low Service Factor - Up Rate



SQUARE FLANGE – ODP – START CAPACITOR

HP	RPM	NEMA Frame	Catalog Number	List Price	Multi. Sym.	Approx. Shipp. Weight Lbs.	Service Factor	FL Amps 460	FL Eff %	“C” Dimension (in.)	Voltage	NOTES
1/3	3600	K48Y	PCQ103H	231	P1D	18	1.95	3.40	54.0	13.032	115/230V	
1/2	3600	K48Y	PCQ105H	241	P1D	20	1.9	4.50	62.0	13.032	115/230V	
3/4	3600	K48Y	PCQ107H	275	P1D	24	1.65	5.50	69.0	13.032	115/230V	
1	3600	L48Y	PCQ110H	320	P1D	27	1.65	7.20	70.0	13.622	115/230V	
1 1/2	3600	M48Y	PCQ115H	411	P1D	30	1.5	7.20	75.0	14.213	230V	▲
2	3600	M48Y	PCQ120H	500	P1D	32	1.3	8.60	80.0	14.213	230V	▲

High Service Factor - Full Rate

HP	RPM	NEMA Frame	Catalog Number	List Price	Multi. Sym.	Approx. Shipp. Weight Lbs.	Service Factor	FL Amps 460	FL Eff %	“C” Dimension (in.)	Voltage	NOTES
1/2	3600	K48Y	PCQ105	231	P1D	18	1.3	3.80	63.0	13.032	115/230V	
3/4	3600	K48Y	PCQ107	241	P1D	20	1.3	5.20	67.0	13.032	115/230V	
1	3600	K48Y	PCQ110	275	P1D	24	1.25	6.30	72.0	13.032	115/230V	
1 1/2	3600	L48Y	PCQ115	320	P1D	27	1.1	8.90	72.0	13.622	115/230V	
2	3600	M48Y	PCQ120	411	P1D	30	1.1	9.20	77.0	14.213	230V	▲
2 1/2	3600	M48Y	PCQ125	500	P1D	32	1.04	10.6	80.0	14.213	230V	▲

▲ = Energy Efficiency • ELECTRICAL FEATURES ON PAGE B-37. • MECHANICAL FEATURES ON PAGE B-90.

PUMP MOTORS

CROSS REFERENCE

TYPE		HP	RPM	FRAME	WEG CATALOG NUMBER	A.O. SMITH/MAGNATEK CATALOG NUMBER	A.O. SMITH CATALOG NUMBER	
START CAPACITOR	C-FLANGE (Threaded Shaft)	HIGH SERVICE FACTOR	1/2	3600	K56J	PCJ105H	B986 (NEPTUNE)	ST1052
			3/4	3600	K56J	PCJ107H	B988 (NEPTUNE)	ST1072
			1	3600	L56J	PCJ110H	B990 (NEPTUNE)	ST1102
			1 1/2	3600	M56J	PCJ115H	B992 (NEPTUNE)	ST1152 2)
			2	3600	M56J	PCJ120H	B993 (NEPTUNE)	ST1202
			3/4	3600	K56J	PCJ107	B995 (NEPTUNE)	UST1072
		LOW SERVICE FACTOR	2	3600	K56J	PCJ110	B996 (NEPTUNE)	UST1102
			1 1/2	3600	L56J	PCJ115	B997 (NEPTUNE)	UST1152
			2	3600	M56J	PCJ120	B998 (NEPTUNE)	UST1202
			2 1/2	3600	M56J	PCJ125	B999 (NEPTUNE)	UST1252
			1/3	3600	K48Y	PCQ103H	B879 (NEPTUNE)	SQ1032
			1/2	3600	K48Y	PCQ105H	B880 (NEPTUNE)	SQ1052
	SQUARE FLANGE	HIGH SERVICE FACTOR	3/4	3600	K48Y	PCQ107H	B881 (NEPTUNE)	SQ1072
			1	3600	L48Y	PCQ110H	B883 (NEPTUNE)	SQ1102
			1 1/2	3600	M48Y	PCQ115H	B875 (NEPTUNE)	SQ1152 4)
			2	3600	M48Y	PCQ120H	B877 (NEPTUNE)	SQ1202
			1/2	3600	K48Y	PCQ105	B882 (NEPTUNE)	USQ1052
			3/4	3600	K48Y	PCQ107	B885 (NEPTUNE)	USQ1072
			1	3600	K48Y	PCQ110	B886 (NEPTUNE)	USQ1102
			1 1/2	3600	L48Y	PCQ115	B887 (NEPTUNE)	USQ1152
		LOW SERVICE FACTOR	2	3600	M48Y	PCQ120	B876 (NEPTUNE)	USQ1202 4)
			2 1/2	3600	M48Y	PCQ1225	B884 (NEPTUNE)	USQ1252