



# CFW 09

## VECTRUE INVERTER

- User's Guide **Frequency Inverter**
- Guia del Usuario **Convertidores de Frecuencia**
- Manual do Usuário **Inversores de Freqüência**
- *Bedienungsanleitung* **Frequenzumrichter**
- Guide d'instalation et d'exploitation **Variateur de Vitesse**
- *Installatie en gebruikshandleiding* **Frequentie-Omzetter**
- Bruksanvisning **Frekvensomriktare**
- Руководство по эксплуатации преобразователя частоты





# FREQUENCY INVERTER MANUAL

**Series:** CFW-09

**Software Version:** 3.7X

**Manual Number/Revision:**

0899.5306 E/11

---

07/2006



## **ATTENTION!**

It is very important to check if the inverter software version is the same as indicated above.

## Summary of Revisions

The table below describes all revisions made to this manual.

Revision	Description	Section
1	First Edition.	-
2	Inclusion of the functions Fieldbus and Serial Communication.	See 8.12 and 8.13
2	Inclusion of the Spare Part List.	See 7.5
2	Dimension Changing.	See 3.1.2 and 9.4
3	Inclusion of the PID Regulator.	See item 6
4	Inclusion of the German Language - Ride-through and Flying-start functions	See item 6
4	Inclusion of DBW-01; KIT KME; DC Link Inductor	See item 8
5	Inclusion of item 3.3 - CE Installation	See item 3
5	Inclusion of new functions such as Ride-Through for Vector Control, Motor Phase Loss .	See item 6
5	New I/O Expansion Boards EBB.04 and EBB.05.	See item 8
6	General Revision.	-
7	Inclusion of the models from 2.9 to 32A / 500-600V.	See 2.4; 3.1; 3.2.1; 3.3; 4.2; 6.2; 6.3; 7.1; 7.2; 7.4; 7.5; 8.7.1; 8.10.1; 9.1 and 9.1.3
8	Inclusion of new functions: Control Type of the Speed Regulator, Speed Regulator Differential Gain, Stop Mode Selection, Access to the parameters with different content than default, Hysteresis for Nx/Ny, kWh Counter, Load User 1 and 2 the factory Hours Hx, via DIx, Parameter Setting Disable via DIx, Help Message for E24, "P406=2 in Vector Control", Automatic SensorLess Set of P525, Last 10 errors indication, Motor Torque indication via AOx.	See item 6
8	New optional boards: EBC and PLC1.	See item 8
8	New model CFW-09 SHARK NEMA 4X/IP56.	See item 8
8	New models for voltages, currents and powers: Models 500-600V.	See itens 1 to 9
8	Inclusion of the itens 8.14 Modbus-RTU, 8.17 CFW-09 Supplied by the DC Link - Line HD, 8.18 CFW-09 RB Regenerative Converter.	See item 8
8	Updating of the Spare Part List.	7
9	Inclusion of new functions: Overcurrent Protection, Default factory reset 50Hz, Timer Relay, Ramp Holding	-
9	New lines of the Current and supply power;	-
9	PID Regulator to "Academic" Changing.	-
10	General revision and update of the software version (2.6X to 3.1X): Change on the maximum value of P156 and P401 for some models; Change on the maximum value of P331; Change on the factory default value of P404.	-
11	New functions; Incorporation of the Mechanical Brake Logic for cranes, Load Detection Logic and addition of option "Indication of Torque Current Polarity" at the DOx and RLx outputs; VVW Control; DC Braking for VVW and Sensorless; Flying Start function for the Sensorless Control; support for Ethernet/IP communication board; read/write function for the PLC board parameters through Modbus; Indication of the Analog Outputs values in read only parameters P027 to P030; Simultaneous indication of the speed and current in parameter P070; P313 = 4 (Changes to LOCAL mode keeping the commands); Regulation of the maximum torque current through options AI1+AI2 and AI2+AI3; function F > Fx; function ready 2	See I, 6, 7 and 8

Quick Parameter Reference, Fault and Status Messages

I. Parameters ..... 09  
 II. Fault messages ..... 33  
 III. Other messages ..... 33

**CHAPTER 1**

Safety Notices

1.1 Safety notices in the manual ..... 34  
 1.2 Safety notices on the product ..... 34  
 1.3 Preliminary recommendations ..... 34

**CHAPTER 2**

General Information

2.1 About this manual ..... 36  
 2.2 Software version ..... 36  
 2.3 About the CFW-09 ..... 36  
 2.4 CFW-09 identification Label and Code Number ..... 38  
 2.5 Receiving and Storage ..... 40

**CHAPTER 3**

Installation

3.1 Mechanical installation ..... 41  
 3.1.1 Environment conditions ..... 41  
 3.1.2 Dimensional of CFW-09 ..... 41  
 3.1.3 Mounting specifications ..... 42  
     3.1.3.1 Mounting Inside a Panel ..... 43  
     3.1.3.2 Mounting on Surface ..... 44  
     3.1.3.3 Mounting with the heatsink through a surface ..... 45  
 3.1.4 Keypad (HMI) and cover removal ..... 47  
 3.2 Electrical installation ..... 48  
 3.2.1 Power/grounding terminals ..... 48  
 3.2.2 Location of the power/grounding/control connections ..... 50  
 3.2.3 Rated voltage selection ..... 52  
 3.2.4 Power/Grounding Wiring and Fuses ..... 53  
 3.2.5 Power Connections ..... 56  
     3.2.5.1 AC Input Connection ..... 56  
     3.2.5.2 Output Connections ..... 57  
     3.2.5.3 Grounding connections ..... 57  
     3.2.5.4 IT Networks ..... 58  
 3.2.6 Control Wiring ..... 60  
 3.2.7 Typical Terminal Connections ..... 63  
 3.3 European EMC Directive - requirements for conforming installations .. 66  
 3.3.1 Installation ..... 66  
 3.3.2 Epcos filters ..... 67  
 3.3.3 Schaffner filters definitions ..... 70  
 3.3.4 EMC filter characteristics ..... 73

**CHAPTER 4**

**Keypad (HMI) Operation**

4.1 Discription of the Keypad .....	87
4.2 Use of the Keypad (HMI) .....	89
4.2.1 Keypad Operation .....	89
4.2.2 "Read-Only" Variables and Status .....	90
4.2.3 Parameter Viewing and Programming .....	91

**CHAPTER 5**

**Start-up**

5.1 Pre-Power Checks .....	94
5.2 Initial Power-up .....	94
5.3 Start-up .....	99
5.3.1 Type of Control: V/F 60Hz - Operation via Keypad (HMI) .....	100
5.3.2 Type of Control: Sensorless or Vector with Encoder (Operation Via Keypad (HMI)) .....	103
5.3.3 Type of Control: VVW - Keypad Operation .....	110

**CHAPTER 6**

**Detailed Parameter Description**

6.1 Access and Read Only Parameters - P000 to P099 .....	119
6.2 Regulation Parameters - P100 to P199 .....	125
6.3 Configuration Parameters - P200 to P399 .....	148
6.3.1 Parameters for Crane Applications and for Torque Master/Slave Function - P351 to P368 .....	207
6.4 Motor Parameters - P400 to P499 .....	213
6.5 Special Functions Parameters - P500 to P699 .....	219
6.5.1 PID Regulator .....	219
6.5.2 Description .....	219

**CHAPTER 7**

**Diagnostics and Troubleshooting**

7.1 Faults and Possible Causes .....	227
7.2 Troubleshooting .....	232
7.3 Contacting WEG .....	234
7.4 Preventive Maintenance .....	234
7.4.1 Cleaning Instructions .....	235
7.5 Spare Part List .....	236

**CHAPTER 8**

**CFW-09 Options and Accessories**

8.1 I/O Expansion Boards .....	247
8.1.1 EBA (I/O Expansion Board A) .....	247

---

8.1.2 EBB (I/O Expansion Board B) .....	250
8.1.3 EBE .....	253
8.2 Incremental Encoder .....	253
8.2.1 EBA/EBB Boards .....	253
8.2.2 EBC Board .....	255
8.3 Keypad with Led's Only .....	257
8.4 Remote Keypad and Cables .....	257
8.5 Blank Covers .....	261
8.6 RS-232 PC Communication Kit .....	261
8.7 Line Reactor/DC Bus Choke .....	262
8.7.1 Application Criteria .....	263
8.7.2 DC link Inductor Built in .....	265
8.8 Load Reactor .....	266
8.9 RFI Filter .....	266
8.10 Dynamic Braking .....	267
8.10.1 DB Resistor Sizing .....	267
8.10.2 Installation .....	269
8.10.3 Dynamic Braking Module-DBW-01 and DBW-02 .....	270
8.10.3.1 DBW-01 and DBW-02 Identification Label .....	271
8.10.3.2 Mechanical Installation .....	271
8.10.3.3 Installation/Connection .....	274
8.11 Through Surface Mounting Kit .....	276
8.12 Fieldbus .....	276
8.12.1 Installation of the Fieldbus Kit .....	277
8.12.2 Profibus-DP .....	280
8.12.3 Device-Net .....	282
8.12.4 Ethernet/IP .....	285
8.12.5 Use to the Fieldbus/Related Parameters of the CFW-09. ....	292
8.12.5.1 Variables Read from the Inverter .....	292
8.12.5.2 Variables Written in the Inverter .....	294
8.12.5.3 Fault Indications .....	296
8.12.5.4 Addressing of the CFW-09 variables in the Fieldbus ...	297
8.13 Serial Communication .....	298
8.13.1 Introduction .....	298
8.13.2 Interfaces Description .....	299
8.13.2.1 RS-485 .....	299
8.13.2.2 RS-232 .....	300
8.13.3 Protocol Definitions .....	300
8.13.3.1 Used Terms .....	300
8.13.3.2 Parameters/Variables Resolution .....	301
8.13.3.3 Characters Format .....	301
8.13.3.4 Protocol .....	301
8.13.3.5 Execution and Telegram Test .....	303
8.13.3.6 Telegram Sequence .....	304
8.13.3.7 Variable Code .....	304
8.13.4 Telegram Examples .....	304
8.13.5 Variables and Errors of the Serial Communication .....	305
8.13.5.1 Basic Variables .....	305
8.13.5.2 Examples of Telegrams with Basic Variables .....	308
8.13.5.3 Parameters Related to the Serial Communication .....	309
8.13.5.4 Errors Related to the Serial Communication .....	310
8.13.6 Times for Read/Write of Telegrams .....	310
8.13.7 Physical Connection of the RS-232 and RS-485 Interface .....	311
8.14 Modbus-RTU .....	312
8.14.1 Introduction in the Modbus-RTU Protocol .....	312
8.14.1.1 Transmission Modes .....	312

8.14.1.2 Message Structure in RTU Mode .....	312
8.14.2 Operation of the CFW-09 in the Modbus-RTU Network .....	314
8.14.2.1 Interface RS-232 and RS-485 Description .....	314
8.14.2.2 Inverter Configuration in the Modbus-RTU Network .....	315
8.14.2.3 Access to the Inverter Data .....	315
8.14.3 Detailed Function Description .....	318
8.14.3.1 Function 01 - Read Coils .....	319
8.14.3.2 Function 03 - Read Holding Register .....	319
8.14.3.3 Function 05 - Write Single Coil .....	320
8.14.3.4 Function 06 - Write Single Register .....	321
8.14.3.5 Function 15 - Write Multiple Coils .....	322
8.14.3.6 Function 16 - Write Multiple Registers .....	323
8.14.3.7 Function 43 - Read Device Identification .....	324
8.14.4 Communication Errors .....	325
8.14.4.1 Error Messages .....	325
8.15 KIT KME (for Extractable Mounting) .....	327
8.16 CFW-09 SHARK NEMA 4X .....	328
8.16.1 Enclosure Specifications .....	328
8.16.2 Mechanical Installation .....	328
8.16.3 Electrical Installation .....	330
8.16.4 Closing the Drive .....	330
8.16.5 How to Specify .....	331
8.17 CFW-09 Supplied by the DC link - line HD .....	331
8.18 CFW-09 RB Regenerative Converter .....	331
8.19 PLC Board .....	333

## **CHAPTER 9**

### **Technical Specification**

9.1 Power Data .....	334
9.1.1 Power supply specifications .....	334
9.1.2 220-230V Power Supply .....	335
9.1.3 380-480V Power Supply .....	335
9.1.4 500-600V Power Supply .....	336
9.1.5 660-690V Power Supply .....	338
9.2 Electronics/General Data .....	341
9.2.1 Applicable standards .....	342
9.3 Optional Devices .....	343
9.3.1 I/O Expansion Board EBA .....	343
9.3.2 I/O Expansion Board EBB .....	343
9.4 Mechanical Data .....	344

## QUICK PARAMETER REFERENCE, FAULT AND STATUS MESSAGES

Software: V3.7X

Application:

CFW-09 Model:

Serial Number:

Responsible:

Date:        /        /        .

### I. Parameters

Parameters	Function	Adjustable Range	Factory	Unit	User's	Page
<b>P000</b>	Parameter Access	0 to 999	0	-		119
<b>READ ONLY PARAMETERS</b>		<b>P001 to P099</b>				
<b>P001</b>	Speed Reference	0 to P134		rpm		119
<b>P002</b>	Motor Speed	0 to P134		rpm		119
<b>P003</b>	Motor Current	0 to 2600		A (rms)		119
<b>P004</b>	DC Link Voltage	0 to 1235		V		120
<b>P005</b>	Motor Frequency	0 to 1020		Hz		120
<b>P006</b>	Inverter Status	rdy run Sub EXY		-		120
<b>P007</b>	Motor Voltage	0 to 800		V		120
<b>P009</b>	Motor Torque	0 to 150.0		%		120
<b>P010</b>	Output Power	0.0 to 1200		kW		120
<b>P012</b>	Digital Inputs DI1 ... DI8 Status	0 = Inactive (Open) 1 = Active (Closed)		-		120
<b>P013</b>	Digital and Relay Outputs DO1, DO2, RL1, RL2, and RL3 Status	0 = Inactive (Dropped-out) 1 = Active (Picked-up)		-		121
<b>P014</b>	Last Fault	0 to 70		-		122
<b>P015</b>	Second Previous Fault	0 to 70		-		122
<b>P016</b>	Third Previous Fault	0 to 70		-		122
<b>P017</b>	Fourth Previous Fault	0 to 70		-		122
<b>P018</b>	Analog Input AI1' Value	-100 to +100		%		122
<b>P019</b>	Analog Input AI2' Value	-100 to +100		%		122
<b>P020</b>	Analog Input AI3' Value	-100 to +100		%		122
<b>P021</b>	Analog Input AI4' Value	-100 to +100		%		122
<b>P022</b>	WEG Use	0 to 100		%		122
<b>P023</b>	Software Version	X.XX		-		122
<b>P024</b>	A/D Conversion Value of AI4	-32768 to +32767		-		122
<b>P025</b>	A/D Conversion Value of Iv	0 to 1023		-		122
<b>P026</b>	A/D Conversion Value of Iw	0 to 1023		-		122
<b>P027</b>	AO1 Value	0 to 100		%		123
<b>P028</b>	AO2 Value	0 to 100		%		123
<b>P029</b>	AO3 Value	-100 to +100		%		123
<b>P030</b>	AO4 Value	-100 to +100		%		123
<b>P040</b>	PID Process Variable	0.0 to 100		%		123
<b>P042</b>	Powered Time	0 to 65530		h		123
<b>P043</b>	Enabled Time	0 to 6553		h		123
<b>P044</b>	kWh Counter	0 to 65535		kWh		124

**CFW-09 - QUICK PARAMETER REFERENCE**

Parameters	Function	Adjustable Range	Factory Setting	Unit	User's Setting	Page
P060	Fifth Error	0 to 70		-		124
P061	Sixth Error	0 to 70		-		124
P062	Seventh Error	0 to 70		-		124
P063	Eighth Error	0 to 70		-		124
P064	Ninth Error	0 to 70		-		124
P065	Tenth Error	0 to 70		-		124
P070	Motor Speed and Motor Current	0 to P134 0 to 2600		rpm A (rms)		124
P071	Command Word	0 a 65535		-		124
P072	Fieldbus Speed Reference	0 a 65535		-		124
<b>REGULATION PARAMETERS</b>		<b>P100 to P199</b>				
<b>Ramps</b>						
P100	Acceleration Time	0.0 to 999	20.0	s		125
P101	Deceleration Time	0.0 to 999	20.0	s		125
P102	Acceleration Time 2	0.0 to 999	20.0	s		125
P103	Deceleration Time 2	0.0 to 999	20.0	s		125
P104	S Ramp	0=Inactive (Linear) 1=50 2=100	0=Inactive	%		125
<b>Speed References</b>						
P120	Speed Reference Backup	0=Inactive 1=Active	1=Active	-		125
P121	Keypad Speed Reference	P133 to P134	90	rpm		126
P122 <sup>(2)(11)</sup>	JOG or JOG+ Speed Reference	00 to P134	150 (125) <sup>(11)</sup>	rpm		126
P123 <sup>(2)(11)</sup>	JOG- Speed Reference	00 to P134	150 (125) <sup>(11)</sup>	rpm		126
P124 <sup>(2)(11)</sup>	Multispeed Reference 1	P133 to P134	90 (75) <sup>(11)</sup>	rpm		127
P125 <sup>(2)(11)</sup>	Multispeed Reference 2	P133 to P134	300 (250) <sup>(11)</sup>	rpm		127
P126 <sup>(2)(11)</sup>	Multispeed Reference 3	P133 to P134	600 (500) <sup>(11)</sup>	rpm		127
P127 <sup>(2)(11)</sup>	Multispeed Reference 4	P133 to P134	900 (750) <sup>(11)</sup>	rpm		127
P128 <sup>(2)(11)</sup>	Multispeed Reference 5	P133 to P134	1200 (1000) <sup>(11)</sup>	rpm		127
P129 <sup>(2)(11)</sup>	Multispeed Reference 6	P133 to P134	1500 (1250) <sup>(11)</sup>	rpm		127
P130 <sup>(2)(11)</sup>	Multispeed Reference 7	P133 to P134	1800 (1500) <sup>(11)</sup>	rpm		127
P131 <sup>(2)(11)</sup>	Multispeed Reference 8	P133 to P134	1650 (1375) <sup>(11)</sup>	rpm		127
<b>Speed Limits</b>						
P132 <sup>(1)</sup>	Maximum Overspeed Level	(0 to 99) x P134 100=Disabled	10	%		128
P133 <sup>(2)(11)</sup>	Minimum Speed Reference	0 to (P134-1)	90 (75) <sup>(11)</sup>	rpm		128
P134 <sup>(2)(11)</sup>	Maximum Speed Reference	(P133+1) to (3.4xP402)	1800 (1500) <sup>(11)</sup>	rpm		128
<b>I/F Control</b>						
P135 <sup>(2)</sup>	Speed transition to I/F Control	0 to 90	18	rpm		129
P136 <sup>(1)</sup>	Current Reference (I*) for I/F Control	0=I <sub>mr</sub> 1=1.11x I <sub>mr</sub> 2=1.22x I <sub>mr</sub> 3=1.33x I <sub>mr</sub> 4=1.44x I <sub>mr</sub> 5=1.55x I <sub>mr</sub> 6= 1.66x I <sub>mr</sub> 7=1.77x I <sub>mr</sub> 8=1.88x I <sub>mr</sub> 9=2.00x I <sub>mr</sub>	1=1.11x I <sub>mr</sub>	-		129

(\*)P136 Has different functions for V/F and Vector control

Parameters	Function	Adjustable Range	Factory Setting	Unit	User's Setting	Page
<b>V/F Control</b>						
P136 <sup>(*)</sup>	Manual Boost Torque	0 to 9	1	-		130
P137	Automatic Torque Boost	0.00 to 1.00	0.00	-		131
P138	Slip Compensation	-10.0 to +10.0	0.0	%		131
P139	Output Current Filter	0.00 to 16.00	1.00	s		132
P140	Dwell Time at Start	0.0 to 10.0	0.0	s		132
P141	Dwell Speed at Start	0 to 300	90	rpm		132
<b>Adjustable V/F</b>						
P142 <sup>(*)</sup>	Maximum Output Voltage	0.0 to 100.0	100.0	%		133
P143 <sup>(*)</sup>	Intermediate Output Voltage	0.0 to 100.0	50.0	%		133
P144 <sup>(*)</sup>	Output Voltage at 3Hz	0.0 to 100.0	8.0	%		133
P145 <sup>(*)</sup>	Field Weakening Speed	P133 (>90) to P134	1800	rpm		133
P146 <sup>(*)</sup>	Intermediate Speed	90 to P145	900	rpm		133
<b>DC Link Voltage Regulation</b>						
P150 <sup>(*)</sup>	DC Link Voltage Regulation Mode	0=With Losses 1=Without Losses 2=Enable/Disable via DI3...DI8	1=Without Losses	-		134
P151 <sup>(6)(*)</sup>	DC Link Voltage Regulation Level (V/F control / Vector control with optimal braking)	339 to 400 (P296=0) 585 to 800 (P296=1) 616 to 800 (P296=2) 678 to 800 (P296=3) 739 to 800 (P296=4) 809 to 1000 (P296=5) 885 to 1000 (P296=6) 924 to 1000 (P296=7) 1063 to 1200 (P296=8)	400 800 800 800 800 1000 1000 1000 1200	V		134
P152	Proportional Gain	0.00 to 9.99	0.00	-		138
P153 <sup>(6)</sup>	Dynamic Braking Level	339 to 400 (P296=0) 585 to 800 (P296=1) 616 to 800 (P296=2) 678 to 800 (P296=3) 739 to 800 (P296=4) 809 to 1000 (P296=5) 885 to 1000 (P296=6) 924 to 1000 (P296=7) 1063 to 1200 (P296=8)	375 618 675 748 780 893 972 972 1174	V		138
P154	Dynamic Braking Resistor	0.0 to 500	0.0	Ω		139
P155	DB Resistor Power Rating	0.02 to 650	2.60	kW		139
<b>Overload Currents</b>						
P156 <sup>(2)(7)(12)</sup>	Overload Current 100% Speed	P157 to 1.3xP295 <sup>(12)</sup>	1.1xP401	A		140
P157 <sup>(2)(7)</sup>	Overload Current 50% Speed	P158 to P156	0.9xP401	A		140
P158 <sup>(2)(7)</sup>	Overload Current 5% Speed	(0.2xP295) to P157	0.5xP401	A		140
<b>Speed Regulator</b>						
P160 <sup>(*)</sup>	Optimization of the Speed Regulator	0=Speed 1=Torque	0=Speed	-		141
P161 <sup>(3)</sup>	Proportional Gain	0.0 to 63.9	7.4	-		142
P162 <sup>(3)</sup>	Integral Gain	0.000 to 9.999	0.023	-		142
P163	Local Speed Reference Offset	-999 to +999	0	-		144
P164	Remote Speed Reference Offset	-999 to +999	0	-		144

(\*) P151 has different function for V/F or Vector control.

**CFW-09 - QUICK PARAMETER REFERENCE**

Parameters	Function	Adjustable Range	Factory Setting	Unit	User's Setting	Page
<b>P165</b>	Speed Filter	0.012 to 1.000	0.012	s		144
<b>P166</b>	Speed Regulator Differential Gain	0.00 to 7.99	0.00 (without differential action)	-		144
<b>Current Regulator</b>						
<b>P167</b> <sup>(4)</sup>	Proportional Gain	0.00 to 1.99	0.5	-		144
<b>P168</b> <sup>(4)</sup>	Integral Gain	0.000 to 1.999	0.010	-		144
<b>P169</b> <sup>(1)(7)</sup>	Maximum Output Current (V/F Control)	(0.2xP295) to (1.8xP295)	1.5xP295	A		145
<b>P169</b> <sup>(1)(7)</sup>	Maximum Forward Torque Current (Vector Control)	0 to 180	125	%		145
<b>P170</b>	Maximum Reverse Torque Current (Vector Control)	0 to 180	125	%		145
<b>P171</b>	Maximum Forward Torque Current at Maximum Speed (P134)	0 to 180	125	%		146
<b>P172</b>	Maximum Reverse Torque Current at Maximum Speed (P134)	0 to 180	125	%		146
<b>P173</b>	Curve Type of the Max. Torque	0=Ramp 1=Step	0=Ramp	-		146
<b>Flux Regulator</b>						
<b>P175</b> <sup>(5)</sup>	Proportional Gain	0.0 to 31.9	2.0	-		147
<b>P176</b> <sup>(5)</sup>	Integral Gain	0.000 to 9.999	0.020	-		147
<b>P177</b>	Minimum Flux	0 to 120	0	%		147
<b>P178</b>	Nominal Flux	0 to 120	100	%		147
<b>P179</b>	Maximum Flux	0 to 120	120	%		147
<b>P180</b>	Field Weakenig Start Point	0 to 120	95	%		147
<b>P181</b> <sup>(1)</sup>	Magnetization Mode	0=General Enable 1=Start/Stop	0=General Enable	-		147
<b>CONFIGURATION PARAMETERS P200 to P399</b>						
<b>Generic Parameters</b>						
<b>P200</b>	Password	0=Off 1=On	1=On	-		148
<b>P201</b> <sup>(11)</sup>	Language Selection	0=Portuguese 1=English 2=Spanish 3=German	0, 1, 2, 3 <sup>(11)</sup>	-		148
<b>P202</b> <sup>(1)(2)(11)</sup>	Type of Control	0=V/F 60Hz 1=V/F 50Hz 2=V/F Adjustable 3=Sensorless Vector 4=Vector with Encoder 5=VVW (Voltage Vector WEG)	0 (1) <sup>(11)</sup>	-		148
<b>P203</b> <sup>(1)</sup>	Special Function Selection	0=None 1=PID Regulator	0=None	-		148
<b>P204</b> <sup>(1)(10)</sup>	Load/Save Parameters	0=Not Used 1=Not Used 2=Not Used 3=Reset P043 4=Reset P044 5=Loads Factory Default-60Hz 6=Loads Factory Default-50Hz	0=Not Used	-		149

(\*) P169 has different function for V/F or Vector control.

Parameters	Function	Adjustable Range	Factory Setting	Unit	User's Setting	Page
		7=Loads User Default 1 8=Loads User Default 2 9=Not Used 10=Save User Default 1 11=Save User Default 2				
P205	Display Default Selection	0=P005 (Motor Frequency) 1=P003 (Motor Current) 2=P002 (Motor Speed) 3=P007 (Motor Voltage) 4=P006 (Inverter Status) 5=P009 (Motor Torque) 6=P070 7=P040	2=P002	-		150
P206	Auto-Reset Time	0 to 255	0	s		151
P207	Reference Engineering Unit 1	32 to 127 (ASCII) A, B, ... , Y, Z 0, 1, ... , 9 #, \$, %, (, ), *, +, ...	114=r	-		151
P208 <sup>(2)(11)</sup>	Reference Scale Factor	1 to 18000	1800 (1500) <sup>(11)</sup>	-		151
P209 <sup>(1)</sup>	Motor Phase Loss Detection	0=Off 1=On	0=Off	-		152
P210	Decimal Point of the Speed Indication	0, 1, 2 or 3	0	-		152
P211 <sup>(1)</sup>	Zero Speed Disable	0=Off 1=On	0=Off	-		152
P212	Condition to Leave Zero Speed Disable	0=N* or N>P291 1=N*>P291	0=N* or N>P291	-		153
P213	Time Delay for Zero Speed Disable	0 to 999	0	s		153
P214 <sup>(1)(9)</sup>	Line Phase Loss Detection	0=Off 1=On	1=On	-		153
P215 <sup>(1)</sup>	Keypad Copy Function	0=Off 1=Inverter → Keypad 2=Keypad → Inverter	0=Off	-		153
P216	Reference Engineering Unit 2	32 to 127 (ASCII) A, B, ... , Y, Z 0, 1, ... , 9 #, \$, %, (, ), *, +, ...	112=p	-		155
P217	Reference Engineering Unit 3	32 to 127 (ASCII) A, B, ... , Y, Z 0, 1, ... , 9 #, \$, %, (, ), *, +, ...	109=m	-		155
P218	LCD Display Contrast Adjustment	0 to 150	127	-		155
<b>Local/Remote Definition</b>						
P220 <sup>(1)</sup>	Local/Remote Selection Source	0=Always Local 1=Always Remote 2=Keypad (Default Local) 3=Keypad (Default Remote) 4=DI2 to DI8 5=Serial (L)	2=Keypad (Default Local)	-		155

**CFW-09 - QUICK PARAMETER REFERENCE**

Parameters	Function	Adjustable Range	Factory Setting	Unit	User's Setting	Page
		6=Serial (R) 7=Fieldbus (L) 8=Fieldbus (R) 9=PLC (L) 10=PLC (R)				
<b>P221<sup>(1)</sup></b>	Local Speed Reference Selection	0=keypad 1=AI1 2=AI2 3=AI3 4=AI4 5=Add AI > 0 6=Add AI 7=EP 8=Multispeed 9=Serial 10=Fieldbus 11=PLC	0=Keypad	-		156
<b>P222<sup>(1)</sup></b>	Remote Speed Reference Selection	0=keypad 1=AI1 2=AI2 3=AI3 4=AI4 5=Add AI > 0 6=Add AI 7=EP 8=Multispeed 9=Serial 10=Fieldbus 11=PLC	1=AI1	-		156
<b>P223<sup>(1)(8)</sup></b>	Local FWD/REV Selection	0=Always Forward 1=Always Reverse 2=Keypad (Default FWD) 3=Keypad (Default REV) 4=DI2 5=Serial (Default FWD) 6=Serial (Default REV) 7=Fieldbus (Default FWD) 8=Fieldbus (Default REV) 9=Polarity AI4 10=PLC (FWD) 11=PLC (REV)	2=Keypad (Default FWD)	-		157
<b>P224<sup>(1)</sup></b>	Local Start/Stop Selection	0=[I] and [O] Keys 1=DIx 2=Serial 3=Fieldbus 4=PLC	0=[I] and [O] Keys	-		157
<b>P225<sup>(1)(8)</sup></b>	Local JOG Selection	0=Disable 1=Keypad 2=DI3 to DI8 3=Serial	1=Keypad	-		157

Parameters	Function	Adjustable Range	Factory Setting	Unit	User's Setting	Page
		4=Fieldbus 5=PLC				
P226 <sup>(1)(8)</sup>	Remote FWD/REV Selection	0=Always Forward 1=Always Reverse 2=Keypad (Default FWD) 3=Keypad (Default REV) 4=DI2 5=Serial (Default FWD) 6=Serial (Default REV) 7=Fieldbus (Default FWD) 8=Fieldbus (Default REV) 9=Polarity AI4 10=PLC (FWD) 11=PLC (REV)	4=DI2	-		158
P227 <sup>(1)</sup>	Remote Start/Stop Selection	0=[I] and [O] Keys 1=DIx 2=Serial 3=Fieldbus 4=PLC	1=DIx	-		158
P228 <sup>(1)(8)</sup>	Remote JOG Selection	0=Disable 1=Keypad 2=DI3 to DI8 3=Serial 4=Fieldbus 5=PLC	2=DI3 to DI8	-		158
<b>Stop Model Definition</b>						
P232 <sup>(1)</sup>	Stop Mode Selection	0=Ramp to Stop 1=Coast to Stop 2=Fast Stop	0=Ramp to Stop	-		164
<b>Analog Inputs</b>						
P233	Analog Inputs Dead Zone	0=Off 1=On	0=Off	-		164
P234	Analog Input AI1 Gain	0.000 to 9.999	1.000	-		165
P235 <sup>(1)</sup>	Analog Input AI1 Signal	0=(0 to 10)V / (0 to 20)mA 1=(4 to 20)mA 2=(10 to 0)V / (20 to 0)mA 3=(20 to 4)mA	0=(0 to 10)V / (0 to 20)mA	-		166
P236	Analog Input AI1 Offset	-100 to +100	0.0	%		166
P237 <sup>(1)(8)</sup>	Analog Input AI2 Function	0=P221/P222 1=N* without ramp 2=Maximum Torque Current 3=PID Process Variable	0=P221/P222	-		166
P238	Analog Input AI2 Gain	0.000 to 9.999	1.000	-		167
P239 <sup>(1)</sup>	Analog Input AI2 Signal	0=(0 to 10)V / (0 to 20)mA 1=(4 to 20)mA 2=(10 to 0)V / (20 to 0)mA 3=(20 to 4)mA	0=(0 to 10)V / (0 to 20)mA	-		167

**CFW-09 - QUICK PARAMETER REFERENCE**

Parameters	Function	Adjustable Range	Factory Setting	Unit	User's Setting	Page
<b>P240</b>	Analog Input AI2 Offset	-100 to +100	0.0	%		168
<b>P241<sup>(1)</sup></b>	Analog Input AI3 Function (Requires Optional I/O Expansion Board EBB)	0=P221/P222 1=Without ramp 2=Maximum Torque Current 3=PID Process Variable	0=P221/P222	-		168
<b>P242</b>	Analog Input AI3 Gain	0.000 to 9.999	1.000	-		169
<b>P243<sup>(1)</sup></b>	Analog Input AI3 Signal	0=(0 to 10)V / (0 to 20)mA 1=(4 to 20)mA 2=(10 to 0)V / (20 to 0)mA 3=(20 to 4)mA	0=(0 to 10)V / (0 to 20)mA	-		169
<b>P244</b>	Analog Input AI3 Offset	-100 to +100	0.0	%		169
<b>P245</b>	Analog Input AI4 Gain	0.000 to 9.999	1.000	-		169
<b>P246<sup>(1)</sup></b>	Analog Input AI4 Signal (Requires Optional I/O Expansion Board EBA)	0=(0 to 10)V / (0 to 20)mA 1=(4 to 20)mA 2=(10 to 0)V / (20 to 0)mA 3=(20 to 4)mA 4=(-10 to +10)V	0=(0 to 10)V / (0 to 20)mA	-		169
<b>P247</b>	Analog Input AI4 Offset	-100 to +100	0.0	%		170
<b>P248</b>	Input Filter AI2	00 to 16.0	0.0	s		170
<b>Analog Outputs</b>						
<b>P251</b>	Analog Output AO1 Function (CC9 or EBB board)	0=Speed Reference 1=Total Reference 2=Real Speed 3=Torque Current Reference (Vector) 4=Torque Current (Vector) 5=Output Current 6=PID Process Variable 7=Active Current (V/F) 8=Power (kW) 9=PID Setpoint 10=Positive Torque Current 11=Motor Torque 12=PLC 13= Dead Zone for Speed Indication	2=Real Speed	-		170
<b>P252</b>	Analog Output AO1 Gain	0.000 to 9.999	1.000	-		170
<b>P253</b>	Analog Output AO2 Function (CC9 or EBB board)	0=Speed Reference 1=Total Reference 2=Real Speed 3=Torque Current Reference (Vector) 4=Torque Current (Vector) 5=Output Current 6=PID Process Variable 7=Active Current (V/F) 8=Power (kW) 9=PID Setpoint 10=Positive Torque Current	5=Output Current	-		170

Parameters	Function	Adjustable Range	Factory Setting	Unit	User's Setting	Page
		11=Motor Torque 12=PLC 13=Dead Zone for Speed Indication				
<b>P254</b>	Analog Output AO2 Gain	0.000 to 9.999	1.000	-		170
<b>P255</b>	Analog Output AO3 Function (Requires Optional I/O Expansion Board EBA)	0=Speed Reference 1=Total Reference 2=Real Speed 3=Torque Current Reference (Vector) 4=Torque Current (Vector) 5=Output Current 6=PID Process Variable 7=Active Current(V/F) 8=Power (kW) 9=PID Setpoint 10= Positive Torque Current 11=Motor Torque 12=PLC 13=Not Used 49 signals for exclusive use of WEG	2=Real Speed	-		170
<b>P256</b>	Analog Output AO3 Gain	0.000 to 9.999	1.000	-		171
<b>P257</b>	Analog Output AO4 Function (Requires optional I/O Expansion Board EBA)	0=Speed Reference 1=Total Reference 2=Real Speed 3=Torque Current Reference (Vector) 4=Torque Current (Vector) 5=Output Current 6=PID Process Variable 7=Active Current (V/F) 8=Power (kW) 9=PID Setpoint 10= Positive Torque Current 11=Motor Torque 12=PLC 13=Not Used 49 signals for exclusive use of WEG	5=Output Current	-		171
<b>P258</b>	Analog Output AO4 Gain	0.000 to 9.999	1.000	-		171
<b>P259</b>	AO1 Value	0 to P134	1000	rpm		172
<b>Digital Inputs</b>						
<b>P263 <sup>(1)</sup></b>	Digital Input DI1 Function	0=Not Used 1=Start/Stop 2=General Enable 3=Fast Stop	1=Start/Stop	-		173
<b>P264 <sup>(1)</sup></b>	Digital Input DI2 Function	0=FWD/REV 1=Local/Remote	0=FWD/REV	-		173

**CFW-09 - QUICK PARAMETER REFERENCE**

Parameters	Function	Adjustable Range	Factory Setting	Unit	User's Setting	Page
		2=Not Used 3=Not Used 4=Not Used 5=Not Used 6=Not Used 7=Not Used 8=Reverse Run				
<b>P265</b> <sup>(1) (8)</sup>	Digital Input DI3 Function	0=Not Used 1=Local/ Remote 2=General Enable 3=JOG 4=No External Fault 5=Increase E.P. 6=Ramp 2 7=Not Used 8=Forward Run 9=Speed/Torque 10=JOG+ 11=JOG- 12=Reset 13=Fieldbus 14=Start (3 wire) 15=Man/Auto 16=Not used 17=Disables Flying Start 18=DC Voltage Regulator 19=Parameter Setting Disable 20=Load user 21=Timer (RL2) 22=Timer (RL3)	0=Not Used	-		173
<b>P266</b> <sup>(1)</sup>	Digital Input DI4 Function	0=Not used 1=Local/ Remote 2=General Enable 3=JOG 4=No external Fault 5=Decrease E.P. 6=Ramp 2 7=Multispeed (MS0) 8=Reverse Run 9= Speed/Torque 10=JOG+ 11=JOG- 12=Reset 13=Fieldbus 14=Stop (3 wire) 15=Man/Auto 16=Not used 17=Disables Flying Start	0=Not Used	-		173

Parameters	Function	Adjustable Range	Factory Setting	Unit	User's Setting	Page
		18=DC voltage regulator 19=Parameter Setting Disable 20=Load User 21=Timer (RL2) 22=Timer (RL3)				
<b>P267</b> <sup>(1)</sup>	Digital Input DI5 Function	0=Not Used 1=Local/ Remote 2=General Enable 3=JOG 4=No External Fault 5=Increase EP 6=Ramp 2 7=Multispeed (MS1) 8=Fast Stop 9= Speed/Torque 10=JOG+ 11=JOG- 12=Reset 13=Fieldbus 14=Start (3 wire) 15=Man/Auto 16=Not Used 17=Disables Flying Start 18=DC Voltage Regulator 19=Parameter Setting Disable 20=Load User 21=Timer (RL2) 22=Timer (RL3)	3=JOG	-		173
<b>P268</b> <sup>(1)</sup>	Digital Input DI6 Function	0=Not Used 1=Local/ Remote 2=General Enable 3=JOG 4=No External Fault 5=Decrease EP 6=Ramp 2 7=Multispeed (MS2) 8=Fast Stop 9= Speed/Torque 10=JOG+ 11=JOG- 12=Reset 13=Fieldbus 14=Stop (3 wire) 15=Man/Auto 16=Not Used 17=Disables flying start 18=DC voltage regulator	6=Ramp 2	-		174

**CFW-09 - QUICK PARAMETER REFERENCE**

Parameters	Function	Adjustable Range	Factory Setting	Unit	User's Setting	Page
		19=Parameter setting disable 20=Load user 21=Timer (RL2) 22=Timer (RL3)				
<b>P269</b> <sup>(1)</sup>	Digital Input DI7 Function (Requires optional I/O expansion board EBA or EBB)	0=Not Used 1=Local/ Remote 2=General Enable 3=JOG 4=No External Fault 5=Not Used 6=Ramp 2 7=Not Used 8=Fast Stop 9= Speed/Torque 10=JOG+ 11=JOG- 12=Reset 13=Fieldbus 14=Start (3 wire) 15=Man/Auto 16=Not Used 17=Disables Flying Start 18=DC Voltage Regulator 19=Parameter Setting Disable 20=Load User 21=Timer (RL2) 22=Timer (RL3)	0=Not used	-		174
<b>P270</b> <sup>(1)</sup>	Digital Input DI8 Function (Requires optional I/O expansion board EBA or EBB)	0=Not used 1=Local/Remote 2=General Enable 3=JOG 4=No External Fault 5=Not Used 6=Ramp 2 7=Not Used 8=Fast Stop 9= Speed/Torque 10=JOG+ 11=JOG- 12=Reset 13=Fieldbus 14=Stop (3 wire) 15=Man/Auto 16=Motor Thermistor 17=Disables Flying Start 18=DC Voltage Regulator 19=Parameter Setting	0=Not used	-		174

Parameters	Function	Adjustable Range	Factory Setting	Unit	User's Setting	Page
		Disable 20=Not Used 21=Timer (RL2) 22=Timer (RL3)				
<b>Digital Outputs</b>						
<b>P275</b> <sup>(1)</sup>	Digital Output DO1 Function (requires optional I/O expansion board EBA or EBB)	0=Not used 1=N* > Nx 2=N > Nx 3=N < Ny 4=N =N* 5=Zero Speed 6=Is > lx 7=Is < lx 8=Torque > Tx 9=Torque < Tx 10=Remote 11=Run 12=Ready 13=No Fault 14=No E00 15=No E01+E02+E03 16=No E04 17=No E05 18=(4 to 20)mA OK 19=Fieldbus 20=FWD 21=Proc.Var. > VPx 22=Proc. Var. < VPy 23=Ride-Through 24=Pre-charge OK 25=Fault 26=Enabled Hours > Hx 27=Not Used 28=Not Used 29=N > Nx and Nt > Nx 30=Brake (Actual Speed) 31=Brake (Total Reference) 32=Overweight 33=Slack Cable 34=Torque Polarity +/- 35=Torque Polarity -/+ 36=F > Fx _ 1 37=F > Fx _ 2 38=Set Point = Process Variable 39=No E32 40=Ready 2	0=Not Used	-		181

**CFW-09 - QUICK PARAMETER REFERENCE**

Parameters	Function	Adjustable Range	Factory Setting	Unit	User's Setting	Page
<b>P276</b> <sup>(1)</sup>	Digital Output DO2 Function (Requires optional I/O expansion board EBA or EBB)	0=Not Used 1=N* > Nx 2=N > Nx 3=N < Ny 4=N =N* 5=Zero Speed 6=Is > lx 7=Is < lx 8=Torque > Tx 9=Torque < Tx 10=Remote 11=Run 12=Ready 13=No Fault 14=No E00 15=No E01+E02+E03 16=No E04 17=No E05 18=(4 to 20)mA OK 19=Fieldbus 20=FWD 21=Proc.Var. > VPx 22=Proc. Var. < VPy 23=Ride-Through 24=Pre-charge OK 25=Fault 26=Enabled Hours > Hx 27=Not Used 28=Not Used 29=N > Nx and Nt > Nx 30=Brake (Actual Speed) 31=Brake (Total Reference) 32=Overweight 33=Slack Cable 34=Torque Polarity +/- 35=Torque Polarity -/+ 36=F > Fx _ 1 37=F > Fx _ 2 38=Set Point = Process Variable 39=No E32 40=Ready 2	0=Not used	-		181
<b>P277</b> <sup>(1)</sup>	Relay Output RL1 Function	0=Not Used 1=N* > Nx 2=N > Nx 3=N < Ny 4=N =N* 5=Zero Speed 6=Is > lx	13=No Fault	-		181

Parameters	Function	Adjustable Range	Factory Setting	Unit	User's Setting	Page
		7=Is < Ix 8=Torque > Tx 9=Torque < Tx 10=Remote 11=Run 12=Ready 13=No Fault 14=No E00 15=No E01+E02+E03 16=No E04 17=No E05 18=(4 to 20)mA OK 19=Fieldbus 20=FWD 21=Proc.Var. > VPx 22=Proc. Var. < VPy 23=Ride-Through 24=Pre-charge OK 25=Fault 26=Enabled Hours > Hx 27=PLC 28=Not Used 29=N > Nx and Nt > Nx 30=Brake (Actual Speed) 31=Brake (Total Reference) 32=Overweight 33=Slack Cable 34=Torque Polarity +/- 35=Torque Polarity -/+ 36=F > Fx _ 1 37=F > Fx _ 2 38=Set Point = Process Variable 39=No E32 40=Ready 2				
<b>P279</b> <sup>(1)</sup>	Relay Output RL2 Function	0=Not used 1=N* > Nx 2=N > Nx 3=N < Ny 4=N=N* 5=Zero Speed 6=Is > Ix 7=Is < Ix 8=Torque > Tx 9=Torque < Tx 10=Remote 11=Run 12=Ready 13=No Fault	2= N > Nx	-		181

**CFW-09 - QUICK PARAMETER REFERENCE**

Parameters	Function	Adjustable Range	Factory Setting	Unit	User's Setting	Page
		14=No E00 15=No E01+E02+E03 16=No E04 17=No E05 18=(4 to 20)mA OK 19=Fieldbus 20=FWD 21=Proc.Var. > VPx 22=Proc. Var. < VPy 23=Ride-Through 24=Pre-charge OK 25=Fault 26=Enabled Hours > Hx 27=PLC 28=Timer 29=N > Nx and Nt > Nx 30=Brake (Actual Speed) 31=Brake (Total Reference) 32=Overweight 33=Slack Cable 34=Torque Polarity +/- 35=Torque Polarity -/+ 36=F > Fx _ 1 37=F > Fx _ 2 38=Set Point = Process Variable 39=No E32 40=Ready 2				
<b>P280 <sup>(1)</sup></b>	Relay Output RL3 Function	0=Not used 1=N* > Nx 2=N > Nx 3=N < Ny 4=N=N* 5=Zero Speed 6=Is > lx 7=Is < lx 8=Torque > Tx 9=Torque < Tx 10=Remote 11=Run 12=Ready 13=No Fault 14=No E00 15=No E01+E02+E03 16=No E04 17=No E05 18=(4 to 20)mA OK 19=Fieldbus 20=FWD 21=Proc.Var. > VPx	1= N*>Nx	-		181

Parameters	Function	Adjustable Range	Factory Setting	Unit	User's Setting	Page
		22=Proc. Var. < VPy 23=Ride-Through 24=Pre-charge OK 25=Fault 26=Enabled Hours > Hx 27=PLC 28=Timer 29=N > Nx and Nt > Nx 30=Brake (Actual Speed) 31=Brake (Total Reference) 32=Overweight 33=Slack Cable 34=Torque Polarity +/- 35=Torque Polarity -/+ 36=F > Fx _ 1 37=F > Fx _ 2 38=Set Point = Process Variable 39=No E32 40=Ready 2				
<b>P283</b>	Time for RL2 ON	0.0 to 300	0.0	s		187
<b>P284</b>	Time for RL2 OFF	0.0 to 300	0.0	s		187
<b>P285</b>	Time for RL3 ON	0.0 to 300	0.0	s		187
<b>P286</b>	Time for RL3 OFF	0.0 to 300	0.0	s		187
<b>Nx, Ny, Ix, Zero Speed Zone, N=N* and Tx</b>						
<b>P287</b>	Hysteresis for Nx/Ny	0.0 to 5.0	1.0	%		194
<b>P288</b> <sup>(2)(11)</sup>	Nx Speed	0 to P134	120 (100) <sup>(11)</sup>	rpm		194
<b>P289</b> <sup>(2)(11)</sup>	Ny Speed	0 to P134	1800 (1500) <sup>(11)</sup>	rpm		194
<b>P290</b> <sup>(7)</sup>	Ix Current	(0 to 2.0)xP295	1.0xP295	A		194
<b>P291</b>	Zero Speed Zone	1 to 100	1	%		194
<b>P292</b>	N=N* Band	1 to 100	1	%		194
<b>P293</b>	Tx Torque	0 to 200	100	%		194
<b>P294</b>	Hours Hx	0 to 6553	4320	h		194
<b>Inverter Data</b>						
<b>P295</b> <sup>(1)</sup>	Inverter Rated Current	220-230V Models 3=6A      10=28.0A 4=7.0A    13=45.0A 6=10.0A   14=54.0A 7=13.0A   16=70.0A 8=16.0A   17=86.0A 9=24.0A   18=105.0A 19=130.0A	According to Inverter Model	-		195

**CFW-09 - QUICK PARAMETER REFERENCE**

Parameters	Function	Adjustable Range	Factory Setting	Unit	User's Setting	Page
		380-480V Models				
		0=3.6A   20=142.0A				
		1=4.0A   21=180.0A				
		2=5.5A   55=211.0A				
		5=9.0A   22=240.0A				
		7=13.0A   67=312.0A				
		8=16.0A   23=361A				
		9=24.0A   24=450.0A				
		11=30.0A   69=515.0A				
		12=38.0A   25=600.0A				
		13=45.0A   33=686A				
		15=60.0A   34=855A				
		16=70.0A   35=1140.0A				
		17=86.0A   36=1283 A				
		18=105.0A   37=1710 A				
		500-600V Models				
		39=2.9A   47=53.0A				
		40=4.2A   48=63.0A				
		4=7A   49=79.0A				
		6=10A   25=600A				
		41=12A   72=652A				
		42=14A   73=794A				
		43=22A   76=897A				
		44=27A   78=978A				
		45=32.0A   79=1191A				
		46=44.0A   81=1345A				
		500-690V Models				
		51=107A   60=315A				
		53=147A   62=343A				
		55=211A   63=418A				
		57=247A   65=472A				
		Models 500-690V				
		50=107A   68=492A				
		52=147A   70=580A				
		54=211A   71=646A				
		56=247A   74=813A				
		58=259A   75=869A				
		59=305A   77=969A				
		61=340A   80=1220A				
		64=428A				
		Special Models				
		38=2A   29=400A				
		66=33A   30=570A				
		26=200A   31=700A				
		27=230A   32=900A				
		28=320A				

Parameters	Function	Adjustable Range	Factory Setting	Unit	User's Setting	Page
<b>P296</b> <sup>(1)(11)</sup>	Inverter Rated Voltage (Rated Input Voltage)	0=220-230V 1=380V 2=400-415V 3=440-460V 4=480V 5=500-525V 6=550-575V 7=600V 8=660-690V	0=for models 220-230V 3= for models 380-480V 6=for models 500-600V and 500-690V 8= for models 660-690V <sup>(11)</sup>	-	Attention! See section 3.2.3 to do the voltage selection	196
<b>P297</b> <sup>(1)(2)</sup>	Switching Frequency	0=1.25 1=2.5 2=5.0 3=10.0	2=5.0	kHz		196
<b>DC Braking</b>						
<b>P300</b>	DC Braking Time	0.0 to 15.0	0.0	s		197
<b>P301</b>	DC Braking Start Speed	0 to 450	30	rpm		199
<b>P302</b>	DC Braking Voltage	0.0 to 10.0	2.0	%		199
<b>Skip Speed</b>						
<b>P303</b>	Skip Speed 1	P133 to P134	600	rpm		199
<b>P304</b>	Skip Speed 2	P133 to P134	900	rpm		199
<b>P305</b>	Skip Speed 3	P133 to P134	1200	rpm		199
<b>P306</b>	Skip Band	0 to 750	0	rpm		199
<b>Serial Communication</b>						
<b>P308</b> <sup>(1)</sup>	Inverter Address	1 to 30	1	-		199
<b>P309</b> <sup>(1)</sup>	Fieldbus	0=Disable 1=ProDP 2 I/O 2=ProDP 4 I/O 3=ProDP 6 I/O 4=DvNET 2 I/O 5=DvNET 4 I/O 6=DvNET 6 I/O	0=Disable	-		200
<b>P310</b>	STOP Detection in a Profibus Network	0=Off 1=On	0=Off			200
<b>P312</b> <sup>(1)</sup>	Type of Serial Protocol	0=WBUS Protocol 1=Modbus-RTU, 9600 bps, no parity 2=Modbus-RTU, 9600 bps, odd parity 3= Modbus-RTU, 9600 bps, even parity 4=Modbus-RTU, 19200 bps, no parity 5=Modbus-RTU, 19200 bps, odd parity 6=Modbus-RTU, 19200 bps, even parity 7=Modbus-RTU, 38400 bps, no parity	0=WEG Protocol	-		200

**CFW-09 - QUICK PARAMETER REFERENCE**

Parameters	Function	Adjustable Range	Factory Setting	Unit	User's Setting	Page
		8=Modbus-RTU, 38400 bps, odd parity 9=Modbus-RTU, 38400 bps, even parity				
<b>P313</b> <sup>(1)</sup>	Type of disabling by E28/E29/E30	0=Disable by Start/Stop 1=Disable by General Enable 2=Not Used 3=Changes to LOCAL 1 4=Changes to LOCAL 2	0=Disable by Start/Stop	-		201
<b>P314</b> <sup>(1)</sup>	Time for Serial Watchdog Action	0.0=Disabled 0.1 to 999.0	0.0=Disabled	s		201
<b>P318</b>	Watchdog detection for the PLC board	0=Off 1=On	1=On			201
<b>Flying Start/Ride-Through</b>						
<b>P320</b> <sup>(1)</sup>	Flying Start/Ride-Through	0=Inactive 1=Flying Start 2=Flying Start/Ride-Through 3=Ride-Through	0=Inactive	-		202
<b>P321</b> <sup>(6)</sup>	Ud Line Loss Level	178 to 282 (P296=0) 307 to 487 (P296=1) 324 to 513 (P296=2) 356 to 564 (P296=3) 388 to 616 (P296=4) 425 to 674 (P296=5) 466 to 737 (P296=6) 486 to 770 (P296=7) 559 to 885 (P296=8)	252 436 459 505 550 602 660 689 792	V		202
<b>P322</b> <sup>(6)</sup>	Ud Ride-Through	178 to 282 (P296=0) 307 to 487 (P296=1) 324 to 513 (P296=2) 356 to 564 (P296=3) 388 to 616 (P296=4) 425 to 674 (P296=5) 466 to 737 (P296=6) 486 to 770 (P296=7) 559 to 885 (P296=8)	245 423 446 490 535 588 644 672 773	V		203
<b>P323</b> <sup>(6)</sup>	Ud Line Recover Level	178 to 282 (P296=0) 307 to 487 (P296=1) 324 to 513 (P296=2) 356 to 564 (P296=3) 388 to 616 (P296=4) 425 to 674 (P296=5) 466 to 737 (P296=6) 486 to 770 (P296=7) 559 to 885 (P296=8)	267 461 486 534 583 638 699 729 838	V		203
<b>P325</b>	Ride-Through Proportional Gain	0.0 to 63.9	22.8	-		204
<b>P326</b>	Ride-Through Integral Gain	0.000 to 9.999	0.128	-		204
<b>P331</b>	Voltage Ramp	0.2 to 60.0	2.0	s		205
<b>P332</b>	Dead Time	0.1 to 10.0	1.0	s		205

Parameters	Function	Adjustable Range	Factory Setting	Unit	User's Setting	Page
<b>PARAMETERS FOR CRANE APPLICATIONS AND FOR MASTER/SLAVE FUNCTION - P351 to P368</b>						
<b>Logic for the Mechanical Braking Operation</b>						
P351 <sup>(1)</sup>	Delay for E33	0.0 to 99.9	99.9	s		207
P352 <sup>(1)</sup>	Delay for E34	0 to 999	999	s		207
P353 <sup>(1)</sup>	Delay for N<Nx - Brake activation	0.0 to 20.0	0.0	s		207
P354 <sup>(1)</sup>	Delay for resetting the Integrator of the Speed Regulator	0.0 to 10.0	2.0	s		207
P355 <sup>(1)</sup>	Delay for accepting new "Start/Stop" commands	0.0 to 10.0	1.0	s		207
P356 <sup>(1)</sup>	Delay for ramp enable	0.0 to 10.0	0.0	s		208
<b>Indication of the Torque Current Polarity</b>						
P357 <sup>(1)</sup>	Torque Current (Iq) Filter	0.00 to 9.99	0.00	s		208
P358 <sup>(1)</sup>	Torque Current (Iq) Hysteresis	0.00 to 9.99	2.00	%		208
<b>Parameters for Load Detection</b>						
P361 <sup>(1)</sup>	Load Detection	0=Off 1=On	0=Off	-		208
P362 <sup>(1)</sup>	Stabilization Speed	0 to P134	90 rpm	-		208
P363 <sup>(1)</sup>	Stabilization Time	0.1 to 10.0	0.1	s		209
P364 <sup>(1)</sup>	Slack Cable Time	0.0 to 60.0	0.0	s		209
P365 <sup>(1)</sup>	Slack Cable Level	0.0 to 1.3 x P295	0.1 x P295	-		209
P366 <sup>(1)</sup>	Lightweight Level	0.0 to 1.3 x P295	0.3 x P295	-		209
P367 <sup>(1)</sup>	Overweight Level	0.0 to 1.8 x P295	1.1 x P295	-		209
P368 <sup>(1)</sup>	Speed Reference Gain	1.000 to 2.000	1.000	-		209
<b>Fx</b>						
P369 <sup>(2)(11)</sup>	Frequency Fx	0.0 to 300.0	4.0	Hz		209
P370	Hysteresis for Fx	0.0 to 15.0	2.0	Hz		212
<b>DC Braking</b>						
P371	DC Braking Time at Start	0.0 to 15.0	0.0	s		212
P372	DC Braking Current Level	0.0 to 90.0	40.0	%		212
<b>VVW Control</b>						
P398 <sup>(1)</sup>	Slip Compensation during Regeneration	0=Off 1=On	1=On	-		212
P399 <sup>(1)(2)</sup>	Motor Rated Efficiency	50.0 to 99.9	According to the motor rated power factor (P404)	%		212
<b>MOTOR PARAMETERS P400 to P499</b>						
<b>Motor Nameplate Data</b>						
P400 <sup>(1)(6)</sup>	Motor Rated Voltage	0 to 690	P296	V		213
P401 <sup>(1)(12)</sup>	Motor Rated Current	(0.0 to 1.30)xP295 <sup>(12)</sup>	1.0xP295	A		213
P402 <sup>(1)(2)(11)</sup>	Motor Rated RPM	0 to 18000 (P202=0, 1, 2 and 5) 0 to 7200 (P202=3 and 4)	1750 (1458) <sup>(11)</sup>	rpm		213
P403 <sup>(1)(11)</sup>	Motor Rated Frequency	0 to 300 (P202=0,1,2 and 5) 30 to 120 (P202 = 3 and 4)	60 (50) <sup>(11)</sup>	Hz		213
P404 <sup>(1)</sup>	Motor Rated HP	0=0.33 HP/0.25 kW 1=0.50 HP/0.37 kW 2=0.75 HP/0.55 kW 3=1.0 HP/0.75 kW 4=1.5 HP/1.1 kW	4=1.5 HP/1.1 kW	-		213

**CFW-09 - QUICK PARAMETER REFERENCE**

Parameters	Function	Adjustable Range	Factory Setting	Unit	User's Setting	Page
		5=2.0 HP/1.5 kW 6=3.0 HP/2.2 kW 7=4.0 HP/3.0 kW 8=5.0 HP/3.7 kW 9=5.5 HP/4.0 kW 10=6.0 HP/4.5 kW 11=7.5 HP/5.5 kW 12=10.0 HP/7.5 kW 13=12.5 HP/9.0 kW 14=15.0 HP/11.0 kW 15=20.0 HP/15.0 kW 16=25.0 HP/18.5 kW 17=30.0 HP/22.0 kW 18=40.0 HP/30.0 kW 19=50.0 HP/37.0 kW 20=60.0 HP/45.0 kW 21=75.0 HP/55.0 kW 22=100.0 HP/75.0 kW 23=125.0 HP/90.0 kW 24=150.0 HP/110.0 kW 25=175.0 HP/130.0 kW 26=180.0 HP/132.0 kW 27=200.0 HP/150.0 kW 28=220.0 HP/160.0 kW 29=250.0 HP/185.0 kW 30=270.0 HP/200.0 kW 31=300.0 HP/220.0 kW 32=350.0 HP/260.0 kW 33=380.0 HP/280.0 kW 34=400.0 HP/300.0 kW 35=430.0 HP/315.0kW 36=440.0 HP/330.0kW 37=450.0 HP/335.0 kW 38=475.0 HP/355.0 kW 39=500.0 HP/375.0 kW 40=540.0 HP/400.0kW 41=600.0 HP/450.0 kW 42=620.0 HP/460.0kW 43=670.0 HP/500.0kW 44=700.0 HP/525.0 kW 45=760.0 HP/570.0 kW 46=800.0 HP/600.0 kW 47=850.0 HP/630.0kW 48=900.0 HP/670.0 kW 49=1100.0 HP/820.0 kW 50=1600.0 HP/1190.0 kW				
<b>P405</b> <sup>(1)</sup>	Encoder PPR	250 to 9999	1024	ppr		214
<b>P406</b> <sup>(1)</sup>	Motor Ventilation Type	0=Self Ventilated 1=Separate Ventilation	0=Self Ventilated	-		214

Parameters	Function	Adjustable Range	Factory Setting	Unit	User's Setting	Page
		2=Optimal Flux 3=Increased Protection				
P407 <sup>(1) (2)</sup>	Motor Rated Power Factor	0.50 to 0.99	According to the motor rated power (P404)			215
<b>Measured Parameters</b>						
P408 <sup>(1)</sup>	Self-Tuning	0=No 1=No Rotation 2=Run for $I_{mr}$ 3=Run for $T_M$ 4=Estimate $T_M$	0=No	-		215
P409 <sup>(1)</sup>	Motor Stator Resistance (Rs)	0.000 to 77.95	0.000	$\Omega$		216
P410	Motor Magnetizing Current ( $I_{mr}$ )	(0.0 to 1.25)xP295	0	A		217
P411 <sup>(1)</sup>	Motor Flux Leakage Inductance ( $\sigma LS$ )	0.00 to 99.99	0	mH		217
P412	L <sub>R</sub> /R <sub>R</sub> Constant (Rotor Time Constant (Tr))	0.000 to 9.999	0	s		217
P413 <sup>(1)</sup>	T <sub>M</sub> Constant (Mechanical Time Constant)	0.00 to 99.99	0	s		218
<b>SPECIAL FUNCTION PARAMETERS P520 to P536</b>						
<b>PID Regulator</b>						
P520	PID Proportional Gain	0.000 to 7.999	1.000	-		222
P521	PID Integral Gain	0.000 to 7.999	0.043	-		222
P522	PID Differential Gain	0.000 to 3.499	0.000	-		222
P523	PID Ramp Time	0.0 to 999	3.0	s		222
P524 <sup>(1)</sup>	Selection of PID Feedback	0=AI2 (P237) 1=AI3 (P241)	0=AI2 (P237)	-		222
P525	PID Setpoint	0.0 to 100.0	0.0	%		223
P526	Process Variable Filter	0.0 to 16.0	0.1	s		223
P527	PID Action	0=Direct 1=Reverse	0=Direct	-		223
P528	Proc. Var. Scale Factor	1 to 9999	1000	-		224
P529	Decimal Point of Proc. Var.	0, 1, 2 or 3	1			224
P530	Engineering Unit of Proc. Var. 1	32 to 127 (ASCII) A, B, ..., Y, Z 0, 1, ..., 9 #, \$, %, (, ), *, +, ...	37=%	-		225
P531	Engineering Unit of Proc. Var. 2	32 to 127 (ASCII) A, B, ..., Y, Z 0, 1, ..., 9 #, \$, %, (, ), *, +, ...	32=blank	-		225
P532	Engineering Unit of Proc. Var. 3	32 to 127 (ASCII) A, B, ..., Y, Z 0, 1, ..., 9 #, \$, %, (, ), *, +, ...	32=blank	-		225
P533	Value of Proc. Var. X	0.0 to 100	90.0	%		225
P534	Value of Proc. Var. Y	0.0 to 100	10.0	%		225
P535	Wake Up Band	0 to 100	0	%		226
P536 <sup>(1)</sup>	Automatic Setting of P525	0=Active 1=Inactive	0=Active	-		226

Parameters	Function	Adjustable Range	Factory Setting	Unit	User's Setting	Page
P537	Hysteresis for Set point = Process Variable	1 to 100	1	%		226
P538	Hysteresis for VPx/VPy	0.0 to 5.0	1.0	%		226

Notes presented on Quick Parameter Description:

- (1) Parameter can be changed only with the inverter disabled (motor stopped)
- (2) Values may change as a function of the "Motor Parameters".
- (3) Values may change as a function of P413 (Tm Constant - obtained during Self-tuning).
- (4) Values may change as a function of P409 and P411 (obtained during Self-tuning).
- (5) Values may change as a function of P412 (Tr Constant - obtained during Self-tuning).
- (6) Values may change as a function of P296.
- (7) Values may change as a function of P295.
- (8) Values may change as a function of P203.
- (9) Values may change as a function of P320.
- (10) User's Standard (for new inverters) = without parameter.
- (11) The inverter will be delivered with settings according to the market, considering the HMI language, V/F 50 Hz or 60 Hz and the required voltage. The reset of the standard factory setting may change the parameters related to the frequency (50 Hz/60 Hz). Values within parenthesis mean the factory setting for 50 Hz.
- (12) The maximum value of P156 and P401 is 1.8xP295 for model 4.2A/500-600V and 1.6xP295 for models 7A and 54A/220-230V; 2.9A and 7A/500-600V; 107A, 147A and 247A/500-690V; 100A, 127A and 340A/660-690V.

Parameters that affect others when set	Parameters that are affected and modified automatically	Condition where it occurs	
		During the oriented start-up	During normal operation
P203	P223, P225, P226, P228, P237, P265	NO	YES
P295	P156, P157, P158, P169 (V/f), P290, P365, P366, P367	NO	YES
P296	P151, P153, P321, P322, P323	YES	YES
	P400	YES	NO
P320	P214	NO	YES
P401	P156, P157, P158	YES	NO
	P297	YES	NO
P402	P122, P123, P124, P125, P126, P127, P128, P129, P130, P131, P133, P134, P135, P208, P288, P289	YES	YES
P403	P369, P402	YES	NO
P404	P399, P407	YES	YES
P406	P156, P157, P158	YES	NO

**Table 1 - Interdependence among parameters: Parameters that change the settings of others when modified X Parameters that are automatically modified as a function of a parameter setting (during start-up and/or normal operation).**

## II. Fault Messages

Display	Description	Page
<b>E00</b>	Output Overcurrent/Short-Circuit	227
<b>E01</b>	DC Link Overvoltage	227
<b>E02</b>	DC Link Undervoltage	227
<b>E03</b>	Power Supply Undervoltage/Phase Loss	228
<b>E04<sup>(*)</sup></b>	Inverter Overtemperature/Pre-charge Circuit Failure	228
<b>E05</b>	Output Overload (lxt Function)	228
<b>E06</b>	External Fault	228
<b>E07</b>	Encoder Fault Valid for P202=4 (Vector with Encoder)	228
<b>E08</b>	CPU Error (watchdog)	228
<b>E09</b>	Program Memory Error	228
<b>E10</b>	Error in the Copy Function	228
<b>E11</b>	Output Ground Fault	228
<b>E12</b>	Dynamic Braking Resistor Overload	229
<b>E13</b>	Motor or Encoder with Inverted Wires (Self-Tuning) (Valid for P202=4)	229
<b>E15</b>	Motor Phase Loss	229
<b>E17</b>	Overspeed Fault	229
<b>E24</b>	Programming Error	229
<b>E28 to E30</b>	Serial communication error	229
<b>E31</b>	Keypad Connection Fault	229
<b>E32</b>	Motor Overtemperature	229
<b>E33</b>	Speed without control	229
<b>E34</b>	Long period at torque limitation	229
<b>E41</b>	Self-Diagnosis Fault	229
<b>E70</b>	Internal DC Supply Undervoltage	230
<b>E71</b>	PLC Watchdog Error	230

(\*) E04 can be "Pre-charge Circuit Failure" only in the following models:  
 $\geq 86\text{A}/380\text{-}480\text{V}$ ,  $\geq 70\text{A}/220\text{-}230\text{V}$ ,  $\geq 44\text{A}/500\text{-}600\text{V}$  and for all 500-690V and 660-690V models. E04 can also occur when signal with inverted polarity is applied at analog inputs AI1/AI2. The E04 fault message can also occur in the models up to 130A/ 20-230V, 142A/380-480V and 63A/500-600V when the temperature at the heatsink is lower than -10°C.

## III. Other Messages

Display	Description
<b>rdy</b>	Inverter is Ready to be Enabled
<b>run</b>	Inverter is Enabled
<b>Sub</b>	Power Supply Voltage is Too Low for the Inverter Operation (Undervoltage)
<b>dCbr</b>	Inverter in DC Braking Mode. (See P300)

## SAFETY NOTICES

This Manual contains all necessary information for the correct installation and operation of the CFW-09 Variable Frequency Drive. The CFW-09 Instruction Manual has been written for qualified personnel with suitable training or technical qualifications to operate this type of equipment.

### 1.1 SAFETY NOTICES IN THE MANUAL

The following Safety Notices will be used in this Manual:



#### **DANGER!**

If the recommended Safety Instructions are not strictly observed, it can lead to serious or fatal injuries of personnel and/or equipment damage.



#### **ATTENTION!**

Failure to observe the recommended Safety Procedures can lead to material damage.



#### **NOTE!**

The content of this Manual supplies important information for the correct understanding of operation and proper performance of the equipment.

### 1.2 SAFETY NOTICES ON THE PRODUCT

The following symbols may be attached to the product, serving as Safety Notice:



#### **High Voltages**



**Components are sensitive to electrostatic discharge. Do not touch them without following proper grounding procedures.**



#### **Mandatory connection to ground protection (PE)**



#### **Shield connection to ground**

### 1.3 PRELIMINARY RECOMMENDATIONS



#### **DANGER!**

Only qualified personnel should plan or implement the installation, startup, operation and maintenance of this equipment. Personnel must review this entire Manual before attempting to install, operate or troubleshoot the CFW-09.

These personnel must follow all safety instructions included in this Manual and/or defined by local regulations.

Failure to comply with these instructions may result in personnel injury and/or equipment damage.

**NOTE!**

In this Manual, qualified personnel are defined as people that are trained to:

1. Install, ground, power up and operate the CFW-09 according to this Manual and the local required safety procedures;
2. Use of safety equipment according to the local regulations;
3. Administer Cardio Pulmonary Resuscitation (CPR) and First Aid.

**DANGER!**

Always disconnect the supply voltage before touching any electrical component inside the inverter.

Many components are charged with high voltages, even after the incoming AC power supply has been disconnected or switched OFF. Wait at least 10 minutes for the total discharge of the power capacitors.

Always connect the frame of the equipment to the ground (PE) at the suitable connection point.

**ATTENTION!**

All electronic boards have components that are sensitive to electrostatic discharges. Never touch any of the electrical components or connectors without following proper grounding procedures. If necessary to do so, touch the properly grounded metallic frame or use a suitable ground strap.

**Do not apply High Voltage (High Pot) Test on the Inverter!  
If this test is necessary, contact the Manufacturer.**

**NOTE!**

Inverters can interfere with other electronic equipment. In order to reduce this interference, adopt the measures recommended in Section 3 "Installation".

**NOTE!**

Read this entire Manual carefully and completely before installing or operating the CFW-09.

### GENERAL INFORMATION

This chapter defines the contents and purpose of this manual and describes the main characteristics of the CFW-09 frequency inverter. Identification of the CFW-09, receiving and storage requirements are also provided.

#### 2.1 ABOUT THIS MANUAL

This Manual is divided into 9 Chapters, providing information to the user on how to receive, install, start-up and operate the CFW-09:

- Chapter 1: Safety Notices;
- Chapter 2: General Information and Receiving the CFW09;
- Chapter 3: Information about the CFW09 physical installation, electrical connection (power and control circuit) and installation of optional devices;
- Chapter 4: Keypad (HMI) Operation (Human-Machine Interface - keyboard-display);
- Chapter 5: Start-up (Step-by-step);
- Chapter 6: Detailed Programming Parameters Description;
- Chapter 7: Diagnostics, troubleshooting, cleaning instructions and preventive maintenance;
- Chapter 8: Technical description of CFW09 optional devices and accessories;
- Chapter 9: Technical specifications (electrical and mechanical)

This Manual provides information for the correct use of the CFW-09. The CFW-09 is very flexible and allows for the operation in many different modes as described in this manual.

As the CFW-09 can be applied in several ways, it is impossible to describe here all of the application possibilities. WEG does not accept any responsibility when the CFW-09 is not used according to this Manual.

No part of this Manual may be reproduced in any form, without the written permission of WEG.

#### 2.2 SOFTWARE VERSION

It is important to note the Software Version installed in the Version CFW-09, since it defines the functions and the programming parameters of the inverter. This Manual refers to the Software version indicated on the inside cover. For example, the Version 1.0X applies to versions 1.00 to 1.09, where "X" is a variable that will change due to minor software revisions. The operation of the CFW-09 with these software revisions are still covered by this version of the Manual.

The Software Version can be read in the Parameter P023.

#### 2.3 ABOUT THE CFW-09

The CFW-09 is a high performance Variable Frequency Drive that permits the control of speed and torque of a three-phase AC induction motor. The technological advantage of the CFW-09 is due to the "Vectrue" technology that provides the following benefits:

- Programmable scalar (volts/Hz) or vector control with the same product;
- Vector Control can be programmed for "Sensorless" (that means that standard motors can be controlled without encoder feedback), or "Closed Loop" (with an encoder attached to the motor shaft);

- ☑ The sensorless vector control permits high torques and quick response, even at very low speeds and during the starting of the motor;
- ☑ The “Optimal Braking” function allows controlled motor braking without using a Dynamic Braking (DB) resistor.
- ☑ “Self-tuning” auto-tune function with vector control, permitting automatic setting of the control regulators and control parameters by means of the automatic identification of the motor and the load parameters.

Technical specifications for each model of CFW09 are described in section 9. The block diagram below gives a general view of the CFW-09:

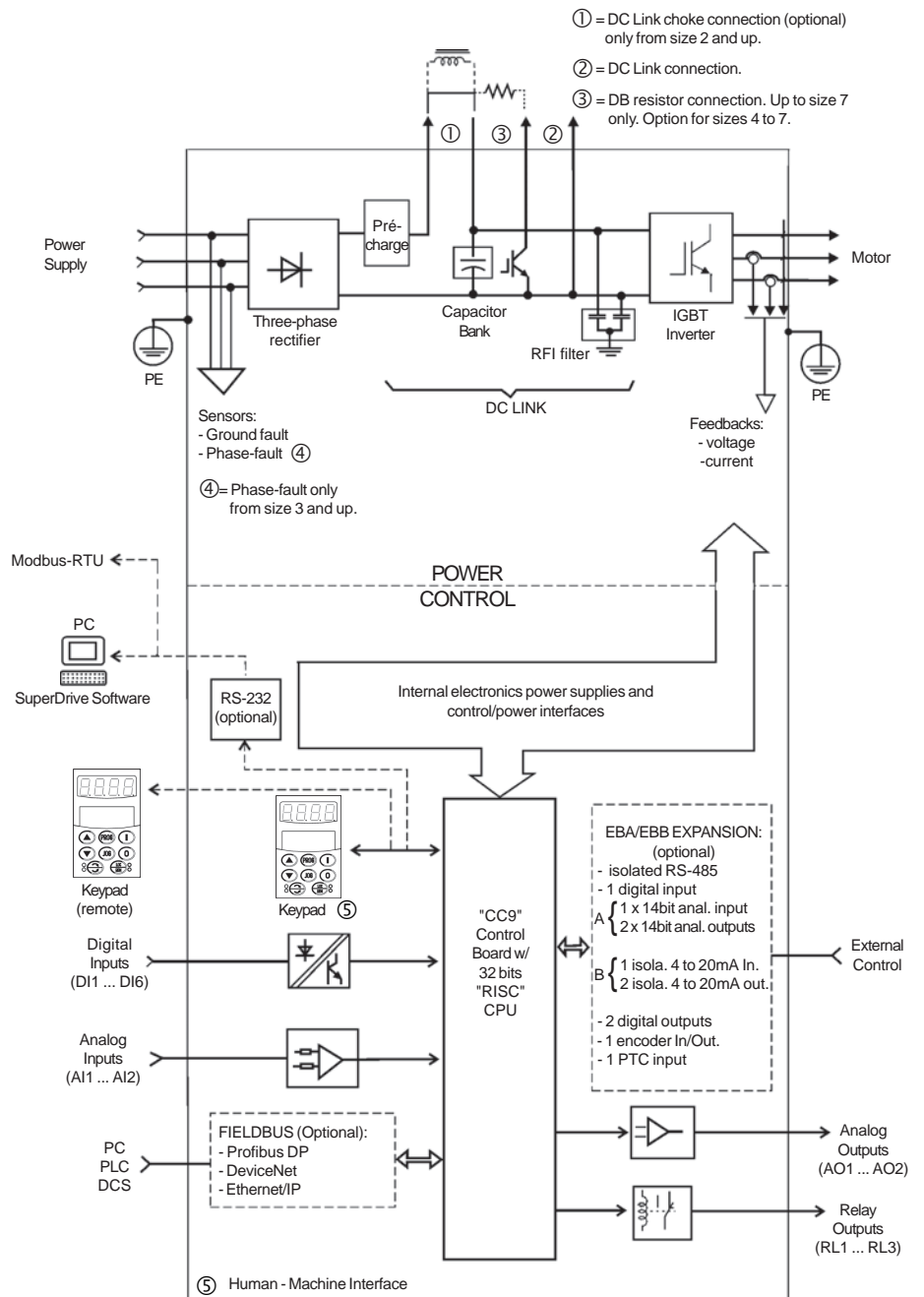
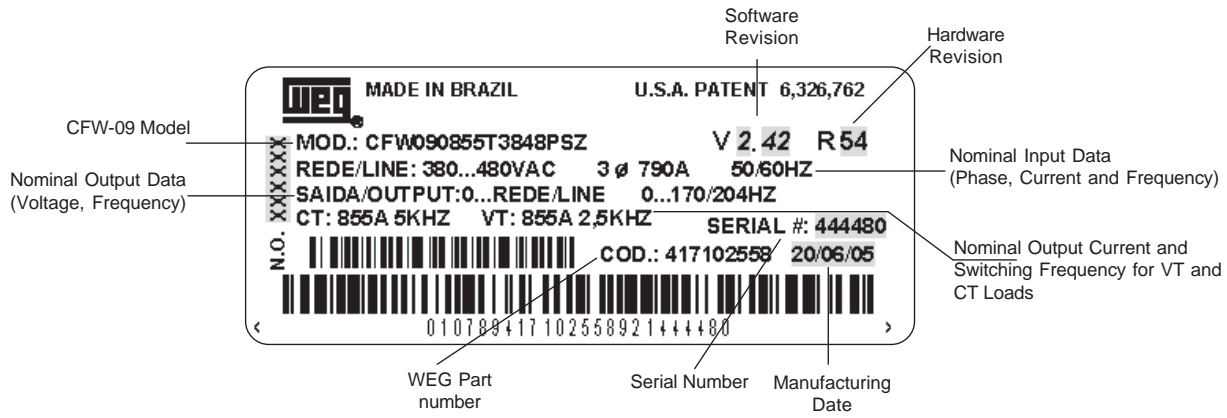

Figure 2.1 - CFW09 Block Diagram.

2.4 CFW-09 IDENTIFICATION LABEL AND CODE NUMBER



Location of the CFW-09 Nameplate:

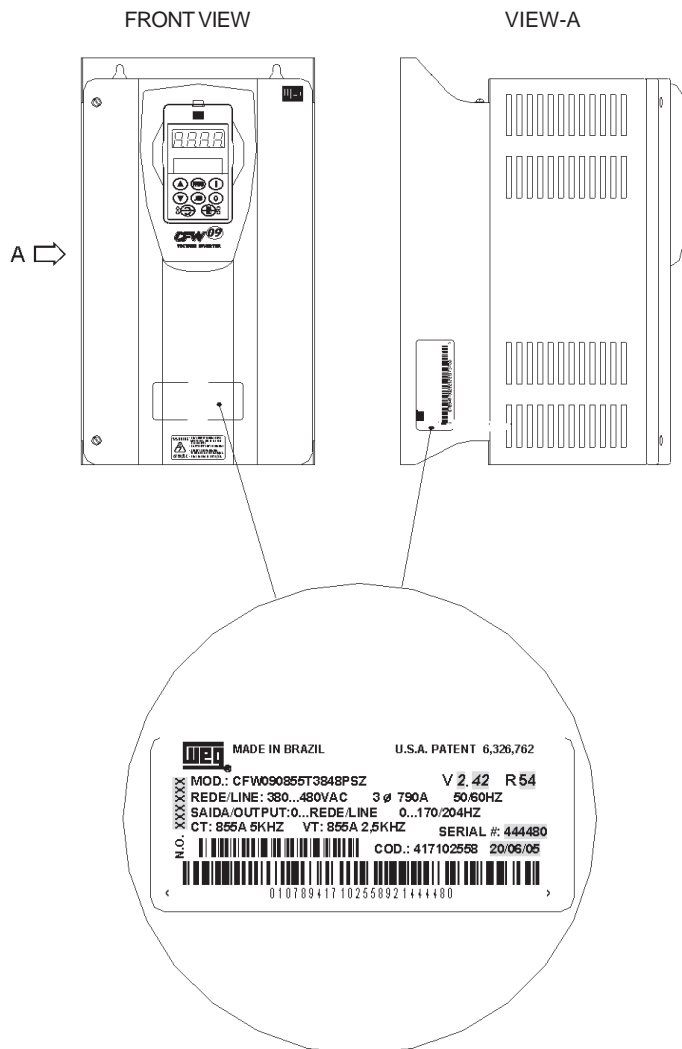

Figure 2.2 - CFW09 Identification.

## HOW TO SPECIFY THE CFW-09 MODEL:

CFW-09	0016	T	3848	E	O	--	--	--	--	Z			
WEG Series 09 Frequency Inverter	Output rated current - constant torque CT:	Three-phase power supply:	Power supply voltage:	Manual language:	Options:	Enclosure degree of protection:	Keypad (HMI):	Braking:	Expansion Boards:	Fieldbus Communication Boards:	Special Hardware:	Special Software:	End of Code (See note)
	<b>220-230V:</b> 0006=6A 0007=7A 0010=10A 0013=13A 0016=16A 0024=24A 0028=28A 0045=45A 0054=54A 0070=70A 0086=86A 0105=105A 0130=130A  <b>500-600V:</b> 0002=2.9A 0004=4.2A 0007=7A 0010=10A 0012=12A 0014=14A 0022=22A 0027=27A 0032=32A 0044=44A 0053=53A 0063=63A 0079=79A  <b>380-480V:</b> 0003=3.6A 0004=4A 0005=5.5A 0013=13A 0016=16A 0024=24A 0030=30A 0038=38A 0045=45A 0060=60A 0070=70A 0086=86A 0105=105A 0180=180A 0211=211A 0240=240A 0312=312A 0361=361A 0450=450A 0515=515A 0600=600A		3848 = 380-480V 2223 = 220-230V 5060 = 500-600V 5069 = 500-690V 6669 = 660-690V	P= Portuguese E=English S=Spanish	S= standard O= with options (see note)	Blank= Standard N4=NEMA 4 IP56 (See chapter 8)	Blank= Standard IL= Keypad only LED display SI= without keypad (See note)	Blank= Standard RB=Regenerative Converter (Active Front end unit). DB= Dynamic Braking (See chapter 8)	Blank= Standard A1= EBA Board Complete B1= EBB Board Complete C1= EBC1 Board Complete Refer to Chapter 8 for other Configurations P1=PLC 1.01 Board P2=PLC2.00 Board (See chapter 8)	Blank= Standard DN= DeviceNet PD= Profibus DP DD=DeviceNet Profile EN=Ethernet/IP	Blank= Standard HN= Without DC link inductor (only valid for 500-690V and 660-690V models) HD= DC link supply (refer to chapter 8) HC, HV= DC Link inductor (See chapter 8) (See note)	Blank= Standard S1 to Sn = Special Software Version SF= Metasys N2 Protocol SQ= Special version for DeviceNet Drive Profile Kit (indicate option DD for the Fieldbus Communication Board)	



**Note:**

- For rated output current specification of variable torque (VT), see chapter 9.
- The rated output current indicated for the models 500-690V are only valid for 500V to 600V supply.
- For rated output current specification (CT and VT) of the models with supply voltage higher than 600V, see chapter 9.



**Note:**

- The option field (S or O) defines if the CFW-09 is a standard version or if it is equipped with any optional devices. If the standard version is required, the code ends here. The model code number always has the letter Z at the end. For example: CFW090045T2223ESZ = Standard 45A CFW-09 inverter - three phase input at 220-230V, with the Manual in English.
- If the CFW-09 is equipped with any optional devices, you must fill out the fields in accordance to the optional devices desired in the correct sequence up to the last optional device desired, then the model code number is completed with the letter Z. Thus, for instance, if a product of the example above is required with a EBA expansion board, indicate: CFW090045T2223EOA1Z = 45A CFW-09 inverter – three-phase input at 220-230V, with the manual in English and with the optional EBA.01 board.

The standard product is defined as described here:

**Degree of protection:**

NEMA 1/IP20: 3.6A to 240A/380-480V models and all 220-230V and 500-600V models.

Protected chassis / IP20: 361A to 600A/380-480V models and all 500-690V and 660-690V models.

**Human Machine Interface:**

HMI-CFW09-LCD (with LED and LCD displays)

**Braking:**

DB Transistor for DB Resistor braking incorporated in the following models:

6A to 45A/220-230V

3.6A to 30A/380-480V

2.9A to 14A/500-600V

**DC Link:**

The DC link choke is included in the standard product for 44A, 53A, 63A and 79A/500-600V, all models 500-690V and 660-690V models.

DB Transistor can be incorporated as an option in the following models:

54A to 130A/220-230V

38A to 142A/380-480V

22A to 79A/500-600V

Models 180A to 600A/380-480V, 107A to 472A/500-690V and 100A to 428A/660-690V, do not have the capability to use an internal DB Transistor. In this case, use the external DB Transistor option (see item 8.10.3 - Dynamic Braking Module - DBW-01 and DBW-02).



**NOTE!**

It is necessary to connect an external braking resistor regardless if the DB Transistor is built in, optional built in or an external module (DBW).

## 2.5 RECEIVING AND STORAGE

The CFW-09 is supplied in cardboard boxes up to size 3 (see Item 9) and for models above, the packing will be with wood pallet and wood box.

The outside of the packing container has a nameplate that is identical to that on the CFW-09. Please check if the nameplate data matches the ordered ones.

The boxes up to size 7 must be placed and opened on a table (sizes above 3 with the help of two persons).

Open the box, remove the cardboard or expanded polystyrene protection.

The boxes of sizes above 7 must be opened on the floor. Open the wood box, remove the expanded polystyrene protection. The CFW-09 must be handled with hoist.

Check if:

CFW-09 nameplate data matches the purchase order;

The equipment has not been damaged during transport.

If any problem is detected, contact the carrier immediately.

If the CFW-09 is not to be installed immediately, store it in a clean and dry room (Storage temperatures between -25°C and 60°C). Cover it to prevent dust, dirt or other contamination of the drive.



**ATTENTION!**

If the inverter is stored for long periods, we recommend to power it up once a year during 1 hour. For 220-230V and 380-480V models apply supply voltage of approx. 220Vac, three-phase or single-phase input, 50 or 60 Hz, without connecting motor at output. After this energization, wait 24 hours before installing it. For 500-600V, 500-690V and 660-690V models use the same procedure applying a voltage between 300 and 330Vac to the inverter input.

## INSTALLATION

This chapter describes the procedures for the electrical and mechanical installation of the CFW-09.

These guidelines must be followed for proper CFW-09 operation.

### 3.1 MECHANICAL INSTALLATION

#### 3.1.1 Environment Conditions

The location of the CFW-09 installation is an important factor to assure good performance and high product reliability.

For proper installation of the inverter, we make the following recommendations:

- ☑ Avoid direct exposure to sunlight, rain, high moisture and sea air.
- ☑ Avoid exposure to gases or explosive or corrosive liquids;
- ☑ Avoid exposure to excessive vibration, dust, oil or any (conductive particles or materials).

#### Allowed environmental conditions:

- ☑ Temperature: 0°C to 40°C (32°F to 104°F) - nominal conditions.  
From 40°C to 55°C (32°F to 131°F) - with 2% current derating for each 1°C (1.8°F) degree above 40°C (104°F).
- ☑ Relative Air Humidity: 5% to 90%, non-condensing.
- ☑ Maximum Altitude: 1000m (3,300 ft) – nominal conditions.  
From 1000m to 4000m (3,300ft to 13,200 ft) – with 1% current reduction for each 100m (330 ft) above 1000m (3,300 ft).
- ☑ Pollution Degree: 2 (according to EN50178 and UL508C) (It is not allowed the presence of water, condensation or conductive dust/ particles in the air).

#### 3.1.2 Dimensional of CFW-09

External dimensions and mounting holes are according to Figure 3.1 and Table 3.1.

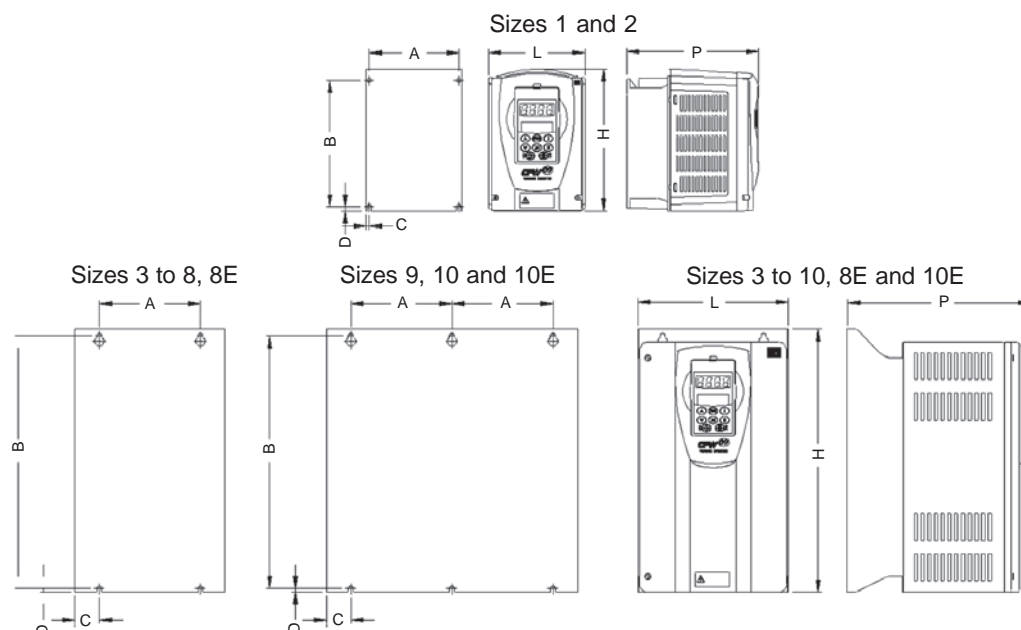

**Figure 3.1 - Mounting Dimensional Drawings of CFW-09**

Model	Height H mm (in)	Width L mm (in)	Depth P mm (in)	A mm (in)	B mm (in)	C mm (in)	D mm (in)	Mounting Screw mm (in)	Weight Kg (lb)	Degree of Protection
Size 1	210 (8.27)	143 (5.63)	196 (7.72)	121 (4.76)	180 (7.09)	11 (0.43)	9.5 (0.37)	M5 (3/16)	3.5 (7.7)	NEMA1/ IP20
Size 2	290 (11.42)	182 (7.16)	196 (7.72)	161 (6.34)	260 (10.24)	10.5 (0.41)	9.5 (0.37)	M5 (3/16)	6.0 (13.2)	
Size 3	390 (15.35)	223 (8.78)	274 (10.79)	150 (5.90)	375 (14.76)	36.5 (1.44)	5 (0.20)	M6 (1/4)	19.0 (41.9)	
Size 4	475 (18.70)	250 (9.84)	274 (10.79)	150 (5.90)	450 (17.72)	50 (1.97)	10 (0.39)	M6 (1/4)	22.5 (49.6)	
Size 5	550 (21.65)	335 (13.19)	274 (10.79)	200 (7.87)	525 (20.67)	67.5 (2.66)	10 (0.39)	M8 (5/16)	41 (90.4)	
Size 6	675 (26.57)	335 (13.19)	300 (11.77)	200 (7.87)	650 (25.59)	67.5 (2.66)	10 (0.39)	M8 (5/16)	55 (121.3)	
Size 7	835 (32.87)	335 (13.19)	300 (12.20)	200 (7.87)	810 (31.89)	67.5 (2.66)	10 (0.39)	M8 (5/16)	70 (154.3)	
Size 8	975 (38.38)	410 (16.14)	370 (14.57)	175 (10.83)	950 (37.40)	67.5 (2.66)	10 (0.39)	M10 (3/8)	100 (220.5)	
Size 8E	1145 (45.08)	410 (16.14 )	370 (14.57)	275 (10.83)	1120 (44.09)	67.5 (2.66)	10 (0.39)	M10 (3/8)	115 (253)	
Size 9	1020 (39.37)	688 (27.56)	492 (19.33)	275 (10.83)	985 (37.99)	69 (2.95)	15 (0.59)	M10 (3/8)	216 (476.2)	
Size 10	1185 (46.65)	700 (27.56)	492 (19.33)	275 (10.83)	1150 (45.27)	69 (2.95)	15 (0.59)	M10 (3/8)	259 (571)	
Size 10E	1185 (46.65)	700 (27.56)	582 (22.91)	275 (10.83)	1150 (45.27)	69 (2.95)	15 (0.59)	M10 (3/8)	310 (682)	

**Table 3.1 - Installation Data – Refer to Section 9.1**

**3.1.3 Mounting Specifications**

For installing the CFW09, leave at least the minimum free spaces around the inverter according to Figure 3.2 . The dimensions of these free spaces are described on Table 3.2.

Install the inverter in the vertical position according to the following recommendations:

- 1) Install the inverter on a flat surface.
- 2) Do not install heat sensitive components immediately above the inverter.
- 3) For the inverters 45A to 130A/220-230V, 30A to 600A/380-480V, 22A to 32A/ 500-600V, 44A to 79A/500-600V, 107A to 472A/500-690V and 100A to 428A/ 660-690V:  
 - First partially tighten the bolts on the surface, then install the inverter and screw-down the bolts.
- 4) For inverters 6A to 28A/220-230V, 3.6A to 24A/380-480V and 2.9A to 14A/ 500-600V:  
 - Install the 2 bottom mounting bolts first, rest the inverter on the base and then mount the 2 top bolts.



**ATTENTION!**

When inverters are installed side by side, maintain the minimum recommended distance B. When inverters are installed top and bottom, maintain the minimum recommended distance A + C and deflect the hot air coming from inverter below.



**ATTENTION!**

Provide independent conduits for signal, control and power conductors (Refer to Section 3.2: Electrical Installation).

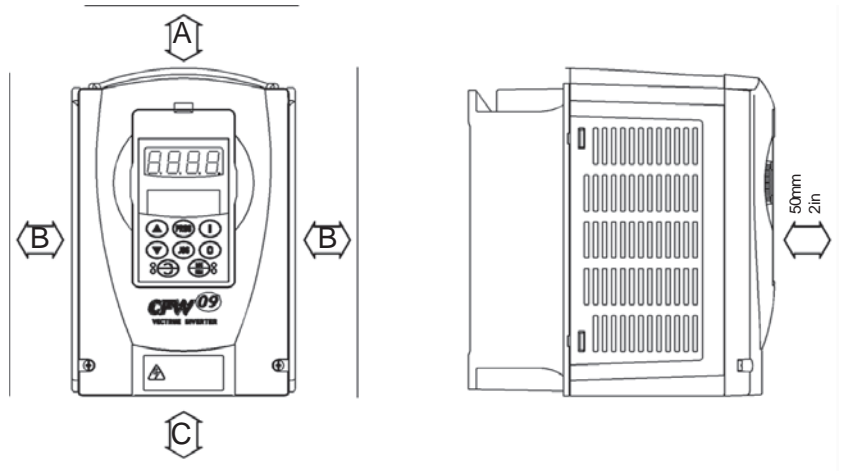

Figure 3.2 - Free Space for Cooling

Model	A	B	C
CFW-09	mm (in)	mm (in)	mm (in)
6A to 28A/220-230V	40	30	50
3.6A to 24A/380-480V	(1.57)	(1.18)	(2)
2.9A to 14A/500-600V			
45A to 130A/220-230V	100	40	130
30A to 142A/380-480V	(4)	(1.57)	(5.12)
22A to 79A/500-600V			
180A to 361A/380-480V	150	55 (2,17)	250
450A to 600A/380-480V	(6)	80	(10)
107A to 472A/500-690V		(3.15)	
100A to 428A/660-690V			

Table 3.2 - Recommended free spaces

3.1.3.1 Mounting Inside a Panel

When inverters are installed in panels or closed metallic boxes, adequate cooling is required to ensure that the temperature around the inverter will not exceed the maximum allowed temperature. See Dissipated Power in Section 9.1.

For reference, table 3.3 shows the cooling airflow for each inverter model.

**Inverter Cooling Method:** Internal fan, flow direction from the bottom to the top.

CFW-09 Inverter Model	Size	CFM	l/s	m <sup>3</sup> /min
6A to 13A/220-230V 3.6A to 9A/380-480V	1	19	9	0,5
2.9A to 14A/500-600V 16A to 28A/220-230V 13A to 24A/380-480V	2	32	15	0,9
45A/220-230V 30A/380-480V	3	70	33	2,0
54A/220-230V 38A and 45A/380-480V 22A to 32A/500-600V	4	89	42	2,5
70A and 86A/220-230V 60A and 70A/380-480V	5	117	55	3,3
105A and 130A/220-230V 86A and 105A/380-480V	6	138	65	3,9
44A to 79A/500-600V 142A/380-480V	7	286	135	8,1
180A to 240A/380-480V 107A to 211A/500-690V 100A to 179A/660-690V	8 8E 8E	265	125	7,5
312A and 361A/380-480V	9	852	402	24,1
450A to 600A/380-480V 247A to 472A/500-690V 225A to 428A/660-690V	10 10E 10E	795	375	22,5

**Table 3.3** - Cooling Air Flow requirements

3.1.3.2 Mounting on Surface

Figure 3.3 shows the installation of the CFW-09 on a mounting plate.

a) Sizes 1 and 2

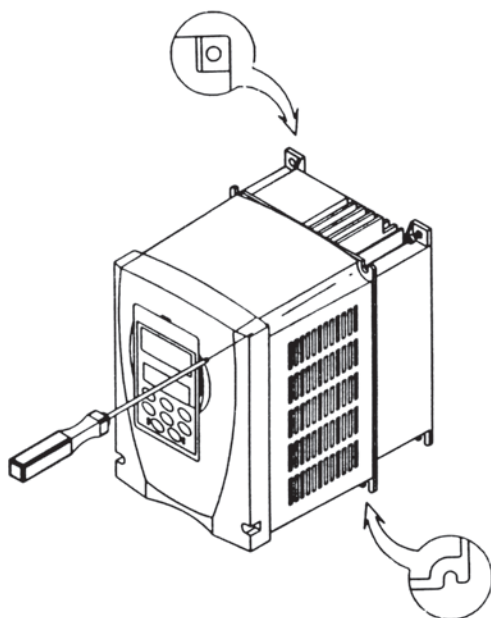

b) Sizes 3 to 8

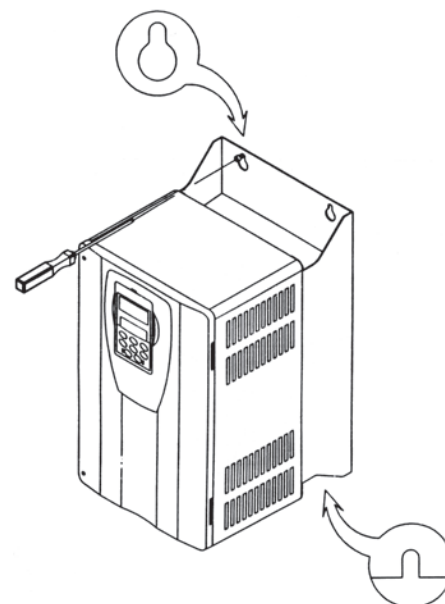

**Figure 3.3 a) b)** - Mounting procedure for the CFW-09 on a surface

c) Sizes 9 and 10

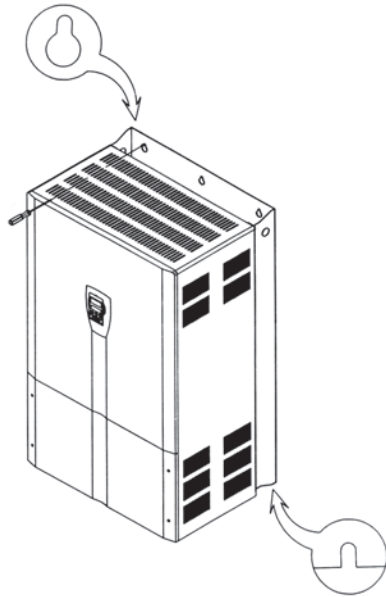

d) Positioning (for all Sizes)

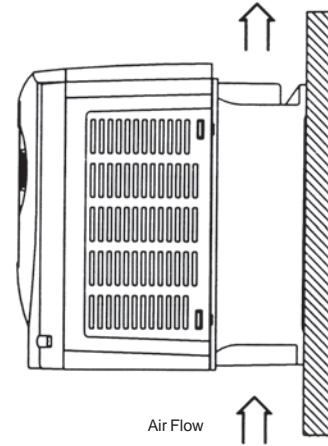

Figure 3.3 c) d) - Mounting procedure for the CFW-09 on a surface

### 3.1.3.3 Mounting with the Heatsink through a Surface

The CFW-09 can also be installed with the heatsink through the mounting plate, as shown in Figure 3.4. In this case, see installation drawings shown in Figure 3.4 c) and maintain the distances indicated in table 3.4.



**NOTE!**

When installing the heatsink through the mounting surface, according to Figure 3.4, the degree of protection behind this surface is NEMA 1 / IP20. NEMA1 rating does not protect against dust and water.

## CHAPTER 3 - INSTALLATION

a) Sizes 1 and 2

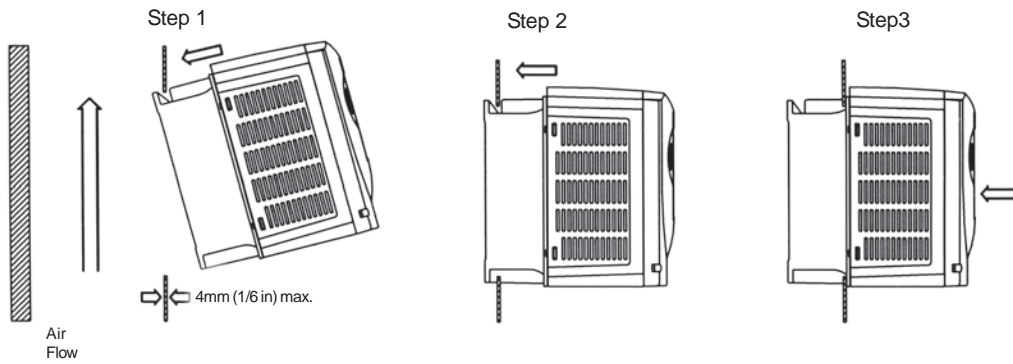

b) Sizes 3 to 8E

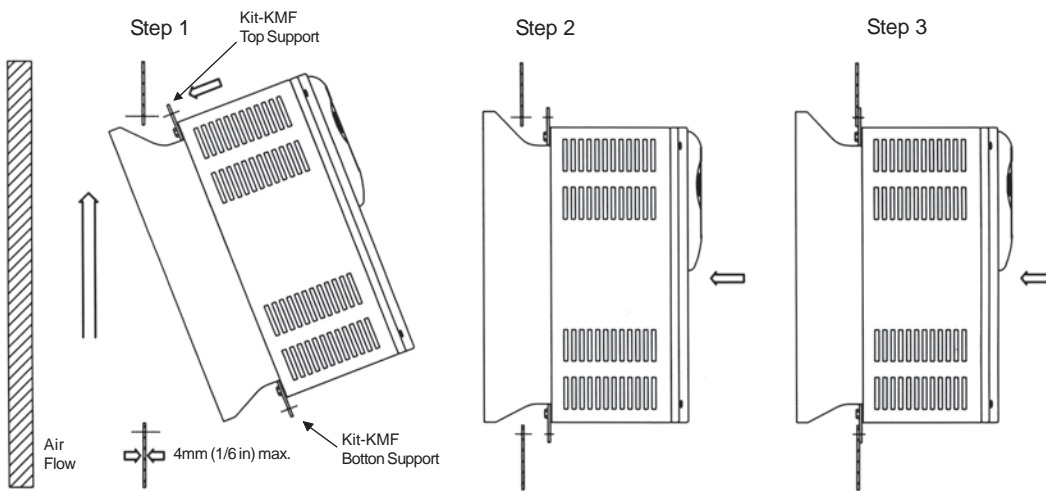

c) Cutout Dimensions (Refer to Table 3.4)

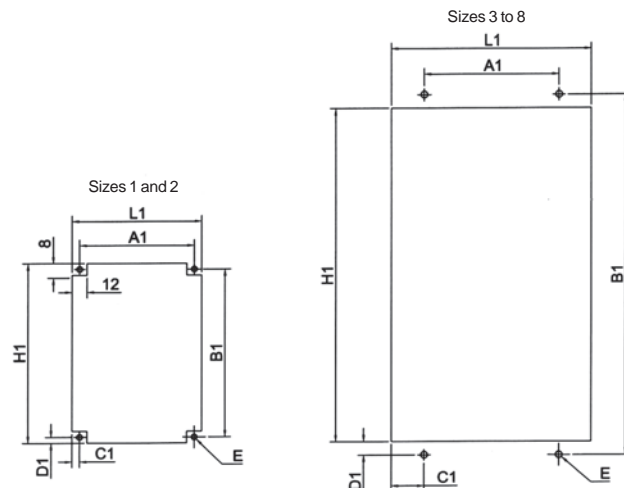

Figure 3.4 a) to c) - Mounting procedure for the CFW-09 with the heatsink through the mounting surface

CFW-09 Size	L1 mm (in)	H1 mm (in)	A1 mm (in)	B1 mm (in)	C1 mm (in)	D1 mm (in)	E mim. mm (in)	Kit KMF* Through Surface Mounting Item n°
Size 1	139 (5.47)	196 (7.72)	127 (5.00)	191 (7.52)	6 (0.24)	2.5 (0.10)	6 (0.24)	-----
Size 2	178 (7.00)	276 (10.87)	167 (6.57)	271 (10.67)	6 (0.24)	2.5 (0.10)	6 (0.24)	-----
Size 3	225 (7.00)	372 (14.64)	150 (6.57)	400 (15.75)	37.5 (1.44)	14 (0.59)	8 (0.31)	417102514
Size 4	252 (9.92)	452 (17.79)	150 (5.91)	480 (18.90)	51 (1.97)	14 (0.59)	8 (0.31)	417102515
Size 5	337 (13.27)	527 (20.75)	200 (7.87)	555 (21.85)	68.5 (2.70)	14 (0.59)	10 (0.35)	417102516
Size 6	13.27 (13.27)	652 (25.67)	200 (7.87)	680 (26.77)	68.5 (2.70)	14 (0.59)	10 (0.39)	417102517
Size 7	337 (13.27)	812 (31.97)	200 (7.87)	840 (33.07)	68.5 (2.70)	14 (0.59)	10 (0.39)	417102518
Size 8	412 (16.22)	952 (37.48)	275 (10.38)	980 (38.58)	68.5 (2.70)	14 (0.59)	10 (0.39)	417102519
Size 8E	412 (16.22)	1122 (44.17)	275 (10.83)	1150 (45.27)	68.5 (2.70)	14 (0.59)	10 (0.39)	

\*Note: The Through Surface Mounting kit (kit-KMF) is a set of supports for the CFW-09 as shown on Figure 3.4 b).

Table 3.4 - Cutout dimensions and kits for CFW-09 though surface mounting

### 3.1.4 Keypad (HMI) and Cover Removal

a) Sizes 1 and 2

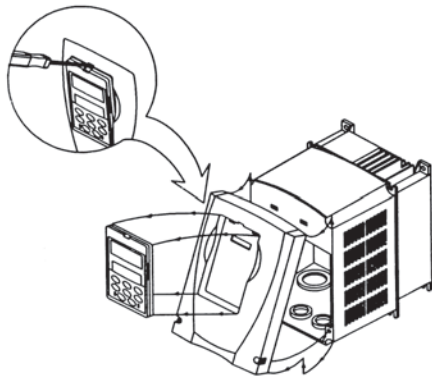

b) Sizes 3 to 8, 8E

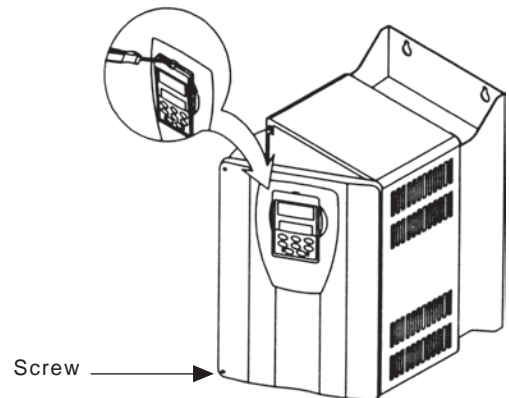

Figure 3.5 a) b) – Keypad (HMI) and cover removal procedure

c) Sizes 9 and 10, 10E

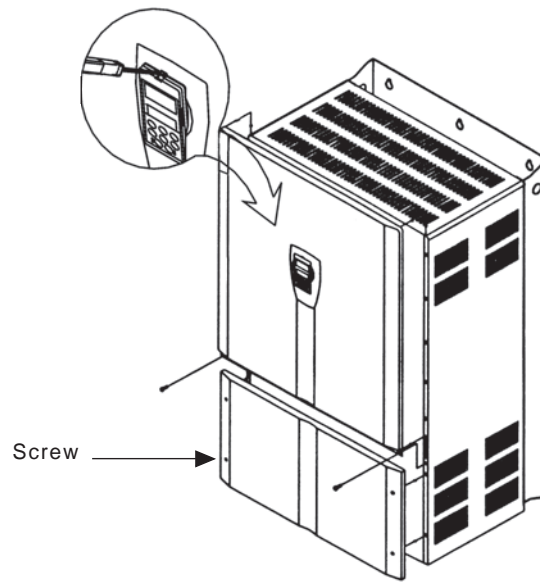

Figure 3.5 c) – Keypad (HMI) and cover removal procedure

## 3.2 ELECTRICAL INSTALLATION



### **DANGER!**

The information below will be a guide to achieve a proper installation. Follow also all applicable local standards for electrical installations.



### **DANGER!**

Be sure that the AC input power is disconnected before making any terminal connection.



### **DANGER!**

The CFW-09 frequency inverter cannot be used as an emergency stop device. Provide another devices for this function.

### 3.2.1 Power/Grounding Terminals

The power connection terminals can be of different sizes and configurations, depending on the inverter model as shown in Figure 3.6.

Terminals:

- R, S, T : AC supply line. Models up to 10A at 220-230V can be operated with two phases (single-phase operation) without current derating. In this case the AC supply can be connected to any 2 of the 3 input terminals.
- U, V, W: Motor connection.
- UD: Negative pole of the DC link circuit.
- BR: Dynamic Braking resistor connection.
- +UD: Positive pole of the DC link circuit.
- DCR: Connection to the external DC link choke (optional).
- PE: Ground Safety

a) Size 1 models

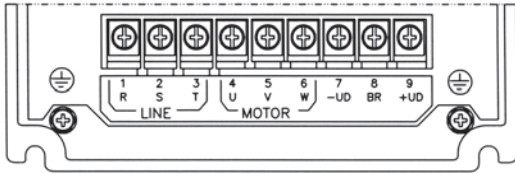

b) Size 2 models

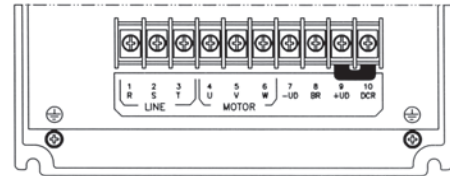

c) Size 3, 4 and 5 models

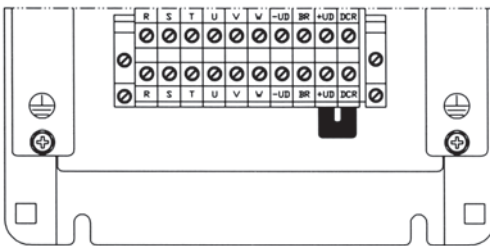

d) Size 6 and 7 (220-230V and 380-480V models)

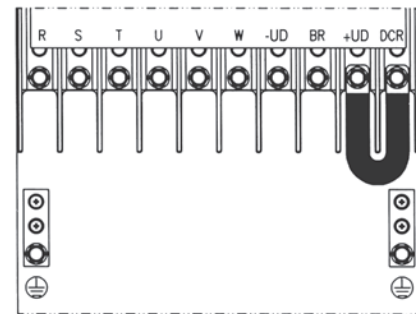

e) Size 7 (500-600V models)

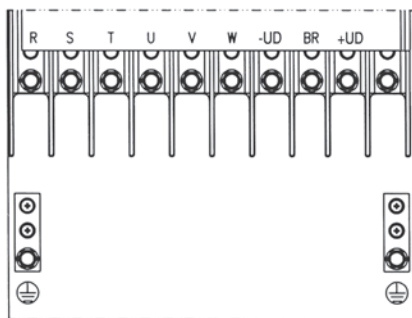

f) Size 8 (380-480V models)

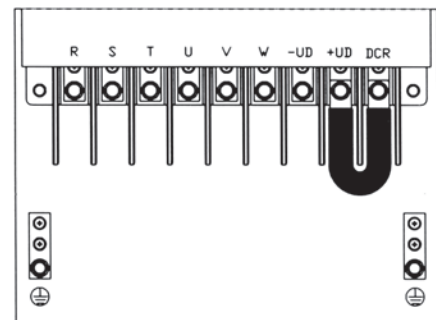

g) Size 9 and 10 (380-480V models)

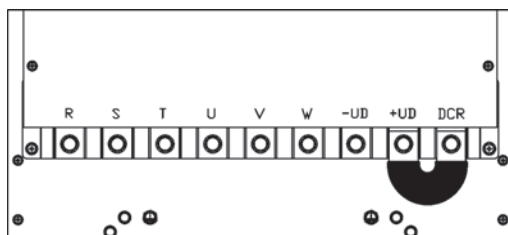

h) Size 8E (500-690V and 660-690V models)

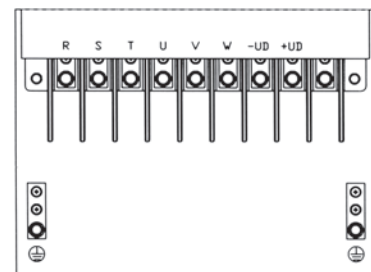
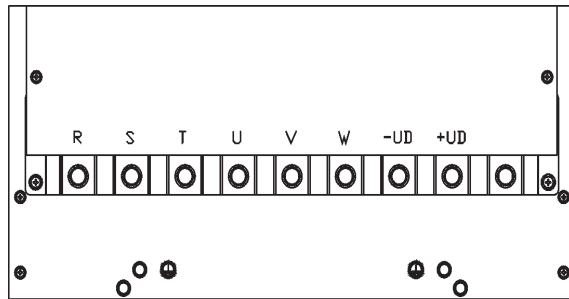

Figure 3.6 a) to h) - Power Terminals.

i) Size10E (500-690V and 660-690V models)

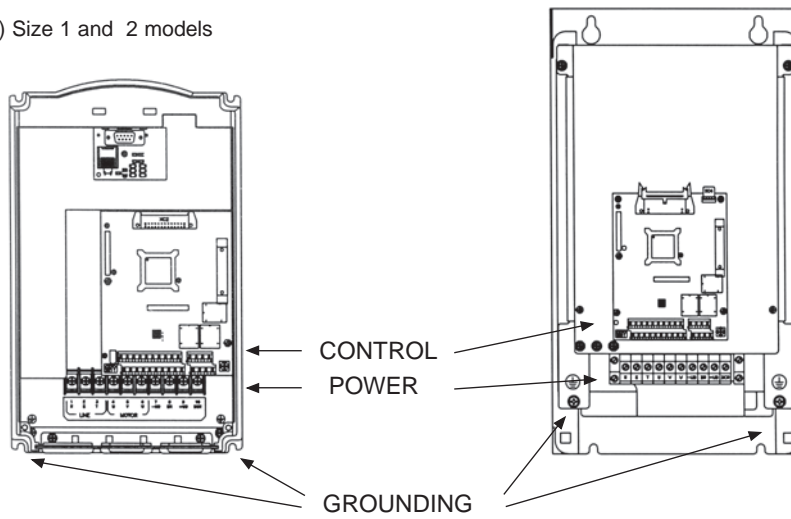

**Figure 3.6 i) - Power Terminals.**

### 3.2.2 Location of the Power/ Grounding/Control Connections

b) Size 3, 4 and 5 models

a) Size 1 and 2 models



Note: No voltage selection needed for these models

**Figure 3.7 a) b) - Location of the Power/Grounding/Control Connections and Rated Voltage**

c) Size 6 and 7 models

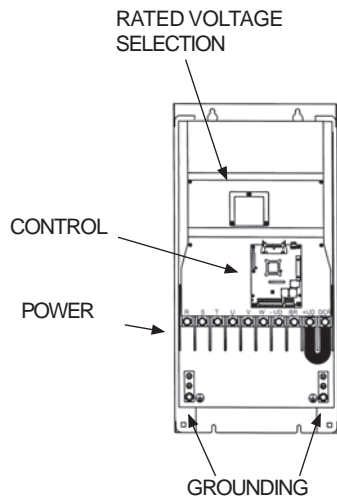

d) Size 8 models

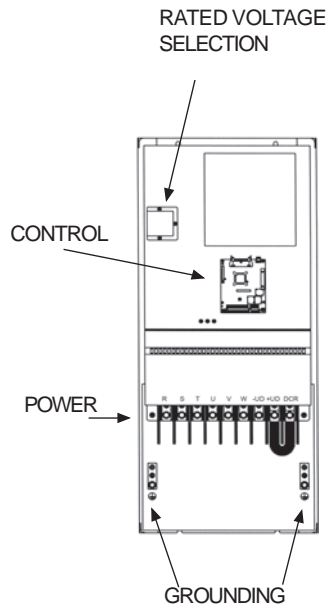

e) Size 9 and 10 models

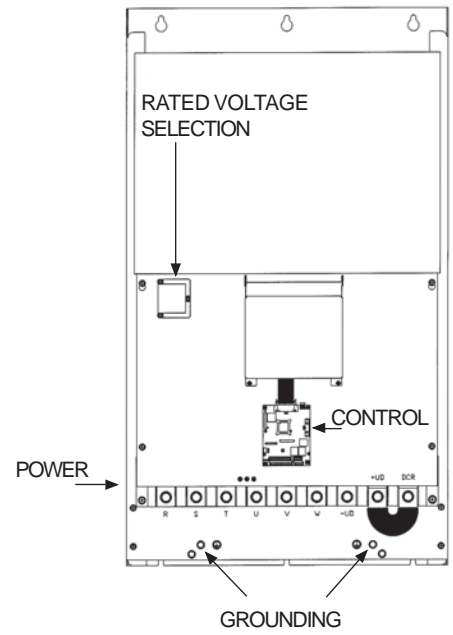

f) Size 8E

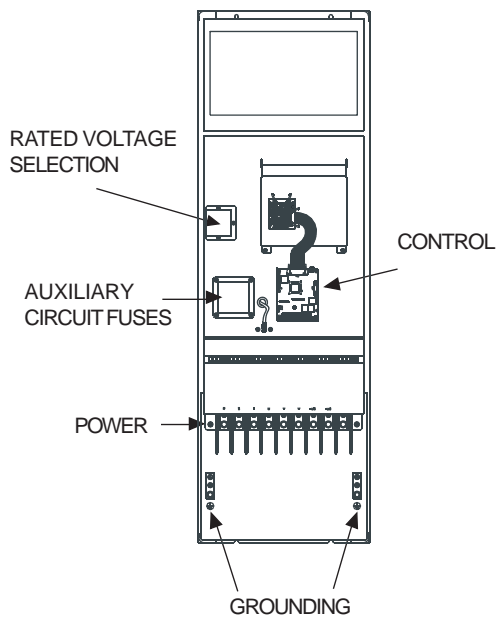

g) Size 10E

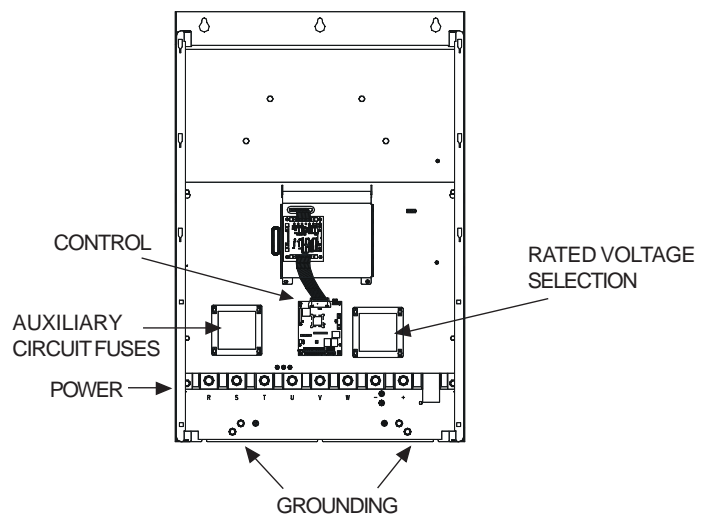

Figure 3.7 c) to g) - Location of the Power/Grounding/Control Connections and Rated Voltage

### 3.2.3 Rated voltage selection

The following models of CFW09 inverter series have a jumper for rated voltage selection:

- $\geq 86A/380-480V$ .
- $\geq 44A/500-600V$ .
- 500-690V models.



#### ATTENTION!

It is necessary to adjust the jumper in models 380-480V when the power supply voltage is different from 440V and 460V. Also in models 500-600V and 500-690V when the power supply voltage is different from 550V, 575V and 600V.

#### PROCEDURE:

- ☑ 380-480V models :  
Remove jumper on the LVS1 board (or from the CIP2 for models  $\geq 180A$ ) from position XC60 (440-460V) and insert it on the proper position according to the application line voltage.
- ☑ 500-600V models :  
Remove jumper on the LVS2 board from position XC62 (550V, 575V,600V) and insert it on the proper position according to the line voltage.
- ☑ 500-690V models :  
Remove jumper on the CIP3 board from position XC62 (550V, 575V,600V) and insert it on the proper position according to the line voltage.

a) LVS1(size 6 and 7, 380-480V)

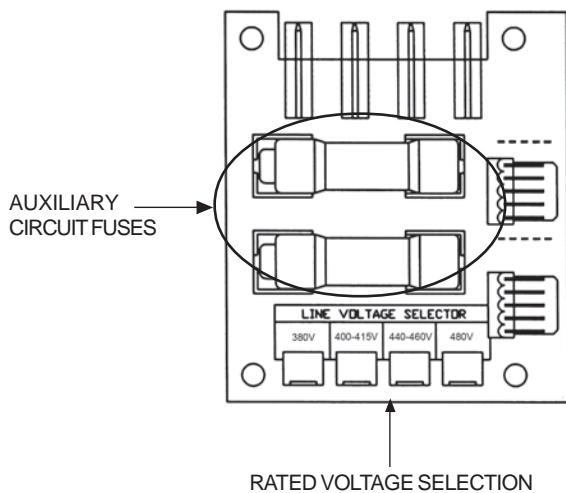

b) CIP2 (size 8, 9 and 10, 380-480V)

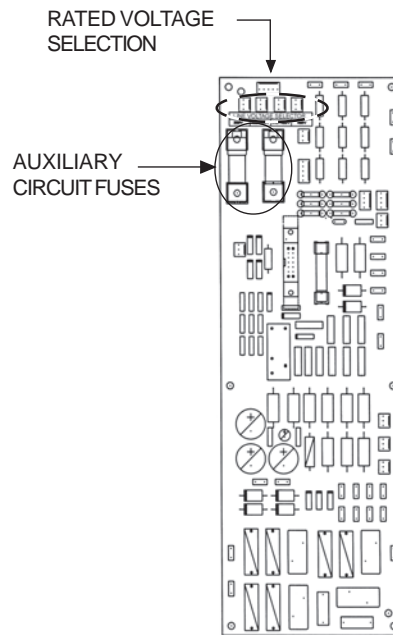
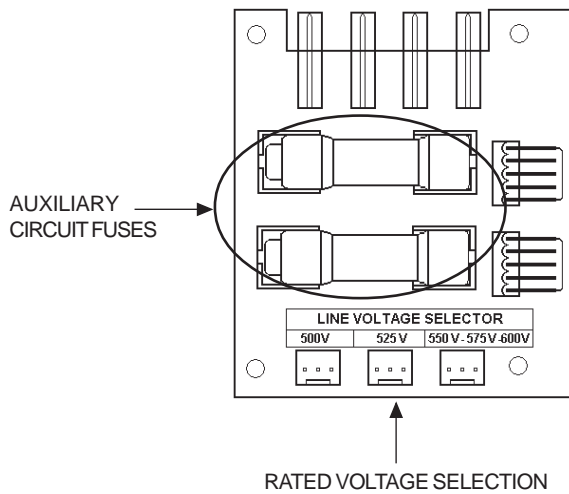

Figure 3.8 a) b) - Rated Voltage Selection on boards LVS1, CIP2, LVS2 and CIP3

c) LVS2 (size 7, 500-600V)



d) CIP3 (size 8E and 10E, 500-690V)

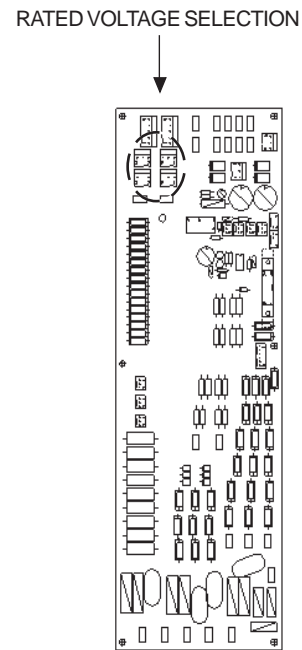

Figure 3.8 c) d) – Rated Voltage Selection on boards LVS1, CIP2, LVS2 and CIP3

### 3.2.4 Power/Grounding Wiring and Fuses



**ATTENTION!**

Sensitive equipment (PLC's, temperature controllers, thermocouples, etc.) and its wiring must stay at a minimum distance of 10 in (0.25m) from the frequency inverters, the reactors and from the input and motor power cables.



**ATTENTION!**

When flexible wires are used for power and grounding connections it is necessary to provide appropriate crimp terminals.

Use wire sizing and fuses as recommended in Table 3.5.

**CHAPTER 3 - INSTALLATION**

CFW-09 Rating A/volts		Power Cables mm <sup>2</sup> (AWG/MCM)		Grounding Cables mm <sup>2</sup> (AWG/MCM)		Max. Power Terminal Cable Size mm <sup>2</sup> (AWG/MCM)	High Speed Semiconductor Fuse - A	Fuse I <sup>2</sup> t @25°C A <sup>2</sup> s
CT	VT	CT	VT	CT	VT			
2.9/500-600	4.2/500-600	1.5 (14)	1.5 (14)	2.5 (12)	2.5 (12)	4.0 (10)	15	500
3.6/380-480	-	1.5 (14)	-	2.5 (12)	-	4.0 (10)	15	500
4.0/380-480	-	1.5 (14)	-	2.5 (12)	-	4.0 (10)	15	500
4.2/500-600	7.0/500-600	1.5 (14)	2.5 (12)	2.5 (12)	2.5 (12)	4.0 (10)	15	500
5.5/380-480	-	1.5 (14)	-	2.5 (12)	-	4.0 (10)	25	500
6.0/220-230	-	2.5 (12)	-	2.5 (12)	-	4.0 (10)	25	500
7.0/220-230	-	2.5 (12)	-	2.5 (12)	-	4.0 (10)	25	500
7.0/500-600	10/500-600	2.5 (12)	2.5 (12)	2.5 (12)	2.5 (12)	4.0 (10)	25	500
9.0/380-480	-	2.5 (12)	-	2.5 (12)	-	4.0 (10)	25	500
10/220-230	-	2.5 (12)* <sup>1</sup> 4.0 (12)* <sup>2</sup>	-	2.5 (12)	-	4.0 (10)	25 <sup>1</sup> 35 <sup>2</sup>	500
10/500-600	12/500-600	2.5 (12)	2.5 (12)	2.5 (12)	2.5 (12)	4.0 (10)	25	500
12/500-600	14/500-600	2.5 (12)	2.5 (12)	2.5 (12)	4.0 (10)	4.0 (10)	35	500
13/220-230	-	2.5 (12)	-	2.5 (12)	-	4.0 (10)	35	500
13/380-480	-	2.5 (12)	-	4.0 (10)	-	4.0 (10)	35	500
14/500-600	-	2.5 (12)	-	4.0 (10)	-	4.0 (10)	35	500
16/220-230	-	2.5 (12)	-	4.0 (10)	-	2.5 (12) 4.0 (10)	35	500
16/380-480	-	2.5 (12)	-	4.0 (10)	-	4.0 (10)	35	500
22/500-600	27/500-600	4.0 (10)	6.0 (8)	4.0 (10)	6.0 (8)	25 (4)	50	7200
24/220-230	-	4.0 (10)	-	4.0 (10)	-	4.0 (10)	35	500
24/380-480	-	4.0 (10)	-	4.0 (10)	-	4.0 (10)	35	1300
27/500-600	32/500-600	6.0 (8)	16 (6)	6.0 (8)	16 (6)	25 (4)	50	7200
28/220-230	-	6.0 (8)	-	6.0 (8)	-	6.0 (8)	50	1300
30/380-480	36/380-480	6.0 (8)	16 (6)	6.0 (8)	16 (6)	16 (6)	50	2100
32/500-600	-	16 (6)	-	16 (6)	-	25 (4)	50	7200
38/380-480	45/380-480	16 (6)	16 (6)	16 (6)	16 (6)	25 (4)	50	2100
44/500-600	53/500-600	16 (6)	16 (6)	16 (6)	16 (6)	120 (250)	63	10000
45/220-230	-	16 (6)	16 (6)	16 (6)	16 (6)	25 (4)	63	2450
45/380-480	54/380-480	16 (6)	16 (6)	16 (6)	16 (6)	25 (4)	63	2100
53/500-600	63/500-600	25 (4)	25 (4)	16 (6)	16 (6)	120 (250)	80	10000
54/220-230	68/220-230	16 (6)	25 (4)	16 (6)	16 (6)	50 (1)	80	2100
60/380-480	70/380-480	25 (4)	25 (4)	16 (6)	16 (6)	50 (1)	80	4000
63/500-600	79/500-600	25 (4)	25 (3)	16 (6)	16 (6)	120 (250)	80	10000
70/220-230	86/220-230	25 (4)	35 (2)	16 (6)	16 (6)	50 (1)	100	4000
70/380-480	86/380-480	25 (4)	35 (2)	16 (6)	16 (6)	50 (1)	100	4000
79/500-600	99/500-600	25 (3)	50 (1)	16 (6)	25 (4)	120 (250)	125	15000
86/220-230	105/220-230	35 (2)	50 (1)	16 (6)	25 (4)	50 (1)	125	4000
86/380-480	105/380-480	35 (2)	50 (1)	16 (6)	25 (4)	120 (250)	125	6000
100/660-690	127/660-690	50 (1)	70 (1/0)	25 (4)	35 (2)	150 (300)	250	320000
105/220-230	130/220-230	50 (1)	70 (1/0)	25 (4)	35 (2)	120 (250)	250	6000
105/380-480	130/380-480	50 (1)	70 (1/0)	25 (4)	35 (2)	120 (250)	250	6000
107/500-690	147/500-690	50 (1)	70 (1/0)	25 (4)	35 (2)	150 (300)	250	320000
127/660-690	179/660-690	70 (1/0)	95 (3/0)	35 (2)	50 (1)	150 (300)	250	320000
130/220-230	150/220-230	70 (1/0)	95 (3/0)	35 (2)	50 (1)	120 (250)	250	6000
142/380-480	174/380-480	70 (1/0)	95 (3/0)	35 (2)	50 (1)	120 (250)	250	6000
147/500-690	196/500-690	70 (2/0)	95 (3/0)	35 (2)	50 (1)	150 (300)	250	320000
179/660-690	179/660-690	95 (3/0)	95 (3/0)	35 (2)	50 (1)	250	250	320000
180/380-480	-	95 (3/0)	-	50 (1)	50 (1)	150 (300)	250	320000
211/380-480	-	150 (300)	-	70 (1/0)	-	150 (300)	315	320000
211/500-690	-	150 (300)	185 (300)	70 (1/0)	70 (1/0)	150 (300)	250	320000
225/660-690	259/660-690	150 (300)	185 (300)	70 (1/0)	70 (1/0)	2x240 (2x500)	315	320000
240/380-480	-	150 (300)	-	70 (1/0)	-	150 (300)	315	320000
247/500-690	315/500-690	150 (300)	2x70 (2x2/0)	70 (1/0)	70 (2/0)	2x240 (2x500)	500	320000
259/660-690	305/660-690	150 (300)	2x70 (2x2/0)	2x70 (2x2/0)	70 (2/0)	2x240 (2x500)	500	320000
305/660-690	340/660-690	2x70 (2x2/0)	2x120 (2x4/0)	70 (2/0)	120 (4/0)	2x240 (2x500)	500	320000
312/380-480	-	2x70 (2x2/0)	-	70 (2/0)	-	240 (500)	500	320000
315/500-690	343/500-690	2x70 (2x2/0)	2x150 (2x250)	70 (2/0)	120 (4/0)	2x240 (2x500)	500	320000
340/660-690	428/660-690	2x120 (2x4/0)	2x150 (2x250)	120 (4/0)	1x150 (1x250)	2x240 (2x500)	700	1051000
343/500-690	418/500-690	2x120 (2x4/0)	2x150 (2x250)	120 (4/0)	1x150 (1x250)	2x240 (2x500)	700	320000
361/380-480	-	2x120 (2x4/0)	-	120 (4/0)	-	240 (500)	500	320000
418/500-690	472/500-690	2x120 (2x4/0)	2x150 (2x250)	120 (4/0)	1x150 (1x250)	2x240 (2x500)	700	1051000
428/660-690	428/660-690	2x150 (2x250)	2x150 (2x250)	1x150 (1x250)	1x150 (1x250)	2x240 (2x500)	700	1445000
472/500-690	555/500-690	2x150 (2x250)	3x120 (3x4/0)	1x150 (1x250)	2x95 (2x3/0)	2x240 (2x500)	900	1445000
450/380-480	-	2x150 (2x250)	-	150 (250)	-	2x240 (2x500)	700	1051000
515/380-480	-	3x120 (3x4/0)	-	2x70 (2x2/0)	-	2x240 (2x500)	900	1445000
600/380-480	-	3x150 (3x250)	-	2x95 (2x3/0)	-	2x240 (2x500)	900	1445000

CT - Constant Torque / VT - Variable Torque

\*1 - Single phase connection / \*2 - Three phase connection

**Table 3.5 – Recommended Wiring/Fuses - Use 75°C copper wires only**



**NOTE!**

The wire sizing indicated in Table 3.5 are reference values only. The exact wire sizing depends on the installation conditions and the maximum acceptable line voltage drop.

The tightening torque is as indicated in Table 3.6. Use 75°C copper wire only.

CFW-09 Rating A/Volts	Grounding Wiring N.m (lbf.in)	Power Cables N.m (lbf.in)
6A to 13A/220-230 3.6A to 13A/380-480	1.00 (8.85)	1.76 (15.58)
16A to 28A/220-230 16A to 24A/380-480 2.9A to 14A/500-600	2.00 (17.70)	2.00 (17.70)
30A/380-480	4.50 (39.83)	1.40 (12.30)
45A/220-230 38A to 45A/380-480 22A to 32A/500-600	4.50 (39.83)	1.40 (12.30)
54A to 86A/220-230 60A to 86A/380-480	4.50 (39.83)	3.00 (26.10)
105A to 130A/220-230 105A to 142A/380-480 44A to 79A/500-600	15.50 (132.75)	15.50 (132.75)
180A to 240A/380-480	15.50 (132.75)	30.00 (265.50)
312A to 600A/380-480 107A to 472A/500-690 100A to 428A/660-690	30.00 (265.50)	60.00 (531.00)

**Table 3.6** - Recommended tightening torque for power and grounding connections

**Line Fuses**

- ☑ For protecting the input rectifier diodes and the wiring, use UR Type (Ultra-Rapid) fuses with  $i^2t$  equal or lower than indicated in table 3.5.
- ☑ Standard fuses may be used optionally at the input with currents as indicated in Table 3.5, or circuit breakers dimensioned for 1.2 x rated inverter input current for the CT or the VT operation (see items 9.1.2 to 9.1.5).  
However in this case, only the installation will be protected against short-circuit, but not the diodes of the rectifier bridge at the inverter input. This option may damage the inverter in case of shortcircuit of some internal component.

3.2.5 Power Connections

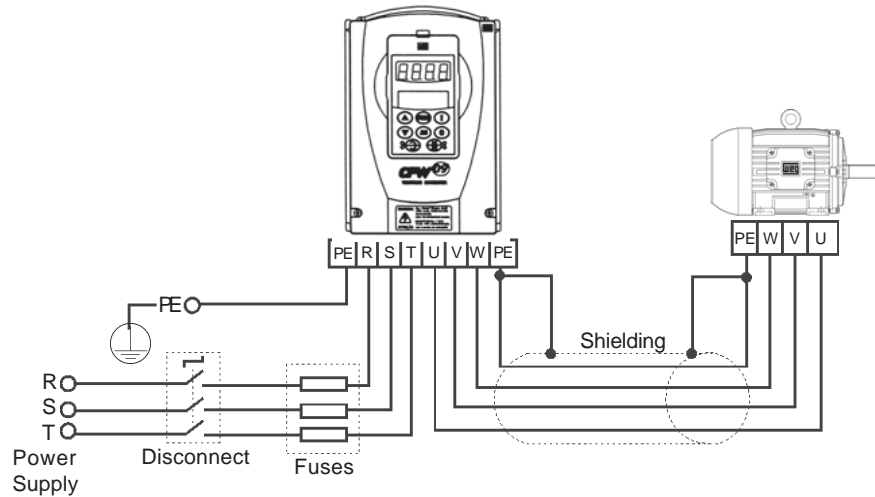

Figure 3.9 – Power/Grounding Connections

3.2.5.1 AC Input Connection



**DANGER!**

Provide an AC input disconnecting switch to switch OFF input power to the inverter.

This device shall disconnect the inverter from the AC input supply when required (e.g. during maintenance services). However it cannot be used as an emergency stop device.



**ATTENTION!**

The neutral conductor of the AC input for the inverter must be physically grounded, but do not use it for grounding purpose of the inverter(s).



**ATTENTION!**

Set jumper to select the rated line voltage 380-480V. For inverters 86A or higher, Refer to Section 3.2.3.



**NOTE!**

The AC input voltage must be compatible with the inverter rated voltage.

**Supply line capacity:**

- ☑ The CFW-09 is suitable for use in circuits capable of supplying not more than 30.000A (rms) symmetrical (230V/480V/600V/690V).
- ☑ The CFW-09 can be installed on power supplies with a higher fault level provided that adequate protection is provided by the fuses or circuit breaker.

**DC Link Inductor/Line Reactor**

See Item 8.7 relating to the requirement for using the Line Reactor / DC Link Inductor.



**NOTE!**

Capacitors for power factor correction are not required at the input (R, S,T) and they **MUST** not be connected at the output (U, V, W).

### 3.2.5.2 Output Connections

The inverter is provided with electronic protection against motor overload. This protection must be set according the specific motor. When the same inverter drives several motors, use individual overload relays for each motor. Maintain the electrical continuity of the motor cable shield.



#### ATTENTION!

If a disconnect switch or a contactor is inserted in the motor supply line, DO NOT operate the disconnect with the motor running or when inverter is enabled. Maintain the electrical continuity of the motor cable shield.

#### Dynamic Braking (DB)

With the Dynamic Braking (DB) option, the DB resistor shall be mounted externally. Figure 8.22 shows how to connect the DB resistor. Size it according to the application, not exceeding the maximum current of the braking circuit.

Use twisted cable for the connection between inverter and DB resistor. Provide physical separation between this cable and the signal and control cables. When the DB resistor is mounted inside the panel, consider the watt loss generated when the enclosure size and ventilation required are calculated.

### 3.2.5.3 Grounding Connections



#### DANGER!

Inverters must be grounded for safety purposes (PE). The earth or ground connection must comply with the local regulations. For grounding use cables with cross section as indicated in Table 3.5. Make the ground connection to a grounding bar or to the general grounding point (resistance  $\leq 10$  ohms).



#### DANGER!

Do not share the ground wiring with other equipment that operate with high current (for instance, high voltage motors, welding machines, etc). If several inverters are used together, Refer to Figure 3.10.

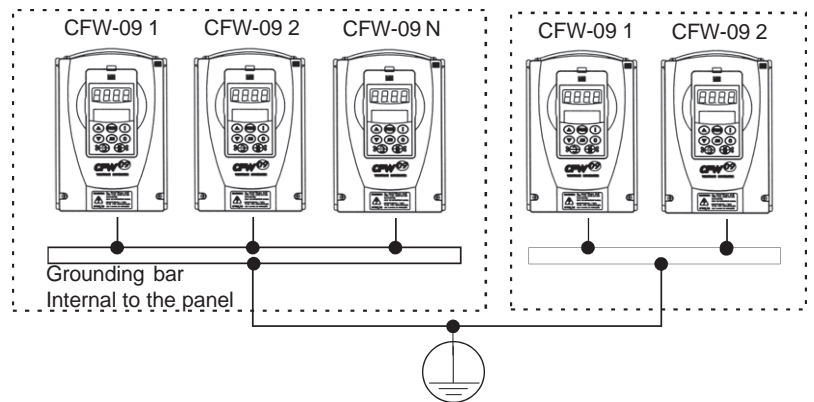

Figure 3.10 – Grounding connections for more than one inverter



**ATTENTION!**

Do not use the neutral from the main power supply to ground the drive.

**EMI**

When electromagnetic interference (EMI), generated by the inverter, causes problems with other equipment, use shielded wires, or install the motor wires in metallic conduits. Connect one end of the shielding to the inverter grounding point and the other end to the motor frame.

**Motor frame**

Always ground the motor frame. Ground the motor in the panel where the inverter is installed or ground it to the inverter. The inverter output wiring must be laid separately from the input wiring, as well as from the control and signal cables.

3.2.5.4 IT Networks



**ATTENTION!**

For IT networks (also known as ungrounded or high earthing impedance networks) it is necessary to consider the following:

- ☑ Models 180A to 600A/380-480V, 2.9A to 79A/500-600V, 107A to 472A/ 500-690V and 100A to 428A/660-690V have a varistor and capacitor connected between input phase and ground that must be disconnected if an IT network is used for that, remove the jumper as shown in figure 3.11.
- ☑ In 500-600V/500-690V/660-690V models, the jumper is accessible taking out (models 2.9A to 14A/500-600V) or opening (models 22A to 79A/500-600V, 107A to 211A/500-690V and 100A to 179A/660-690V) the front cover or taking out the connections cover (247A to 472A/500-600V and 225A to 428A/660-690V).
- ☑ In models 180A to 600A/380-480V, besides opening or taking out the front cover(s), it is required to remove the control board mounting plate (shield).
- ☑ The external RFI filters that are necessary in order to fulfill the requirements of European EMC Directive as stated in item 3.3, cannot be used with IT networks.
- ☑ The user must check and assume the responsibility of personnel electrical shock risk when using inverters in IT networks.

About the use of a differential relay at the inverter input:

- The indication of phase-to-ground short-circuit must be processed by the user, in order to indicate only a fault message or to turn off the inverter.
- Check with the relay manufacturer its proper operation with frequency inverters, because of the existing high-frequency leakage currents flowing through the inverter, cable and motor parasitic capacitances to the earth.

a) Models 180A to 240A/380-480V

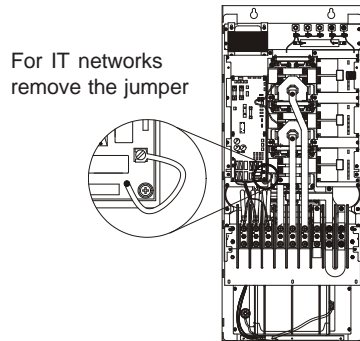

b) Models 312A to 600A/380-480V

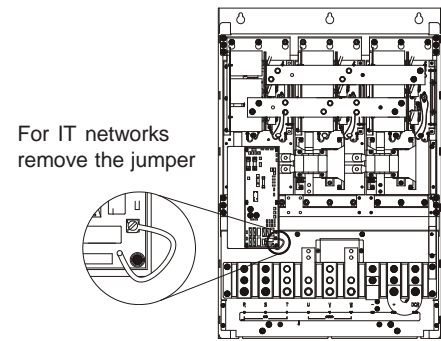

c) Models 2.9A to 14A/500-600V

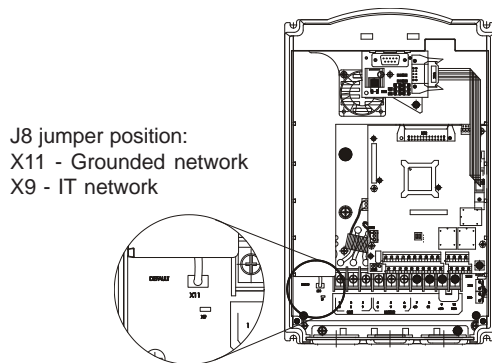

d) Models 22A to 32A/500-600V

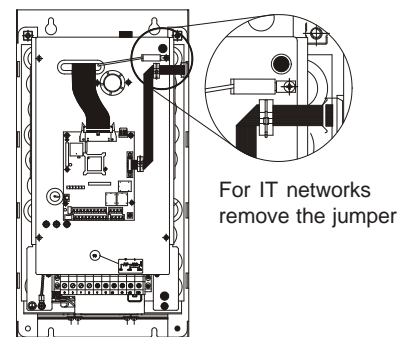

e) Models 44A to 79A/500-600V

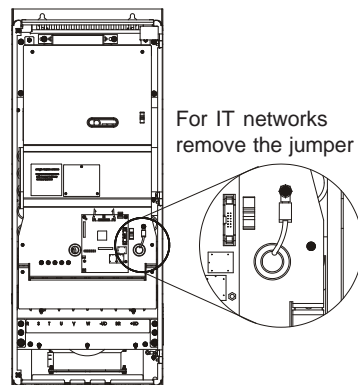

f) Models 107A to 211A/500-600V and 100A to 179A/660-690V

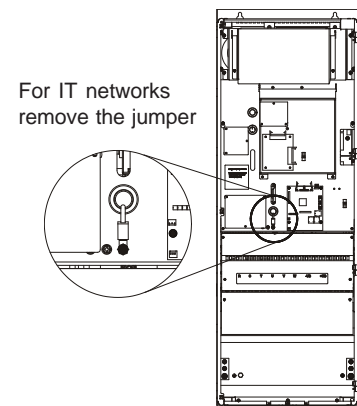

g) Models 247A to 472A/500-600V and 225A to 428A/660-690V

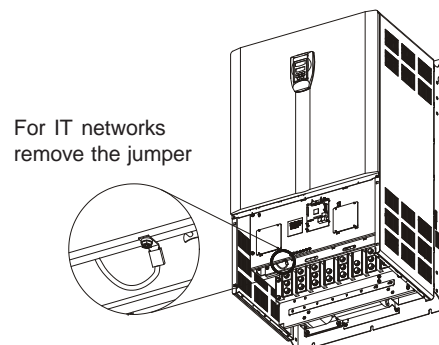

Figure 3.11 a) to g) - Location of jumper to disconnect the varistor and capacitor between input phase and ground - necessary only in models when IT network is used

3.2.6 Control Wiring

The control wiring (analog inputs/outputs, digital inputs/outputs and relay outputs) is made on the following terminal blocks of the Electronic Control Board CC9 (see location in Figures 3.7, Section 3.2.2).

XC1: Digital and Analog Signals

XC1A: Relay Outputs

The following diagram shows the control wiring with the digital inputs as active high as set on factory (jumper between XC1:8 and XC1:10).

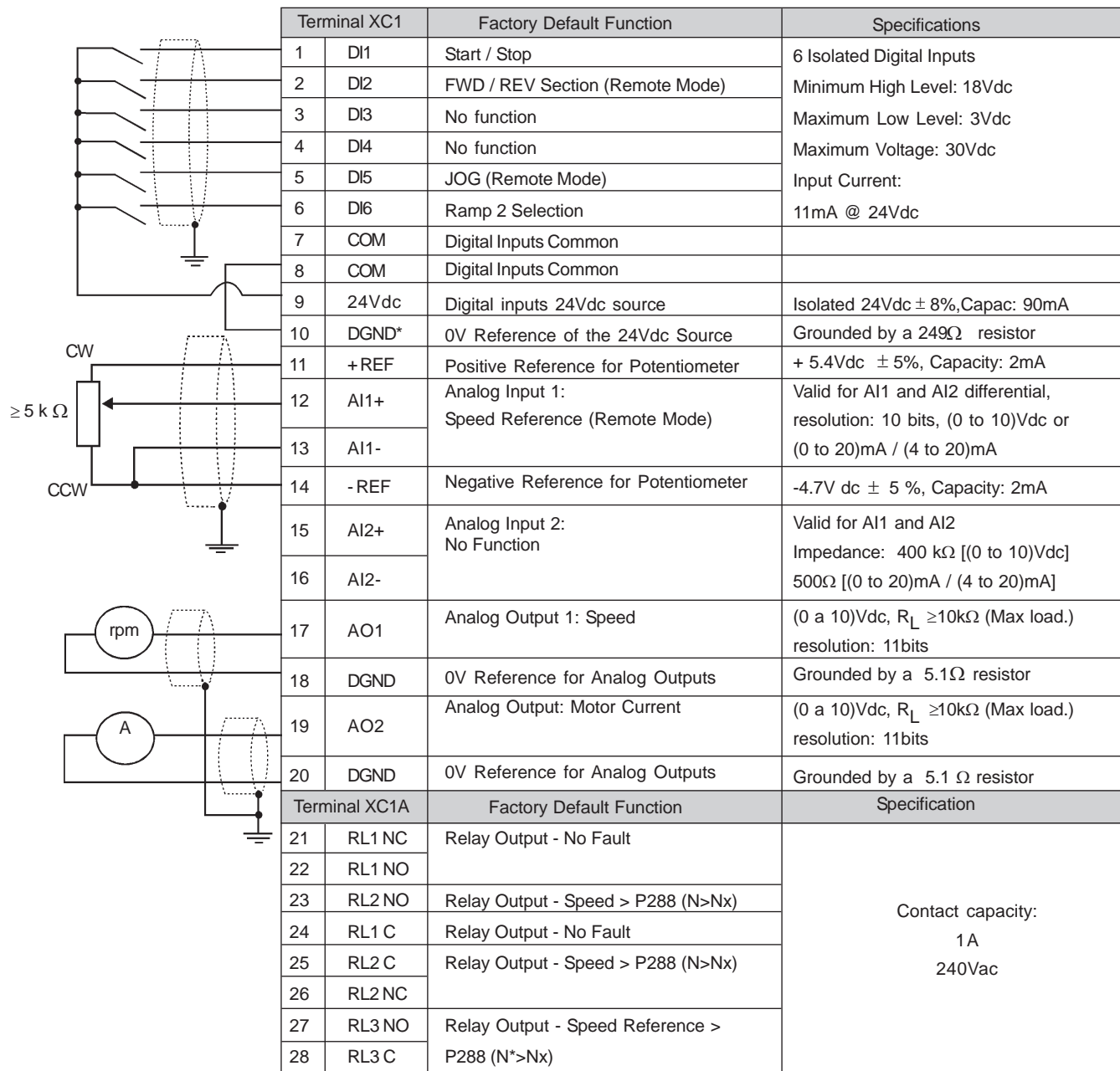

Note: **NC** = normally closed contact, **NO** = normally open contact, **C** = common

Figure 3.12 a) - XC1/XC1A Control Terminals Description (CC9 board) - Active High Digital Inputs

The following diagram shows the control wiring with the digital inputs as active low (without a jumper between XC1:8 and XC1:10).

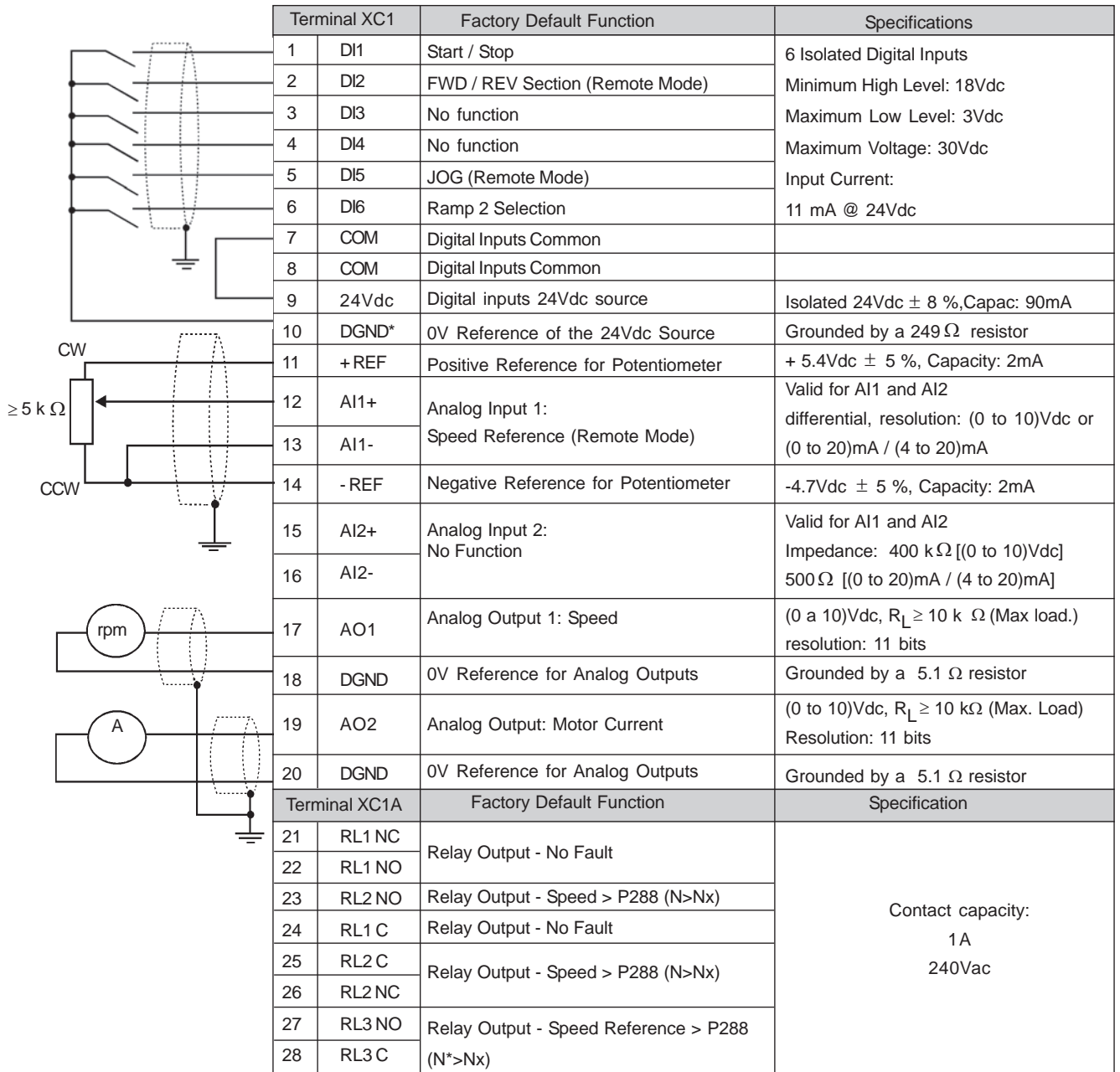

Note: **NC** = normally closed contact, **NO** = normally open contact, **C** = common

Figure 3.12 b) - XC1/XC1A Control Terminals Description (CC9 board) - Active Low Digital Inputs



**NOTE!**

For using the digital inputs as active low it is necessary to remove the jumper between XC1:8 and XC1:10 and place it between XC1:7 and XC1:9.

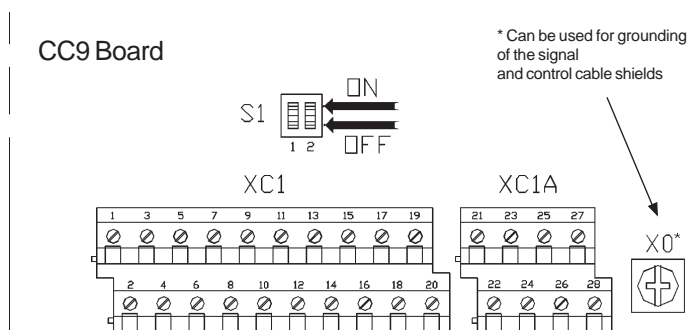

**Figure 3.13** - Dip switch position for (0 to 10)V or (0 to 20)mA/(4 to 20)mA selection

As a default the analogue inputs are selected as (0 to 10)V. This can be changed using the dip switch S1 on the control board.

Analog Input	Factory Default Function	Dip Switch	Selection
AI1	Speed Reference	S1.2	<b>OFF</b> (0 to 10)V (Factory Default) <b>ON</b> (4 to 20)mA / (0 to 20)mA
AI2	No Function	S1.1	<b>OFF</b> (0 to 10)V (Factory Default) <b>ON</b> (4 to 20)mA / (0 to 20)mA

**Table 3.7** - Dip switch configuration

Related Parameters: P221, P222, P234 to P240.

**During the signal and control wire installation you must follow these guidelines:**

- 1) Cable Cross Section: 0.5 mm<sup>2</sup> (20 AWG) to 1.5 mm<sup>2</sup> (14 AWG) ;
- 2) Max. Torque: 0.50 N.m (4.50 lbf.in);
- 3) XC1 wiring must be connected with shielded cables and installed separately from other wiring (power, control at 110V/220Vac, etc.), according to Table 3.8.

Inverter Model	Wiring Length	Min. Separation Distance
Output current ≤ 24A	≤ 100m (330ft)	≥ 10cm (4in)
	> 100m (330ft)	≥ 25cm (10in)
Output current ≥ 28A	≤ 30m (100ft)	≥ 10cm (4in)
	> 30m (100ft)	≥ 25cm (10in)

**Table 3.8** – Wiring separation distances

If the crossing of these cables is unavoidable, install them perpendicular, maintaining a minimum separation distance of 5 cm (2 in) at the crossing point.

Connect the shield as shown below:

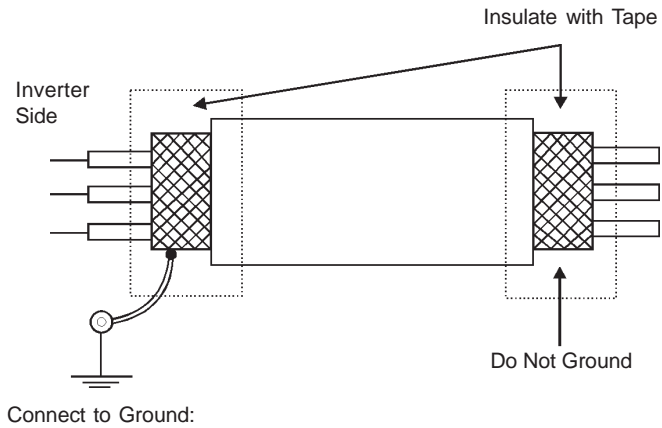

Screw located on the CC9 Board and on support plate of the CC9 Board

Figure 3.14 – Shield Connection



- 4) For wiring distances longer than 50m (150ft), it is necessary to use galvanic isolators for the XC1:11 to 20 analog signals.
- 5) Relays, contactors, solenoids or electromagnetic braking coils installed near inverters can generate interference in the control circuit. In order to eliminate this interference, connect RC suppressors in parallel with the coils of AC relays. Connect a free-wheeling diode in case of DC relays/coils.
- 6) When an external keypad (HMI) is used (Refer to Chapter 8), separate the cable that connects the keypad to the inverter from other cables, maintaining a minimum distance of 10cm (4in) between them.

### 3.2.7 Typical Terminal Connections

#### Connection 1 – Keypad Start/Stop (Local Mode)

With the **factory default setting**, you can operate the inverter in the local mode. This operation mode is recommended for users who are operating the inverter for the first time; without additional control connections. For start-up according to this operation mode, follow Chapter 5.

#### Connection 2 - 2-Wire Control Start/Stop (Remote Mode)

Valid for **factory default setting** and inverter operating in **remote mode**. For the factory default programming, the selection of the operation mode (Local/Remote) is made via the key  (default is Local). Press default of the key  to remote P220=3.

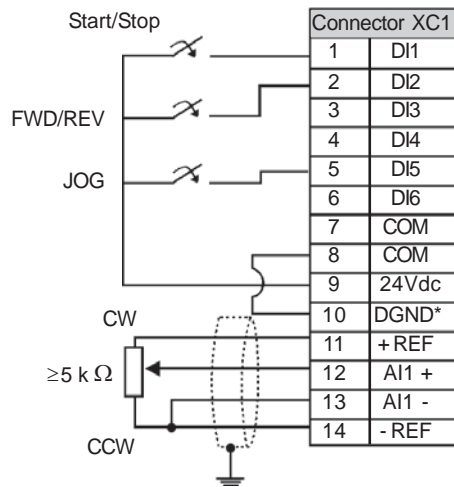

Figure 3.15 - XC1 (CC9) Wiring for Connection 2

### Connection 3 - 3-Wire Control Start/Stop

Selection of function Start/Stop with 3 wire control.

Parameters to be programmed:

**Set DI3 to START**

P265=14

**Set DI4 to STOP**

P266=14

Program P224=1 (DIx) if you want the 3 wire control in local mode.

Program P227=1 (DIx) if you want the 3 wire control in remote mode.

To program the rotation selection via DI2

**Set P223=4** if in Local Mode **or**

**Set P226=4** if in Remote Mode.

S1 and S2 are momentary push buttons, NO contact for Start and NC contact for Stop.

The speed reference can be via Analog Input AI (as in Connection 2), via keypad (HMI) (as in Connection 1), or via any other source. The function Start/Stop is described in Section 6 in this manual.

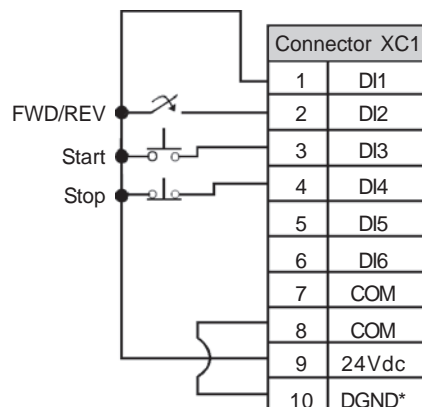

Figure 3.16 -XC1 (CC9) Wiring for Connection 3

Connection 4 - FWD Run / REV Run

Selection function FWD/REV.

Parameters to be programmed:

**Set DI3 to FORWARD Run**

P265=8

**Set DI4 to REVERSE Run**

P266=8

When the FWD Run / REV Run Function is programmed, the function is always active, in both local and remote operation modes.

At the same time, the keys **0** and **I** remain inactive (even when **P224=0** or **P227=0**)

The direction of rotation is defined automatically by the FWD Run / REV Run commands.

Clockwise rotation for Forward and Counter Clockwise rotation for Reverse.

The speed reference can be from any source (as in Connection 3).

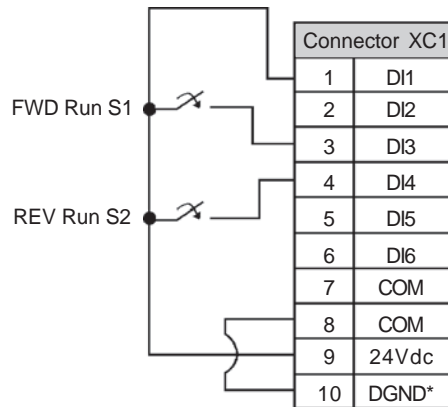

**Figure 3.17** - XC1 (CC9) Wiring for Connection 4

### 3.3 European EMC Directive - Requirements for Conforming Installations

The CFW-09 inverter series was designed taking in consideration safety and EMC aspects. The CFW-09 units do not have an intrinsic function until connected with other components (e.g. a motor). Therefore, the basic product is not CE marked for compliance with the EMC Directive. The end user takes personal responsibility for the EMC compliance of the whole installation. However, when installed according to the recommendations described in the product manual and including the recommended filters/EMC measures the CFW-09 fulfill all requirements of the EMC Directive (89/336/EEC) as defined by the Product Standard EN61800-3 "Adjustable speed electrical power drives systems", specific for variable speed drives systems.

Compliance of the whole series of the CFW-09 is based on testing some representative models. A Technical Construction File was checked and approved by a Competent Body.

The CFW-09 inverter series are intended for professional applications only. Therefore, the harmonic current emissions defined by the standards EN 61000-3-2 and EN 61000-3-2/A 14 do not apply.



#### NOTE!

- ☑ The 500-600V models are intended to be connected to an industrial low voltage power supply network, or public network which does not supply buildings used for domestic purpose - second environment according to the EN61800-3 standard.
- ☑ The filters specified in itens 3.3.2 and 3.3.3 do not apply to the 500-600V models.

#### 3.3.1 Installation

For installing the frequency inverters in accordance to the Product Standard EN61800-3 the following items are required:

1. Output cables (motor wiring) must be flexible armored or to be installed inside a metallic conduit or in a tray with equivalent attenuation.
2. The control (inputs and outputs) and signal wiring must be shielded or installed inside a metallic conduit or a tray with equivalent attenuation.
3. It is essential to follow the grounding recommendations presented in this manual.
4. **For first environment (low-voltage public network):** install an RFI filter (radio-frequency interference filter) at inverter input.
5. **For second environment (industrial areas) and unrestricted distribution (EN61800-3):** install an RFI filter at inverter input.



#### NOTE!

The use of a filter requires:

- ☑ The cable's shielding must be solidly connected to the common backplane, using brackets.
- ☑ The inverter and the filter must be mounted in close proximity, electrically connected, to one another, on the same metallic backplane. The wiring between them should be kept as short as possible.

Two filters are suggested: Epcos and Schaffner, detailed on the following itens 3.3.2 and 3.3.3. Figures 3.18 and 3.19 present a connection diagram for EMC filters, Epcos and Schaffner respectively.

**Description of conducted emission classes according to the standard EN61800-3:**

- ☑ Class B: first environment, unrestricted distribution
- ☑ Class A1: first environment, restricted distribution
- ☑ Class A2: second environment, unrestricted distribution



**ATTENTION!**

For installation with inverters that complies class A1 (first environment restricted distribution), note that this is a product of the restricted sales distribution class according to IEC/EN61800-3 (1996) + A11 (2000). In a domestic environment this product may cause radio interference in which case the user may be required to take adequate measures.



**ATTENTION!**

For installation with inverters that complies class A2 (second environment unrestricted distribution), note that this product is not intended to be used on a low-voltage public network which supplies domestic premises. Radio frequency interference is expected if used on such a network.

3.3.2 Epcos filters

The following tables 3.9, 3.10 and 3.11 show the Epcos filters for CFW09 frequency inverters with 380-480V, 500-600V and 660-690V power supply respectively, the maximum motor cable length for conducted emission classes A1, A2 and B (according to EN61800-3) and the electromagnetic radiation disturbance level.

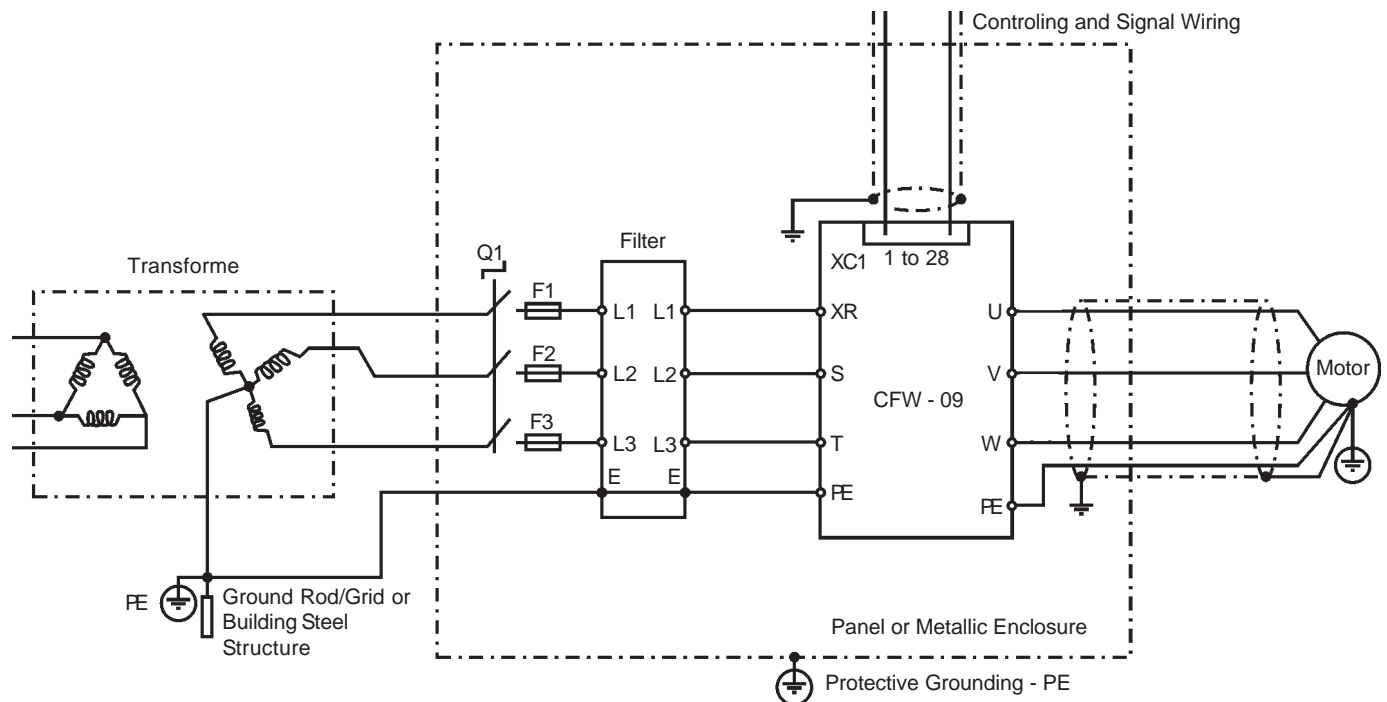

Figure 3.18 – Epcos EMC filters connection in CFW09 frequency inverters

**CHAPTER 3 - INSTALLATION**

**380-480V power supply:**

Inverter Model	Load Type	Epcos Input Filter	Maximum motor cable length according to conducted emission class (EN61800-3)			Inside metallic panel	Electromagnetic radiation disturbance level (Product Standard EN61800-3 (1996)+A11 (2000))
			Class A2	Class A1	Class B		
3,6A <sup>(2)</sup>	CT/VT	B84143A8R105	100m	50m	20m	NO	First environment, restricted distribution
4A <sup>(2)</sup>	CT/VT						Second environment, unrestricted distribution
5,5A <sup>(2)</sup>	CT/VT						Second environment, unrestricted distribution
9A <sup>(2)</sup>	CT/VT	B84143A16R105	N/A	100m	35m		Second environment, unrestricted distribution
13A	CT/VT						First environment, restricted distribution
16A	CT/VT	B84143A25R105	85m	50m	N/A		First environment, restricted distribution
24A	CT/VT	B84143A36R105					First environment, restricted distribution
30A	CT	B84143A50R105	100m	50m	N/A		First environment, restricted distribution
	VT						First environment, restricted distribution
38A <sup>(3)</sup>	CT	B84143A66R105	100m	50m	N/A		First environment, restricted distribution
	VT					First environment, restricted distribution	
45A <sup>(3)</sup>	CT	B84143A90R105	100m	25m	N/A	YES	Second environment, unrestricted distribution
	VT						Second environment, unrestricted distribution
60A	CT	B84143A120R105	100m	25m	N/A		First environment, restricted distribution
	VT						First environment, restricted distribution
70A	CT	B84143G150R110	N/A	100m	N/A		First environment, restricted distribution
	VT						First environment, restricted distribution
86A	CT	B84143G220R110	N/A	100m	N/A		First environment, restricted distribution
	VT						First environment, restricted distribution
105A	CT	B84143B320S20	100m	25m	N/A		First environment, restricted distribution
	VT						First environment, restricted distribution
142A <sup>(3)</sup>	CT	B84143B400S20	100m	25m	N/A	First environment, restricted distribution	
	VT					First environment, restricted distribution	
180A	CT/VT	B84143B600S20	100m	25m	N/A	First environment, restricted distribution	
211A	CT/VT					First environment, restricted distribution	
240A	CT/VT	B84143B1000S20 <sup>(1)</sup>	100m	25m	N/A	First environment, restricted distribution	
312A <sup>(3)</sup>	CT/VT					First environment, restricted distribution	
361A <sup>(3)</sup>	CT/VT	B84143B600S20	100m	25m	N/A	First environment, restricted distribution	
450A	CT/VT					First environment, restricted distribution	
515A	CT/VT	B84143B600S20	100m	25m	N/A	First environment, restricted distribution	
600A	CT/VT					First environment, restricted distribution	

N/A = Not Applicable – The inverters were not tested with these limits.

Notes:

(1) The RFI filter suggested above for model 600A/380-480V considers a power supply with 2% voltage drop. For a power supply with 4% voltage drop it's possible to use B84143B600S20 RFI filter. In this case, consider the same motor cable lengths and radiated emission data as shown in table above.

(2) Minimum output frequency = 2,9Hz.

(3) Minimum output frequency = 2,4Hz.

**Table 3.9 - Epcos filters list for CFW09 inverter series with 380-480V power supply**

**500-600V power supply:**

Inverter Model	Load Type	Epcos Input Filter	Maximum motor cable length according to conducted emission class (EN61800-3)			Inside metallic panel	Electromagnetic radiation disturbance level (Product Standard EN61800-3 (1996)+A11 (2000))				
			Class A2	Class A1	Class B						
107A/500-690V	CT	B84143B150S21	100m	25m	N/A	YES	First environment, restricted distribution				
	VT										
147A/500-690V	CT	B84143B250S21									First environment, restricted distribution
	VT										
211A/500-690V	CT/VT										First environment, restricted distribution
247A/500-690V	CT	B84143B400S125									Second environment, unrestricted distribution
	VT										
315A/500-690V	CT										Second environment, unrestricted distribution
	VT										
343A/500-690V	CT	B84143B600S125									Second environment, unrestricted distribution
	VT										
418A/500-690V	CT						Second environment, unrestricted distribution				
	VT										
472A/500-690V	CT						Second environment, unrestricted distribution				
	VT										

N/A = Not Applicable – The inverters were not tested with these limits.

Note: Minimum output frequency = 2.4Hz.

**Table 3.10** - Epcos filters list for CFW09 inverter series with 500-600V power supply

**660-690V power supply:**

Inverter Model	Load Type	Epcos Input Filter	Maximum motor cable length according to conducted emission class (EN61800-3)			Inside metallic panel	Electromagnetic radiation disturbance level (Product Standard EN61800-3 (1996)+A11 (2000))				
			Class A2	Class A1	Class B						
100A/660-690V and 107A/500-690V	CT	B84143B150S21	100m	25m	N/A	YES	First environment, restricted distribution				
	VT										
127A/660-690V and 147A/500-690V	CT	B84143B180S21									First environment, restricted distribution
	VT										
179A/660-690V and 211A/500-690V	CT/VT										First environment, restricted distribution
225A/660-690V and 247A/500-690V	CT	B84143B400S125									Second environment, unrestricted distribution
	VT										
259A/660-690V and 315A/500-690V	CT										Second environment, unrestricted distribution
	VT										
305A/660-690V and 343A/500-690V	CT	B84143B600S125									Second environment, unrestricted distribution
	VT										
340A/660-690V and 418A/500-690V	CT						Second environment, unrestricted distribution				
	VT										
428A/660-690V and 472A/500-690V	CT/VT						Second environment, unrestricted distribution				

N/A = Not Applicable – The inverters were not tested with these limits.

Note: Minimum output frequency = 2.4Hz.

**Table 3.11** - Epcos filters list for CFW09 inverter series with 660-690V power supply

3.3.3 Schaffner filters

The following tables 3.12 and 3.13 show the Schaffner filters list for CFW09 inverter series with 380-480V and 220-230V power supply, respectively.

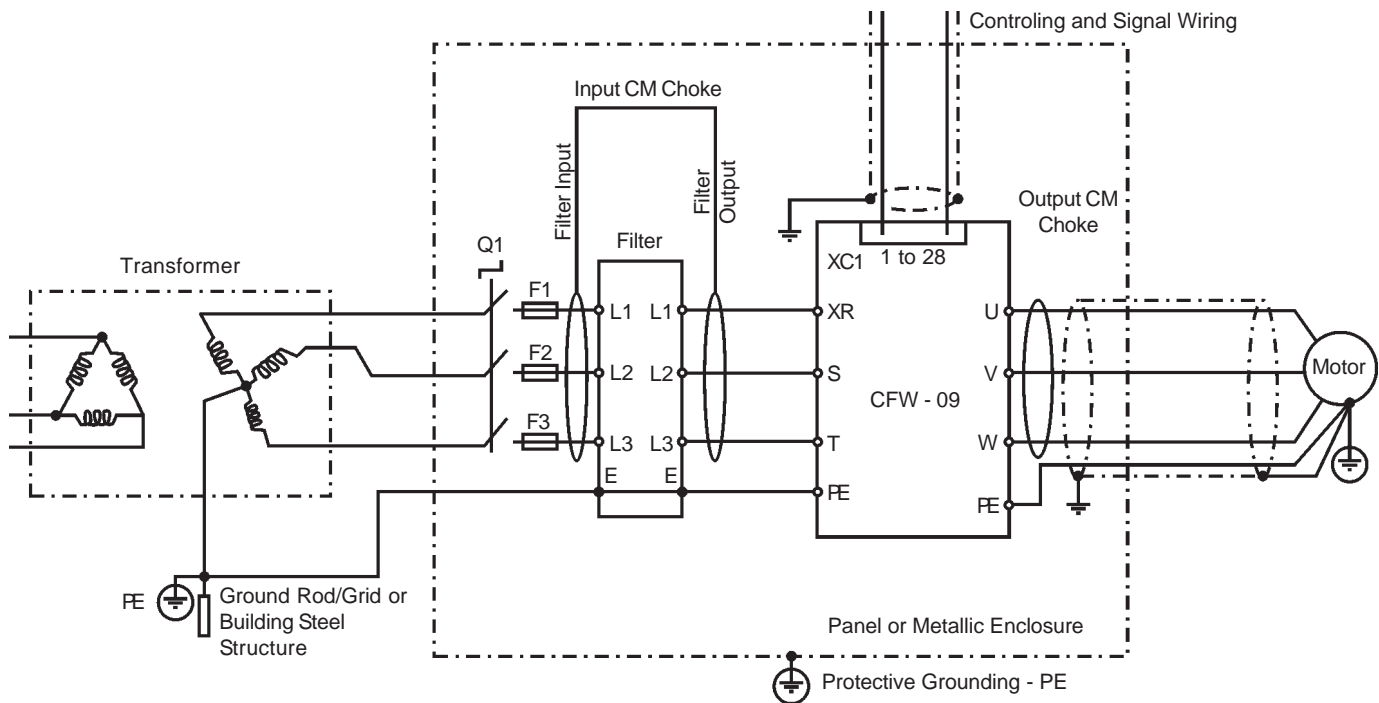

Figure 3.19 - Schaffner EMC filters connection in CFW09 frequency inverters

380-480V power supply:

Model	Optional Device	Input filter	Input CM Choke	Output CM Choke	Inside Metallic Panel	Electromagnetic radiation disturbance level (Product Standard EN61800-3 (1996) + A11 (2000) *1	Conducted Emission Class *2
3,6 A	RS-232	FN-3258-7-45	No	No	No	First environment, restricted distribution	B
4 A, 5 A	EBA RS-485 Serial Interface	FN-3258-7-45	No	No	No	Second environment, unrestricted distribution	B
9 A	EBA RS-485 Serial Interface	FN-3258-16-45	No	No	No	Second environment, unrestricted distribution	B
13 A	No	FN-3258-16-45	No	No	No	First environment, restricted distribution	B
16 A 24 A	No	FN-3258-30-47	No	No	No	First environment, restricted distribution	B
30 A	EBB RS-485 Serial Interface	FN-3258-55-52	Schaffner 203 (1151-042) - 2 turns (filter input side)	No	Yes	First environment, restricted distribution	A1
30 A 38 A	No	FN-3258-55-52	No	No	No	First environment, restricted distribution	A1
45 A	No	FN-3258-100-35	2 x Schaffner 203 (1151-042) - (filter input/output sides)	No	No	First environment, restricted distribution	A1

Table 3.12 - Schaffner filters list for CFW09 inverter series with 380-480 V power supply.

**380-480V power supply:**

Model	Optional Device	Input filter	Input CM Choke	Output CM Choke	Inside Metallic Panel	Electromagnetic radiation disturbance level (Product Standard EN61800-3 (1996) + A11 (2000) *1	Conducted Emission Class *2
45 A	EBA RS-485 Serial Interface	FN-3258-100-35	2 x Schaffner 203 (1151-042) - (filter input/ output sides)	No	No	First environment, restricted distribution	A1
45 A	EBB RS-485 Serial Interface	FN-3258-100-35	2 x Schaffner 203 (1151-042) - (filter input/output sides) Schaffner 203 (1151-042) 2 turns in the control cable	No	No	First environment, restricted distribution	A1
45 A	Profibus-DP 12 MBaud	FN-3258-100-35	2 x Schaffner 203 (1151-042) - (filter input/output sides)	No	No	First environment, restricted distribution	A1
60 A 70 A	No	FN-3258-100-35	No	No	Yes	Second environment, unrestricted distribution	A1
86 A 105 A	No	FN-3359-150-28	2 X Schaffner 203 (1151-042) Output filter side	2 X Schaffner 203 (1151-042) (UVW)	Yes	First environment, restricted distribution	A1
142 A	No	FN-3359-250-28	2 X Schaffner 167 (1151-043) output filter side	2 X Schaffner 167 (1151-043) (UVW)	Yes	First environment, restricted distribution	A1
180 A	No	FN-3359-250-28	Schaffner 159 (1151-044) output filter side	Schaffner 159 (1151-044) (UVW)	Yes	First environment, restricted distribution	A1
211 A 240 A 312 A 361 A	No	FN-3359-400-99	Schaffner 159 (1151-044) Output filter side	Schaffner 159 (1151-044) (UVW)	Yes	First environment, restricted distribution	A1
450 A	No	FN-3359-600-99	Schaffner 159 (1151-044) Output filter side	Schaffner 159 (1151-044) (UVW)	Yes	First environment, restricted distribution	A1
515A 600 A	No	FN-3359-1000-99	Schaffner 159 (1151-044) Output filter side	Schaffner 159 (1151-044) (UVW)	Yes	First environment, restricted distribution	A1

**Table 3.12 (cont.)** - Schaffner filters list for CFW09 inverter series with 380-480 V power supply.

## CHAPTER 3 - INSTALLATION

### 220V-230V power supply:

Model	Optional Device	Input filter	Common mode Ferrite (Input)	Common mode Ferrite (Output)	Inside Metallic Panel	Electromagnetic radiation disturbance level (Product Standard EN61800-3 (1996) + A11 (2000)) *1	Conducted Emission Class *2
6 A 1 phase	No	FS6007-16-06	No	Schaffner 203 (1151-042) 2 turns	No	First environment, restricted distribution	B
7 A 1 phase	No	FS6007-25-08	No	No	No	First environment, restricted distribution	B
10 A 1 phase	No	FS6007-36-08	No	No	No	First environment, restricted distribution	B
10 A 1 phase	EBA RS-485 Serial Interface	FS6007-36-08	No	No	No	First environment, restricted distribution	B
10 A 1 phase	EBB RS-485 Serial Interface	FS6007-36-08	2 x Schaffner 203 (1151-042) - (filter input/output sides (2 turns))	No	No	First environment, restricted distribution	B
6 A	No	FN-3258-7-45	No	No	No	First environment, restricted distribution	B
7 A 10 A 13 A	No	FN-3258-16-45	No	No	No	First environment, restricted distribution	B
16 A 24 A	No	FN-3258-30-47	No	No	No	First environment, restricted distribution	B
28 A	No	FN-3258-55-52	No	No	Yes	First environment, restricted distribution	A1
45 A	No	FN-3258-100-35	2 x Schaffner 203 (1151-042) - (filter input/output sides)	No	No	First environment, restricted distribution	A1
45 A	EBA RS-485 Serial Interface	FN-3258-100-35	2 x Schaffner 203 (1151-042) - (filter input/output sides)	No	No	First environment, restricted distribution	A1
45 A	EBB RS-485 Serial Interface	FN-3258-100-35	2 x Schaffner 203 (1151-042) - (filter input/output sides) Schaffner 203 (1151-042)choke- 2 turns in the control cable	No	No	First environment, restricted distribution	A1
45 A	Profibus-DP 12 MBaud	FN-3258-100-35	2 x Schaffner 203 (1151-042) - (filter input/output sides)	No	No	First environment, restricted distribution	A1
54 A 70 A	No	FN-3258-100-35	No	No	Yes	Second environment, unrestricted distribution	A1
86 A	No	FN-3258-130-35	2 X Schaffner 203 (1151-042) Filter output side	2 X Schaffner 203 (1151-042) (UVW)	Yes	First environment, restricted distribution	A1
105 A	No	FN-3359-150-28	2 X Schaffner 203 (1151-042) Filter output side	2 X Schaffner 203 (1151-042) (UVW)	Yes	First environment, restricted distribution	A1

**Table 3.13** - Schaffner filters list for CFW09 inverter series with 220-230V power supply.

Model	Optional Device	Input filter	Common mode Ferrite (Input)	Common mode Ferrite (Output)	Inside Metallic Panel	Electromagnetic radiation disturbance level (Product Standard EN61800-3 (1996) + A11 (2000)) *1	Conducted Emission Class *2
130 A	No	FN-3359-250-28	2 X Schaffner 167 (1151-043) Filter output side	2 X Schaffner 167 (1151-043) (UVW)	Yes	First environment, restricted distribution	A1

Notes:

\*1 - First environment/restricted distribution (Basic Standard CISPR 11):

30 to 230MHz: 30dB (uV/m) in 30m  
230 to 1000MHz: 37dB (uV/m) in 30m

Second environment/unrestricted distribution (Basic Standard CISPR 11: Group 2, class A):

30 to 230MHz: 40dB (uV/m) in 30m  
230 to 1000MHz: 50dB (uV/m) in 30m

\*2 - Motor shielded cable length: 20m.

Table 3.13 (cont.) - Schaffner filters list for CFW09 inverter series with 220-230V power supply.

### 3.3.4 EMC filter characteristics

The following table 3.14 shows the main technical characteristics of Epcos and Schaffner filters used in CFW09 inverter series. Figure 3.20 presents drawings of these filters.

WEG P/N	Filter	Manufacturer	Nominal current [A]	Power losses [W]	Weight [kg]	Drawing (figure 3.20)	Connector type	
0208.2126	B84143A8R105	Epcos	8	6	0.58	a	-	
0208.2127	B84143A16R105		16	9	0.90	b		
0208.2128	B84143A25R105		25	12	1.10	c		
0208.2129	B84143A36R105		36	18	1.75	d		
0208.2130	B84143A50R105		50	15	1.75			
0208.2131	B84143A66R105		66	20	2.7	e		
0208.2132	B84143A90R105		90	27	4.2	f		
0208.2133	B84143A120R105		120	39	4.9	g		
0208.2134	B84143G150R110		150	48	8.0	h		
0208.2135	B84143G220R110		220	60	11.5	i		
0208.2136	B84143B320S20		320 (*)	21	21	j		
0208.2137	B84143B400S20		400	33	21			
0208.2138	B84143B600S20		600	57	22	k		
0208.2139	B84143B1000S20		1000	99	28	l		
0208.2140	B84143B150S21		150	12	13	m		
0208.2141	B84143B180S21		180	14	13			
0208.2142	B84143B250S21		250	14	15	n		
0208.2143	B84143B400S125		400	33	21	o		
0208.2144	B84143B600S125		600	57	22	p		
0208.2072	FS6007-16-06		Schaffner	16	4	0.9		q
0208.2073	FS6007-25-08	25		4	1.0	r	/08	
0208.2074	FS6007-36-08	36		5	1.0		/08	
0208.2075	FN3258-7-45	7		3.8	0.5	s	/45	
0208.2076	FN3258-16-45	16		6	0.8		/45	
0208.2077	FN3258-30-47	30		12	1.2		/47	
0208.2078	FN3258-55-52	55		26	1.8		/52	
0208.2079	FN3258-100-35	100		35	4.3		/35	
0208.2080	FN3258-130-35	130		43	4.5		/35	
0208.2081	FN3359-150-28	150		28	6.5		t	/28
0208.2082	FN3359-250-28	250		57	7.0			/28
0208.2083	FN3359-400-99	400		50	10.5	Bus /99		
0208.2084	FN3359-600-99	600		65	11			
0208.2085	FN3359-1000-99	1000		91	18			
0208.2086	1151-042							
0208.2087	1151-043							
0208.2088	1151-044							

Note: (\*) According to the manufacturer, this filter can be used up to 331A.

Table 3.14 – Technical specifications of EMC filters for the CFW09 inverter series.

## CHAPTER 3 - INSTALLATION

### a) EPCOS B84143A8R105 Filter

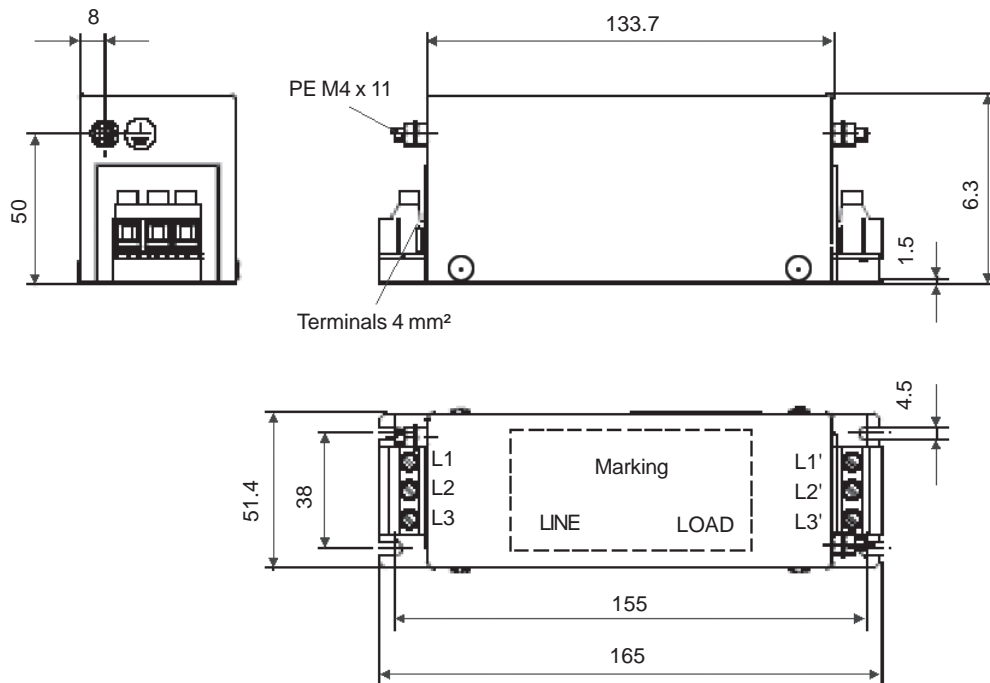

### b) EPCOS B84143A16R105 Filter

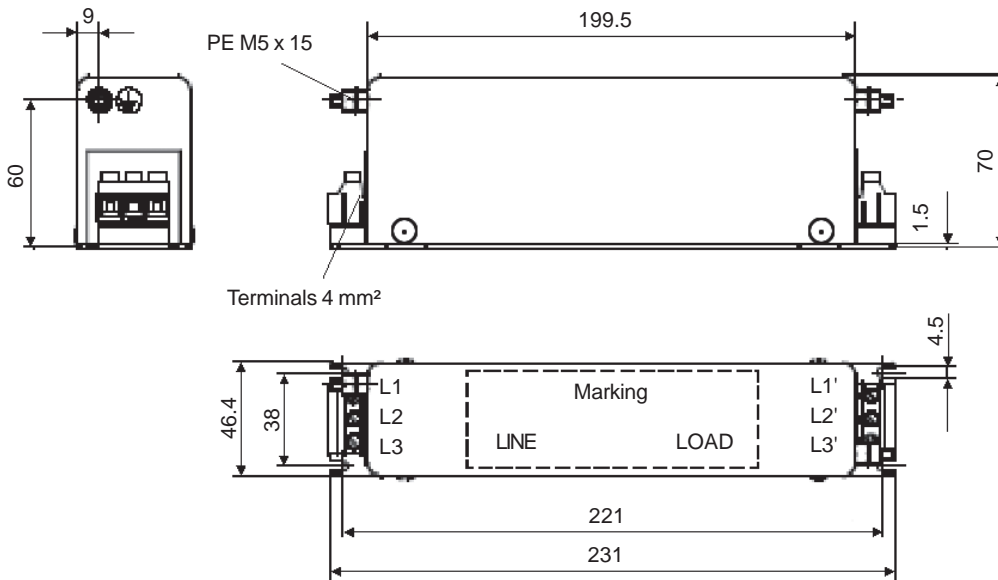
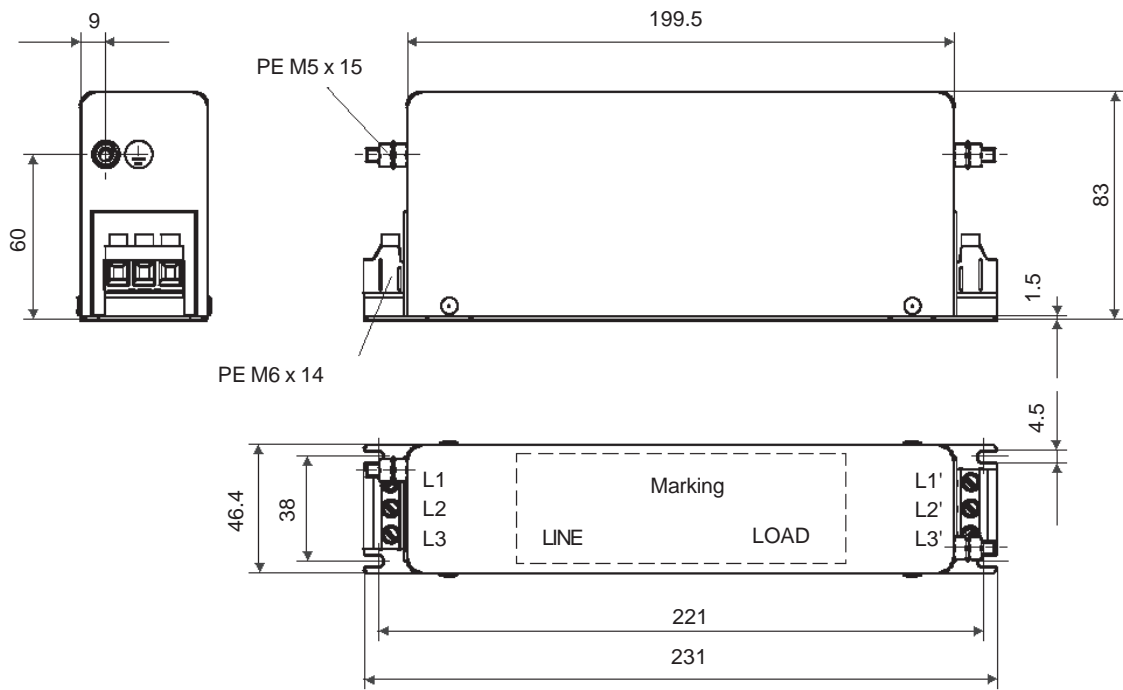

Figure 3.20 a) b) - EMC filters for CFW-09 inverter series [dimensions in mm]

c) EPCOS B84143A25R105 Filter



d) EPCOS B84143A36R105 and B84143A50R105 Filter

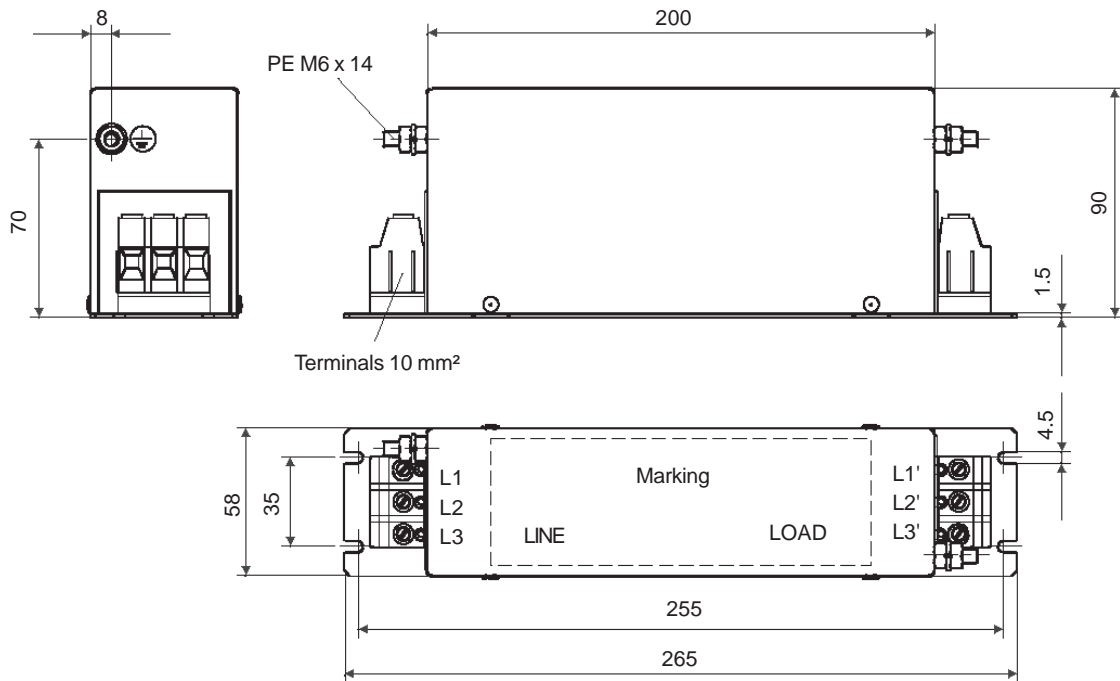
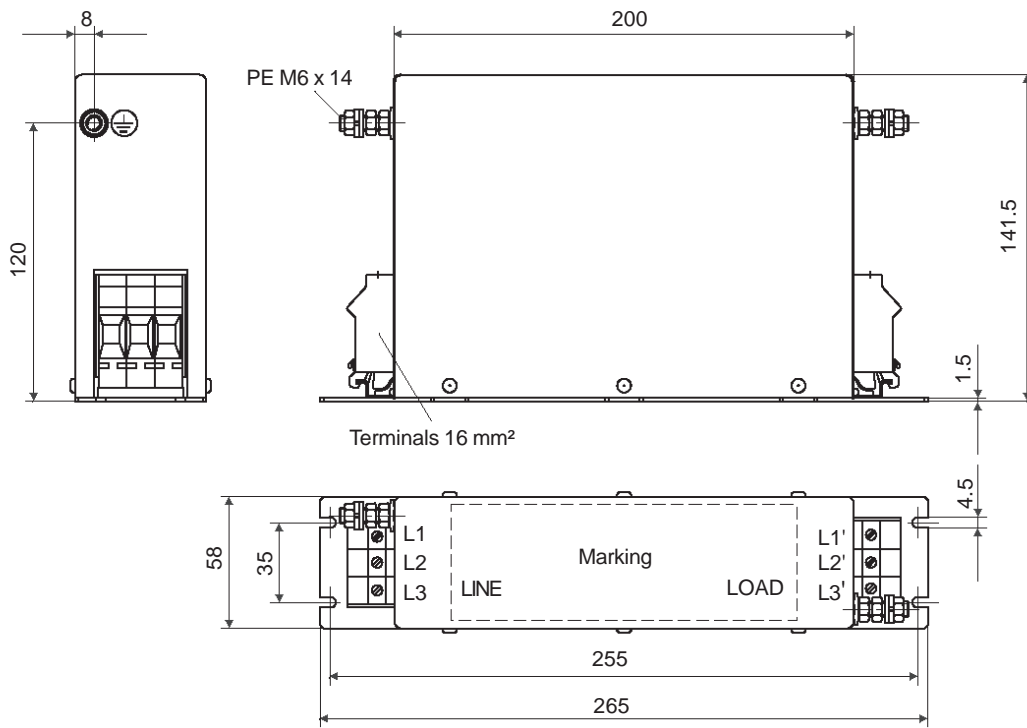

Figure 3.20 c) d) - EMC filters for CFW-09 inverter series [dimensions in mm]

## CHAPTER 3 - INSTALLATION

### e) EPCOS B84143A66R105 Filter



### f) EPCOS B84143A90R105 Filter

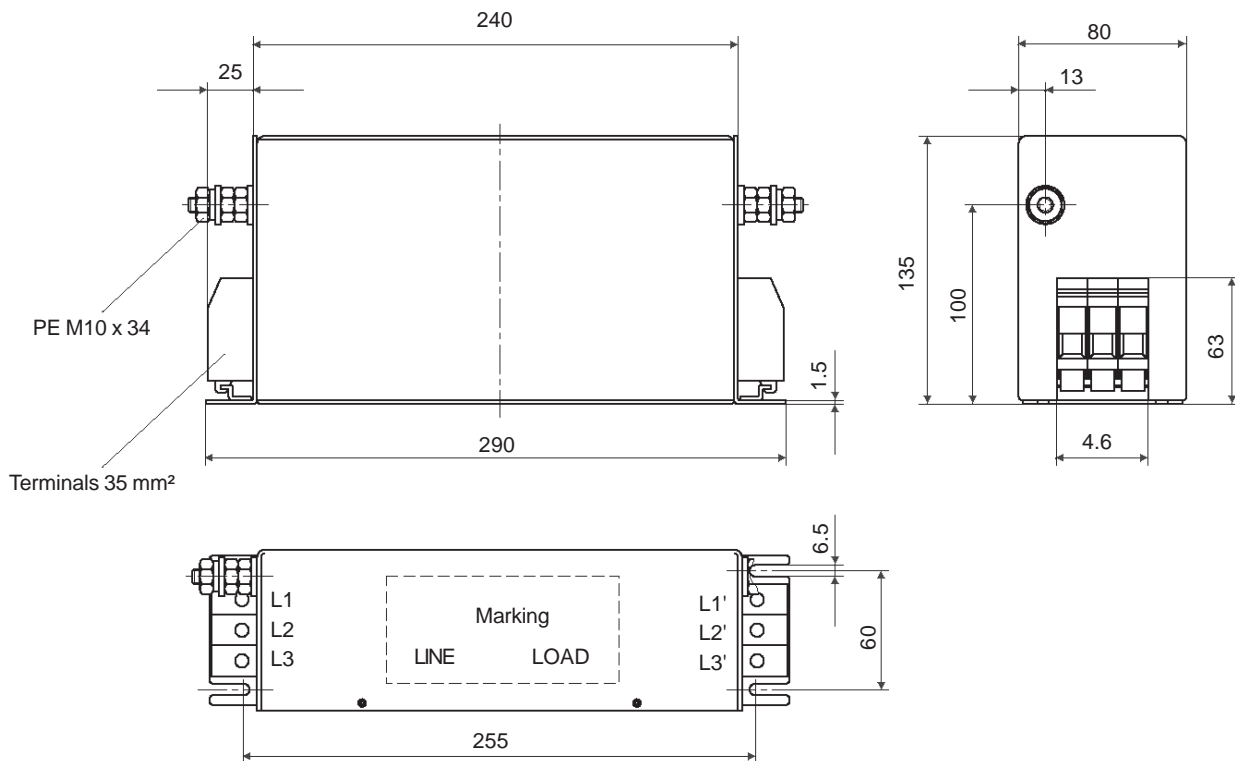
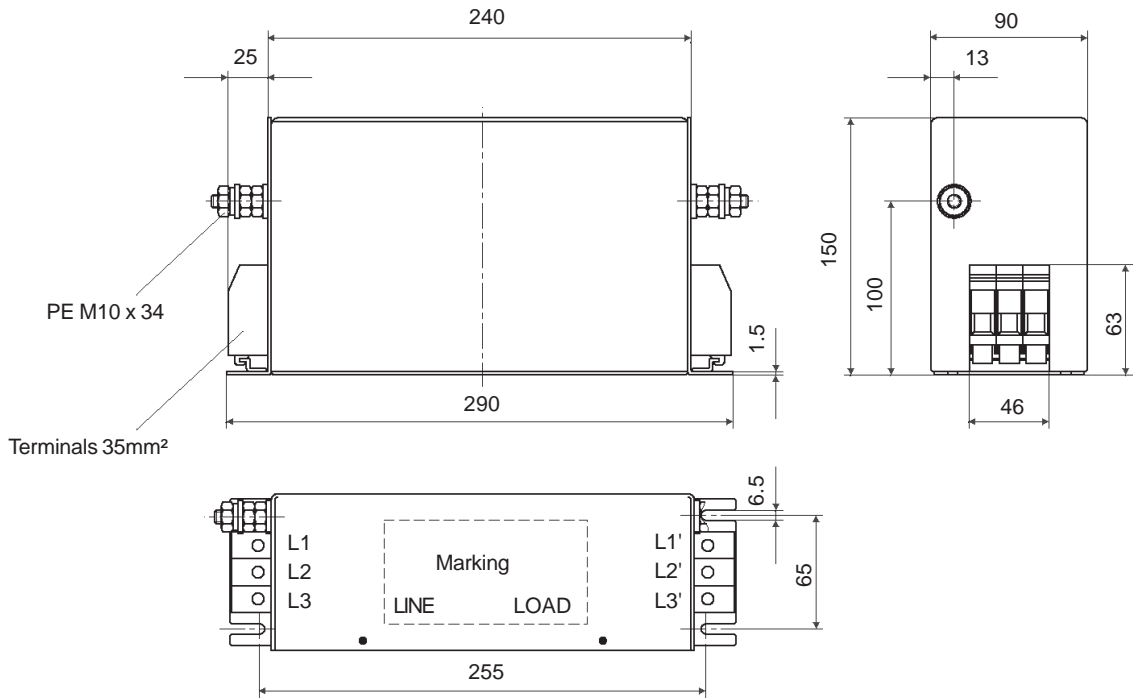

Figure 3.20 e) f) - EMC filters for CFW-09 inverter series [dimensions in mm]

g) EPCOS B84143A120R105 Filter



h) EPCOS B84143G150R110 Filter

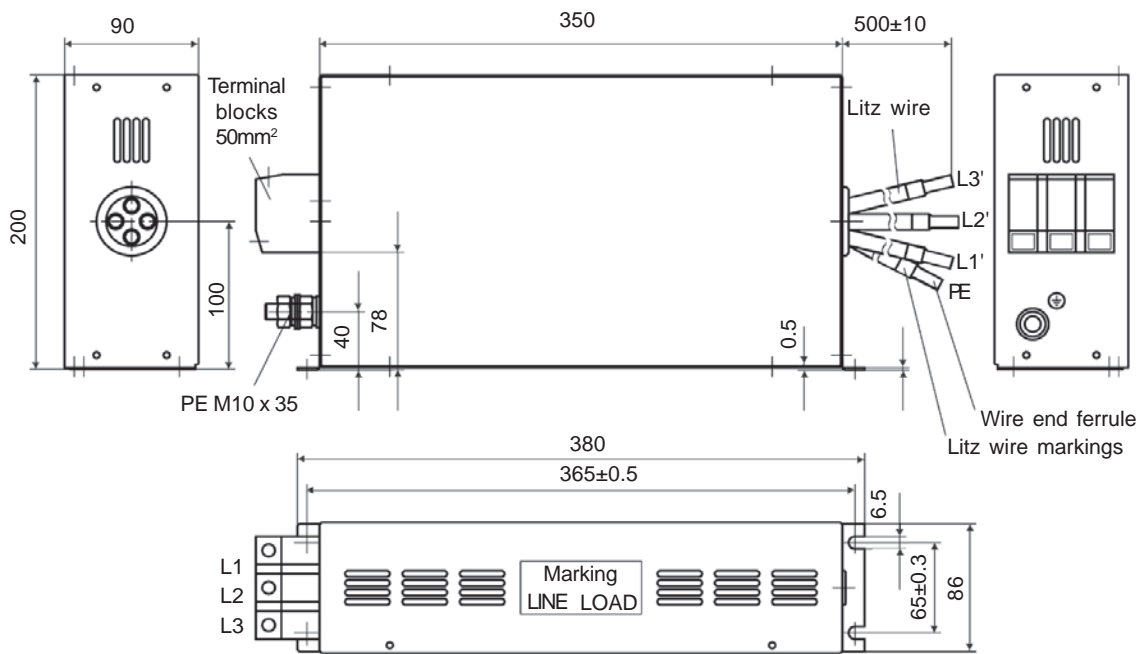
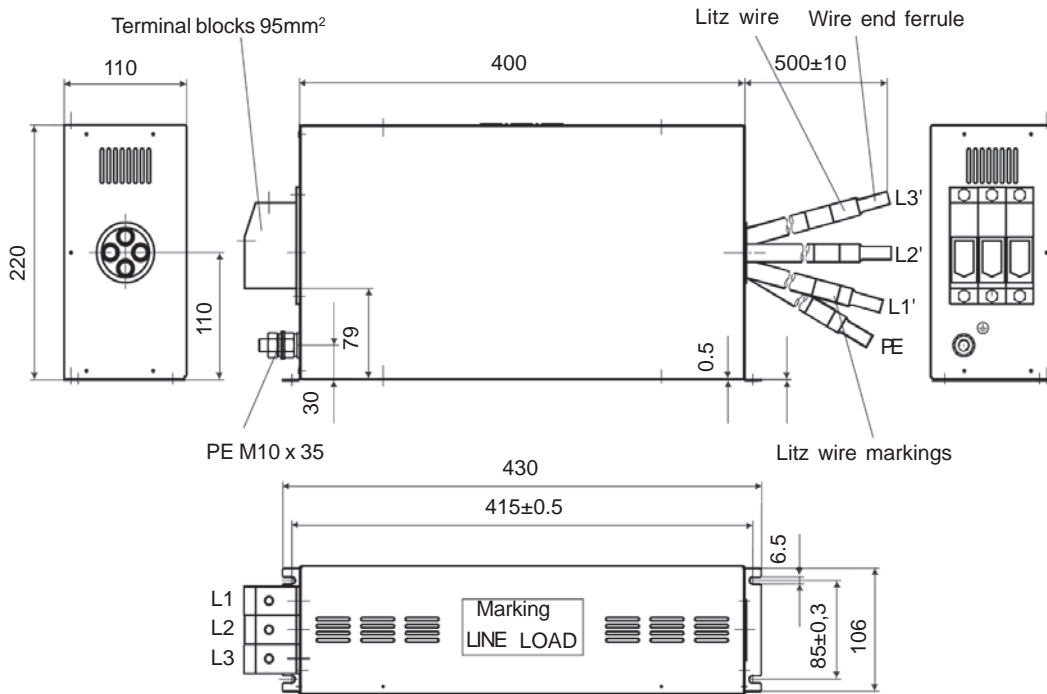

Figure 3.20 g) h) - EMC filters for CFW-09 inverter series [dimensions in mm]

## CHAPTER 3 - INSTALLATION

### i) EPCOS B84143G220R110 Filter



### j) EPCOS B84143B320S20 and B84143B400S20 Filters

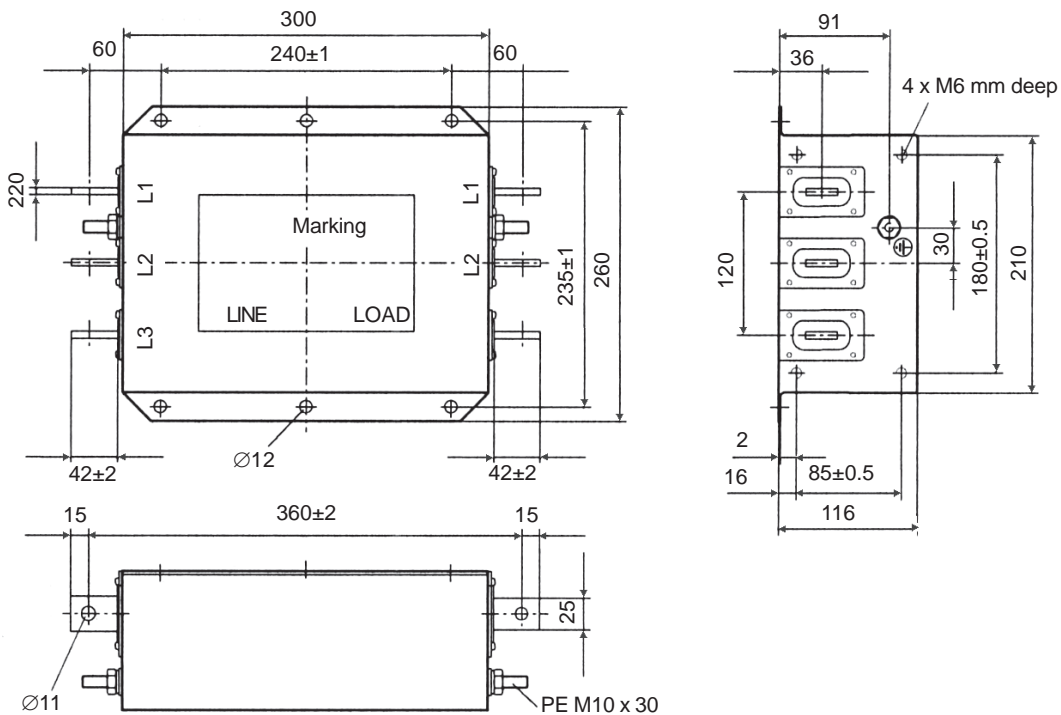
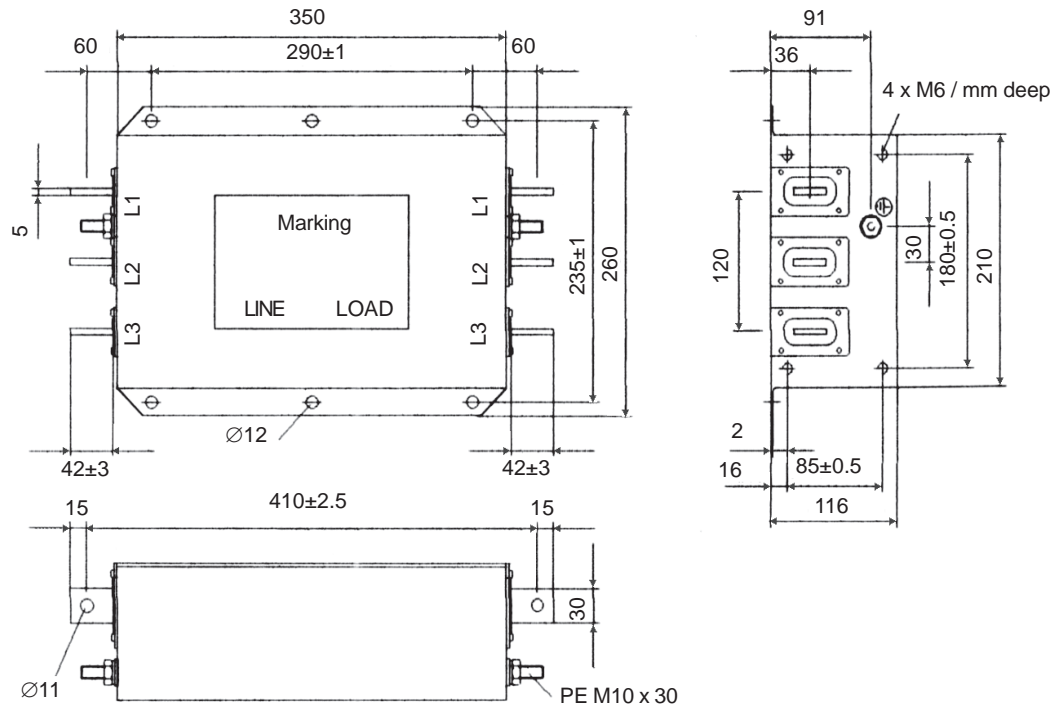

Figure 3.20 i) j) - EMC filters for CFW-09 inverter series [dimensions in mm]

k) EPCOS B84143B600S20 Filter



l) EPCOS B84143B1000S20 Filter

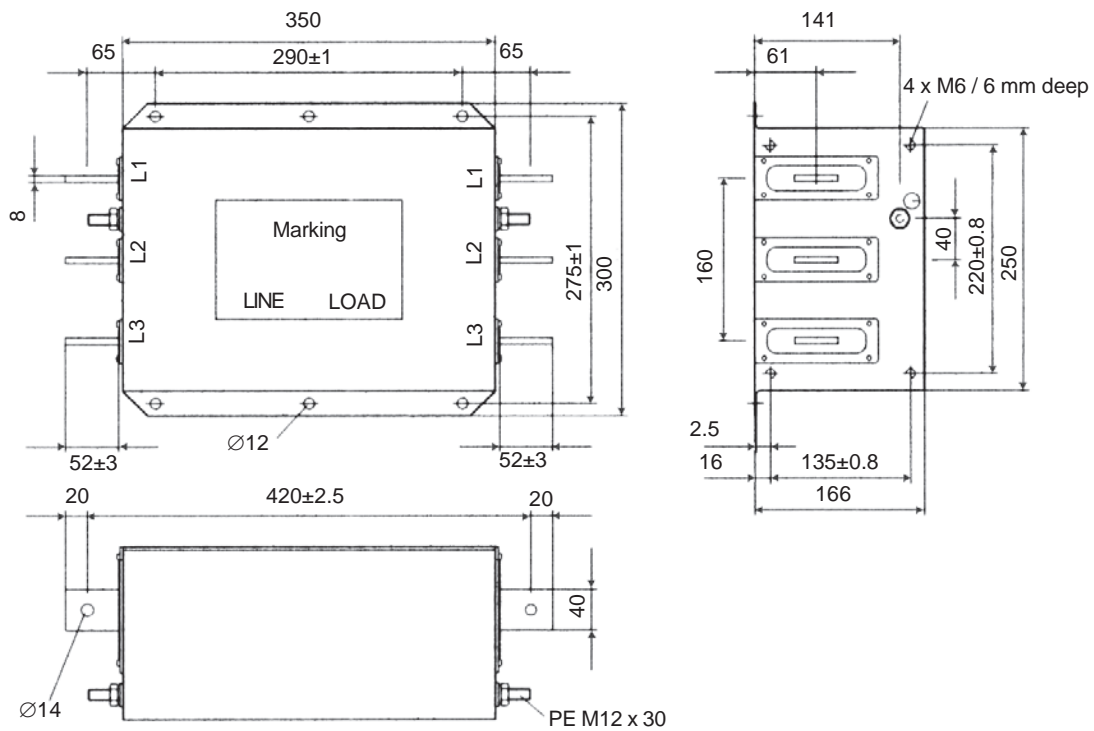
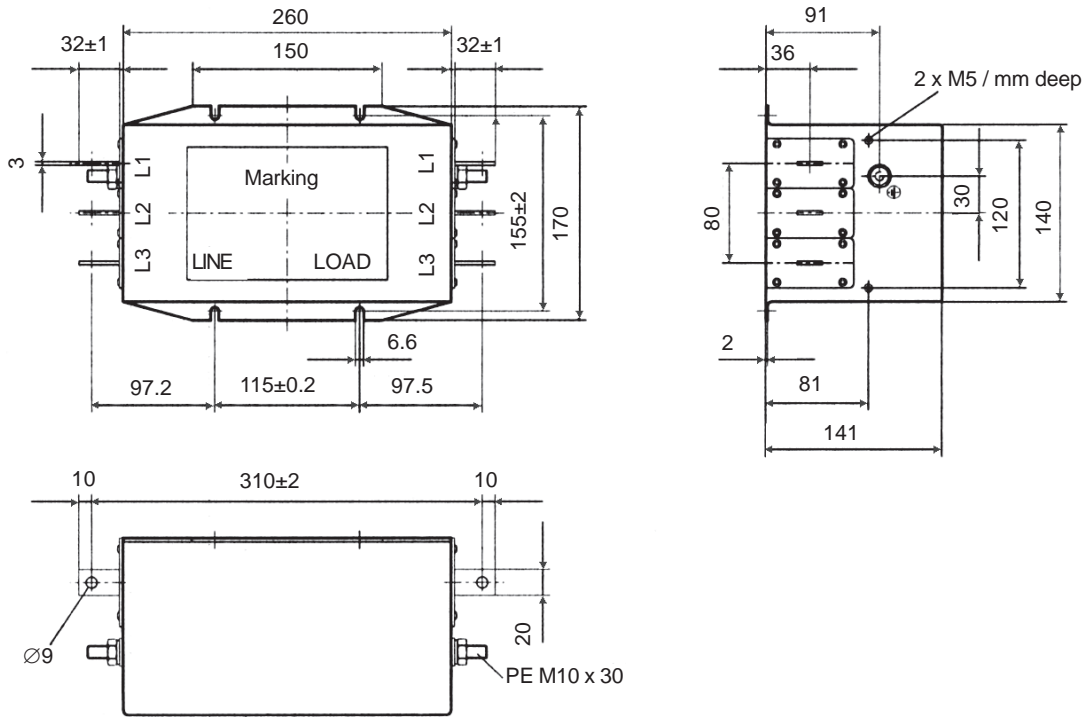

Figure 3.20 k) l) - EMC filters for CFW-09 inverter series [dimensions in mm]

## CHAPTER 3 - INSTALLATION

m) EPCOS B84143B150S21 and B84143B180S21 Filters



n) Filtro EPCOS B84143B250S21

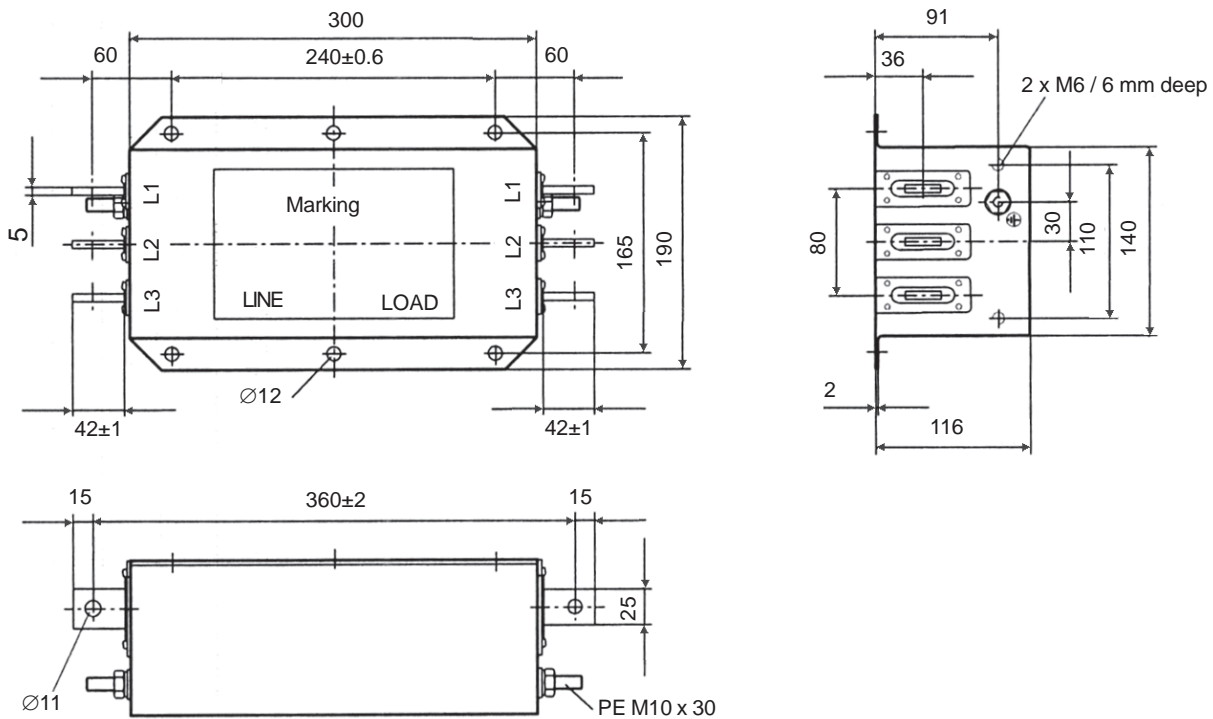

Figure 3.20 m) n) - EMC filters for CFW-09 inverter series [dimensions in mm]

o) EPCOS B84143B400S125 Filter

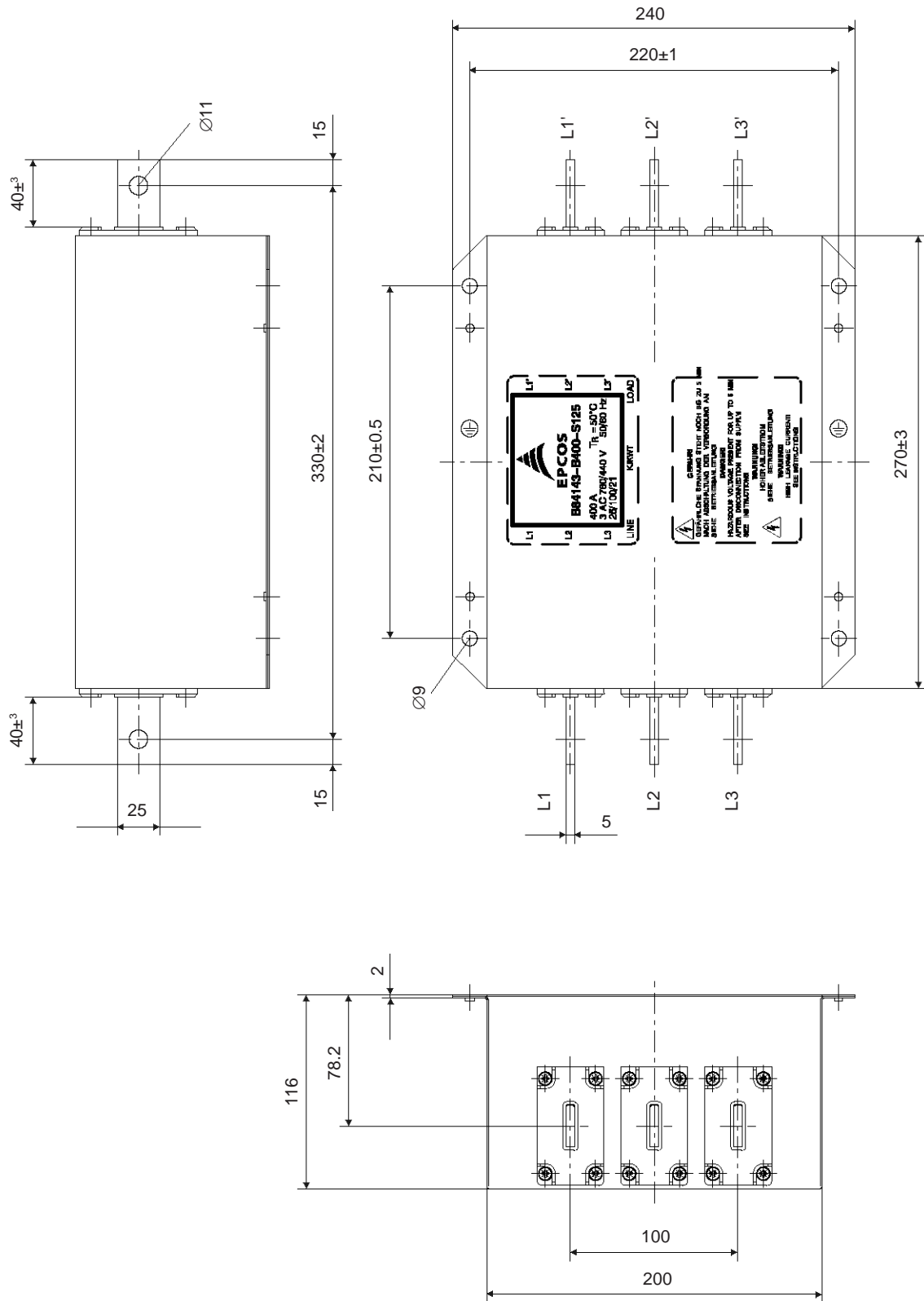

Figure 3.20 o) - EMC filters for CFW-09 inverter series [dimensions in mm]

p) EPCOS B84143B600S125 Filter

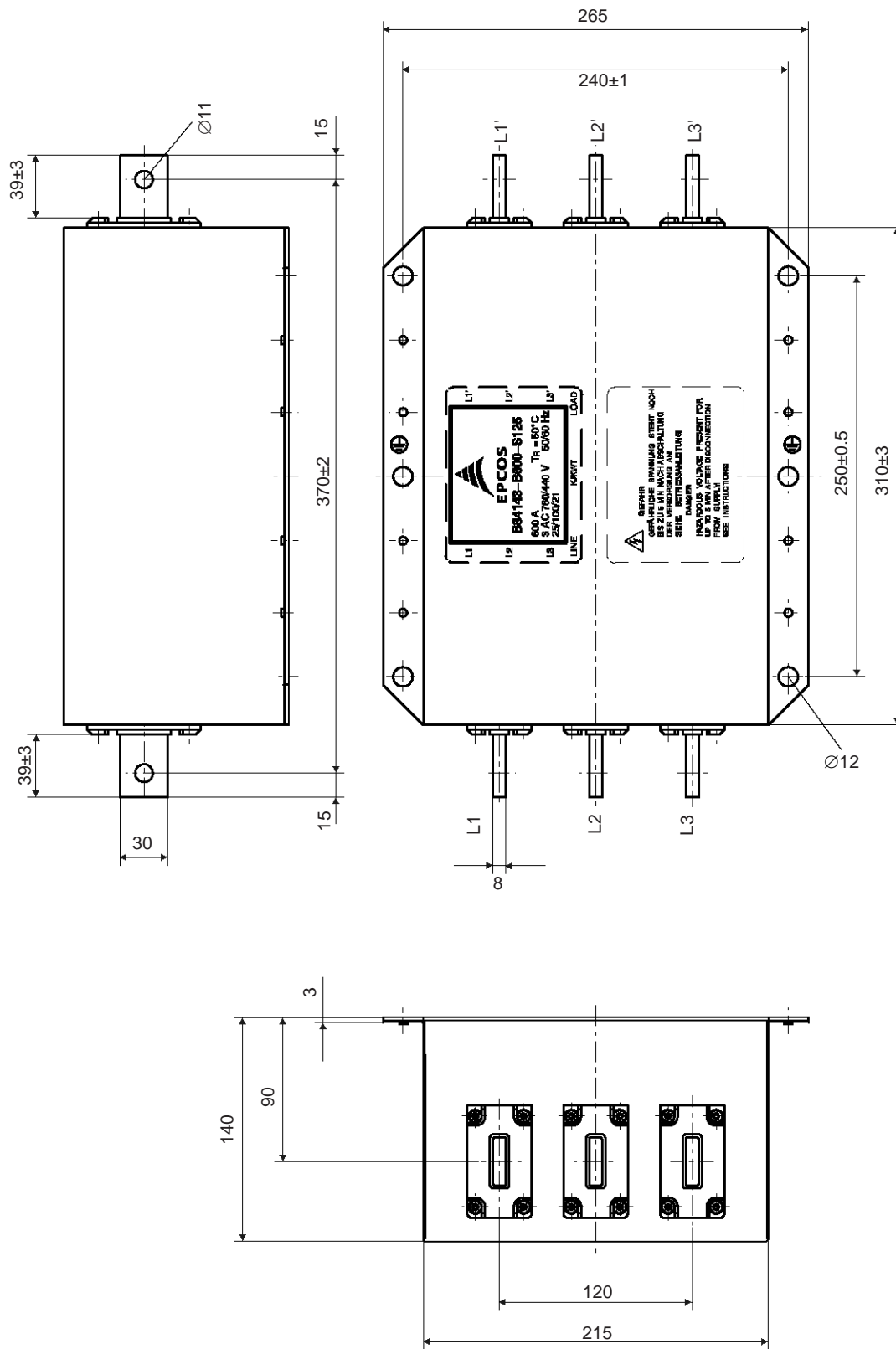
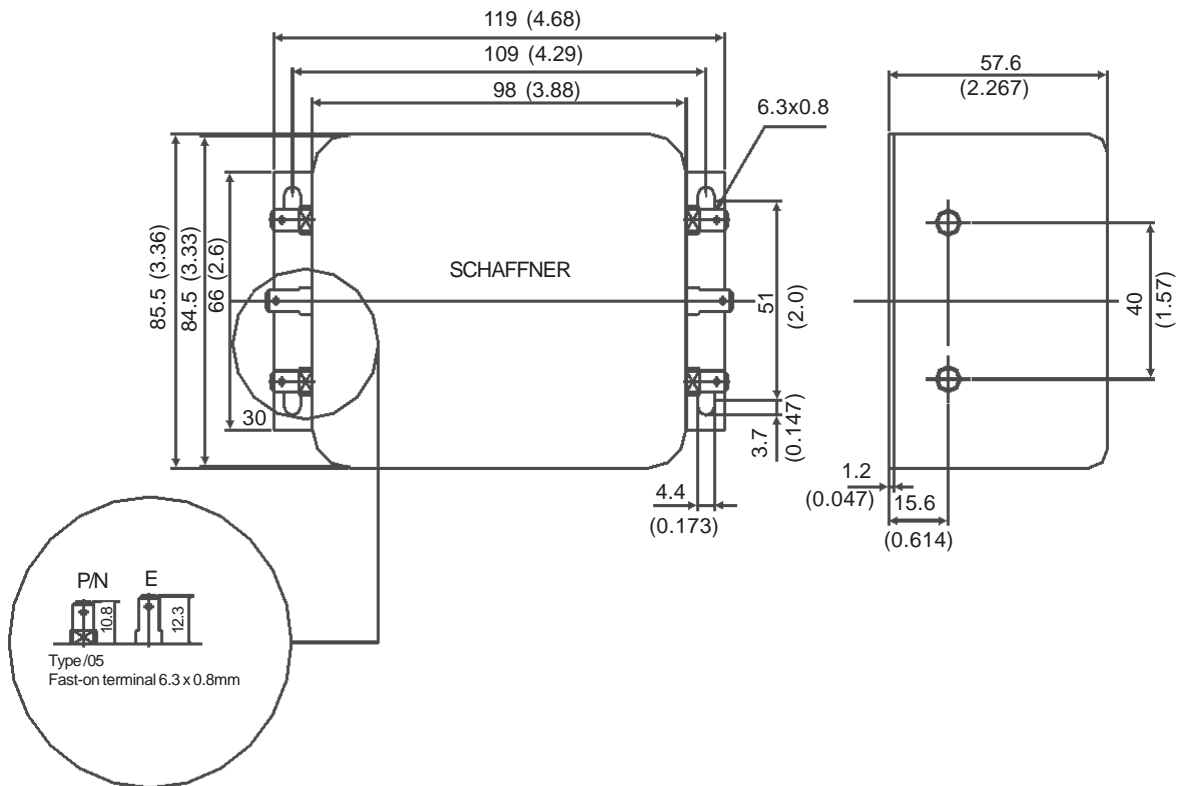

Figure 3.20 p) - EMC filters for CFW-09 inverter series [dimensions in mm]

q) Schaffner FS6007-16-06 Filter



r) Schaffner FS6007-25-08 and FS6007-36-08 Filter

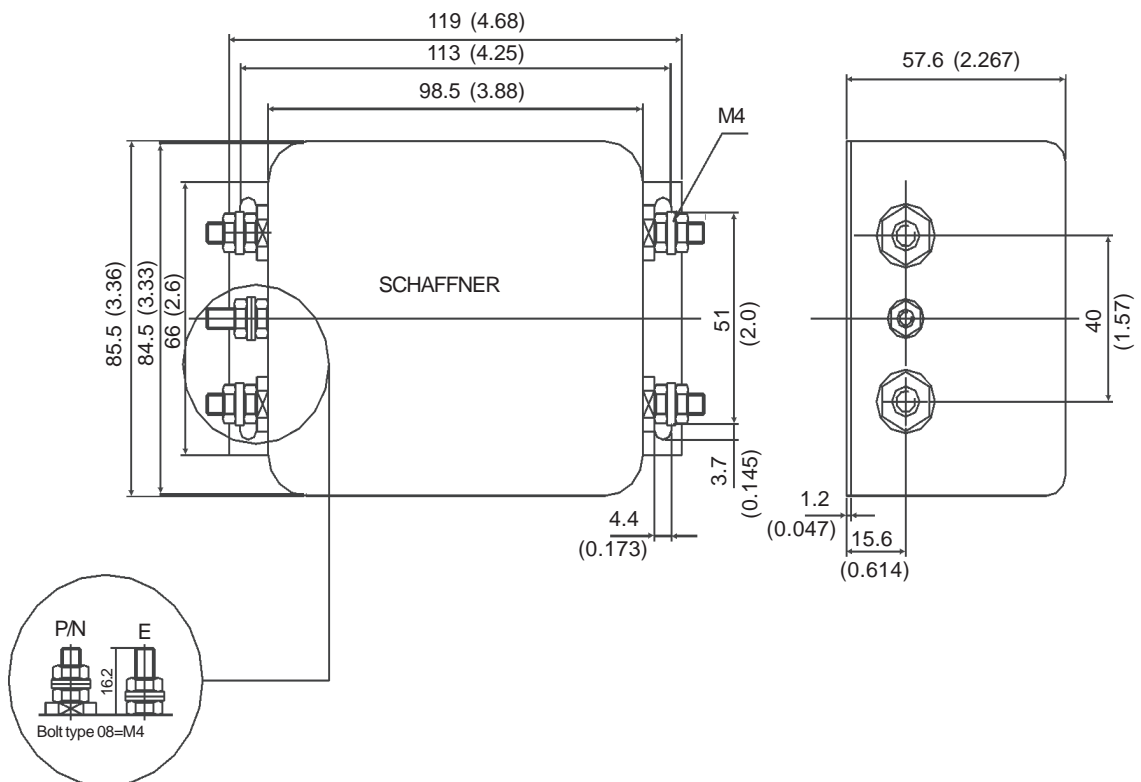
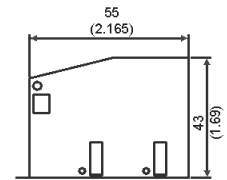
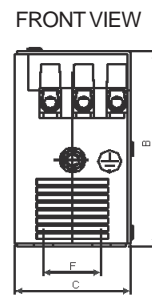
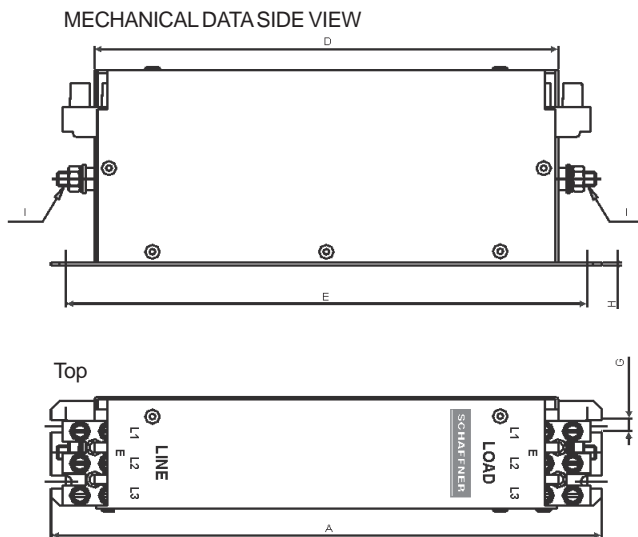

Figure 3.20 q) r) - EMC filters for CFW-09 inverter series [dimensions in mm (in)]

## CHAPTER 3 - INSTALLATION

s) Schaffner FN3258-7-45, FN3258-16-45, FN3258-30-47, FN3258-55-52, FN3258-100-35 and FN3258-130-35 filters

	Rated Current					
	7A	16A	30A	55A	100A	130A
A	190	250	270	250	270	270
B	70±0.6		85	90	150±1	
C	40	45	50	85	90±0.8	
D	160	220	240	220	240	
E	180	235	255	235	255	
F	20	25	30	60	65	
G	4.5	5.4	5.4	5.4	6.5	
H	1				1,5±0,2	
I	M5		M6	M10		
Connector	/45	/47	/52	/35	/35	



Type/35 - Terminal block for flexible and rigid cable of 50mm<sup>2</sup> or AWG 1/0. Max.Torque : 8Nm

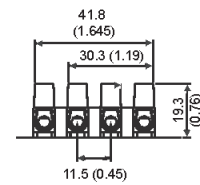

Type/45 - Terminal block for 6mm<sup>2</sup> solid cable, 4mm<sup>2</sup> flexible cable AWG 12.

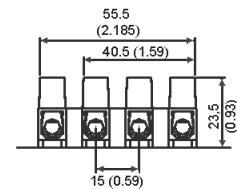

Type/47 - Terminal block for 16mm<sup>2</sup> solid wires, 10mm<sup>2</sup> flexible wires AWG 8.

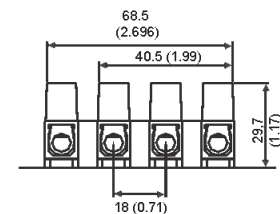

Type/52 - Dimensions in mm (inch) Terminal block for 25mm<sup>2</sup> solid wires, 16mm<sup>2</sup> flexible wires AWG 6.

Figure 3.20 s) - EMC filters for CFW-09 inverter series [dimensions in mm (in)]

t) Schaffner FN3359-150-28, FN3359-250-28, FN3359-400-99, FN3359-600-99 and FN3359-1000-99 filters

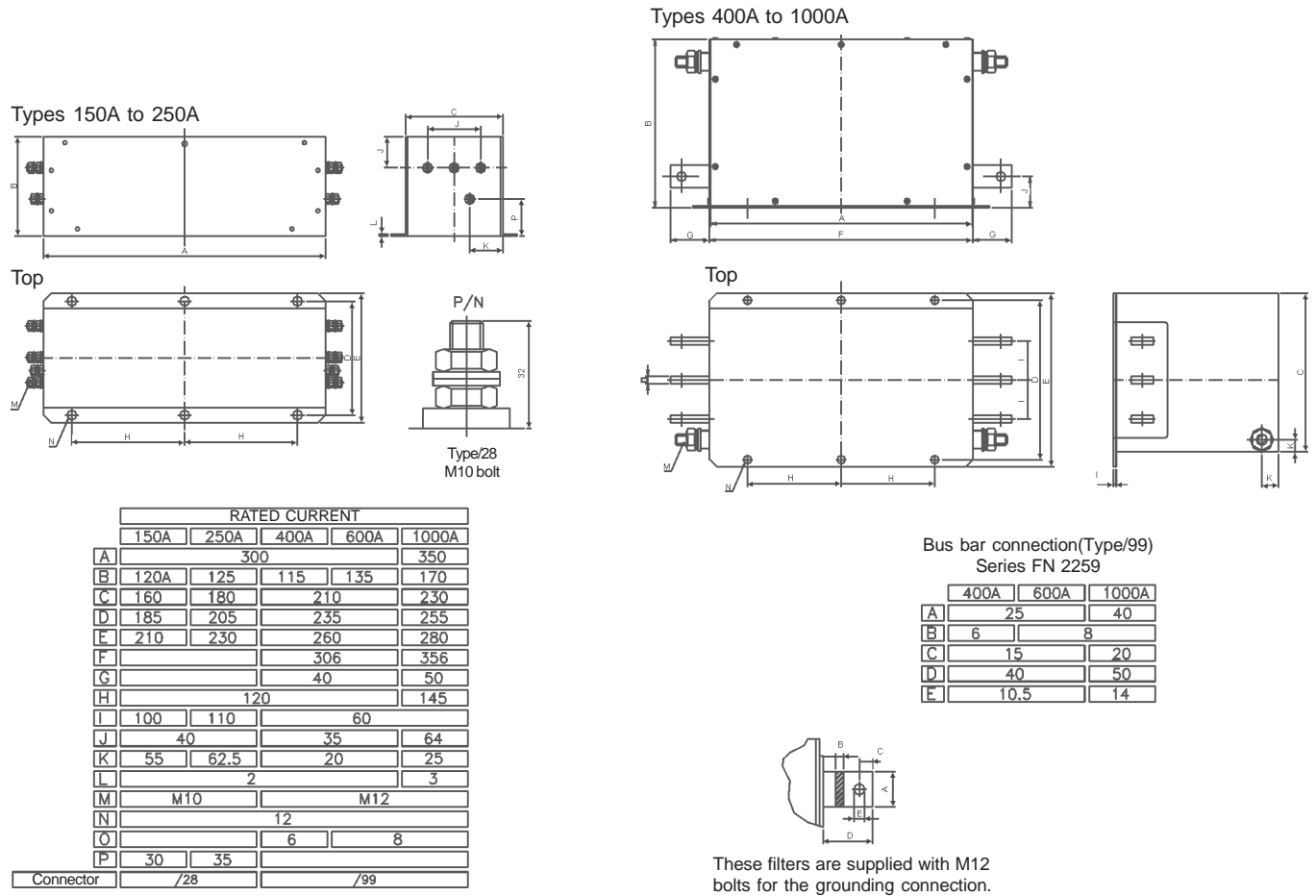

Figure 3.20 t) – EMC filters for CFW-09 inverter series [dimensions in mm]



# Declaration of Conformity

The undersigned, representing  
the manufacturer:

Weg Indústrias S/A - Automação  
Rua Waldemar Grubba, 3000  
89256900 Jaraguá do Sul - SC - Brazil

and our representative established within the European Community:

WEG France  
Parc Saint Quentin - Rue du Morellon  
38070 - Saint Quentin Fallavier - France

herewith declare under our sole responsibility that the product:

## **CFW-09 Frequency Inverter Series, models identified as below**

**CFW09 ... T 2223 ...**  
**CFW09 ... T 3848 ...**  
**CFW09 ... T 5069 ...**  
**CFW09 ... T 6669 ...**

to which this declaration relates, is in conformity with the requirements of the following directives when selected, installed and used according to the product documentation:

Low-Voltage Directive (LVD) 73/23/EEC including amendment 93/68/EEC;  
EMC Directive 89/336/EEC including amendment 92/31/EEC and 93/68/EEC.

The following standards have been applied:

Safety:

EN 50178 (1997) - Electronic equipment for use in power installations  
EN 60204-1 (1997) - Safety of machinery - Electrical equipment of machines -  
Part 1: General requirements

EMC:

EN 61800-3 (1996) and amendment A11 (2000) - Adjustable speed electrical power drive  
systems - Part 3: EMC product standard including test methods.

Year of CE Marking: 2001 for CFW09 ... T 2223 ... and CFW09 ... T 3848 ... models;  
2005 for CFW09 ... T 5069 ... and CFW09 ... T 6669 ... models.

Umberto Gobato  
Managing Director  
WEG Indústrias S/A - Automação  
Date: 09/02/2005

Wilmar Henning  
Director  
WEG France  
Date: 11/02/2005

## KEYPAD (HMI) OPERATION

This Chapter describes the CFW-09 operation via the standard Keypad or Human-Machine Interface (HMI), providing the following information:

- ☑ General Keypad Description;
- ☑ Use of the Keypad;
- ☑ Parameter Programming;
- ☑ Description of the Status Indicators.

### 4.1 DESCRIPTION OF THE KEYPAD

The standard CFW-09 Keypad has two readout displays: a LED readout with a 4 digit, seven-segment display and a LCD display with two lines of 16 alphanumeric characters. There are also 4 indicator LED's and 8 keys. Figure 4.1 shows the front view of the Keypad and indicates the position of the readouts, keys and status LED's.

#### Functions of the LED Display:

The LED Display shows the fault codes, drive status, the parameter number and its value. For units of current, voltage or frequency, the LED display shows the unit in the right side digit (L.S.D.) as shown here.

- A → current (A)
- U → voltage (volts)
- H → frequency (Hertz)
- Blank → speed and other parameters



#### NOTE!

When the indication is higher than 9999 (for instance in rpm) the number corresponding to the ten of thousand will not be displayed (ex.: 12345 rpm will be read as 2345 rpm). The correct indication will be displayed only on the LCD display.

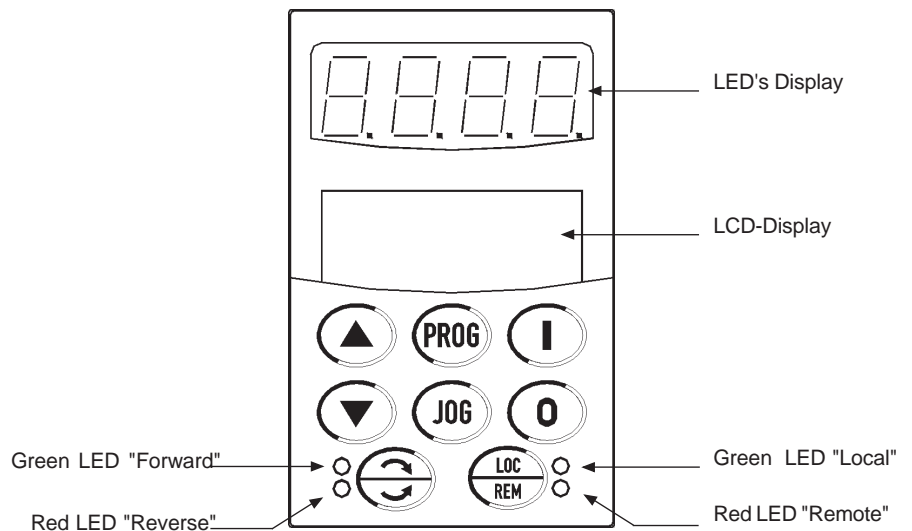



Figure 4.1 - CFW-09 Standard Keypad

#### Functions of the LCD Display:

The LCD Display shows the parameter number and its value simultaneously, without requiring the toggling of the  key. It also provides a brief description of each parameter function, fault code and inverter status.

**LOCAL and REMOTE LED's:**

Inverter in Local Mode:  
Green LED ON and Red LED OFF.

Inverter in Remote Mode:  
Green LED OFF and Red LED ON.

**Direction of Rotation (FWD/REV) LED's:**

Refer to Figure 4.2 below.

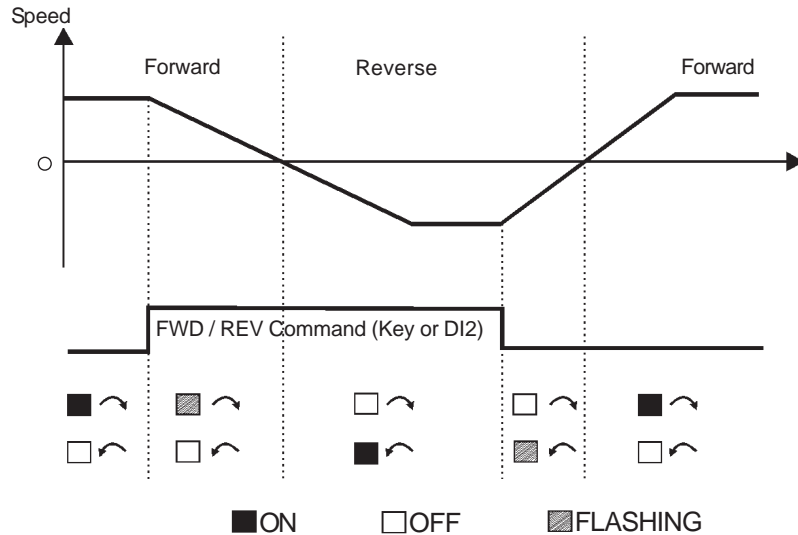
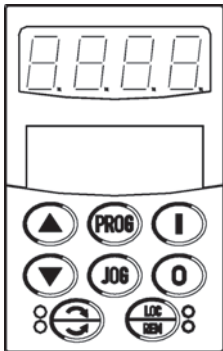

Figure 4.2 - Direction of Rotation (FWD / REV) LED's



**Basic Functions of the Keys:**

The functions described below are valid for factory default programming and Local Mode operation. The actual function of the keys may vary if parameters P220 through P228 are re-programmed.

- Starts the inverter via the acceleration ramp. After starting, the display sequences through these units at each touch of the Start key in the order shown here (see item 4.2.2 a):  

rpm → Volts → Status → Torque → % → Hz → A
- Stops (disables) the inverter via the deceleration ramp. Also resets the inverter after a fault has occurred.
- Toggles the LED display between the parameter number and its value (Number/Value).
- Increases the speed, the parameter number or the parameter value.
- Decreases the speed, the parameter number or the parameter value.
- Reverses the direction of motor rotation between Forward/Reverse.
- Toggles between the LOCAL and REMOTE modes of operation.
- Performs the JOG function when pressed.  
 Any DIx programmed for General Enable must be closed (and the CFW-09 must be stopped) to enable JOG function.

## 4.2 USE OF THE KEYPAD (HMI)

The keypad is used for programming and operating the CFW-09 allowing the following functions:

- ☑ Indication of the inverter status and operation variables;
- ☑ Fault Indication and Diagnostics;
- ☑ Viewing and programming parameters;
- ☑ Operation.

### 4.2.1 Keypad Operation

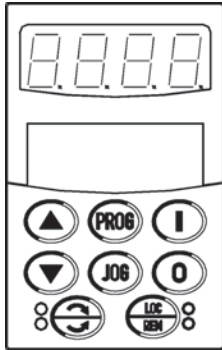

All functions relating to the CFW-09 operation (Start, Stop, Motor Direction of Rotation, JOG, Increment/Decrement of the Speed Reference and Selection of Local Mode/Remote Mode) can be performed through the Keypad. This is valid with the factory default programming of the inverter. All keypad keys are enabled when the Local Mode has been selected. These same functions can be performed in Remote Mode by means of digital and analog inputs. Flexibility is provided through the ability to program the parameters that define the input and output functions.

#### Keypad keys operation description:

Both **I** and **O** keys are enabled when P224 = 0 (I, O Key) for Local Mode and/or P227 = 0 (I,O Key) for Remote Mode.

- I** Starts the inverter via the Acceleration Ramp.
- O** Stops the inverter via Deceleration Ramp.

#### NOTE!

It resets the inverter after a Fault Trip (always active).

- JOG** When the Jog key is pressed, it accelerates the motor according to the Acceleration Ramp up to the JOG speed programmed in P122 (default is 150 rpm). When released, the motor decelerates according to the Deceleration Ramp and stops.  
Enabled when P225 = 1 (Keypad) for Local Mode and/or P228 = 1 (Keypad) for Remote Mode.  
If a Digital Input is set to General Enable (P263 to P270 = 2) it has to be closed to allow the JOG function.
- LOC/REM** Selects the control input and speed reference source, toggling between LOCAL Mode and REMOTE Mode.  
Enabled when P220 = 2 (Keypad LOC) or 3 (Keypad REM).
- REV** Reverses the motor direction of rotation.  
Enabled when P223 = 2 (Keypad FWD) or 3 (Keypad REV) for Local Mode and/or P226 = 2 (Keypad FWD) or 3 (Keypad REV) for Remote Mode.

The keys described below are enabled when P221 = 0 (Keypad) for Local Mode and/or P222 = 0 (Keypad) for Remote Mode. The parameter P121 contains the speed reference set by the keypad.

- ▲** When pressed it increases the speed reference.
- ▼** When pressed it decreases the speed reference.



**NOTE!**

**Reference Backup**

The last frequency Reference set by the keys and is stored when the inverter is stopped or the AC power is removed, provided P120 = 1 (Reference Backup active is the factory default). To change the frequency reference before starting the inverter, the value of parameter P121 must be changed.

4.2.2 “Read-Only” Variables and Status

Parameters P002 to P099 are reserved for the display of “read-only” values. The factory default display when power is applied to the inverter is P002. Motor speed in rpm. The user can scroll through the various read-only parameters or use the factory configured display of the key values. This is done by pressing the start key .

a) Some selected “read-only” variables can be viewed following the procedure below:

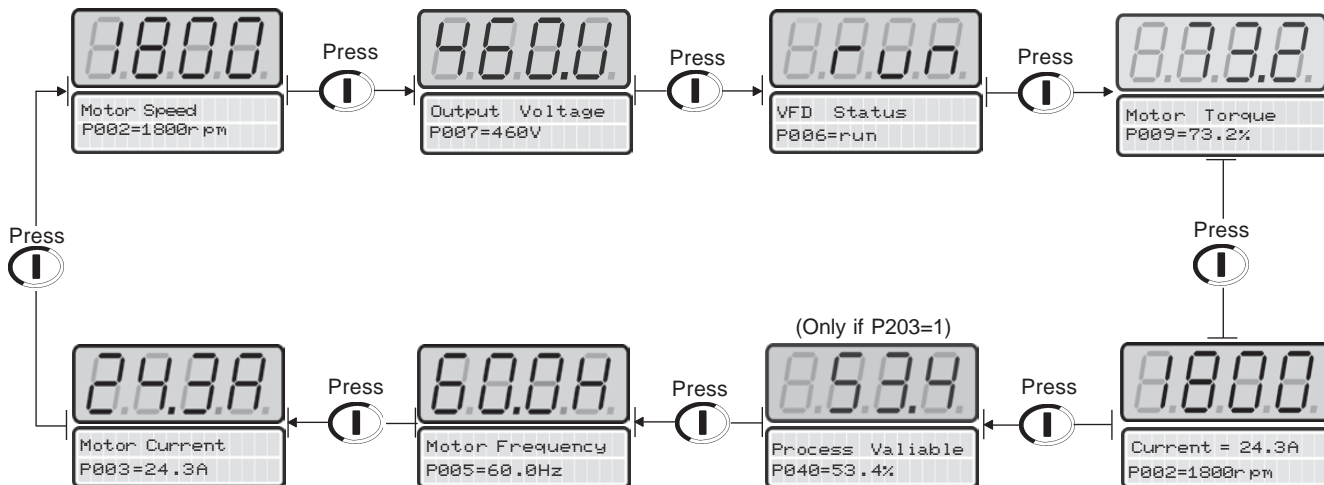

The “read-only” variable to be shown after AC power is applied to the inverter is defined in Parameter P205:

P205	Initial Monitoring Parameter
0	P005 (Motor Frequency)
1	P003 (Motor Current)
2	P002 (Motor Speed)
3	P007 (Output Voltage)
4	P006 (Inverter Status)
5	P009 (Motor Torque)
6	P070 (motor speed and motor current)
7	P040 (PID process variable)

*Table 4.1 - Choosing the initial monitoring parameter*

b) Inverter Status:



Inverter is READY to be started  
(No Fault condition)



Inverter has been started  
(Run condition)



Line voltage is too low for inverter operation  
(Undervoltage condition)



c) LED display flashing:

The display flashes in the following conditions:

- During the DC Injection braking;
- Trying to change a parameter value when it is not allowed;
- Inverter in a current overload condition (Refer to Chapter 7 - Diagnostics and Troubleshooting);
- Inverter in Fault condition (Refer to Chapter 7 - Diagnostics and Troubleshooting).

### 4.2.3 Parameter Viewing and Programming

All CFW-09 settings are made through the parameters. The parameters are shown on the display with the letter **P** followed by a number.

Example (P101):





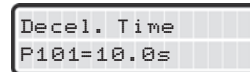









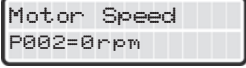

**101 = Parameter Number**

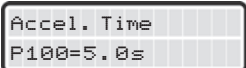

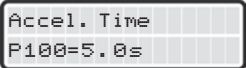
Each parameter is associated to a numerical value (parameter content), that corresponds to an option selected among those options that are available for this parameters.

The values of the parameters define the inverter programming or the value of a variable (e.g. current, frequency, voltage). For inverter programming you should change the parameter content(s).

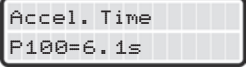
To allow the reprogramming of any parameter value it is required to change parameter P000 to the password value. The factory default password value is 5. Otherwise you can only read the parameter values and not reprogram them. For more detail see P000 description in Chapter 6.

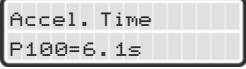
ACTION	LED DISPLAY	Comments
	LCD DISPLAY	
Press the  key	 	
Use the  and  keys to reach P100	 	Select the desired parameter
Press the  key	 	Numeric value associated to the parameter <sup>(4)</sup>
Use the  and  keys to set the new value	 	Sets the new desired value. (1) (4)
Press the  key	 	(1) (2) (3)



**NOTES:**

**(1)** For parameters that can be changed with the motor running, the inverter will use the new value immediately after it has been set. For the parameters that can be changed only with motor stopped, the inverter will use this new set value only after the  key is pressed.

**(2)** By pressing the  key after the reprogramming, the new programmed value will be stored automatically and will remain stored until a new value is programmed.

**(3)** If the last value programmed in the parameter is not functionally compatible with other parameter values already programmed, an E24 - Programming Error - will be displayed.

Example of programming error:

Programming two digital inputs (DIx) with the same function. Refer to Table 4.2 for the list of programming errors that will generate an E24 Programming Error.

(4) To allow the reprogramming of any parameter value it is required to change parameter P000 to the password value. The factory default password value is 5. Otherwise you can only read the parameter values and not reprogram them. For more detail see P000 description in Chapter 6.

**E24 - Incompatibility between parameters**

1)	Two or more parameters between P264 or P265 or P266 or P267 or P268 or P269 and P270 equal to 1 (LOC/REM).
2)	Two or more parameters between P265 or P266 or P267 or P268 or P269 and P270 equal to 6 (Ramp 2).
3)	Two or more parameters between P265 or P266 or P267 or P268 or P269 and P270 equal to 9 (Speed/Torque).
4)	P265 equal to 8 and P266 different than 8 or vice versa (FWD Run / REV Run).
5)	P221 or P222 equal to 8 (Multispeed) and P266 ≠ 7 and P267 ≠ 7 and P268 ≠ 7.
6)	[P221=7 or P222=7] and [(P265 ≠ 5 and P267 ≠ 5) or (P266 ≠ 5 and P268 ≠ 5)]. (with reference=EP and without Dlx=increase EP or without Dlx=decrease EP).
7)	P264 and P266 equal to 8 (Reverse Run).
8)	[P221 ≠ 7 and P222 ≠ 7] and [(P265=5 or P267=5 or P266=5 or P268=5)]. (without reference=EP and with Dlx=increase EP or with Dlx=decrease EP).
9)	P265 or P267 or P269 equal to 14 and P266 and P268 and P270 different than 14 (with Dlx=Start and Dlx ≠ Stop).
10)	P266 or P268 or P270 equal to 14 and P265 and P267 and P269 different than 14 (with Dlx ≠ Start and Dlx=Stop).
11)	P220 > 1 and P224 = P227 = 1 without any Dlx set for Start/Stop or Dlx = Fast Stop or General Enable.
12)	P220 = 0 and P224 = 1 and without Dlx = Start/Stop or Fast Stop and without Dlx = General Enable.
13)	P220 = 1 and P227 = 1 and without Dlx = Start/Stop or Fast Stop and without Dlx = General Enable.
14)	Dlx = START and Dlx = STOP, but P224 ≠ 1 and P227 ≠ 1.
15)	Two or more parameters between P265 or P266 or P267 or P268 or P269 and P270 equal to 15 (MAN/AUT).
16)	Two or more parameters between P265 or P266 or P267 or P268 or P269 and P270 equal to 17 (Disables Flying-Start).
17)	Two or more parameters between P265 or P266 or P267 or P268 or P269 and P270 equal to 18 (DC Voltage Regulator).
18)	Two or more parameters between P265 or P266 or P267 or P268 or P269 and P270 equal to 19 (Parameter Setting Disable).
19)	Two or more parameters between P265, P266, P267, P268 and P269 equal to 20 (Load user via Dlx).
20)	P296=8 and P295=4, 6, 39, 40, 41, 42, 43, 44, 45, 46, 47, 48, or 49 (P295 incompatible with inverter model – To avoid damages of the internal inverter components).
21)	P296=5, 6, 7 or 8 and P297=3 (P297 incompatible with inverter model).
22)	Two or more parameters between P265 or P266 or P267 or P268 or P269 and P270 equal to 21 (Timer RL2).
23)	Two or more parameters between P265 or P266 or P267 or P268 or P269 and P270 equal to 22 (Timer RL3).
24)	P265 or P266 or P267 or P268 or P269 or P270=21 and P279 ≠ 28.
25)	P265 or P266 or P267 or P268 or P269 or P270=22 and P280 ≠ 28.
26)	P279=28 and P265 or P266 or P267 or P268 or P269 or P270 ≠ 21.
27)	P280=28 and P265 or P266 or P267 or P268 or P269 or P270 ≠ 22.
28)	P202 ≤ 2 and P237=1 or P241=1 or P265 to P270=JOG+ or P265 to P270=JOG-.
29)	P203=1 and P211=1 and [P224=0 or P227=0]
30)	P220=0 and P224=1 and P227=0 or P227=1 and P263=0
31)	P220=1 and P224=0 or P224=1 and P227=1 and P263=0
32)	P220=2 and P224=0 or P224=1 and P227=0 or P227=1 and P263=0

**Table 4.2 - Incompatibility between Parameters - E24**

5.1 PRE-POWER CHECKS

START-UP

This Chapter provides the following information:

- ☑ How to check and prepare the inverter before power-up;
- ☑ How to power-up and check for proper operation;
- ☑ How to operate the inverter.

The inverter shall be installed according to chapter 3: Installation.



**DANGER!**

Disconnect the AC input power before making any connections. Even when the drive project is different from the suggested connections, the following recommendations are applicable.

**1) Check all connections**

Check if the power, grounding and control connections are correct and well tightened.

**2) Clean the inside of the inverter**

Remove all shipping material from the inside of the inverter or cabinet.

**3) Check if the selected inverter AC power is correct (refer to section 3.2.3)**

**4) Check the motor**

Check all motor connections and verify if its voltage, current and frequency match the inverter specifications.



**NOTES!**

Operation in VT mode

When the motor data is set properly during the first power-up routine, the drive automatically sets the additional parameters used for the correct operation under this control mode.

**5) Uncouple the load from the motor**

If the motor cannot be uncoupled, make sure that the direction of rotation (FWD/REV) cannot cause damage to the machine.

**6) Close the inverter cover or cabinet doors**

After the inverter has been checked, AC power can be applied:

**1) Check the supply voltage**

Measure the line voltage and check if it is within the specified range (refer to section 9.1).

**2) Power-up the AC input**

Close the input circuit breaker or disconnect switch.

**3) Check if the power-up has been successful**

When the inverter is powered up for the first time or when the factory default parameter values are loaded (P204 = 5), a start-up sub-routine is run. This sub-routine requests the user to program some basic parameters to ensure proper operation and motor protection.

A start-up programming example is shown below:

**Inverter**

Line: CFW-09  
 Rated Current: 9 A  
 Rated Voltage: 380V to 480 V  
 Model: CFW090009T3848ESZ  
 Cooling: Self-ventilated











**Motor**







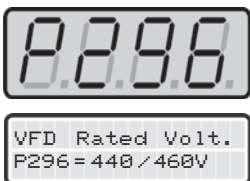

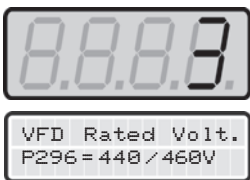



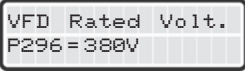

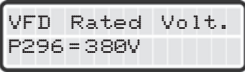







WEG IP55  
 Power: 5 HP  
 rpm: 1730, 4 POLE  
 Rated Current: 7.9 A  
 Rated Voltage: 460 V  
 Frequency: 60 Hz  
 Cooling: Self-ventilated









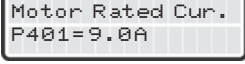



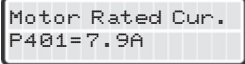

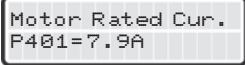





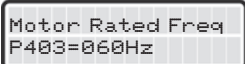

5.2 INITIAL POWER-UP

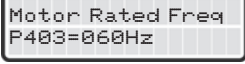

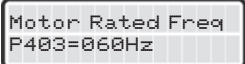

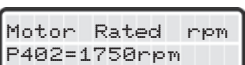

















ORIENTED START-UP



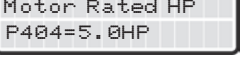

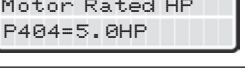

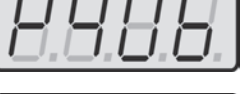
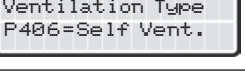
Initial Power-up - Programming via Keypad (HMI) (Based on the example above):

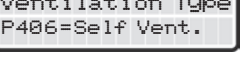
ACTION	LED DISPLAY LCD DISPLAY	DESCRIPTION
After power-up, the display shows the following message		Language Selection: 0=Português 1=English 2=Español 3=German
Press the  key to enter the programming mode		Enter the programming mode
Use the  and  keys to select the language		Selected Language: 1 = English
Press the  key to save the selected option and exit the programming mode		Exit the programming mode.
Press the key  to go to the next parameter		Inverter Rated Voltage Selection: 0=220V/230V 1=380V 2=400V/415V 3=440V/460V 4=480V 5=500V/525V 6=550/575V 7=600V 8=660V/690V
Press the  key to enter the programming mode		Enter the programming mode

ACTION	LED DISPLAY LCD DISPLAY	DESCRIPTION
Use the  and  keys to select the inverter power supply voltage.	 	Selected Inverter Rated Voltage: 1 = 380V
Press the  key to save the selected option and exit the programming mode	 	Exit the programming mode.
Press the  key to go to the next parameter.	 	Motor Rated Voltage: 0 to 690V
Press the  key to enter the programming mode	 	Enter the programming mode
Use the  and  keys to set the correct motor rated voltage value	 	Programmed Motor Rated Voltage: 380V
Press the  key to save the programmed value and exit the programming mode	 	Exit the programming mode.
Press the  key to go to the next parameter	 	Motor Rated Current Range: (0.0 to 1.30) x P295 <sup>(1)</sup>
Press the  key to enter the programming mode.	 	Enter the programming mode

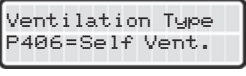
ACTION	LED DISPLAY LCD DISPLAY	DESCRIPTION
Use the  and  keys to set the correct motor rated current value	 	Programmed Motor Rated Current: 7.9 A
Press the  key to save the programmed value and exit the programming mode	 	Exit the programming mode.
Press the  key to go to the next parameter	 	Motor Rated Frequency Range: 0 to 300Hz
Press the  key to enter the programming mode	 	Enter the programming mode
Use the  and  keys to set the correct motor rated frequency value	 	Programmed Motor Rated Frequency: 60 Hz
Press the  key to save the programmed value and exit the programming mode	 	Exit the programming mode.
Press the  key to go to the next parameter	 	Motor Rated rpm Range: 0 to 18000 rpm
Press the  key to enter the programming mode	 	Enter the programming mode

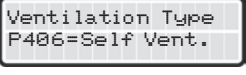
ACTION	LED DISPLAY LCD DISPLAY	DESCRIPTION
Use the  and  keys to set the correct motor rated rpm value	 	Programmed Motor Rated rpm: 1730 rpm
Press the  key to save the programmed value and exit the programming mode	 	Exit the programming mode.
Press the  key to go to the next parameter	 	Motor Rated HP Range: 1 to 1600.0 HP 1 to 1190.0 kW
Press the  key to enter the programming mode	 	Enter the programming mode
Use the  and  keys to select the motor rated power	 	Selected Motor Rated Power: 5.0 HP/3.7 kW
Press the  key to save the selected option and exit the programming mode.	 	Exit the programming mode.
Press the  key to go to the next parameter	 	Motor Ventilation Type Selection: 0=Self Ventilated 1=Separate Ventilation 3=Increased Protection
Press the  key to enter the programming mode	 	Enter the programming mode

ACTION	LED DISPLAY	DESCRIPTION
	LCD DISPLAY	
Use the  and  keys to select the motor ventilation type	 	Selected Motor Ventilation Type: 0 = Self Ventilated
Press the  key to save the selected option and exit the programming mode	 	Exit the programming mode.
Refer to Section 5.3	 	The first power-up routine is finished. Inverter is ready to operate.

Note: (1) P401 maximum value is 1.8xP295 for model 4.2A/500-600V and 1.6xP295 for models 7A and 54A/220-230V; 2.9A and 7A/500-600V; 107A, 147A and 247A/500-690V; 100A, 127A and 340A/660-690V.



**ATTENTION!**

Open the input circuit breaker or disconnect switch to shut down the CFW-09.



**NOTES!**

- To repeat the initial power-up procedure:  
Set the parameter **P204 = 5 or 6** (this loads the factory default parameters) and follow the initial power-up sub-routine again;
- The initial power-up sub-routine described above automatically sets some parameters according to the entered data. For more details, refer to Chapter 6.
- Modification of motor characteristics after the first power up:
  - a) Insert the motor data at parameters P400 to P407;
  - b) For operation in the vector mode run the self-tuning routine (P408 > 0);
  - c) Set P156, P157, P158, P169, P170, P171, and P172;
  - d) Power the drive down and up for the new settings to take place and for the proper motor operation.
- Modification of motor characteristics after the first power up, for operation in VT mode:  
Follow the previous procedures and also set parameter P297 to 2.5 kHz.

5.3 START-UP

This Section describes the start-up procedure when operating via the Keypad (HMI). Four types of control will be considered: **V/F 60Hz, Sensorless Vector, Vector with Encoder Feedback and VVW (Voltage Vector Weg).**



**DANGER!**

Even after the AC input is disconnected, high voltages may still be present. Wait at least 10 minutes after powering down to allow a full discharge of the capacitors.

5.3.1 Type of Control: V/F 60Hz - Operation Via Keypad (HMI)









The **V/F or Scalar** control is recommended in the following cases:



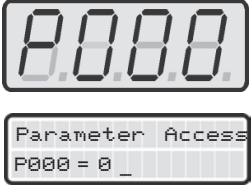
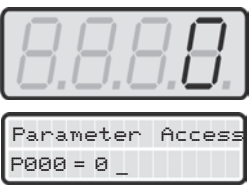

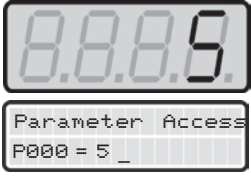







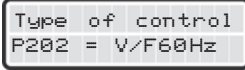



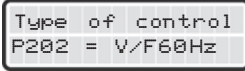

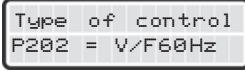





- Several motors driven by the same inverter;
- Motor rated current lower than 1/3 of the inverter rated current;
- For test purposes, without a motor connected to the inverter.









The V/F control can also be used in applications that do not require fast dynamic responses, accurate speed regulation or high starting torque (speed error will be a function of the motor slip).

When parameter **P138** (Rated Slip) is programmed, speed accuracy of 1% can be obtained.

The sequence below is valid for the Connection 1 (refer to section 3.2.7). The inverter must be already installed and powered up according to chapter 3 and section 5.2.



ACTION	LED DISPLAY LCD DISPLAY	DESCRIPTION
Power-up the inverter		Inverter is ready to be operated.
Press the <b>PROG</b> key. Press the keys  or  until P000 is reached		Enables the access to change parameters content. With the factory default programming [P200 = 1 (Password Active)], P000 must be set to 5 to allow parameters changes
Press the <b>PROG</b> key to enter the programming mode		Enter the programming mode
Use the  and  keys to set the password value		Password value (factory default = 5)
Press the <b>PROG</b> key to save the programmed value and exit the programming mode		Exit the programming mode.
Press the keys  or  until P202 is reached		Type of Control Selection: 0=V/F 60Hz 1=V/F 50Hz 2=V/F Adjustable 3=Sensorless Vector 4=Vector with Encoder 5=VVW

ACTION	LED DISPLAY LCD DISPLAY	DESCRIPTION
Press the  key to enter the programming mode	 	Enter the programming mode
Use the  and  keys to select the type of control	 	If the option V/F 60Hz (value=0) is already programmed, ignore this action
Press the  key to save the selected option and exit the programming mode	 	Exit the programming mode.
Press the  keys or until P002 is reached	 	Motor Speed (rpm)
Press the  key	 	This is a read-only parameter
Press the  Start key	 	Motor accelerates from 0 to 90rpm* (Minimum Speed), in the Forward (CW) direction of rotation <sup>(1)</sup> * for 4 pole motors
Press the  key and hold until 1800 rpm is reached	 	Motor accelerates up to 1800rpm* <sup>(2)</sup> * for 4 pole motors
Press the  FWD / REV key. Obs: The LED's on the keypad show whether the motor is running FWD or REV.	 	Motor decelerates <sup>(3)</sup> down to 0 rpm and then reverses the direction of rotation accelerating back up to 1800rpm

ACTION	LED DISPLAY LCD DISPLAY	DESCRIPTION
Press the  Stop key	 	Motor decelerates down to 0 rpm
Press the  key and hold it	 	Motor accelerates from 0 rpm up to the JOG speed set at P122. <b>Ex.:</b> P122 = 150 rpm CCW direction of rotation
Release the  key	 	Motor decelerates down to 0 rpm



**NOTE!**

The last frequency reference value set via the  and  keys is saved. If you wish to change this value before enabling the inverter, change parameter **P121** (Keypad Reference).

**OBSERVATIONS:**

- (1) If the rotation direction of the motor is not correct, switch off the inverter. Wait 10 minutes to allow a complete discharge of the capacitors and then swap any two wires at the motor output.
- (2) If the acceleration current becomes too high, specially at low frequencies (<15Hz), adjust the Torque Boost at **P136**. Increase/decrease the content of **P136** gradually until you obtain an operation with constant current over the entire frequency range. Refer to P136 in Chapter 6.
- (3) If E01 fault occurs during deceleration, increase the deceleration time at **P101 / P103**.

5.3.2 Type of Control: Sensorless or Vector with Encoder (Operation Via Keypad (HMI))

For the majority of the applications, the **Sensorless Vector** control is recommended. This mode permits an operation over a 100:1 speed range, a speed control accuracy of 0.5 % (Refer to P412 - Chapter 6), high torque and fast dynamic response.

Another advantage of this type of control is a higher immunity to sudden AC input voltage variation and load changes, thus avoiding nuisance tripping due to overcurrent.

The adjustments necessary for a good sensorless control operation are made automatically.

The **Vector Control with Encoder** Feedback offers the same advantages as the Sensorless Control described above, with the following additional benefits:







- ☑ Torque and speed control down to zero speed (rpm);
- ☑ Accuracy of 0.01 % in the speed control







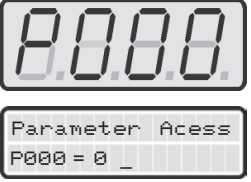

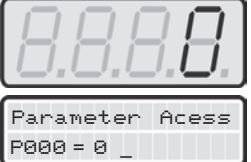









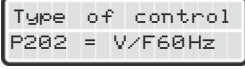

The closed loop vector control with encoder requires the use of the optional board EBA or EBB for encoder connection - Refer to Chapter 8.

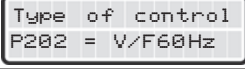



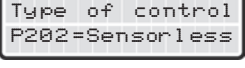



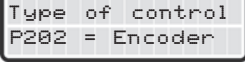

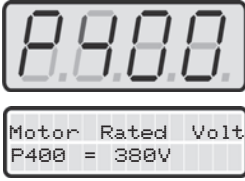



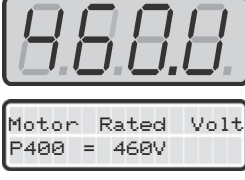

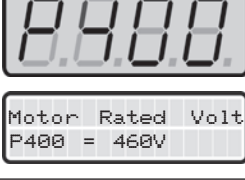
**OPTIMAL BRAKING:**

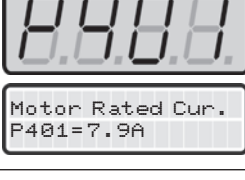

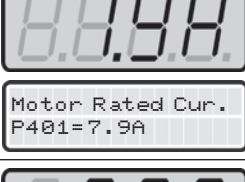

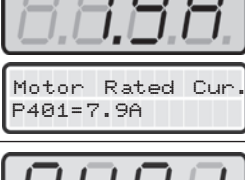

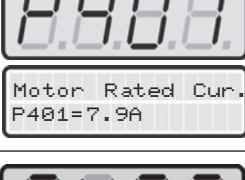

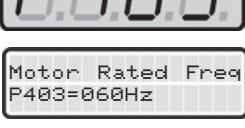



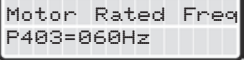



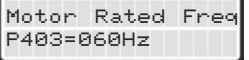

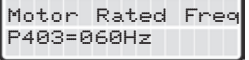

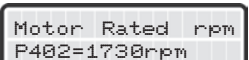

This setting allows controlled motor braking within shortest possible times without using other means, such as DC Link chopper with braking resistor (for more details about this function refer to P151 – Chapter 6). The inverter is supplied with this function set at maximum. This means that the braking is disabled. To enable the braking, set P151 according to Table 6.7.









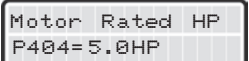







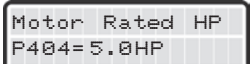

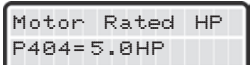

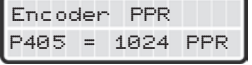
The sequence below is based on the example in Section 5.2.

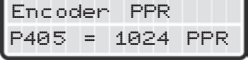





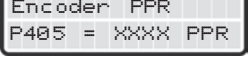

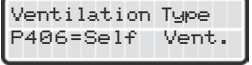



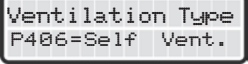

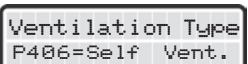

ACTION	LED DISPLAY LCD DISPLAY	DESCRIPTION
Power-up the inverter		Inverter is ready to be enabled
Press the  key. Press the keys  or  until P000 is reached		Enables the access to change parameters content. With the factory default programming [P200 = 1 (Password Active)], P000 must be set to 5 to allow parameters changes
Press the  key to enter the programming mode		Enter the programming mode

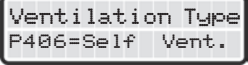

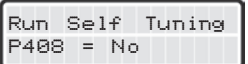

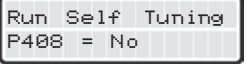



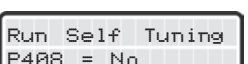







ACTION	LED DISPLAY LCD DISPLAY	DESCRIPTION
Use the  and  keys to set the password value	 	Password value (factory default = 5)
Press the  key to save the programmed value and exit the programming mode	 	Exit the programming mode.
Press the keys  or  until P202 is reached	 	Type of Control Selection: 0=V/F 60Hz 1=V/F 50Hz 2=V/F Adjustable 3=Sensorless Vector 4=Vector with Encoder 5=VVW
Press the  key to enter the programming mode	 	Enter the programming mode
Use the  and  keys to select the type of control <b>(Sensorless)</b>	 	Selected Type of Control: 3 = Sensorless Vector
<b>OR</b>		
Use the  and  keys to select the type of control <b>(with Encoder)</b>	 	Selected Type of Control: 4 = Vector with Encoder

ACTION	LED DISPLAY LCD DISPLAY	DESCRIPTION
Press the  key to save the selected option and start the tuning routine after changing to Vector Control mode		Motor Rated Voltage Range: 0 to 690V
Press the  key and use the  and  keys to set the correct motor rated voltage value		Programmed Motor Rated Voltage: 460V
Press the  key to save the programmed value and exit the programming mode		Exit the programming mode.
Press the  key to go to the next parameter		Motor Rated Current Range: (0.0 to 1.30) x P295 <sup>(1)</sup>
Press the  key to enter the programming mode		Enter the programming mode
Use the  and  keys to set the correct motor rated current value		Programmed Motor Rated Current: 7.9 A
Press the  key to save the programmed value and exit the programming mode		Exit the programming mode.
Press the  key to go to the next parameter		Motor Rated Frequency Range: 0 to 300Hz

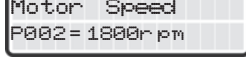
ACTION	LED DISPLAY LCD DISPLAY	DESCRIPTION
Press the  key to enter the programming mode	 	Enter the programming mode
Use the  and  keys to set the correct motor rated frequency value	 	Programmed Motor Rated Frequency: 60 Hz
Press the  key to save the programmed value and exit the programming mode	 	Exit the programming mode.
Press the  key to go to the next parameter	 	Motor Rated rpm Range: 0 to 18000 rpm
Press the  key to enter the programming mode	 	Enter the programming mode
Use the  and  keys to set the correct motor rated rpm value	 	Programmed Motor Rated rpm: 1730 rpm
Press the  key to save the programmed value and exit the programming mode	 	Exit the programming mode.
Press the  key to go to the next parameter	 	Motor Rated HP Range: 1 to 1600.0 HP 1 to 1190.0 kW

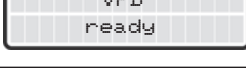

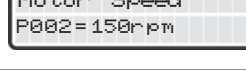
ACTION	LED DISPLAY LCD DISPLAY	DESCRIPTION
Press the  key to enter the programming mode	 	Enter the programming mode
Use the  and  keys to select the motor rated power	 	Selected Motor Rated Power: 7=5.0 HP/3.7 kW
Press the  key to save the selected option and exit the programming mode	 	Exit the programming mode.
Press the  key to go to the next parameter	 	Encoder Pulses per Rotation (PPR) Range: 0 to 9999
Press the  key to enter the programming mode. (Vector with Encoder only)	 	Enter the programming mode
Use the  and  keys to set the correct encoder PPR value. (Vector with Encoder only)	 	Programmed Encoder PPR: XXXX
Press the  key to save the programmed value and exit the programming mode. (Vector with Encoder only)	 	Exit the programming mode.
Press the  key to go to the next parameter	 	Motor Ventilation Type Selection: 0=Self Ventilated 1=Separate Ventilation 2=Optional Flux (only for P202=3) 3=Increased Protection

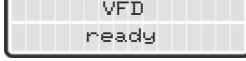
ACTION	LED DISPLAY LCD DISPLAY	DESCRIPTION
Press the  key to enter the programming mode	 	Enter the programming mode
Use the  and  keys to select the motor ventilation type	 	Selected Motor Ventilation Type: 0 = Self Ventilated
Press the  key to save the selected option and exit the programming mode	 	Exit the programming mode.
Press the  key to go to the next parameter Note: Display shows during 3s: P409 to P413=0 Run Self-tuning	 	Self-tuning Mode Selection: 0=No 1=No Rotation 2=Run for $I_m$ 3=Run for $T_M$ (only with Encoder) 4=Estimate $T_M$ (only with Encoder)
Press the  key to enter the programming mode	 	Enter the programming mode
Use the  and  keys to select the desired Self-tuning mode	 	<p><b>Sensorless:</b>                      Only select option 2 (Run for <math>I_m</math>) if no load is coupled to the motor shaft. Otherwise, select option 1 (No Rotation).</p> <p><b>With Encoder:</b>                      In addition to the options above, it is also possible to estimate the <math>T_M</math> (Mechanical Time Constant) value. With the load coupled to the motor shaft, select 3 (Run for <math>T_M</math>). The motor will only run when <math>T_M</math> is estimated. All other parameters are estimated with the motor at standstill. If only <math>T_M</math> estimation is desired, select option 4 (Estimate <math>T_M</math>) (Refer to P408 in Chapter 6)</p>

ACTION	LED DISPLAY LCD DISPLAY	DESCRIPTION
Press the  key to start the self-tuning routine	Messages and values of the estimated parameters are shown	Self-tuning routine in progress
End of the Self-tuning routine. Inverter is back to normal operation	 	Motor Speed (rpm)
Press the  Start key	 	Motor accelerates from 0 to 90 rpm* (Minimum Speed), in the Forward (CW) direction of rotation <sup>(2)</sup> * for 4 pole motors
Press the  key and hold until 1800 rpm is reached	 	Motor accelerates up to 1800 rpm* <sup>(3)</sup> * for 4 pole motors
Press the  FWD / REV key Obs: The LED's on the keypad show whether the motor is running FWD or REV	 	Motor decelerates <sup>(4)</sup> down to 0 rpm and then reverses the direction of rotation accelerating back up to 1800rpm
Press the  Stop key	 	Motor decelerates down to 0 rpm
Press the  key and hold it	 	Motor accelerates from 0 rpm up to the speed set at P122 <b>Ex.:</b> P122 = 150 rpm CCW direction of rotation
Release the  key	 	Motor decelerates down to 0 rpm



**NOTES!**

- (1) P401 maximum value is 1.8xP295 for model 4.2A/500-600V and 1.6xP295 for models 7A and 54A/220-230V; 2.9A and 7A/500-600V; 107A, 147A and 247A/500-690V; 100A, 127A and 340A/660-690V.
- (2) The last speed reference value set via the  and  keys is saved. If you wish to change this value before enabling the inverter, change parameter **P121** (Keypad Reference).
- (3) The self-tuning routine can be cancelled by pressing the  key.
- (4) If E01 fault occurs during deceleration, you must increase deceleration time at **P101 / P103**.

**OBSERVATION:**

If the rotation direction of the motor is not correct, switch off the inverter. Wait 10 minutes to allow a complete discharge of the capacitors and swap any two wires at the motor output. If motor is equipped with an encoder, change the phase of the encoder connections ( exchange channel A and  $\bar{A}$ ).



**ATTENTION!**

In Vector mode (P202=3 or 4), when the command STOP (START/STOP) is enabled - see Figure 6.37, the motor will decelerate up to zero speed, but it maintains the magnetization current (no-load current). This maintains the motor with rated flux and when the next START command is given, it will achieve a quick response.

For self-ventilated motors with no-load current higher than 1/3 of the rated current (generally small motors lower than 10 HP), it is recommended that the motor does not stay in this condition (magnetization current) for a long time, since it may overheat. In these cases, we recommend to deactivate the command “General Enable” (when the motor has stopped), thus decreasing the motor current to zero when stopped.

Another way to disable magnetization current with the motor stopped is to program P211 to 1 (zero speed disable is ON) for both vector modes and, for vector with encoder, still another option is to program P181 to 1 (Magnetization mode). If magnetization current is disabled with the motor stopped, there will be a delay at start while the flux builds up.

5.3.3 Type of Control:  
VW - Keypad  
Operation









The VW (Voltage Vector WEG) control mode follows the same philosophy of the V/F control. The VW control allows a reasonable improvement of the steady-state drive performance: it results in a better speed regulation and in a higher torque capability at low speeds (frequencies lower than 5Hz).



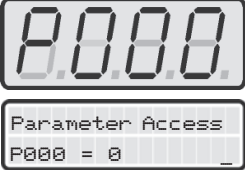
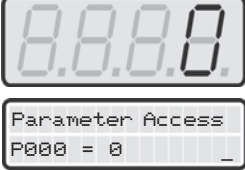

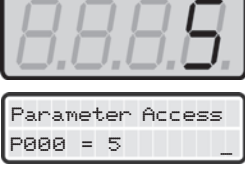
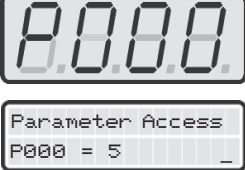



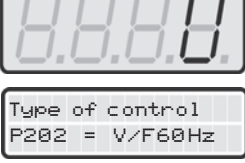









As a result, the frequency (speed) range of the system is increased with respect to the V/F control. Other advantages of this control are the simplicity and ease of setting.









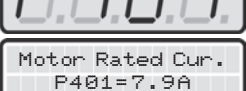







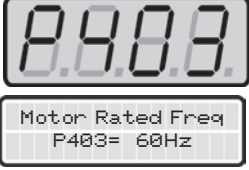

The VW control uses the stator current measurement, the stator resistance (that can be obtained from the self-tuning routine) and the motor nameplate data to automatically estimate the torque value, the output compensation voltage value and, consequently, the slip compensation value, which substitute the function of parameters P137 and P138.













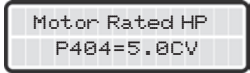

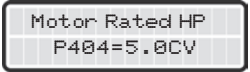



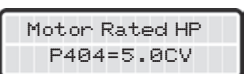

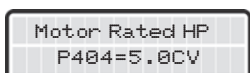

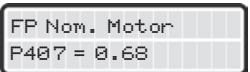
In order to get a good steady-state speed regulation, the slip frequency is calculated from the estimated load torque value (which uses the motor nameplate data).

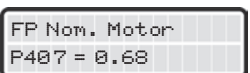











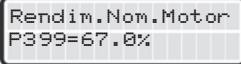

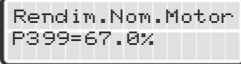



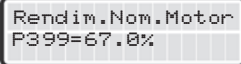

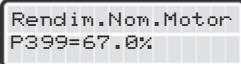
The following sequence is valid for Connection #1 (refer to item 3.2.7). The drive should have been already installed and powered up according to instructions in Chapter 3 and item 5.2.

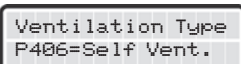

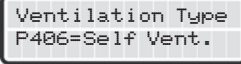



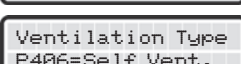

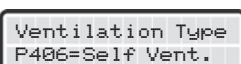

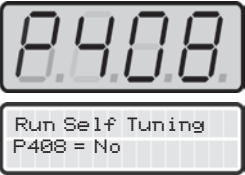
ACTION	LED DISPLAY LCD DISPLAY	DESCRIPTION
Power-up the inverter		Inverter is ready to be operated.
Press the <b>PROG</b> key. Press the keys  or  until P000 is reached.		Enables the access to change parameters content. With the factory default programming [P200=1 (Password Active)], P000 must be set to 5 to allow parameters changes.
Press the <b>PROG</b> key to enter the programming mode		Enter the programming mode
Use the keys  and  to set the password value		Password value (factory default = 5)
Press the key <b>PROG</b> to save the programmed value and exit the programming mode		Exit the programming mode.
Press the keys  or  until P202 is reached.		Type of Control Selection: 0=V/F 60Hz 1=V/F 50Hz 2=V/F Adjustable 3=Sensorless Vector 4=Vector with Encoder 5=VVW
Press the <b>PROG</b> key to enter the programming mode		Enter the programming mode

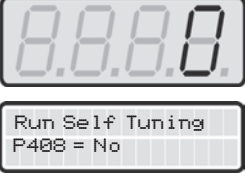

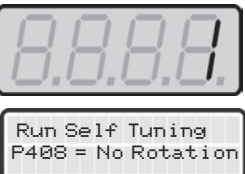

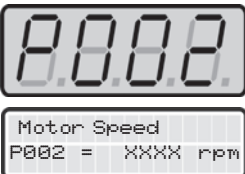

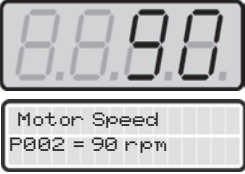
ACTION	LED DISPLAY LCD DISPLAY	DESCRIPTION
Use the  and  keys to select the type of control (VVW).	 Type of control P202 = VVW	Selected Type of Control: 5=VVW
Press the key  to save the selected option and start the tuning routine after changing to VVW Control mode	 Motor Rated Volt P400 = 460V	Motor Rated Voltage Range: 0 to 690V
Press the  key and use the  and  keys to set the correct motor rated voltage value	 Motor Rated Volt P400 = 460V	Programmed Motor Rated Voltage: 460 V
Press the  key to save the programmed value and exit the programming mode	 Motor Rated Volt P400 = 380V	Exit the programming mode.
Press the  key to go to the next parameter	 Motor Rated Cur. P401=7.9A	Motor Rated Current Range: (0.0 to 1.30) x P295 <sup>(1)</sup>
Press the  key to enter the programming mode	 Motor Rated Cur. P401=7.9A	Enter the programming mode
Use the  and  keys to set the correct motor rated current value	 Motor Rated Cur. P401=7.9A	Programmed Motor Rated Current: 7.9 A
Press the  key to save the programmed value and exit the programming mode	 Motor Rated Cur. P401=7.9A	Exit the programming mode.

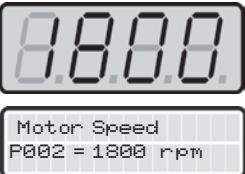
ACTION	LED DISPLAY LCD DISPLAY	DESCRIPTION
Press the  key to go to the next parameter		Motor Rated Frequency Range: 0 to 300Hz
Press the  key to enter the programming mode		Enter the programming mode
Use the  and  keys to set the correct motor rated frequency value		Programmed Motor Rated Frequency: 60 Hz
Press the  key to save the programmed value and exit the programming mode		Exit the programming mode.
Press the  key to go to the next parameter		Motor Rated rpm Range: 0 to 18000 rpm
Press the  key to enter the programming mode		Enter the programming mode
Use the  and  keys to set the correct motor rated rpm value		Programmed Motor Rated rpm: 1730 rpm
Press the  key to save the programmed value and exit the programming mode		Exit the programming mode.

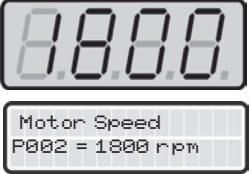
ACTION	LED DISPLAY LCD DISPLAY	DESCRIPTION
Press the  key to go to the next parameter	 	Motor Rated HP Range: 1 to 1600.0 CV 1 to 1190.0 kW
Press the  key to enter the programming mode	 	Enter the programming mode
Use the  and  keys to select the motor rated power	 	Selected Motor Rated Power: 5.0 CV/3.7 kW
Press the  key to save the programmed value and exit the programming mode	 	Exit the programming mode.
Press the  key to go to the next parameter	 	Motor Rated Power Factor 0.50 to 0.99
Press the  key to enter the programming mode	 	Enter the programming mode
Use the  and  keys to select the Motor Rated Power Factor	 	Motor Power Factor: 0.68
Press the  key to save the programmed value and exit the programming mode	 	Exit the programming mode.

ACTION	LED DISPLAY LCD DISPLAY	DESCRIPTION
Press the  key to go to the next parameter	 	Motor Rated Efficiency 50.0 to 99%
Press the  key to enter the programming mode	 	Enter the programming mode
Use the  and  keys to select the Motor Rated Efficiency	 	Motor Rated Efficiency 67.0%
Press the  key to save the programmed value and exit the programming mode	 	Exit the programming mode.
Press the  key to go to the next parameter	 	Motor Ventilation Type Selection: 0=Self Ventilated 1=Separate Ventilation 2=Optimal Flux 3=Increased Protection
Pressionar  para entrar no modo de programação	 	Enter the programming mode
Use the  and  keys to select the motor ventilation type	 	Selected Motor Ventilation Type: 0 = Self Ventilated
Press the  key to save the programmed value and exit the programming mode	 	Exit the programming mode.

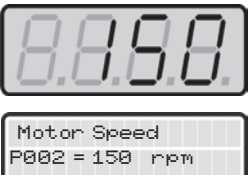
ACTION	LED DISPLAY LCD DISPLAY	DESCRIPTION
<p>Press the  key to go to the next parameter                      Note: Display shows during 3s:                      P409 to P413=0                      Run Self-tuning</p>		<p>Self-tuning Mode Selection:                      0=No                      1=No Rotation</p>
<p>Press the  key to enter the programming mode</p>		<p>Enter the programming mode</p>
<p>Use the  and  keys to select the desired Self-tuning mode                      nota: O display mostrará durante o Auto-ajuste o P409</p>		<p>Only select option 2 (No Rotation)</p>
<p>Press the  key to start the self-tuning routine</p>	<p>Messages and values of the estimated parameters are shown</p>	<p>Self-tuning routine in progress</p>
<p>End of the Self-tuning routine.                      Inverter is back to normal operation</p>		<p>Motor Speed (rpm)</p>
<p>Press the  Start key</p>		<p>Motor accelerates from 0 to 90 rpm* (Minimum Speed), in the Forward (CW) direction of rotation <sup>(2)</sup>                      * for 4 pole motors</p>
<p>Press the  key and hold until 1800 rpm is reached</p>		<p>Motor accelerates up to 1800 rpm* <sup>(3)</sup>                      * for 4 pole motors</p>

ACTION	LED DISPLAY LCD DISPLAY	DESCRIPTION
Press the  FWD / REV key Obs: The LED's on the keypad show whether the motor is running FWD or REV		Motor decelerates <sup>(4)</sup> down to 0 rpm and then reverses the direction of rotation accelerating back ⇒ up to 1800rpm
Press the  Stop key		Motor decelerates down to 0 rpm
Press the  key and hold it		Motor accelerates from 0 rpm up to the speed set at P122 <b>Ex.:</b> P122 = 150 rpm CCW direction of rotation
Release the  key		Motor decelerates down to 0 rpm



**NOTE!**

The drive always stores the last speed reference value set through the keypad. Therefore, if you want to change this value before enabling the drive use the parameter **P121** - Keypad Speed Reference.

**NOTES!**

- (1) If the direction of rotation of the motor is inverted, power the drive down, waits 10 minutes for the complete discharge of capacitors and interchange any two motor output cables.
- (2) In case of having E01 during deceleration, increase the deceleration time through **P101 / P103**.

## DETAILED PARAMETER DESCRIPTION

This Chapter describes in detail all CFW-09 parameters. In order to simplify the explanation, the parameters have been grouped by characteristics and functions:

Read Only Parameters	Variables that can only be viewed on the display but not changed. Examples would be motor speed or motor current.
Regulation Parameters	Programmable values used by the CFW-09 functions. Examples would be Acceleration and Deceleration times.
Configuration Parameters	Set-up parameters that are programmed during inverter start-up and define its basic operation. Examples would be Control Type, Scale Factors and the Input/Output functions.
Motor Parameters	Motor data that is indicated on the motor nameplate. Other motor parameters are automatically measured or calculated during the Self-tuning routine.
Special Function Parameters	It includes parameters related to special functions.







Symbols and definitions used in this chapter:

- (1) Indicates that the parameter can be changed only with the inverter disabled (motor stopped).
- (2) Indicates that the values can change as a function of the motor parameters.
- (3) Indicates that the values can change as a function of P413 (T<sub>m</sub> Constant - obtained during Self-tuning).
- (4) Indicates that the values can change as a function of P409, P411 (obtained during Self-tuning).
- (5) Indicates that the values can change as a function of P412 (T<sub>r</sub> Constant - obtained during Self-tuning).
- (6) Indicates that the values can change as a function of P296.
- (7) Indicates that the values can change as a function of P295.
- (8) Indicates that the values can change as a function of P203.
- (9) Indicates that the values can change as a function of P320.
- (10) (For new drives) User Default = no parameters.
- (11) The inverter will be delivered with settings according to the market, considering the HMI language, V/F 50 Hz or 60 Hz and the required voltage. The reset of the standard factory setting may change the parameters related to the frequency (50Hz/60 Hz). Values within parenthesis mean the factory setting for 50 Hz.
- (12) The maximum value of P156 and P401 is 1.8xP295 for model 4.2A/500-600V and 1.6xP295 for models 7A and 54A/220-230V; 2.9A and 7A/500-600V; 107A, 147A and 247A/500-690V; 100A, 127A and 340A/660-690V.

**Torque Current** = it is the component of the motor total current responsible for torque generation (used in Vector Control).

**Active Current** = it is the component of the motor total current proportional to active electric power absorbed by the motor (used in V/F control).

6.1 ACCESS AND READ ONLY PARAMETERS - P000 to P099

Parameter	Range [Factory Setting] Unit	Description / Notes
<b>P000</b> Parameter Access/ Password Value Setting	0 to 999 [0] -	<ul style="list-style-type: none"> <li><input checked="" type="checkbox"/> This parameter opens the access to change other parameter values. When P200 = 1 (Password Active)] it is necessary to set P000 = 5 to change parameter values.</li> <li><input checked="" type="checkbox"/> By programming P000 with the password that releases access to changing of parameter content plus 1 (Password + 1), you will obtain access only to the parameters with different content that the factory default setting.</li> <li><input checked="" type="checkbox"/> To change the password to any other value (password 1), proceed as follows:               <ol style="list-style-type: none"> <li>1) Set P000=5 (current password) and P200= 0 (password inactive).</li> <li>2) Press the Key .</li> <li>3) Change P200 to 1 (password active).</li> <li>4) Press  again: display shows: P000.</li> <li>5) Press  again: display shows 5 (last password).</li> <li>6) Use the  and  keys to change to the desired password value (password 1).</li> <li>7) Press  : display shows P000. From this moment on, the new password becomes active. Thus, to change parameters content P000 has to be set to the new password. (Password 1).</li> </ol> </li> </ul>
<b>P001</b> Speed Reference	0 to P134 [ - ] 1rpm	<ul style="list-style-type: none"> <li><input checked="" type="checkbox"/> Speed Reference value in rpm (Factory Default). With filter of 0.5s.</li> <li><input checked="" type="checkbox"/> The displayed units can be changed from rpm to other units at parameters P207, P216 and P217. The scale factor can be changed at P208 and P210.</li> <li><input checked="" type="checkbox"/> It does not depend on the speed reference source.</li> <li><input checked="" type="checkbox"/> Through this parameter is possible to change the speed reference (P121) when P221 or P222=0.</li> </ul>
<b>P002</b> Motor Speed	0 to P134 [ - ] 1rpm	<ul style="list-style-type: none"> <li><input checked="" type="checkbox"/> Indicates the actual motor speed in rpm, (factory default). With filter of 0.5s.</li> <li><input checked="" type="checkbox"/> The displayed units can be changed from rpm to other units at parameters P207, P216 and P217. The scale factor can be changed at P208 and P210.</li> <li><input checked="" type="checkbox"/> Through this parameter is possible to change the speed reference (P121) when P221 or P222=0.</li> </ul>
<b>P003</b> Motor Current	0 to 2600 [ - ] 0.1A(<100)-1A(>99.9)	<ul style="list-style-type: none"> <li><input checked="" type="checkbox"/> Indicates inverter output current in ampère (A).</li> </ul>

**CHAPTER 6 - DETAILED PARAMETER DESCRIPTION**

<b>Parameter</b>	<b>Range [Factory Setting] Unit</b>	<b>Description / Notes</b>
<b>P004</b> DC Link Voltage	0 to 1235 [ - ] 1V	<input checked="" type="checkbox"/> Indicates the inverter DC Link voltage in volt (V).
<b>P005</b> Motor Frequency	0 to 1020 [ - ] 0.1Hz	<input checked="" type="checkbox"/> Indicates the inverter output frequency in hertz (Hz).
<b>P006</b> Inverter Status	Rdy, run, sub, Exy [ - ] -	<input checked="" type="checkbox"/> Indicates the inverter status:  <b>rdy-</b> inverter is ready to be started or enabled; <b>run-</b> inverter is enabled; <b>Sub-</b> inverter is disabled and line voltage is too low for operation (undervoltage); <b>Exy-</b> inverter is in a fault condition, 'xy' is the number of the Fault code, example: E06.
<b>P007</b> Output Voltage	0 to 800 [ - ] 1Vac	<input checked="" type="checkbox"/> Indicates the inverter output voltage in volt (V).
<b>P009</b> Motor Torque	0 to 150.0 [ - ] 0.1%	<input checked="" type="checkbox"/> Indicates the torque developed by the motor. It is determined as follows:  $P009 = \frac{Tm \cdot 100}{I_{TM}} \times Y$  Where: Tm = Measured motor torque current I <sub>TM</sub> = Nominal motor torque current given by: N = Speed $I_{TM} = \sqrt{P401^2 - X^2}$ $X = P410 \times \frac{P178}{100}$ $Y = 1 \text{ for } N \leq N_{rated}$ $Y = \frac{N_{rated}}{N} \text{ for } N > N_{rated}$
<b>P010</b> Output Power	0.0 to 1200 [ - ] 0.1kW	<input checked="" type="checkbox"/> Indicates the instantaneous output power in kilowatt (kW).
<b>P012</b> Digital Inputs DI1 to DI8 Status	LCD=1 to 0 LED=0 to 255 [ - ] -	<input checked="" type="checkbox"/> Indicates on the Keypad LCD display the status of the 6 digital inputs of the control board (DI1...DI6), and the 2 digital inputs of the I/O Expansion Board (DI7 and DI8). Number 1 stands for Active (DIx closed) and number 0 stands for Inactive (DIx open), in the following order:  DI1, DI2, ... ,DI7, DI8.  <input checked="" type="checkbox"/> The LED display shows a decimal value related to the 8 Digital Inputs, where the status of each input is considered one bit of a binary number where:

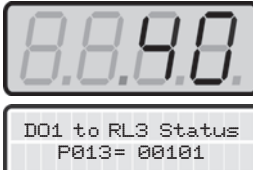
Parameter	Range [Factory Setting] Unit	Description / Notes
		<p>Inactive = 0, Active = 1, and the DI1 status is the most significant bit (MSB).</p> <p>Example:</p> <p>DI1=Active (+24V); DI2=Inactive (0V)</p> <p>DI3=Inactive (0V); DI4=Active (+24V)</p> <p>DI5=Inactive (0V); DI6=Inactive (0V)</p> <p>DI7=Inactive (0V); DI8=Inactive (0V)</p> <p>This is equivalent to the binary sequence:</p> <p style="text-align: center;">10010000</p> <p>Which corresponds to the decimal number 144.</p> <p>The Keypad displays will be as follows:</p> <div style="text-align: center;">  </div>
<p><b>P013</b> Digital and Relay Outputs DO1, DO2 RL1, RL2 and RL3 Status</p>	<p>LCD = 1, 0 LED = 0 to 255 [ - ] -</p>	<p><input checked="" type="checkbox"/> Indicates on the Keypad LCD Display the status of the 2 Digital Outputs of the I/O Expansion Board (DO1, DO2) and the 3 Relay Outputs of the control board. Number 1 stands for Active and number 0 stands for Inactive, in the following order: DO1, DO2, RL1, RL2, RL3.</p> <p><input checked="" type="checkbox"/> The LED display shows a decimal value related to the status of the 5 Digital and Relay Outputs, where the status of each output is considered one bit of a binary number where:</p> <p>Inactive = 0, Active = 1, and the status of DO1 is the most significant bit (MSB). The 3 least significant bits are always '0'.</p> <p>Example:</p> <p>DO1=Inactive; DO2=Inactive</p> <p>RL1=Active; RL2=Inactive; RL3=Active</p> <p>This is equivalent to the binary sequence:</p> <p style="text-align: center;">00101000</p> <p>Which corresponds to the decimal number 40.</p> <p>The Keypad displays will be:</p> <div style="text-align: center;">  </div>

Parameter	Range [Factory Setting] Unit	Description / Notes
<b>P014</b> Last Fault	0 to 70 [ - ] -	<input checked="" type="checkbox"/> Indicates the numbers of the last, second, third and fourth previous Faults. <input checked="" type="checkbox"/> Fault Sequence:
<b>P015</b> Second Previous Fault	0 to 70 [ - ] -	Exy → P014 → P015 → P016 → P017 → P060 → P061 → P062 → P063 → P064 → P065.
<b>P016</b> Third Previous Fault	0 to 70 [ - ] -	<input checked="" type="checkbox"/> Ex: When the display shows 0 (zero), this means E00, 1 (one) means E01 and so on.
<b>P017</b> Fourth Previous Fault	0 to 70 [ - ] -	
<b>P018</b> Analog Input AI1' Value	-100 to +100 [ - ] 0.1%	<input checked="" type="checkbox"/> Indicate the percentage value of the analog inputs AI1 to AI4. The indicated values are obtained after offset action and multiplication by the gain. Refer to parameters P234 to P247.
<b>P019</b> Analog Input AI2' Value	-100 to +100 [ - ] 0.1%	
<b>P020</b> Analog Input AI3' Value	-100 to +100 [ - ] 0.1%	
<b>P021</b> Analog Input AI4' Value	-100 to +100 [ - ] 0.1%	
<b>P022</b> WEG Use	- [ - ] -	
<b>P023</b> Software Version	XXX [ - ] -	<input checked="" type="checkbox"/> Indicates the CFW-09 Software Version.
<b>P024</b> A/D Conversion Value of Analog Input AI4	LCD: -32768 to 32767 LED: 0 to FFFFH [ - ] -	<input checked="" type="checkbox"/> Indicates the A/D conversion result of the analog input A14 located on the I/O Expansion Board. <input checked="" type="checkbox"/> The LCD display indicates the conversion value as a decimal number and the LED display as a hexadecimal number with negative values in supplement of 2.
<b>P025</b> A/D Conversion Value of Iv Current	0 to 1023 [ - ] -	<input checked="" type="checkbox"/> P025 and P026 indicate the A/D conversion result, in module, of the V and W phase currents, respectively.
<b>P026</b> A/D Conversion Value of Iw Current	0 to 1023 [ - ] -	

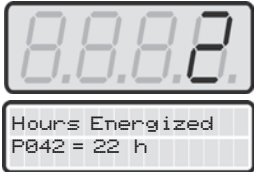
Parameter	Range [Factory Setting] Unit	Description / Notes
<b>P027</b> Analog Output AO1	0 to 100 [ - ] 0.1%	<input checked="" type="checkbox"/> Indicate the percentage value of the analog outputs AO1 to AO4 with respect to the full-scale value. The indicated values are obtained after the multiplication by the gain. Refer to the description of parameters P251 to P258.
<b>P028</b> Analog Output AO2	0 to 100 [ - ] 0.1%	
<b>P029</b> Analog Output AO3	-100 to +100 [ - ] 0.1%	
<b>P030</b> Analog Output AO4	-100 to +100 [ - ] 0.1%	
<b>P040</b> PID Process variable	0 to P528 [ - ] 1	<input checked="" type="checkbox"/> It indicates the process variable in % (factory setting), used as the PID Feedback. <input checked="" type="checkbox"/> The indication unit can be changed through P530, P531 and P532. The scale can be changed through P528 and P529. <input checked="" type="checkbox"/> See detailed description in Item 6.5 - Special Function Parameters. <input checked="" type="checkbox"/> This parameter also allows to modify the PID set point (P252) when P221=0 or P222=0.
<b>P042</b> Powered Time	LCD: 0 to 65530h LED: 0 to 6553h (x10) [ - ] 1	<input checked="" type="checkbox"/> Indicates the total number of hours that the inverter was powered. <input checked="" type="checkbox"/> The LED Display shows the total number of hours that the inverter was energized divided by 10. <input checked="" type="checkbox"/> This value remains stored even when the inverter is turned OFF. Example: Indication of 22 hours powered.
		
<b>P043</b> Enabled Time	0 to 6553h [ - ] 0.1 (<999.9) 1 > 1000	<input checked="" type="checkbox"/> Indicates the total number of hours that the inverter has <b>run</b> . <input checked="" type="checkbox"/> Indicates up to 6553 hours, rolls over to 0000. <input checked="" type="checkbox"/> If P204 is set to 3, the P043 is reset to zero. <input checked="" type="checkbox"/> This value remains stored even when inverter is turned OFF.

Parameter	Range [Factory Setting] Unit	Description / Notes
<b>P044</b> kWh Counter	0 to 65535kWh [ - ] 1	<ul style="list-style-type: none"> <li><input checked="" type="checkbox"/> Indicates the energy consumed by the motor.</li> <li><input checked="" type="checkbox"/> Indicates up to 65535 kWh, then it return to zero.</li> <li><input checked="" type="checkbox"/> If P204 is set to 4, the P044 is reset to zero.</li> <li><input checked="" type="checkbox"/> This value remains stored even when inverter is turned OFF.</li> </ul>
<b>P060</b> Fifth Error	0 to 70 [ - ] -	<input checked="" type="checkbox"/> Indicates the numbers of the fifth, sixth, seventh, eighth ninth and tenth occurred error, respectively
<b>P061</b> Sixth Error	0 to 70 [ - ] -	<ul style="list-style-type: none"> <li><input checked="" type="checkbox"/> Record Systematic: Exy → P014 → P015 → P016 → P017 → P060 → P061 → P062 → P063 → P064 → P065</li> </ul>
<b>P062</b> Seventh Error	0 to 70 [ - ] -	<input checked="" type="checkbox"/> Ex: When the display show 0 (zero), this means E00, 1 (one) means E01 and so on.
<b>P063</b> Eighth Error	0 to 70 [ - ] -	
<b>P064</b> Ninth Error	0 to 70 [ - ] -	
<b>P065</b> Tenth Error	0 to 70 [ - ] -	
<b>P070</b> Motor Speed and Motor Current	0 to P134 [ - ] 1 rpm  0 to 2600 [ - ] 0.1A(<100) 1A(>99.9)	<ul style="list-style-type: none"> <li><input checked="" type="checkbox"/> Indicates simultaneously the motor speed value (rpm) and the motor current value (A).</li> <li><input checked="" type="checkbox"/> It is possible to use this parameter to change the speed reference (P121) when P221 or P222=0.</li> </ul> <p> <b>NOTE!</b> The LED display shows the speed.</p>
<b>P071</b> Command Word	LCD: 0 a 65535 LED: 0 a FFFFh	<ul style="list-style-type: none"> <li><input checked="" type="checkbox"/> Shows the command word value set through the network</li> <li><input checked="" type="checkbox"/> The LCD display of the keypad shows the value in a decimal representation, while the LED display shows the value in a hexadecimal representation.</li> </ul>
<b>P072</b> Fieldbus Speed Reference	LCD: 0 a 65535 LED: 0 a FFFFh	<ul style="list-style-type: none"> <li><input checked="" type="checkbox"/> Shows the speed reference value set through the Fieldbus network</li> <li><input checked="" type="checkbox"/> The LCD display of the keypad shows the value in a decimal representation, while the LED display shows the value in a hexadecimal representation.</li> </ul>

6.2 REGULATION PARAMETERS - P100 to P199

Parameter	Range [Factory Setting] Unit	Description / Notes
<b>P100</b> Acceleration Time	0.0 to 999 [ 20 ] 0.1s (< 99.9) - 1s (>99.9)	<input checked="" type="checkbox"/> Setting the value to 0.0s results in no Acceleration ramp. <input checked="" type="checkbox"/> Defines the time to accelerate (P100) linearly from zero up to the maximum speed (P134) or to decelerate (P101) linearly from the maximum speed down to 0 rpm.
<b>P101</b> Deceleration Time	0.0 to 999 [ 20 ] 0.1s (< 99.9) - 1s (>99.9)	<input checked="" type="checkbox"/> The selection of the Acceleration / Deceleration Time Ramp 2 (P102 or P103) can be made by reprogramming one of the digital inputs DI3 to DI8. Refer to P265 to P270 in Ramp 2.
<b>P102</b> Acceleration Time 2	0.0 to 999 [ 20 ] 0.1s (< 99.9) - 1s (>99.9)	
<b>P103</b> Deceleration Time 2	0.0 to 999 [ 20 ] 0.1s (< 99.9) - 1s (>99.9)	

<b>P104</b> S Ramp	0 to 2 [ 0 ] -
-----------------------	----------------------

P104	S Ramp
0	Inactive
1	50%
2	100%

Table 6.0 - Choosing S or Linear Ramp

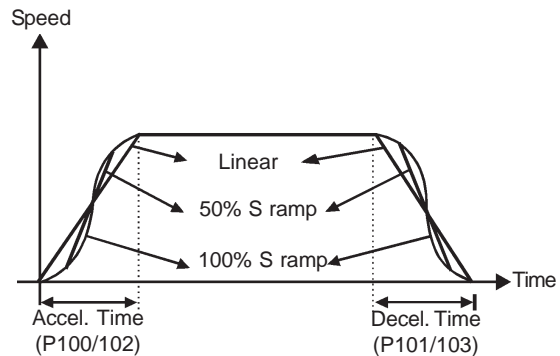



Figure 6.1 - S or Linear Ramp

The ramp S reduces the mechanical stress during the acceleration and deceleration of the load.

<b>P120</b> Speed Reference Backup	0 to 1 [ 1 ] -	<input checked="" type="checkbox"/> Defines if the Frequency Reference Backup function is disabled (0) or enabled (1). <input checked="" type="checkbox"/> If P120 = Off, the inverter does not save the current reference value, when the inverter is enabled again, it will restart from the minimum frequency setting (P133). <input checked="" type="checkbox"/> This back-up function is applicable to the keypad (HMI), P.E, Serial, Fieldbus and PID Setpoint (P525) references.
---------------------------------------	----------------------	---

Parameter	Range [Factory Setting] Unit	Description / Notes						
		<table border="1"> <thead> <tr> <th>P120</th> <th>Backup</th> </tr> </thead> <tbody> <tr> <td>0</td> <td>Off</td> </tr> <tr> <td>1</td> <td>On</td> </tr> </tbody> </table>	P120	Backup	0	Off	1	On
P120	Backup							
0	Off							
1	On							

Table 6.1 - Speed Reference Backup

<b>P121</b> Keypad Speed Reference	P133 to P134 [ 90 ] 1rpm	<input checked="" type="checkbox"/> To activate the  and  active: P221=0 or P222=0. <input checked="" type="checkbox"/> With P120 = 1 (On) the content of P121 is maintained (backup) even when the inverter is disabled or turned off.
---------------------------------------	--------------------------------	--

<b>P122</b> <sup>(2)(11)</sup> JOG or JOG+ Speed Reference	0 to P134 [ 150 (125) ] <sup>(11)</sup> 1rpm	<input checked="" type="checkbox"/> The JOG command source is defined at P225 (Local Mode) or P228 (Remote Mode). <input checked="" type="checkbox"/> If the JOG command is selected for DI3 to DI8, one of the Digital Inputs must be programmed as follows:
---	--	--

<b>P123</b> <sup>(2)(11)</sup> JOG - Speed Reference	0 to P134 [ 150 (125) ] <sup>(11)</sup> 1rpm	<table border="1"> <thead> <tr> <th>Digital Input</th> <th>Parameters</th> </tr> </thead> <tbody> <tr> <td>DI3</td> <td>P265 = 3 (JOG)</td> </tr> <tr> <td>DI4</td> <td>P266 = 3 (JOG)</td> </tr> <tr> <td>DI5</td> <td>P267 = 3 (JOG)</td> </tr> <tr> <td>DI6</td> <td>P268 = 3 (JOG)</td> </tr> <tr> <td>DI7</td> <td>P269 = 3 (JOG)</td> </tr> <tr> <td>DI8</td> <td>P270 = 3 (JOG)</td> </tr> </tbody> </table>	Digital Input	Parameters	DI3	P265 = 3 (JOG)	DI4	P266 = 3 (JOG)	DI5	P267 = 3 (JOG)	DI6	P268 = 3 (JOG)	DI7	P269 = 3 (JOG)	DI8	P270 = 3 (JOG)
Digital Input	Parameters															
DI3	P265 = 3 (JOG)															
DI4	P266 = 3 (JOG)															
DI5	P267 = 3 (JOG)															
DI6	P268 = 3 (JOG)															
DI7	P269 = 3 (JOG)															
DI8	P270 = 3 (JOG)															

Table 6.2 - JOG Command selected by digital input

- During the JOG command, the motor accelerates to the value defined at P122, following the acceleration ramp setting.
- The direction of rotation is defined by the Forward/Reverse function (P223 or P226).
- JOG is effective only with the motor at standstill.
- The JOG+ and JOG- commands are always via Digital Inputs.
- One DIx must be programmed for JOG+ and another for JOG- as follows:

Digital Inputs	Parameters	
	JOG+	JOG-
DI3	P265 = 10	P265 = 11
DI4	P266 = 10	P266 = 11
DI5	P267 = 10	P267 = 11
DI6	P268 = 10	P268 = 11
DI7	P269 = 10	P269 = 11
DI8	P270 = 10	P270 = 11

Table 6.3 - JOG+ and JOG- command selection

Parameter	Range [Factory Setting] Unit	Description / Notes
		<ul style="list-style-type: none"> <li><input checked="" type="checkbox"/> During the JOG + or JOG- commands the values of P122 or P123 are respectively added to, or subtracted from the speed reference to generate the total reference. Refer to Figure 6.26.</li> </ul>
<b>P124</b> <sup>(2)(11)</sup> Multispeed Ref. 1	P133 to P134 [ 90 (75) ] <sup>(11)</sup> 1rpm	<ul style="list-style-type: none"> <li><input checked="" type="checkbox"/> These parameters (P124 to P131) are shown only when P221 = 8 and/or P222 = 8 (Multispeed).</li> </ul>
<b>P125</b> <sup>(2)(11)</sup> Multispeed Ref. 2	P133 to P134 [ 300 (250) ] <sup>(11)</sup> 1rpm	<ul style="list-style-type: none"> <li><input checked="" type="checkbox"/> Multispeed is used when the selection of a number (up to 8) of pre-programmed speeds is desired:</li> <li><input checked="" type="checkbox"/> If you want to use only 2 or 4 speeds, any input combination of DI4, DI5 and DI6 can be used. The input(s) programmed for other function(s) must be considered as 0V in the table 6.4.</li> </ul>
<b>P126</b> <sup>(2)(11)</sup> Multispeed Ref. 3	P133 to P134 [ 600 (500) ] <sup>(11)</sup> 1rpm	<ul style="list-style-type: none"> <li><input checked="" type="checkbox"/> It allows control of the speed by relating the values programmed in parameters P124 to P131 to a logical combination of the Digital Inputs.</li> </ul>
<b>P127</b> <sup>(2)(11)</sup> Multispeed Ref. 4	P133 to P134 [ 900 (750) ] <sup>(11)</sup> 1rpm	<ul style="list-style-type: none"> <li><input checked="" type="checkbox"/> The advantages of this function are stability of the fixed references and electrical noise immunity (isolated digital inputs DIx).</li> </ul>
<b>P128</b> <sup>(2)(11)</sup> Multispeed Ref. 5	P133 to P134 [ 1200 (1000) ] <sup>(11)</sup> 1rpm	<ul style="list-style-type: none"> <li><input checked="" type="checkbox"/> Multispeed function is active when <b>P221</b> (Local Mode) or <b>P222</b> (Remote Mode) is set to 8 (Multispeed).</li> </ul>
<b>P129</b> <sup>(2)(11)</sup> Multispeed Ref. 6	P133 to P134 [ 1500 (1250) ] <sup>(11)</sup> 1rpm	
<b>P130</b> <sup>(2)(11)</sup> Multispeed Ref. 7	P133 to P134 [ 1800 (1500) ] <sup>(11)</sup> 1rpm	
<b>P131</b> <sup>(2)(11)</sup> Multispeed Ref. 8	P133 to P134 [ 1650 (1375) ] <sup>(11)</sup> 1rpm	

Digital Input		Programming	
DI4		P266 = 7	
DI5		P267 = 7	
DI6		P268 = 7	

8 speeds			
4 speeds			
2 speeds			
DI6	DI5	DI4	Speed Ref.
0V	0V	0V	P124
0V	0V	24V	P125
0V	24V	0V	P126
0V	24V	24V	P127
24V	0V	0V	P128
24V	0V	24V	P129
24V	24V	0V	P130
24V	24V	24V	P131

Table 6.4 - Multispeed References

Parameter	Range [Factory Setting] Unit	Description / Notes
-----------	------------------------------------	---------------------

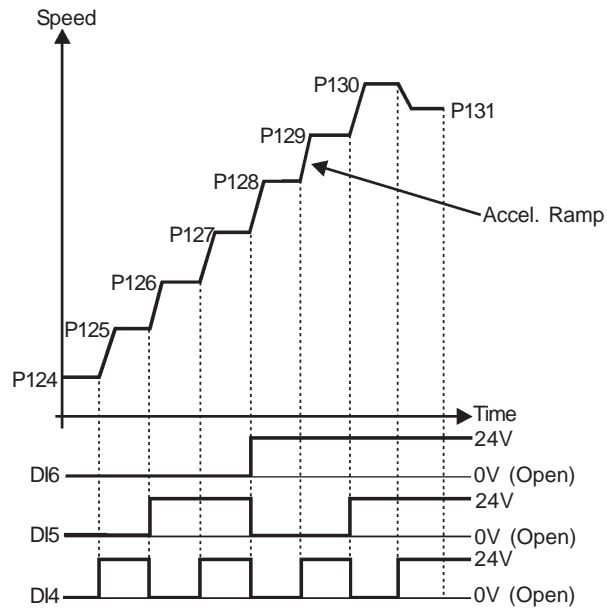
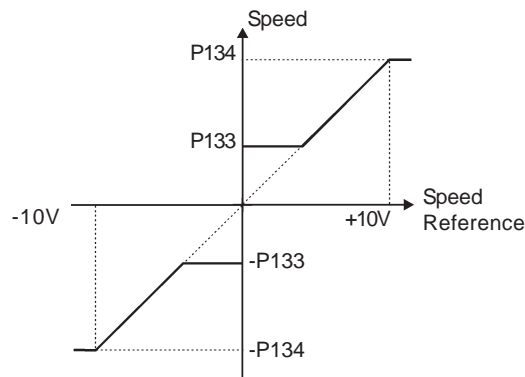

Figure 6.2 - Multispeed

<b>P132</b> <sup>(1)</sup> Maximum Overspeed Level	0 to 100 [ 10 ] 1%	<ul style="list-style-type: none"> <li>☑ When the effective overspeed exceeds the value of P134+P132 longer than 20ms, the CFW-09 will disable the PWM pulses by E17.</li> <li>☑ The P132 setting is a value in percent of P134.</li> <li>☑ When programmed P132 = 100%, this function remains disabled.</li> </ul>
--	--------------------------	---

<b>P133</b> <sup>(2)</sup> Minimum Speed Ref.	0.0 to (P134-1) [ 90 (75) ] <sup>(11)</sup> 1rpm	<ul style="list-style-type: none"> <li>☑ Defines the maximum and minimum motor operation speed reference. Are valid for any type of speed reference signal.</li> <li>☑ For more details about the actuation of P133 refer to P233 (Analog Inputs Dead Zone).</li> </ul>
<b>P134</b> <sup>(2)</sup> Maximum Speed Ref.	(P133+1) to (3.4xP402) [ 1800 (1500) ] <sup>(11)</sup> 1rpm	

a)



Parameter	Range [Factory Setting] Unit	Description / Notes
		<p>b)</p> <p style="text-align: center;"><i>Figure 6.3 a) b) - Speed limits considering the "Dead Zone" active (P233=1)</i></p>
<p><b>P135</b> <sup>(2)</sup> Speed transition to I/F Control</p> <p> This parameter is shown on the display(s) only when P202 = 3 (Sensorless Vector Control)</p>	<p>0 to 90 [ 18 ] 1rpm</p>	<ul style="list-style-type: none"> <li><input checked="" type="checkbox"/> The speed at which the transition from Sensorless Vector Control to I/F (Scalar Control with Imposed Current) occurs. The minimum speed recommended for Sensorless Vector control is 18 rpm for 60 Hz motors and 15 rpm for 50 Hz motors, with 4 poles.</li> <li><input checked="" type="checkbox"/> For <math>P135 \leq 3</math> the CFW-09 will always operate in Sensorless Vector mode when <math>P202 = 3</math>, (There is no transition to the I/F mode).</li> <li><input checked="" type="checkbox"/> The current level to be applied on the motor in the I/F mode is set at P136.</li> <li><input checked="" type="checkbox"/> Scalar control with imposed current means only current control working with current reference level adjusted by P136. There is no speed control, just open loop frequency control.</li> </ul>
<p><b>P136</b> Manual Torque Boost For V/F Control (P202 = 0, 1 or 2)</p>	<p>0 to 9 [ 1 ] 1</p>	<ul style="list-style-type: none"> <li><input checked="" type="checkbox"/> Compensates for the voltage drop on the motor stator resistance at low frequencies and increases the inverter output voltage in order to maintain a constant torque in V/F operation.</li> <li><input checked="" type="checkbox"/> Always set P136 to the lowest value that permits the motor to start satisfactorily. If the value is higher than required, an inverter overcurrent (E00 or E05) may occur due to high motor currents at low frequencies.</li> </ul>

Parameter	Range [Factory Setting] Unit	Description / Notes
-----------	------------------------------------	---------------------

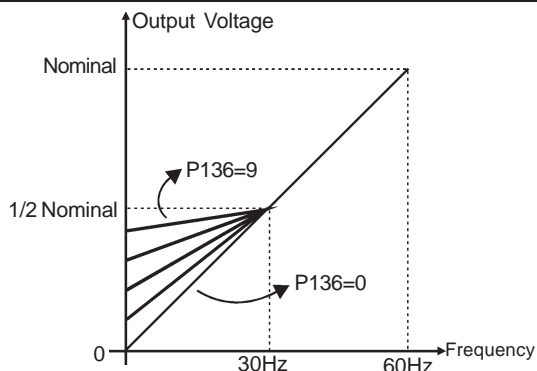

Figure 6.4 - P202=0- V/F 60Hz Curve

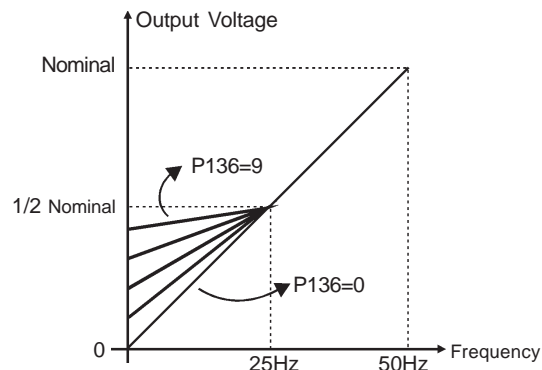

Figure 6.5 - P202 = 1 - V/F 50Hz Curve

<p><b>P136</b> Current Reference for I/F Mode <b>For Sensorless Vector Control (P202=3)</b></p>	<p>0 to 9 [ 1 ] 1</p>
---	-------------------------------

Sets the current to be applied to the motor when in I/F mode. I/F mode occurs when the motor speed is lower than the value defined by parameter P135.

P136	Current in I/F mode % of P410 (Imr)
0	100%
1	111%
2	122%
3	133%
4	144%
5	155%
6	166%
7	177%
8	188%
9	200%

Table 6.5 - Current Reference for I/F Mode

Parameter	Range [Factory Setting] Unit	Description / Notes
<b>P137</b> Automatic Torque Boost	0.00 to 1.00 [ 0.00 ] 0.01	<ul style="list-style-type: none"> <li><input checked="" type="checkbox"/> The automatic Torque Boost compensates for the voltage drop in the stator resistance as a function of the motor active current.</li> <li><input checked="" type="checkbox"/> The criteria for setting P137 are the same as for the parameter P136.</li> </ul>

 This parameter is shown on the display(s) only when P202 = 0, 1 or 2 (V/F Control)

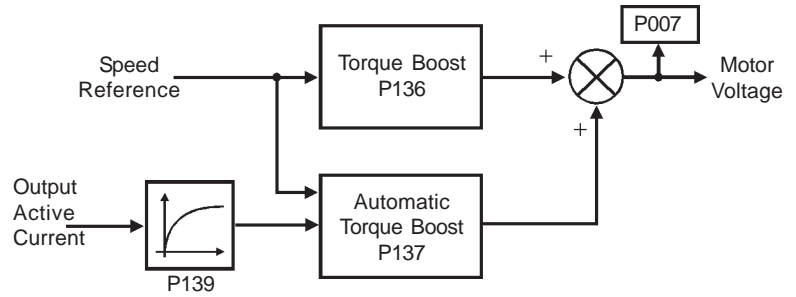

Figure 6.6 - Block Diagram P137

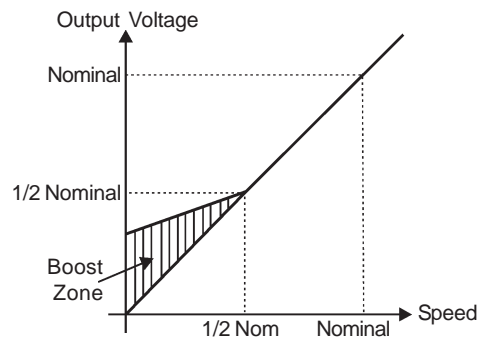



Figure 6.7 - V/F curve with automatic torque boost

<b>P138</b> Slip Compensation	-10.0 to +10.0% [ 0.0 ] 0.1%	<ul style="list-style-type: none"> <li><input checked="" type="checkbox"/> P138 (for values between 0.0% and +10.0%) is used in the Motor Slip Compensation output frequency function, which compensates for the speed drop as the load increases.</li> <li><input checked="" type="checkbox"/> P138 allows the user to set the VSD for more accurate slip compensation. Once set up P138 will compensate for speed variations due to load by automatically adjusting both voltage and frequency.</li> </ul>
----------------------------------	------------------------------------	--

 This parameter is shown on the display(s) only when P202 = 0, 1 or 2 (V/F Control)

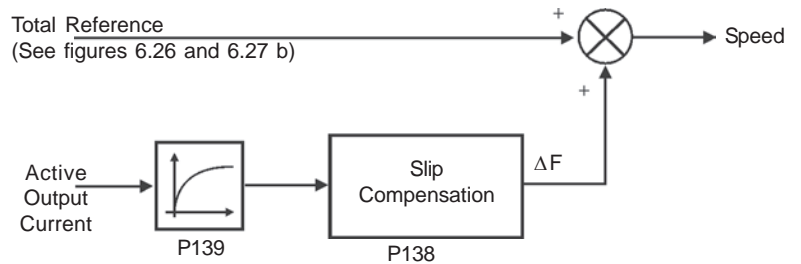

Figure 6.8 - Block Diagram P138

Parameter	Range [Factory Setting] Unit	Description / Notes
		<div data-bbox="784 342 1304 695" data-label="Figure"> </div> <p data-bbox="789 722 1252 747"><b>Figure 6.9 - V/F Curve with Slip Compensation</b></p> <ul style="list-style-type: none"> <li data-bbox="610 774 919 800">☑ <b>To set Parameter 138:</b> <ul style="list-style-type: none"> <li data-bbox="610 821 1312 884">⇒Run the motor without load up to approximately half of the application top speed;</li> <li data-bbox="610 900 1179 926">⇒Measure the actual motor or equipment speed;</li> <li data-bbox="610 945 769 970">⇒Apply load;</li> <li data-bbox="610 989 1284 1014">⇒Increase <b>P138</b> until the speed reaches its no-load value.</li> </ul> </li> <li data-bbox="610 1045 1443 1136">☑ Values of P138 &lt; 0.0 are used in special applications, where the reduction of the output speed is desired as function of the motor current increase. Ex.: load sharing between two motor/drive sets.</li> </ul>
<p data-bbox="77 1171 337 1297"><b>P139</b> Output Current Filter [only for P202 = 0, 1 or 2 (for V/F control)]</p> <p data-bbox="77 1308 337 1493">☞ <b>This parameter is shown on the display(s) only when P202 = 0, 1, 2 (V/F Control) or 5 (VVW)</b></p>	<p data-bbox="386 1171 542 1266">0.00 to 16.00 [ 1.00 ] 0,01s</p>	<ul style="list-style-type: none"> <li data-bbox="610 1171 1230 1197">☑ Adjusts the time constant of the active current filter.</li> <li data-bbox="610 1220 1443 1283">☑ It is used in the Automatic Torque Boost and Slip Compensation functions. See figures 6.7 and 6.8.</li> <li data-bbox="610 1304 1443 1367">☑ Adjusts the response time of the slip compensation and automatic torque boost. Refer to Figures 6.6 and 6.8.</li> </ul>
<p data-bbox="77 1545 337 1608"><b>P140</b> Dwell Time at Start</p>	<p data-bbox="418 1545 509 1640">0 to 10 [ 0 ] 0.1s</p>	<ul style="list-style-type: none"> <li data-bbox="610 1545 1443 1608">☑ Assist during high torque starts by allowing the motor to establish the flux before starting to accelerate the load.</li> </ul>
<p data-bbox="77 1671 337 1734"><b>P141</b> Dwell Speed at Start</p> <p data-bbox="77 1776 337 1961">☞ <b>This parameter is shown on the display(s) only when P202 = 0, 1, 2 (V/F Control) or 5 (VVW)</b></p>	<p data-bbox="418 1671 509 1766">0 to 300 [ 90 ] 1rpm</p>	

Parameter	Range [Factory Setting] Unit	Description / Notes
		<p style="text-align: center;"><b>Figure 6.10 - Curve for high torque starts</b></p>
<b>P142</b> <sup>(1)</sup> Maximum Output Voltage	0 to 100 [ 100 ] 0.1%	<input checked="" type="checkbox"/> These parameters allow changing the standard V/F curves defined at P202. Special V/F profiles may be necessary when motors with non-standard voltages/frequencies are used.
<b>P143</b> <sup>(1)</sup> Intermediate Output Voltage	0 to 100 [ 50 ] 0.1%	<input checked="" type="checkbox"/> This function allows changing the predefined standard curves, which represents the relationship between the output voltage and the output frequency of the drive, and consequently, the motor magnetization flux. This feature may be useful with special applications that require rated voltage values or rated frequency values different from the standard ones.
<b>P144</b> <sup>(1)</sup> Output Voltage at 3 Hz	0 to 100 [ 8 ] 0.1%	<input checked="" type="checkbox"/> Function activated by setting P202 = 2 (V/F Adjustable). <input checked="" type="checkbox"/> The factory default value of P144 (8.0%) is defined for standard 60 Hz motors. If the rated motor frequency (set at P403) is different from 60 Hz, the factory default value of P144 can become unsuitable and may cause troubles during motor start. A good approach for the setting of P144 is given by
<b>P145</b> <sup>(1)</sup> Field Weakening Speed	P133(>90) to P134 [ 1800 ] 1rpm	$P144 = \frac{3}{P403} \times P142$
<b>P146</b> <sup>(1)</sup> Intermediate Speed	90 to P145 [ 900 ] 1rpm	If an increase of the starting torque is required, increase the value of P144 gradually.
<b>These parameter are shown on the display(s) only when P202 = 0, 1 or 2 (V/F Control)</b>		<input checked="" type="checkbox"/> Procedures for the parameter setting of the function “Adjustable V/F”: 1.Disable Inverter; 2.Check inverter data (P295 to P297); 3.Set motor data (P400 to P406); 4.Set display data in P001 and P002 (P208, P210, P207, P216 and P217); 5.Set speed limits (P133 and P134); 6.Set parameters of the function “Adjustable V/F” (P142 to P146); 7.Enable function “Adjustable V/F” (P202=2).

Parameter	Range [Factory Setting] Unit	Description / Notes
-----------	------------------------------------	---------------------

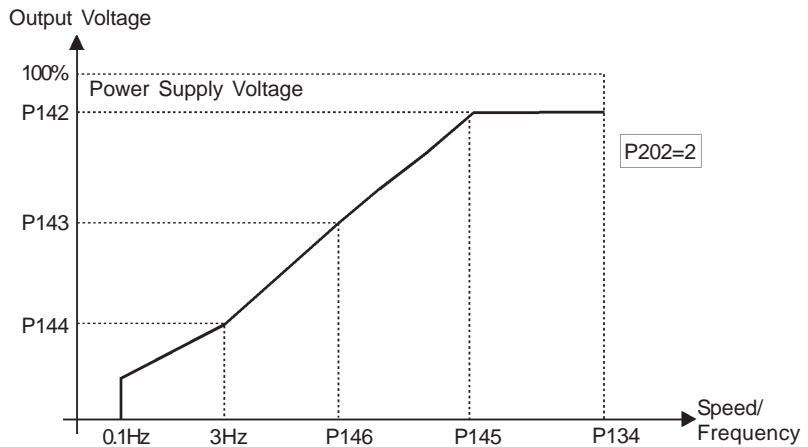

Figure 6.11 - Adjustable V/F Curve V/F

**P150** <sup>(1)</sup>  
DC Link Voltage  
Regulation Mode

0 to 2  
[ 1 ]  
-

This parameter is shown on the display(s) only when P202 = 3 or 4 (Vector Control)

P150	Action
0=With losses (Optimal Braking)	Optimal braking is active as described in P151 for vector control. This gives the shortest possible deceleration time without using dynamic braking or regeneration.
1=Without losses	Automatic deceleration ramp control. Optimal braking is not active. The deceleration ramp is automatically adjusted to keep the DC link voltage below the level set in P151. This avoids E01 DC link overvoltage tripping. Can also be used with eccentric loads.
2=Enable/Disable via Dlx	<input checked="" type="checkbox"/> <b>Dlx=24V:</b> The Braking acts as described for P150=1; <input checked="" type="checkbox"/> <b>Dlx=0V:</b> The Optmal Braking becomes inactive. The DC link voltage will be controlled by parameter P153 (Dynamic Braking).

Table 6.6 - DC Link Voltage Regulation Mode

**P151** <sup>(6)</sup>  
DC Link Voltage  
Regulation Level  
For V/F Control  
(P202=0,1, 2 or 5)

339 to 400 (P296=0)  
[ 400 ]  
1V  
585 to 800 (P296=1)  
[ 800 ]  
1V  
616 to 800 (P296=2)  
[ 800 ]  
1V  
678 to 800 (P296=3)  
[ 800 ]  
1V

P151 sets the DC Link Voltage Regulation Level to prevent E01-overvoltage. This Parameter jointly with the Parameter P152 allows two operation modes for the DC Link Voltage Regulation. Please find below a description of the two operation modes.

**DC Link Voltage Regulation type when P152=0.00 and P151 is different from the maximum value:** ramp Holding – When the DC Link Voltage reaches the Regulation Level during the deceleration, the deceleration ramp time is increased and the speed is maintained at a constant value till the DC Link Voltage leaves the actuation. See Figure 6.12.

This DC Link Voltage Regulation (ramp holding) tries to avoid the inverter disabling through fault relating to DC Link Overvoltage(E01), when the deceleration of loads with high inertia is carried out, or deceleration with short times are performed.

Parameter	Range [Factory Setting] Unit	Description / Notes
	739 to 800 (P296=4) [ 800 ] 1V	
	809 to 1000 (P296=5) [ 1000 ] 1V	
	885 to 1000 (P296=6) [ 1000 ] 1V	
	924 to 1000 (P296=7) [ 1000 ] 1V	
	1063 to 1200 (P296=8) [ 1200 ] 1V	

Figure 6.12 - Deceleration with Ramp Holding

- With this function you can achieve a optimized deceleration time (minimum) for the driven load.
- This function is useful in application where loads with medium moment of inertia are driven, that require short deceleration ramps.
- If even so the inverter is disabled during the acceleration due to overvoltage (E01), reduce the value of P151 gradually, or increase the deceleration ramp time (P101 and/or P103).
- In case the supply line is permanently under overvoltage ( $U_d > P151$ ), the inverter cannot decelerate. In this case reduce the line voltage or increment P151.
- If even after these settings the motor cannot decelerate within the required deceleration time, use the dynamic braking. (For more details about the dynamic braking, see 8.10).

**Type of DC Link Voltage Regulation when P152>0.00 and P151 are set different that than the maximum value:** When the DC Link Voltage reaches the regulation level during the deceleration, the deceleration ramp time is increased and the motor is also accelerated until the DC link voltage leaves the defined over-voltage level. There after deceleration is continued. See Figure 6.13.

Inverter	220/	380V	400/	440/	480V	500/	575V	600V	660/
$V_{rated}$	230V		415V	460V		525V			690V
P296	0	1	2	3	4	5	6	7	8
P151	375V	618V	675V	748V	780V	893V	972V	972V	1174V

Table 6.7 - Recommended values for DC link voltage regulation level

Parameter	Range [Factory Setting] Unit	Description / Notes
-----------	------------------------------------	---------------------

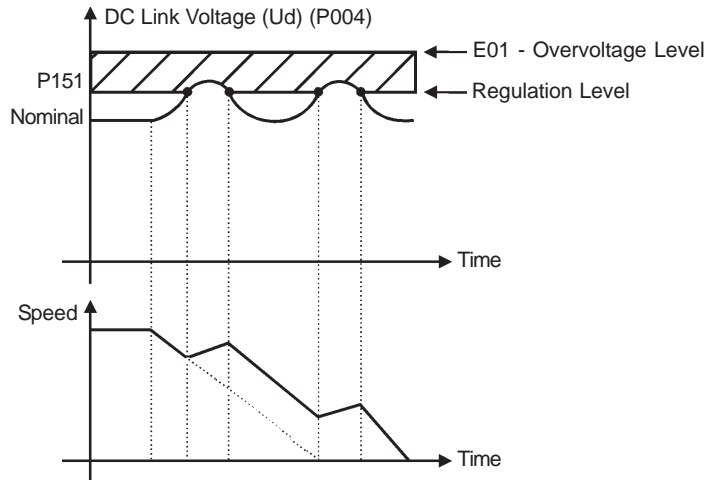

Figure 6.13 - Deceleration curve with DC Link voltage limitation (regulation)



**NOTES!**

- ☑ The factory setting is at maximum (link regulation is deactivated). To activate this regulation, we recommend to set P151 according Table 6.7.
- ☑ If even after this setting the inverter is still disabled due to overvoltage (E01) during the load acceleration, increase the value of the Parameter P152 gradually, or increase the deceleration ramp time (P101 and/or P103). The inverter will not decelerate, if the supply line is permanently under overvoltage  $U_d > P151$ . In this case reduce the line voltage or increment P151.

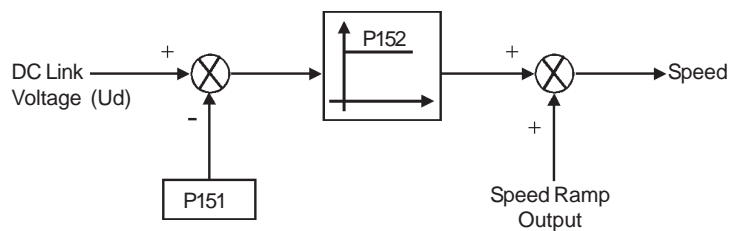



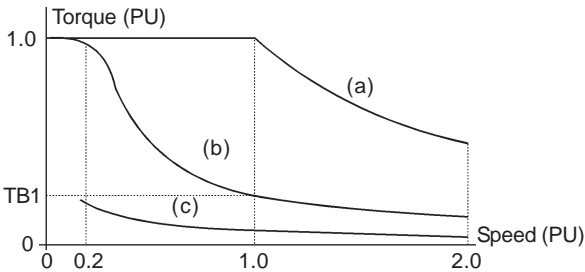

Figure 6.14 - Voltage Regulation Block Diagram of the DC-Link



**NOTE!**

For large motors it's recommended the use of the ramp holding function.

Parameter	Range [Factory Setting] Unit	Description / Notes
<b>P151</b> <sup>(6)</sup> DC Link Voltage Regulation Level with and without Optimal Braking <b>For Vector Control (P202=3 or 4)</b>	339 to 400 (P296=0) [ 400 ] 1V	<input checked="" type="checkbox"/> P151 defines the level for the DC link voltage regulation during braking. The time of the deceleration ramp is automatically extended, thus avoiding overvoltage error (E01).
	585 to 800 (P296=1) [ 800 ] 1V	<input checked="" type="checkbox"/> The DC link voltage regulation has two modes of operation: <ol style="list-style-type: none"> <li>1. With losses (Optimal braking) – set P150 to 0. In this mode the flux current is modulated so as to increase the losses in the motor, there by increasing the braking torque. It works better with lower efficiency motors (smaller motors). It is not recommended for motors bigger than 75HP/55kW. See explanation below.</li> <li>2. Without losses – set P150 to 1. Only the DC link voltage regulation is active.</li> </ol>
	616 to 800 (P296=2) [ 800 ] 1V	
	678 to 800 (P296=3) [ 800 ] 1V	
	739 to 800 (P296=4) [ 800 ] 1V	 <b>NOTE!</b> P151 factory setting is set at maximum this disables the DC link voltage regulation. To enable it, adjust according to table 6.7.
	809 to 1000 (P296=5) [ 1000 ] 1V	<b>Optimal Braking:</b> The Optimal Braking is a unique method of stopping the motor that provides more braking torque than DC Injection Braking without requiring Dynamic Braking components. In the case of DC Braking, except for the friction losses, only the rotor losses are used to dissipate the stored energy due to the driven mechanical load.
	885 to 1000 (P296=6) [ 1000 ] 1V	With Optimal Braking, both the total motor losses and the inverter losses are used. In this way, it is possible to achieve a braking torque of approximately 5 times higher than with the DC braking (Refer to Figure 6.15).
	924 to 1000 (P296=7) [ 1000 ] 1V	This feature allows high dynamic performance without the use of a Dynamic Braking resistor.
	1063 to 1200 (P296=8) [ 1200 ] 1V	Figure 6.15 shows a Torque x Speed curve of a typical 7.5 kW/10 HP, IV pole motor. The braking torque developed at full speed, with torque (P169 and P170) limited by the CFW-09 at a value equal to the motor rated torque, is given by TB1 point (figure 6.15).  TB1 value depends on the motor efficiency and disregarding the friction losses it is given by the following equation:
		$TB1 = \frac{1 - \eta}{\eta}$
		Where: $\eta$ = motor efficiency
		For the case in Figure 6.15, the motor efficiency at full load condition is 84% $\eta = 0.84$ , that results in $TB1 = 0.19$ or 19% of the motor rated torque. Starting at TB1 point, the braking torque varies in the reverse proportion of the speed (1/N). At low speeds, the braking torque reaches the torque limit level set by the inverter. For the case of Figure 6.15, the torque limit (100%) is reached when the speed is 20% of the rated speed.

Parameter	Range [Factory Setting] Unit	Description / Notes
		<p>The braking torque indicated in Figure 6.15 can be increased by increasing the inverter torque limit: P169 (maximum forward torque current) or P170 (maximum reverse torque current).</p> <p><input checked="" type="checkbox"/> In general, smaller motors have lower efficiency (higher losses) consequently Optimal Braking can achieve higher braking torques with smaller motors.</p> <p>Examples: 0.75 kW/1 HP, IV poles: <math>\eta = 0.76</math> that results in TB1= 0.32                      15 kW/20 HP, IV poles: <math>\eta = 0.86</math> that results in TB1= 0.16</p>  <p><b>Figure 6.15</b> - <math>T \times rpm</math> curve for optimal braking and typical 10HP/7.5kW motor driven by an inverter with torque limitation set for a value equal to the rated motor torque</p> <ul style="list-style-type: none"> <li>(a) Torque generated by the motor in normal operation, driven by an inverter in “motor mode”.</li> <li>(b) Braking torque generated by Optimal Braking</li> <li>(c) Braking torque generated with DC Injection Braking</li> </ul> <p><b>NOTE!</b>   The enabling of the optimal braking can increase the motor noise level and the vibration level. If this not desired, disable the optimal braking.</p>
<p><b>P152</b>                      Proportional Gain of the DC Link Voltage Regulator  <b>[Only for P202= 0, 1, 2 (V/F control) or 5 (VVW)]</b></p>	<p>0.00 to 9.99                      [ 0.00 ]                      0.01</p>	<ul style="list-style-type: none"> <li><input checked="" type="checkbox"/> Refer to P151 for V/F Control (Figure 6.14).</li> <li><input checked="" type="checkbox"/> If P152 = 0.00 and P151 is different from the maximum value, the Ramp Holding function is active. (See P151 for the Scalar Control Mode)</li> <li><input checked="" type="checkbox"/> P152 multiplies the DC link voltage error, i.e. DC link actual - DC link setting (P151). P152 is typically used to prevent overvoltage in applications with eccentric loads.</li> </ul>
<p><b>P153</b> <sup>(6)</sup>                      Dynamic Braking Voltage Level</p>	<p>339 to 400 (P296=0)                      [ 375 ]                      1V                      585 to 800 (P296=1)                      [ 618 ]                      1V                      616 to 800 (P296=2)                      [ 675 ]                      1V</p>	<ul style="list-style-type: none"> <li><input checked="" type="checkbox"/> Dynamic braking can only be used if the inverter is fitted with a dynamic braking resistor. The voltage level for actuation of the brake chopper must be set according to the supply voltage. If P153 is set too close to the overvoltage trip level (E01) an overvoltage trip may occur before the brake chopper and resistor can dissipate the braking energy. The following are the recommended settings:</li> </ul>

Parameter	Range [Factory Setting] Unit	Description / Notes																																			
	678 to 800 (P296=3) [ 748 ] 1V	<table border="1"> <thead> <tr> <th>Inverter <math>V_{nom}</math></th> <th>P296</th> <th>P153</th> <th>E01</th> </tr> </thead> <tbody> <tr> <td>220/230V</td> <td>0</td> <td>375V</td> <td>&gt; 400V</td> </tr> <tr> <td>380V</td> <td>1</td> <td>618V</td> <td rowspan="3">&gt; 800V</td> </tr> <tr> <td>400/415V</td> <td>2</td> <td>675V</td> </tr> <tr> <td>440/460V</td> <td>3</td> <td>748V</td> </tr> <tr> <td>480V</td> <td>4</td> <td>780V</td> <td rowspan="3">&gt; 1000V</td> </tr> <tr> <td>500/525V</td> <td>5</td> <td>893V</td> </tr> <tr> <td>550/575V</td> <td>6</td> <td>972V</td> </tr> <tr> <td>600V</td> <td>7</td> <td>972V</td> <td rowspan="2">&gt; 1200V</td> </tr> <tr> <td>660/690V</td> <td>8</td> <td>1174V</td> </tr> </tbody> </table>	Inverter $V_{nom}$	P296	P153	E01	220/230V	0	375V	> 400V	380V	1	618V	> 800V	400/415V	2	675V	440/460V	3	748V	480V	4	780V	> 1000V	500/525V	5	893V	550/575V	6	972V	600V	7	972V	> 1200V	660/690V	8	1174V
Inverter $V_{nom}$	P296		P153	E01																																	
220/230V	0		375V	> 400V																																	
380V	1		618V	> 800V																																	
400/415V	2		675V																																		
440/460V	3		748V																																		
480V	4		780V	> 1000V																																	
500/525V	5		893V																																		
550/575V	6	972V																																			
600V	7	972V	> 1200V																																		
660/690V	8	1174V																																			
	739 to 800 (P296=4) [ 780 ] 1V																																				
	809 to 1000 (P296=5) [ 893 ] 1V																																				
	885 to 1000 (P296=6) [ 972 ] 1V																																				
	924 to 1000 (P296=7) [ 972 ] 1V																																				
	1063 to 1200 (P296=8) [ 1174 ] 1V																																				
		<p><b>Table 6.8</b> - Recommended settings of the Dynamic Braking Actuation</p> <p><b>Figure 6.16</b> - Curve of the Dynamic Braking Actuation</p>																																			
		<p><input checked="" type="checkbox"/> To actuate the Dynamic Braking:</p> <p>⇒ Connect the DB resistor. Refer to Section 8</p> <p>⇒ Set P154 and P155 according to the size of the Dynamic braking resistor.</p> <p>⇒ Set P151 to its maximum value: 400V (P296=0), 800V (P296=1,2,3 or 4), 1000V (P296=5, 6 or 7) or 1200V (P296=8), to avoid actuation of the DC link Voltage Regulation before Dynamic Braking.</p>																																			
<b>P154</b> Dynamic Braking Resistor	0 to 500 [ 0 ] 0.1Ω (≤ 99.9)- 1Ω (≥ 100)	<p><input checked="" type="checkbox"/> Resistance value of the Dynamic Braking resistor (in ohms).</p> <p><input checked="" type="checkbox"/> P154 = 0 disables the braking resistor overload protection. Must be programmed to 0 when braking resistor is not used.</p>																																			
<b>P155</b> DB Resistor Power Rating	0.02 to 650 [ 2.60 ] 0.01kW (<9.99) 0.1kW (>9.99) 1kW(>99.9)	<p><input checked="" type="checkbox"/> Adjusts the overload protection for Dynamic Braking resistor. Set it according to the power rating of the DB resistor (in kW).</p> <p><input checked="" type="checkbox"/> If the average power in the braking resistor during 2 minutes is higher than the value set at P155, the inverter trips on an E12 fault.</p> <p><input checked="" type="checkbox"/> See item 8.10.</p>																																			

Parameter	Range [Factory Setting] Unit
<b>P156</b> <sup>(2)</sup> <sup>(7)</sup> <sup>(12)</sup> Motor Overload Current at 100% Speed	P157 to 1.3xP295 <sup>(12)</sup> [ 1.1xP401 ] 0.1A(<100)-1A(>99.9)
<b>P157</b> <sup>(2)</sup> <sup>(7)</sup> Motor Overload Current at 50% Speed	P156 to P158 [ 0.9xP401 ] 0.1A(<100)-1A(>99.9)
<b>P158</b> <sup>(2)</sup> <sup>(7)</sup> Motor Overload Current at 5% Speed	0.2xP295 to P157 [ 0.55xP401 ] 0.1A(<100)-1A(>99.9)

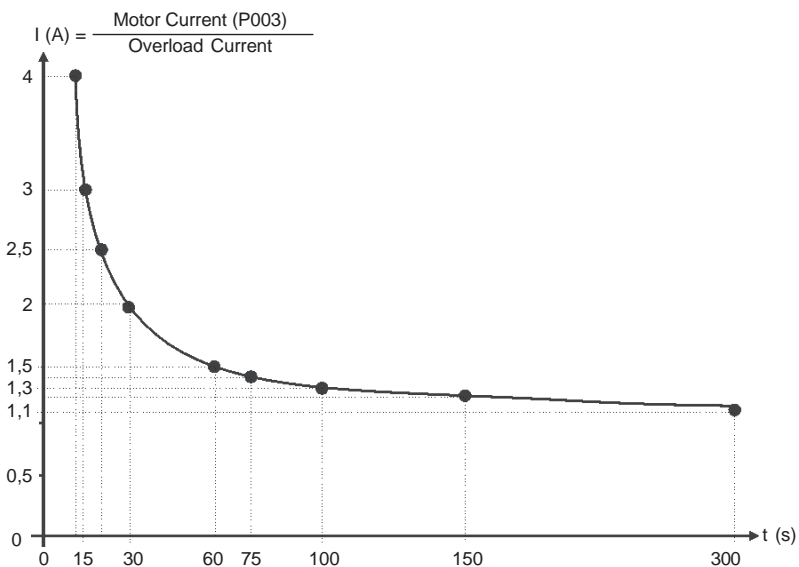

Figure 6.17 - Ixt Function - Overload detection

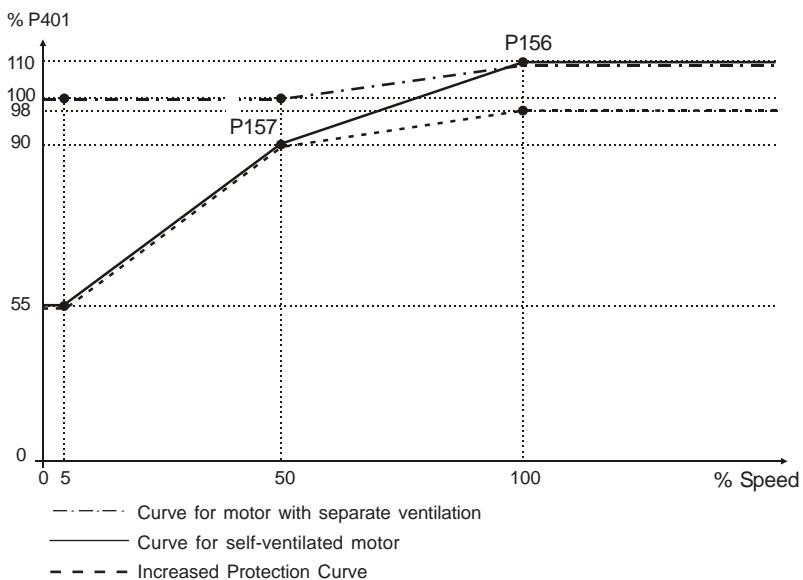

Figure 6.18 - Overload protection levels

- Used to protect motor and inverter against timed overload (I x t - E05).
- The Motor Overload Current (P156, P157 and P158) is the current level above which the CFW-09 will consider the motor operating under overload. The higher the overload, the sooner the Overload Fault E05 will occur.
- Parameter P156 (motor overload current at base speed) must be set 10% higher than the used rated motor current (P401).
- The overload current is given as a function of the motor speed. The parameters P156, P157 and P158 are the three points used to form the overload curve, as shown in Figure 6.18 with the factory default levels.

Parameter	Range [Factory Setting] Unit	Description / Notes
		<ul style="list-style-type: none"> <li>☑ This overload curve adjustment improves the protection of self-ventilated motors, or it can be programmed with a constant overload level at any speed for blower cooled motors.</li> <li>☑ This curve is changed when P406 (Ventilation Type) is changed during the start-up subroutine. (See 5.2).</li> </ul>

**P160**  
Optimization of the  
Speed Regulator  
(for torque control)

0 to 1  
[ 0 ]  
-

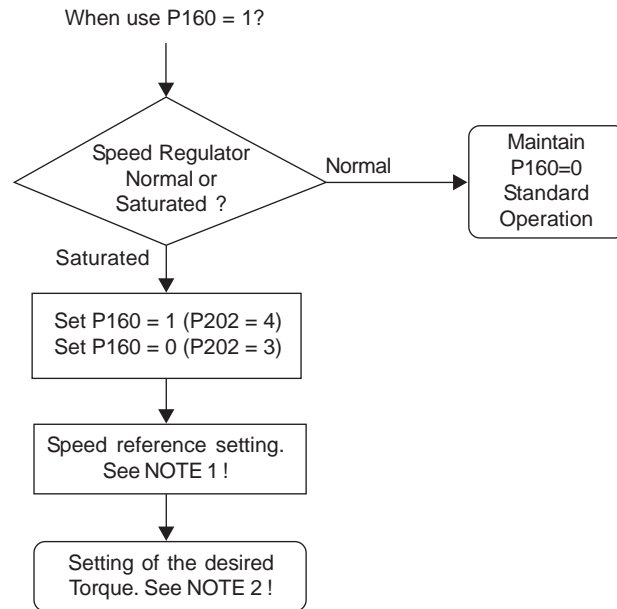

Figure 6.19 - Torque Control

**Speed Regulator operating with Current Limitation (Saturated) for torque limitation purposes**

- ☑ The speed reference shall be set to value at least 10% higher than the working speed. It ensures that the output of the speed regulator will be equal to the maximum allowed value set for the maximum torque current (P169, or P170, or external limitation through AI2 or AI3). In such way, the regulator will operate with current limitation, i.e., saturated.
- ☑ When the speed regulator is positively saturated, i.e., in the forward direction (set in P223/P226), the value for the torque current limitation is set at parameter P169.
- ☑ When the speed regulator is negatively saturated, i.e., in the reverse direction (set in P223/P226), the value for the torque current limitation is set at parameter P170.
- ☑ The torque limitation with the saturated speed regulator has also a protection function (limitation). For instance: in a winder, if the winding material is disrupted, then the regulator leaves the saturated condition and starts controlling the motor speed, which will be limited by the speed reference value.

Parameter	Range [Factory Setting] Unit	Description / Notes
		<p><b>Torque limitation settings</b></p> <ul style="list-style-type: none"> <li><input checked="" type="checkbox"/> The torque can be limited as follows:               <ol style="list-style-type: none"> <li>1. Through parameters P169/P170 (by using the keypad, the Serial Wegbus protocol or the Fieldbus protocols)</li> <li>2. Through AI2 (P237 = 2 - Maximum torque current)</li> <li>3. Through AI3 (P241 = 2 - Maximum torque current)</li> </ol> </li> <li>Notes:               <ul style="list-style-type: none"> <li><input checked="" type="checkbox"/> The motor current shall be equivalent to the CFW-09 drive current so that the torque control can achieve its best precision.</li> <li><input checked="" type="checkbox"/> The sensorless control (P202=3) does not work with torque limitation at frequencies lower than 3Hz. Use the vector with encoder control (P202=4) for applications that require torque limitation at frequencies lower than 3Hz.</li> <li><input checked="" type="checkbox"/> The torque limitation (P169/P170) shall be greater than 30% in order to guarantee the motor start in the sensorless mode (P202=3). After the motor has started and it is running above 3Hz, the torque limitation value (P169/P170) may be reduced below 30%, if required.</li> <li><input checked="" type="checkbox"/> The motor torque (<math>T_{motor}</math>) can be calculated from the value at P169/P170 by using the following equation:</li> </ul> </li> </ul> $T_{motor} = \left( \frac{P295 \times \frac{P169^*}{100} \times K}{\sqrt{(P401)^2 - \left( P410 \times \frac{P178}{100} \right)^2}} \right) \times 100$ <p>where:</p> <p><math>T_{motor}</math> - Percentage value of the rated motor torque.</p> $K = \begin{cases} 1 & \text{for } N \leq N_{rated} \\ \frac{N_{rated}}{N} \times \frac{P180}{100} & \text{for } N > N_{rated} \end{cases}$ <p><math>N_{nom}</math> = Motor synchronous speed  <math>N</math> = Motor actual speed            * NOTE: The above equation is valid for forward torque. To reverse torque, replace P169 by P170.</p>

Parameter	Range [Factory Setting] Unit	Description / Notes
<b>P161</b> <sup>(3)</sup> Proportional Gain of the Speed Regulator	0.0 to 63.9 [ 7.4 ] 0.1	<input checked="" type="checkbox"/> The gains for the speed regulator are automatically set based on the value of parameter P413 (Tm Constant). <input checked="" type="checkbox"/> However, these gains can be manually adjusted in order to optimize the dynamic response of the speed. Increase this value to have a faster response. Although, reduce this value in case of speed oscillations.
<b>P162</b> <sup>(3)</sup> Integral Gain of the Speed Regulator	0.000 to 9.999 [ 0.023 ] 0.001	<input checked="" type="checkbox"/> In general, P161 smoothes abrupt changes of speed or reference, while P162 reduces the error between the set point and the real speed value, as well as improves the torque response at low speeds. <input checked="" type="checkbox"/> Optimization of the Speed Regulator – Procedure for manual setting:

- 1 - Select the acceleration (P100) and/or deceleration (P101) time according to the application;
- 2 - Set the speed reference to 75% of the maximum value;
- 3 - Configure the analog output AO3 or AO4 to Real Speed by setting P255 or P257 to 2.
- 4 - Block the speed ramp – Start/Stop = Stop and wait until the motor stops;
- 5 - Release the speed ramp – Start/Stop = Start; observe the motor speed signal at the analog output AO3 or AO4 with an oscilloscope;
- 6 - Check among the options in figure 6.20 which waveform best represents the signal measured with the oscilloscope.

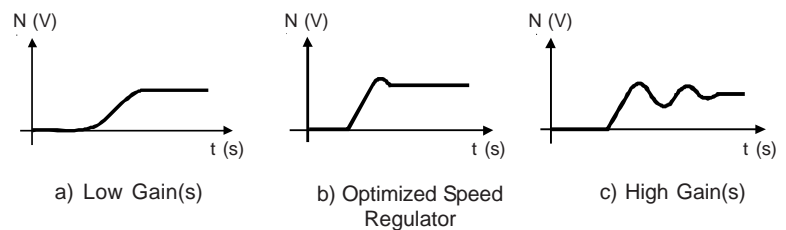









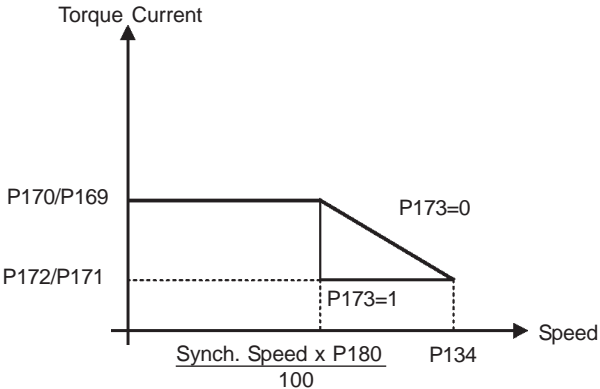

Figure 6.20 - Types of response for the Speed Regulator.

Settings of P161 and P162 as a function of the type of response presented in figure 6.20:

- a) Increase the proportional gain (P161), and/or increase the integral gain (P162).
- b) Speed regulator is optimized.
- c) Decrease the proportional gain (P161), and/or decrease the integral gain (P162).

Parameter	Range [Factory Setting] Unit	Description / Notes						
<b>P163</b> Offset value for the Local Reference #1  <b>P164</b> Offset value for the Remote Reference #1   <b>These parameters (P160 to P164) are shown on the display(s) only when P202 = 3 or 4 (Vector Control)</b>	-999 to 999 [ 0 ] 1  -999 to 999 [ 0 ] 1	<input checked="" type="checkbox"/> Parameters P163 or P164 may be used to compensate a bias offset at the analog input signals, when the speed reference is given by the analog inputs (AI1 to AI4).  <input checked="" type="checkbox"/> Refer to figure 6.26.						
<b>P165</b> Speed Filter   <b>This parameter is shown on the display(s) only when P202 = 3 or 4 (Vector Control)</b>	0.012 to 1.000s [ 0.012s ] 0.001s	<input checked="" type="checkbox"/> Adjusts the time constant for the Speed Filter. Refer to figure 6.27 a).   <b>NOTE!</b> In general, this parameter shall not be changed. Increasing the speed filter value renders the system response slower.						
<b>P166</b> Speed Regulator Differential Gain   <b>This parameter is shown on the display(s) only when P202 = 3 or 4 (Vector Control)</b>	0.00 to 7.99 [ 0.00 ] -	<input checked="" type="checkbox"/> The differential action may reduce the effects on the motor speed caused by the load variation. Refer to figure 6.27 a).  <table border="1" data-bbox="756 1205 1292 1297"> <thead> <tr> <th>P166</th> <th>Differential Gain Action</th> </tr> </thead> <tbody> <tr> <td>0.0</td> <td>Off</td> </tr> <tr> <td>0.01 to 7.99</td> <td>On</td> </tr> </tbody> </table> <p style="text-align: center;"><i>Table 6.9 - Speed Regulator Differential Gain Action</i></p>	P166	Differential Gain Action	0.0	Off	0.01 to 7.99	On
P166	Differential Gain Action							
0.0	Off							
0.01 to 7.99	On							
<b>P167</b> <sup>(4)</sup> Proportional Gain of the Current Regulator  <b>P168</b> <sup>(4)</sup> Integral Gain of the Current Regulator   <b>Parameters (P166 and P167 and P168) are shown on the display(s) only when P202 = 3 or 4 (Vector Control)</b>	0.00 to 1.99 [ 0.5 ] 0.01  0.000 to 1.999 [ 0.010 ] 0.001	<input checked="" type="checkbox"/> The parameters P167 and P168 are set by the self-tuning routine as a function of parameters P411 and P409, respectively.   <b>NOTE!</b> These parameters must not be changed.						

Parameter	Range [Factory Setting] Unit	Description / Notes
<b>P169</b> <sup>(7)</sup> Maximum Output Current For V/F Control (P202=0, 1, 2 or 5)	0.2xP295 to 1.8xP295 [ 1.5xP295 ] 0.1A(<100) -1A(>99.9)	<ul style="list-style-type: none"> <li>☑ This parameter limits the motor output current by reducing the speed, which avoids motor stalling under overload conditions.</li> <li>☑ As the motor load increases, the motor current also increases. When this current exceeds the value set at parameter P169, the motor speed is reduced (by using the deceleration ramp) until the current value falls below the value set at P169. The motor speed is resumed when the overload condition stops.</li> </ul> <div style="text-align: center;"> <p>Figure 6.21 - Curves showing the actuation of the current limitation</p> </div>
<b>P169</b> <sup>(7)</sup> Maximum Forward Torque Current For Vector Control (P202 = 3 or 4)	0 to 180 [ 125 ] 1%	<ul style="list-style-type: none"> <li>☑ This parameter limits the value of the component of the motor current that produces forward torque. The setting is expressed as a percentage value of the drive rated current (P295=100%).</li> <li>☑ The values of P169/P170 can be calculated from the maximum desired value for the motor current (<math>I_{motor}</math>) by using the following equation:</li> </ul> $P169/P170(\%) = \sqrt{\left(\frac{100 \times I_{motor}}{P295}\right)^2 - \left(\frac{100 \times P410}{P295}\right)^2}$
<b>P170</b> Maximum Reverse Torque Current  ☞ This parameters (P169 and P170) are shown on the display(s) only when P202 = 3 or 4 (Vector Control)	0 to 180 [ 125 ] 1%	<ul style="list-style-type: none"> <li>☑ This parameter limits the value of the component of the motor current that produces reverse torque. While operating in torque limitation, the motor current can be calculated by:</li> </ul> $I_{motor} = \sqrt{\left(\frac{P169 \text{ or } P170}{100} \times P295\right)^2 + (P410)^2}$

Parameter	Range [Factory Setting] Unit	Description / Notes						
		<p><input checked="" type="checkbox"/> The maximum torque produced by the motor is given by:</p> $T_{\text{motor}} (\%) = \left( \frac{P295 \times \frac{P169}{100} \times K}{\sqrt{(P401)^2 - \left( P410 \times \frac{P178}{100} \right)^2}} \right) \times 100$ <p>where:</p> $K = \begin{cases} 1 & \text{for } N \leq N_{\text{rated}} \\ \frac{N_{\text{rated}}}{N} \times \frac{P180}{100} & \text{for } N > N_{\text{rated}} \end{cases}$ <p><input checked="" type="checkbox"/> While the Optimal Braking is operating, P169 limits the maximum output current in order to produce the braking forward torque (refer to P151). See the above description for P169.</p>						
<p><b>P171</b> Maximum Forward Torque Current at the Maximum Speed (N = P134)</p> <p><b>P172</b> Maximum Reverse Torque Current at the Maximum Speed (N = P134)</p> <p> <b>These parameters (P171 and P172) are shown on the display(s) only when P202 = 3 or 4 (Vector Control)</b></p>	<p>0 to 180 [ 125 ] 1%</p> <p>0 to 180 [ 125 ] 1%</p>	<p><input checked="" type="checkbox"/> Torque current limitation as a function of the speed:</p>  <p><i>Figure 6.22 – Operation curve of the torque limitation at maximum speed</i></p> <p><input checked="" type="checkbox"/> This function is disabled while the value of P171/P172 is equal to or greater than the value of P169/170.</p> <p><input checked="" type="checkbox"/> P171 and P172 operate also during the optimal braking by limiting the maximum output current.</p>						
<p><b>P173</b> Type of Curve for the Maximum Torque</p> <p> <b>This parameter is show on the display(s) only when P202 = 3 or 4 (Vector Control)</b></p>	<p>0 to 1 [ 0 ] -</p>	<p><input checked="" type="checkbox"/> It defines the operation curve of the torque limitation at the field-weakening region. Refer to figure 6.22.</p> <table border="1" data-bbox="781 1797 1273 1906"> <thead> <tr> <th>P173</th> <th>Curve Type</th> </tr> </thead> <tbody> <tr> <td>0</td> <td>Ramp</td> </tr> <tr> <td>1</td> <td>Step</td> </tr> </tbody> </table> <p><i>Table 6.10 - Curve Type of the Maximum Torque</i></p>	P173	Curve Type	0	Ramp	1	Step
P173	Curve Type							
0	Ramp							
1	Step							





Parameter	Range [Factory Setting] Unit	Description / Notes									
<b>P175</b> <sup>(5)</sup> Proportional Gain of the Flux Regulator	0.0 to 31.9 [ 2.0 ] 0.1	<input checked="" type="checkbox"/> P175 and P176 are automatically set as a function of parameter P412. In general the automatic setting is adequate and there is no need for a reconfiguration.									
<b>P176</b> <sup>(5)</sup> Integral Gain of the Flux Regulator	0.000 to 9.999 [ 0.020 ] 0.001	<input checked="" type="checkbox"/> These gains shall only be manually reconfigured when the excitation current signal (id*) is oscillating and compromising system operation.									
 <b>NOTE!</b> The excitation current (id*) may be unstable in case of P175 > 12.											
<b>Note:</b> (id*) can be observed at analog outputs AO3 and /or AO4 by setting P255=14 and / or P257=14, or at P29 and / or P30.											
<b>P177</b> Minimum Flux	0 to 120 [ 0 ] 1%	<input checked="" type="checkbox"/> Parameters P177 and P179 define the output limits of the flux regulator in the Sensorless Vector control.									
<b>P178</b> Rated Flux	0 to 120 [ 100 ] 1%	 <b>NOTE!</b> These parameters shall not be changed.									
<b>P179</b> Maximum Flux	0 to 120 [ 120 ] 1%	<input checked="" type="checkbox"/> P178 is the flux reference to both Vector controls (sensorless and with encoder).									
 <b>P177 to P179 are active only when P202=3 (Sensorless Vector)</b>											
<b>P180</b> Starting Point of the Field Weakening Region	0 to 120 [ 95 ] 1%	<input checked="" type="checkbox"/> This parameter is represented as a percentage of the motor rated speed (P402) and defines the speed where the field weakening region of the motor starts.									
 <b>These parameters (P175, P176, P178 and P180) are shown on the display(s) only when P202 = 3 or 4 (Vector Control)</b>											
<b>P181</b> Magnetization Mode	0,1 [ 0 ] -	<table border="1"> <thead> <tr> <th>P181</th> <th>Function</th> <th>Action</th> </tr> </thead> <tbody> <tr> <td>0</td> <td>General Enable</td> <td>It applies magnetization current after General Enable ON</td> </tr> <tr> <td>1</td> <td>Start/Stop</td> <td>It applies magnetization current after Start/Stop ON</td> </tr> </tbody> </table>	P181	Function	Action	0	General Enable	It applies magnetization current after General Enable ON	1	Start/Stop	It applies magnetization current after Start/Stop ON
P181	Function	Action									
0	General Enable	It applies magnetization current after General Enable ON									
1	Start/Stop	It applies magnetization current after Start/Stop ON									
 <b>This parameter is shown on the display only when P202 = 4 (Vector Control with Encoder)</b>											
<input checked="" type="checkbox"/> In sensorless vector, magnetization current is permanently ON. To disable magnetization current when the motor is stopped, program P211 to 1 (ON). This can be given a time delay by programming P213 greater than zero.											

Table 6.11 - Magnetization Mode

6.3 CONFIGURATION PARAMETERS - P200 to P399

Parameter	Range [Factory Setting] Unit	Description / Notes														
<b>P200</b> Password	0,1 [ 1 ] -	<table border="1"> <thead> <tr> <th>P200</th> <th>Function</th> <th>Result</th> </tr> </thead> <tbody> <tr> <td>0</td> <td>Off</td> <td>Disables the Password and allows changing parameters content independently of P000.</td> </tr> <tr> <td>1</td> <td>On</td> <td>Enables the Password and allows changing parameters content only when P000 is set to the password value.</td> </tr> </tbody> </table> <p style="text-align: center;"><b>Table 6.12 - Password</b></p> <p> <input checked="" type="checkbox"/> The factory default for the password is P000 = 5.  <input checked="" type="checkbox"/> To change the password refer to P000.                 </p>	P200	Function	Result	0	Off	Disables the Password and allows changing parameters content independently of P000.	1	On	Enables the Password and allows changing parameters content only when P000 is set to the password value.					
		P200	Function	Result												
0	Off	Disables the Password and allows changing parameters content independently of P000.														
1	On	Enables the Password and allows changing parameters content only when P000 is set to the password value.														
<b>P201</b> <sup>(11)</sup> Language Selection	0 to 3 [ - ] -	<table border="1"> <thead> <tr> <th>P201</th> <th>Language</th> </tr> </thead> <tbody> <tr> <td>0</td> <td>Português</td> </tr> <tr> <td>1</td> <td>English</td> </tr> <tr> <td>2</td> <td>Español</td> </tr> <tr> <td>3</td> <td>Deutsch</td> </tr> </tbody> </table> <p style="text-align: center;"><b>Table 6.13 - Language selection</b></p>	P201	Language	0	Português	1	English	2	Español	3	Deutsch				
		P201	Language													
0	Português															
1	English															
2	Español															
3	Deutsch															
<b>P202</b> <sup>(1) (2) (11)</sup> Type of control	0 to 5 [ 0 ] -	<table border="1"> <thead> <tr> <th>P202</th> <th>Type of Control</th> </tr> </thead> <tbody> <tr> <td>0</td> <td>V/F 60Hz</td> </tr> <tr> <td>1</td> <td>V/F 50Hz</td> </tr> <tr> <td>2</td> <td>V/F Adjustable (Refer to P142 to P146)</td> </tr> <tr> <td>3</td> <td>Sensorless Vector</td> </tr> <tr> <td>4</td> <td>Vector with Encoder</td> </tr> <tr> <td>5</td> <td>VVW (Voltage Vector WEG)</td> </tr> </tbody> </table> <p style="text-align: center;"><b>Table 6.14 - Type of control selection</b></p> <p> <input checked="" type="checkbox"/> For details on the Type of Control selection Refer to Section 5.3.                 </p>	P202	Type of Control	0	V/F 60Hz	1	V/F 50Hz	2	V/F Adjustable (Refer to P142 to P146)	3	Sensorless Vector	4	Vector with Encoder	5	VVW (Voltage Vector WEG)
		P202	Type of Control													
0	V/F 60Hz															
1	V/F 50Hz															
2	V/F Adjustable (Refer to P142 to P146)															
3	Sensorless Vector															
4	Vector with Encoder															
5	VVW (Voltage Vector WEG)															
<b>P203</b> <sup>(1)</sup> Special Function Selection	0,1 [ 0 ] -	<p> <input checked="" type="checkbox"/> It defines the selection type of special functions:                 </p> <table border="1"> <thead> <tr> <th>P203</th> <th>Functions</th> </tr> </thead> <tbody> <tr> <td>0</td> <td>Not Used</td> </tr> <tr> <td>1</td> <td>PID Regulator</td> </tr> </tbody> </table> <p style="text-align: center;"><b>Table 6.15 - Special Function selection</b></p> <p> <input checked="" type="checkbox"/> For the special function of PID regulator, see detailed description of related parameters (P520 to P535).  <input checked="" type="checkbox"/> When P203 is changed to 1, P265 is changed automatically to 15 - Manual/Auto.                 </p>	P203	Functions	0	Not Used	1	PID Regulator								
		P203	Functions													
0	Not Used															
1	PID Regulator															

Parameter	Range [Factory Setting] Unit	Description / Notes
P204 <sup>(1)</sup> <sup>(10)</sup> Load/Save Parameters	0 to 11 [ 0 ] -	<ul style="list-style-type: none"> <li>☑ The parameters P295 (Inverter Rated Current), P296 (Inverter Rated Voltage), P297 (Switching Frequency), P308 (Serial Address) and P201 (Language) are not changed when the factory default parameters are loaded through P204 = 5 and 6.</li> <li>☑ In order to load the User Parameters #1 (P204=7) and/or the User Parameters #2 (P204=8) into the operation area of the CFW-09, it is necessary that the User Memory #1 and/or the User Memory #2 have been previously saved (P204=10 and/or P204=11).</li> <li>☑ Once entered the user parameters are automatically saved to the VSD EEPROM. In addition it is possible to save two further sets of parameters, or to use these as a “backup”.</li> <li>☑ The operation of Load User 1 and/or 2 can also be done by DIx (See parameters P265 to P269).</li> <li>☑ The options P204=5, 6, 7, 8, 10 and 11 are disables when P309 ≠ 0 (Active Fieldbus).</li> </ul>

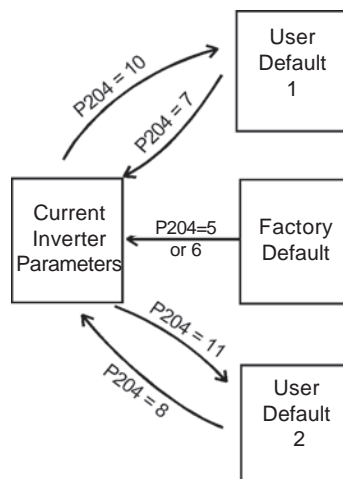

Figure 6.23 - Parameter Transference

Parameter	Range [Factory Setting] Unit	Description / Notes																				
		<table border="1"> <thead> <tr> <th>P204</th> <th>Action</th> </tr> </thead> <tbody> <tr> <td>0, 1, 2, 9</td> <td><b>Not Used:</b> No action</td> </tr> <tr> <td>3</td> <td><b>Reset P043:</b> Resets the Time Enabled hour meter to zero</td> </tr> <tr> <td>4</td> <td><b>Reset P044:</b> Resets the kWh counter to zero</td> </tr> <tr> <td>5</td> <td><b>Load WEG-60Hz:</b> Resets all parameters to the 60Hz factory default values.</td> </tr> <tr> <td>6</td> <td><b>Load WEG-50Hz:</b> Resets all parameters to the 50Hz factory default values.</td> </tr> <tr> <td>7</td> <td><b>Load User 1:</b> Resets all parameters to the values stored in Parameter Memory 1.</td> </tr> <tr> <td>8</td> <td><b>Load user 2:</b> Resets all parameters to the value stored in Parameter Memory 2.</td> </tr> <tr> <td>10</td> <td><b>Save User 1:</b> Stores all current inverter parameter values to Parameter Memory 1.</td> </tr> <tr> <td>11</td> <td><b>Save User 2:</b> Stores all current inverter parameter values to Parameter Memory 2.</td> </tr> </tbody> </table>	P204	Action	0, 1, 2, 9	<b>Not Used:</b> No action	3	<b>Reset P043:</b> Resets the Time Enabled hour meter to zero	4	<b>Reset P044:</b> Resets the kWh counter to zero	5	<b>Load WEG-60Hz:</b> Resets all parameters to the 60Hz factory default values.	6	<b>Load WEG-50Hz:</b> Resets all parameters to the 50Hz factory default values.	7	<b>Load User 1:</b> Resets all parameters to the values stored in Parameter Memory 1.	8	<b>Load user 2:</b> Resets all parameters to the value stored in Parameter Memory 2.	10	<b>Save User 1:</b> Stores all current inverter parameter values to Parameter Memory 1.	11	<b>Save User 2:</b> Stores all current inverter parameter values to Parameter Memory 2.
P204	Action																					
0, 1, 2, 9	<b>Not Used:</b> No action																					
3	<b>Reset P043:</b> Resets the Time Enabled hour meter to zero																					
4	<b>Reset P044:</b> Resets the kWh counter to zero																					
5	<b>Load WEG-60Hz:</b> Resets all parameters to the 60Hz factory default values.																					
6	<b>Load WEG-50Hz:</b> Resets all parameters to the 50Hz factory default values.																					
7	<b>Load User 1:</b> Resets all parameters to the values stored in Parameter Memory 1.																					
8	<b>Load user 2:</b> Resets all parameters to the value stored in Parameter Memory 2.																					
10	<b>Save User 1:</b> Stores all current inverter parameter values to Parameter Memory 1.																					
11	<b>Save User 2:</b> Stores all current inverter parameter values to Parameter Memory 2.																					

Table 6.16 - Action of loading/saving parameters

 **NOTE!**

The action of loading/saving parameters will take effect only after P204 has been set and the  key is pressed.

<b>P205</b> Display Default	0 to 7 [ 2 ] -	<input checked="" type="checkbox"/> Selects which of the parameters listed below will be shown on the display as a default after the inverter has been powered up:
--------------------------------	----------------------	--



P205	Display Default
0	P005 (Motor Frequency)
1	P003 (Motor Current)
2	P002 (Motor Speed)
3	P007 (Motor Voltage)
4	P006 (Inverter Status)
5	P009 (Motor Torque)
6	P070 (motor speed and motor current)
7	P040 (PID Process Variable)

Table 6.17 - Options displays default





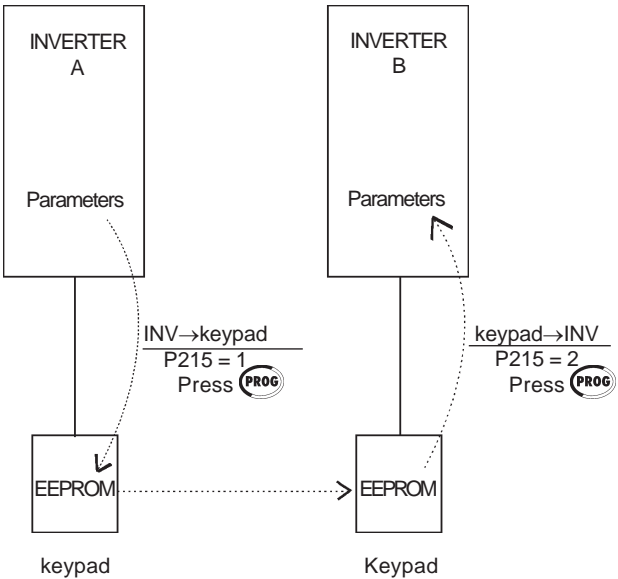

Parameter	Range [Factory Setting] Unit	Description / Notes																					
<b>P206</b> Auto-Reset Time	0 to 255 [ 0 ] 1s	<ul style="list-style-type: none"> <li><input checked="" type="checkbox"/> In the event of a fault trip, except for E09, E24, E31 and E41, the CFW-09 can initiate an automatic reset after the time given by P206 is elapsed.</li> <li><input checked="" type="checkbox"/> If <math>P206 \leq 2</math> Auto-Reset does not occur.</li> <li><input checked="" type="checkbox"/> If after Auto-Reset the same fault is repeated three times consecutively, the Auto-Reset function will be disabled. A fault is considered consecutive if it happens again within 30 seconds after Auto-Reset.</li> <li><input checked="" type="checkbox"/> Hence, if an error occurs four consecutive times, it will be permanently indicated (and the drive will be disabled).</li> </ul>																					
<b>P207</b> Reference Engineering Unit 1	32 to 127 [ 114 (r) ] -	<ul style="list-style-type: none"> <li><input checked="" type="checkbox"/> This parameter is useful only for inverters provided with a keypad with LCD display.</li> <li><input checked="" type="checkbox"/> P207 is used to apply a customised display to P001 (Speed reference) and P002 (motor speed). The letters rpm can be changed to user selected characters, E.g. CFM, L/s, etc.</li> <li><input checked="" type="checkbox"/> The Reference Engineering Unit is formed by three characters, which will be applied to the Speed Reference (P001) and the Motor Speed (P002) LCD display indications. P207 defines the left character. P216 defines the center character and P217 the right character.</li> <li><input checked="" type="checkbox"/> All characters correspondent to the ASCII code from 32 to 127 can be chosen. Examples: A, B, ... , Y, Z, a, b, ... , y, z, 0, 1, ... , 9, #, \$, %, (, ), *, +, ...</li> </ul>																					
<b>P208</b> <sup>(2)</sup> <sup>(11)</sup> Reference Scale Factor	1 to 18000 [ 1800 (1500) <sup>(11)</sup> ] 1	<ul style="list-style-type: none"> <li><input checked="" type="checkbox"/> Defines how the Speed Reference (P001) and the Motor Speed (P002) will be displayed.</li> <li><input checked="" type="checkbox"/> <b>For indicating the values in rpm:</b> Set the synchronous speed according to the following table.</li> </ul> <table border="1" style="margin-left: auto; margin-right: auto;"> <thead> <tr> <th>Frequency</th> <th>Motor Pole Number</th> <th>Synchronous Speed - rpm</th> </tr> </thead> <tbody> <tr> <td rowspan="4" style="text-align: center;">50Hz</td> <td style="text-align: center;">2</td> <td style="text-align: center;">3000</td> </tr> <tr> <td style="text-align: center;">4</td> <td style="text-align: center;">1500</td> </tr> <tr> <td style="text-align: center;">6</td> <td style="text-align: center;">1000</td> </tr> <tr> <td style="text-align: center;">8</td> <td style="text-align: center;">750</td> </tr> <tr> <td rowspan="4" style="text-align: center;">60Hz</td> <td style="text-align: center;">2</td> <td style="text-align: center;">3600</td> </tr> <tr> <td style="text-align: center;">4</td> <td style="text-align: center;">1800</td> </tr> <tr> <td style="text-align: center;">6</td> <td style="text-align: center;">1200</td> </tr> <tr> <td style="text-align: center;">8</td> <td style="text-align: center;">900</td> </tr> </tbody> </table> <p style="text-align: center;"><i>Table 6.18 - Synchronous speed reference in rpm</i></p> <ul style="list-style-type: none"> <li><input checked="" type="checkbox"/> <b>For indicating other values:</b> The displayed value when the motor is running at synchronous speed can be calculated through the following equations: <math>P002 = \text{Speed} \times P208 / \text{Sync speed} \times (10)^{P210}</math></li> </ul>	Frequency	Motor Pole Number	Synchronous Speed - rpm	50Hz	2	3000	4	1500	6	1000	8	750	60Hz	2	3600	4	1800	6	1200	8	900
Frequency	Motor Pole Number	Synchronous Speed - rpm																					
50Hz	2	3000																					
	4	1500																					
	6	1000																					
	8	750																					
60Hz	2	3600																					
	4	1800																					
	6	1200																					
	8	900																					

Parameter	Range [Factory Setting] Unit	Description / Notes						
		<p><math>P001 = \text{Reference} \times P208 / \text{Sync speed} \times (10)^{P210}</math></p> <p>Where:</p> <p>Reference = Speed Reference in rpm.</p> <p>Speed = Motor speed in rpm;</p> <p>Sync Speed = Motor synchronous speed (<math>120 \times P403 / \text{Poles}</math>);</p> <p>Poles = Motor number of poles (<math>120 \times P403 / P402</math>);</p> <p>Example:</p> <p>Desired indication: 90.0 l/s at 1800 rpm</p> <p>Motor synchronous speed: 1800 rpm</p> <p>Programming: P208 = 900, P210 = 1, P207 = l, P216 = /, P217 = s</p>						
<p><b>P209</b><sup>(1)</sup> Motor Phase Loss Detection</p>	<p>0,1 [ 0 ] -</p>	<table border="1"> <thead> <tr> <th>P209</th> <th>Motor Phase Loss (E15)</th> </tr> </thead> <tbody> <tr> <td>0</td> <td>Off</td> </tr> <tr> <td>1</td> <td>On</td> </tr> </tbody> </table> <p><b>Table 6.19 - Actuation Motor Phase Loss Detection</b></p> <p><input checked="" type="checkbox"/> With the Motor Phase Loss Detector enabled (P209=1), E15 happens when the following conditions occur simultaneously during a minimum time of 2 seconds:</p> <ol style="list-style-type: none"> <li>P209 = On;</li> <li>Inverter enabled;</li> <li>Speed reference higher than 3%;</li> <li><math> I_u - I_v  &gt; 0.125 \times P401</math> or <math> I_u - I_w  &gt; 0.125 \times P401</math> or <math> I_v - I_w  &gt; 0.125 \times P401</math>.</li> </ol>	P209	Motor Phase Loss (E15)	0	Off	1	On
P209	Motor Phase Loss (E15)							
0	Off							
1	On							
<p><b>P210</b> Decimal point of the Speed Indication</p>	<p>0 to 3 [ 0 ] 1</p>	<p><input checked="" type="checkbox"/> Defines the number of digits after the decimal point of the Speed Reference (P001) and the Motor Speed indications (P002).</p>						
<p><b>P211</b><sup>(1)</sup> Zero Speed Disable</p>	<p>0,1 [ 0 ] -</p>	<table border="1"> <thead> <tr> <th>P211</th> <th>Zero Speed Disable</th> </tr> </thead> <tbody> <tr> <td>0</td> <td>Off</td> </tr> <tr> <td>1</td> <td>On</td> </tr> </tbody> </table> <p><b>Table 6.20 - Zero Speed Disable</b></p> <p><input checked="" type="checkbox"/> When active, it disables (general disabling, motor runs freely) the inverter when the speed reference and the actual motor speed are lower than the value set at P291 (Zero Speed Zone).</p> <p><input checked="" type="checkbox"/> The CFW-09 will be enabled again, when one of the conditions defined by the Parameter P212 is satisfied.</p>	P211	Zero Speed Disable	0	Off	1	On
P211	Zero Speed Disable							
0	Off							
1	On							

Parameter	Range [Factory Setting] Unit	Description / Notes								
<b>P212</b> Condition to Leave Zero Speed Disable	0 or 1 [ 0 ] -	<table border="1"> <thead> <tr> <th>P212 (P211=1)</th> <th>Inverter leaves zero speed disable if</th> </tr> </thead> <tbody> <tr> <td>0</td> <td>P001 (Speed ref. N*) &gt; P291 or P002 (Motor speed N) &gt; P291</td> </tr> <tr> <td>1</td> <td>P001 (Speed ref. N*) &gt; P291</td> </tr> </tbody> </table>	P212 (P211=1)	Inverter leaves zero speed disable if	0	P001 (Speed ref. N*) > P291 or P002 (Motor speed N) > P291	1	P001 (Speed ref. N*) > P291		
		P212 (P211=1)	Inverter leaves zero speed disable if							
0	P001 (Speed ref. N*) > P291 or P002 (Motor speed N) > P291									
1	P001 (Speed ref. N*) > P291									
<p><b>Table 6.21 - Condition to Leave Zero Speed Disable</b></p> <p><input checked="" type="checkbox"/> When the PID Regulator is active (P203=1) and in Automatic mode, the inverter leaves the Zero Speed, besides the programmed condition in P212, only when the PID input error (the difference between setpoint and process variable) is higher than the value programmed in P535.</p>										
<b>P213</b> Time Delay for Zero Speed Disable	0 to 999 [ 0 ] 1s	<p><input checked="" type="checkbox"/> P213=0: Zero speed disable without timing.</p> <p><input checked="" type="checkbox"/> P213&gt;0: Zero speed disable will only become active after the time delay set in P213. Timing starts when the zero speed zone conditions are met. If these conditions are no longer met during the delay time, the timer will reset.</p>								
<b>P214</b> <sup>(1) (9)</sup> Line Phase Loss Detection	0 or 1 [ 1 ] -	<table border="1"> <thead> <tr> <th>P214</th> <th>Line Undervoltage/ Phase Fault (E03)</th> </tr> </thead> <tbody> <tr> <td>0</td> <td>Off</td> </tr> <tr> <td>1</td> <td>On</td> </tr> </tbody> </table>	P214	Line Undervoltage/ Phase Fault (E03)	0	Off	1	On		
		P214	Line Undervoltage/ Phase Fault (E03)							
0	Off									
1	On									
<p><b>Table 6.22 - Actuation Line Phase Loss Detection</b></p> <p>The phase loss detector is active when:                      P214 = On and the CFW-09 is enabled.</p> <p>The display indication and the updating of the fault memory happens 3 seconds after the fault has occurred.</p> <p> <b>NOTE!</b>                      The phase loss detection is not available in types up to 28A for 220-230V and 380-480V supply voltage and in types up to 14A for 500-600V supply voltage, independently of the value set in P214.</p>										
<b>P215</b> <sup>(1)</sup> Copy Function	0 to 2 [ 0 ] -	<table border="1"> <thead> <tr> <th>P215</th> <th>Action</th> </tr> </thead> <tbody> <tr> <td>0=Off</td> <td>None</td> </tr> <tr> <td>1= INV → Keypad</td> <td>Transfers the current parameter values and the content of the User 1/2 Memories to the non volatile EEPROM memory of the Keypad (HMI). The current inverter parameters are not changed.</td> </tr> <tr> <td>2= Keypad → INV</td> <td>Transfers the content of the Keypad (HMI) memory to the current inverter parameters and to the User 1/2 Memories.</td> </tr> </tbody> </table>	P215	Action	0=Off	None	1= INV → Keypad	Transfers the current parameter values and the content of the User 1/2 Memories to the non volatile EEPROM memory of the Keypad (HMI). The current inverter parameters are not changed.	2= Keypad → INV	Transfers the content of the Keypad (HMI) memory to the current inverter parameters and to the User 1/2 Memories.
P215	Action									
0=Off	None									
1= INV → Keypad	Transfers the current parameter values and the content of the User 1/2 Memories to the non volatile EEPROM memory of the Keypad (HMI). The current inverter parameters are not changed.									
2= Keypad → INV	Transfers the content of the Keypad (HMI) memory to the current inverter parameters and to the User 1/2 Memories.									
<p><b>Table 6.23 - Action copy function</b></p>										

Parameter	Range [Factory Setting] Unit	Description / Notes
		<p><input checked="" type="checkbox"/> The copy function is used to transfer the content of the parameters from one inverter to another. The inverters must be of the same type (voltage/current and the same software version must be installed).</p> <p> <b>NOTE!</b> If the HMI has parameters saved of a “different version” than installed in the inverter to which it is trying to copy the parameters, the operation will not be executed and the inverter will display the error E10 (Error: not permitted Copy Function). “Different Version” are those that are different in “x” or “y”, supposing that the numbering of Software Versions is described as <b>Vx.yz</b>.</p> <p>Example: version V1.60 → (x=1, y=6 and z=0) stored in the HMI previously</p> <ul style="list-style-type: none"> <li>i. Inverter version: V1.75 → (x'=1, y'=7 and z'=5) P215=2 → E10 [(y=6) ≠ (y'=7)]</li> <li>ii. Inverter version: V1.62 → (x'=1, y'=6 and z'=2) P215=2 → normal copy [(y=6) = (y'=6)]</li> </ul> <p>The procedure is as follows:</p> <ol style="list-style-type: none"> <li>1. Connect the Keypad to the inverter from which the parameters will be copied (Inverter A);</li> <li>2. Set P215=1 (INV ® HMI) to transfer the parameter values from the Inverter A to the Keypad.</li> <li>3. Press the  key. P204 resets automatically to 0 (Off) after the transfer is completed.</li> <li>4. Disconnect the Keypad from the inverter.</li> <li>5. Connect the same Keypad to the inverter to which the parameters will be transferred (Inverter B).</li> <li>6. Set P215=2 (HMI ® INV) to transfer the content of the Keypad memory (containing the Inverter A parameters) to Inverter B.</li> <li>7. Press the  key. When P204 returns to 0, the parameter transfer has been concluded. Now Inverters A and B have the same parameter values.</li> </ol> <p><b>Note:</b></p> <ul style="list-style-type: none"> <li><input checked="" type="checkbox"/> In case Inverters A and B are not of the same model, check the values of P295 (Rated Current) and P296 (Rated Voltage) of Inverter B.</li> <li><input checked="" type="checkbox"/> If the inverters are driving different motors, check the motor related parameters of Inverter B.</li> </ul> <ol style="list-style-type: none"> <li>8. To copy the parameters content of the Inverter A to other inverters, repeat items 5 to 7 of this procedure.</li> </ol>

Parameter	Range [Factory Setting] Unit	Description / Notes
		 <p data-bbox="748 932 1495 959"><b>Figure 6.24</b> -Copying the Parameters from the "Inverter A" to the "Inverter B"</p> <ul style="list-style-type: none"> <li data-bbox="695 993 1546 1052">☑ While the Keypad runs the reading or writing procedures, it cannot be operated.</li> </ul>
<p data-bbox="170 1108 240 1136"><b>P216</b></p> <p data-bbox="170 1142 430 1201">Reference Engineering Unit 2</p> <p data-bbox="170 1236 240 1264"><b>P217</b></p> <p data-bbox="170 1270 430 1329">Reference Engineering Unit 3</p>	<p data-bbox="505 1108 618 1167">32 to 127 [ 112 (p) ]</p> <p data-bbox="558 1178 570 1205">-</p> <p data-bbox="505 1236 618 1295">32 to 127 [ 109 (m) ]</p> <p data-bbox="558 1306 570 1333">-</p>	<ul style="list-style-type: none"> <li data-bbox="695 1108 1546 1167">☑ These parameters are useful only for inverters provided with a keypad with LCD display.</li> <li data-bbox="695 1188 1546 1310">☑ The engineering unit of the speed reference is composed of three characters, which will be displayed on the indication of the Speed Reference (P001) and Motor Speed (P002). P207 defines the left character, P216 the center character and P217 the right character.</li> <li data-bbox="695 1331 1214 1358">☑ For more details, refer to Parameter P207.</li> </ul>
<p data-bbox="170 1440 240 1467"><b>P218</b></p> <p data-bbox="170 1474 430 1533">LCD Display Contrast Adjustment</p>	<p data-bbox="505 1440 618 1499">0 to 150 [ 127 ]</p> <p data-bbox="558 1509 570 1537">-</p>	<ul style="list-style-type: none"> <li data-bbox="695 1440 1546 1499">☑ This parameter is useful only for inverters provided with a keypad with LCD display.</li> <li data-bbox="695 1520 1546 1579">☑ It allows the adjustment of the LCD Display contrast. Increase/decrease the parameter content to obtain the best contrast.</li> </ul>
<p data-bbox="170 1665 267 1692"><b>P220</b> <sup>(1)</sup></p> <p data-bbox="170 1698 430 1753">LOCAL/REMOTE Selection Source</p>	<p data-bbox="505 1665 618 1724">0 to 10 [ 2 ]</p> <p data-bbox="558 1734 570 1761">-</p>	<ul style="list-style-type: none"> <li data-bbox="695 1665 1546 1692">☑ Defines the source of the LOCAL / REMOTE selection command.</li> </ul>

Parameter	Range [Factory Setting] Unit	Description / Notes																								
		<table border="1"> <thead> <tr> <th>P220</th> <th>LOCAL/REMOTE Selection</th> </tr> </thead> <tbody> <tr> <td>0</td> <td>Always LOCAL Mode</td> </tr> <tr> <td>1</td> <td>Always REMOTE mode</td> </tr> <tr> <td>2</td> <td>Key  of the Keypad (HMI) (LOCAL Default)</td> </tr> <tr> <td>3</td> <td>Key  of the Keypad (HMI) (REMOTE Default)</td> </tr> <tr> <td>4</td> <td>Digital inputs DI2 to DI8 (P264 to P270)</td> </tr> <tr> <td>5</td> <td>Serial (Local Default) - SuperDrive or incorporated Modbus</td> </tr> <tr> <td>6</td> <td>Serial (Remote Default) - SuperDrive or incorporated Modbus</td> </tr> <tr> <td>7</td> <td>Fieldbus (Local Default) - Optimal Fieldbus board</td> </tr> <tr> <td>8</td> <td>Fieldbus (Remote Default) - Optimal Fieldbus board</td> </tr> <tr> <td>9</td> <td>PLC (L) - Optimal PLC board</td> </tr> <tr> <td>10</td> <td>PLC (R) - Optimal PLC board</td> </tr> </tbody> </table> <p style="text-align: center;"><b>Table 6.24 - LOCAL/REMOTE Selection</b></p> <p><input checked="" type="checkbox"/> In the factory default setting, the key  of the Keypad (HMI) will select Local or Remote Mode. When powered up, the inverter starts in Local mode.</p>	P220	LOCAL/REMOTE Selection	0	Always LOCAL Mode	1	Always REMOTE mode	2	Key  of the Keypad (HMI) (LOCAL Default)	3	Key  of the Keypad (HMI) (REMOTE Default)	4	Digital inputs DI2 to DI8 (P264 to P270)	5	Serial (Local Default) - SuperDrive or incorporated Modbus	6	Serial (Remote Default) - SuperDrive or incorporated Modbus	7	Fieldbus (Local Default) - Optimal Fieldbus board	8	Fieldbus (Remote Default) - Optimal Fieldbus board	9	PLC (L) - Optimal PLC board	10	PLC (R) - Optimal PLC board
P220	LOCAL/REMOTE Selection																									
0	Always LOCAL Mode																									
1	Always REMOTE mode																									
2	Key  of the Keypad (HMI) (LOCAL Default)																									
3	Key  of the Keypad (HMI) (REMOTE Default)																									
4	Digital inputs DI2 to DI8 (P264 to P270)																									
5	Serial (Local Default) - SuperDrive or incorporated Modbus																									
6	Serial (Remote Default) - SuperDrive or incorporated Modbus																									
7	Fieldbus (Local Default) - Optimal Fieldbus board																									
8	Fieldbus (Remote Default) - Optimal Fieldbus board																									
9	PLC (L) - Optimal PLC board																									
10	PLC (R) - Optimal PLC board																									



**P221** <sup>(1)</sup>  
LOCAL Speed  
Reference Selection

0 to 11  
[ 0 ]  
-



The description AI1' as apposed to AI1 refers to the analogue signal after scaling and/or gain calculations have been applied to it (See figure 6.29).

**P222** <sup>(1)</sup>  
REMOTE Speed  
Reference Selection

0 to 11  
[ 1 ]  
-

P221/P222	LOCAL/REMOTE Speed Reference Selection
0	 and  of the keypad
1	Analog Input AI1' (P234/P235/P236)
2	Analog Input AI2' (P237/P238/P239/P240)
3	Analog Input AI3' (P241/P242/P243/P244)
4	Analog Input AI4' (P245/P246/P247)
5	Sum of the Analog Inputs AI1' + AI2' > 0 (Negative values are zeroed)
6	Sum of the Analog Inputs AI1' + AI2'
7	Electronic Potentiometer (EP)
8	Multispeed (P124 to P131)
9	Serial
10	Fieldbus
11	PLC

**Table 6.25 - LOCAL/REMOTE Speed Reference Selection**

- The reference value set by the  and  keys is contained in parameter P121.
- Details of the Electronic Potentiometer (EP) operation in Figure 6.37.
- When option 7 (EP) is selected, program P265 or P267=5 and P266 or P268=5.
- When option 8 is selected, program P266 and/or P267 and/or P268 to 7.
- When P203=1 (PID), do not use the reference via EP (P221/P222=7).
- When P203=1 (PID), the value programmed in P221/P222 becomes the PID setpoint.







Parameter	Range [Factory Setting] Unit	Description / Notes																										
<b>P223</b> <sup>(1)</sup> <sup>(8)</sup> LOCAL FWD/REV Selection	0 to 11 [ 2 ] -	<table border="1"> <thead> <tr> <th>P223</th> <th>LOCAL FWD/REV Selection</th> </tr> </thead> <tbody> <tr> <td>0</td> <td>Always Forward</td> </tr> <tr> <td>1</td> <td>Always Reverse</td> </tr> <tr> <td>2</td> <td>Key  of the Keypad (Default Forward)</td> </tr> <tr> <td>3</td> <td>Key  of the Keypad (Reverse Default)</td> </tr> <tr> <td>4</td> <td>Digital Input DI2 (P264 = 0)</td> </tr> <tr> <td>5</td> <td>Serial (FWD Default)</td> </tr> <tr> <td>6</td> <td>Reserved Serial (REV Default)</td> </tr> <tr> <td>7</td> <td>Fieldbus (FWD Default)</td> </tr> <tr> <td>8</td> <td>Fieldbus (REV Default)</td> </tr> <tr> <td>9</td> <td>Polarity AI4</td> </tr> <tr> <td>10</td> <td>PLC (FWD)</td> </tr> <tr> <td>11</td> <td>PLC (REV)</td> </tr> </tbody> </table>	P223	LOCAL FWD/REV Selection	0	Always Forward	1	Always Reverse	2	Key  of the Keypad (Default Forward)	3	Key  of the Keypad (Reverse Default)	4	Digital Input DI2 (P264 = 0)	5	Serial (FWD Default)	6	Reserved Serial (REV Default)	7	Fieldbus (FWD Default)	8	Fieldbus (REV Default)	9	Polarity AI4	10	PLC (FWD)	11	PLC (REV)
		P223	LOCAL FWD/REV Selection																									
		0	Always Forward																									
		1	Always Reverse																									
		2	Key  of the Keypad (Default Forward)																									
		3	Key  of the Keypad (Reverse Default)																									
		4	Digital Input DI2 (P264 = 0)																									
		5	Serial (FWD Default)																									
		6	Reserved Serial (REV Default)																									
		7	Fieldbus (FWD Default)																									
		8	Fieldbus (REV Default)																									
		9	Polarity AI4																									
10	PLC (FWD)																											
11	PLC (REV)																											

Table 6.26 - LOCAL FWD/REV Selection









<b>P224</b> <sup>(1)</sup> LOCAL START/STOP Selection	0 to 4 [ 0 ] -	<table border="1"> <thead> <tr> <th>P224</th> <th>LOCAL START/STOP Selection</th> </tr> </thead> <tbody> <tr> <td>0</td> <td> and  of the Keypad.</td> </tr> <tr> <td>1</td> <td>Digital Input (DIx)</td> </tr> <tr> <td>2</td> <td>Serial</td> </tr> <tr> <td>3</td> <td>Fieldbus</td> </tr> <tr> <td>4</td> <td>PLC</td> </tr> </tbody> </table>	P224	LOCAL START/STOP Selection	0	 and  of the Keypad.	1	Digital Input (DIx)	2	Serial	3	Fieldbus	4	PLC
		P224	LOCAL START/STOP Selection											
		0	 and  of the Keypad.											
		1	Digital Input (DIx)											
		2	Serial											
3	Fieldbus													
4	PLC													

Table 6.27 - LOCAL START/STOP Selection

Note: If the Digital Inputs are programmed for Forward Run/Reverse

Run, the  and  keys will remain disabled independently of the value programmed at P224.



<b>P225</b> <sup>(1)</sup> <sup>(8)</sup> LOCAL JOG Selection	0 to 5 [ 1 ] -	<table border="1"> <thead> <tr> <th>P225</th> <th>LOCAL JOG Selection</th> </tr> </thead> <tbody> <tr> <td>0</td> <td>Disable</td> </tr> <tr> <td>1</td> <td>Key  of the Keypad</td> </tr> <tr> <td>2</td> <td>Digital inputs DI3 to DI8 (P265 to P270)</td> </tr> <tr> <td>3</td> <td>Serial</td> </tr> <tr> <td>4</td> <td>Fieldbus</td> </tr> <tr> <td>5</td> <td>PLC</td> </tr> </tbody> </table>	P225	LOCAL JOG Selection	0	Disable	1	Key  of the Keypad	2	Digital inputs DI3 to DI8 (P265 to P270)	3	Serial	4	Fieldbus	5	PLC
		P225	LOCAL JOG Selection													
		0	Disable													
		1	Key  of the Keypad													
		2	Digital inputs DI3 to DI8 (P265 to P270)													
		3	Serial													
4	Fieldbus															
5	PLC															

Table 6.28 - LOCAL JOG Selection

The JOG speed reference is given by parameter P122.







Parameter	Range [Factory Setting] Unit	Description / Notes																										
<b>P226</b> <sup>(1)</sup> <sup>(8)</sup> REMOTE FWD/REV Selection	0 to 11 [ 4 ] -	<table border="1"> <thead> <tr> <th>P226</th> <th>REMOTE FWD/REV Selection</th> </tr> </thead> <tbody> <tr> <td>0</td> <td>Always Forward</td> </tr> <tr> <td>1</td> <td>Always Reverse</td> </tr> <tr> <td>2</td> <td>Key  of the Keypad (Default Forward )</td> </tr> <tr> <td>3</td> <td>Key  of the Keypad (Default Reverse )</td> </tr> <tr> <td>4</td> <td>Digital Input DI2 (P264 = 0)</td> </tr> <tr> <td>5</td> <td>Serial (FWD Default)</td> </tr> <tr> <td>6</td> <td>Serial (REV Default)</td> </tr> <tr> <td>7</td> <td>Fieldbus (FWD Default)</td> </tr> <tr> <td>8</td> <td>Fieldbus (REV Default)</td> </tr> <tr> <td>9</td> <td>Polarity AI4</td> </tr> <tr> <td>10</td> <td>PLC (FWD)</td> </tr> <tr> <td>11</td> <td>PLC (REV)</td> </tr> </tbody> </table>	P226	REMOTE FWD/REV Selection	0	Always Forward	1	Always Reverse	2	Key  of the Keypad (Default Forward )	3	Key  of the Keypad (Default Reverse )	4	Digital Input DI2 (P264 = 0)	5	Serial (FWD Default)	6	Serial (REV Default)	7	Fieldbus (FWD Default)	8	Fieldbus (REV Default)	9	Polarity AI4	10	PLC (FWD)	11	PLC (REV)
		P226	REMOTE FWD/REV Selection																									
		0	Always Forward																									
		1	Always Reverse																									
		2	Key  of the Keypad (Default Forward )																									
		3	Key  of the Keypad (Default Reverse )																									
		4	Digital Input DI2 (P264 = 0)																									
		5	Serial (FWD Default)																									
		6	Serial (REV Default)																									
		7	Fieldbus (FWD Default)																									
		8	Fieldbus (REV Default)																									
		9	Polarity AI4																									
10	PLC (FWD)																											
11	PLC (REV)																											

Table 6.29 - REMOTE FWD/REV Selection









<b>P227</b> <sup>(1)</sup> REMOTE START/ STOP Selection	0 to 4 [ 1 ] -	<table border="1"> <thead> <tr> <th>P227</th> <th>REMOTE START/STOP Selection</th> </tr> </thead> <tbody> <tr> <td>0</td> <td> and  of the Keypad.</td> </tr> <tr> <td>1</td> <td>Digital Input (DIx)</td> </tr> <tr> <td>2</td> <td>Serial</td> </tr> <tr> <td>3</td> <td>Fieldbus</td> </tr> <tr> <td>4</td> <td>PLC</td> </tr> </tbody> </table>	P227	REMOTE START/STOP Selection	0	 and  of the Keypad.	1	Digital Input (DIx)	2	Serial	3	Fieldbus	4	PLC
		P227	REMOTE START/STOP Selection											
		0	 and  of the Keypad.											
		1	Digital Input (DIx)											
		2	Serial											
		3	Fieldbus											
4	PLC													

Table 6.30 - REMOTE START/STOP Selection

Note: If the Digital Inputs are programmed for Forward Run/Reverse

Run, the  and  keys will remain disabled independently of the value programmed at P227.



<b>P228</b> <sup>(1)</sup> <sup>(8)</sup> REMOTE JOG Selection	0 to 5 [ 2 ] -	<table border="1"> <thead> <tr> <th>P228</th> <th>REMOTE JOG Selection</th> </tr> </thead> <tbody> <tr> <td>0</td> <td>Disable</td> </tr> <tr> <td>1</td> <td>Key  of the Keypad</td> </tr> <tr> <td>2</td> <td>Digital inputs DI3 to DI8 (P265 to P270)</td> </tr> <tr> <td>3</td> <td>Serial</td> </tr> <tr> <td>4</td> <td>Fieldbus</td> </tr> <tr> <td>5</td> <td>PLC</td> </tr> </tbody> </table>	P228	REMOTE JOG Selection	0	Disable	1	Key  of the Keypad	2	Digital inputs DI3 to DI8 (P265 to P270)	3	Serial	4	Fieldbus	5	PLC
		P228	REMOTE JOG Selection													
		0	Disable													
		1	Key  of the Keypad													
		2	Digital inputs DI3 to DI8 (P265 to P270)													
		3	Serial													
4	Fieldbus															
5	PLC															

Table 6.31 - REMOTE JOG Selection

The JOG speed reference is given by parameter P122.

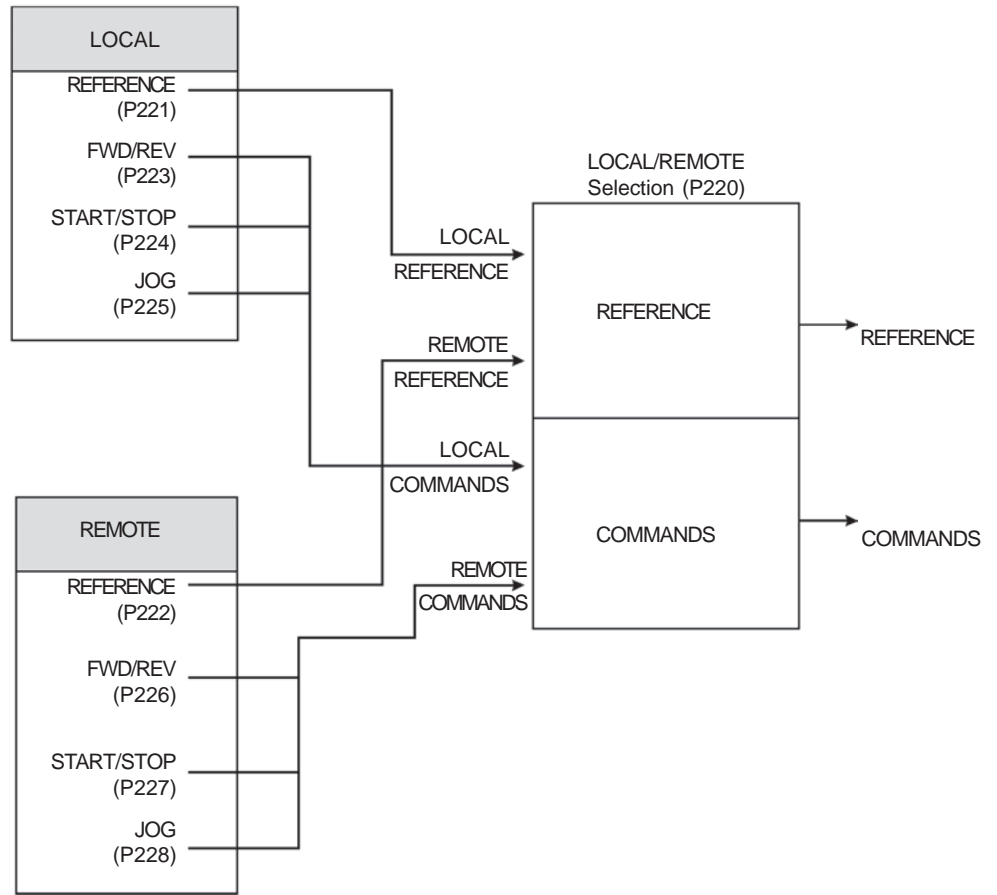
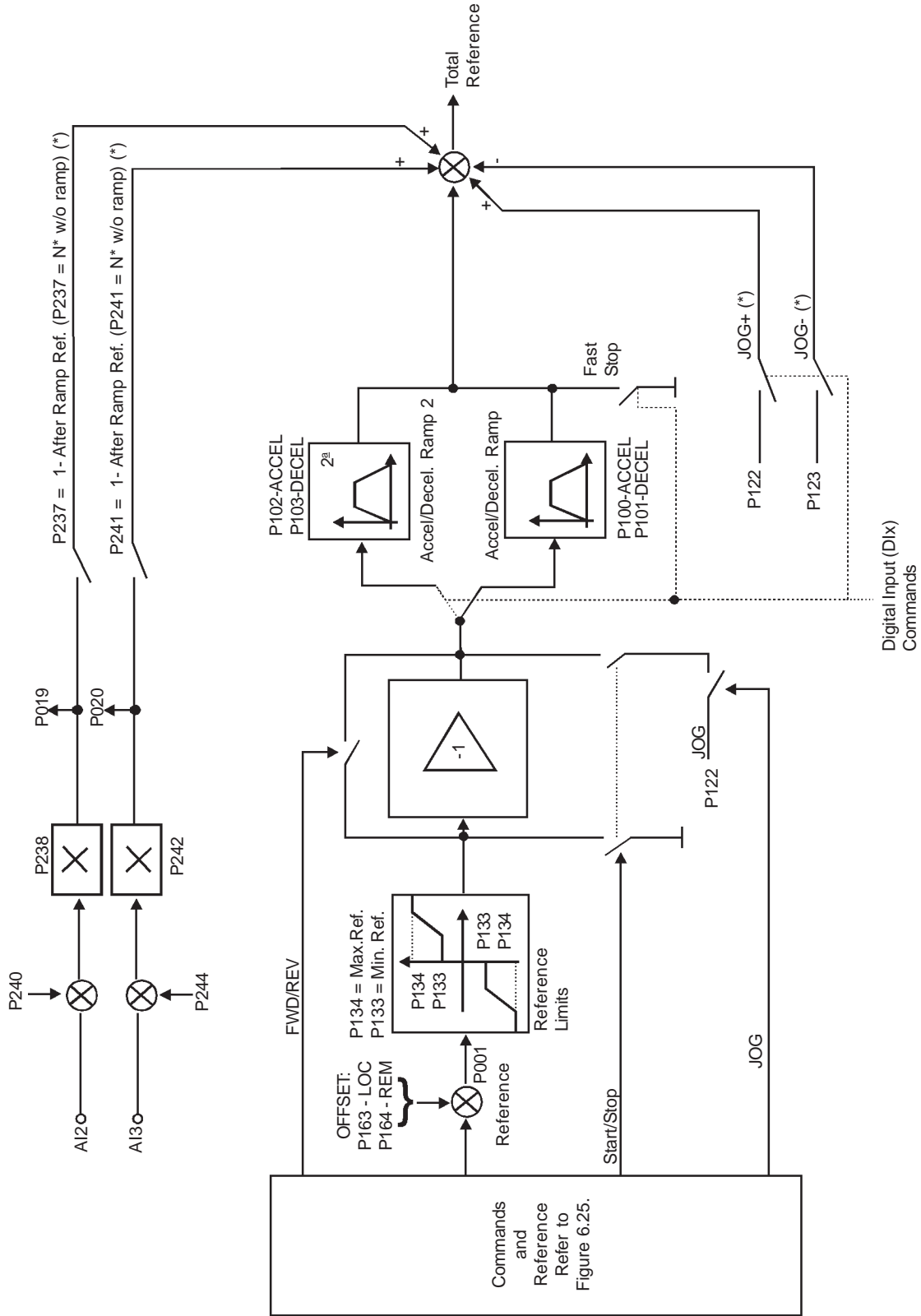

Figure 6.25 - Block diagram of the Local / Remote mode



(\*) Valid only for P202 = 3 and 4.

Figure 6.26 - Block diagram of the Speed Reference

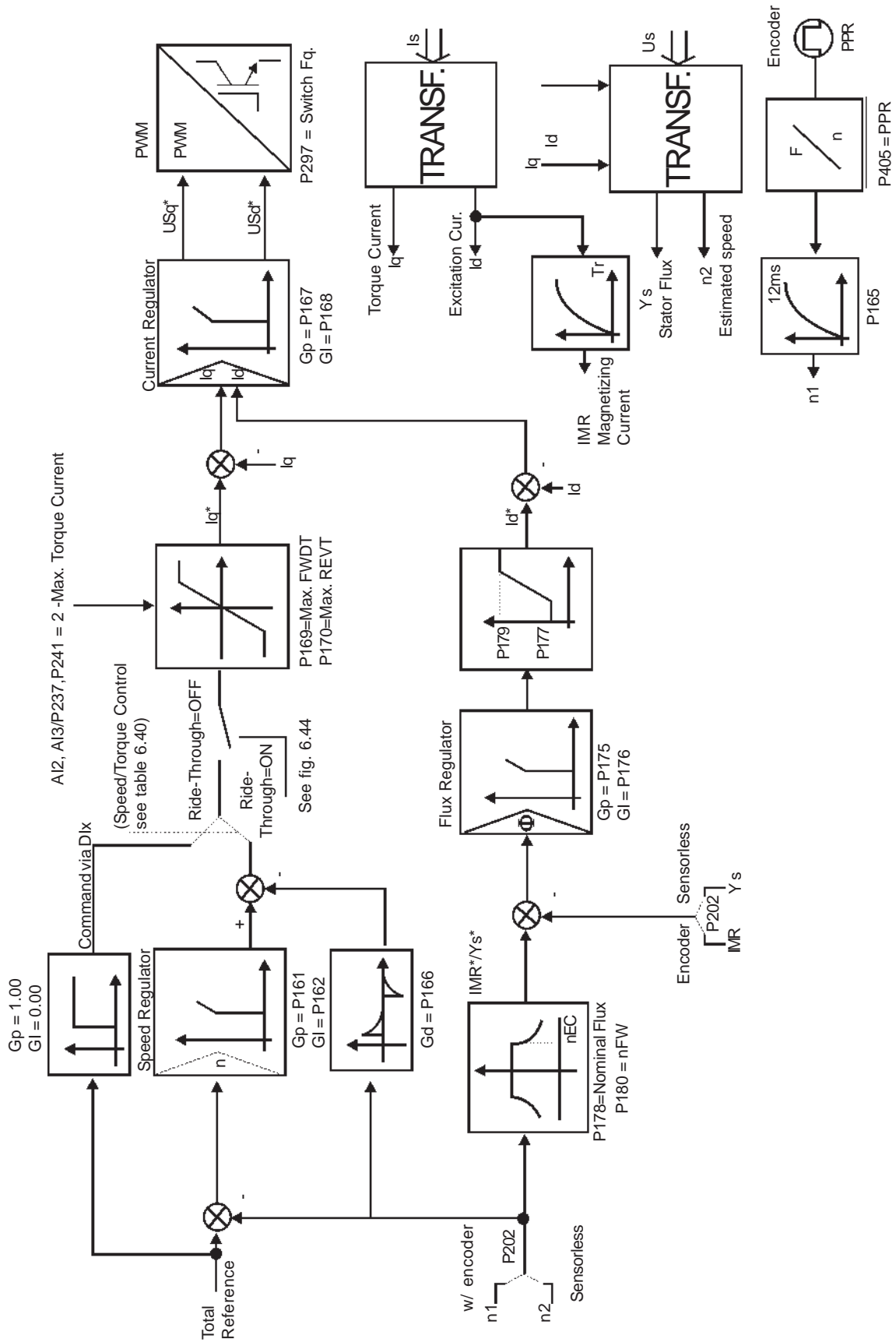

Figure 6.27 a) - Block Diagram of the Vector Control

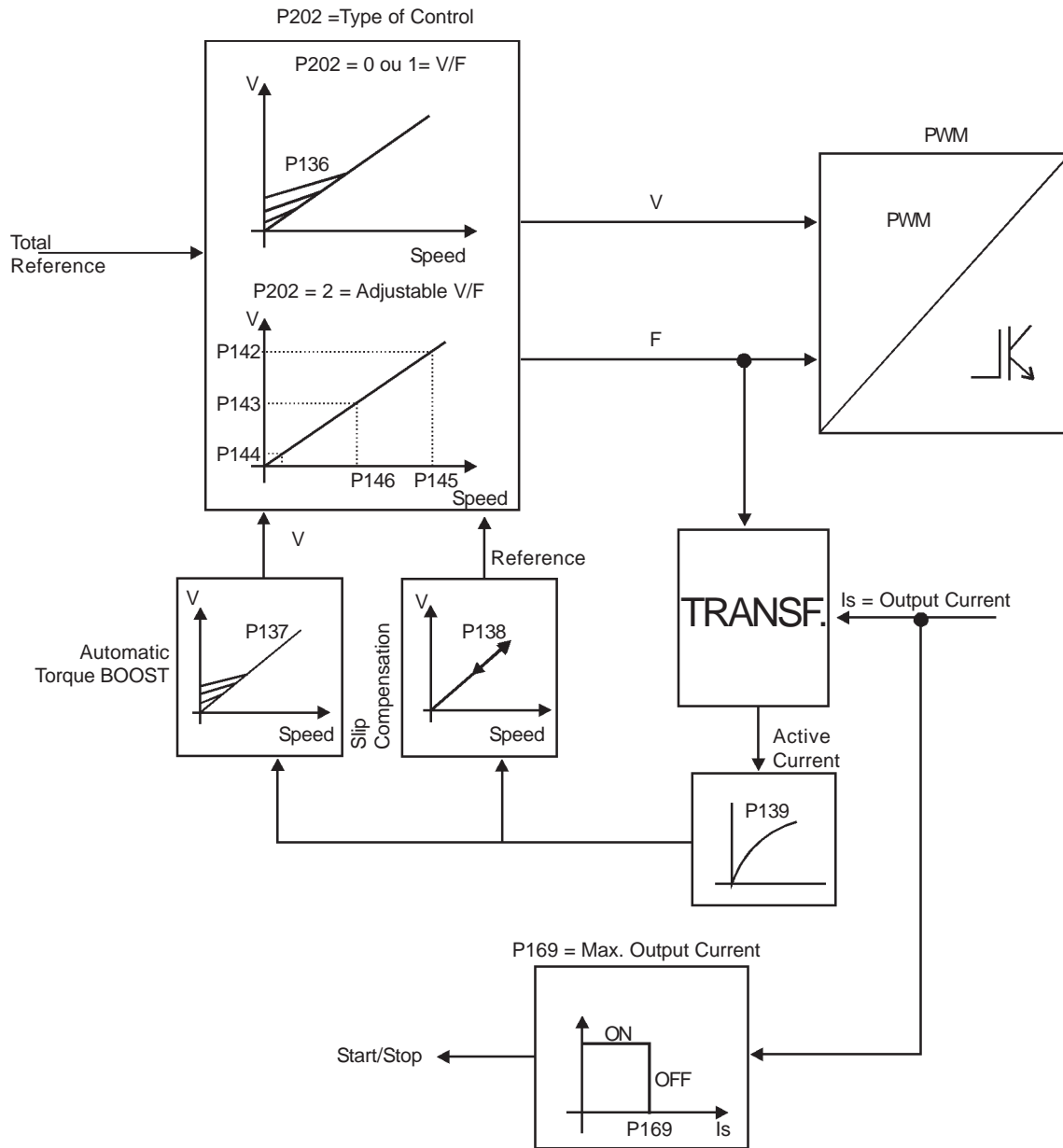

Figure 6.27 b) - Block Diagram of the V/F control (Scalar)

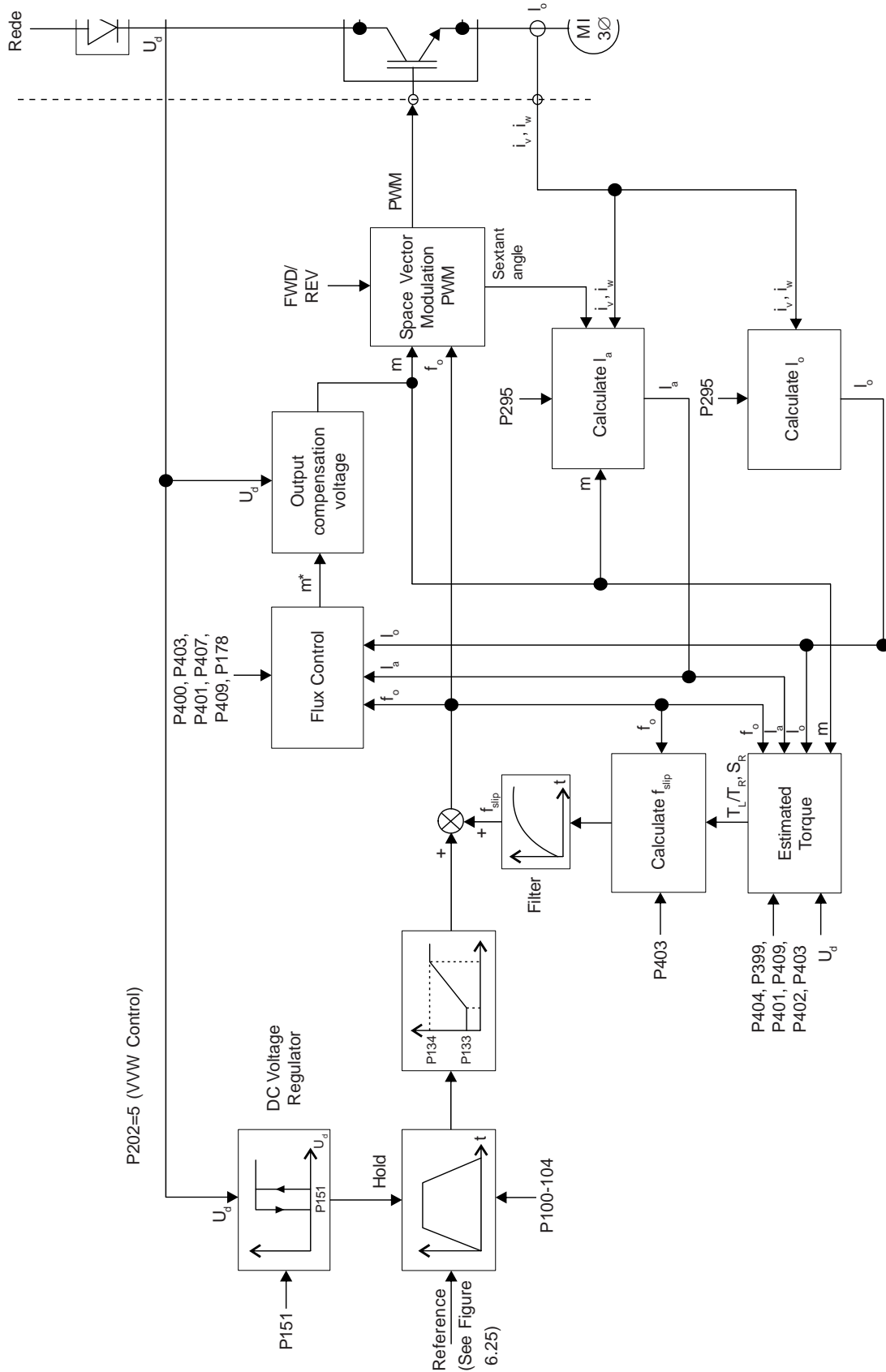



Figure 6.27 c) - Block diagram of the VVW Control

Parameter	Range [Factory Setting] Unit	Description / Notes								
P232 <sup>(1)</sup> Stop Mode Selection	0 to 2 [ 0 ] -	<table border="1"> <thead> <tr> <th>P232</th> <th>Stop Mode</th> </tr> </thead> <tbody> <tr> <td>0</td> <td>Ramp to Stop</td> </tr> <tr> <td>1</td> <td>Coast to Stop</td> </tr> <tr> <td>2</td> <td>Fast Stop</td> </tr> </tbody> </table>	P232	Stop Mode	0	Ramp to Stop	1	Coast to Stop	2	Fast Stop
P232	Stop Mode									
0	Ramp to Stop									
1	Coast to Stop									
2	Fast Stop									

Table 6.32 - Stop Mode Selection

- ☑ Parameter P232 is valid only for the following commands:
  - 1) The key  of the keypad;
  - 2) Start/Stop function with 2-wire control (through DI1=1)
  - 3) Start/Stop function with 3-wire control (refer to parameters from P265 to P270 for a complete description about the function 14).
- ☑ In the V/F mode the option 2 (Fast Stop) is not available.

 **NOTE!**

When the “Coast to Stop” option is selected, only start the motor if it is completely stopped.

- | Parameter                          | Range<br>[Factory Setting]<br>Unit | Description / Notes  |
|------------------------------------|------------------------------------|--|
| P233<br>Analog Inputs<br>Dead Zone | 0,1<br>[ 0 ]<br>-                  | <ul style="list-style-type: none"> <li>☑ This parameter is active only for the analog inputs (Alx) programmed as speed reference.</li> <li>☑ When set to 1 enables the Dead Zone for the Analog Inputs.</li> <li>☑ If P233 = 0 (Off) the “zero” signal at the Analog Inputs (0V/0mA/ 4mA or 10V/20mA) is directly related to the minimum speed programmed at P133. Refer to Figure 6.28 a).</li> <li>☑ If P233 = 1 (On) the Analog Inputs have a “dead zone”, and the speed reference remains at its minimum value (defined by P133) until the input signal reaches a level proportional to the minimum speed. Refer to Figure 6.28 b).</li> </ul> |

a) Inactive Dead Zone P233=0

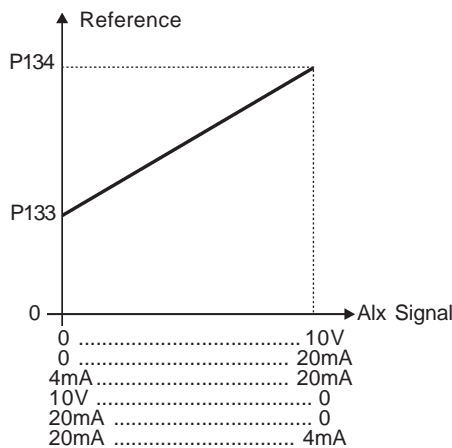

Parameter	Range [Factory Setting] Unit	Description / Notes
-----------	------------------------------------	---------------------

b) Active Dead Zone P233=1

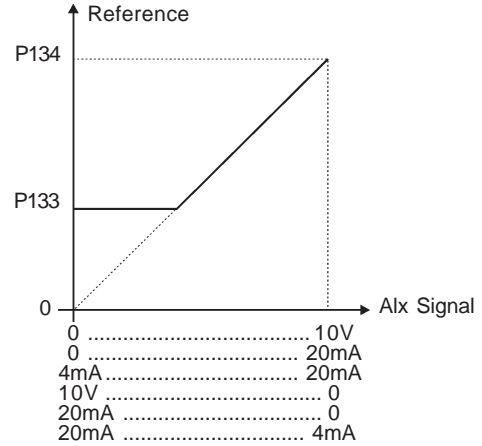

Figure 6.28 a) b) - Actuation of the Analog Inputs

- ☑ When the Analog Input AI4 is programmed for -10V to +10V (P246 = 4), the curves shown in Figure 6.27 are still valid, with the difference that with AI4 negative the direction of rotation is reversed.

<b>P234</b> Analog Input AI1 Gain	0.000 to 9.999 [ 1.000 ] 0.001
--------------------------------------	--------------------------------------

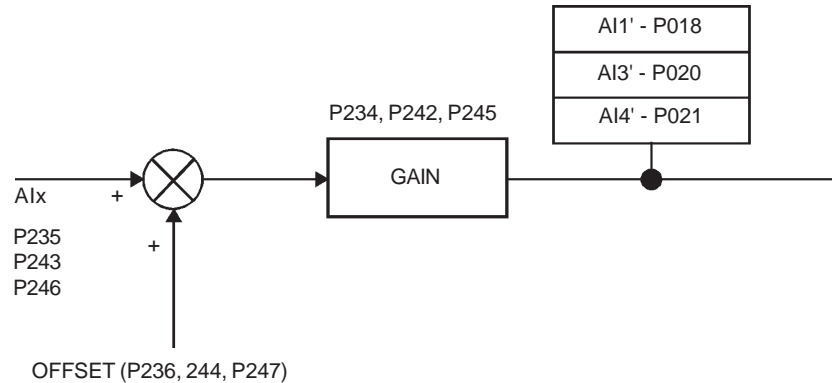

Figure 6.29 - Block diagram of the Analog Input AI1, AI3, AI4

- ☑ The internal values AI1', AI3', and AI4' are the result of the following equation:

$$AIx' = (AIx + \frac{OFFSET \times 10 \text{ V}}{100}) \times \text{Gain}$$

For example : AI1 = 5V, Offset = -70% and Gain = 1.00:

$$AI1' = (5 + \frac{(-70) \times 10 \text{ V}}{100}) \times 1 = -2 \text{ V}$$

AI1' = -2V, means that the motor will run in reverse with a reference equal to 2V.

Parameter	Range [Factory Setting] Unit	Description / Notes															
<b>P235</b> <sup>(1)</sup> Analog Input AI1 Signal	0 to 3 [ 0 ] -	<table border="1"> <thead> <tr> <th>P235</th> <th>Input AI1 Signal</th> <th>Switch S1.2</th> </tr> </thead> <tbody> <tr> <td>0</td> <td>(0 to 10)V / (0 to 20) mA</td> <td>OFF/ON</td> </tr> <tr> <td>1</td> <td>(4 to 20) mA</td> <td>ON</td> </tr> <tr> <td>2</td> <td>(10 to 0)V / (20 to 0) mA</td> <td>OFF/ON</td> </tr> <tr> <td>3</td> <td>(20 to 4) mA</td> <td>ON</td> </tr> </tbody> </table> <p style="text-align: center;"><b>Table 6.33 - AI1 signal selection</b></p> <ul style="list-style-type: none"> <li><input checked="" type="checkbox"/> When a current signal is used at the Analog Input AI1, set the S1.2 switch on the control board to "ON".</li> <li><input checked="" type="checkbox"/> Options 2 and 3 provide an inverse reference with which is possible to have maximum speed with minimum reference.</li> </ul>	P235	Input AI1 Signal	Switch S1.2	0	(0 to 10)V / (0 to 20) mA	OFF/ON	1	(4 to 20) mA	ON	2	(10 to 0)V / (20 to 0) mA	OFF/ON	3	(20 to 4) mA	ON
		P235	Input AI1 Signal	Switch S1.2													
0	(0 to 10)V / (0 to 20) mA	OFF/ON															
1	(4 to 20) mA	ON															
2	(10 to 0)V / (20 to 0) mA	OFF/ON															
3	(20 to 4) mA	ON															
<b>P236</b> Analog Input AI1 Offset	-100 to +100 [ 0.0 ] 0.1%	<ul style="list-style-type: none"> <li><input checked="" type="checkbox"/> Refer to P234.</li> </ul>															
<b>P237</b> <sup>(1)(8)</sup> Analog Input AI2 Function	0 to 3 [ 0 ] -	<table border="1"> <thead> <tr> <th>P237</th> <th>Input AI2 Function</th> </tr> </thead> <tbody> <tr> <td>0</td> <td>P221/P222</td> </tr> <tr> <td>1</td> <td>After Ramp Reference</td> </tr> <tr> <td>2</td> <td>Maximum Torque Current</td> </tr> <tr> <td>3</td> <td>PID Process Variable</td> </tr> <tr> <td>4</td> <td>Maximum Torque Current (AI2+AI1)</td> </tr> </tbody> </table> <p style="text-align: center;"><b>Table 6.34 - AI2 function</b></p> <ul style="list-style-type: none"> <li><input checked="" type="checkbox"/> When the option 0 (P221/P222) is selected, AI2 may supply the speed reference (if set to do so at P221/P222), which is subject to the speed limits (P133, P134) and the acceleration/deceleration ramps (P100 to P103). Refer to Figure 6.25.</li> <li><input checked="" type="checkbox"/> The option 1 (After Ramp Reference, valid only for P202=3 and 4) is generally used as an additional reference signal, for instance, in applications with a dancer. Refer to Figure 6.25. It bypasses the accel/ decel ramp.</li> <li><input checked="" type="checkbox"/> The option 2 (Maximum Torque Current) permits controlling the torque current limit P169, P170 through the analog input AI2. In this case P169, P170 will be Read only parameters. See figure 6.26a). For this type of control, check if P160 should be equal to one or zero.</li> <li><input checked="" type="checkbox"/> When AI2 is set to maximum (P019 = 100%), the torque limit will be also maximum - P169/P170 = 180%.</li> <li><input checked="" type="checkbox"/> The option 3 (PID Process Variable) defines the input AI2 as feedback signal of the PID regulator (for instance: pressure, temperature sensor, etc.), if P524=0.</li> <li><input checked="" type="checkbox"/> When AI2 is set to its maximum value (P019=100%), the PID process variable will be on its maximum value (100%).</li> </ul>	P237	Input AI2 Function	0	P221/P222	1	After Ramp Reference	2	Maximum Torque Current	3	PID Process Variable	4	Maximum Torque Current (AI2+AI1)			
		P237	Input AI2 Function														
0	P221/P222																
1	After Ramp Reference																
2	Maximum Torque Current																
3	PID Process Variable																
4	Maximum Torque Current (AI2+AI1)																

Parameter	Range [Factory Setting] Unit	Description / Notes
		<p><b>Option 4 – Maximum Torque Current (AI2+AI1):</b></p> <ul style="list-style-type: none"> <li>☑ When parameters P237=2 and P241=0, the torque current limit (P169 and P170) is given by the signal at the Analog Input AI2.</li> <li>When parameters P237=4 and P241=0, the torque current limit (P169 and P170) is given by the sum of the signals at Analog Inputs AI1 and AI2.</li> <li>☑ When parameters P237=2 and P241=2, the torque current limit (P169 and P170) is given by the signal at the Analog Input AI2.</li> <li>☑ When parameters P237=4 and P241=2, the torque current limit (P169 and P170) is given by the sum of the signals at Analog Inputs AI1 and AI2.</li> <li>☑ When parameters P237=4 and P241=4, the torque current limit (P169 and P170) is given by the sum of the signals at Analog Inputs AI1 and AI2.</li> </ul> <p><b>Note:</b> The range of the sum between AI1 and AI2 may vary from 0 to 180%. If the sum result is negative, then the value will be set to zero.</p>

<p><b>P238</b> Analog Input AI2 Gain</p>	<p>0.000 to 9.999 [ 1.000 ] 0.001</p>
--	---

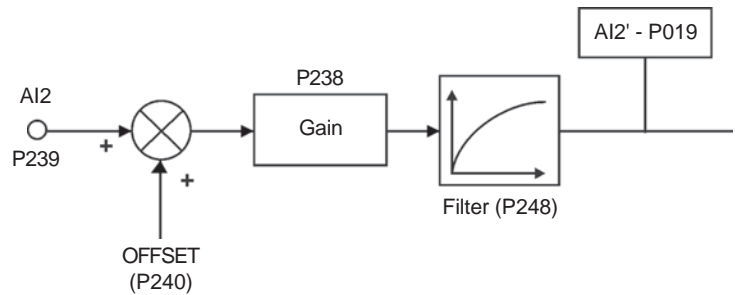

Figure 6.29 - Block diagram of the Analog Input AI2

- ☑ The internal value of AI2' is the result of the following equation:  

$$AI2' = (AI2 + \frac{OFFSET}{100} \times 10V) \times Gain$$

For example: AI2 = 5V, OFFSET = -70% and Gain = 1.00:

$$AI2' = (5 + \frac{-70}{100} \times 10V) \times 1 = -2V$$

AI2' = -2V, means that the motor runs in reverse direction reference equal to 2V

<p><b>P239</b> <sup>(1)</sup> Analog Input AI2 Signal</p>	<p>0 to 3 [ 0 ] -</p>
---	-------------------------------

P239	Input AI2 Signal	Switch S1.1
0	(0 to 10)V / (0 to 20) mA	OFF/ON
1	(4 to 20) mA	ON
2	(10 to 0)V / (20 to 0) mA	OFF/ON
3	(20 to 4) mA	ON

Table 6.35 - AI2 signal selection

Parameter	Range [Factory Setting] Unit	Description / Notes												
		<ul style="list-style-type: none"> <li><input checked="" type="checkbox"/> When a current signal is used at the Analog Input AI2, set the switch S1.1 on the control board to "ON".</li> <li><input checked="" type="checkbox"/> Options 2 and 3 provide an inverse reference with which is possible to have maximum speed with minimum reference.</li> </ul>												
<b>P240</b> Analog Input AI2 Offset	-100 to +100 [ 0.0 ] 0.1%	<input checked="" type="checkbox"/> Refer to P234.												
<b>P241</b> <sup>(1)</sup> Analog Input AI3 Function (Isolated analog input on the optional board EBB. Refer to Chapter 8)	0 to 3 [ 0 ] -	<table border="1" style="margin-left: auto; margin-right: auto;"> <thead> <tr> <th>P241</th> <th>Input AI3 Function</th> </tr> </thead> <tbody> <tr> <td>0</td> <td>P221/P222</td> </tr> <tr> <td>1</td> <td>After Ramp Reference</td> </tr> <tr> <td>2</td> <td>Maximum Torque Current</td> </tr> <tr> <td>3</td> <td>PID Process Variable</td> </tr> <tr> <td>4</td> <td>Maximum Torque Current (AI3+AI2)</td> </tr> </tbody> </table> <p style="text-align: center;"><b>Table 6.36 - AI3 function</b></p> <ul style="list-style-type: none"> <li><input checked="" type="checkbox"/> When the option 0 (P221/P222) is selected, AI3 may supply the speed reference (if set to do so at P221/P222), which is subject to the speed limits (P133, P134) and the acceleration/deceleration ramps (P100 to P103). Refer to Figure 6.25.</li> <li><input checked="" type="checkbox"/> The option 1 (After Ramp Reference, valid only for P202=3 and 4) is generally used as an additional reference signal, for instance, in applications with a dancer. Refer to Figure 6.25. It bypasses the accel/ decel ramp.</li> <li><input checked="" type="checkbox"/> The option 2 (Maximum Torque Current) permits controlling the torque current limit P169, P170 through the analog input AI3. In this case P169, P170 will be Read only parameters. See figure 6.26 a). For this type of control, check if P160 should be equal to one or zero.</li> <li><input checked="" type="checkbox"/> When AI3 is set to maximum (P020 = 100%), the torque limit will be also maximum - P169/P170 = 180%.</li> <li><input checked="" type="checkbox"/> The option 3 (Process Variable) defines the input AI3 as feedback signal of the PID Regulator (for instance: pressure, temperature sensor, etc.), if P524=1.</li> <li><input checked="" type="checkbox"/> When AI3 is set to its maximum value (P020=100%), the PID process variable will be on its maximum value (100%).</li> </ul> <p><b>Option 4 - Maximum Torque Current (AI3+AI2):</b></p> <ul style="list-style-type: none"> <li><input checked="" type="checkbox"/> When parameters P237=0 and P241=2, the torque current limit (P169 and P170) is given by the signal at the Analog Input AI3.</li> <li><input checked="" type="checkbox"/> When parameters P237=0 and P241=4, the torque current limit (P169 and P170) is given by the sum of the signals at Analog Inputs AI2 and AI3.</li> </ul>	P241	Input AI3 Function	0	P221/P222	1	After Ramp Reference	2	Maximum Torque Current	3	PID Process Variable	4	Maximum Torque Current (AI3+AI2)
P241	Input AI3 Function													
0	P221/P222													
1	After Ramp Reference													
2	Maximum Torque Current													
3	PID Process Variable													
4	Maximum Torque Current (AI3+AI2)													

Parameter	Range [Factory Setting] Unit	Description / Notes																		
		<ul style="list-style-type: none"> <li><input checked="" type="checkbox"/> When parameters P237=2 and P241=2, the torque current limit (P169 and P170) is given by the signal at the Analog Input AI2.</li> <li><input checked="" type="checkbox"/> When parameters P237=2 and P241=4, the torque current limit (P169 and P170) is given by the sum of the signals at Analog Inputs AI2 and AI3.</li> <li><input checked="" type="checkbox"/> When parameters P237=4 and P241=4, the torque current limit (P169 and P170) is given by the sum of the signals at Analog Inputs AI1 and AI2.</li> </ul> <p><b>Note:</b> The range of the sum between AI2 and AI3 may vary from 0 to 180%. If the sum result is negative, then the value will be set to zero.</p>																		
<b>P242</b> Analog Input AI3 Gain	0.000 to 9.999 [ 1.000 ] 0.001	<input checked="" type="checkbox"/> Refer to P234.																		
<b>P243</b> <sup>(1)</sup> Analog Input AI3 Signal	0 to 3 [ 0 ] -	<table border="1" style="width: 100%; border-collapse: collapse; text-align: center;"> <thead> <tr> <th>P243</th> <th>Input AI3 Signal</th> <th>Switch S 4.1 (EBB)</th> </tr> </thead> <tbody> <tr> <td>0</td> <td>(0 to 10)V / (0 to 20) mA</td> <td>Off/On</td> </tr> <tr> <td>1</td> <td>(4 to 20) mA</td> <td>On</td> </tr> <tr> <td>2</td> <td>(10 to 0)V / (20 to 0) mA</td> <td>Off/On</td> </tr> <tr> <td>3</td> <td>(20 to 4) mA</td> <td>On</td> </tr> </tbody> </table> <p style="text-align: center;"><i>Table 6.37 - AI3 signal selection</i></p> <ul style="list-style-type: none"> <li><input checked="" type="checkbox"/> When a current signal is used at the Analog Input AI3, set the S4.1 switch on the EBB board to "ON".</li> <li><input checked="" type="checkbox"/> Options 2 and 3 provide an inverse reference with which is possible to have maximum speed with minimum reference.</li> </ul>	P243	Input AI3 Signal	Switch S 4.1 (EBB)	0	(0 to 10)V / (0 to 20) mA	Off/On	1	(4 to 20) mA	On	2	(10 to 0)V / (20 to 0) mA	Off/On	3	(20 to 4) mA	On			
P243	Input AI3 Signal	Switch S 4.1 (EBB)																		
0	(0 to 10)V / (0 to 20) mA	Off/On																		
1	(4 to 20) mA	On																		
2	(10 to 0)V / (20 to 0) mA	Off/On																		
3	(20 to 4) mA	On																		
<b>P244</b> Analog Input AI3 Offset	-100 to +100 [ 0.0 ] 0.1%	<input checked="" type="checkbox"/> Refer to P234.																		
<b>P245</b> Analog Input AI4 Gain (14 bit Analog Input of the optional board EBA. Refer to Chapter 8)	0.000 to 9.999 [ 1.000 ] 0.001	<input checked="" type="checkbox"/> Refer to P234.																		
<b>P246</b> <sup>(1)</sup> Analog Input AI4 Signal	0 to 4 [ 0 ] -	<table border="1" style="width: 100%; border-collapse: collapse; text-align: center;"> <thead> <tr> <th>P243</th> <th>Input AI4 Signal</th> <th>Switch S 2.1 (EBA)</th> </tr> </thead> <tbody> <tr> <td>0</td> <td>(0 to 10)V / (0 to 20)mA</td> <td>OFF/ON</td> </tr> <tr> <td>1</td> <td>(4 to 20) mA</td> <td>ON</td> </tr> <tr> <td>2</td> <td>(10 to 0)V / (20 to 0)mA</td> <td>OFF/ON</td> </tr> <tr> <td>3</td> <td>(20 to 4)mA</td> <td>ON</td> </tr> <tr> <td>4</td> <td>(-10 to +10)V</td> <td>OFF</td> </tr> </tbody> </table> <p style="text-align: center;"><i>Table 6.38 - AI4 signal selection</i></p>	P243	Input AI4 Signal	Switch S 2.1 (EBA)	0	(0 to 10)V / (0 to 20)mA	OFF/ON	1	(4 to 20) mA	ON	2	(10 to 0)V / (20 to 0)mA	OFF/ON	3	(20 to 4)mA	ON	4	(-10 to +10)V	OFF
P243	Input AI4 Signal	Switch S 2.1 (EBA)																		
0	(0 to 10)V / (0 to 20)mA	OFF/ON																		
1	(4 to 20) mA	ON																		
2	(10 to 0)V / (20 to 0)mA	OFF/ON																		
3	(20 to 4)mA	ON																		
4	(-10 to +10)V	OFF																		

Parameter	Range [Factory Setting] Unit	Description / Notes
		<ul style="list-style-type: none"> <li><input checked="" type="checkbox"/> When a current signal is used at the Analog Input AI4, set the switch S2.1 on the EBA board to "ON".</li> <li><input checked="" type="checkbox"/> Options 2 and 3 provide an inverse reference with which is possible to have maximum speed with minimum reference.</li> </ul>
<b>P247</b> Analog Input AI4 Offset	-100 to +100 [ 0.0 ] 0.1%	<input checked="" type="checkbox"/> Refer to P234.
<b>P248</b> Filter Input AI2	0.0 to 16.0 [ 0.0 ] 0.1s	<input checked="" type="checkbox"/> It sets the time constant of the RC Filter of the Input AI2 (see Figure 6.29)
<b>P251</b> Analog Output AO1 Function	0 to 13 [ 2 ] -	<ul style="list-style-type: none"> <li><input checked="" type="checkbox"/> Check possible options on Table 6.39.</li> <li><input checked="" type="checkbox"/> With factory default values (P251 = 2 and P252 = 1.000) AO1 = 10V when the motor speed is equal to the maximum speed defined at P134.</li> <li><input checked="" type="checkbox"/> The AO1 output can be physically located on the control board CC9 (as a 0V to 10V output) or on the option board EBB (AO1', as a (0 to 20)mA/ (4 to 20)mA output). Refer to Chapter 8.</li> </ul>
<b>P252</b> Analog Output AO1 Gain	0.000 to 9.999 [ 1.000 ] 0.001	<input checked="" type="checkbox"/> Adjusts the gain of the AO1 analog output. For P252=1.000 the AO1 output value is set according to the description after figure 6.31.
<b>P253</b> Analog Output AO2 Function	0 to 13 [ 5 ] -	<ul style="list-style-type: none"> <li><input checked="" type="checkbox"/> Check possible options on Table 6.39.</li> <li><input checked="" type="checkbox"/> With factory default values (P253 = 5 and P254 = 1.000) AO2 = 10V when the output current is equal to 1.5 x P295.</li> <li><input checked="" type="checkbox"/> The AO2 output can be physically located on the control board CC9 (as a 0V to 10V output) or on the option board EBB [(AO2' , as a (0 to 20)mA/ (4 to 20)mA output)]. Refer to Chapter 8.</li> </ul>
<b>P254</b> Analog Output AO2 Gain	0.000 to 9.999 [ 1.000 ] 0.001	<input checked="" type="checkbox"/> Adjusts the gain of the AO2 analog output. For P254=1.000 the AO2 output value is set according to the description after figure 6.31.
<b>P255</b> Analog Output AO3 Function (Located on the Optional I/O Expansion Board EBA)	0 to 62 [ 2 ] -	<ul style="list-style-type: none"> <li><input checked="" type="checkbox"/> Check possible options on Table 6.39.</li> <li><input checked="" type="checkbox"/> With factory default values (P255 = 2 and P256 = 1.000) AO3 = 10V when the motor speed is equal to maximum speed defined at P134.</li> <li><input checked="" type="checkbox"/> For more information about the Analog Output AO3, refer to Chapter 8.</li> </ul>

Parameter	Range [Factory Setting] Unit	Description / Notes																																																																																
<b>P256</b> Analog Output AO3 Gain	0.000 to 9.999 [ 1.000 ] 0.001	<ul style="list-style-type: none"> <li><input checked="" type="checkbox"/> Adjusts the gain of the AO3 analog output for P256=1.000 the AO3 output value is set according to the description after figure 6.31.</li> </ul>																																																																																
<b>P257</b> Analog Output AO4 Function (Located on the Optional I/O Expansion Board EBA)	0 to 62 [ 5 ] -	<ul style="list-style-type: none"> <li><input checked="" type="checkbox"/> Check possible options on Table 6.39.</li> <li><input checked="" type="checkbox"/> For factory default values (P257 = 5 and P258 = 1.000) AO4 = 10V when the output current is equal to 1.5 x P295.</li> <li><input checked="" type="checkbox"/> For more information about the AO4 output, refer to Chapter 8.</li> </ul> <table border="1" style="margin: 10px auto; border-collapse: collapse; text-align: center;"> <thead> <tr> <th>Functions</th> <th>P251 (AO1)</th> <th>P253 (AO2)</th> <th>P255 (AO3)</th> <th>P257 (AO4)</th> </tr> </thead> <tbody> <tr><td>Speed Reference</td><td>0</td><td>0</td><td>0</td><td>0</td></tr> <tr><td>Total Reference</td><td>1</td><td>1</td><td>1</td><td>1</td></tr> <tr><td>Real Speed</td><td>2</td><td>2</td><td>2</td><td>2</td></tr> <tr><td>Torque Reference [P202 = 3 or 4 (Vector)]</td><td>3</td><td>3</td><td>3</td><td>3</td></tr> <tr><td>Torque Current [P202 = 3 or 4 (Vector)]</td><td>4</td><td>4</td><td>4</td><td>4</td></tr> <tr><td>Output Current (with filter 0.3s)</td><td>5</td><td>5</td><td>5</td><td>5</td></tr> <tr><td>PID Process Variable</td><td>6</td><td>6</td><td>6</td><td>6</td></tr> <tr><td>Active Current [P202 = 0,1, 2 or 5] (with filter 0.1s)</td><td>7</td><td>7</td><td>7</td><td>7</td></tr> <tr><td>Power (kW) (with filter 0.5s)</td><td>8</td><td>8</td><td>8</td><td>8</td></tr> <tr><td>PID Setpoint</td><td>9</td><td>9</td><td>9</td><td>9</td></tr> <tr><td>Torque Positive [P202=3 or 4 (vector)]</td><td>10</td><td>10</td><td>10</td><td>10</td></tr> <tr><td>Motor Torque</td><td>11</td><td>11</td><td>11</td><td>11</td></tr> <tr><td>PLC</td><td>12</td><td>12</td><td>12</td><td>12</td></tr> <tr><td>Dead zone for speed indication</td><td>13</td><td>13</td><td>-</td><td>-</td></tr> <tr><td>WEG Use</td><td>-</td><td>-</td><td>14 to 62</td><td>14 to 62</td></tr> </tbody> </table>	Functions	P251 (AO1)	P253 (AO2)	P255 (AO3)	P257 (AO4)	Speed Reference	0	0	0	0	Total Reference	1	1	1	1	Real Speed	2	2	2	2	Torque Reference [P202 = 3 or 4 (Vector)]	3	3	3	3	Torque Current [P202 = 3 or 4 (Vector)]	4	4	4	4	Output Current (with filter 0.3s)	5	5	5	5	PID Process Variable	6	6	6	6	Active Current [P202 = 0,1, 2 or 5] (with filter 0.1s)	7	7	7	7	Power (kW) (with filter 0.5s)	8	8	8	8	PID Setpoint	9	9	9	9	Torque Positive [P202=3 or 4 (vector)]	10	10	10	10	Motor Torque	11	11	11	11	PLC	12	12	12	12	Dead zone for speed indication	13	13	-	-	WEG Use	-	-	14 to 62	14 to 62
Functions	P251 (AO1)	P253 (AO2)	P255 (AO3)	P257 (AO4)																																																																														
Speed Reference	0	0	0	0																																																																														
Total Reference	1	1	1	1																																																																														
Real Speed	2	2	2	2																																																																														
Torque Reference [P202 = 3 or 4 (Vector)]	3	3	3	3																																																																														
Torque Current [P202 = 3 or 4 (Vector)]	4	4	4	4																																																																														
Output Current (with filter 0.3s)	5	5	5	5																																																																														
PID Process Variable	6	6	6	6																																																																														
Active Current [P202 = 0,1, 2 or 5] (with filter 0.1s)	7	7	7	7																																																																														
Power (kW) (with filter 0.5s)	8	8	8	8																																																																														
PID Setpoint	9	9	9	9																																																																														
Torque Positive [P202=3 or 4 (vector)]	10	10	10	10																																																																														
Motor Torque	11	11	11	11																																																																														
PLC	12	12	12	12																																																																														
Dead zone for speed indication	13	13	-	-																																																																														
WEG Use	-	-	14 to 62	14 to 62																																																																														
<b>P258</b> Analog Output AO4 Gain	0.000 to 9.999 [ 1.000 ] 0.001	<ul style="list-style-type: none"> <li><input checked="" type="checkbox"/> Adjusts the gain of the AO4 analog output for P258=1.000 the AO4 output value is set according to the description after figure 6.31.</li> </ul>																																																																																

Table 6.39 - Functions of the Analog Outputs

Parameter	Range [Factory Setting] Unit	Description / Notes
<b>P259</b> Dead zone for speed indication	0 a P134 [ 1000 ] 1 rpm	<div data-bbox="727 331 1406 968" data-label="Diagram"> </div> <p data-bbox="768 989 1268 1014"><i>Figure 6.31 - Block diagram of the Analog Outputs</i></p> <p data-bbox="631 1043 1138 1073"><b>Scale of the Analog Outputs indications:</b></p> <ul style="list-style-type: none"> <li data-bbox="605 1094 1448 1150">☑ Full scale = 10V: for outputs AO1 and AO2 located on the control board CC9 and AO3 and AO4 located on the optional board EBA;</li> <li data-bbox="605 1171 1448 1228">☑ Full scale = 20mA for the outputs AO11 and AO21 located on the optional board EBB.</li> <li data-bbox="605 1249 1130 1278">☑ Speed Reference (P001): Full scale = P134</li> <li data-bbox="605 1299 1029 1329">☑ Total Reference: Full scale = P134</li> <li data-bbox="605 1350 1081 1379">☑ Motor Speed (P002): Full scale = P134</li> <li data-bbox="605 1400 1117 1430">☑ Torque Reference: Full scale = 2.0 x P295</li> <li data-bbox="605 1451 1084 1480">☑ Torque Current: Full scale = 2.0 x P295</li> <li data-bbox="605 1501 1084 1530">☑ Output Current: Full scale = 1.5 x P295</li> <li data-bbox="605 1551 1154 1581">☑ PID Process Variable: full scale = 1.0 x P528</li> <li data-bbox="605 1602 1078 1631">☑ Active Current: Full scale = 1.5 x P295</li> <li data-bbox="605 1652 1109 1682">☑ Power: Full scale = 1.5 x <math>\sqrt{3}</math>.P295 x P296</li> <li data-bbox="605 1703 1052 1732">☑ PID Setpoint: full scale = 1.0 x P528</li> <li data-bbox="605 1753 1057 1782">☑ Motor Torque: full scale = 2.0 x P295</li> <li data-bbox="605 1803 1216 1833">☑ Dead Zone for Speed Indication: Full scale = P134</li> </ul> <p data-bbox="605 1822 1448 1980">☑ While the speed indication in P002 is below of the value set at P259 (P002&lt;P259), the value of the analog output (P251 and/or P253=13) will remain at 0V or 0mA/4mA. When the speed value is above the value set at P259, then the analog output will vary between its minimum and maximum value.</p>

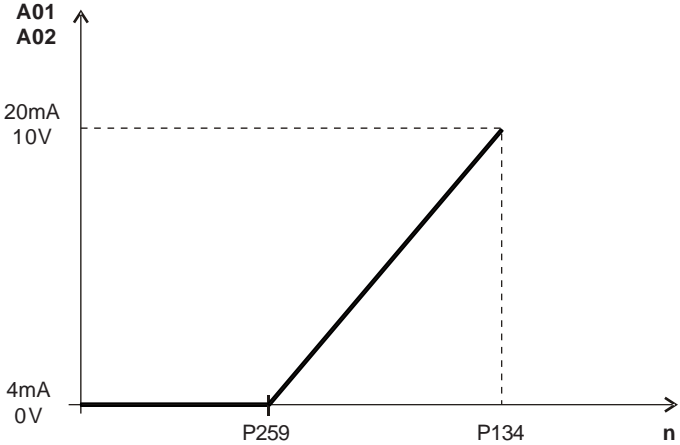
Parameter	Range [Factory Setting] Unit	Description / Notes
		 <p data-bbox="922 806 1370 831"><i>Figure 6.32 - Dead zone for speed indication</i></p> <p data-bbox="699 890 899 926"><b>NOTES!</b></p> <ul data-bbox="776 947 1539 1163" style="list-style-type: none"> <li>☑ For current analog output (0 to 20mA or 4 to 20mA) it is necessary to use the EBB expansion board.</li> <li>☑ A voltage analog output (0 to 10V) is available at the CC9 control board.</li> <li>☑ The analog outputs AO3 and AO4 do not have this function, i.e., set P255 and/or P257 = 13 will program no function.</li> </ul>
<b>P263</b> <sup>(1)</sup> Digital Input DI1 Function	0 to 3 [ 1 (Start/Stop) ] -	<ul style="list-style-type: none"> <li>☑ Check possible options on Table 6.40 and details about each function's operation on Figure 6.37.</li> <li>☑ The status of the digital inputs can be monitored at Parameter P012.</li> </ul>
<b>P264</b> <sup>(1)</sup> Digital Input DI2 Function	0 to 8 [ 0 (FWD/REV) ] -	
<b>P265</b> <sup>(1)(8)</sup> Digital Input DI3 Function	0 to 22 [ 0 (Not Used) ] -	
<b>P266</b> <sup>(1)</sup> Digital Input DI4 Function	0 to 22 [ 0 (Not Used) ] -	
<b>P267</b> <sup>(1)</sup> Digital Input DI5 Function	0 to 22 [ 3 (JOG) ]	

Parameter	Range [Factory Setting] Unit	Description / Notes																																																																																																																																																																																																																																																																														
<b>P268</b> <sup>(1)</sup> Digital Input DI6 Function	0 to 22 [ 6 (Ramp 2) ]	<table border="1"> <thead> <tr> <th>Parameter (Input) Function</th> <th>P263 (DI1)</th> <th>P264 (DI2)</th> <th>P265 (DI3)</th> <th>P266 (DI4)</th> <th>P267 (DI5)</th> <th>P268 (DI6)</th> <th>P269 (DI7)</th> <th>P270 (DI8)</th> </tr> </thead> <tbody> <tr> <td>Not Used</td> <td>0</td> <td>-</td> <td>0, 7 and 16</td> <td>0 and 16</td> <td>0 and 16</td> <td>0 and 16</td> <td>0, 5, 7 and 16</td> <td>0, 5 and 7</td> </tr> <tr> <td>Start/Stop</td> <td>1</td> <td>-</td> <td>-</td> <td>-</td> <td>-</td> <td>-</td> <td>-</td> <td>-</td> </tr> <tr> <td>General Enable</td> <td>2</td> <td>-</td> <td>2</td> <td>2</td> <td>2</td> <td>2</td> <td>2</td> <td>2</td> </tr> <tr> <td>Fast Stop</td> <td>3</td> <td>-</td> <td>-</td> <td>-</td> <td>8</td> <td>8</td> <td>8</td> <td>8</td> </tr> <tr> <td>FWD/REV</td> <td>-</td> <td>0</td> <td>-</td> <td>-</td> <td>-</td> <td>-</td> <td>-</td> <td>-</td> </tr> <tr> <td>Local/Remote</td> <td>-</td> <td>1</td> <td>1</td> <td>1</td> <td>1</td> <td>1</td> <td>1</td> <td>1</td> </tr> <tr> <td>JOG</td> <td>-</td> <td>-</td> <td>3</td> <td>3</td> <td>3</td> <td>3</td> <td>3</td> <td>3</td> </tr> <tr> <td>No external Fault</td> <td>-</td> <td>-</td> <td>4</td> <td>4</td> <td>4</td> <td>4</td> <td>4</td> <td>4</td> </tr> <tr> <td>Increase EP</td> <td>-</td> <td>-</td> <td>5</td> <td>-</td> <td>5</td> <td>-</td> <td>-</td> <td>-</td> </tr> <tr> <td>Decrease EP</td> <td>-</td> <td>-</td> <td>-</td> <td>5</td> <td>-</td> <td>5</td> <td>-</td> <td>-</td> </tr> <tr> <td>Ramp 2</td> <td>-</td> <td>-</td> <td>6</td> <td>6</td> <td>6</td> <td>6</td> <td>6</td> <td>6</td> </tr> <tr> <td>FWD Run</td> <td>-</td> <td>-</td> <td>8</td> <td>-</td> <td>-</td> <td>-</td> <td>-</td> <td>-</td> </tr> <tr> <td>REV Run</td> <td>-</td> <td>8</td> <td>-</td> <td>8</td> <td>-</td> <td>-</td> <td>-</td> <td>-</td> </tr> <tr> <td>Speed/Torque</td> <td>-</td> <td>-</td> <td>9</td> <td>9</td> <td>9</td> <td>9</td> <td>9</td> <td>9</td> </tr> <tr> <td>JOG+</td> <td>-</td> <td>-</td> <td>10</td> <td>10</td> <td>10</td> <td>10</td> <td>10</td> <td>10</td> </tr> <tr> <td>JOG-</td> <td>-</td> <td>-</td> <td>11</td> <td>11</td> <td>11</td> <td>11</td> <td>11</td> <td>11</td> </tr> <tr> <td>Reset</td> <td>-</td> <td>-</td> <td>12</td> <td>12</td> <td>12</td> <td>12</td> <td>12</td> <td>12</td> </tr> <tr> <td>Fieldbus</td> <td>-</td> <td>-</td> <td>13</td> <td>13</td> <td>13</td> <td>13</td> <td>13</td> <td>13</td> </tr> <tr> <td>Start (3 wire)</td> <td>-</td> <td>-</td> <td>14</td> <td>-</td> <td>14</td> <td>-</td> <td>14</td> <td>-</td> </tr> <tr> <td>Stop (3 wire)</td> <td>-</td> <td>-</td> <td>-</td> <td>14</td> <td>-</td> <td>14</td> <td>-</td> <td>14</td> </tr> <tr> <td>Multispeed (MSx)</td> <td>-</td> <td>-</td> <td>-</td> <td>7</td> <td>7</td> <td>7</td> <td>-</td> <td>-</td> </tr> <tr> <td>Manual/Automatic</td> <td>-</td> <td>-</td> <td>15</td> <td>15</td> <td>15</td> <td>15</td> <td>15</td> <td>15</td> </tr> <tr> <td>Motor Thermistor</td> <td>-</td> <td>-</td> <td>-</td> <td>-</td> <td>-</td> <td>-</td> <td>-</td> <td>16</td> </tr> <tr> <td>Disables Flying Start</td> <td>-</td> <td>-</td> <td>17</td> <td>17</td> <td>17</td> <td>17</td> <td>17</td> <td>17</td> </tr> <tr> <td>DC Link Voltage Regulator</td> <td>-</td> <td>-</td> <td>18</td> <td>18</td> <td>18</td> <td>18</td> <td>18</td> <td>18</td> </tr> <tr> <td>Parameter Setting Disable</td> <td>-</td> <td>-</td> <td>19</td> <td>19</td> <td>19</td> <td>19</td> <td>19</td> <td>19</td> </tr> <tr> <td>Load User</td> <td>-</td> <td>-</td> <td>20</td> <td>20</td> <td>20</td> <td>20</td> <td>20</td> <td>-</td> </tr> <tr> <td>Timer RL2</td> <td>-</td> <td>-</td> <td>21</td> <td>21</td> <td>21</td> <td>21</td> <td>21</td> <td>21</td> </tr> <tr> <td>Timer RL3</td> <td>-</td> <td>-</td> <td>22</td> <td>22</td> <td>22</td> <td>22</td> <td>22</td> <td>22</td> </tr> </tbody> </table>	Parameter (Input) Function	P263 (DI1)	P264 (DI2)	P265 (DI3)	P266 (DI4)	P267 (DI5)	P268 (DI6)	P269 (DI7)	P270 (DI8)	Not Used	0	-	0, 7 and 16	0 and 16	0 and 16	0 and 16	0, 5, 7 and 16	0, 5 and 7	Start/Stop	1	-	-	-	-	-	-	-	General Enable	2	-	2	2	2	2	2	2	Fast Stop	3	-	-	-	8	8	8	8	FWD/REV	-	0	-	-	-	-	-	-	Local/Remote	-	1	1	1	1	1	1	1	JOG	-	-	3	3	3	3	3	3	No external Fault	-	-	4	4	4	4	4	4	Increase EP	-	-	5	-	5	-	-	-	Decrease EP	-	-	-	5	-	5	-	-	Ramp 2	-	-	6	6	6	6	6	6	FWD Run	-	-	8	-	-	-	-	-	REV Run	-	8	-	8	-	-	-	-	Speed/Torque	-	-	9	9	9	9	9	9	JOG+	-	-	10	10	10	10	10	10	JOG-	-	-	11	11	11	11	11	11	Reset	-	-	12	12	12	12	12	12	Fieldbus	-	-	13	13	13	13	13	13	Start (3 wire)	-	-	14	-	14	-	14	-	Stop (3 wire)	-	-	-	14	-	14	-	14	Multispeed (MSx)	-	-	-	7	7	7	-	-	Manual/Automatic	-	-	15	15	15	15	15	15	Motor Thermistor	-	-	-	-	-	-	-	16	Disables Flying Start	-	-	17	17	17	17	17	17	DC Link Voltage Regulator	-	-	18	18	18	18	18	18	Parameter Setting Disable	-	-	19	19	19	19	19	19	Load User	-	-	20	20	20	20	20	-	Timer RL2	-	-	21	21	21	21	21	21	Timer RL3	-	-	22	22	22	22	22	22
	Parameter (Input) Function		P263 (DI1)	P264 (DI2)	P265 (DI3)	P266 (DI4)	P267 (DI5)	P268 (DI6)	P269 (DI7)	P270 (DI8)																																																																																																																																																																																																																																																																						
Not Used	0	-	0, 7 and 16	0 and 16	0 and 16	0 and 16	0, 5, 7 and 16	0, 5 and 7																																																																																																																																																																																																																																																																								
Start/Stop	1	-	-	-	-	-	-	-																																																																																																																																																																																																																																																																								
General Enable	2	-	2	2	2	2	2	2																																																																																																																																																																																																																																																																								
Fast Stop	3	-	-	-	8	8	8	8																																																																																																																																																																																																																																																																								
FWD/REV	-	0	-	-	-	-	-	-																																																																																																																																																																																																																																																																								
Local/Remote	-	1	1	1	1	1	1	1																																																																																																																																																																																																																																																																								
JOG	-	-	3	3	3	3	3	3																																																																																																																																																																																																																																																																								
No external Fault	-	-	4	4	4	4	4	4																																																																																																																																																																																																																																																																								
Increase EP	-	-	5	-	5	-	-	-																																																																																																																																																																																																																																																																								
Decrease EP	-	-	-	5	-	5	-	-																																																																																																																																																																																																																																																																								
Ramp 2	-	-	6	6	6	6	6	6																																																																																																																																																																																																																																																																								
FWD Run	-	-	8	-	-	-	-	-																																																																																																																																																																																																																																																																								
REV Run	-	8	-	8	-	-	-	-																																																																																																																																																																																																																																																																								
Speed/Torque	-	-	9	9	9	9	9	9																																																																																																																																																																																																																																																																								
JOG+	-	-	10	10	10	10	10	10																																																																																																																																																																																																																																																																								
JOG-	-	-	11	11	11	11	11	11																																																																																																																																																																																																																																																																								
Reset	-	-	12	12	12	12	12	12																																																																																																																																																																																																																																																																								
Fieldbus	-	-	13	13	13	13	13	13																																																																																																																																																																																																																																																																								
Start (3 wire)	-	-	14	-	14	-	14	-																																																																																																																																																																																																																																																																								
Stop (3 wire)	-	-	-	14	-	14	-	14																																																																																																																																																																																																																																																																								
Multispeed (MSx)	-	-	-	7	7	7	-	-																																																																																																																																																																																																																																																																								
Manual/Automatic	-	-	15	15	15	15	15	15																																																																																																																																																																																																																																																																								
Motor Thermistor	-	-	-	-	-	-	-	16																																																																																																																																																																																																																																																																								
Disables Flying Start	-	-	17	17	17	17	17	17																																																																																																																																																																																																																																																																								
DC Link Voltage Regulator	-	-	18	18	18	18	18	18																																																																																																																																																																																																																																																																								
Parameter Setting Disable	-	-	19	19	19	19	19	19																																																																																																																																																																																																																																																																								
Load User	-	-	20	20	20	20	20	-																																																																																																																																																																																																																																																																								
Timer RL2	-	-	21	21	21	21	21	21																																																																																																																																																																																																																																																																								
Timer RL3	-	-	22	22	22	22	22	22																																																																																																																																																																																																																																																																								
<b>P269</b> <sup>(1)</sup> Digital Input DI7 Function (Located on the optional board EBA or EBB)	0 to 22 [ 0 (Not Used) ]																																																																																																																																																																																																																																																																															
	-																																																																																																																																																																																																																																																																															
<b>P270</b> <sup>(1)</sup> Digital Input DI8 Function (Located on the optional board EBA or EBB)	0 to 22 [ 0 (Not Used) ]																																																																																																																																																																																																																																																																															
	-																																																																																																																																																																																																																																																																															

Table 6.40 - Functions of the Digital Inputs

☑ Notes about the Digital Inputs Functions:

- **Start/Stop** - To ensure the right actuation, this function needs programming P224 and/or P227 = 1.
- **Increase EP** (Electronic Potentiometer) is active when DI3 or DI5 = +24V. Beyond parameters P265 and P267 = 5, it is also necessary setting P221 and/or P222 to 7.
- **Decrease EP** (Electronic Potentiometer) is active when DI4 or DI6 = 0V. Beyond parameters P266 and P268 = 5, it is also necessary setting P221 and/or P222 to 7.
- **Local/Remote** = 0V/24V at the digital input, respectively.
- **Speed/Torque** is valid for P202 = 3 and 4 (Vector Control Sensorless and Vector Control with encoder).

Parameter	Range [Factory Setting] Unit	Description / Notes
		<ul style="list-style-type: none"> <li>- <b>Speed</b> = DIx Open (0V), <b>Torque</b> = DIx Closed (+24V).</li> </ul> <p><b>When Torque</b> is selected the speed regulators gains P161 and P162 are not used and changed to: Gp (Proportional Gain) = 1.00 and Gi (Integral Gain) = 0.00. Thus the Total Reference becomes the input of the Torque Regulator. Refer to Figure 6.26.</p> <p><b>When Speed</b> is selected, the speed regulator gains are defined again by P161 and P162. In applications with torque control, proceed as described at P160.</p> <ul style="list-style-type: none"> <li>- The Option <b>DC Link Voltage Regulator</b> must be used, when P150=2. See description of parameter P150.</li> <li>- DI8 is designed to be used as <b>Motor Termistor</b> (PTC) input in the option boards EBA/EBB:</li> </ul>

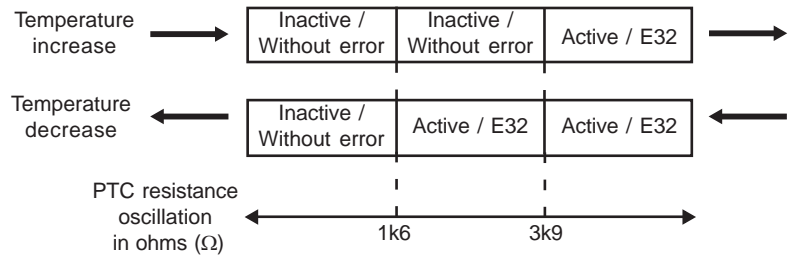
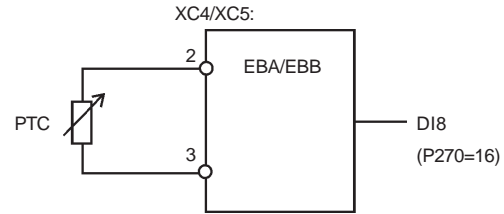

Figure 6.33 - DI8 used as PTC input

- **If DI8 should be used as normal digital input** - Program the parameter P270 to the required function and connect a resistor between 270W and 1600W in series with the input 4, as indicated below:

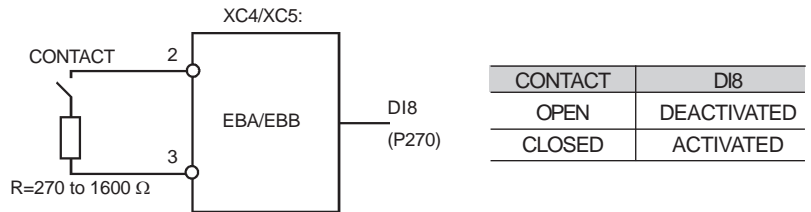

Figure 6.34 - DI8 used as normal DI

Parameter	Range [Factory Setting] Unit	Description / Notes
		<ul style="list-style-type: none"> <li>- The functions <b>JOG+</b> and <b>JOG-</b> – are valid only for <math>P202 \geq 3</math>.</li> <li>- The option <b>Fieldbus</b> sets the DI as a remote input for the fieldbus system and in order to become effective it must be read as any other DI of the inverter.</li> </ul> <p><b>Disable Flying Starts:</b> Put +24V at the digital input to disable Flying Start.</p> <ul style="list-style-type: none"> <li>- The function <b>Loads user via Dlx</b>, permits the memory selection of the user 1 or 2, process similar to <math>P204=7</math> and <math>P204=8</math>, but the user is loaded from the transition of a Dlx programmed for this function.</li> </ul> <p>The memory of user 1 is loaded, when the Dlx status changes from low level to high level (transition from 0V to 24V) and <math>P265</math> to <math>P269=20</math>, provided the current parameter contents of the inverter have been transferred previously to the parameter memory 1 (<math>P204=10</math>).</p> <p>The memory of user 2 is loaded, when the Dlx status changes from high level to low level (transition from 24V to 0V) and <math>P265</math> to <math>P269=20</math>, provided the current parameter contents of the inverter have been transferred previously to the parameter memory 2 (<math>P204=11</math>).</p>

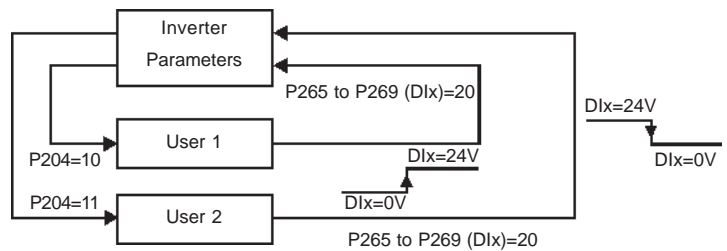

Figure 6.35 - Details about the operation of the function load user via Dlx

**NOTE!**

- ☑ Ensure that when using this function, the parameter sets (User Memory 1 and 2) are totally compatible with the used installations (motors, ON/OFF commands, etc.).
  - ☑ User memory cannot be loaded when motor is enabled.
  - ☑ When two different motor parameter sets are saved into the User Memory 1 and 2, respectively, set for each user the correct values at the Parameters P156, P157 and P158.
- ☑ When the function **'Parameter Setting Disable'** is programmed and the Dlx input is +24V, the parameters cannot be changed, independent of the values that have been set at P000 and P200. When the Dlx input is set to 0V, the parameter changing will be conditioned to the values set at P000 and P200.

Parameter	Range [Factory Setting] Unit	Description / Notes
		<p><input checked="" type="checkbox"/> <b>'Timer RL2 and RL3'</b> function enables and disables the Relays 2 and 3 (RL2 and RL3).</p> <p>When the timing function of the relays 2 and 3 is programmed at any Dlx, and when the transition is effected from 0V to 24V, the relay will be enabled according to the time set at P283 (RL2) or P285 (RL3). When the transition from 24V to 0V occurs, the programmed relay will be disabled according to the time set at P284(RL2) or P286(RL3).</p> <p>After the Dlx transition, to enable or disable the programmed relay, it is required that the Dlx remains in on/off status during the time set at parameters P283/P285 and P284/P286. Otherwise the relay will be reset. See figure 6.36.</p> <p>Note: For this function, program P279 and/or P280 = 28 (Timer).</p>

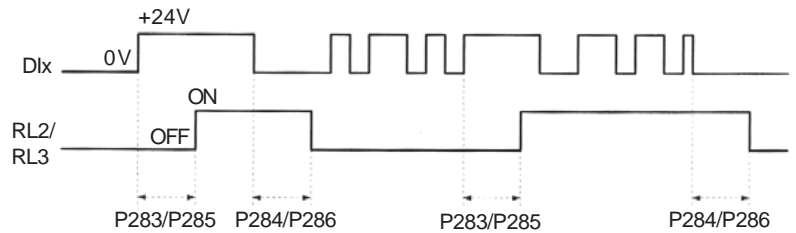
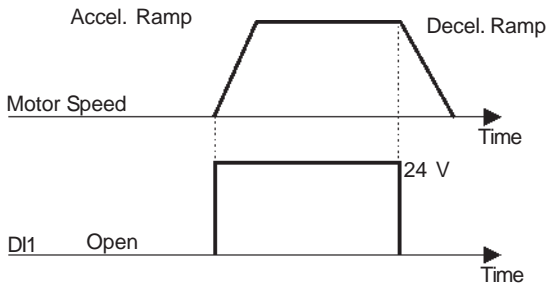

Figure 6.36 - Operation of the function of the Timers RL2 and RL3

- Multispeed:** The selection of P266 and/or P267 and/or P268 = 7 requires that P221 and/or P222=8. See parameters P124 to P131.

**a) START/STOP**



Note: All digital inputs set to general enable must be on in order that the inverter operate as shown above.

**b) GENERAL ENABLE**

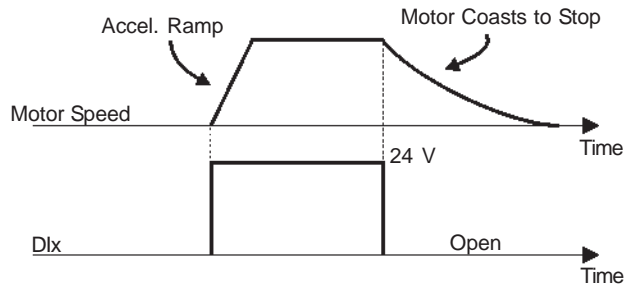

Note: All digital inputs set to start/stop must be on in order that the inverter operate as shown above.

**c) NO EXTERNAL FAULT**

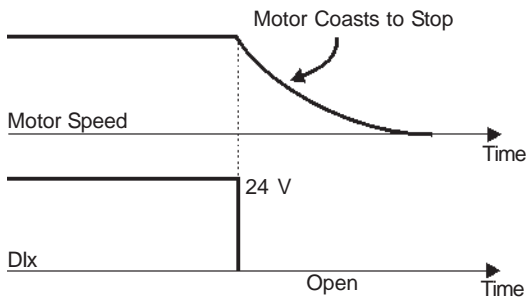

**d) FWD/REV**

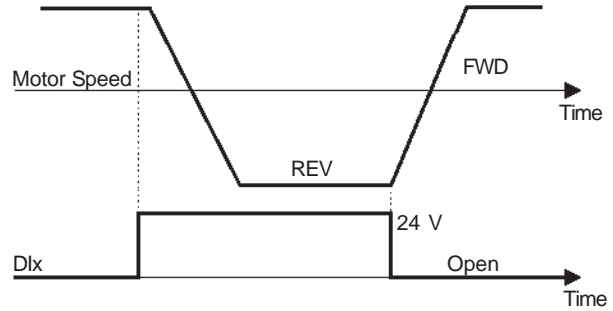

**e) RAMP 2**

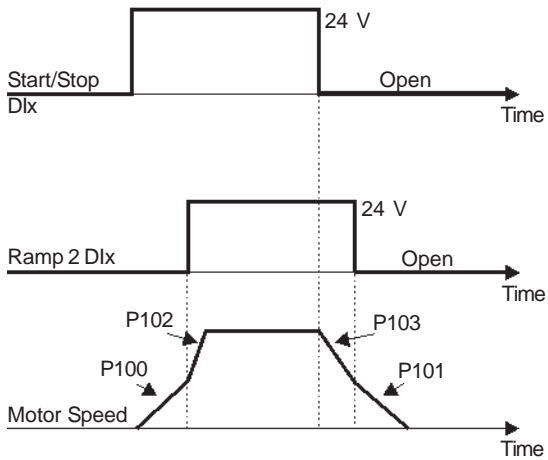

**f) FAST STOP**

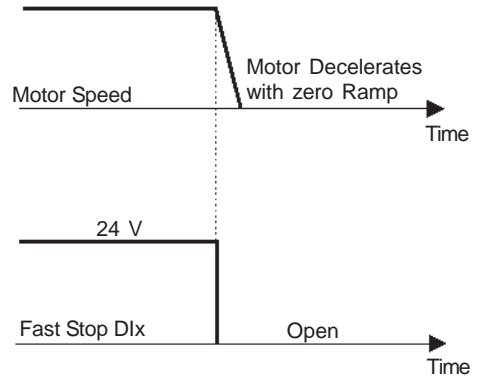

**g) LOAD USER VIA DIx**

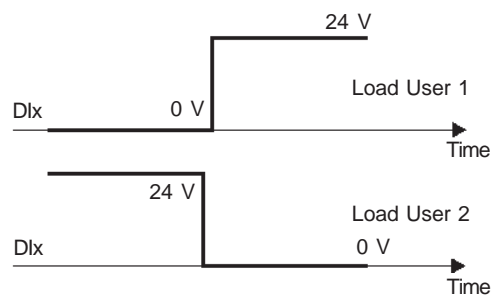

**h) JOG**

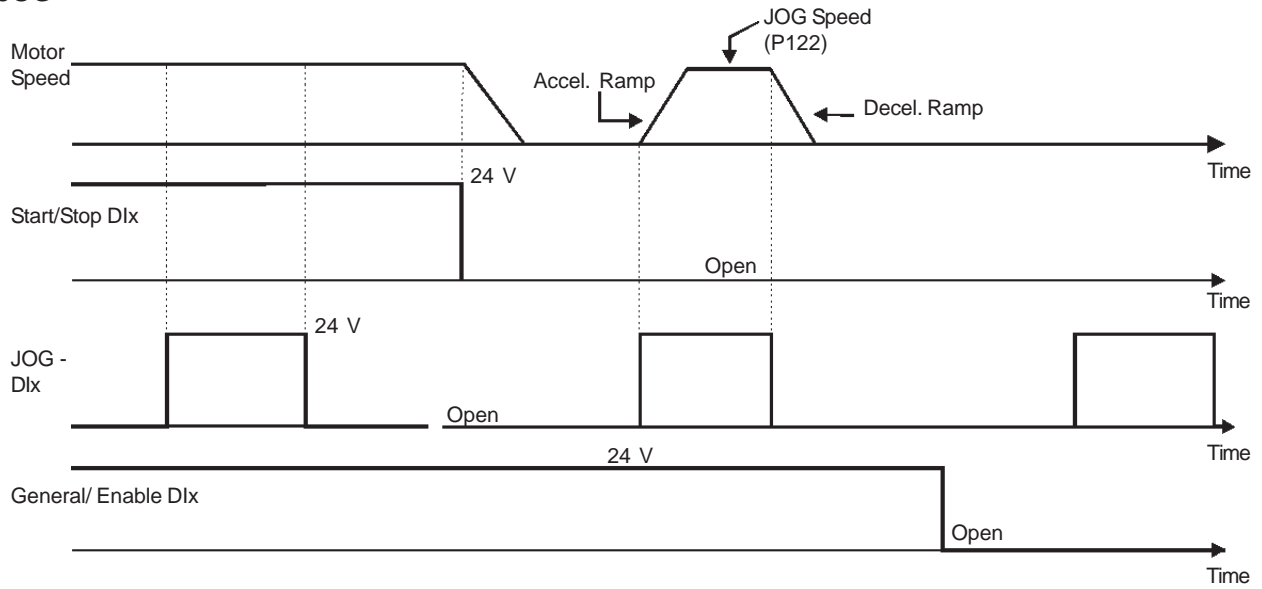

**i) JOG + and JOG -**

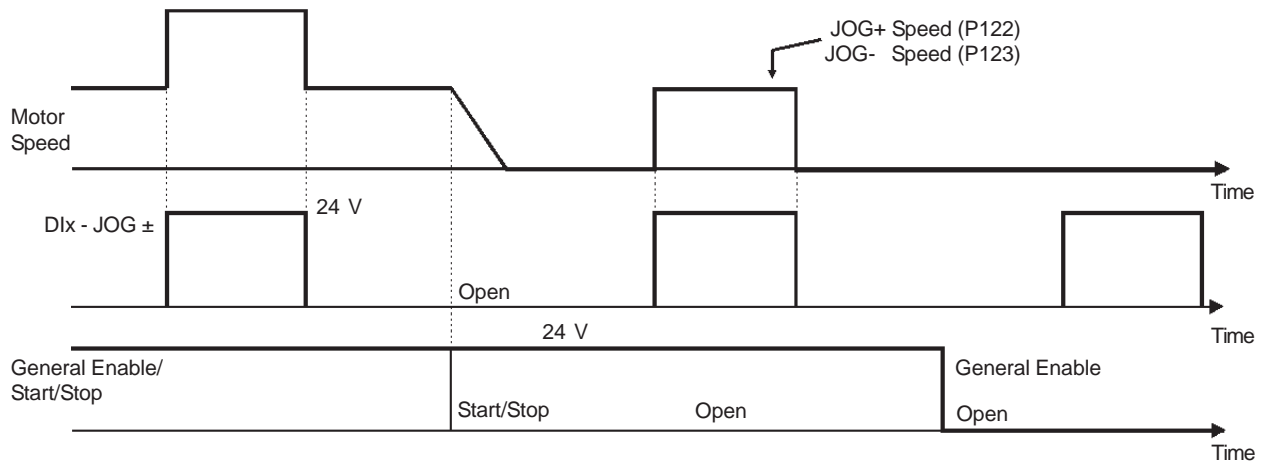

**j) RESET**

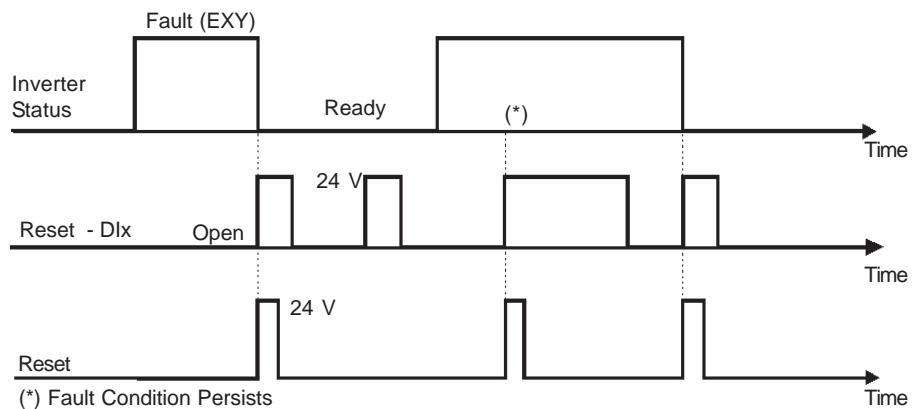
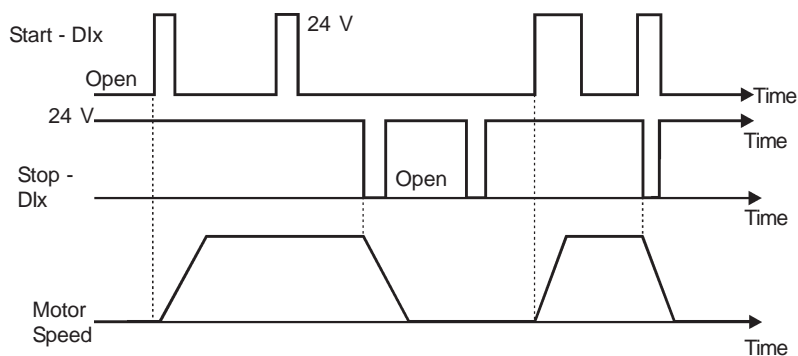
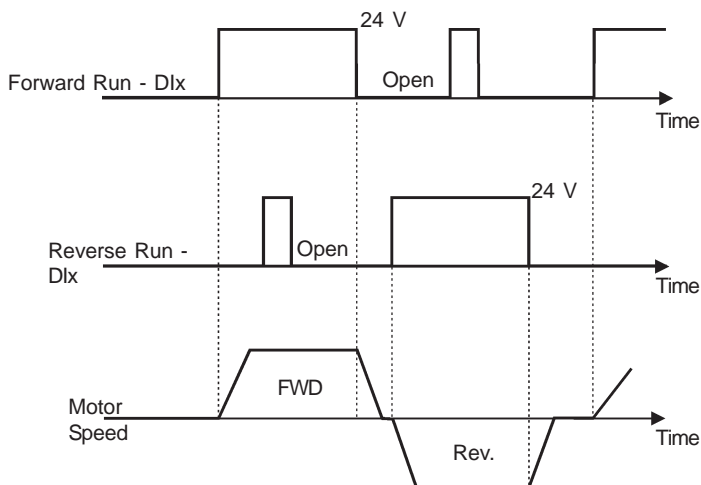

Figure 6.37 h) to j) - Details about the function of the Digital Inputs (cont.)

k) 3 WIRE START / STOP



l) FORWARD RUN / REVERSE RUN



m) ELECTRONIC POTENTIOMETER (EP)

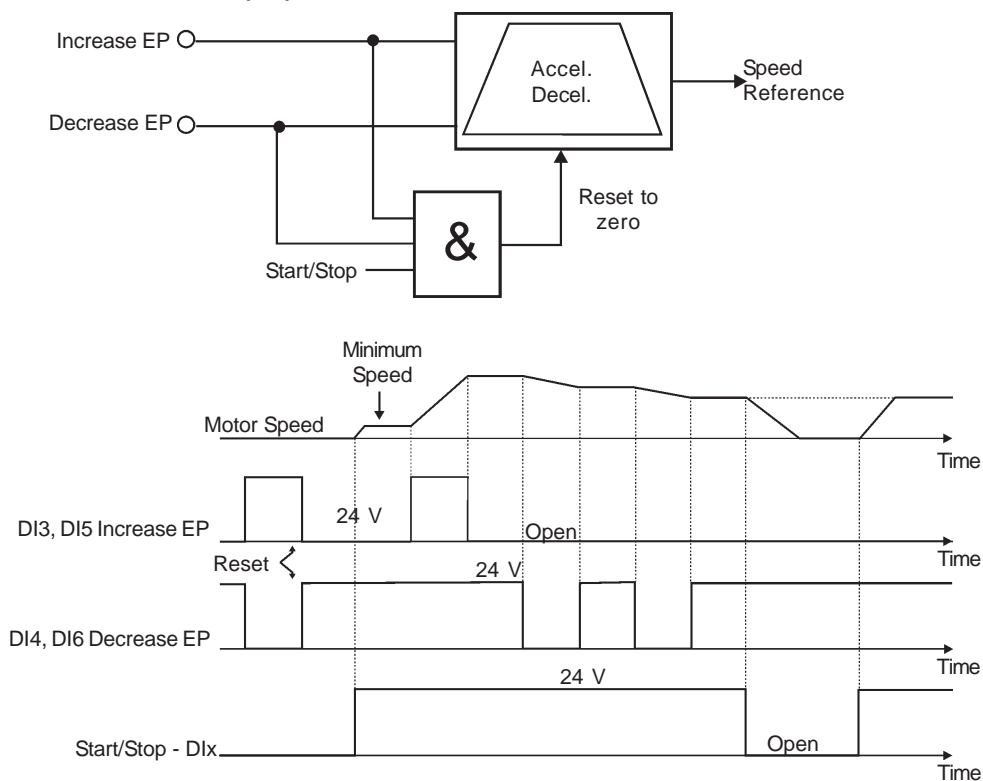



Figure 6.37 k) to m) - Details about the function of the Digital Inputs (cont.)

Parameter	Range [Factory Setting] Unit	Description / Notes																																																																																																																																																																																																																																																																																																						
<b>P275</b> <sup>(1)</sup> Digital Output DO1 Function (located on the Optional I/O Expansion Board EBA or EBB)	0 to 40 [ 0 (Not Used) ] -	<input checked="" type="checkbox"/> Check possible options on Table 6.40 and details about each function's operation on the charts in the figure 6.36. <input checked="" type="checkbox"/> The status of the Digital Outputs can be monitored at Parameter P013. <input checked="" type="checkbox"/> The Digital Output will be activated when the condition stated by it's function becomes true. In case of a Transistor Output, 24Vdc will be applied to the load connected to it. For a Relay Output, the relay will pick up when the output is activated.																																																																																																																																																																																																																																																																																																						
<b>P276</b> <sup>(1)</sup> Digital Output DO2 Function (located on the Optional I/O Expansion Board EBA or EBB)	0 to 40 [ 0 (Not Used) ] -	<table border="1"> <thead> <tr> <th>Function</th> <th>Parameter (Output)</th> <th>P275 (DO1)</th> <th>P276 (DO2)</th> <th>P277 (RL1)</th> <th>P279 (RL2)</th> <th>P280 (RL3)</th> </tr> </thead> <tbody> <tr><td>Not Used</td><td></td><td>0, 27 and 28</td><td>0, 27 and 28</td><td>0 and 28</td><td>0</td><td>0</td></tr> <tr><td>N* &gt; Nx</td><td></td><td>1</td><td>1</td><td>1</td><td>1</td><td>1</td></tr> <tr><td>N &gt; Nx</td><td></td><td>2</td><td>2</td><td>2</td><td>2</td><td>2</td></tr> <tr><td>N &lt; Ny</td><td></td><td>3</td><td>3</td><td>3</td><td>3</td><td>3</td></tr> <tr><td>N = N*</td><td></td><td>4</td><td>4</td><td>4</td><td>4</td><td>4</td></tr> <tr><td>Zero Speed</td><td></td><td>5</td><td>5</td><td>5</td><td>5</td><td>5</td></tr> <tr><td>Is &gt; Ix</td><td></td><td>6</td><td>6</td><td>6</td><td>6</td><td>6</td></tr> <tr><td>Is &lt; Ix</td><td></td><td>7</td><td>7</td><td>7</td><td>7</td><td>7</td></tr> <tr><td>Torque &gt; Tx</td><td></td><td>8</td><td>8</td><td>8</td><td>8</td><td>8</td></tr> <tr><td>Torque &lt; Tx</td><td></td><td>9</td><td>9</td><td>9</td><td>9</td><td>9</td></tr> <tr><td>Remote</td><td></td><td>10</td><td>10</td><td>10</td><td>10</td><td>10</td></tr> <tr><td>run</td><td></td><td>11</td><td>11</td><td>11</td><td>11</td><td>11</td></tr> <tr><td>ready</td><td></td><td>12</td><td>12</td><td>12</td><td>12</td><td>12</td></tr> <tr><td>No Fault</td><td></td><td>13</td><td>13</td><td>13</td><td>13</td><td>13</td></tr> <tr><td>No E00</td><td></td><td>14</td><td>14</td><td>14</td><td>14</td><td>14</td></tr> <tr><td>No E01+E02+E03</td><td></td><td>15</td><td>15</td><td>15</td><td>15</td><td>15</td></tr> <tr><td>No E04</td><td></td><td>16</td><td>16</td><td>16</td><td>16</td><td>16</td></tr> <tr><td>No E05</td><td></td><td>17</td><td>17</td><td>17</td><td>17</td><td>17</td></tr> <tr><td>4 to 20 mA OK</td><td></td><td>18</td><td>18</td><td>18</td><td>18</td><td>18</td></tr> <tr><td>Fieldbus</td><td></td><td>19</td><td>19</td><td>19</td><td>19</td><td>19</td></tr> <tr><td>FWD</td><td></td><td>20</td><td>20</td><td>20</td><td>20</td><td>20</td></tr> <tr><td>Proc. Var. &gt;VPx</td><td></td><td>21</td><td>21</td><td>21</td><td>21</td><td>21</td></tr> <tr><td>Proc. Var. &gt;VPy</td><td></td><td>22</td><td>22</td><td>22</td><td>22</td><td>22</td></tr> <tr><td>Ride-Through</td><td></td><td>23</td><td>23</td><td>23</td><td>23</td><td>23</td></tr> <tr><td>Pre-charge OK</td><td></td><td>24</td><td>24</td><td>24</td><td>24</td><td>24</td></tr> <tr><td>With error</td><td></td><td>25</td><td>25</td><td>25</td><td>25</td><td>25</td></tr> <tr><td>Enabled Hours &gt; Hx</td><td></td><td>26</td><td>26</td><td>26</td><td>26</td><td>26</td></tr> <tr><td>PLC</td><td></td><td>-</td><td>-</td><td>27</td><td>27</td><td>27</td></tr> <tr><td>Timer</td><td></td><td>-</td><td>-</td><td>-</td><td>28</td><td>28</td></tr> <tr><td>N &gt; Nx and Nt &gt; Nx</td><td></td><td>29</td><td>29</td><td>29</td><td>29</td><td>29</td></tr> <tr><td>Brake (Vel) - Real Speed</td><td></td><td>30</td><td>30</td><td>30</td><td>30</td><td>30</td></tr> <tr><td>Brake (Ref) - Total Reference</td><td></td><td>31</td><td>31</td><td>31</td><td>31</td><td>31</td></tr> <tr><td>Overweight</td><td></td><td>32</td><td>32</td><td>32</td><td>32</td><td>32</td></tr> <tr><td>Slack Cable</td><td></td><td>33</td><td>33</td><td>33</td><td>33</td><td>33</td></tr> <tr><td>Torque Polarity +/-</td><td></td><td>34</td><td>34</td><td>34</td><td>34</td><td>34</td></tr> <tr><td>Torque Polarity -/+</td><td></td><td>35</td><td>35</td><td>35</td><td>35</td><td>35</td></tr> <tr><td>F &gt; Fx _ 1</td><td></td><td>36</td><td>36</td><td>36</td><td>36</td><td>36</td></tr> <tr><td>F &gt; Fx _ 2</td><td></td><td>37</td><td>37</td><td>37</td><td>37</td><td>37</td></tr> <tr><td>Set point = Process Variable</td><td></td><td>38</td><td>38</td><td>38</td><td>38</td><td>38</td></tr> <tr><td>No E32</td><td></td><td>39</td><td>39</td><td>39</td><td>39</td><td>39</td></tr> <tr><td>Ready 2</td><td></td><td>40</td><td>40</td><td>40</td><td>40</td><td>40</td></tr> </tbody> </table>	Function	Parameter (Output)	P275 (DO1)	P276 (DO2)	P277 (RL1)	P279 (RL2)	P280 (RL3)	Not Used		0, 27 and 28	0, 27 and 28	0 and 28	0	0	N* > Nx		1	1	1	1	1	N > Nx		2	2	2	2	2	N < Ny		3	3	3	3	3	N = N*		4	4	4	4	4	Zero Speed		5	5	5	5	5	Is > Ix		6	6	6	6	6	Is < Ix		7	7	7	7	7	Torque > Tx		8	8	8	8	8	Torque < Tx		9	9	9	9	9	Remote		10	10	10	10	10	run		11	11	11	11	11	ready		12	12	12	12	12	No Fault		13	13	13	13	13	No E00		14	14	14	14	14	No E01+E02+E03		15	15	15	15	15	No E04		16	16	16	16	16	No E05		17	17	17	17	17	4 to 20 mA OK		18	18	18	18	18	Fieldbus		19	19	19	19	19	FWD		20	20	20	20	20	Proc. Var. >VPx		21	21	21	21	21	Proc. Var. >VPy		22	22	22	22	22	Ride-Through		23	23	23	23	23	Pre-charge OK		24	24	24	24	24	With error		25	25	25	25	25	Enabled Hours > Hx		26	26	26	26	26	PLC		-	-	27	27	27	Timer		-	-	-	28	28	N > Nx and Nt > Nx		29	29	29	29	29	Brake (Vel) - Real Speed		30	30	30	30	30	Brake (Ref) - Total Reference		31	31	31	31	31	Overweight		32	32	32	32	32	Slack Cable		33	33	33	33	33	Torque Polarity +/-		34	34	34	34	34	Torque Polarity -/+		35	35	35	35	35	F > Fx _ 1		36	36	36	36	36	F > Fx _ 2		37	37	37	37	37	Set point = Process Variable		38	38	38	38	38	No E32		39	39	39	39	39	Ready 2		40	40	40	40	40
Function	Parameter (Output)	P275 (DO1)	P276 (DO2)	P277 (RL1)	P279 (RL2)	P280 (RL3)																																																																																																																																																																																																																																																																																																		
Not Used		0, 27 and 28	0, 27 and 28	0 and 28	0	0																																																																																																																																																																																																																																																																																																		
N* > Nx		1	1	1	1	1																																																																																																																																																																																																																																																																																																		
N > Nx		2	2	2	2	2																																																																																																																																																																																																																																																																																																		
N < Ny		3	3	3	3	3																																																																																																																																																																																																																																																																																																		
N = N*		4	4	4	4	4																																																																																																																																																																																																																																																																																																		
Zero Speed		5	5	5	5	5																																																																																																																																																																																																																																																																																																		
Is > Ix		6	6	6	6	6																																																																																																																																																																																																																																																																																																		
Is < Ix		7	7	7	7	7																																																																																																																																																																																																																																																																																																		
Torque > Tx		8	8	8	8	8																																																																																																																																																																																																																																																																																																		
Torque < Tx		9	9	9	9	9																																																																																																																																																																																																																																																																																																		
Remote		10	10	10	10	10																																																																																																																																																																																																																																																																																																		
run		11	11	11	11	11																																																																																																																																																																																																																																																																																																		
ready		12	12	12	12	12																																																																																																																																																																																																																																																																																																		
No Fault		13	13	13	13	13																																																																																																																																																																																																																																																																																																		
No E00		14	14	14	14	14																																																																																																																																																																																																																																																																																																		
No E01+E02+E03		15	15	15	15	15																																																																																																																																																																																																																																																																																																		
No E04		16	16	16	16	16																																																																																																																																																																																																																																																																																																		
No E05		17	17	17	17	17																																																																																																																																																																																																																																																																																																		
4 to 20 mA OK		18	18	18	18	18																																																																																																																																																																																																																																																																																																		
Fieldbus		19	19	19	19	19																																																																																																																																																																																																																																																																																																		
FWD		20	20	20	20	20																																																																																																																																																																																																																																																																																																		
Proc. Var. >VPx		21	21	21	21	21																																																																																																																																																																																																																																																																																																		
Proc. Var. >VPy		22	22	22	22	22																																																																																																																																																																																																																																																																																																		
Ride-Through		23	23	23	23	23																																																																																																																																																																																																																																																																																																		
Pre-charge OK		24	24	24	24	24																																																																																																																																																																																																																																																																																																		
With error		25	25	25	25	25																																																																																																																																																																																																																																																																																																		
Enabled Hours > Hx		26	26	26	26	26																																																																																																																																																																																																																																																																																																		
PLC		-	-	27	27	27																																																																																																																																																																																																																																																																																																		
Timer		-	-	-	28	28																																																																																																																																																																																																																																																																																																		
N > Nx and Nt > Nx		29	29	29	29	29																																																																																																																																																																																																																																																																																																		
Brake (Vel) - Real Speed		30	30	30	30	30																																																																																																																																																																																																																																																																																																		
Brake (Ref) - Total Reference		31	31	31	31	31																																																																																																																																																																																																																																																																																																		
Overweight		32	32	32	32	32																																																																																																																																																																																																																																																																																																		
Slack Cable		33	33	33	33	33																																																																																																																																																																																																																																																																																																		
Torque Polarity +/-		34	34	34	34	34																																																																																																																																																																																																																																																																																																		
Torque Polarity -/+		35	35	35	35	35																																																																																																																																																																																																																																																																																																		
F > Fx _ 1		36	36	36	36	36																																																																																																																																																																																																																																																																																																		
F > Fx _ 2		37	37	37	37	37																																																																																																																																																																																																																																																																																																		
Set point = Process Variable		38	38	38	38	38																																																																																																																																																																																																																																																																																																		
No E32		39	39	39	39	39																																																																																																																																																																																																																																																																																																		
Ready 2		40	40	40	40	40																																																																																																																																																																																																																																																																																																		
<b>P277</b> <sup>(1)</sup> Relay Output RL1 Function	0 to 40 [ 13 (No Fault) ] -																																																																																																																																																																																																																																																																																																							
<b>P279</b> <sup>(1)</sup> Relay Output RL2 Function	0 to 40 [ 2 (N>Nx) ] -																																																																																																																																																																																																																																																																																																							
<b>P280</b> <sup>(1)</sup> Relay Output RL3 Function	0 to 40 [ 1 (N*>Nx) ] -																																																																																																																																																																																																																																																																																																							

Table 6.40 - Functions of the Digital Outputs and Relay Outputs

Parameter	Range [Factory Setting] Unit	Description / Notes
		<p><input checked="" type="checkbox"/> Additional Notes about the Digital Output Functions:</p> <ul style="list-style-type: none"> <li>- <b>Remote:</b> Inverter is operating in Remote mode.</li> <li>- <b>Run:</b> Inverter is enabled (the IGBTs are switching, the motor may be at any speed, including zero).</li> <li>- <b>Ready:</b> Inverter neither is in fault non in undervoltage condition.</li> <li>- <b>No Fault:</b> Inverter is not in any fault condition.</li> <li>- <b>With Error</b> means that the inverter is disabled due to some error.</li> <li>- <b>No E00:</b> Inverter is not in an E00 fault condition.</li> <li>- <b>No E01+E02+E03:</b> Inverter is not in an E01 or E02 or E03 fault condition.</li> <li>- <b>No E04:</b> Inverter is not in an E04 fault condition.</li> <li>- <b>No E05:</b> Inverter is not in an E05 fault condition.</li> <li>- <b>4 to 20mA OK:</b> If applicable, the 4 to 20 mA current reference is present.</li> <li>- <b>Zero Speed:</b> Motor speed is lower than the value set at P291 (Zero Speed Zone)</li> <li>- <b>Not Used:</b> Digital Output remains inactive.</li> <li>- <b>Forward:</b> Motor is running forward.</li> <li>- <b>Torque &gt; Tx and Torque &lt; Tx:</b> Valid only for P202 = 3 or 4 (Vector Control). Torque corresponds to motor Torque as indicated in Parameter P009.</li> <li>- <b>Ride-Through:</b> means that the inverter is executing the Ride-Through function.</li> <li>- <b>Pre-charge OK:</b> means that the DC-Link voltage is higher than the pre-charge voltage level.</li> <li>- <b>Fieldbus:</b> allows changing the state of the digital outputs (P275 to P280) from the Fieldbus network. Refer to item 8.12.5.2.</li> <li>- <b>N &gt; Nx and Nt &gt; Nx:</b> (this option works only for P202=4 - Vector with Encoder Control) means that both conditions must be satisfied in order that DOx = Saturated Transistor and/or RLx= relay picked up. The Digital Outputs will come back to its OFF state, that is, DOx = Cut-off Transistor and/or RLx = released relay, when only <b>N&gt;Nx</b> condition is not satisfied (that is, independent of <b>Nt&gt;Nx</b> condition).</li> <li>- <b>Timer:</b> This times enable and disable the relays 2 and 3 (refer P283 to P286).</li> <li>- <b>Brake (Vel) – Real Speed</b> It uses the Real Speed in the comparison of N &gt; Nx to activate the brake. Note: Nx is programmable at P288.</li> <li>- <b>Brake (Ref) – Total Reference</b> If P202 = 3 (Sensorless Control) – It uses the Total Reference in the comparison of N* &gt; Nx to activate the brake.</li> </ul>

Parameter	Range [Factory Setting] Unit	Description / Notes
		<p>If P202 ≠ 3 (V/F, VVW or Vector with Encoder control), the comparison of <math>N &gt; N_x</math> to activate the brake will always use the Real Speed, regardless of the selection (“31=Brake (Ref)” or “30=Brake (Vel)”).</p> <p> <b>NOTE!</b> Refer to figures 6.39 q), r) and s)</p> <p>Preliminary settings:</p> <p><math>N_x</math> (P288) = 7% to 10% of the motor speed (sensorless control), 2% to 5% of the speed (vector with encoder control)</p> <p><math>I_x</math> (P290) = 20% to 130% of P401</p> <p>P355 = 0 seconds</p> <p>P354 = 1.5 x time to activate the brake</p> <p>P356 = 0.85 x time to release the brake</p> <p>P353 = 0.2 seconds</p> <p> <b>NOTE!</b> These preliminary settings are suggestive and may be changed according to the application.</p> <p>- <b>Overweight</b> - Situation where the lifted load weight is greater than the maximum allowed.</p> <p><input checked="" type="checkbox"/> When the CFW09 is powered up, the output set to the option “32 = Overweight” is activated. In order to deactivate the output, i.e., detect the overweight condition, the following conditions shall be satisfied:</p> <ul style="list-style-type: none"> <li>- P361 = 1 (Load Detection = On);</li> <li>- Parameters P362, P363 and P367 properly set;</li> <li>- P367 (Overweight Level) lower than the output current (<math>P367 &lt; I_s</math>) during the stabilization time.</li> </ul> <p><input checked="" type="checkbox"/> If P361 = 0 (Load Detection = Off) – the output always remains activated.</p> <p>- <b>Slack Cable</b> - Situation where the lifted load weight is lower than the minimum weight detected by the crane.</p> <p><input checked="" type="checkbox"/> When the CFW09 is powered up, the output set to the option “33 = Slack Cable” is activated. In order to deactivate the output, i.e., detect the slack cable condition, the following conditions shall be satisfied:</p> <ul style="list-style-type: none"> <li>- P361 = 1 (Load Detection = On);</li> <li>- Parameters P362, P363, P364 and P365 properly set;</li> <li>- Slack cable condition detected.</li> </ul>

Parameter	Range [Factory Setting] Unit	Description / Notes
-----------	------------------------------------	---------------------

 **NOTES!**

- If the slack cable condition is detected during the stabilization time, the motor remains at the stabilization speed until receiving a “Stop” command. However, if this condition is detected outside of the stabilization time, the output set to this option will be deactivated and the motor will maintain the same speed.
- The only way of disabling the Slack Cable function is stopping the motor.
- To a better understanding refer to figures 6.47 a) and b).
- If P361 = 0 (Load Detection = Off) – the output always remains activated.

**- Torque Polarity +/-**

The output programmed to this function will be activated when the torque is positive.

**- Torque Polarity -/+**

The output programmed to this function will be activated when the torque is negative.

 **NOTE!**

The outputs that are set to the function “Torque Polarity” have a hysteresis in its operation that can be configured at parameter P358 (Hysteresis for the Torque Current – Iq). This resource works in the transition of these outputs at the moment they are activated or deactivated.

**DOx or RLx = 34 – Torque Polarity +/-**

Torque Polarity	XC4 Voltage DO1 (5, 6) DO2 (7, 6)	Status of the contacts at XC1				
		(NC) RL1	(NO) RL2	(NO) RL2	(NC) RL3	(NO) RL3
		21-24	22-24	23-25	25-26	27-28
Positive (+)	0V	Open	Closed	Closed	Open	Closed
Negative (-)	+24V	Closed	Open	Open	Closed	Open

*Table 6.42 a) - Status of the DOx and RLx contacts with the torque polarity +/- function*

**DOx or RLx = 35 – Torque Polarity -/+**

Torque Polarity	XC4 Voltage DO1 (5, 6) DO2 (7, 6)	Status of the contacts at XC1				
		(NC) RL1	(NO) RL2	(NO) RL2	(NC) RL3	(NO) RL3
		21-24	22-24	23-25	25-26	27-28
Positive (+)	+24V	Closed	Open	Open	Closed	Open
Negative (-)	0V	Open	Closed	Closed	Open	Closed

*Table 6.42 b) - Status of the DOx and RLx contacts with the torque polarity +/- function*

Parameter	Range [Factory Setting] Unit	Description / Notes
-----------	------------------------------------	---------------------

 **NOTE!**

It is used only with the Master/Slave function to indicate the torque polarity at the digital or relay outputs.

**Description of the Torque Polarity +/- function for the Torque Master/Slave function**

The implementation of this function requires the digital or relay outputs of the “master” CFW-09 to be set to the options P275=34 (Torque Polarity +/-) or P275=35 (Torque Polarity -/+).

Therefore, a load resistor (Rc) shall be connected at the digital output DO1 (XC4:5) or DO2 (XC4:7), as presented in figure 8.1. This output shall be connected to the digital input DI2 of the “Slave” CFW-09, which shall be set to the option P264=0 (Direction of Rotation).

In the master CFW-09 (Vector with encoder):	In the slave CFW-09 (Vector with encoder):
P275 or P276=34 or 35; P357= 0.1s P358= 2.00% P253=4	P100=P101=0; P160=1; P223=P226=DI2=4; P264=0 P237=2 P234=1.2

**Table 6.43** - Minimum required settings for the torque Master/Slave function

For P275 or P276 = 34 or 35

- When the torque current of the “master” CFW-09 is positive, the digital output DO1 or DO2 will be set to zero, which will force the speed regulator of the “slave” to saturate positively, producing a positive torque current.
- When the torque current of the “master” CFW-09 is negative, the digital output DO1 or DO2 will be set to 24V, which will force the speed regulator of the “slave” to saturate negatively, producing a negative torque current.

Parameter	Range [Factory Setting] Unit	Description / Notes
-----------	------------------------------------	---------------------

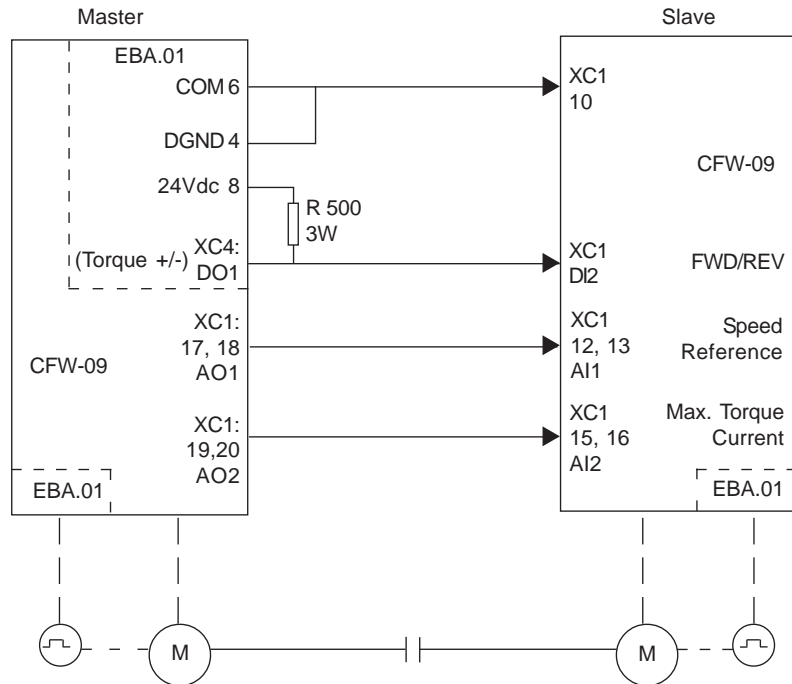

Figure 6.38 - Diagram for the Torque Master/Slave function

- **F > Fx\_ 1:** This function activates the relay and/or transistorized outputs set to this option when the output frequency value (F) is greater than the value set at P369 (Fx) plus the hysteresis value set at P370. When  $F < Fx - P370$ , the outputs set to this option are deactivated (refer to figure 6.39 t).
- **F > Fx\_ 2:** With this option the hysteresis for the acceleration is disabled, therefore, this function activates the relay and/or transistorized outputs set to this option when the output frequency value (F) is greater than the value set at P369 (Fx). When  $F < Fx - P370$ , the outputs set to this option are deactivated (refer to figure 6.39 v).
- **Set point = Process Variable.** This function activates the digital or relay output when the Set point value equals the Process Variable value (refer to figure 6.39 v).
- **No E32** - It indicates that the drive is disabled due to an E32 error.
- **Ready 2** - Indicates that the motor is disabled (motor stopped) without error and without undervoltage.

Symbols used in the Digital Output functions:

**N** = P002 (Motor speed)

**N\*** = P001 (Frequency Reference)

**Nx** = P288 (Speed Nx) - User selected speed reference point.

**Ny** = P289 (Speed Ny) - User selected speed reference point.

Parameter	Range [Factory Setting] Unit	Description / Notes
		<p><b>Ix</b> = P290 (Current Ix) - User selected current reference point.</p> <p><b>Is</b> = P003 (Motor Current)</p> <p><b>Torque</b> = P009 (Motor Torque)</p> <p><b>Tx</b> = P293 (Torque Tx) - User selected torque reference point.</p> <p><b>Vpx</b> = P533 (Process Variable x) - User selected reference point.</p> <p><b>Vpy</b> = P534 (Process Variable y) - User selected reference point.</p> <p><b>Nt</b> = Total Reference (See Figure 6.26) after all scalings, offsets, additions, etc.</p> <p><b>Hx</b> = P294 (Hours Hx)</p> <p><b>PLC</b> = See PLC board manual</p> <p><b>Fx</b> = P370 (Frequency Fx) – Frequency reference defined by the user.</p>
<p><b>P283</b> Time for RL2 ON</p>	<p>0.0 to 300 [ 0.0 ] 0.1s</p>	<p><input checked="" type="checkbox"/> Used in the function as Relay Output: Timer of the relay 2 or 3.</p> <p><input checked="" type="checkbox"/> When the timing function of the relays 2 and 3 is programmed at any Dlx, and when the transition is effected from 0V to 24V, the relay will be enabled according to the time set at P283 (RL2) or P285 (RL3). When the transition from 24V to 0V occurs, the programmed relay will be disabled according to the time set at P284(RL2) or P286(RL3).</p>
<p><b>P284</b> Time for RL2 OFF</p>	<p>0.0 to 300 [ 0.0 ] 0.1s</p>	
<p><b>P285</b> Time for RL3 ON</p>	<p>0.0 to 300 [ 0.0 ] 0.1s</p>	<p><input checked="" type="checkbox"/> After the Dlx transition, to enable or disable the programmed relay, it is required that the Dlx remains in on/off status during the time set at parameters P283/P285 and P284/P286. Otherwise the relay will be reset. See figure 6.34.</p>
<p><b>P286</b> Time for RL3 OFF</p>	<p>0.0 to 300 [ 0.0 ] 0.1s</p>	<p>Note: For this function, program P279 and/or P280 = 28 (Timer).</p>

a)  $N > N_x$

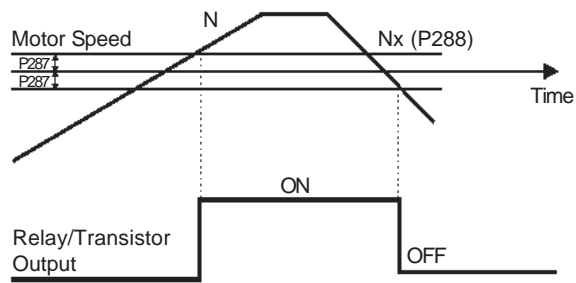

b)  $N < N_y$

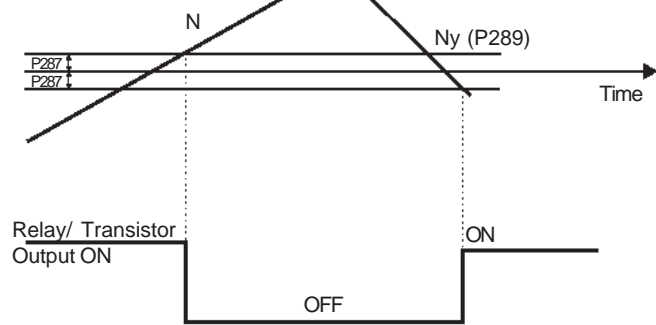

c)  $N = N^*$

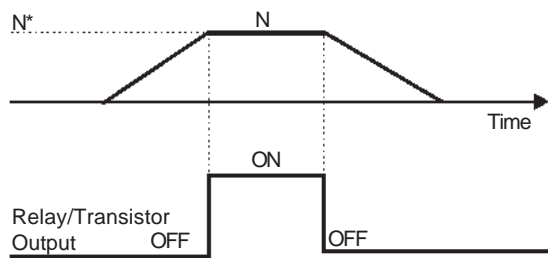

d)  $I_s > I_x$

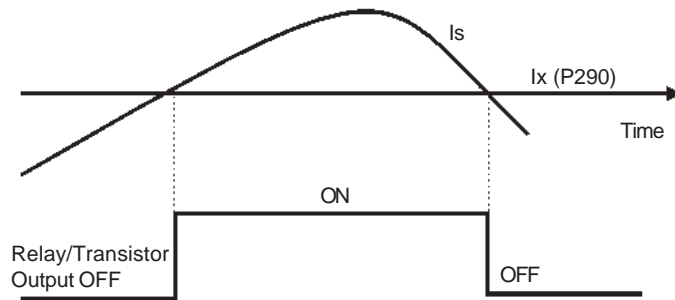

e)  $N^* > N_x$

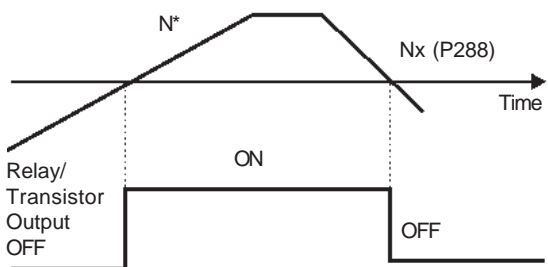

f)  $I_s < I_x$

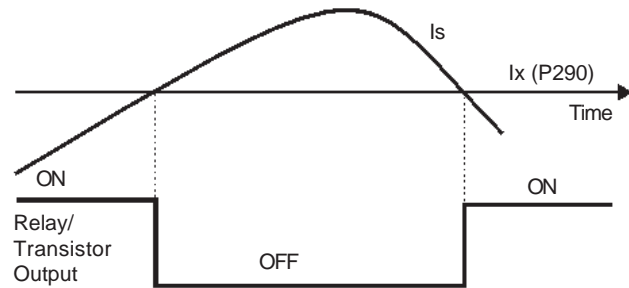

g) Torque  $> T_x$

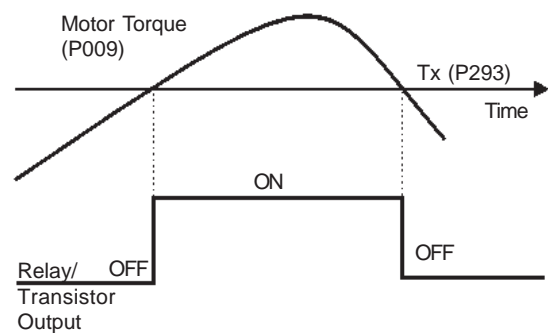

h) Torque  $< T_x$

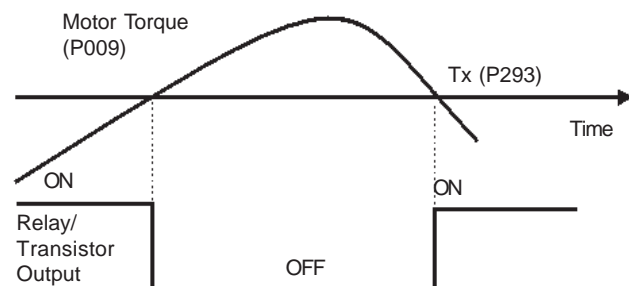
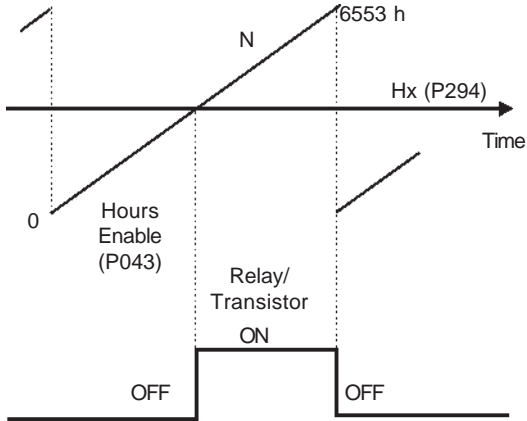
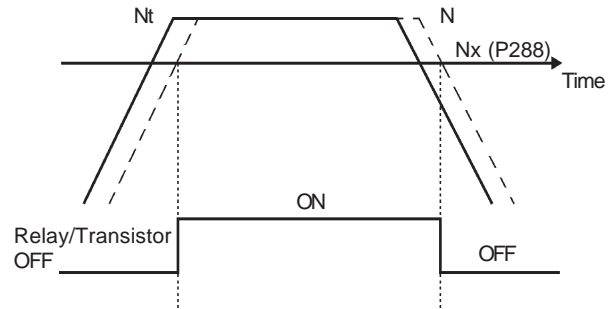

Figure 6.39 a) to h) - Details about the operation of the Digital and Relay Output Functions

i) Enabled Hours > Nx



j)  $N > N_x$  and  $N_t > N_x$



k) No External Fault

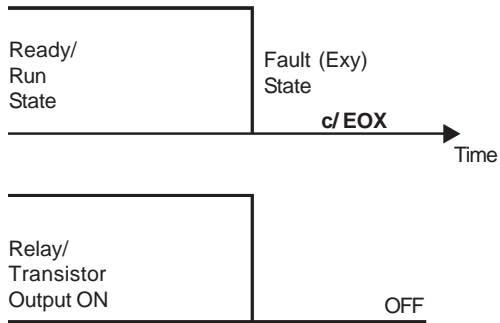

l) 4 to 20mA OK

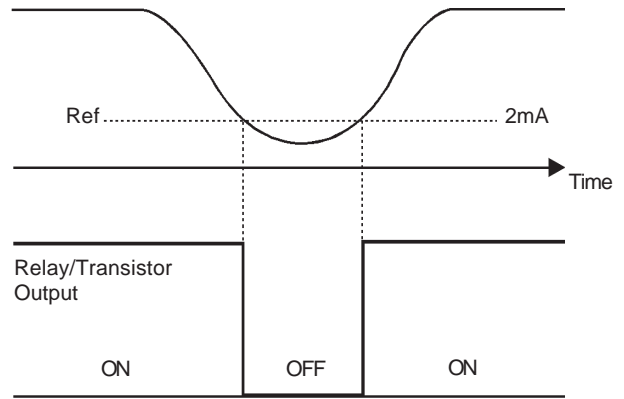

m)  $N = 0$

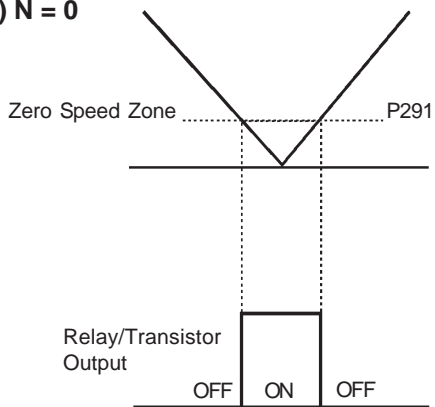

n) Process Var. > VPx

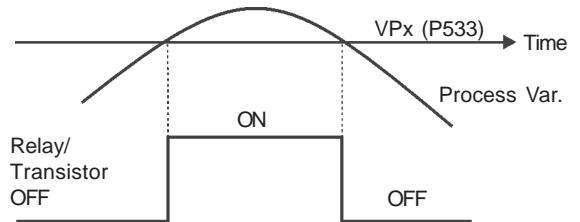

o) Pre charge Ok

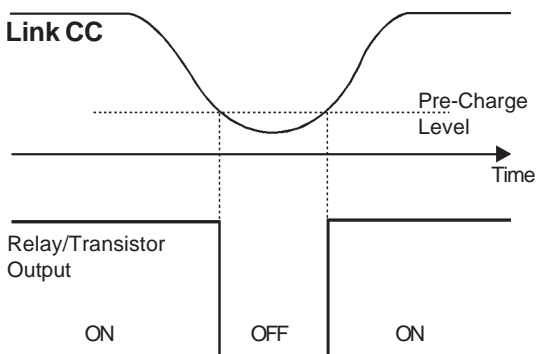

p) Process Var. < VPy

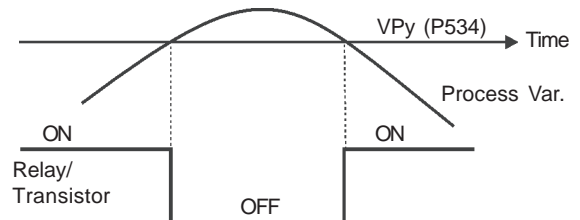
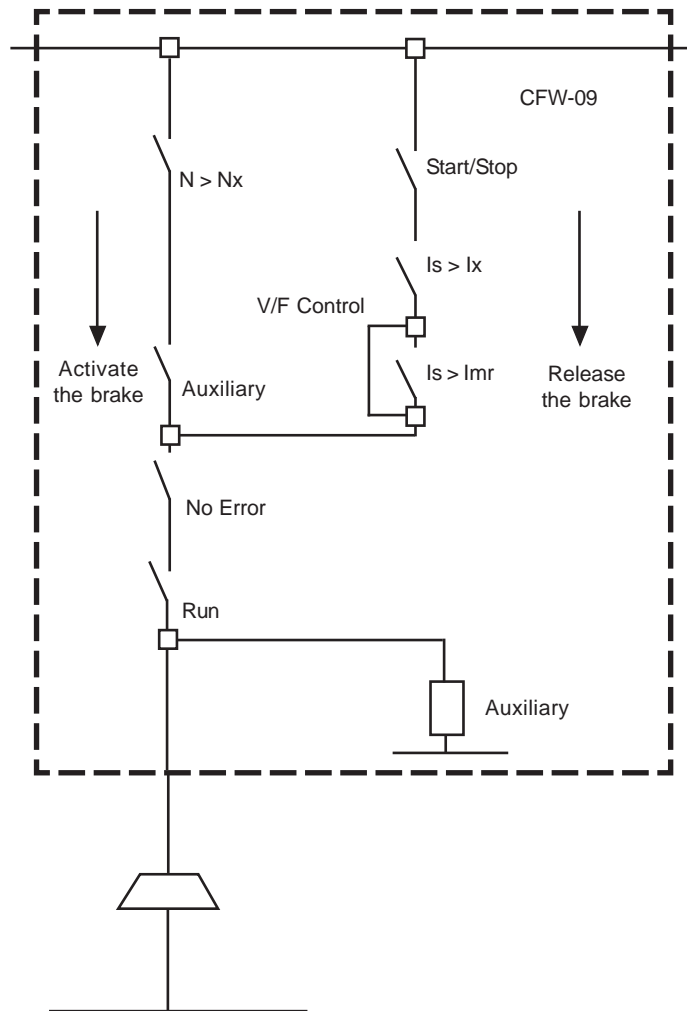

Figure 6.39 i) to p) - Details about the operation of the Digital and Relay Output Functions (cont.)

q) Logic for the Brake Activation when DOx or Relay = 30 or 31



**NOTES!**

- 1) To release the brake (transition from NC to NO) both comparisons are performed  $I_s > I_x$ ,  $I_s > I_{mr}$ . At the same time, the drive shall receive a Start/Stop command in the "Run" state and with no error.
- 2) To activate the brake (transition from NO to NC) the comparison  $N > N_x$  is performed.
- 3) If  $P202=4$  (Vector with Encoder), the brake is not activated when the speed crosses zero at the reversing of the direction of rotation.

Figure 6.39 q) - Details about the operation of the Digital and Relay Output Functions (cont.)

r) Operation of parameters P353 to P356 with  $I_x > I_{mr}$ .

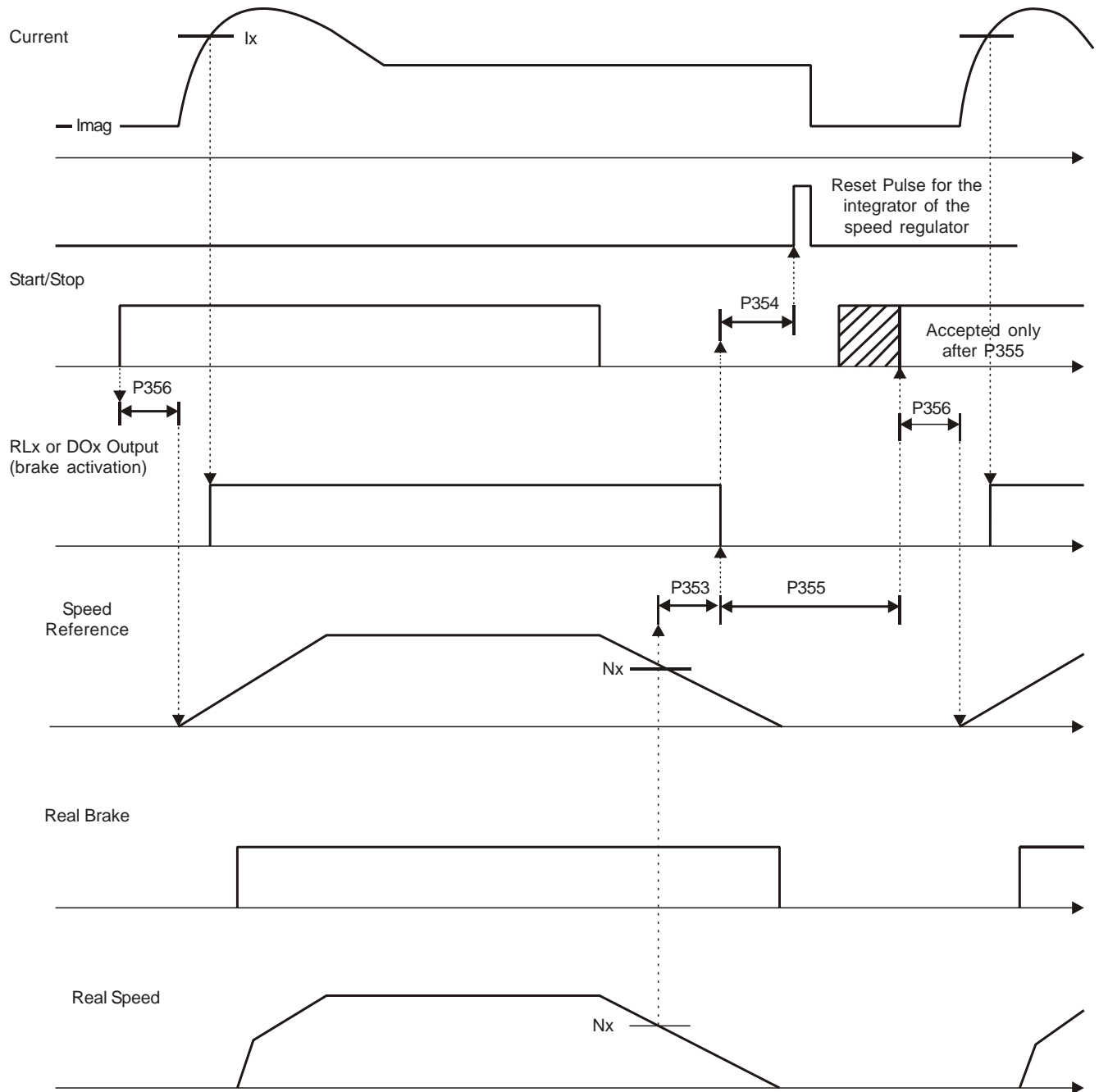

**Note:** The Start/Stop function in the figure above is valid only for commands from the DI1 (Digital Input #1) set to the option "1=Start/Stop".

Figure 6.39 r) - Details about the operation of the Digital and Relay Output Functions (cont.)

s) Operation of parameters P353 to P356 with  $I_x < I_{mr}$ .

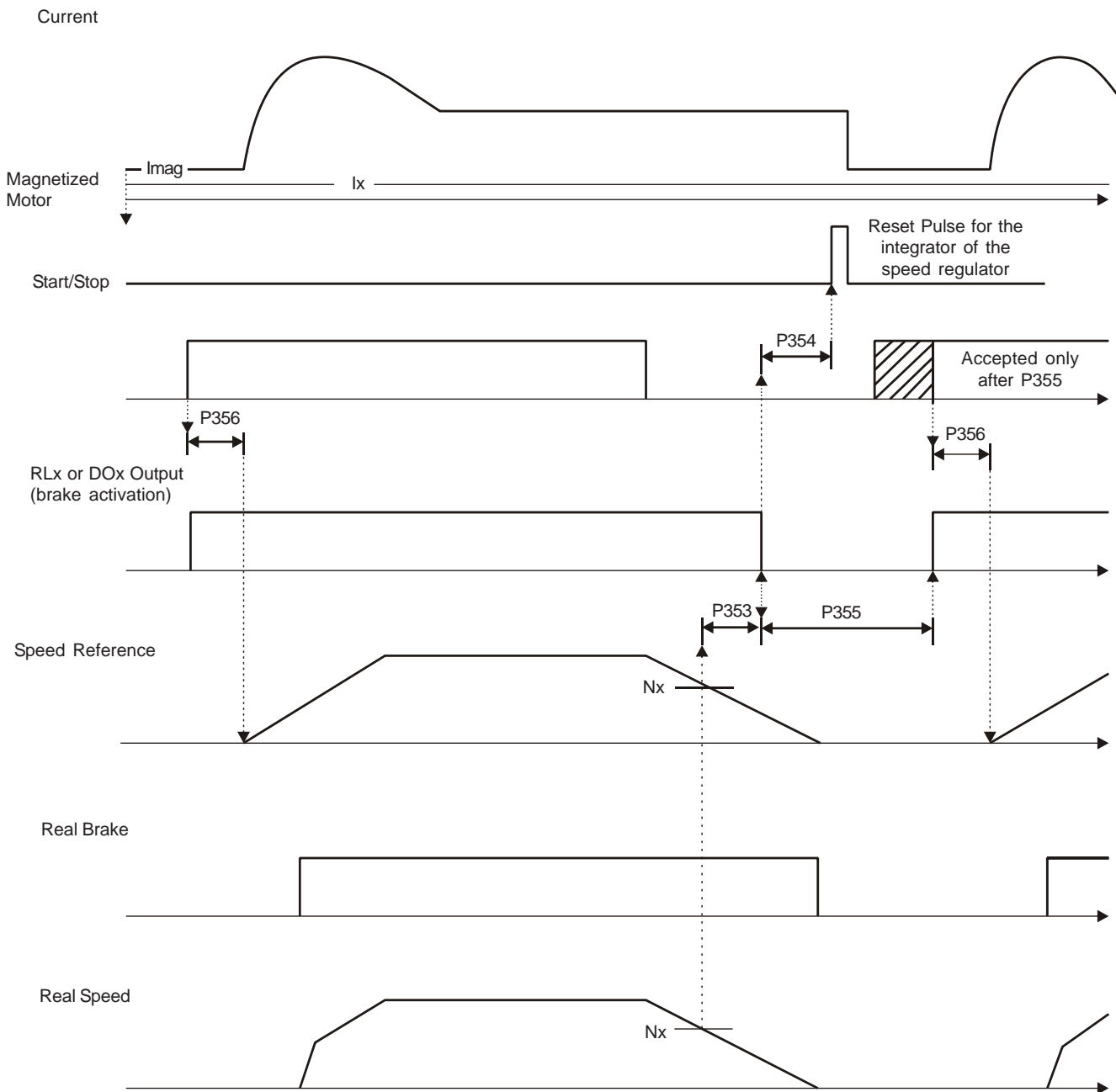
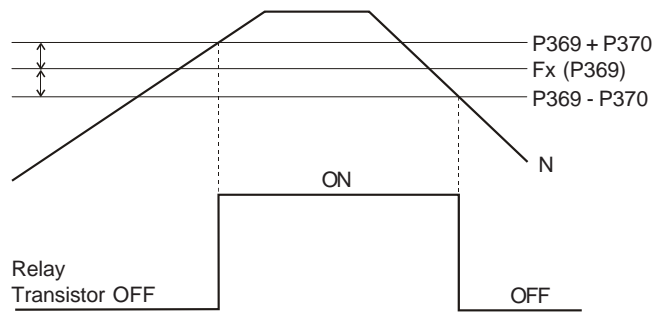
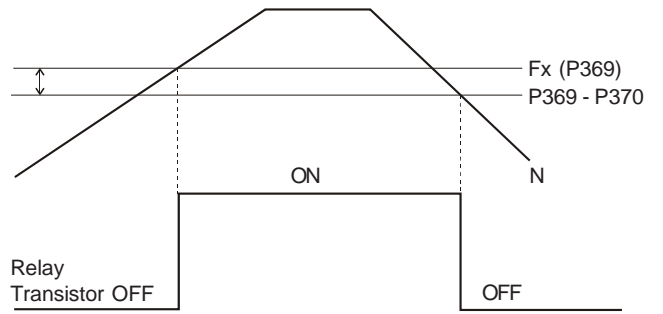

Figure 6.39 s) - Details about the operation of the Digital and Relay Output Functions (cont.)

t)  $F > Fx\_1$



u)  $F > Fx\_2$



v) Set point = Process Variable

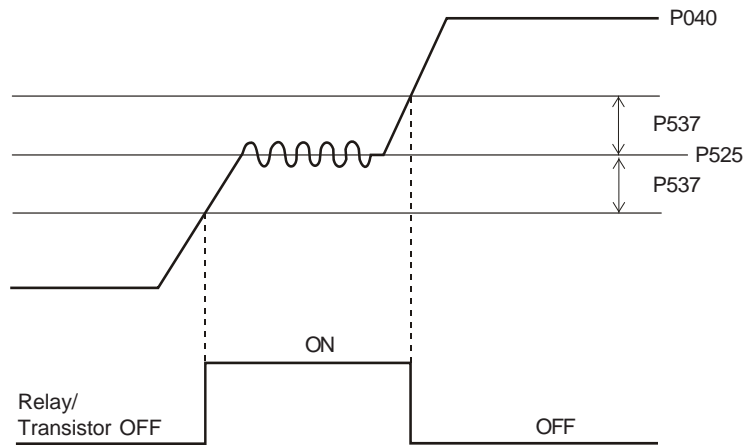



Figure 6.39 t) to v) - Details about the operation of the Digital and Relay Output Functions (cont.)

**CHAPTER 6 - DETAILED PARAMETER DESCRIPTION**

<b>Parameter</b>	<b>Range [Factory Setting] Unit</b>	<b>Description / Notes</b>
<b>P287</b> Hysteresis for Nx/Ny	0 to 5% [ 1.0 ] 0.1	<input checked="" type="checkbox"/> Used by the Digital and Relay Outputs functions: N > Nx and N < Ny.
<b>P288</b> <sup>(2) (11)</sup> Nx Speed	0 to P134 [ 120 (100) ] <sup>(11)</sup> 1rpm	<input checked="" type="checkbox"/> Used by the Digital and Relay Outputs functions: N* > Nx, N > Nx and N < Ny.
<b>P289</b> <sup>(2) (11)</sup> Ny Speed	0 to P134 [ 1800 (1500) ] <sup>(11)</sup> 1rpm	
<b>P290</b> <sup>(7)</sup> Ix Current	0.0 to 2.0 x P295 [ 1.0 x P295 ] 0.1A(<100)-1A(>99.9)	<input checked="" type="checkbox"/> Used by the Digital and Relay Outputs functions: Is > Ix and Is < Ix.
<b>P291</b> Zero Speed Zone	1 to 100 [ 1 ] 1%	<input checked="" type="checkbox"/> Used by the Digital and Relay Outputs function Zero Speed and the Zero Speed Disable (Refer to P211 and P212).
<b>P292</b> N=N* Band (At Speed Band)	1 to 100 [ 1 ] 1%	<input checked="" type="checkbox"/> Used by the Digital and Relay Outputs function N = N* (At Speed).
<b>P293</b> Tx Torque	0 to 200 [ 100 ] 1%	<input checked="" type="checkbox"/> Used by the Digital and Relay Outputs functions Torque > Tx and Torque < Tx. In this output mode, the motor torque indicated in parameter P009 is compared with the value programmed in P293. <input checked="" type="checkbox"/> The setting is expressed in % of the motor rated current (P401=100%)
<b>P294</b> Hours Hx	0 to 6553h [ 4320 ] 1.0	<input checked="" type="checkbox"/> Used in the functions of the digital outputs Hours Enabled higher than Hx.

Parameter	Range [Factory Setting] Unit	Description / Notes																																																																																																																																																																				
<b>P295</b> <sup>(1)</sup> Inverter Rated Current	0 to 81 [ According to the CFW-09 rated current for CT application] -	<input checked="" type="checkbox"/> Even if some models withstand a higher current for VT applications, the setting of P295 shall be kept in accordance with the drive rated current (CT). <input checked="" type="checkbox"/> Do not modify the value of P295 for VT applications.																																																																																																																																																																				
<table border="1" style="width: 100%; border-collapse: collapse;"> <thead> <tr> <th colspan="3">220-230V Models</th> <th colspan="3">380-480V Models</th> </tr> <tr> <th>IN</th> <th>P295</th> <th>Size</th> <th>IN</th> <th>P295</th> <th>Size</th> </tr> </thead> <tbody> <tr><td>6A</td><td>3</td><td rowspan="4">1</td><td>3,6A</td><td>0</td><td rowspan="4">1</td></tr> <tr><td>7A</td><td>4</td><td>4A</td><td>1</td></tr> <tr><td>10A</td><td>6</td><td>5,5A</td><td>2</td></tr> <tr><td>13A</td><td>7</td><td>9A</td><td>5</td></tr> <tr><td>16A</td><td>8</td><td rowspan="2">2</td><td>13A</td><td>7</td><td rowspan="2">2</td></tr> <tr><td>24A</td><td>9</td><td>16A</td><td>8</td></tr> <tr><td>28A</td><td>10</td><td rowspan="2">3</td><td>24A</td><td>9</td><td rowspan="2">3</td></tr> <tr><td>45A</td><td>13</td><td>30A</td><td>11</td></tr> <tr><td>54A</td><td>14</td><td rowspan="2">4</td><td>38A</td><td>12</td><td rowspan="2">4</td></tr> <tr><td>70A</td><td>16</td><td>45A</td><td>13</td></tr> <tr><td>86A</td><td>17</td><td rowspan="2">5</td><td>60A</td><td>15</td><td rowspan="2">5</td></tr> <tr><td>105A</td><td>18</td><td>70A</td><td>16</td></tr> <tr><td>130A</td><td>19</td><td>6</td><td>86A</td><td>17</td><td>6</td></tr> <tr><td></td><td></td><td></td><td>105A</td><td>18</td><td></td></tr> <tr><td></td><td></td><td></td><td>142A</td><td>20</td><td>7</td></tr> <tr><td></td><td></td><td></td><td>180A</td><td>21</td><td></td></tr> <tr><td></td><td></td><td></td><td>211A</td><td>55</td><td>8</td></tr> <tr><td></td><td></td><td></td><td>240A</td><td>22</td><td></td></tr> <tr><td></td><td></td><td></td><td>312A</td><td>67</td><td>9</td></tr> <tr><td></td><td></td><td></td><td>361A</td><td>23</td><td></td></tr> <tr><td></td><td></td><td></td><td>450A</td><td>24</td><td rowspan="2">10</td></tr> <tr><td></td><td></td><td></td><td>515A</td><td>69</td></tr> <tr><td></td><td></td><td></td><td>600A</td><td>25</td><td rowspan="2">above 500HP</td></tr> <tr><td></td><td></td><td></td><td>686A</td><td>33</td></tr> <tr><td></td><td></td><td></td><td>855A</td><td>34</td><td></td></tr> <tr><td></td><td></td><td></td><td>1140A</td><td>35</td><td></td></tr> <tr><td></td><td></td><td></td><td>1283A</td><td>36</td><td></td></tr> <tr><td></td><td></td><td></td><td>1710A</td><td>37</td><td></td></tr> </tbody> </table>			220-230V Models			380-480V Models			IN	P295	Size	IN	P295	Size	6A	3	1	3,6A	0	1	7A	4	4A	1	10A	6	5,5A	2	13A	7	9A	5	16A	8	2	13A	7	2	24A	9	16A	8	28A	10	3	24A	9	3	45A	13	30A	11	54A	14	4	38A	12	4	70A	16	45A	13	86A	17	5	60A	15	5	105A	18	70A	16	130A	19	6	86A	17	6				105A	18					142A	20	7				180A	21					211A	55	8				240A	22					312A	67	9				361A	23					450A	24	10				515A	69				600A	25	above 500HP				686A	33				855A	34					1140A	35					1283A	36					1710A	37	
220-230V Models			380-480V Models																																																																																																																																																																			
IN	P295	Size	IN	P295	Size																																																																																																																																																																	
6A	3	1	3,6A	0	1																																																																																																																																																																	
7A	4		4A	1																																																																																																																																																																		
10A	6		5,5A	2																																																																																																																																																																		
13A	7		9A	5																																																																																																																																																																		
16A	8	2	13A	7	2																																																																																																																																																																	
24A	9		16A	8																																																																																																																																																																		
28A	10	3	24A	9	3																																																																																																																																																																	
45A	13		30A	11																																																																																																																																																																		
54A	14	4	38A	12	4																																																																																																																																																																	
70A	16		45A	13																																																																																																																																																																		
86A	17	5	60A	15	5																																																																																																																																																																	
105A	18		70A	16																																																																																																																																																																		
130A	19	6	86A	17	6																																																																																																																																																																	
			105A	18																																																																																																																																																																		
			142A	20	7																																																																																																																																																																	
			180A	21																																																																																																																																																																		
			211A	55	8																																																																																																																																																																	
			240A	22																																																																																																																																																																		
			312A	67	9																																																																																																																																																																	
			361A	23																																																																																																																																																																		
			450A	24	10																																																																																																																																																																	
			515A	69																																																																																																																																																																		
			600A	25	above 500HP																																																																																																																																																																	
			686A	33																																																																																																																																																																		
			855A	34																																																																																																																																																																		
			1140A	35																																																																																																																																																																		
			1283A	36																																																																																																																																																																		
			1710A	37																																																																																																																																																																		
<table border="1" style="width: 100%; border-collapse: collapse;"> <thead> <tr> <th colspan="3">500-600V Models</th> <th colspan="3">500-690V Models</th> </tr> <tr> <th>IN</th> <th>P295</th> <th>Size</th> <th>IN</th> <th>P295</th> <th>Size</th> </tr> </thead> <tbody> <tr><td>2,9A</td><td>39</td><td rowspan="4">2</td><td>107A</td><td>51</td><td rowspan="3">8E</td></tr> <tr><td>4,2A</td><td>40</td><td>147A</td><td>53</td></tr> <tr><td>7A</td><td>4</td><td>211A</td><td>55</td></tr> <tr><td>10A</td><td>6</td><td>247A</td><td>57</td></tr> <tr><td>12A</td><td>41</td><td rowspan="2">4</td><td>315A</td><td>60</td><td rowspan="4">10E</td></tr> <tr><td>14A</td><td>42</td><td>343A</td><td>62</td></tr> <tr><td>22A</td><td>43</td><td rowspan="2">7</td><td>418A</td><td>63</td><td rowspan="2">10E</td></tr> <tr><td>27A</td><td>44</td><td>472A</td><td>65</td></tr> <tr><td>32A</td><td>45</td><td rowspan="2">7</td><td></td><td></td><td></td></tr> <tr><td>44A</td><td>46</td><td></td><td></td><td></td></tr> <tr><td>53A</td><td>47</td><td rowspan="2">7</td><td></td><td></td><td></td></tr> <tr><td>63A</td><td>48</td><td></td><td></td><td></td></tr> <tr><td>79A</td><td>49</td><td rowspan="2">7</td><td></td><td></td><td></td></tr> <tr><td>600A</td><td>25</td><td>above 500HP</td><td></td><td></td><td></td></tr> <tr><td>652A</td><td>72</td><td rowspan="2">above 500HP</td><td></td><td></td><td></td></tr> <tr><td>794A</td><td>73</td><td></td><td></td><td></td><td></td></tr> <tr><td>897A</td><td>76</td><td rowspan="2">above 500HP</td><td></td><td></td><td></td></tr> <tr><td>978A</td><td>78</td><td></td><td></td><td></td><td></td></tr> <tr><td>1191A</td><td>79</td><td rowspan="2">above 500HP</td><td></td><td></td><td></td></tr> <tr><td>1345A</td><td>81</td><td></td><td></td><td></td><td></td></tr> </tbody> </table>			500-600V Models			500-690V Models			IN	P295	Size	IN	P295	Size	2,9A	39	2	107A	51	8E	4,2A	40	147A	53	7A	4	211A	55	10A	6	247A	57	12A	41	4	315A	60	10E	14A	42	343A	62	22A	43	7	418A	63	10E	27A	44	472A	65	32A	45	7				44A	46				53A	47	7				63A	48				79A	49	7				600A	25	above 500HP				652A	72	above 500HP				794A	73					897A	76	above 500HP				978A	78					1191A	79	above 500HP				1345A	81																																																
500-600V Models			500-690V Models																																																																																																																																																																			
IN	P295	Size	IN	P295	Size																																																																																																																																																																	
2,9A	39	2	107A	51	8E																																																																																																																																																																	
4,2A	40		147A	53																																																																																																																																																																		
7A	4		211A	55																																																																																																																																																																		
10A	6		247A	57																																																																																																																																																																		
12A	41	4	315A	60	10E																																																																																																																																																																	
14A	42		343A	62																																																																																																																																																																		
22A	43	7	418A	63		10E																																																																																																																																																																
27A	44		472A	65																																																																																																																																																																		
32A	45	7																																																																																																																																																																				
44A	46																																																																																																																																																																					
53A	47	7																																																																																																																																																																				
63A	48																																																																																																																																																																					
79A	49	7																																																																																																																																																																				
600A	25		above 500HP																																																																																																																																																																			
652A	72	above 500HP																																																																																																																																																																				
794A	73																																																																																																																																																																					
897A	76	above 500HP																																																																																																																																																																				
978A	78																																																																																																																																																																					
1191A	79	above 500HP																																																																																																																																																																				
1345A	81																																																																																																																																																																					
<table border="1" style="width: 100%; border-collapse: collapse;"> <thead> <tr> <th colspan="3">660-690V Models</th> <th colspan="3">Special Models</th> </tr> <tr> <th>IN</th> <th>P295</th> <th>Size</th> <th>IN</th> <th>P295</th> <th></th> </tr> </thead> <tbody> <tr><td>100A</td><td>50</td><td rowspan="3">8E</td><td>2 A</td><td>38</td><td></td></tr> <tr><td>127A</td><td>52</td><td>33 A</td><td>66</td><td></td></tr> <tr><td>179A</td><td>54</td><td>200 A</td><td>26</td><td></td></tr> <tr><td>225A</td><td>56</td><td rowspan="4">10E</td><td>230 A</td><td>27</td><td></td></tr> <tr><td>259A</td><td>58</td><td>320 A</td><td>28</td><td></td></tr> <tr><td>305A</td><td>59</td><td>400 A</td><td>29</td><td></td></tr> <tr><td>340A</td><td>61</td><td>570 A</td><td>30</td><td></td></tr> <tr><td>428A</td><td>64</td><td rowspan="2">above 500HP</td><td>700 A</td><td>31</td><td></td></tr> <tr><td>492 A</td><td>68</td><td>900 A</td><td>32</td><td></td></tr> <tr><td>580 A</td><td>70</td><td rowspan="2">above 500HP</td><td></td><td></td><td></td></tr> <tr><td>646 A</td><td>71</td><td></td><td></td><td></td><td></td></tr> <tr><td>813 A</td><td>74</td><td rowspan="2">above 500HP</td><td></td><td></td><td></td></tr> <tr><td>869 A</td><td>75</td><td></td><td></td><td></td><td></td></tr> <tr><td>969 A</td><td>77</td><td rowspan="2">above 500HP</td><td></td><td></td><td></td></tr> <tr><td>1220A</td><td>80</td><td></td><td></td><td></td><td></td></tr> </tbody> </table>			660-690V Models			Special Models			IN	P295	Size	IN	P295		100A	50	8E	2 A	38		127A	52	33 A	66		179A	54	200 A	26		225A	56	10E	230 A	27		259A	58	320 A	28		305A	59	400 A	29		340A	61	570 A	30		428A	64	above 500HP	700 A	31		492 A	68	900 A	32		580 A	70	above 500HP				646 A	71					813 A	74	above 500HP				869 A	75					969 A	77	above 500HP				1220A	80																																																																								
660-690V Models			Special Models																																																																																																																																																																			
IN	P295	Size	IN	P295																																																																																																																																																																		
100A	50	8E	2 A	38																																																																																																																																																																		
127A	52		33 A	66																																																																																																																																																																		
179A	54		200 A	26																																																																																																																																																																		
225A	56	10E	230 A	27																																																																																																																																																																		
259A	58		320 A	28																																																																																																																																																																		
305A	59		400 A	29																																																																																																																																																																		
340A	61		570 A	30																																																																																																																																																																		
428A	64	above 500HP	700 A	31																																																																																																																																																																		
492 A	68		900 A	32																																																																																																																																																																		
580 A	70	above 500HP																																																																																																																																																																				
646 A	71																																																																																																																																																																					
813 A	74	above 500HP																																																																																																																																																																				
869 A	75																																																																																																																																																																					
969 A	77	above 500HP																																																																																																																																																																				
1220A	80																																																																																																																																																																					

Table 6.44 - Inverter Rated current selection

Parameter	Range [Factory Setting] Unit	Description / Notes																				
<b>P296</b> <sup>(1)</sup> <sup>(11)</sup> Inverter Rated Voltage (Rated Input Voltage)	0 to 8 [ 0 for models 220-230V 3 for models 380-480V 6 for models 500-600V and 500-690V 8 for models 600-690V ] -	<table border="1"> <thead> <tr> <th>P296</th> <th>Inverter Rated Voltage</th> </tr> </thead> <tbody> <tr><td>0</td><td>220V/230V</td></tr> <tr><td>1</td><td>380V</td></tr> <tr><td>2</td><td>400V/415V</td></tr> <tr><td>3</td><td>440V/460V</td></tr> <tr><td>4</td><td>480V</td></tr> <tr><td>5</td><td>500V/525V</td></tr> <tr><td>6</td><td>550V/575V</td></tr> <tr><td>7</td><td>600V</td></tr> <tr><td>8</td><td>660V/690V</td></tr> </tbody> </table>	P296	Inverter Rated Voltage	0	220V/230V	1	380V	2	400V/415V	3	440V/460V	4	480V	5	500V/525V	6	550V/575V	7	600V	8	660V/690V
		P296	Inverter Rated Voltage																			
		0	220V/230V																			
		1	380V																			
		2	400V/415V																			
		3	440V/460V																			
		4	480V																			
		5	500V/525V																			
		6	550V/575V																			
		7	600V																			
8	660V/690V																					
<b>Table 6.45 - Inverter Rated voltage selection</b>																						
 <b>ATTENTION!</b>																						
<ul style="list-style-type: none"> <li><input checked="" type="checkbox"/> Set P296 according to the rated AC line voltage! Do not set according to short term peak values.</li> <li><input checked="" type="checkbox"/> For CFW-09 models <math>\geq 86A/380-480V</math>, <math>\geq 44A/500-600V</math> and 500-690V models, also adjust the voltage selection jumper (Refer to Section 3.2.3).</li> </ul>																						

<b>P297</b> <sup>(1)</sup> <sup>(2)</sup> Switching Frequency	0 to 3 [ 2 (5.0 kHz) ] -	<table border="1"> <thead> <tr> <th>P297</th> <th>Switching Frequency</th> </tr> </thead> <tbody> <tr><td>0</td><td>1.25 kHz</td></tr> <tr><td>1</td><td>2.5 kHz</td></tr> <tr><td>2</td><td>5.0 kHz</td></tr> <tr><td>3</td><td>10.0 kHz</td></tr> </tbody> </table>	P297	Switching Frequency	0	1.25 kHz	1	2.5 kHz	2	5.0 kHz	3	10.0 kHz
		P297	Switching Frequency									
0	1.25 kHz											
1	2.5 kHz											
2	5.0 kHz											
3	10.0 kHz											
<b>Table 6.46 - Switching frequency selection</b>												
<ul style="list-style-type: none"> <li><input checked="" type="checkbox"/> The rated switching frequency for each model is shown in item 9.1. When a higher switching frequency is used, it is necessary to derate the output current as specified in item 9.1 note 3.</li> <li><input checked="" type="checkbox"/> Note that the switching frequency must be reduced from 5kHz to 2.5kHz when the VT rated current is used in the following models: from 54A to 130A/220-230V, from 30A to 142A/380-480V and 63A/500-600V.</li> <li><input checked="" type="checkbox"/> Note that the following models have a rated switching frequency of 2.5kHz: from 180A to 600A/380-480V, 44A and 79A/500-600V, from 107A to 472A/500-690V and all 660-690V models.</li> <li><input checked="" type="checkbox"/> The switching frequency is a compromise between the motor acoustic noise level and the inverter IGBTs losses. Higher switching frequencies cause lower motor acoustic noise level, but increase the IGBTs losses, increasing drive components temperature, thus reducing their useful life.</li> <li><input checked="" type="checkbox"/> The predominant frequency on the motor is twice the switching frequency programmed at P297.                       P297 = 5.0 kHz results in an audible motor noise corresponding to 10.0kHz. This is due to the PWM technique used.                       A reduction of the switching frequency also:                     <ul style="list-style-type: none"> <li>- Helps reducing instability and resonance problems that may occur in certain application conditions.</li> <li>- Reduces the leakage currents to ground, which may avoid nuisance E11 (Output Ground Fault).</li> </ul> </li> </ul>												

Parameter	Range [Factory Setting] Unit	Description / Notes
		<ul style="list-style-type: none"> <li>☑ The option 1.25kHz is not valid for the Vector Control (P202=3 or 4).</li> <li>☑ The option 10kHz is not valid for the Sensorless Vector Control (P202=3) and for the models with supply voltage between 500V and 690V (2.9A to 79A/500-600V, 107A to 472A/500-690V and 100A to 428A/660-690V).</li> </ul>

**P300**  
DC Braking Time

**This parameter is shown on the display(s) only when P202 = 0,1, 2, 3 or 5**

0.0 to 15.0  
[ 0.0 ]  
0.1s

- ☑ The DC braking feature provides a motor fast stop through the injection of DC current.
- ☑ This parameter sets the DC Braking Time when the drive is operating in the V/F, VVW or Sensorless Vector control modes.

Control Mode	DC Braking at Start	DC Braking at Stop
V/Hz	-	P300, P301 and P302
VVW	P302 and P371	P300, P301 and P302
Vector Sensorless	P371 and P372	P300, P301 and P372

Table 6.47 - Parameters related to the DC Braking

- ☑ Figure 6.40 shows the operation of the DC Braking with a ramp to stop (stop command). Refer to P301:

a) V/F Control

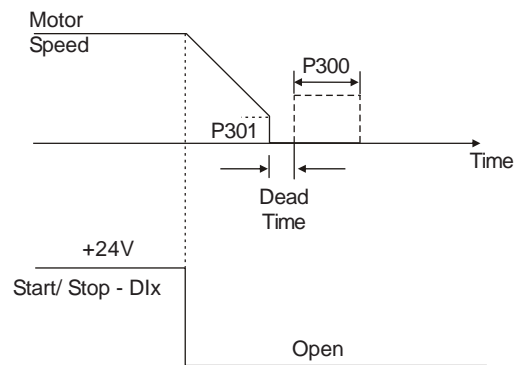

b) VVW and Sensorless Control

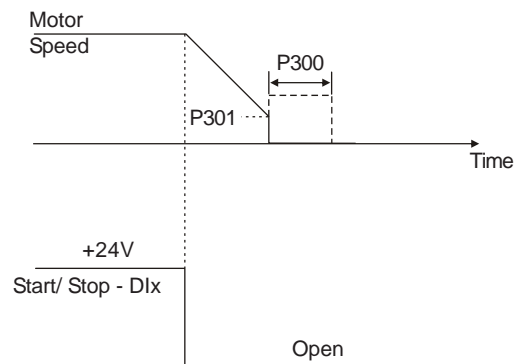

Figure 6.40 a) b) - DC Braking operation with a Ramp to Stop

Parameter	Range [Factory Setting] Unit	Description / Notes
-----------	------------------------------------	---------------------

- ☑ Figure 6.41 shows the operation of the DC Braking with a coast to stop (general disable command).  
This condition is valid only for the V/F control.

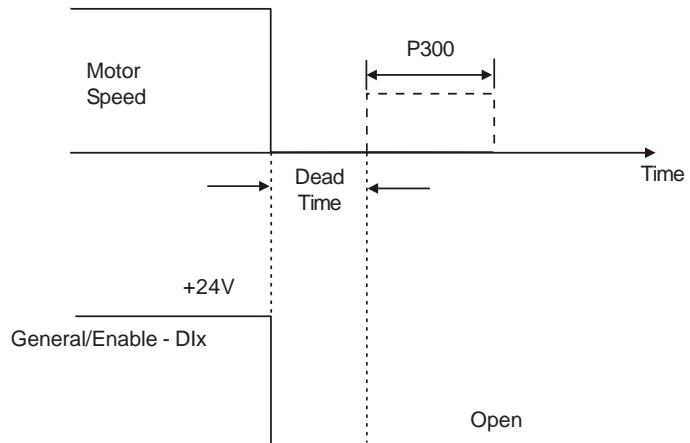

Figure 6.41 - DC braking operation with a general disable command in the V/F control

- ☑ For the V/F control, there is a “Dead Time” (motor runs freely) before the DC braking starts. This time is required in order to demagnetize the motor and it is a function of the motor speed.
- ☑ During the DC Braking the LED displays flashes `dCbr`.
- ☑ The DC braking does not work with P202 = 4 (Vector with encoder control).
- ☑ If the drive is enabled during the DC braking operation, the braking process is interrupted and the drive will return to its normal operation.



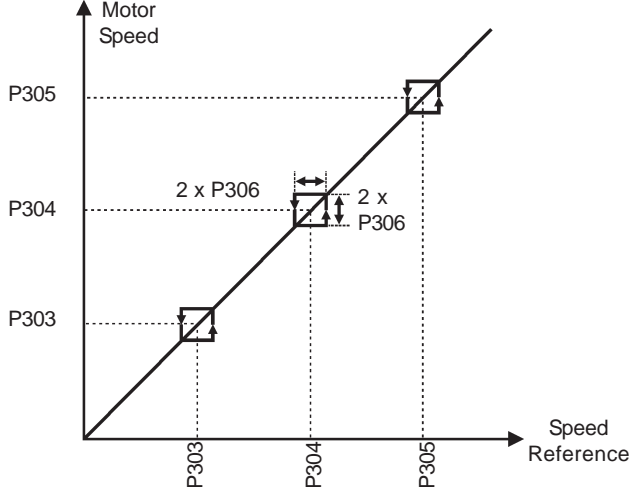

**ATTENTION!**

The DC braking may continue working even after the motor has already stopped. Pay special attention to the motor thermal sizing for cyclic braking of short time.

Parameter	Range [Factory Setting] Unit	Description / Notes
<b>P301</b> DC Braking Starting Speed  This parameter is shown on the display(s) only when P202 = 0,1, 2, 3 or 5	0 to 450 [ 30 ] 1 rpm	<input checked="" type="checkbox"/> This parameter establishes the starting point from where the DC Braking takes place. See figure 6.40.
<b>P302</b> DC Braking Voltage  This parameter is shown on the display(s) only when P202 = 0,1, 2, 3 or 5	0.0 to 10.0 [ 2.0 ] 0.1 %	<input checked="" type="checkbox"/> This parameter adjusts the DC voltage (DC braking torque) applied to the motor during the braking process.  <input checked="" type="checkbox"/> The setting shall be done by gradually increasing the value of P302, which varies from 0 to 10% of the rated supply voltage, until the desired braking torque is reached.  <input checked="" type="checkbox"/> This parameter works only for the V/F and VVW control modes. For the sensorless mode, refer to parameter P372.
<b>P303</b> Skip Speed 1  <b>P304</b> Skip Speed 2  <b>P305</b> Skip Speed 3  <b>P306</b> Skip Band Range	P133 to P134 [ 600 ] 1rpm  P133 to P134 [ 900 ] 1rpm  P133 to P134 [ 1200 ] 1rpm  0 to 750 [ 0 ] 1rpm	 <p>The graph illustrates the motor speed response during skip speed events. The x-axis represents the Speed Reference and the y-axis represents the Motor Speed. A diagonal line shows the normal linear speed increase. At three specific reference speeds (P303, P304, and P305), the motor speed remains constant for a duration, forming a 'skip band'. The width of each skip band is defined as 2 x P306. The motor speed resumes its linear increase after each skip band.</p> <input checked="" type="checkbox"/> This feature prevents the motor from operating permanently at speeds where the mechanical system enters into resonance, causing high vibration or noise levels.  <input checked="" type="checkbox"/> The passage through the skip speed band (2xP306) is made at the programmed acceleration/deceleration rates.  <input checked="" type="checkbox"/> This Function does not operate properly when two skip speeds are overlapped.
<b>P308</b> <sup>(1)</sup> Serial Address	1 to 30 [ 1 ] -	<input checked="" type="checkbox"/> Sets the address of the inverter for the serial communication. See item 8.13.

Parameter	Range [Factory Setting] Unit	Description / Notes																						
<b>P309</b> <sup>(1)</sup> Fieldbus	0 to 6 [ 0 ] -	<p><input checked="" type="checkbox"/> Defines the Fieldbus standard to be used (Profibus DP or Device NET) or the number of variables to be exchanged with the master. See item 8.12.5.</p> <table border="1" data-bbox="841 436 1182 646"> <thead> <tr> <th>P309</th> <th>Fieldbus Options</th> </tr> </thead> <tbody> <tr> <td>0</td> <td>Inactive</td> </tr> <tr> <td>1</td> <td>Profibus DP 2 I/O</td> </tr> <tr> <td>2</td> <td>Profibus DP 4 I/O</td> </tr> <tr> <td>3</td> <td>Profibus DP 6 I/O</td> </tr> <tr> <td>4</td> <td>DeviceNet 2 I/O</td> </tr> <tr> <td>5</td> <td>DeviceNet 4 I/O</td> </tr> <tr> <td>6</td> <td>DeviceNet 6 I/O</td> </tr> </tbody> </table> <p style="text-align: center;"><b>Table 6.48 - Fieldbus Options</b></p> <p><input checked="" type="checkbox"/> It is applicable only for the Profibus-DP kit (optional) or DeviceNet kit (optional).</p>	P309	Fieldbus Options	0	Inactive	1	Profibus DP 2 I/O	2	Profibus DP 4 I/O	3	Profibus DP 6 I/O	4	DeviceNet 2 I/O	5	DeviceNet 4 I/O	6	DeviceNet 6 I/O						
P309	Fieldbus Options																							
0	Inactive																							
1	Profibus DP 2 I/O																							
2	Profibus DP 4 I/O																							
3	Profibus DP 6 I/O																							
4	DeviceNet 2 I/O																							
5	DeviceNet 4 I/O																							
6	DeviceNet 6 I/O																							
<b>P310</b> <sup>(1)</sup> STOP detection in a Profibus network	0,1 [ 0 ] -	<p><input checked="" type="checkbox"/> This parameter allows programming the bit #6 of the Fieldbus control word (refer to item 8.12.5.2 - Variable Written in the Inverter).</p> <table border="1" data-bbox="699 974 1357 1251"> <thead> <tr> <th>P310</th> <th>Function</th> <th>Bit #6</th> <th>CFW09 Action</th> </tr> </thead> <tbody> <tr> <td>0</td> <td>Off</td> <td>No function</td> <td>-</td> </tr> <tr> <td rowspan="2">1</td> <td rowspan="2">On</td> <td>If bit6 = 0</td> <td>Executes a General Disable command, regardless of the value of the remaining bits of the control word.</td> </tr> <tr> <td>If bit6 = 1</td> <td>Executes the commands that were programmed at the remaining bits of the control word.</td> </tr> </tbody> </table> <p style="text-align: center;"><b>Table 6.49 - STOP detection in a Profibus network.</b></p> <p><input checked="" type="checkbox"/> If this parameter is set to ON, the bit #6 of the control word shall be kept in 1 to the drive operation. It will allow the drive to be disabled in case of STOP in the master of the Fieldbus network, where the control word is reset (all bits are set to zero).</p>	P310	Function	Bit #6	CFW09 Action	0	Off	No function	-	1	On	If bit6 = 0	Executes a General Disable command, regardless of the value of the remaining bits of the control word.	If bit6 = 1	Executes the commands that were programmed at the remaining bits of the control word.								
P310	Function	Bit #6	CFW09 Action																					
0	Off	No function	-																					
1	On	If bit6 = 0	Executes a General Disable command, regardless of the value of the remaining bits of the control word.																					
		If bit6 = 1	Executes the commands that were programmed at the remaining bits of the control word.																					
<b>P312</b> Type of Serial Protocol	0 to 9 [ 0 ] -	<table border="1" data-bbox="717 1507 1349 1860"> <thead> <tr> <th>P312</th> <th>Type of Serial Protocol</th> </tr> </thead> <tbody> <tr> <td>0</td> <td>WBUS Protocol</td> </tr> <tr> <td>1</td> <td>Modbus-RTU, 9600 bps, no parity</td> </tr> <tr> <td>2</td> <td>Modbus-RTU, 9600 bps, odd parity</td> </tr> <tr> <td>3</td> <td>Modbus-RTU, 9600 bps, even parity</td> </tr> <tr> <td>4</td> <td>Modbus-RTU, 19200 bps, no parity</td> </tr> <tr> <td>5</td> <td>Modbus-RTU, 19200 bps, odd parity</td> </tr> <tr> <td>6</td> <td>Modbus-RTU, 19200 bps, even parity</td> </tr> <tr> <td>7</td> <td>Modbus-RTU, 38400 bps, no parity</td> </tr> <tr> <td>8</td> <td>Modbus-RTU, 38400 bps, odd parity</td> </tr> <tr> <td>9</td> <td>Modbus-RTU, 38400 bps, even parity</td> </tr> </tbody> </table> <p style="text-align: center;"><b>Table 6.50 - Type of Serial Protocol</b></p> <p><input checked="" type="checkbox"/> It defines the protocol type used for the serial communication.</p>	P312	Type of Serial Protocol	0	WBUS Protocol	1	Modbus-RTU, 9600 bps, no parity	2	Modbus-RTU, 9600 bps, odd parity	3	Modbus-RTU, 9600 bps, even parity	4	Modbus-RTU, 19200 bps, no parity	5	Modbus-RTU, 19200 bps, odd parity	6	Modbus-RTU, 19200 bps, even parity	7	Modbus-RTU, 38400 bps, no parity	8	Modbus-RTU, 38400 bps, odd parity	9	Modbus-RTU, 38400 bps, even parity
P312	Type of Serial Protocol																							
0	WBUS Protocol																							
1	Modbus-RTU, 9600 bps, no parity																							
2	Modbus-RTU, 9600 bps, odd parity																							
3	Modbus-RTU, 9600 bps, even parity																							
4	Modbus-RTU, 19200 bps, no parity																							
5	Modbus-RTU, 19200 bps, odd parity																							
6	Modbus-RTU, 19200 bps, even parity																							
7	Modbus-RTU, 38400 bps, no parity																							
8	Modbus-RTU, 38400 bps, odd parity																							
9	Modbus-RTU, 38400 bps, even parity																							

Parameter	Range [Factory Setting] Unit	Description / Notes												
<b>P313</b> Disabling with E28/E29/E30	0 to 4 [ 0 ] -	<table border="1"> <thead> <tr> <th>P313</th> <th>Disabling with E28/E29/E30</th> </tr> </thead> <tbody> <tr> <td>0</td> <td>Disable via Start/Stop</td> </tr> <tr> <td>1</td> <td>Disable via General Enable</td> </tr> <tr> <td>2</td> <td>No Action</td> </tr> <tr> <td>3</td> <td>Changes to LOCAL 1</td> </tr> <tr> <td>4</td> <td>Changes to LOCAL 2 - Keeping the commands and the reference</td> </tr> </tbody> </table> <p style="text-align: center;"><b>Table 6.51 - Disabling with E28/E29/E30</b></p> <ul style="list-style-type: none"> <li><input checked="" type="checkbox"/> Defines the inverter behavior when the serial communication is inactive (causing error E28), when physical connection with the master of the Fieldbus is interrupted (causing error E29) or when the Fieldbus board is inactive (causing error E30). See item 8.12.5.</li> <li><input checked="" type="checkbox"/> For P313 = 4, when the drive detects a failure on the Fieldbus network and changes from Remote mode to Local mode, the ramp enable command and the speed reference received through the Fieldbus network will be maintained in the Local mode if the ramp enable command is being controlled in the Local mode through the 3-wire Start/Stop control or through the keypad.</li> </ul>	P313	Disabling with E28/E29/E30	0	Disable via Start/Stop	1	Disable via General Enable	2	No Action	3	Changes to LOCAL 1	4	Changes to LOCAL 2 - Keeping the commands and the reference
		P313	Disabling with E28/E29/E30											
0	Disable via Start/Stop													
1	Disable via General Enable													
2	No Action													
3	Changes to LOCAL 1													
4	Changes to LOCAL 2 - Keeping the commands and the reference													
<b>P314</b> <sup>(1)</sup> Time for Serial Watchdog Action	0.0 to 999.0s [ 0.0 ] -	<table border="1"> <thead> <tr> <th>P314</th> <th>Time for serial watchdog action</th> </tr> </thead> <tbody> <tr> <td>0.0</td> <td>Disable</td> </tr> <tr> <td>0.1 to 999.0</td> <td>Enable</td> </tr> </tbody> </table> <p style="text-align: center;"><b>Table 6.52 - Serial Watchdog Action</b></p> <ul style="list-style-type: none"> <li><input checked="" type="checkbox"/> If the inverter does not receive any valid serial telegram after the time programmed at P314 has elapsed, the Fault Message E28 on the HMI and the inverter will return to the action programmed at P313 - Type of Disabling by E28/E29/E30.</li> <li><input checked="" type="checkbox"/> To enable the inverter to execute this action, the inverter commands must be programmed to the "Serial" option at the parameters P220 to P228.</li> </ul>	P314	Time for serial watchdog action	0.0	Disable	0.1 to 999.0	Enable						
		P314	Time for serial watchdog action											
0.0	Disable													
0.1 to 999.0	Enable													
<b>P318</b> Watchdog detection for the PLC board	0,1 [ 1 ] -	<table border="1"> <thead> <tr> <th>P318</th> <th>Function</th> <th>Description</th> </tr> </thead> <tbody> <tr> <td>0</td> <td>Off</td> <td>Disables the activation of the Watchdog Error for the PLC board - E71.</td> </tr> <tr> <td>1</td> <td>On</td> <td>Enables the activation of the Watchdog Error for the PLC board - E71.</td> </tr> </tbody> </table> <p style="text-align: center;"><b>Table 6.53 - Watchdog detection for the PLC board</b></p>	P318	Function	Description	0	Off	Disables the activation of the Watchdog Error for the PLC board - E71.	1	On	Enables the activation of the Watchdog Error for the PLC board - E71.			
		P318	Function	Description										
0	Off	Disables the activation of the Watchdog Error for the PLC board - E71.												
1	On	Enables the activation of the Watchdog Error for the PLC board - E71.												

Parameter	Range [Factory Setting] Unit	Description / Notes										
<b>P320</b> <sup>(1)</sup> Flying Start/Ride-Through	0 to 3 [ 0 (Inactive) ] -	<p><input checked="" type="checkbox"/> The Parameter P320 selects the use of the following functions:</p> <table border="1"> <thead> <tr> <th>P320</th> <th>Function</th> </tr> </thead> <tbody> <tr> <td>0</td> <td>Inactive</td> </tr> <tr> <td>1</td> <td>Only Flying Start is active [valid for P202=0,1, 2 (V/F Control), 3 (sensorless) or 5 (VVW)]</td> </tr> <tr> <td>2</td> <td>Flying Start and Ride-Through are active [valid for P202=0,1, 2 (V/F Control), 3 (sensorless) or 5 (VVW)]</td> </tr> <tr> <td>3</td> <td>Only Ride-Through is active</td> </tr> </tbody> </table> <p style="text-align: center;"><i>Table 6.54 - Flying Start/Ride-Through</i></p>	P320	Function	0	Inactive	1	Only Flying Start is active [valid for P202=0,1, 2 (V/F Control), 3 (sensorless) or 5 (VVW)]	2	Flying Start and Ride-Through are active [valid for P202=0,1, 2 (V/F Control), 3 (sensorless) or 5 (VVW)]	3	Only Ride-Through is active
P320	Function											
0	Inactive											
1	Only Flying Start is active [valid for P202=0,1, 2 (V/F Control), 3 (sensorless) or 5 (VVW)]											
2	Flying Start and Ride-Through are active [valid for P202=0,1, 2 (V/F Control), 3 (sensorless) or 5 (VVW)]											
3	Only Ride-Through is active											
<b>P321</b> <sup>(6)</sup> Ud Line Loss Level	178 V to 282 V (P296=0) [252 V] 1V 307 V to 487 V (P296=1) [436 V] 1V 324 V to 513 V (P296=2) [459 V] 1V 356 V to 564 V (P296=3) [505V] 1V 388 V to 615 V (P296=4) [550V] 1V 425 V to 674 V (P296=5) [602V] 1V 466 V to 737 V (P296=6) [660V] 1V 486 V to 770 V (P296=7) [689V] 1V 559 V to 885 V (P296=8) [792V] 1V	<p><input checked="" type="checkbox"/> The activation of the Ride-Through function can be visualized at the outputs DO1, DO2, RL1, RL2 and/or RL3 (<b>P275, P276, P277, P279 and/or P280</b>) provided they are also programmed to “23=Ride-Through”;</p> <p> <b>NOTE!</b> When one of the functions, Ride-Through or Flying Start is activated, the parameter P214 (Line Phase Loss Detection) is automatically set to 0=Off.</p> <p> <b>NOTE!</b> This parameter works together with P321, P322, P323, P325, P326 for Ride-Through in Vector Control, and with P331, P332 for V/F Control Ride-Through and Flying-Start.</p> <p> <b>NOTE!</b> Ud=Vac x 1.35</p> <p><b><u>Ride-Through for Vector Control (P202=3 or 4)</u></b></p> <p><input checked="" type="checkbox"/> The purpose of the Ride-Through function, in Vector mode (P202 = 3 or 4), is to ensure that the inverter maintains the motor running during the line loss, not allowing interruption or fault storing. The energy required for motor running is obtained from the kinetic energy of the motor (inertia) during its deceleration. As soon as the line is reestablished, the motor accelerates again to the speed defined by the reference.</p> <p><input checked="" type="checkbox"/> After line loss (t0), the DC link voltage (Ud) starts to decrease in a rate that depends on the motor load condition and may reach the undervoltage level (t2), if the Ride-Through function is not operating. The time required for this condition, typical for rated load, situates in a range from 5 to 15 ms;</p> <p>With Ride-Through function active, the line loss is detected when Ud voltage becomes lower than the “Ud line loss” value (t1). The inverter immediately starts a controlled motor deceleration, regenerating the energy into the DC link and thus maintaining the motor running, where the Ud voltage is regulated to the “Ud Ride-Through” value.</p>										

 This parameter is shown on the display(s) only when P202 = 3 or 4 (Vector Control)







Parameter	Range [Factory Setting] Unit	Description / Notes
<b>P322</b> <sup>(6)</sup> Ud Ride-Through   <b>This parameter is shown on the display(s) only when P202 = 3 or 4 (Vector Control)</b>	178 V to 282 V (P296=0) [245 V] 1V 307 V to 487 V (P296=1) [423V] 1V 324 V to 513 V (P296=2) [446 V] 1V 356 V to 564 V (P296=3) [490 V] 1V 388 V to 615 V (P296=4) [535 V] 1V 425 V to 674 V (P296=5) [588V] 1V 466 V to 737 V (P296=6) [644V] 1V 486 V to 770 V (P296=7) [672V] 1V 559 V to 885 V (P296=8) [773V] 1V	<p><input checked="" type="checkbox"/> If the line loss is not recovered, the motor remains in this condition as long as possible (depending on the energy equilibrium), until the undervoltage condition (E02 at t5) occurs. If the line loss is recovered (t3) before the undervoltage condition, the inverter detects its reestablishment when the Ud voltage reaches the “Ud Loss Recover” level (t4). Then the motor is accelerated according to the set ramp, from the current speed value up to the value defined by the active speed reference. See figure 6.43.</p> <p>If the input voltage drops to a value between parameters P322 and P323, the values of P321, P322 and 323 shall be readjusted.</p> <p> <b>NOTE!</b>                      Cares with Application:                      The use of the line reactance or DC choke is mandatory to limit the inrush current when the network is reestablished.</p> <p> <b>NOTE!</b>                      The function Ride-Trough in Vector Mode for models 107A to 472A/ 500-690V and 100A to 428A/660-690V works only up to a maximum time of 2s. In these models the control power supply is not fed from the DC link, it is a separate power supply with 2s autonomy.</p> <p> <b>NOTE!</b>                      To activate the ride-though, the line supply must fall to a value lower than <math>(P321 \div 1.35)</math>.</p>
<b>P323</b> <sup>(6)</sup> Ud Loss Recover Level   <b>This parameter is shown on the display(s) only when P202 = 3 or 4 (Vector Control)</b>	178 V to 282 V (P296=0) [267 V] 1V 307 V to 487 V (P296=1) [461 V] 1V 324 V to 513 V (P296=2) [486 V] 1V	 <p>The graph illustrates the Ud voltage response during a ride-through event. Key time points include t0 (start of ride-through), t1 (end of ride-through), t2 (undervoltage condition), t3 (line loss recovery), t4 (Ud loss recover level), and t5 (undervoltage condition E02). The nominal Ud level is shown as a hatched area at the top of the graph.</p>

Figure 6.43 - Actuation of the Ride-Through function in Vector Control mode

Parameter	Range [Factory Setting] Unit	Description / Notes
	356 V to 564 V (P296=3) [534 V] 1V	<input checked="" type="checkbox"/> t0 - Line loss;
	388 V to 615 V (P296=4) [583 V] 1V	<input checked="" type="checkbox"/> t1 - Line loss detection;
	425 V to 674 V (P296=5) [638V] 1V	<input checked="" type="checkbox"/> t2 - Trip by Undervoltage (E02 without Ride-Through);
	466 V to 737 V (P296=6) [699V] 1V	<input checked="" type="checkbox"/> t3 - Line Recover;
	486 V to 770 V (P296=7) [729V] 1V	<input checked="" type="checkbox"/> t4 - Line Recover detection;
	559 V to 885 V (P296=8) [838V] 1V	<input checked="" type="checkbox"/> t5 - Trip by Undervoltage (E02 with Ride-Through);
<b>P325</b> Ride-Through Proportional Gain	0.0 to 63.9 [22.8] 0.1	 <p style="text-align: center;"><b>Figure 6.44 - Ride-Through PI Controller</b></p>
<b>P326</b> Ride-Through Integral Gain	0.000 to 9.999 [0.128] 0.001	<input checked="" type="checkbox"/> Normally the factory setting for P325/P326 is adequate for most applications.
<p><b>This parameter is shown on the display(s) only when P202 = 3 or 4 (Vector Control)</b></p> <p><b>This parameter is shown on the display(s) only when P202 = 3 or 4 (Vector Control)</b></p>		

Parameter	Range [Factory Setting] Unit	Description / Notes
P331 Voltage Ramp	0.2 to 60.0 [ 2.0 ] 0.1s	<ul style="list-style-type: none"> <li>☑ The Flying-start function allows the drive to start a motor that is running freely. This function takes the motor from its actual speed to the speed reference set at the drive.</li> </ul>
P332 Dead Time	0.0 to 10.0 [ 1.0 ] 0.1s	<ul style="list-style-type: none"> <li>☑ In order to enable the Flying Start function set P320 = 1 or 2.</li> <li>☑ If the Flying-Start function is not needed at some moments, a digital input may be set to disable the Flying-start (set only one of the parameters between P265 and P270 to 17).</li> </ul>

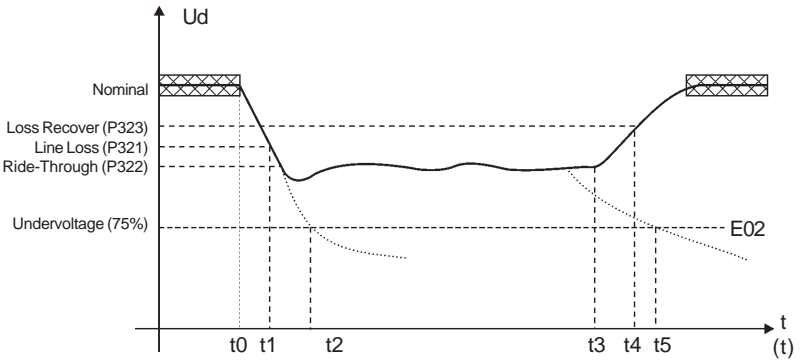
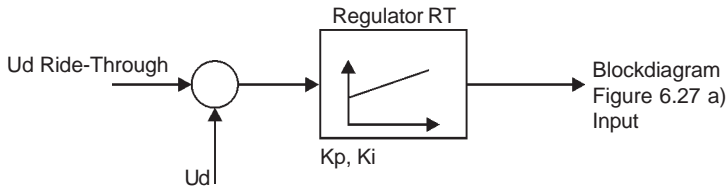
 These parameters ( P331 and P332) are only displayed when P202 = 0, 1, 2 or 5 (V/F / VVW Control)

**Flying Start for V/F control mode:**

- ☑ To do that it has a voltage ramp (adjusted in P331) and the motor frequency is fixed and defined by the speed setpoint. The Flying Start will always work when a start or run command is given, after the time adjusted in P332 (to allow for the motor demagnetization).
- ☑ Parameter P331 sets the time required for the output voltage reaching the rated voltage;

**Flying Start (FS) function for the sensorless vector control (P202=3)**

- ☑ The Flying-Start function takes place after the START command. At this moment, the drive senses the motor speed, and once the motor speed is found, which may be in the forward or reverse direction, the motor is accelerated to the speed reference indicated in P001.
- ☑ Parameters P135, P331 and P332 are not used by the Flying Start function when P202=3.

Settings:

- ☑ It is recommended to adjust P151 to the value in table 6.7 and P150 to 1.

**Ride-Through for V/F control mode or VVW:**

- ☑ The Ride-Through function for the V/F and VVW control modes works in a different manner than in the vector control mode. As soon as the line supply falls to a value lower than the undervoltage (E02) Trip level (see item 7.1), the IGBT inverter is disabled (no voltage pulses at the motor). There is no tripping due to undervoltage, and the DC link voltage will slowly fall until the line supply comes back.
- ☑ If the line supply takes too long to come back (more than 2s) the inverter may trip by E02 or E70. If it comes back before, the inverter will start the motor with a voltage ramp like in the Flying Start function, The voltage ramp time is defined also in P331. See figures 6.45 a) and b).
- ☑ The parameter P332, used for the Ride-Through function, sets the minimum time which the inverter will wait to restart the motor after voltage re-establishment. This time is computed from the line loss and is required for the motor demagnetization. Set this time at two times the motor rotor constant, see table in P412.
- ☑ The ride-through function allows recovering the drive without E02 trip (under voltage) during a momentary power supply interruption.

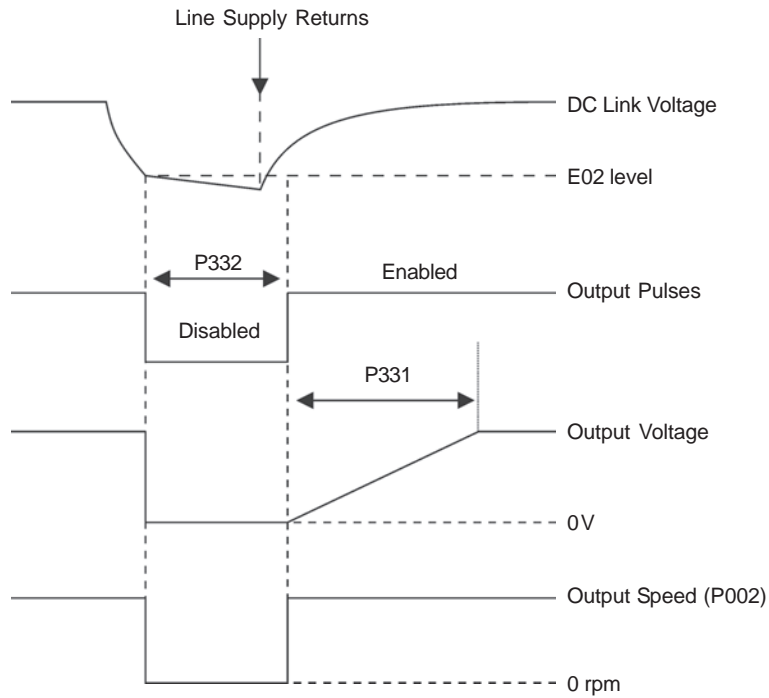

Figure 6.45 a) - Ride-Through actuation (Line returns before time set at P332 elapses) in V/F mode

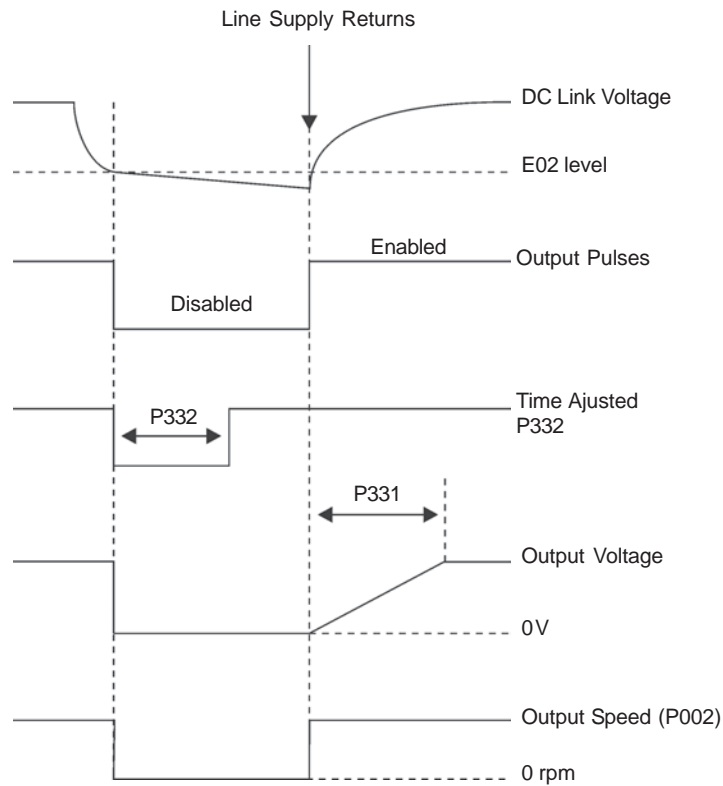















Figure 6.45 b) - Ride-Through actuation (Line returns after time set in P332, but before 2sec for  $P332 \leq 1\text{sec}$  or before  $2 \times P332$  for  $P332 > 1\text{sec}$ ) in V/F mode

6.3.1 Parameters for Crane Applications and for Torque Master/Slave Function - P351 to P368

Parameter	Range [Factory Setting] Unit	Description / Notes
<p><b>P351</b> <sup>(1)</sup> Delay for E33 Speed without control</p> <p> <b>This parameter is shown on the display(s) only when P202 = 3 or 4.</b></p>	<p>0.0 to 99.9 [ 99.9 ] 9</p>	<p><input checked="" type="checkbox"/> If the difference between N (Real Speed) and N* (Speed Reference) remains greater than the value set at parameter P292 for a period longer than that set at parameter P351 the drive will trip with an error code E33.</p> <p>99.9 = E33 is disabled</p>
<p><b>P352</b> <sup>(1)</sup> Delay for E34 Long Period at Torque Limitation</p> <p> <b>This parameter is shown on the display(s) only when P202 = 3 or 4.</b></p>	<p>0 to 999 [ 999 ] s</p>	<p><input checked="" type="checkbox"/> If the CFW-09 remains at torque limitation for a period longer than the value set at P352 the drive will trip with an error code E34.</p> <p>999 = E34 is disabled.</p> <p> <b>NOTE!</b> When the CFW-09 is used in “master/slave” applications, disable this function on the slave drive.</p>
<p><b>P353</b> <sup>(1)</sup> Delay for N&lt;Nx Brake Activation</p>	<p>0.0 a 20.0 [0.0] s</p>	<p><input checked="" type="checkbox"/> Defines the time to activate the brake, i.e., the time that elapses between the condition N&lt;Nx and the brake activation.</p>
<p><b>P354</b> <sup>(1)</sup> Delay for Resetting the Integrator of the Speed Regulator</p> <p> <b>This parameter is shown on the display(s) only when P202 = 4 (vector with encoder)</b></p>	<p>0.0 a 10.0 [2.0] s</p>	<p><input checked="" type="checkbox"/> This adjustment is needed to ensure that the motor current will be reduced after the brake activation.</p> <p> <b>ATTENTION!</b> If this value is lower than time needed to activate the mechanical braking, jerking, swinging or even falling may happen. If this value is greater than that set at P351 or P352, the drive may trip with an error code E33 or E34, respectively.</p>
<p><b>P355</b> <sup>(1)</sup> Delay for Accepting new “Start/Stop” commands</p>	<p>0.0 to 10.0 [1.0] s</p>	<p><input checked="" type="checkbox"/> This is the dead time that ensures the braking activation. Any other “Start/Stop” command is not accepted during this period.</p> <p><input checked="" type="checkbox"/> Defines the time that the CFW-09 waits before accepting a new “Start” command after the motor is stopped. During the period set at P355 the commands are ignored.</p>

Parameter	Range [Factory Setting] Unit	Description / Notes									
<b>P356</b> <sup>(1)</sup> Delay for ramp enable	0.0 to 10.0 [ 0.0 ] s	<ul style="list-style-type: none"> <li>☑ This is the time that the CFW-09 waits before enabling the ramp after receiving the “Start” command.</li> </ul>									
<b>P357</b> <sup>(1)</sup> Filter for the Torque Current -Iq	0.00 to 9.99 [0.00] s	<ul style="list-style-type: none"> <li>☑ Time constant of the filter applied to the torque current. The sampling time is 5ms.</li> <li>☑ It works along with P358 and activates a digital or relay output that was set to the option Torque Polarity +/-.</li> <li>☑ The filtered torque current may be available at analog outputs AO3 and AO4 when they are set to the option “Iq with P357” (P255 and/or P257 = 38).</li> </ul>									
<b>P358</b> <sup>(1)</sup> Hysteresis for the Torque Current - Iq	0.00 a 9.99 [2.00] %	<ul style="list-style-type: none"> <li>☑ Establishes the percentage of hysteresis that is applied to the commutation of a digital (DOx) or relay output when they are set to the options 34 or 35.</li> </ul> <div style="text-align: center;"> </div> <p style="text-align: center;"><b>Figure 6.46 - Hysteresis for the Torque Current - Iq</b></p>									
<b>P361</b> <sup>(1)</sup> Load Detector	0,1 [0] -	<table border="1" style="width: 100%; border-collapse: collapse;"> <thead> <tr> <th>P361</th> <th>Function</th> <th>Description</th> </tr> </thead> <tbody> <tr> <td style="text-align: center;">0</td> <td style="text-align: center;">Off</td> <td>Functions that are set at parameters from P362 to P368 are disabled.</td> </tr> <tr> <td style="text-align: center;">1</td> <td style="text-align: center;">On</td> <td>The following functions are enabled: Slack Cable Detection, Lightweight Level and Overweight Detection.</td> </tr> </tbody> </table> <p style="text-align: center;"><b>Table 6.55 - Detector de Carga</b></p> <p><b>NOTE!</b> Refer to figures 6.47 a) and b).</p>	P361	Function	Description	0	Off	Functions that are set at parameters from P362 to P368 are disabled.	1	On	The following functions are enabled: Slack Cable Detection, Lightweight Level and Overweight Detection.
P361	Function	Description									
0	Off	Functions that are set at parameters from P362 to P368 are disabled.									
1	On	The following functions are enabled: Slack Cable Detection, Lightweight Level and Overweight Detection.									
<b>P362</b> <sup>(1)</sup> Stabilization Speed	0 to P134 [90] rpm	<ul style="list-style-type: none"> <li>☑ The motor accelerates up to the stabilization speed and remains at this speed during the time set at parameter P363.</li> <li>☑ During this period, the CFW-09 detects the load condition by using the average current.</li> </ul>									

**Available only if P361 = 1 (On)**

Parameter	Range [Factory Setting] Unit	Description / Notes
<b>P363</b> <sup>(1)</sup> Stabilization Time   Available only if P361 = 1 (On)	0.1 to 10.0 [ 0.1 ] s	<input checked="" type="checkbox"/> Time that the CFW-09 waits before starting the load detection after the stabilization speed has been reached.
<b>P364</b> <sup>(1)</sup> Slack Cable Time   Available only if P361 = 1 (On)	0.0 to 60.0 [0.0] s	<input checked="" type="checkbox"/> Time that the CFW-09 waits to commutate the digital (DOx) and relay outputs set to the option "Slack Cable Detection". If the Slack Cable condition is no longer valid, the CFW-09 resets the digital or relay outputs.   <b>NOTE!</b> When P364=0, the detection logic of slack cable is disabled.
<b>P365</b> <sup>(1)</sup> Slack Cable Level   Available only if P361 = 1 (On)	0.0 to 1.3 x [0.1 x P295] A	<input checked="" type="checkbox"/> Output current value used to detect the slack cable condition.
<b>P366</b> <sup>(1)</sup> Light Load Level   Available only if P361 = 1 (On)	0.0 to 1.3 x P295 [0.3 x P401] A	<input checked="" type="checkbox"/> Output current value used to detect the light load condition. At the end of this process the speed reference is increased according to P368. The new speed value is $N=N* \times P368$ . This condition is reset when the motor remains stopped for 1 second.   <b>NOTE!</b> This condition is verified only during the stabilization time.
<b>P367</b> <sup>(1)</sup> Overweight Level   Available only if P361 = 1 (On)	0.0 to 1.8 x P295 [1.1 x P401] -	<input checked="" type="checkbox"/> Output current value used to detect the overweight condition. This function is only enabled during the stabilization time. This condition is reset when the motor remains stopped ( $N=0$ ) for 1 second.   <b>NOTE!</b> This condition is verified only during the stabilization time.
<b>P368</b> <sup>(1)</sup> Reference Gain   Available only if P361 = 1 (On)	1.000 to 2.000 [1.000] -	<input checked="" type="checkbox"/> This parameter increases the speed reference under the light load condition.
<b>P369</b> <sup>(2) (11)</sup> Frequency Fx	0.0 to 300 [4.0] 0.1 Hz	<input checked="" type="checkbox"/> It is used in functions of the digital and relay outputs: $F > Fx$

a) Activation of the load detection parameters during the stabilization time and with P361 = On

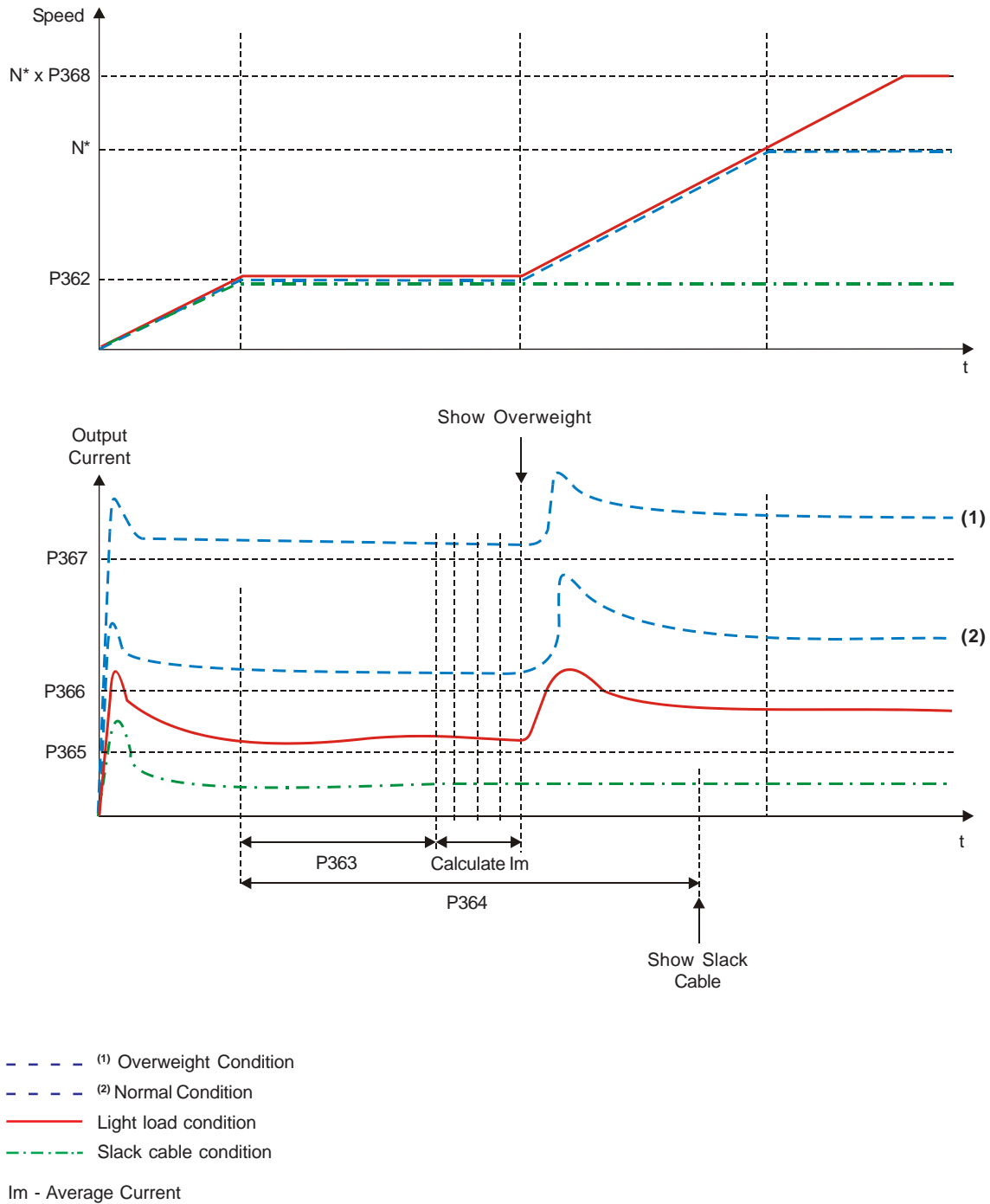
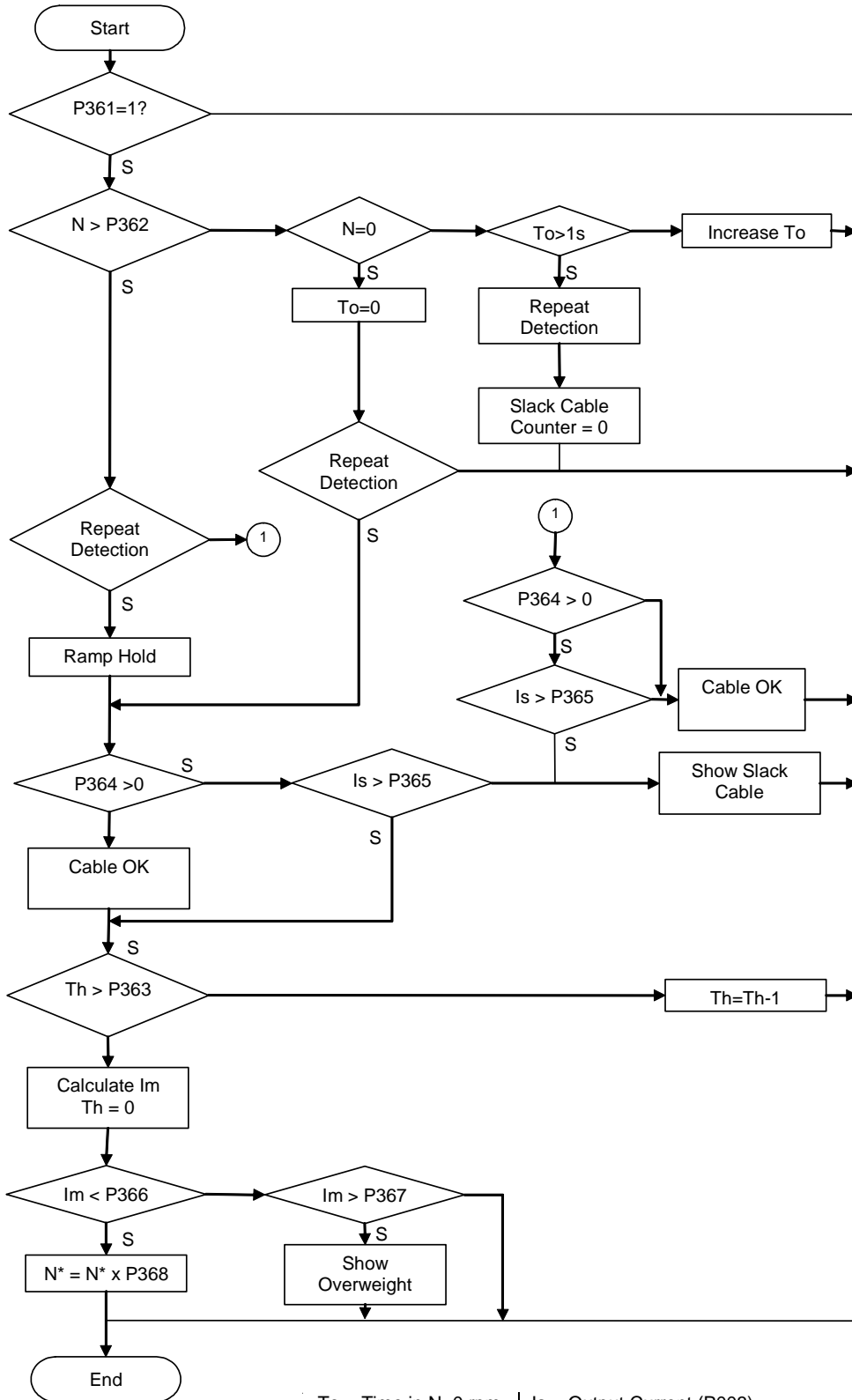







Figure 6.47 a) - Details of the operation of digital functions

b) Diagram of the Load Detection Logic



To = Time in N=0 rpm | Is = Output Current (P003)  
 Th = Ramp Hold Time | Im = Average Current  
 N\* = Speed Reference | Iq = Torque Current  
 N = Real Speed

Figure 6.47 b) - Details of the operation of digital functions

Parameter	Range [Factory Setting] Unit	Description / Notes						
<b>P370</b> Hysteresis for Fx	0.0 to 15.0 [2.0] 0.1 Hz	<ul style="list-style-type: none"> <li><input checked="" type="checkbox"/> It is used in functions of the digital and relay outputs: F &gt; Fx</li> </ul>						
<b>P371</b> DC Braking Time at Start  This parameter is shown on the display(s) only when P202=3 (Sensorless) or 5 (VWV)	0.0 to 15.0 [0.0] 0.1 s	<ul style="list-style-type: none"> <li><input checked="" type="checkbox"/> The DC braking at start consists of applying a DC current to the motor between the “Start” command and the motor acceleration.</li> <li><input checked="" type="checkbox"/> This parameter adjusts the DC braking time at start for the VWV and Sensorless Vector control modes</li> <li><input checked="" type="checkbox"/> If the drive is disabled during the DC braking operation, the braking process will continue until the braking time set at P371 finishes. After that the drive returns to the “RDY” state.</li> <li><input checked="" type="checkbox"/> The DC braking at start is not available for: <ul style="list-style-type: none"> <li>- The V/Hz and Vector with Encoder control modes;</li> <li>- Start commands through the serial and Fieldbus interfaces with P202=3;</li> <li>- When P211=1;</li> <li>- When the Flying Start function is set (P320&gt;=1)</li> </ul> </li> <li><input checked="" type="checkbox"/> The DC current level is set at P302 (VWV) and P372 (sensorless).</li> <li><input checked="" type="checkbox"/> During the DC Braking the LED displays flashes </li> </ul>						
<b>P372</b> DC Braking Current Level  This parameter is shown on the display(s) only when P202 = 3 (Sensorless)	0.0 to 90.0 [40.0] 0.1 %	<ul style="list-style-type: none"> <li><input checked="" type="checkbox"/> This parameter adjusts the DC voltage (DC braking torque) applied to the motor during the braking process.</li> <li><input checked="" type="checkbox"/> The current level set at this parameter represents a percentage of the drive rated current.</li> <li><input checked="" type="checkbox"/> This parameter works only for the sensorless vector control.</li> </ul>						
<b>P398</b> <sup>(1)</sup> Slip Compensation during Regeneration  This parameter is shown on the display(s) only when P202 = 5 (VWV)	0,1 [1] -	<table border="1" style="margin-left: auto; margin-right: auto;"> <thead> <tr> <th>P398</th> <th>Function</th> </tr> </thead> <tbody> <tr> <td>0</td> <td>Off</td> </tr> <tr> <td>1</td> <td>On</td> </tr> </tbody> </table> <p style="text-align: center;"><i>Table 6.56 - Slip Compensation during Regeneration</i></p>	P398	Function	0	Off	1	On
P398	Function							
0	Off							
1	On							
<b>P399</b> <sup>(1)(2)</sup> Rated Motor Efficiency  This parameter is shown on the display(s) only when P202 = 5 (VWV)	50.0 to 99. [-] %	<ul style="list-style-type: none"> <li><input checked="" type="checkbox"/> This parameter sets the motor rated efficiency;</li> <li><input checked="" type="checkbox"/> This parameter is important to the correct operation of the VWV control. The incorrect setting of this parameter results in the incorrect calculation of the slip compensation;</li> <li><input checked="" type="checkbox"/> The default value of this parameter is automatically set when parameter P404 is modified. The suggested value is valid only for IV pole standard three-phase WEG motors. The user shall set this parameter manually for other motor types.</li> </ul>						

6.4 MOTOR PARAMETERS - P400 to P499

Parameter	Range [Factory Setting] Unit	Description / Notes
<b>P400</b> <sup>(1)(6)</sup> Motor Rated Voltage	0 to 690 [ P296 ] 1V	<input checked="" type="checkbox"/> Set this parameter value according to the motor nameplate and the connection diagram in the terminal box. <input checked="" type="checkbox"/> This value cannot be greater than the rated voltage value set at P296. <input checked="" type="checkbox"/> In order to make a new setting of P400 effective while not in the guided start-up routine, it is necessary to power the drive down/up.
<b>P401</b> <sup>(1)(12)</sup> Motor Rated Current	0.0 to 1.30xP295 <sup>(12)</sup> [ 1.0 x P295 ] 0.1A(<100)-1A(>99.9)	<input checked="" type="checkbox"/> Set this parameter according to the motor nameplate, considering the motor operating voltage.
<b>P402</b> <sup>(1)(2)(11)</sup> Motor Rated Speed	0 to 18000 [ 1750 (1458) ] <sup>(11)</sup> 1rpm 0 to 7200 [ 1750 (1458) ] <sup>(11)</sup> 1rpm	<input checked="" type="checkbox"/> Set this parameter according to the motor nameplate. <input checked="" type="checkbox"/> 0 to 18000 rpm for V/F Control. <input checked="" type="checkbox"/> 0 to 7200 rpm for Vector Control.
<b>P403</b> <sup>(1)(11)</sup> Motor Rated Frequency	0 to 300 [ 60 (50) ] <sup>(11)</sup> 1Hz 30 to 120 [ 60 (50) ] <sup>(11)</sup> 1Hz	<input checked="" type="checkbox"/> Set this parameter according to the motor nameplate. <input checked="" type="checkbox"/> 0 to 300Hz for V/F Control. <input checked="" type="checkbox"/> 30 to 120Hz for Vector Control.
<b>P404</b> <sup>(1)</sup> Motor Rated Power	0 to 50 [ 4 ] -	<input checked="" type="checkbox"/> Set this parameter according to the motor nameplate.

P404	Motor Rated Power (HP/kW)	P404	Motor Rated Power (HP/kW)
0	0.33/0.25	26	180.0/132.0
1	0.50/0.37	27	200.0/150.0
2	0.75/0.55	28	220.0/160.0
3	1.0/0.75	29	250.0/185.0
4	1.5 /1.1	30	270.0/200.0
5	2.0 /1.5	31	300.0/220.0
6	3.0 /2.2	32	350.0/260.0
7	4.0 /3.0	33	380.0/280.0
8	5.0 /3.7	34	400.0/300.0
9	5.5 /4.0	35	430.0/315.0
10	6.0/4.5	36	440.0/330.0
11	7.5/5.5	37	450.0/335.0
12	10.0/7.5	38	475.0/355.0
13	12.5/9.0	39	500.0/375.0
14	15.0/11.0	40	540.0/400.0
15	20.0/15.0	41	600.0/450.0
16	25.0/18.5	42	620.0/460.0
17	30.0/22.0	43	670.0/500.0
18	40.0/30.0	44	700.0/525.0
19	50.0/37.0	45	760.0/570.0
20	60.0/45.0	46	800.0/600.0
21	75.0/55.0	47	850.0/630.0
22	100.0/75.0	48	900.0/670.0
23	125.0/90.0	49	1100.0/ 820.0
24	150.0/110.0	50	1600.0/1190.0
25	175.0/130.0		

Table 6.57 - Motor rated power selection

Parameter	Range [Factory Setting] Unit	Description / Notes
<b>P405</b> <sup>(1)</sup> Encoder PPR	250 to 9999 [ 1024 ] 1	<input checked="" type="checkbox"/> Sets the number of pulses per revolution (PPR) of the incremental encoder, when P202 = 4 (Vector with Encoder).

 This parameter is shown on the display(s) only when P202 = 4 (Vector Control with Encoder)

<b>P406</b> <sup>(1)</sup> Motor Ventilation Type	0 to 3 [ 0 ] -	<table border="1"> <thead> <tr> <th>P406</th> <th>Function</th> </tr> </thead> <tbody> <tr> <td>0</td> <td>Self-ventilated</td> </tr> <tr> <td>1</td> <td>Forced Ventilation</td> </tr> <tr> <td>2</td> <td>Optimal Flux</td> </tr> <tr> <td>3</td> <td>Increased Protection</td> </tr> </tbody> </table> <p><b>Table 6.58</b> - Type of motor ventilation</p>	P406	Function	0	Self-ventilated	1	Forced Ventilation	2	Optimal Flux	3	Increased Protection
	P406	Function										
0	Self-ventilated											
1	Forced Ventilation											
2	Optimal Flux											
3	Increased Protection											

At the first drive power up (refer to items 5.2, 5.3 and 5.3.1) or when P202 is modified from 0, 1 or 2 (V/Hz) to 5 (VVW), 3 or 4 (Vector - see item 5.3.2), from 5 to 3 or 4 and vice versa, the value set at P406 automatically changes the overload protection as follows:

P406	P156	P157	P158
0	1.1xP401	0.9xP401	0.55xP401
1	1.1xP401	1.0xP401	1.0xP401
2	1.1xP401	1.0xP401	1.0xP401
3	0.98xP401	0.9xP401	0.55xP401

**Table 6.59** - Motor overload protection action



**ATTENTION!**



The option P406=2 may be used (see use conditions below) when motor should be operated at low frequencies with rated torque, without requiring forced ventilation, for the operation range 12:1, i.e., 5 at 60Hz/4.2 at 50Hz according the rated motor frequency.



**CONDITIONS FOR USING OPTION P406=2:**

- i. Sensorless Vector Mode (P202=3);
- ii. WEG motors series: Nema Premium Efficiency, Nema High Efficiency, IEC Premium Efficiency, IEC TOP Premium Efficiency and Alto rendimento Plus.

When P406=3, the switching frequency is limited to 5kHz.

Parameter	Range [Factory Setting] Unit	Description / Notes																								
<p><b>P407</b> <sup>(1) (2)</sup> Rated Motor Power Factor</p> <p> This parameter is shown on the display(s) only when P202 = 5 (VVW)</p>	<p>0.50 to 0.99 [ - ] -</p>	<ul style="list-style-type: none"> <li><input checked="" type="checkbox"/> This parameter sets the motor power factor;</li> <li><input checked="" type="checkbox"/> This parameter is important to the correct operation of the VVW control. The incorrect setting of this parameter results in the incorrect calculation of the slip compensation;</li> <li><input checked="" type="checkbox"/> The default value of this parameter is automatically set when parameter P404 is modified. The suggested value is valid only for IV pole standard three-phase WEG motors. The user shall set this parameter manually for other motor types.</li> </ul>																								
<p><b>P408</b> <sup>(1)</sup> Run Self-Tuning</p> <p> This parameter is shown on the display(s) only when P202 = 3 or 4 (Vector Control)</p> <p> The Self-tuning Routine can be cancelled by pressing the  key, only when P409 to P413 are different from zero.</p> <p> Self-tuning can be realized only with P309=Inactive (0)</p>	<p>0 to 2 [ P202=3 ] [ 0 ] 1</p> <p>0 to 4 [ P202=4 ] [ 0 ] 1</p> <p>0,1 [ P202=5 ] [ 0 ] 1</p>	<ul style="list-style-type: none"> <li><input checked="" type="checkbox"/> This parameter controls the self-tuning routine, which estimates the value of parameters related to the motor under use. When P408 is set to options 1, 2, or 3, the self-tuning routine estimates the value of parameters P409 to P413. When this parameter is set to option 4, the self-tuning routine only estimates the value of parameter P413.</li> </ul> <p>Note: Best results for the self-tuning routine are obtained with a hot motor.</p> <table border="1" style="margin-left: auto; margin-right: auto;"> <thead> <tr> <th>P408</th> <th>Self-tuning</th> <th>Type of Control</th> <th>P202</th> </tr> </thead> <tbody> <tr> <td>0</td> <td>No</td> <td>-</td> <td>-</td> </tr> <tr> <td>1</td> <td>No rotation</td> <td>Sensorless Vector, Vector with Encoder or VVW</td> <td>3,4 or 5</td> </tr> <tr> <td>2</td> <td>Run for lmr</td> <td>Sensorless Vector or Vector with Encoder</td> <td>3 or 4</td> </tr> <tr> <td>3</td> <td>Run for TM</td> <td>Vector with Encoder</td> <td>4</td> </tr> <tr> <td>4</td> <td>Measure TM</td> <td>Vector with Encoder</td> <td>4</td> </tr> </tbody> </table> <p style="text-align: center;"><i>Table 6.60 - Self-tuning options</i></p> <ul style="list-style-type: none"> <li>- <b>No rotation</b> - The motor remains stationary during the self-tuning routine. The value of P410 is obtained from a table, which is valid for WEG motors up to 12 poles. Thus, P410 shall be set to zero before starting the self-tuning routine. If P410 ≠ 0, the self-tuning routine will keep the existing value. Note: When using a non-WEG motor, set P410 to the proper value (no load current) before running the self-tuning routine.</li> <li>- <b>Run for lmr</b> - The value of P410 is estimated with the motor rotating. This option shall be executed with no load coupled to the motor.</li> </ul> <p> <b>ATTENTION!</b> If the self-tuning routine is executed with a load coupled to the motor and with P408 set to option 2 (Run for lmr), a wrong value of P410 (l<sub>mr</sub>) may be obtained. This will result in a wrong estimation of P412 (L<sub>r</sub>/T<sub>r</sub> Constant) and P413 (Mechanical Time Constant - TM). An overcurrent fault (E00) may also occur during the drive operation. Note: The word “load” represents anything coupled to the motor shaft such as a gearbox, an inertia wheel, etc.</p>	P408	Self-tuning	Type of Control	P202	0	No	-	-	1	No rotation	Sensorless Vector, Vector with Encoder or VVW	3,4 or 5	2	Run for lmr	Sensorless Vector or Vector with Encoder	3 or 4	3	Run for TM	Vector with Encoder	4	4	Measure TM	Vector with Encoder	4
P408	Self-tuning	Type of Control	P202																							
0	No	-	-																							
1	No rotation	Sensorless Vector, Vector with Encoder or VVW	3,4 or 5																							
2	Run for lmr	Sensorless Vector or Vector with Encoder	3 or 4																							
3	Run for TM	Vector with Encoder	4																							
4	Measure TM	Vector with Encoder	4																							

Parameter	Range [Factory Setting] Unit	Description / Notes
		<p>- <b>Run for TM</b> - The value of parameter P413 (Mechanical Time Constant - TM) is estimated with the motor rotating. It shall be run, preferentially, with the load coupled to the motor.</p> <p>- <b>Measure TM</b> – Estimates the value of P413 (Mechanical Time Constant – TM) with the motor rotating. It shall be run, preferentially, with the load coupled to the motor.</p> <p> <b>NOTES!</b></p> <ul style="list-style-type: none"> <li><input checked="" type="checkbox"/> When P408 = 1 or 2: The parameter P413 (Mechanical Time Constant – TM) is set to an approximated value of the motor mechanical time constant. The value of this parameter is set based on the motor rotor inertia (table data is valid for WEG motors), on the Drive Rated Current, and on the Drive Rated Voltage.</li> <li><input checked="" type="checkbox"/> Vector with Encoder control (P202 = 4): When P408 is set to option 2 (Run for lmr) and the self-tuning routine is finished, it is mandatory to couple the load to the motor and set parameter P408 to 4 (Measure TM) in order to estimate P413 (Mechanical Time Constant – TM). In this case, parameter P413 will also consider the driven load.</li> <li><input checked="" type="checkbox"/> VVW Control - Voltage Vector WEG (P202=5): In the self-tuning routine for the VVW control, only the mot stator resistance (P409) is obtained. Therefore, the self-tuning routine is always run with the motor stationary.</li> </ul>
<p><b>P409</b> <sup>(1)</sup> Motor Stator Resistance (Rs)</p> <p> This parameter is shown on the display(s) only when P202 = 3, 4 (Vector Control) a 5 (VVW)</p>	<p>0.000 to 77.95 [ 0.000 ] 0.001Ω</p>	<p><input checked="" type="checkbox"/> Value estimated by the Self-tuning routine.</p>

Parameter	Range [Factory Setting] Unit	Description / Notes
<b>P410</b> Motor Magnetizing Current ( $I_{mr}$ )   <b>This parameter is shown on the display(s) only when P202 = 3 or 4 (Vector Control)</b>	0 to 1.25xP295 [ 0.0 ] 0.1A	<ul style="list-style-type: none"> <li><input checked="" type="checkbox"/> When the motor can operate decoupled from the load (P408 = 2) this value is estimated by the Self-tuning routine (P408=1 or 3) otherwise it is obtained from a pre-stored value array valid for WEG motors.</li> <li><input checked="" type="checkbox"/> If a non WEG motor is being used set this parameter to the correct value before starting Self-tuning.</li> <li><input checked="" type="checkbox"/> For P202=4 (vector with encoder), the value set at P410 determines the motor flux. Thus ensure correct setting. If this setting is too low, the motor will lose flux and torque, if too high, the motor running starts to oscillate at rated speed or even this speed may not be reached. In this case, decrement P410 or P178 till speed oscillation stops or the rated speed is reached.</li> </ul>
<b>P411</b> <sup>(1)</sup> Motor Flux Leakage Inductance   <b>This parameter is shown on the display(s) only when P202 = 3 or 4 (Vector Control)</b>	0.00 to 99.99 [ 0.00 ] 0.01mH	<ul style="list-style-type: none"> <li><input checked="" type="checkbox"/> Value estimated by the Self-tuning routine.</li> </ul>
<b>P412</b> Lr/Rr Constant (Rotor Time Constant - Tr)   <b>This parameter is shown on the display(s) only when P202 = 3 or 4 (Vector Control)</b>	0.000 to 9.999 [ 0.000 ] 0.001s	<ul style="list-style-type: none"> <li><input checked="" type="checkbox"/> The setting of P412 determines the gains of the flux regulator (P175 and P176).</li> <li><input checked="" type="checkbox"/> The value of P412 is estimated by the self-tuning routine for motors up to 75hp/55kW. For higher ratings, this parameter is set according to the values for the WEG standard motors (table 6.61 shows typical values for some motors).</li> <li><input checked="" type="checkbox"/> The value of this parameter affects the speed accuracy for the sensorless vector mode control.</li> <li><input checked="" type="checkbox"/> Usually, the self-tuning routine is run when the motor is cold. Depending on the motor, the value of P412 may vary more or less according to the motor temperature. Therefore, when running a hot motor, adjust P412 so that the loaded motor speed (measured at the motor shaft with a tachometer) is the same as that indicated on the drive keypad (P001). This setting shall be performed at the half of the rated speed.</li> <li><input checked="" type="checkbox"/> For P202=4 (vector with encoder control), if the setting of P412 is incorrect the motor will lose torque. In this case, set P412 so that the motor current (P003) reaches the lowest value at the half of the rated speed and with a steady load.</li> <li><input checked="" type="checkbox"/> In the sensorless vector control the value of the parameter P175 will be limited in the range: <math>3,0 \leq P175 \leq 8,0</math>.</li> </ul>

Parameter	Range [Factory Setting] Unit	Description / Notes																																																																														
		<p>☑ Typical <math>T_R</math> values for WEG standard motors:</p> <table border="1"> <thead> <tr> <th rowspan="3">Motor Power cv-hp / kW</th> <th colspan="4"><math>T_R</math> (s):</th> </tr> <tr> <th colspan="4">Number of poles</th> </tr> <tr> <th>2 (50Hz/60Hz)</th> <th>4 (50Hz/60Hz)</th> <th>6 (50Hz/60Hz)</th> <th>8 (50Hz/60Hz)</th> </tr> </thead> <tbody> <tr> <td>2 / 1.5</td> <td>0.19 / 0.14</td> <td>0.13 / 0.14</td> <td>0.1 / 0.1</td> <td>0.07 / 0.07</td> </tr> <tr> <td>5 / 3.7</td> <td>0.29 / 0.29</td> <td>0.18 / 0.12</td> <td>- / 0.14</td> <td>0.14 / 0.11</td> </tr> <tr> <td>10 / 7.5</td> <td>- / 0.38</td> <td>0.32 / 0.25</td> <td>0.21 / 0.15</td> <td>0.13 / 0.14</td> </tr> <tr> <td>15 / 11</td> <td>0.52 / 0.36</td> <td>0.30 / 0.25</td> <td>0.20 / 0.22</td> <td>0.28 / 0.22</td> </tr> <tr> <td>20 / 15</td> <td>0.49 / 0.51</td> <td>0.27 / 0.29</td> <td>0.38 / 0.2</td> <td>0.21 / 0.24</td> </tr> <tr> <td>30 / 22</td> <td>0.70 / 0.55</td> <td>0.37 / 0.34</td> <td>0.35 / 0.37</td> <td>- / 0.38</td> </tr> <tr> <td>50 / 37</td> <td>- / 0.84</td> <td>0.55 / 0.54</td> <td>0.62 / 0.57</td> <td>0.31 / 0.32</td> </tr> <tr> <td>100 / 75</td> <td>1.64 / 1.08</td> <td>1.32 / 0.69</td> <td>0.84 / 0.64</td> <td>0.70 / 0.56</td> </tr> <tr> <td>150 / 110</td> <td>1.33 / 1.74</td> <td>1.05 / 1.01</td> <td>0.71 / 0.67</td> <td>- / 0.67</td> </tr> <tr> <td>200 / 150</td> <td>- / 1.92</td> <td>- / 0.95</td> <td>- / 0.65</td> <td>- / 1.03</td> </tr> <tr> <td>300 / 220</td> <td>- / 2.97</td> <td>1.96 / 2.97</td> <td>1.33 / 1.30</td> <td>- / -</td> </tr> <tr> <td>350 / 250</td> <td>- / -</td> <td>1.86 / 1.85</td> <td>- / 1.53</td> <td>- / -</td> </tr> <tr> <td>500 / 375</td> <td>- / -</td> <td>- / 1.87</td> <td>- / -</td> <td>- / -</td> </tr> </tbody> </table> <p><i>Table 6.61 - Typical <math>T_R</math> values for some WEG standard motors.</i></p>	Motor Power cv-hp / kW	$T_R$ (s):				Number of poles				2 (50Hz/60Hz)	4 (50Hz/60Hz)	6 (50Hz/60Hz)	8 (50Hz/60Hz)	2 / 1.5	0.19 / 0.14	0.13 / 0.14	0.1 / 0.1	0.07 / 0.07	5 / 3.7	0.29 / 0.29	0.18 / 0.12	- / 0.14	0.14 / 0.11	10 / 7.5	- / 0.38	0.32 / 0.25	0.21 / 0.15	0.13 / 0.14	15 / 11	0.52 / 0.36	0.30 / 0.25	0.20 / 0.22	0.28 / 0.22	20 / 15	0.49 / 0.51	0.27 / 0.29	0.38 / 0.2	0.21 / 0.24	30 / 22	0.70 / 0.55	0.37 / 0.34	0.35 / 0.37	- / 0.38	50 / 37	- / 0.84	0.55 / 0.54	0.62 / 0.57	0.31 / 0.32	100 / 75	1.64 / 1.08	1.32 / 0.69	0.84 / 0.64	0.70 / 0.56	150 / 110	1.33 / 1.74	1.05 / 1.01	0.71 / 0.67	- / 0.67	200 / 150	- / 1.92	- / 0.95	- / 0.65	- / 1.03	300 / 220	- / 2.97	1.96 / 2.97	1.33 / 1.30	- / -	350 / 250	- / -	1.86 / 1.85	- / 1.53	- / -	500 / 375	- / -	- / 1.87	- / -	- / -
Motor Power cv-hp / kW	$T_R$ (s):																																																																															
	Number of poles																																																																															
	2 (50Hz/60Hz)	4 (50Hz/60Hz)	6 (50Hz/60Hz)	8 (50Hz/60Hz)																																																																												
2 / 1.5	0.19 / 0.14	0.13 / 0.14	0.1 / 0.1	0.07 / 0.07																																																																												
5 / 3.7	0.29 / 0.29	0.18 / 0.12	- / 0.14	0.14 / 0.11																																																																												
10 / 7.5	- / 0.38	0.32 / 0.25	0.21 / 0.15	0.13 / 0.14																																																																												
15 / 11	0.52 / 0.36	0.30 / 0.25	0.20 / 0.22	0.28 / 0.22																																																																												
20 / 15	0.49 / 0.51	0.27 / 0.29	0.38 / 0.2	0.21 / 0.24																																																																												
30 / 22	0.70 / 0.55	0.37 / 0.34	0.35 / 0.37	- / 0.38																																																																												
50 / 37	- / 0.84	0.55 / 0.54	0.62 / 0.57	0.31 / 0.32																																																																												
100 / 75	1.64 / 1.08	1.32 / 0.69	0.84 / 0.64	0.70 / 0.56																																																																												
150 / 110	1.33 / 1.74	1.05 / 1.01	0.71 / 0.67	- / 0.67																																																																												
200 / 150	- / 1.92	- / 0.95	- / 0.65	- / 1.03																																																																												
300 / 220	- / 2.97	1.96 / 2.97	1.33 / 1.30	- / -																																																																												
350 / 250	- / -	1.86 / 1.85	- / 1.53	- / -																																																																												
500 / 375	- / -	- / 1.87	- / -	- / -																																																																												
<p><b>P413</b> <sup>(1)</sup>  <math>T_M</math> Constant                      (Mechanical Time Constant)</p> <p> This parameter is shown on the display(s) only when P202 = 3 or 4 (Vector Control)</p>	0.00 to 99.99 [ 0.00 ] 0.01s	<p>☑ The setting of P413 determines the gains of the speed regulator (P161 and P162).</p> <p>☑ When P408 = 1 or 2, observe the following:</p> <ul style="list-style-type: none"> <li>- If P413 = 0, then the TM constant will be obtained as a function of the motor inertia (memory stored value).</li> <li>- If P413 &gt; 0, then the value of P413 will not be changed during the self-tuning routine.</li> </ul> <p><b>Sensorless vector control (P202=3):</b></p> <p>☑ When the value of P413 (obtained from the self-tuning routine) provides unsuitable gains for the speed regulator, modify this parameter to better adjust the speed regulator gains;</p> <p>☑ The value of P161, provided by the self-tuning routine or through the changing of P413, will be limited in the range: <math>6,0 \leq P161 \leq 9,0</math>.</p> <p>☑ The value of P162 varies according to the value of P161.</p> <p>☑ In case it is needed to increase more these gains, set them directly at P161 and P162.</p> <p><b>Note:</b> Values of P161 &gt; 12,0 may cause oscillations in the torque current (<math>i_q</math>) and in the speed.</p> <p><b>Vector with encoder control (P202=4):</b></p> <p>☑ The value of P413 is estimated by the self-tuning routine when P408 = 3 or 4. In case it is not possible to estimate it, the setting shall be performed manually. (Refer to P161/P162).</p>																																																																														

6.5 SPECIAL FUNCTIONS  
PARAMETERS -  
P500 to P699

6.5.1 PID Regulator

- ☑ The CFW-09 is fitted with the PID regulator that can be used for closed loop process control. This function acts as a proportional, integral and derivative regulator, superimposed on the normal inverter speed control.
- ☑ The speed will be changed in order to maintain the process variable (the variable that should be controlled - for instance: water level of a container) at the desired value, set in the setpoint.
- ☑ This regulator can control, for example, the flow in a piping system through the flow feedback to the analog input AI2 or AI3 (selected via P524), and the flow reference set at P221 or P222 - AI1, when the inverter drives the motor of a pump that circulates the fluid through this piping system.
- ☑ Other application examples: level control, temperature control, dosing control, etc.

6.5.2 Description

- ☑ The function of the PID regulator is activated by setting P203 to 1.
- ☑ Figure 6.50 shows the block diagram of the Academic PID regulator.
- ☑ The transference function in the frequency domain of the Academic PID regulator is:

$$y(s) = Kp e(s) \left[ 1 + \frac{1}{sTi} + sTd \right]$$

Substituting the integrator by a sum and the derivative by the incremental quotient, we will obtain an approximate value for the discrete (recursive) transfer equation shown below:

$$y(kTa) = y(k-1)Ta + Kp[(e(kTa) - e(k-1)Ta) + Kie(k-1)Ta + Kd(e(kTa) - 2e(k-1)Ta + e(k-2)Ta)]$$

where:

- $Kp$  (Proportional Gain):  $Kp = P520 \times 4096$ ;
- $Ki$  (Integral Gain) :  $Ki = P521 \times 4096 = [Ta/Ti \times 4096]$ ;
- $Kd$  (Differential Gain) :  $Kd = P522 \times 4096 = [Td/Ta \times 4096]$ .
- $Ta = 0,02\text{sec}$ (sampling period of the PID Regulator).
- $SP^*$  : reference, has 13 bits max. (0 to 8191).
- $X$  : process variable (or controlled), read at AI2 or AI3, has 13 bits maximum;
- $y(kTa)$ : current PID output, has 13 bits maximum;
- $y(k-1)Ta$ : previous OPID output;
- $e(kTa)$ : current error [ $SP^*(k) - X(k)$ ];
- $e(k-1)Ta$ : previous error [ $SP^*(k-1) - X(k-1)$ ];
- $e(k-2)Ta$ : error of the two previous samplings [ $SP^*(k-2) - X(k-2)$ ];

- ☑ The feedback signal must be sent to the analog inputs AI2' and AI3' (See figure 6.29 and 6.30).



**NOTE!**

When using the PID function P233 must be set to 1, otherwise the minimum speed (P133) will be added to the PID feedback via AI2.

**The setpoint can be defined:**

- ☑ Keypad: parameter P525.
- ☑ Analog inputs AI1', AI2', AI3', AI4', (AI1'+ AI2')>0, (AI1'+ AI2'), Multispeed, Serial, Fieldbus and PLC.



**NOTE!**

When P203=1, do not use the reference via EP (P221/P222=7).

**When the PID function (P203=1) is set:**

- ☑ The following parameters are automatically changed: P223=0 (always forward), P225=0 (JOG disabled), P226=0 (always forward), P228=0 (JOG disabled), P237=3 (PID process variable) e P265=15 (Manual/Automatic).
- ☑ The JOG Function and the direction of rotation function remain disabled. The Enabling and Start/Stop controls are defined in P220, P224 and P227.
- ☑ The digital input DI3 is programmed automatically for the function Manual/Automatic (P265=15), according to table 6.61:

Dlx	Operating Mode
0 (0V)	Manual
1 (24V)	Automatic

*Table 6.62 - Dlx Operating Mode*

- ☑ The change between Manual/Automatic can be realized by one of the digital inputs DI3 to DI8 (**P265 to P270**).
- ☑ Parameter P040 indicates the value of the Process Variable feedback) in the chosen scale/unit. This parameter can be selected as monitoring variable (see Item 4.2.2), provided P205=6. To prevent the saturation of the analog feedback input during the regulation “overshoot”, the signal must vary between 0V to 9.0V [(0 to 18) mA / (4 to 18) mA]. The adaptation between the setpoint and the feed back can be realized by changing the gain of the selected analog input as feedback (P238 for AI2 or P242 for AI3). The Process Variable can also be displayed at the outputs AO1 to AO4 provided they were programmed at P251, P253, P255 or P257. The same is valid for the PID setpoint.
- ☑ The outputs DO1, DO2 and RL1 to RL3 can be programmed (P275 to P277, P279 or P280) to the functions of the Process Variable > VPx (P533) and Process Variable < VPy (P534).
- ☑ When the setpoint is defined by P525 (P221 or P222=0), and if it is changed from manual to automatic, following setting P525=P040 is performed automatically, provided the parameter P536 is active. In this case, the commutation from manual to automatic is smooth (there is no abrupt speed oscillation).
- ☑ In case of function “Stop Logic” is active (P211=1) and P224=0, P224 is automatically changed to the option “Digital Input (Dlx)” (P224=1).
- ☑ In case of function “Stop Logic” is active (P211=1) and P227=0, P227 is automatically changed to the option “Digital Input (Dlx)” (P227=1).

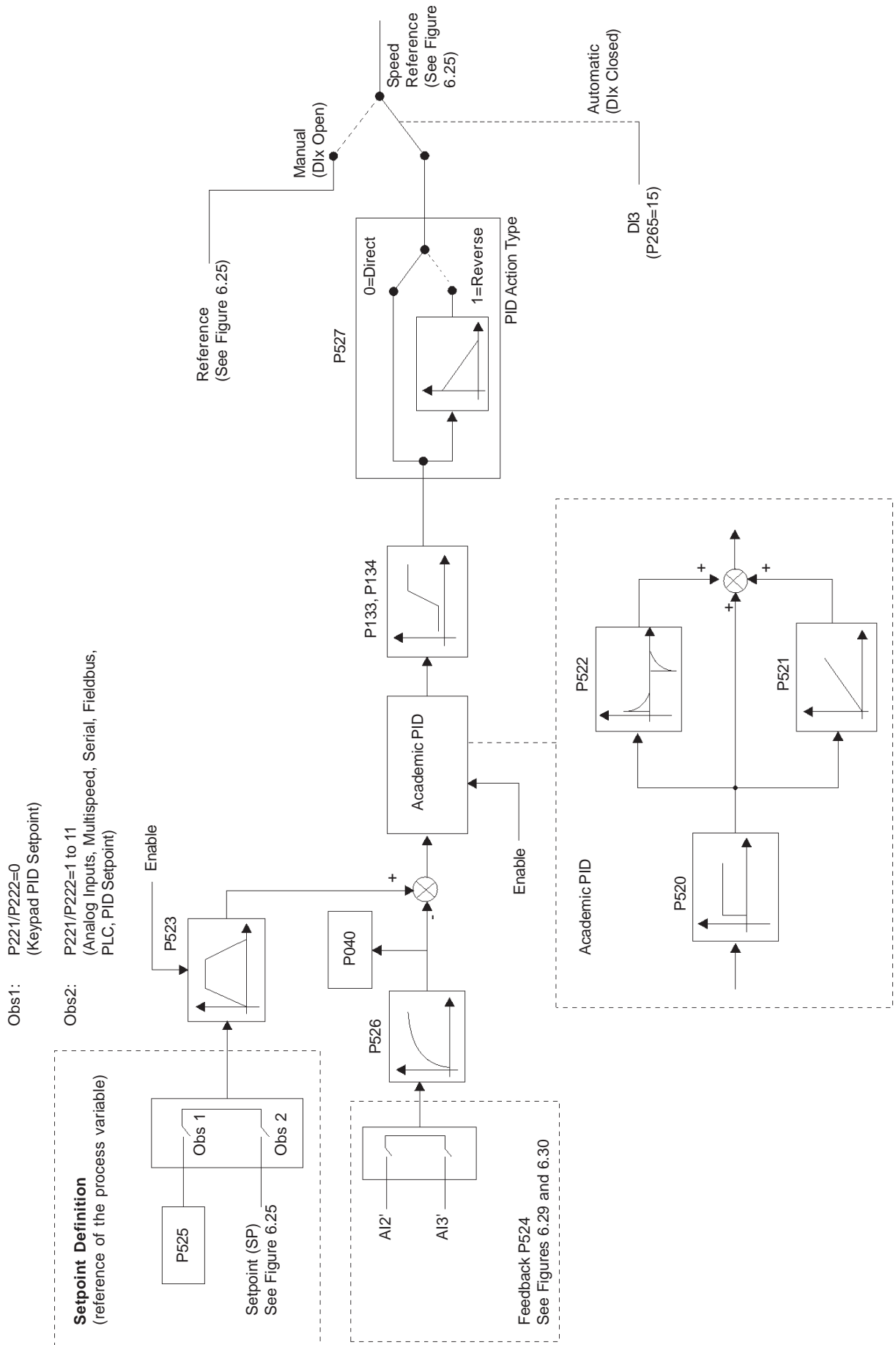

Figure 6.48 - Block diagram of the PID Regulator Function

Parameter	Range [Factory Setting] Unit	Description / Notes
<b>P520</b> PID Proportional Gain	0.000 to 7.999 [ 1.000 ] 0.001	<input checked="" type="checkbox"/> Some examples of initial settings of the PID Regulator Gains and PID Ramp Times for some applications mentioned in Item 6.5.1, are shown in table 6.63.
<b>P521</b> PID Integral Gain	0.000 to 7.999 [ 0.043 ] 0.001	
<b>P522</b> PID Differential Gain	0.000 to 3.499 [ 0.000 ] 0.001	
<b>P523</b> PID Ramp Time	0.0 to 999 [ 3.0 ] 0.1s (<99.9s) 1s (>99.9s)	

Magnitude	Gains			PID Ramp Time P523	Action Time P527
	Proportional P520	Integral P521	Derivative P522		
Pressure pneumatic system	1	0.043	0.000	3.0	0 = Direct
Flow pneumatic system	1	0.037	0.000	3.0	0 = Direct
Pressure hydraulic system	1	0.043	0.000	3.0	0 = Direct
Flow hydraulic system	1	0.037	0.000	3.0	0 = Direct
Temperature	2	0.004	0.000	3.0	See Note
Level	1	See Note	0.000	3.0	See Note

**Table 6.63** - Suggestions for gain settings of the PID regulator

**Obs:**

- For temperature and level control, the action type will depend on the process. For instance, in the level control, when the inverter drives the motor that removes fluid from a tank, the action will be contrary as when the inverter drives the motor that fills a tank and thus the fluid level increases and the inverter should increase the motor speed to lower the fluid level, otherwise the inverter action that drives the pump motor to pump fluid into the tank will be direct.
- In case of level control, the setting of the integral gain will depend on the time required to fill the tank from the minimum acceptable level up the desired level, in the following conditions:
  - i. For the direct action, the time should be measured by considering the maximum input flow and the minimum output flow.
  - ii. In the inverse action, the time should be measured by considering the minimum input flow and the maximum output flow.

The equation to calculate an initial value for P521 (PID Integral Gain) as a function of the system response time, is presented below:

$$P521 = 0.02 / t$$

t=time (seconds)

<b>P524</b> Selection of the PID Feedback	0,1 [ 0 ] -	<input checked="" type="checkbox"/> It selects the feedback input (Process Variable) of the PID regulator:
---	-------------------	--

P524	AIx
0	AI2 (P237 to P240)
1	AI3 (P241 to P244)

**Table 6.64** - Feedback selection





Parameter	Range [Factory Setting] Unit	Description / Notes						
		<ul style="list-style-type: none"> <li><input checked="" type="checkbox"/> After the feedback input has been chosen, you must set the input function selected at P237 (to AI2) or P241 (to AI3).</li> </ul> <p><b>Feedback Type:</b></p> <ul style="list-style-type: none"> <li><input checked="" type="checkbox"/> The PID action Type described above considers that the variable feedback signal increases when the process variable also increases (direct feedback). This is the most common used feedback type.</li> <li><input checked="" type="checkbox"/> When the process variable feedback decreases when the process variable increases (inverse feedback), It is required to program the selected analog input for the PID (AI2 or AI3) as inverse reference: P239=2 [(10 to 0)V/(20 to 0)mA] or P239=3 [(20 to 4)mA]. When the feedback is through AI2 and P243=2 [(10 to 0)V/(20 to 0)mA] or P243=3 [(20 to 4)mA] when the feedback is through AI3. When this setting is not present, PID does not operate correctly.</li> </ul>						
<b>P525</b> Keypad PID Setpoint	0.0 to 100 [ 0.0 ] 0.1%	<ul style="list-style-type: none"> <li><input checked="" type="checkbox"/> It provides the setpoint via the  and  keys for the PID Regulator (P203=1) provided that P221=0 (LOC) or P222=0 (REM) and the inverter is in the Automatic mode. If it has been set to Manual Mode, the speed reference is given by P121.</li> <li><input checked="" type="checkbox"/> The value of P525 is maintained at the last set value (backup), even when inverter is disabled or enabled with [P120 = 1 (Active)].</li> <li><input checked="" type="checkbox"/> Once PID is in Automatic mode, the Setpoint value for PID regulator is entered into the CFW09 via any reference set by P221 (LOCAL mode) or P222 (REMOTE mode). Particularly, most of general PID applications uses the setpoint via the AI1 [P221=1 (LOC) or P222=1(REM)] or via the  and  keys [P221=0 (LOC) or P222=0(REM)]. Refer to Figure 6.48 Block Diagram of the PID Regulator.”</li> </ul>						
<b>P526</b> Process Variable Filter	0.0 to 16.0 [ 0.1 ] 0.1s	<ul style="list-style-type: none"> <li><input checked="" type="checkbox"/> It sets the time constant of the Process Variable Filter.</li> <li><input checked="" type="checkbox"/> Generally a 0.1 will be a suitable value, excepting the process variable signal has a too high noise level. In this case, increase this value gradually by checking the result.</li> </ul>						
<b>P527</b> PID Action Type	0,1 [ 0 ] -	<ul style="list-style-type: none"> <li><input checked="" type="checkbox"/> It defines the control action type:</li> </ul> <table border="1" style="margin-left: auto; margin-right: auto;"> <thead> <tr> <th>P527</th> <th>Action Type</th> </tr> </thead> <tbody> <tr> <td>0</td> <td>DIRECT</td> </tr> <tr> <td>1</td> <td>REVERSE</td> </tr> </tbody> </table>	P527	Action Type	0	DIRECT	1	REVERSE
P527	Action Type							
0	DIRECT							
1	REVERSE							

Table 6.65 - PID action type

Parameter	Range [Factory Setting] Unit	Description / Notes								
		<p><input checked="" type="checkbox"/> Select according to the process</p> <table border="1"> <thead> <tr> <th>Motor Speed</th> <th>Process Variable</th> <th>Select</th> </tr> </thead> <tbody> <tr> <td rowspan="2">INCREASE</td> <td>INCREASE</td> <td>DIRECT</td> </tr> <tr> <td>DECREASE</td> <td>REVERSE</td> </tr> </tbody> </table> <p><i>Table 6.66 - PID action selection</i></p> <p><b>Process requirement:</b></p> <p><input checked="" type="checkbox"/> PID action type: the PID action should be selected as direct, when it is required to increase the motor speed in order to increase the process variable. Otherwise, select the inverse.</p> <p><input checked="" type="checkbox"/> Example 1 - Direct: pump driven by frequency inverter and filling a tank, where PID regulates the level. To increase the level (process variable) it is required to increase the flow and consequently, the motor speed.</p> <p><input checked="" type="checkbox"/> Example 2 - Inverse: Fan driven by frequency inverter and cooling a cooling tower, with PID controlling its temperature. When the temperature (process variable) should be increased, the cooling effect should be reduced by reducing the motor speed.</p>	Motor Speed	Process Variable	Select	INCREASE	INCREASE	DIRECT	DECREASE	REVERSE
Motor Speed	Process Variable	Select								
INCREASE	INCREASE	DIRECT								
	DECREASE	REVERSE								
<p><b>P528</b> Process Variable Scale Factor</p>	<p>1 to 9999 [ 1000 ] 1</p>	<p><input checked="" type="checkbox"/> P528 and P529 define the way the Process variable (P040) will be shown.</p> <p><input checked="" type="checkbox"/> P529 defines how many digits are indicated after the decimal point.</p> <p><input checked="" type="checkbox"/> P528 must be set according to the equation below:</p> $P528 = \frac{\text{F. S. V. Indication Process} \times (10)^{P529}}{\text{Gain (AI2 or AI3)}}$ <p>where:</p> <p>F. S. V. Indication Process is the full scale value of the Process Variable, corresponding to 10V (20mA) at the Analog Input (AI2 or AI3) used as feedback.</p> <p><input checked="" type="checkbox"/> Example 1: (Pressure Transducer 0 to 25 bar - Output 4 to 20 mA)</p> <ul style="list-style-type: none"> <li>- Desired indication: 0 to 25 bar (F. S.)</li> <li>- Feedback Input: AI3</li> <li>- Gain AI3=P242=1.000</li> <li>- Signal AI3=P243=1 (4 to 20mA)</li> <li>- P529=0 (no digit after decimal point)</li> </ul> $P528 = \frac{25 \times (10)^0}{1.000} = 25$								
<p><b>P529</b> Decimal Point of Process Variable</p>	<p>0 to 3 [ 1 ] -</p>									

Parameter	Range [Factory Setting] Unit	Description / Notes		
		<p>☑ Example 2 (values are factory standards):</p> <ul style="list-style-type: none"> <li>- Desired indication: 0.0% to 100.0% (F. S.)</li> <li>- Feedback Input: AI2</li> <li>- Gain AI2=P238=1.000</li> <li>- P529=1 (one number after decimal point)</li> </ul> $P528 = \frac{100.0 \times (10)^1}{1.000} = 1000$		
<p><b>P530</b> Eng. Unit Proc. Var. 1</p>	<p>32 to 127 [ 37 (%) ] -</p>	<p>☑ These parameters are only useful, if the inverter is fitted with HMI with LCD display.</p> <p>☑ The Engineering Unit of the Process Variable is formed by three characters, that are used for the indication of P040. P530 defines the left character, P531 defines the central character and P532 defines the right character.</p>		
<p><b>P531</b> Eng. Unit Proc. Var. 2</p>	<p>32 to 127 [ 32 ( ) ] -</p>	<p>☑ Possible characters to be chosen:</p>		
<p><b>P532</b> Eng. Unit Proc. Var. 3</p>	<p>32 to 127 [ 32 ( ) ] -</p>	<p>☑ Characters corresponding to the ASCII code from 32 to 127.</p> <p>Examples: A, B, ... , Y, Z, a, b, ... , y, z, 0, 1, ... , 9, #, \$, %, (, ), *, +, ...</p> <p>Examples:</p> <table style="width: 100%; border-collapse: collapse;"> <tr> <td style="width: 50%; vertical-align: top;"> <p>- To indicate "bar":</p> <p>P530="b" (98)</p> <p>P531="a" (97)</p> <p>P532="r" (114)</p> </td> <td style="width: 50%; vertical-align: top;"> <p>- To indicate "%":</p> <p>P530="%" (37)</p> <p>P531=" " (32)</p> <p>P532=" " (32)</p> </td> </tr> </table>	<p>- To indicate "bar":</p> <p>P530="b" (98)</p> <p>P531="a" (97)</p> <p>P532="r" (114)</p>	<p>- To indicate "%":</p> <p>P530="%" (37)</p> <p>P531=" " (32)</p> <p>P532=" " (32)</p>
<p>- To indicate "bar":</p> <p>P530="b" (98)</p> <p>P531="a" (97)</p> <p>P532="r" (114)</p>	<p>- To indicate "%":</p> <p>P530="%" (37)</p> <p>P531=" " (32)</p> <p>P532=" " (32)</p>			
<p><b>P533</b> Value of Proc. Var. X</p>	<p>0.0 to 100 [ 90.0 ] 0.1%</p>	<p>☑ Used in the functions of the Digital/Relay Outputs: V. Pr. &gt; VPx and V. Pr. &lt; VPy aiming signaling/alarm.</p>		
<p><b>P534</b> Value of Proc. Var. Y</p>	<p>0.0 to 100 [ 10.0 ] 0.1%</p>	<p>☑ Full scale percentual values of the Process Variable:</p> $(P040 = \frac{(10)^{P529}}{P528} \times 100\%)$		

Parameter	Range [Factory Setting] Unit	Description / Notes						
<b>P535</b> Wake Up Band	0 to 100 [ 0 ] 1%	<ul style="list-style-type: none"> <li><input checked="" type="checkbox"/> The value of this parameter is used along with P212 (Condition to Leave Zero Speed Disable), providing additional condition to leave zero speed disable, that is, error of PID &gt; P535. See P211 to P213.</li> <li><input checked="" type="checkbox"/> When the setpoint of the PID regulator is by HMI (P221/P222 = 0) and P536 is zero (active) by commutating from manual to automatic, the process variable value will be loaded at P525. In this way do you prevent PID oscillations during the commutation from "Manual" to "Automatic".</li> </ul>						
<b>P536</b> <sup>(1)</sup> Automatic Set of P525	0,1 [ 0 ] -	<table border="1" style="margin-left: auto; margin-right: auto;"> <thead> <tr> <th>P536</th> <th>Action Type</th> </tr> </thead> <tbody> <tr> <td>0</td> <td>Active</td> </tr> <tr> <td>1</td> <td>Inactive</td> </tr> </tbody> </table> <p style="text-align: center;"><i>Table 6.67 - Automatic Set of P525</i></p>	P536	Action Type	0	Active	1	Inactive
P536	Action Type							
0	Active							
1	Inactive							
<b>P537</b> Hysteresis for the Set Point = Process Variable	0 to 100 [ 1 ] 1%	<ul style="list-style-type: none"> <li><input checked="" type="checkbox"/> When the Set Point value is equal to the Process Variable and it is within the range defined by the hysteresis value (set at parameter P537), the digital or relay output set to the option Set Point = Process Variable (SP=PV) is activated and remains in this condition until the process variable reaches a value outside of the hysteresis range (refer to figure 6.39 v).</li> </ul> <p> <b>NOTE!</b> This function is enabled only in the automatic mode and when P203=1.</p>						
<b>P538</b> Hysteresis VPx/VPy	0.0 to 5.0 [ 1.0 ] 0.1%	<ul style="list-style-type: none"> <li><input checked="" type="checkbox"/> It is used in functions of the digital and relay outputs: Process Variable &gt; VPx and Process Variable &lt; VPy</li> </ul>						

DIAGNOSTICS AND TROUBLESHOOTING

This Chapter assists the user to identify and correct possible faults that can occur during the CFW-09 operation. Guidance on Preventive Maintenance is also provided.

7.1 FAULTS AND POSSIBLE CAUSES

When a fault is detected, the inverter is disabled and the Fault Code is displayed on the readout in the EXX form, where XX is the actual Fault Code. (ie. E01).

To restart the inverter after a fault has occurred, the inverter must be reset. The reset can be made as follows:

- ☑ Disconnecting and reapplying AC power (power-on reset);
- ☑ By pressing the key  (manual reset);
- ☑ Automatic reset through P206 (auto-reset);
- ☑ By digital input: DIx=12 (P265 to P270).

The table below defines each Fault Code, explains how to reset the fault and shows the possible causes for each Fault Code.

FAULT	RESET	POSSIBLE CAUSES
E00 Output Overcurrent	<ul style="list-style-type: none"> <li>☑ Power-on</li> <li>☑ Manual reset (Key  )</li> <li>☑ Auto-reset</li> <li>☑ DIx (Digital Input)</li> </ul>	<ul style="list-style-type: none"> <li>☑ Short-circuit between two motor phases;</li> <li>☑ Short-circuit between breaking resistor cables;</li> <li>☑ Inertia of the load too high, or acceleration ramp too short;</li> <li>☑ Transistor module shorted;</li> <li>☑ Improper setting of regulation and/or configuration parameter(s);</li> <li>☑ P169 to P172 set too high.</li> </ul>
E01 Overvoltage (Ud)		<ul style="list-style-type: none"> <li>☑ Power Supply voltage too high, check Ud in P004: 220-230V Models - Ud &gt; 400V 380-480V Models - Ud &gt; 800V 500-600V and 500-690V Models with power supply between 500V and 600V - Ud &gt; 1000V 500-690 V models with power supply between 660V and 690V and 660-690V models - Ud &gt; 1200V</li> <li>☑ Load inertia too high or deceleration ramp too short.</li> <li>☑ P151 or P153 set too high.</li> </ul>
E02 Undervoltage (Ud)		<ul style="list-style-type: none"> <li>☑ Power Supply voltage too low, DC Link check Ud in P004: 220-230V power supply - Ud &lt; 223V 380V power supply - Ud &lt; 385V 400-415V power supply - Ud &lt; 405V 440-460V power supply - Ud &lt; 446V 480V power supply - Ud &lt; 487V 500-525V power supply - Ud &lt; 532V 550-575V power supply - Ud &lt; 582V 600V power supply - Ud &lt; 608V 660-690V power supply - Ud &lt; 699V</li> <li>☑ Phase loss at the input;</li> <li>☑ Auxiliary circuit fuse blown (only valid for 105A and 130A/220-230V, 86A to 600A/380-480V and 44A to 79A/500-600Vsee Section 3.2.3);</li> <li>☑ Pre-charge contactor defective;</li> <li>☑ P296 set to a voltage higher than the power supply voltage.</li> </ul>

Table 7.1 - Faults and possibles causes



FAULT	RESET	POSSIBLE CAUSES
E03 Input Undervoltage/ Phase loss <sup>(1)</sup>	<input checked="" type="checkbox"/> Power-on <input checked="" type="checkbox"/> Manual reset (Key  ) <input checked="" type="checkbox"/> Auto-reset <input checked="" type="checkbox"/> Dlx (Digital Input)	<input checked="" type="checkbox"/> Power Supply voltage is too low, check Power Supply voltage: 220-230V Models - Power Supply < 154V 380-480V Models - Power Supply < 266V 500-600V and 500-690V Models - Power Supply < 361V 660-690V Models - Power Supply < 462V <input checked="" type="checkbox"/> Phase loss at the inverter input. <input checked="" type="checkbox"/> Activation Time: 2.0s
E04 Inverter Overtemperature or Pre-charge Circuit Defective <sup>(2) (3)</sup>	<input checked="" type="checkbox"/> Power-on <input checked="" type="checkbox"/> Manual reset (Key  ) <input checked="" type="checkbox"/> Auto-reset <input checked="" type="checkbox"/> Dlx (Digital Input)	<input checked="" type="checkbox"/> Ambient temperature too high (>40°C) and/or output current too high; or ambient temperature < -10°C; <input checked="" type="checkbox"/> Blowers locked or defective <sup>(3)</sup> <input checked="" type="checkbox"/> Auxiliary circuit fuse blown (only valid for 105A and 130A/220-230V, 86A to 600A/380-480V and 44A to 79A/500-600Vsee Section 3.2.3); <input checked="" type="checkbox"/> Problem with the supply voltage - voltage sag or interruption (phase loss) - last for more than 2 seconds and with the phase loss detection disabled (P214=0); <input checked="" type="checkbox"/> Signal with inverted Polarity at Analog inputs AI1/AI2.
E05 Inverter / Motor Overload Ixt Function		<input checked="" type="checkbox"/> P156, P157 and P158 set too low for the motor being used; <input checked="" type="checkbox"/> Motor is under an actual overload condition.
E06 External Fault		<input checked="" type="checkbox"/> Any Dlx (DI3 to DI7) programmed for external fault detection (P265 to P270 set to 4 – No Ext Flt) is open (not connected to + 24V); <input checked="" type="checkbox"/> Terminal block XC12 on the control board CC9 is not properly connected.
E07 Encoder Fault (Valid only if P202 = 4 - Vector with Encoder)		<input checked="" type="checkbox"/> Miswiring between encoder and terminal block XC9 (optional board EBA/EBB). Refer to Section 8.2; <input checked="" type="checkbox"/> Encoder is defective.
E08 CPU Error (watchdog)		<input checked="" type="checkbox"/> Electrical noise.
E09 Program Memory Error (Checksum)	Contact WEG (Refer to Section 7.3)	<input checked="" type="checkbox"/> Memory with corrupted values.
E10 Error in the Copy Function	<input checked="" type="checkbox"/> Power-on <input checked="" type="checkbox"/> Manual Reset (Key  ) <input checked="" type="checkbox"/> Auto-reset <input checked="" type="checkbox"/> Dlx	<input checked="" type="checkbox"/> A bid to copy the HMI parameters to the inverter with different Software version.
E11 <sup>(7)</sup> Ground Fault		<input checked="" type="checkbox"/> Short-circuit between one or more output phases and ground; <input checked="" type="checkbox"/> Motor cable capacitance to ground is too high.

Table 7.1 - Faults and possibles causes (cont.)









FAULT	RESET	POSSIBLE CAUSES
E12 Braking Resistor Overload	<input checked="" type="checkbox"/> Power-on <input checked="" type="checkbox"/> Manual Reset (Key  ) <input checked="" type="checkbox"/> Auto-reset <input checked="" type="checkbox"/> DIx	<input checked="" type="checkbox"/> Load inertia too high or deceleration ramp too short; <input checked="" type="checkbox"/> Load on the motor shaft too high; <input checked="" type="checkbox"/> P154 and P155 programmed incorrectly.
E13 Incorrect encoder sense of rotation (for P202 = 4 - Encoder), with P408=runs to I <sub>mr</sub>	 Do not reset this fault and restart without first correcting the direction of either the encoder or of the motor.	<input checked="" type="checkbox"/> Cables U, V, W to motor are inverted; <input checked="" type="checkbox"/> Encoder channels A and B are inverted; <input checked="" type="checkbox"/> Encoder mounted in wrong position.  Note: This fault can only occur during Self-tuning.
E15 Motor Phase Loss	<input checked="" type="checkbox"/> Power-on <input checked="" type="checkbox"/> Manual Reset (Key  ) <input checked="" type="checkbox"/> Auto-reset <input checked="" type="checkbox"/> DIx	<input checked="" type="checkbox"/> Bad contact or broken wiring between motor and inverter; <input checked="" type="checkbox"/> Incorrect value programmed in P401; <input checked="" type="checkbox"/> Vector control without orientation; <input checked="" type="checkbox"/> Vector control with encoder, encoder wiring or connection to motor is inverted.
E17 Overspeed Fault	<input checked="" type="checkbox"/> Power-on <input checked="" type="checkbox"/> Manual Reset (Key  ) <input checked="" type="checkbox"/> Auto-reset <input checked="" type="checkbox"/> DIx	<input checked="" type="checkbox"/> When the effective overspeed exceeds the value of P134+P132 longer than 20ms.
E24 Programming Error <sup>(6)</sup>	It is automatically reset when the incompatible parameters are correctly programmed.	<input checked="" type="checkbox"/> Incompatible parameters were programmed. Refer to Table 4.2.
E31 Keypad (HMI) Connection Fault	It is automatically reset when HMI communication with inverter is reestablished.	<input checked="" type="checkbox"/> Keypad cable misconnected; <input checked="" type="checkbox"/> Electrical noise in the installation (electromagnetic interference).
E32 Motor Overtemperature <sup>(4)</sup>	<input checked="" type="checkbox"/> Power-on <input checked="" type="checkbox"/> Manual Reset (Key  ) <input checked="" type="checkbox"/> Auto-reset <input checked="" type="checkbox"/> DIx	<input checked="" type="checkbox"/> Motor is under an actual overload condition; <input checked="" type="checkbox"/> Duty cycle is too high (too many starts/stops per minute); <input checked="" type="checkbox"/> Ambient temperature is too high; <input checked="" type="checkbox"/> Motor thermistor.miswiring or short-circuit (resistance < 100Ω) at the terminals XC4:2 and 3 of the optional board EBA or at the terminals XC5:2 and 3 of the optional board EBB. <input checked="" type="checkbox"/> P270 programmed to 16 unintentionally, with EBA/EBB board not installed and/or motor thermistor not connected; <input checked="" type="checkbox"/> Motor in locked rotor condition.
E33 Speed without Control <sup>(8)</sup>	<input checked="" type="checkbox"/> Power-on <input checked="" type="checkbox"/> Manual Reset (Key  ) <input checked="" type="checkbox"/> Auto Reset <input checked="" type="checkbox"/> DIx (Digital Input)	<input checked="" type="checkbox"/> Overweight; <input checked="" type="checkbox"/> Brake Failure.
E34 Long Period at Torque Limitation <sup>(9)</sup>	<input checked="" type="checkbox"/> Power-on <input checked="" type="checkbox"/> Manual Reset (Key  ) <input checked="" type="checkbox"/> Auto Reset <input checked="" type="checkbox"/> DIx (Digital Input)	<input checked="" type="checkbox"/> The load was too heavy and the CFW-09 operated at torque limitation for a period longer than allowed. Failure on the brake opening caused the CFW-09 to operate at torque limitation for a period longer than allowed.
E41 Self Diagnosis Fault	Contact WEG (Refer to Section 7.3)	<input checked="" type="checkbox"/> Memory error or any internal inverter circuit defective.

Table 7.1 - Faults and possibles causes (cont.)

FAULT	RESET	POSSIBLE CAUSES
E70 Internal DC Supply Under Voltage <sup>(6)</sup>	<input checked="" type="checkbox"/> Power-on <input checked="" type="checkbox"/> Manual Reset (key  ) <input checked="" type="checkbox"/> Auto-reset <input checked="" type="checkbox"/> Dlx	<input checked="" type="checkbox"/> Phase loss at the R or S input. <input checked="" type="checkbox"/> Auxiliary circuit fuse blown (only valid for 500-690V and 660-690V models - see figure 3.7 f) g)).
E71 Watchdog error for the PLC board	<input checked="" type="checkbox"/> Power-on <input checked="" type="checkbox"/> Manual Reset (key  ) <input checked="" type="checkbox"/> Auto-reset <input checked="" type="checkbox"/> Dlx	<input checked="" type="checkbox"/> When the PLC board stops communicating with the CFW-09 for more than 200ms.

**Table 7.1 - Faults and possible causes (cont.)**

**Notes:**

**(1)** E03 Fault can occur only with:

- 220-230V Models with rated current equal or higher than 45 A;
- 380-480V Models with rated current equal or higher than 30 A;
- 500-600V Models with rated current equal or higher than 22 A;
- 500-690V Models;
- 660-690V Models;
- P214 set to 1.

**(2)** In case of E04 Fault due to inverter overtemperature, allow the inverter to cool before trying to reset it. The E04 fault code can also indicate a failure in the pre-charge circuit. But this is valid only for:

- 220-230V Models with rated current equal or higher than 70 A;
- 380-480V Models with rated current equal or higher than 86A.
- 500-690V Models with rated current equal or higher than 107A;
- 660-690V Models with rated current equal or higher than 1000A.

The failure in the pre-charge circuit means that the pre-charge contactor sizes up to 130A/220-230V, 142A/380-480V and 79A/500-600V) or pre-charge thyristor (sizes above 130A/220-230V, 142A/380-480V, 500-690V and 660-690V) is not closed, thus overheating the pre-charge resistors.

**(3)** For:

- 220-230V Models with rated current equal or higher than 16 A;
- 380-480V Models with rated current equal or higher than 13A, and equal or lower than 142A;
- 500-600V Models with rated current equal or higher than 12A, and equal or smaller than 79A;

E04 Fault can also be caused by internal airflow overtemperature. In this case, check the electronics blower.

**(4)** When E32 is displayed due to motor overtemperature, please allow the motor to cool down before restarting the inverter.

**(5)** When an incompatible parameter is programmed, a Fault Message – E24 - will be displayed and the LCD display will show a Help Message by indicating the Cause and how to correct the fault status.

**(6)** Only for models 107A to 472A/500-690V and 100A to 428A/660-690V.

**(7)** Long motor cables (longer than 100m (330ft)) can cause excessive capacitance to ground. This can cause nuisance E11 ground fault trips immediately after the inverter has been enabled.

**SOLUTION:**

- ☑ Reduce the switching frequency (P297).
- ☑ Connect a load reactor in series with the motor supply line. Refer to Section 8.8.

(8) This error occurs when the comparison  $[N = N^*]$  is greater than the maximum admissible error (set at P292) for a period longer than that set at P351. When P351=99.9 the detection logic for the error E33 is disabled. This error is only active in vector modes (P202=3 or 4).

(9) If the CFW-09 remains at torque limitation for a period longer than the value set at P352 the drive will trip with an error code E34. When P352=999 the detection logic for the error E34 is disabled. This error is only active in vector modes (P202=3 or 4).







**NOTE!**

When a fault occurs the following steps take place:

- ☑ E00 to E08, E10, E11, E12, E13, E15, E17, E32, E33, E34 and E71:
  - “No Fault” relay drops “out”;
  - PWM pulses are stopped;
  - The LED display indicates the fault code;
  - The LCD display indicates the fault code and description;
  - The “ERROR” LED flashes;
  - The following data is stored in the EEPROM:
    - Speed reference via Keypad or EP (Electronic Potentiometer), if the function “Reference Backup” is active (P120 set to 1 – On);
    - Fault code;
    - The status of the I x t function (motor overload);
    - The status of the powered time (P042) and Enabled Time (P043).
- ☑ E09:
  - Does not allow inverter operation.
- ☑ E24:
  - Indicates the code on the LED display plus and description on the LCD display;
  - It blocks the PWM pulses;
  - It does not permit motor driving;
  - It switches OFF the relay that has been programmed to “Without Error”;
  - It switches ON the relay that has been programmed to “With Error”.
- ☑ E31:
  - The inverter continues to operate normally;
  - It does not accept the Keypad commands;
  - The fault code is indicated on the LED display;
  - The LCD display indicates the fault code and description;
  - E31 is not stored in the fault memories (P014 to P017 and P060 to P065)
- ☑ E41:
  - Does not allow inverter operation;
  - The fault code is indicated on the LED display;
  - The LCD display indicates the fault code and description;
  - The “ERROR” LED flashes.

Indication of the inverter status LEDs:

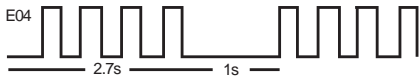
Led Power	Led Error	Description
		Inverter is powered up and is ready
	 (Flashing)	<p>A fault has been detected. The FAULT LED flashes, indicating the number of the Fault Code Exemple:</p>  <p>Note: If the fault E00 occurs, the ERROR LED is ON continuously.</p>

## 7.2 TROUBLESHOOTING

PROBLEM	POINT TO BE CHECKED	CORRECTIVE ACTION
Motor does not run	Incorrect Wiring	1. Check the power and control connections. For example the digital inputs DIX programmed for Start/Stop, General Enable and No External Fault must be connected to +24V. For factory default programming, XC1:1 (DI1) must be connected to +24V(XC1:9) and XC1:10 connected to XC1:8.
	Analog Reference (if used)	1. Check if the external signal is properly connected. 2. Check the status of the speed potentiometer (if used).
	Incorrect Programming	1. Check if the parameters are properly programmed for the application;
	Fault	1. Check if the inverter is not disabled due to a Fault condition (Refer to table above). 2. Check if there is a short-circuit between terminals XC1:9 and 10 (short-circuit at 24Vdc power supply).
	Motor Stall	1. Reduce the motor load. 2. Increase P169/P170 or P136/P137.

Table 7.2 - Troubleshooting

PROBLEM	POINT TO BE CHECKED	CORRECTIVE ACTION
Motor speed varies (oscillates)	Loose Connections	1. Disable the inverter, switch OFF the supply voltage and tighten all connections. 2. Check if all internal connection are tightened.
	Speed Potentiometer	1. Replace the speed potentiometer.
	Variation of the external analog reference	1. Identify the cause of the variation.
	Parameters not set correctly (for P202=3 or 4)	1. See Section 6, parameters P410, P412, P161, P162, P175 and P176.
Motor speed too high or too low	Programming error (reference limits)	1. Check if the contents of P133 (Min. Speed) and P134 (Max. Speed) are according to the motor and the application.
	Signal of the reference control	1. Check the control signal level of the reference. 2. Check the programming (gains and offset) in P234 to P247.
	Motor Nameplate	1. Check if the used motor meets the application requirements. Data
Motor does not reach rated speed or it starts to oscillate at rated speed for P202= 3 or 4 - Vector		1. Reduce P180 (set to 90 to 99%).
Display OFF	Connection of the Keypad	1. Check the Keypad connections to the inverter.
	Power Supply voltage	1. The power supply voltage must be within the following ranges: 220-230V power supply: - Min: 187V - Max: 253V 380-480V power supply: - Min: 323V - Max: 528V 500-600V power supply: - Min: 425V - Max: 660V 660-690V power supply: - Min: 561V - Max: 759V
	Blown Fuse(s)	1. Replace the fuse(s)
Motor does not enter the field weakening range (for P202= 3 or 4)		1. Set P180, between 90% and 99%
Motor speed too low and P009 = P169 or P170 (motor with torque limitation), for P202 = 4 - vector with encoder	Encoder signals or power connections	Check the signals A - $\bar{A}$ , B - $\bar{B}$ according to figure 8.7. If this connections are correct invert two output phases, for instance U and V. Refer to Figure 3.9.

Table 7.2 - Troubleshooting (cont.)

7.3 CONTACTING WEG



**NOTE!**

When contacting WEG for service or technical assistance, please have the following data on hand:

- ☑ Inverter Model;
- ☑ Serial number, manufacturing date and hardware revision, as indicated on the inverter nameplate (Refer to Section 2.4);
- ☑ Software Version (Refer to Section 2.2);
- ☑ Information about the application and inverter programming.

7.4 PREVENTIVE MAINTENANCE



**DANGER!**

Always disconnect the power supply voltage before touching any component of the inverter.

Even after switching OFF the inverter, high voltages may be present. Wait 10 minutes to allow complete discharge of the power capacitors.

Always connect the equipment frame to a suitable ground (PE) point.



**ATTENTION!**

Electronic boards have components sensitive to electrostatic discharges.

Never touch the components or connectors directly. If this is unavoidable, first touch the metallic frame or use a suitable ground strap.

**Never apply a high voltage test on the inverter!  
If this is necessary, contact WEG.**

To avoid operation problems caused by harsh ambient conditions, such as high temperature, moisture, dirt, vibration or premature aging of the components, periodic inspections of the inverter and installations are recommended.

COMPONENT	PROBLEMS	CORRECTIVE ACTIONS
Terminal blocks, connectors	Loose screws	Tighten them
	Loose connectors	
Blowers <sup>(1)</sup> / Cooling System	Blowers are dirty	Clean them
	Abnormal acoustic noise	Replace the blower
	Blower is not running	
	Abnormal vibration	
	Dust in the air filters	Clean or replace them
Printed circuit boards	Dust, oil or moisture accumulation	Clean them
	Smell	Replace them
Power module <sup>(3)</sup> / power connections	Dust, oil or moisture accumulation, etc.	Clean them
	Connection screws are loose	Tighten them
DC Bus Capacitors <sup>(2)</sup>	Discoloration / smell / electrolyte leakage	Replace them
	Safety valve is expanded or broken	
	Deformation	
Power resistor	Discoloration	Replace it
	Smell	

**Table 7.3 - Periodic Inspections after Start-up**

**Notes:**

- (1) It is recommended to replace the blowers after each 40,000 hours of operation;
- (2) Check the capacitors every six months. It is recommended to replace them after five years of operation.
- (3) If the inverter is stored for long periods, we recommend to power it up once a year during 1 hour. For 220-230V and 380-480V models apply supply voltage of approx. 220Vac, three-phase or single-phase input, 50 or 60 Hz, without connecting motor at output. After this energization, wait 24 hours before installing it. For 500-600V, 500-690V and 660-690V models use the same procedure applying a voltage between 300V and 330Vac to the inverter input.

### 7.4.1 Cleaning Instructions

When necessary clean the CFW-09 following the instructions below:

**Cooling system:**

- Remove AC power from the inverter and wait 10 minutes;
- Remove all dust from the ventilation openings by using a plastic bush or a soft cloth;
- Remove dust accumulated on the heat sink fins and from the blower blades with compressed air;

**Electronic Boards:**

- Remove AC power from the inverter and wait 10 minutes;
- Remove all dust from the printed circuit boards by using an anti-static soft brush or remove it with an ionized compressed air gun;
- If necessary, remove the PCBs from the inverter;
- Always use a ground strap.

7.5 SPARE PART LIST

Models 220-230V

Name	Item N°	Especification	Types (Ampères)							
			6	7	10	13	16	24	28	45
			Units per Inverter							
Fans	5000.5275	Fan 0400.3681 Length 255 mm (60x60)	1	1	1	1				
	5000.5292	Fan 0400.3679 Length 165 mm (40x40)					1	1	1	
	5000.5267	Fan 0400.3682 Length 200 mm (80x80)								2
	5000.5364	Fan 0400.3679 Length 230 mm (40x40)								1
	5000.5305	Fan 2x04003680 (60x60)					1	1	1	
Fuse	0305.6716	Fuse 6.3X32 3.15A 500V								1
HMI-CFW09-LCD	S417102024	HMI-LCD	1	1	1	1	1	1	1	1
CC9 - 00	S41509651	Control Board CC9.00	1	1	1	1	1	1	1	1
CFI1.00	S41509929	Interface Board with the HMI	1	1	1	1	1	1	1	1
DPS1.00	S41512431	Driver and Power Supply Board								1
CRP1.00	S41510960	Pulse Feedback Board	1	1	1	1	1	1	1	
KML-CFW09	S417102035	Kit KML	1	1						1
P06 - 2.00	S41512296	Power Board P06-2.00	1							
P07 - 2.00	S41512300	Power Board P07-2.00		1						
P10 - 2.00	S41512318	Power Board P10-2.00			1					
P13 - 2.00	S41512326	Power Board P13-2.00				1				
P16 - 2.00	S41512334	Power Board P16-2.00					1			
P24 - 2.00	S41512342	Power Board P24-2.00						1		
P28 - 2.00	S41512350	Power Board P28-2.00							1	
P45 - 2.00	S41510587	Power Board P45-2.00								1
HMI-CFW09-LED	S417102023	HMI-LED (Optional)	1	1	1	1	1	1	1	1
KMR-CFW09	S417102036	Kit KMR (Optional)	1	1	1	1	1	1	1	1
CFI1.01	S41510226	Interface Board with HMI (Optional)	1	1	1	1	1	1	1	1
EBA1.01	S41510110	Function Expansion Board (Optional)	1	1	1	1	1	1	1	1
EBA1.02	S41511761	Function Expansion Board (Optional)	1	1	1	1	1	1	1	1
EBA1.03	S41511770	Function Expansion Board (Optional)	1	1	1	1	1	1	1	1
EBB.01	S41510200	Function Expansion Board (Optional)	1	1	1	1	1	1	1	1
EBB.02	S41511788	Function Expansion Board (Optional)	1	1	1	1	1	1	1	1
EBB.03	S41511796	Function Expansion Board (Optional)	1	1	1	1	1	1	1	1
EBB.04	S41512671	Function Expansion Board (Optional)	1	1	1	1	1	1	1	1
EBB.05	S41512741	Function Expansion Board (Optional)	1	1	1	1	1	1	1	1
EBC1.01	S41513174	Function Expansion Board (Optional)	1	1	1	1	1	1	1	1
EBC1.02	S41513175	Function Expansion Board (Optional)	1	1	1	1	1	1	1	1
EBC1.03	S41513176	Function Expansion Board (Optional)	1	1	1	1	1	1	1	1
SCI1.00	S41510846	RS-232 Module for PC (Optional)	1	1	1	1	1	1	1	1
Modbus RTU	S03051277	Anybus-DT Modbus RTU Board (Optional)	1	1	1	1	1	1	1	1
Profibus DP	S03051269	Anybus-S Profibus DP Board (Optional)	1	1	1	1	1	1	1	1
DeviceNet	S03051250	Anybus-S DeviceNET Board (Optional)	1	1	1	1	1	1	1	1

Models 220-230V

Name	Item N°	Especification	Types (Ampères)				
			54	70	86	105	130
			Units per Inverter				
Precharge	035502345	Cont.CWM32.10 220V 50/60 Hz		1	1		
Contactors	035502394	Cont.CWM50.00 220V 50/60 Hz				1	1
Precharge Resistor	0301.1852	Vitrified wire Resistor 20R 75 W		1	1	1	1
Fan	5000.5267	Fan 0400.3682 Length.200 mm	2				
	5000.5127	Fan 0400.3682 Length 285 mm	1				
	5000.5208	Fan 0400.3683 Lenght 230mm (120x120)		1	1		
	5000.5364	Fan 0400.3679 Length. 230mm (40x40)	1	1	1	1	1
	5000.5216	Fan 0400.3683 Length 330mm		1	1		
	0400.2547	Fan 220V 50/60Hz				1	1
Fuse	0305.6716	Fuse 6.3x32 3.15A 500V	1	1	1	1	1
	0305.5604	Ret Fuse 0.5A 600V FNQ-R1		2	2	2	2
HMI-CFW09-LCD	S417102024	HMI LCD	1	1	1	1	1
CC9.00	S41509651	Control Board CC9.00	1	1	1	1	1
LVS1.01	S41510927	Board LVS1.01		1	1	1	1
CFI1.00	S41509929	Interface Board with the HMI	1	1	1	1	1
DPS1.00	S41512431	Power Supplies and Firing Board	1				
KML-CFW09	S417102035	Kit KML	1	1	1	1	1
DPS1.01	S41512440	Driver and Power Supply Board		1	1	1	1
*P54 - 2.00	S41510552	Power Board P54-2.00	1				
P54 - 2.01	S41511443	Power Board P54-2.01	1				
*P70 - 2.00	S41511354	Power Board P70-2.00		1			
P70 - 2.01	S41511451	Power Board P70-2.01		1			
*P86 - 2.00	S41510501	Power Board P86-2.00			1		
P86 - 2.01	S41511460	Power Board P86-2.01			1		
*P105 - 2.00	S41511362	Power Board P105-2.00				1	
P105 - 2.01	S41511478	Power Board P105-2.01				1	
*P130 - 2.00	S41510439	Power Board P130-2.00					1
P130 - 2.01	S41511486	Power Board P130-2.01					1
HMI-CFW09-LED	S417102023	HMI LED (Optional)	1	1	1	1	1
KMR-CFW09	S417102036	Kit KMR (Optional)	1	1	1	1	1
CFI1.01	S41510226	Interface Board with HMI (Optional)	1	1	1	1	1
EBA1.01	S41510110	Function Expansion Board (Optional)	1	1	1	1	1
EBA1.02	S41511761	Function Expansion Board (Optional)	1	1	1	1	1
EBA1.03	S41511770	Function Expansion Board (Optional)	1	1	1	1	1
EBB.01	S41510200	Function Expansion Board (Optional)	1	1	1	1	1
EBB.02	S41511788	Function Expansion Board (Optional)	1	1	1	1	1
EBB.03	S41511796	Function Expansion Board (Optional)	1	1	1	1	1
EBB.04	S41512671	Function Expansion Board (Optional)	1	1	1	1	1
EBB.05	S41512741	Function Expansion Board (Optional)	1	1	1	1	1
EBC1.01	S41513174	Funcion Expacion Board (Optional)	1	1	1	1	1
EBC1.02	S41513175	Function Expansion Board (Optional)	1	1	1	1	1
EBC1.03	S41513176	Function Expansion Board (Optional)	1	1	1	1	1
SCI1.00	S41510846	RS-232 module for PC (Optional)	1	1	1	1	1
Modbus RTU	S03051277	Anybus-DT Modbus RTU Board (Optional)	1	1	1	1	1
Profibus DP	S03051269	Anybus-S Profibus DP Board (Optional)	1	1	1	1	1
DeviceNet	S03051250	Anybus-S DeviceNET Board (Optional)	1	1	1	1	1
Current Transformer	0307.2495	Current transformer 200A/100mA				2	2

\* Only the types specified with braking (DB)

## CHAPTER 7 - DIAGNOSTICS AND TROUBLESHOOTING

### Models 380-480V

Name	Item N°	Especification	Type (Ampères)							
			3.6	4	5.5	9	13	16	24	30
			Units per Inverter							
Fans	5000.5275	Fan 0400.3284 Length 190 mm (60x60)	1	1	1	1				
	5000.5305	Fan 2x0400.2423 150/110 mm (60x60)					1	1		
	5000.5292	Fan 0400.3679 Length 165 mm (40x40)					1	1	1	
	5000.5283	Fan 2x0400.3681 (135/175) mm (60x60)							1	
	5000.5259	Fan 0400.3682 Length 140 mm (80x80)								2
	5000.5364	Fan 0400.3679 Length 230 mm (40x40)								1
Fuse	0305.6716	Fuse 6.3x32 3.15A 500V								1
CC9.00	S41509651	Control Board CC9.00	1	1	1	1	1	1	1	1
HMI-CFW09-LCD	S417102024	HMI LCD	1	1	1	1	1	1	1	1
CFI1.00	S41509929	Interface Board with HMI	1	1	1	1	1	1	1	1
DPS1.00	S41512431	Driver and Power Supply Board								1
CRP1.01	S41510820	Pulse Feedback Board	1	1	1	1	1	1	1	
KML-CFW09	S417102035	Kit KML								1
P03 - 4.00	S41512369	Power Board P03-4.00	1							
P04 - 4.00	S41512377	Power Board P04-4.00		1						
P05 - 4.00	S41512385	Power Board P05-4.00			1					
P09 - 4.00	S41512393	Power Board P09-4.00				1				
P13 - 4.00	S41512407	Power Board P13-4.00					1			
P16 - 4.00	S41512415	Power Board P16-4.00						1		
P24 - 4.00	S41512423	Power Board P24-4.00							1	
P30 - 4.00	S41509759	Power Board P30-4.00								1
HMI-CFW09-LED	S417102023	HMI LED (Opcional)	1	1	1	1	1	1	1	1
KMR-CFW09	S417102036	Kit KMR (Optional)	1	1	1	1	1	1	1	1
CFI1.01	S41510226	Interface Board with HMI (Optional)	1	1	1	1	1	1	1	1
EBA1.01	S41510110	Function Expansion Board (Optional)	1	1	1	1	1	1	1	1
EBA1.02	S41511761	Function Expansion Board (Optional)	1	1	1	1	1	1	1	1
EBA1.03	S41511770	Function Expansion Board (Optional)	1	1	1	1	1	1	1	1
EBB.01	S41510200	Function Expansion Board (Optional)	1	1	1	1	1	1	1	1
EBB.02	S41511788	Function Expansion Board (Optional)	1	1	1	1	1	1	1	1
EBB.03	S41511796	Function Expansion Board (Optional)	1	1	1	1	1	1	1	1
EBB.04	S41512671	Function Expansion Board (Optional)	1	1	1	1	1	1	1	1
EBB.05	S41512741	Function Expansion Board (Optional)	1	1	1	1	1	1	1	1
EBC1.01	S41513174	Funcion Expancion Board (Optional)	1	1	1	1	1	1	1	1
EBC1.02	S41513175	Function Expansion Board (Optional)	1	1	1	1	1	1	1	1
EBC1.03	S41513176	Function Expansion Board (Optional)	1	1	1	1	1	1	1	1
SCI1.00	S41510846	RS-232 Module for PC (Optional)	1	1	1	1	1	1	1	1
Modbus RTU	S03051277	Anybus-DT Modbus RTU Board (Optional)	1	1	1	1	1	1	1	1
Profibus DP	S03051269	Anybus-S Profibus DP Board (Optional)	1	1	1	1	1	1	1	1
DeviceNet	S03051250	Anybus-S DeviceNET Board (Optional)	1	1	1	1	1	1	1	1

Models 380-480V

Name	Item N°	Especification	Type (Ampères)						
			38	45	60	70	86	105	142
			Units per inverter						
Precharge Contactor	035502394	Contacteur CWM50.10 220V 50/60 Hz					1	1	1
Precharge Transfor	0307.0034	Transformer 100 VA					1	1	
	0307.0042	Transformer 300 VA							1
Precharge Resistor	0301.1852	Vitrified wire Resistor 20R 75 W					1	1	1
Fans	5000.5267	Fan 0400.3682 Length.200 mm (80x80)	3	3					
	5000.5208	Fan 0400.3683 Length 230 mm (120x120)			1	1			
	5000.5216	Fan 0400.3683 Length 330mm (40x40)			1	1			
	5000.5364	Fan 0400.3679 Length230 mm (40x40)	1	1	1	1	1	1	1
	0400.2547	Fan 220V 50/60Hz					1	1	
Fuse	0305.5604	Ret. Fuse 0.5A 600V FNQ-R1					2	2	
	0305.5663	Ret. Fuse 1.6A 600V							2
	0305.6716	Fuse 6.3x32 3.15A 500V	1	1	1	1	1	1	1
HMI-CFW09-LCD	S417102024	HMI LCD	1	1	1	1	1	1	1
CC9.00	S41509651	Controle Board CC9.00	1	1	1	1	1	1	1
CFI1.00	S41509929	HMI Interface Board	1	1	1	1	1	1	1
DPS1.00	S41512431	Driver and Power Supply Board	1	1					
DPS1.01	S41512440	Driver and Power Supply Board			1	1	1	1	1
LVS1.00	S41510269	Voltage Selection Board					1	1	1
CB1.00	S41509996	Board CB1.00			2	2			
CB3.00	S41510285	Board CB3.00					2	2	2
KML-CFW09	S417102035	Kit KML	1	1	1	1	1	1	1
*P38-4.00	S41511753	Power Board P38-4.00	1						
P38-4.01	S41511370	Power Board P38-4.01	1						
*P45-4.00	S41509805	Power Board P45-4.00		1					
P45-4.01	S41511389	Power Board P45-4.01		1					
*P60-4.00	S41511338	Power Board P60-4.00			1				
P60-4.01	S41511397	Power Board P60-4.01			1				
*P70-4.00	S41509970	Power Board P70-4.00				1			
P70-4.01	S41511400	Power Board P70-4.01				1			
*P86-4.00	S41511346	Power Board P86-4.00					1		
P86-4.01	S41511419	Power Board P86-4.01					1		
*P105-4.00	S41509953	Power Board P105-4.00						1	
P105-4.01	S41511427	Power Board P105-4.01						1	
*P142-4.00	S41510056	Power Board P142-4.00							1
P142-4.01	S41511435	Power Board P142-4.01							1
HMI-CFW09-LED	S417102023	HMI LED (Optional)	1	1	1	1	1	1	1
KMR-CFW09	S417102036	Kit KMR (Optional)	1	1	1	1	1	1	1
CFI1.01	S41510226	Interface Board with HMI (Optional)	1	1	1	1	1	1	1
EBA1.01	S41510110	Function Expansion Board (Optional)	1	1	1	1	1	1	1
EBA1.02	S41511761	Function Expansion Board (Optional)	1	1	1	1	1	1	1
EBA1.03	S41511770	Function Expansion Board (Optional)	1	1	1	1	1	1	1
EBB.01	S41510200	Function Expansion Board (Optional)	1	1	1	1	1	1	1
EBB.02	S41511788	Function Expansion Board (Optional)	1	1	1	1	1	1	1
EBB.03	S41511796	Function Expansion Board (Optional)	1	1	1	1	1	1	1
EBB.04	S41512671	Function Expansion Board (Optional)	1	1	1	1	1	1	1
EBB.05	S41512741	Function Expansion Board (Optional)	1	1	1	1	1	1	1

## CHAPTER 7 - DIAGNOSTICS AND TROUBLESHOOTING

Name	Item N°	Especification	Type (Ampères)						
			38	45	60	70	86	105	142
			Units per inverter						
EBC1.01	S41513174	Funcion Expacion Board (Optional)	1	1	1	1	1	1	1
EBC1.02	S41513175	Function Expansion Board (Optional)	1	1	1	1	1	1	1
EBC1.03	S41513176	Function Expansion Board (Optional)	1	1	1	1	1	1	1
CB7D.00	S41513136	Board CB7D.00			1	1			
CB7E.00	S41513134	Board CB7E.00			1	1			
CB4D.00	S41513058	Board CB4D.00					1	1	1
CB4E.00	S41513107	Board CB4E.00					1	1	1
SCI1.00	S41510846	RS-232 Module for PC (Optional)	1	1	1	1	1	1	1
Modbus RTU	S03051277	Anybus-DT Modbus RTU Board (Optional)	1	1	1	1	1	1	1
Profibus DP	S03051269	Anybus-S Profibus DP Board (Optional)	1	1	1	1	1	1	1
DeviceNet	S03051250	Anybus-S DeviceNET Board (Optional)	1	1	1	1	1	1	1
Current Trasformer	0307.2495	Current transformer 200A/100mA					2	2	2

\*Only for the types specified with braking (DB)

### Models 380-480V

Name	Item N°	Especification	Type (Ampères)							
			180	211	240	312	361	450	515	600
			Units per inverter							
IGBT Module	0303.7118	IGBT Module 200A 1200V	6							
	0298.0001	IGBT Module 300A 1200V - (EUPEC)		6	6					
	0303.9315	IGBT Module 300A 1200V				6	6	9	12	12
Inverter Arm	417102497	Inverter Arm 361A - EP				3	3			
	417102498	Inverter Arm 450A - EP						3		
	417102499	Inverter Arm 600A - EP							3	3
	417102496	InverterArm 600A				6	6	9	12	12
Thyristor-Diode Module	0298.0016	Thyristor-Diode Module TD330N16				3	3			
	0303.9986	Thyristor-Diode Module TD425N16						3		
	0303.9994	Thyristor-Diode Module TD500N16							3	3
	0298.0003	Thyristor-Diode Module SKKH 250/16	3	3	3					
Precharge Transformer	0307.0204	Transformer of Fan and SCR Firing Pulse 250VA	1	1	1					
	0307.0212	Transformer of Fan and SCR Firing Pulse 650VA				1	1	1	1	1
Precharge Resistor	0301.9250	Vitrified Wire Resistor 35 R 75 W	6	6	6	8	8	10	10	10
Rectifier Bridge	0303.9544	Three-Phase Rectifier Bridge 35A 1400V	1	1	1	1	1	1	1	1
Electrolytic Capacitor	0302.4873	Electrolytic Capacitor 4700uF/400V	8	12	12	18	18	24	30	30
Fan	6431.3207	Centrifugal Fan 230V 50/60Hz	1	1	1	3	3	3	3	3
Fuses	0305.5663	Ret. Fuse 1.6A 600V	2	2	2					
	0305.6112	Ret. Fuse 2.5A 600V				2	2	2	2	2
HMI-CF09-LCD	S417102024	HMI LCD	1	1	1	1	1	1	1	1
KML-CF09	S417102035	Kit KML	1	1	1	1	1	1	1	1
CC9.00	S41509651	Control Board CC9.00	1	1	1	1	1	1	1	1
DPS2.00	S41510897	Driver and Power Supply Board DPS2.00	1	1	1	1	1			
DPS2.01	S41511575	Driver and Power Supply Board DPS2.01						1	1	1
CRG2.00	S41512615	Gate Resistor Board CRG2X.00	3	3	3	3	3			
CRG3X.01	S41512618	Gate Resistor Board CRG3X.01						3		
CRG3X.00	S41512617	Gate Resistor Board CRG3X.00							3	3
CIP2.00	S41513217	CIP2A.00 Board	1							
CIP2.01	S41513218	CIP2A.01 Board			1					

Name	Item N°	Especification	Type (Ampères)							
			180	211	240	312	361	450	515	600
			Units per inverter							
CIP2.02	S41513219	CIP2A.02 Board					1			
CIP2.03	S41513220	CIP2A.03 Board						1		
CIP2.04	S41513221	CIP2A.04 Board								1
CIP2.52	S41513228	CIP2A.52 Board		1						
CIP2.53	S41513229	CIP2A.53 Board				1				
CIP2.54	S41513230	CIP2A.54 Board							1	
SKHI23MEC8	S41511532	Board SKHI23/12 for MEC8	3	3	3					
SKHI23MEC10	S41511540	Board SKHI23/12 for MEC10				3	3	3		
HMI-CFW09-LED	S417102023	HMI LED (Optional)	1	1	1	1	1	1	1	1
KMR-CFW09	S417102036	Kit KMR (Optional)	1	1	1	1	1	1	1	1
CFI1.01	S41510226	Interface Board with HMI (Optional)	1	1	1	1	1	1	1	1
EBA1.01	S41510110	Function Expansion Board (Optional)	1	1	1	1	1	1	1	1
EBA1.02	S41511761	Function Expansion Board (Optional)	1	1	1	1	1	1	1	1
EBA1.03	S41511770	Function Expansion Board (Optional)	1	1	1	1	1	1	1	1
EBB.01	S41510200	Function Expansion Board (Optional)	1	1	1	1	1	1	1	1
EBB.02	S41511788	Function Expansion Board (Optional)	1	1	1	1	1	1	1	1
EBB.03	S41511796	Function Expansion Board (Optional)	1	1	1	1	1	1	1	1
EBB.04	S41512671	Function Expansion Board (Optional)	1	1	1	1	1	1	1	1
EBB.05	S41512741	Function Expansion Board (Optional)	1	1	1	1	1	1	1	1
EBC1.01	S41513174	Function Expansion Board (Optional)	1	1	1	1	1	1	1	1
EBC1.02	S41513175	Function Expansion Board (Optional)	1	1	1	1	1	1	1	1
EBC1.03	S41513176	Function Expansion Board (Optional)	1	1	1	1	1	1	1	1
SCI1.00	S41510846	RS-232 Module for PC (Optional)	1	1	1	1	1	1	1	1
Modbus RTU	S03051277	Anybus-DT Modbus RTU Board (Optional)	1	1	1	1	1	1	1	1
Profibus DP	S03051269	Anybus-S Profibus DP Board (Optional)	1	1	1	1	1	1	1	1
DeviceNet	S03051250	Anybus-S DeviceNETBoard (Optional)	1	1	1	1	1	1	1	1
Current Transducers	0307.2509	Current Transformer 500A/250mA	2	2	2					
	0307.2550	Current Transformer 5000A/1A LT SI							2	2
	0307.2070	Current Transformer 1000A/200mA LT 100SI				2	2	2		

Models 500-600V

Name	Item N°	Especification	Types (Ampères)					
			2.9	4.2	7	10	12	14
			Units per Inverter					
Fans	5000.5291	Fan 0400.3217 Comp. 145mm (40x40)	1	1	1	1	1	1
	5000.5435	Fan 2x400.3284 290/200mm (60x60)			1	1	1	1
CC9.00	S41509651	Control Board CC9.00	1	1	1	1	1	1
HMI-CFW09-LCD	S417102024	HMI LCD	1	1	1	1	1	1
CIF1.00	S41509929	Interface Board with HMI	1	1	1	1	1	1
CRP2.00	S41512862	Pulse Feedback Board	1	1	1	1	1	1
P02-6.00	S41512855	Power Board P02-6.00	1					
P04-6.00	S41512856	Power Board P04-6.00		1				
P07-6.00	S41512857	Power Board P04-6.00			1			
P10-6.00	S41512858	Power Board P10-6.00				1		
P12-6.00	S41512859	Power Board P12-6.00					1	
P14-6.00	S41512860	Power Board P14-6.00						1

## CHAPTER 7 - DIAGNOSTICS AND TROUBLESHOOTING

Name	Item N°	Especificacion	Types (Ampères)					
			2.9	4.2	7	10	12	14
			Units per Inverter					
HMI-CFW09-LED	S417102023	HMI LED (Optional)	1	1	1	1	1	1
KMR-CFW09	S417102036	Kit KMR (Optional)	1	1	1	1	1	1
CIF1.01	S41510226	Interface Board with HMI (Optional)	1	1	1	1	1	1
EBA1.01	S41510110	Function Expansion Board (Optional)	1	1	1	1	1	1
EBA1.02	S41511761	Function Expansion Board (Optional)	1	1	1	1	1	1
EBA1.03	S41511770	Function Expansion Board (Optional)	1	1	1	1	1	1
EBB.01	S41510200	Function Expansion Board (Optional)	1	1	1	1	1	1
EBB.02	S41511788	Function Expansion Board (Optional)	1	1	1	1	1	1
EBB.03	S41511796	Function Expansion Board (Optional)	1	1	1	1	1	1
EBB.04	S41512671	Function Expansion Board (Optional)	1	1	1	1	1	1
EBB.05	S41512741	Function Expansion Board (Optional)	1	1	1	1	1	1
EBC1.01	S41513174	Funcion Expanscion Board (Optional)	1	1	1	1	1	1
EBC1.02	S41513175	Function Expansion Board (Optional)	1	1	1	1	1	1
EBC1.03	S41513176	Function Expansion Board (Optional)	1	1	1	1	1	1
SCI1.00	S41510846	RS-232 Module for PC (Optional)	1	1	1	1	1	1
Modbus RTU	S03051277	Anybus-DT Modbus RTU Board (Optional)	1	1	1	1	1	1
Profibus DP	S03051269	Anybus-S Profibus DP Board (Optional)	1	1	1	1	1	1
DeviceNet	S03051250	Anybus-S DeviceNet Board (Optional)	1	1	1	1	1	1

### Models 500-600V

Name	Item N°	Especificacion	Types (Ampères)		
			22	27	32
			Units per Inverter		
Fans	5000.5267	Fan 0400.2482 Comp. 150mm (80x80)	3	3	3
Fuse	0305.6716	Fuse 6.3x32 3.15A 500V	1	1	1
CC9.00	S41509651	Control Board CC9.00	1	1	1
HMI-CFW09-LCD	S417102024	HMI LCD	1	1	1
CIF1.00	S41509929	Interface Board with HMI	1	1	1
KML-CFW09	S417102035	Kit KML	1	1	1
DPS4.00	S41512864	Driver and Power Supply Board	1	1	1
P22-6.01	S41512867	Power Board P22-6.01	1		
P22-6.00	S41512866	Power Board P22-6.00	1		
P27-6.01	S41512869	Power Board P27-6.01		1	
*P27-6.00	S41512868	Power Board P27-6.00		1	
P32-6.01	S41512872	Power Board P32-6.01			1
*P32-6.00	S41512871	Power Board P32-6.00			1
HMI-CFW09-LED	S417102023	HMI LED (Optional)	1	1	1
KMR-CFW09	S417102036	Kit KMR (Optional)	1	1	1
CIF1.01	S41510226	Interface Board with HMI (Optional)	1	1	1
EBA1.01	S41510110	Function Expansion Board (Optional)	1	1	1
EBA1.02	S41511761	Function Expansion Board (Optional)	1	1	1
EBA1.03	S41511770	Function Expansion Board (Optional)	1	1	1
EBB.01	S41510200	Function Expansion Board (Optional)	1	1	1
EBB.02	S41511788	Function Expansion Board (Optional)	1	1	1
EBB.03	S41511796	Function Expansion Board (Optional)	1	1	1

Models 500-600V

Name	Item N°	Especificacion	Types (Ampères)		
			22	27	32
			Units per Inverter		
EBB.04	S41512671	Function Expansion Board (Optional)	1	1	1
EBB.05	S41512741	Function Expansion Board (Optional)	1	1	1
EBC1.01	S41513174	Funcion Expacion Board (Optional)	1	1	1
EBC1.02	S41513175	Function Expansion Board (Optional)	1	1	1
EBC1.03	S41513176	Function Expansion Board (Optional)	1	1	1
SCI1.00	S41510846	RS-232 Module for PC (Optional)	1	1	1
Modbus RTU	S03051277	Anybus-DT Modbus RTU Board (Optional)	1	1	1
Profibus DP	S03051269	Anybus-S Profibus DP Board (Optional)	1	1	1
DeviceNet	S03051250	Anybus-S DeviceNet Board (Optional)	1	1	1

\* Only for types specified with braking (DB).

Models 500-600V

Name	Item N°	Especificacion	Types (Ampères)			
			44	53	63	79
			Units per Inverter			
Precharge Contactor	035506138	Contactora CWM50.00 220V 50/60Hz	1	1	1	1
PrechargeTransform	0299.0160	Preload Transformer	1	1	1	1
Precharge Resistor	0301.1852	Vetrified Wire Resistor 20R 75W	1	1	1	1
Fan	0400.2547	Fan 220V 50/60Hz	1	1	1	1
Fuse	0305.6166	Fuse 14x51mm 2A 690V	2	2	2	2
HMI-CFW09-LCD	S417102024	HMI LCD	1	1	1	1
CC9	S41509651	Control Board CC9	1	1	1	1
CFI1.00	S41509929	HMI Interface Board	1	1	1	1
DPS5.00	S41512966	Driver and Power Supply Board DPS5.00	1	1	1	1
LVS2.00	S41512990	Voltage Selection Board LVS2.00	1	1	1	1
CB5D.00	S41512986	Board CB5D.00				1
CB5E.00	S41413063	CB5E.00 Board		1	1	
CB5E.01	S41413081	CB5E.01 Board				1
KML-CFW09	S417102035	Kit KML	1	1	1	1
*P44-6.00	S41512968	Power Board P44-6.00	1			
P44-6.01	S41512969	Power Board P44-6.01	1			
*P53-6.00	S41512973	Power Board P53-6.00		1		
P53-6.01	S41512974	Power Board P53-6.01		1		
*P63-6.00	S41512975	Power Board P63-6.00			1	
P63-6.01	S41512976	Power Board P63-6.01			1	
*P79-6.00	S41512977	Power Board P79-6.00				1
P79-6.01	S41512978	Power Board P79-6.01				1
HMI-CFW09-LED	S417102023	HMI LED (Optional)	1	1	1	1
KMR-CFW09	S417102036	Kit KMR (Optional)	1	1	1	1
CFI1.01	S41510226	HMI Interface Board (Optional)	1	1	1	1
EBA1.01	S41510110	Function Expansion Board (Optional)	1	1	1	1
EBA1.02	S41511761	Function Expansion Board (Optional)	1	1	1	1
EBA1.03	S41511770	Function Expansion Board (Optional)	1	1	1	1

**CHAPTER 7 - DIAGNOSTICS AND TROUBLESHOOTING**

Name	Item N°	Especificacion	Types (Ampères)			
			44	53	63	79
			Units per Inverter			
EBB.04	S41512671	Function Expansion Board (Optional)	1	1	1	1
EBB.05	S41512741	Function Expansion Board (Optional)	1	1	1	1
EBC1.01	S41513174	Funcion Expacion Board (Optional)	1	1	1	1
EBC1.02	S41513175	Function Expansion Board (Optional)	1	1	1	1
EBC1.03	S41513176	Function Expansion Board (Optional)	1	1	1	1
SCI1.00	S41510846	RS-232 Module for PC (Optional)	1	1	1	1
Modbus RTU	S03051277	Anybus-DT Modbus RTU Board (Optional)	1	1	1	1
Profibus DP	S03051269	Anybus-S Profibus DP Board (Optional)	1	1	1	1
DeviceNet	S03051250	Anybus-S DeviceNet Board (Optional)	1	1	1	1
DC Link Inductor	0299.0156	DC Link Inductor 749 µH	1			
DC Link Inductor	0299.0157	DC Link Inductor 562 µH		1		
DC Link Inductor	0299.0158	DC Link Inductor 481µH			1	
DC Link Inductor	0299.0159	DC Link Inductor 321µH				1

\* Only for types specified with braking (DB).

**Models 500-690V**

Name	Item N°	Especificacion	Types (Ampères)							
			107	147	211	247	315	343	418	472
			Units per inverter							
IGBT Module	0298.0008	IGBT Module 200A 1700V		6						
	0298.0009	IGBT Module 300A 1700V	3		6	6	9	9	12	12
Inverter Arm	S417104460	Inverter Arm 247A – EP				3				
	S417104461	Inverter Arm 315A – EP					3			
	S417104462	Inverter Arm 343A – EP						3		
	S417104463	Inverter Arm 418A – EP							3	
	S417104464	Inverter Arm 472A – EP								3
Thyristor-Diode Module	0303.9978	Thyristor-Diode Module TD250N16	3	3	3	3	3	3		
	0303.9986	Thyristor-Diode Module TD425N16							3	
	0303.9994	Thyristor-Diode Module TD500N16								3
Rectifier Bridge	0298.0026	Rectifier Bridge 36MT160	1	1	1	1	1	1	1	1
Precharge Resistor	0301.9250	Vitrified Wire Resistor 35R 75W	6	6	6	8	8	8	8	10
Fan	64313207	Centrifugal Fan 230V 50/60Hz	1	1	1	3	3	3	3	3
Electrolytic Capacitor	0302.4873	Electrolytic Capacitor 4700uF/400V	9	12	12	18	18	18		
	0302.4801	Electrolytic Capacitor 4700uF/400V							18	27
Fuse	0305.6166	Fuse2A 690V	2	2	2					
	0305.6171	Fuse 4 690V				2	2	2	2	2
HMI-CFW09-LCD	S417102024	HMI LCD	1	1	1	1	1	1	1	1
KML-CFW09	S417102035	Kit KML	1	1	1	1	1	1	1	1
CC9	S41509651	Control Board CC9	1	1	1	1	1	1	1	1
DPS3	S41512834	Driver and Power Supply Board DPS3.00	1	1	1	1	1	1	1	1
CRG7	S41512951	Gate Resistor Board CRG7.00	3	3	3	3				
CRG6	S41512798	Gate Resistor Board CRG6.00					3	3	3	3
FCB1.00	S41512821	Board FCB1.00				3	3	3	3	3
FCB1.01	S41512999	Board FCB1.01				3	3	3	3	3
FCB2	S41513011	Board FCB2.00	1	1	1					
CIP3	S41512803	Board CIP3.00	1	1	1	1	1	1	1	1

Name	Item N°	Especification	Types (Ampères)							
			107	147	211	247	315	343	418	472
			Units per inverter							
RCS3	S41512846	Rectifier Snubber Board RCS3.00							3	3
CIS1	S41512836	Signal Interface Board CIS1.00	1							
	S41512883	Signal Interface Board CIS1.01		1						
	S41512884	Signal Interface Board CIS1.02			1					
	S41512885	Signal Interface Board CIS1.03				1				
	S41512886	Signal Interface Board CIS1.04					1			
	S41512887	Signal Interface Board CIS1.05						1		
	S41512888	Signal Interface Board CIS1.06							1	
	S41512889	Signal Interface Board CIS1.07								1
GDB1.00	S41512963	Gate Driver Board GDB1.00	3	3	3	3	3	3	3	3
HMI-CFW09-LED	S417102023	HMI LED (Optional)	1	1	1	1	1	1	1	1
KMR-CFW09	S417102036	Kit KMR (Optional)	1	1	1	1	1	1	1	1
CFI1.01	S41510226	Interface board with HMI (Optional)	1	1	1	1	1	1	1	1
EBA1.01	S41510110	Function Expansion Board (Optional)	1	1	1	1	1	1	1	1
EBA1.02	S41511761	Function Expansion Board (Optional)	1	1	1	1	1	1	1	1
EBA1.03	S41511770	Function Expansion Board (Optional)	1	1	1	1	1	1	1	1
EBB.01	S41510200	Function Expansion Board (Optional)	1	1	1	1	1	1	1	1
EBB.02	S41511788	Function Expansion Board (Optional)	1	1	1	1	1	1	1	1
EBB.03	S41511796	Funcion Expansion Board (Optional)	1	1	1	1	1	1	1	1
EBB.04	S41512671	Function Expansion Board (Optional)	1	1	1	1	1	1	1	1
EBB.05	S41512741	Function Expansion Board (Optional)	1	1	1	1	1	1	1	1
EBC1.01	S41513174	Funcion Expansion Board (Optional)	1	1	1	1	1	1	1	1
EBC1.02	S41513175	Function Expansion Board (Optional)	1	1	1	1	1	1	1	1
EBC1.03	S41513176	Function Expansion Board (Optional)	1	1	1	1	1	1	1	1
SCI1.00	S41510846	RS-232 Module for PC (Optional)	1	1	1	1	1	1	1	1
Modbus RTU	S03051277	Anybus-DT Modbus RTU Board (Optional)	1	1	1	1	1	1	1	1
Profibus DP	S03051269	Anybus-S Profibus DP Board (Optional)	1	1	1	1	1	1	1	1
DeviceNet	S03051250	Anybus-S DeviceNet Board (Optional)	1	1	1	1	1	1	1	1

Models 660-690V

Name	Item N°	Especification	Types (Ampères)							
			100	127	179	225	259	305	340	428
			Units per Inverter							
IGBT Module	0298.0008	IGBT Module 200A 1700V		6						
	0298.0009	IGBT Module 300A 1700V	3		6	6	9	9	12	12
Inverter Arm	S417104460	Inverter Arm 225A – EP				3				
	S417104461	Inverter Arm 259A – EP					3			
	S417104462	Inverter Arm 305A – EP						3		
	S417104463	Inverter Arm 340A – EP							3	
	S417104464	Inverter Arm 428A – EP								3
Thyristor-Diode Module	0303.9978	Thyristor-Diode Module TD250N16	3	3	3	3	3	3		
	0303.9986	Thyristor-Diode Module TD425N16							3	
	0303.9994	Thyristor-Diode Module TD500N16								3
Rectifier Bridge	0298.0026	Rectifier Bridge 36MT160	1	1	1	1	1	1	1	1
Precharge Resistor	0301.9250	Vitrified Wire Resistor 35R 75W	6	6	6	8	8	8	8	10

**CHAPTER 7 - DIAGNOSTICS AND TROUBLESHOOTING**

Name	Item N°	Especification	Types (Ampères)							
			100	127	179	225	259	305	340	428
			Units per Inverter							
Fan	6431.3207	Centrifugal Fan 230V 50/60Hz	1	1	1	3	3	3	3	3
Electrolytic Capacitor	0302.4873	Electrolytic Capacitor 4700uF/400V	9	12	12	18	18	18		
	0302.4801	Electrolytic Capacitor 4700uF/400V							18	27
Fuse	0305.6166	Fuse 2A 690V	2	2	2					
	0302.6171	Fuse 4 690V				2	2	2	2	2
HMI-CFW09-LCD	S417102024	HMI LCD	1	1	1	1	1	1	1	1
KML-CFW09	S417102035	Kit KML	1	1	1	1	1	1	1	1
CC9	S41509651	Control Board CC9	1	1	1	1	1	1	1	1
DPS3	S41512834	Driver and Power Supply Board DPS3.00	1	1	1	1	1	1	1	1
CRG7	S41512951	Gate Resistor Board CRG7.00	3	3	3	3				
CRG6	S41512798	Gate Resistor Board CRG6.00					3	3	3	3
	S41512821	Board FCB1.00				3	3	3	3	3
FCB1	S41512999	Board FCB1.01				3	3	3	3	3
FCB2	S41513011	Board FCB2.00	1	1	1					
CIP3	S41512803	Board CIP3.00	1	1	1	1	1	1	1	1
RCS3	S41512846	Rectifier Snubber Board RCS3.00							3	3
CIS1	S41512890	Signal Interface Board CIS1.08	1							
	S41512891	Signal Interface Board CIS1.09		1						
	S41512892	Signal Interface Board CIS1.10			1					
	S41512893	Signal Interface Board CIS1.11				1				
	S41512894	Signal Interface Board CIS1.12					1			
	S41512895	Signal Interface Board CIS1.13						1		
	S41512896	Signal Interface Board CIS1.14							1	
	S41512897	Signal Interface Board CIS1.15								1
GDB1.00	S41512963	Gate Driver Board GDB1.00	3	3	3	3	3	3	3	3
HMI-CFW09-LED	S417102023	HMI LED (Optional)	1	1	1	1	1	1	1	1
KMR-CFW09	S417102036	Kit KMR (Optional)	1	1	1	1	1	1	1	1
CFI1.01	S41510226	Interface board with HMI (Optional)	1	1	1	1	1	1	1	1
EBA1.01	S41510110	Function Expansion Board (Optional)	1	1	1	1	1	1	1	1
EBA1.02	S41511761	Function Expansion Board (Optional)	1	1	1	1	1	1	1	1
EBA1.03	S41511770	Function Expansion Board (Optional)	1	1	1	1	1	1	1	1
EBB.01	S41510200	Function Expansion Board (Optional)	1	1	1	1	1	1	1	1
EBB.02	S41511788	Function Expansion Board (Optional)	1	1	1	1	1	1	1	1
EBB.03	S41511796	Function Expansion Board (Optional)	1	1	1	1	1	1	1	1
EBB.04	S41512671	Function Expansion Board (Optional)	1	1	1	1	1	1	1	1
EBB.05	S41512741	Function Expansion Board (Optional)	1	1	1	1	1	1	1	1
EBC1.01	S41513174	Function Expansion Board (Optional)	1	1	1	1	1	1	1	1
EBC1.02	S41513175	Function Expansion Board (Optional)	1	1	1	1	1	1	1	1
EBC1.03	S41513176	Function Expansion Board (Optional)	1	1	1	1	1	1	1	1
SCI1.00	S41510846	RS-232 Module for PC (Optional)	1	1	1	1	1	1	1	1
Modbus RTU	S03051277	Anybus-DT Modbus RTU Board (Optional)	1	1	1	1	1	1	1	1
Profibus DP	S03051269	Anybus-S Profibus DP Board (Optional)	1	1	1	1	1	1	1	1
DeviceNet	S03051250	Anybus-S DeviceNet Board (Optional)	1	1	1	1	1	1	1	1

## CFW-09 OPTIONS AND ACCESSORIES

This Chapter describes the optional devices that are available for the CFW-09 and the accessories that may be necessary in specific applications. Options include the Expanded I/O Boards (EBA/EBB), LED-only Keypad, Remote Keypad and Cables, Blank Cover, RS-232 PC Communication kit, The accessories comprise: Encoder, Line Reactor, DC Bus Choke, Load Reactor and RFI filter, boards for Fieldbus communication, kit for extractable assembling, NEMA 4X/IP56 line, HD and RB and PLC board line.

### 8.1 I/O EXPANSION BOARDS

The I/O expansion boards expand the function of the CC9 control board. There are four different I/O expansion boards available and their selection depends on the application and extended functions that are required. The four boards **cannot** be used simultaneously. The difference between EBA and EBB option boards is in the analog inputs/outputs. The EBC1 board is used for the encoder connection. The EBE board is for RS-485 and motor PTC. A detailed description of each board is provided below.

#### 8.1.1 EBA (I/O Expansion Board A)

The EBA board can be supplied in different configurations, combining some specific features. The available configurations are show on table 8.1.

Included Features	EBA Board models - Code		
	EBA.01 A1	EBA.02 A2	EBA.03 A3
Power supply for incremental encoder: isolated internal 12V source, differential input;	Available	Not available	Not available
Buffered encoder output signals: isolated input signal repeater, differential output, available to external 5V to 15V power supply;	Available	Not available	Not available
Analog differential input (AI4): 14 bits (0.006% of the full scale range), bipolar: -10V to +10V, (0 to 20) mA/(4 to 20)mA programmable;	Available	Not available	Available
2 Analog outputs (AO3/AO4): 14 bits (0.006% of the range [±10V]), bipolar: -10V to + 10 V, programmable;	Available	Not available	Available
Isolated RS-485 serial port.	Available	Available	Not available
Digital Input (DI7): isolated, programmable, 24V;	Available	Available	Available
Digital Input (DI8) for special motor thermistor (PTC) function: actuation 3.9kΩ,release 1.6kΩ	Available	Available	Available
2 isolated Open Collector transistor outputs (DO1/DO2): 24V, 50mA, programmable;	Available	Available	Available

Table 8.1 - EBA board versions and included features



#### NOTE!

The use of the RS-485 serial interface does not allow the use of the standard RS-232 input - they can not be used simultaneously.

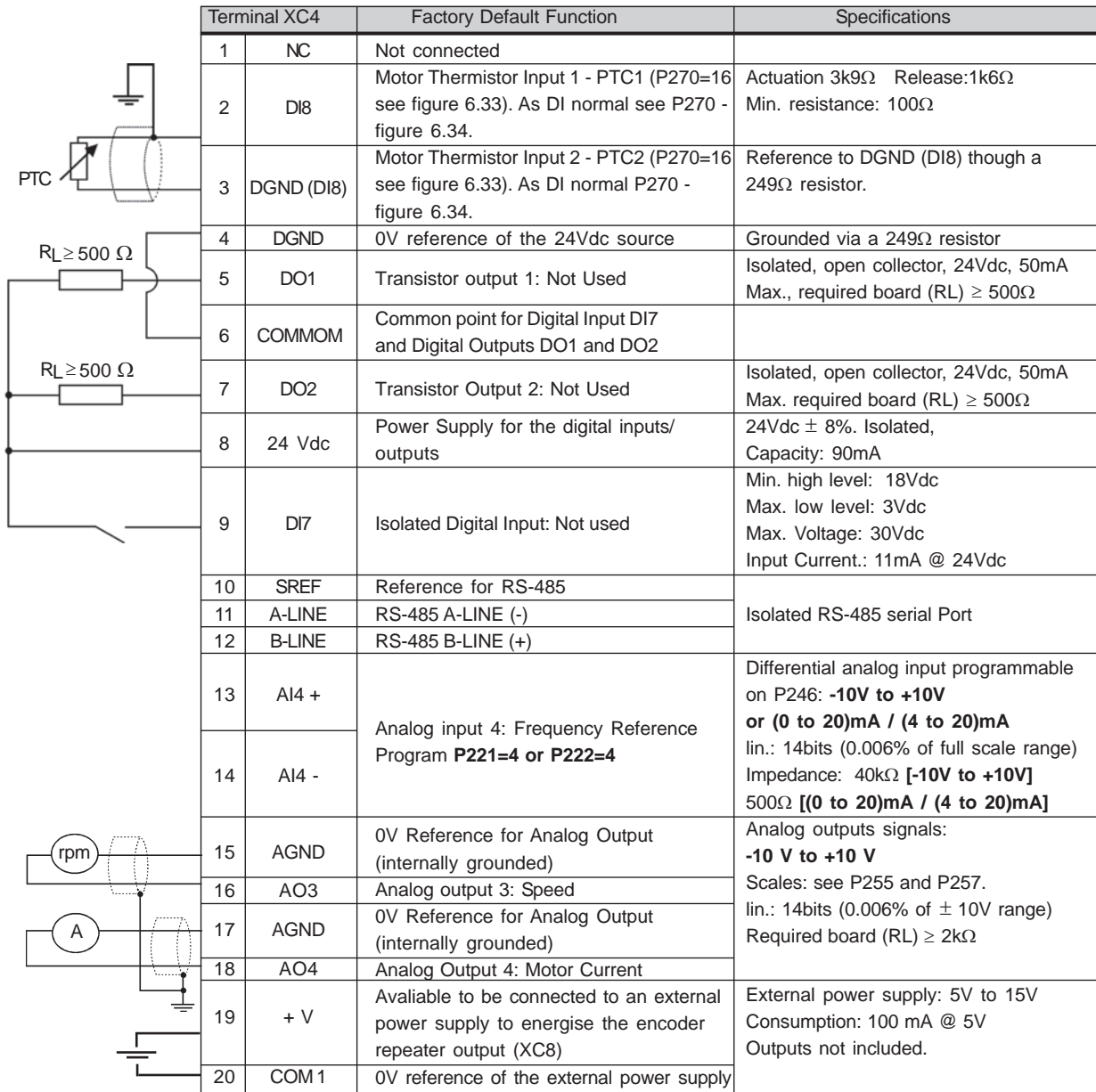

Figure 8.1 – XC4 Terminal Block description (EBA Board complete)

**ENCODER CONNECTION: Refer to Section 8.2.**

**INSTALLATION**

The EBA board is installed on the CC9 control board, secured with spacers and connected via terminal blocks XC11 (24V\*) and XC3.



**NOTE!**

For the CFW-09 Size 1 Models (6A, 7A, 10A and 13 A/220-230V and 3.6A, 4A, 5.5A and 9 A/380-480V) the plastic cover must be removed to install the EBA board.

**Mounting Instructions:**

1. Set the board configuration via S2 and S3 dip switches (Refer to Table 8.2);
2. Carefully insert terminal block XC3 (EBA) into the female connector XC3 of the CC9 control board.

Check that all pins fit in the XC3 connector;

3. Press on the EBA board (near XC3) and on the left top edge until complete insertion of the connector and plastic spacer;
4. Secure the board to the metallic spacers with the screws provided;
5. Plug XC11 connector of the EBA board to the XC11 connector of the (CC9) control board.

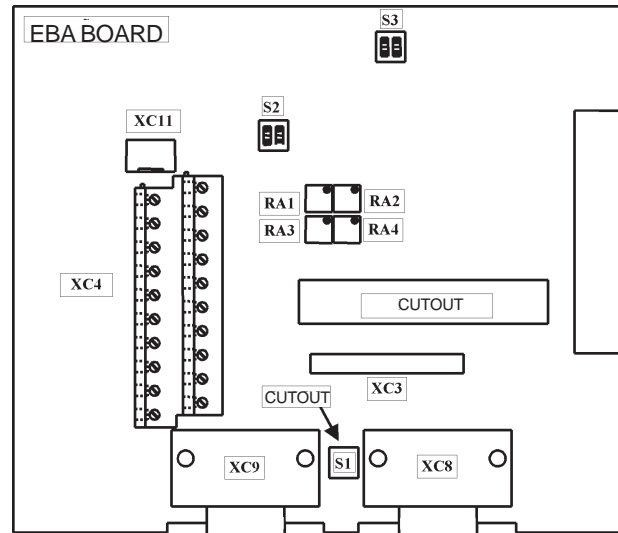

Figure 8.2 - EBA Board layout

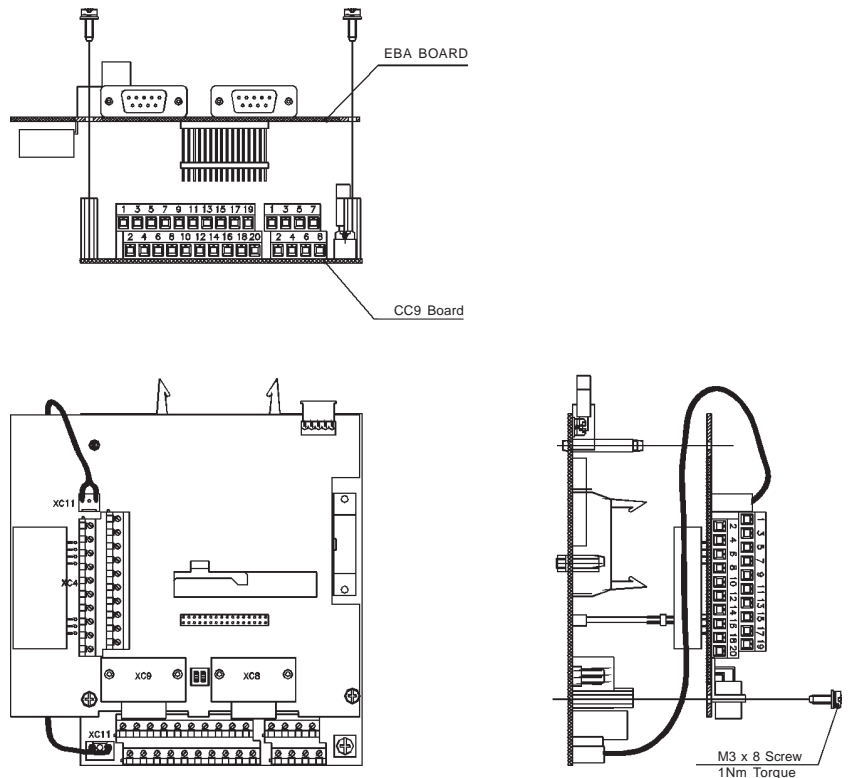

Figure 8.3 - EBA Board installation procedure

Switch	Function	OFF (Standard)	ON
S2.1	AI4 – Speed reference	(0 to 10) V	(0 to 20) mA or (4 to 20)mA
S3.1	RS-485 B-LINE (+)	Without termination	With termination (120Ω)
S3.2	RS-485 A-LINE (-)		

Obs.: Both S3.1 and S3.2 switches must be set for the same option (ON or OFF).

Note: For Size 1 models the CF11 board (interface between the CC9 control board and the HMI) must be removed to clear access to these switches.

**Table 8.2 a) - EBA board selector switches configurations**

Trimpot	Function	Factory default function
RA1	AO3 – Offset	Motor Speed
RA2	AO3 – Gain	
RA3	AO4 – Offset	Motor Current
RA4	AO4 – Gain	

**Table 8.2 b) - Trimpots configurations EBA board**



**NOTE!**

The external signal and control wiring must be connected to XC4 (EBA ), following the same recommendations as for the wiring of the control board CC9 (Refer to Section 3.2.6).

**8.1.2 EBB (Expansion I/O Board B)**

The EBB board can be supplied in different configurations, combining the features included. The available configurations are show table 8.3.

Included Features	EBA Board models - code				
	EBB.01 B1	EBB.02 B2	EBB.03 B3	EBB.04 B4*	EBB.05 B5
Power supply for incremental encoder: isolated internal 12V source, differential input;	Available	Available	Not available	Available	Not available
Buffered encoder output signals: isolated input signal repeater, differential output, must use to external 5V to 15V power supply;	Available	Not available	Not available	Available	Not available
Analog input (AI3): 10 bits, isolated, unipolar, (0 to 10)V, (0 to 20)mA/(4 to 20)mA, programmable;	Available	Not available	Available	Available	Not available
2 Analog outputs (AO1'/AO2'): 11 bits (0.05% of full scale), unipolar, isolated (0 to 20) mA/(4 to 20) mA, programmable;	Available	Not available	Available	Available	Available
Isolated RS-485 serial port.	Available	Not available	Not available	Available	Not available
Digital Input (DI7): isolated, programmable, 24V;	Available	Available	Available	Available	Not available
Digital Input (DI8) for special motor thermistor function (PTC): actuation 3.9kΩ, release 1.6kΩ	Available	Available	Available	Available	Not available
2 isolated Open Collector transistor outputs (DO1/DO2): 24V, 50mA, programmable;	Available	Available	Available	Available	Not available

\* Board with 5 V souce for the encoder.

**Table 8.3 – EBB board versions and included features**



**NOTE!**

The use of the RS-485 serial interface does not allow the use of the standard RS-232 input - they can not be used simultaneously. The functions analogic outputs AO1' and AO2' are identical to the AO1/AO2 outputs of the control board CC9.

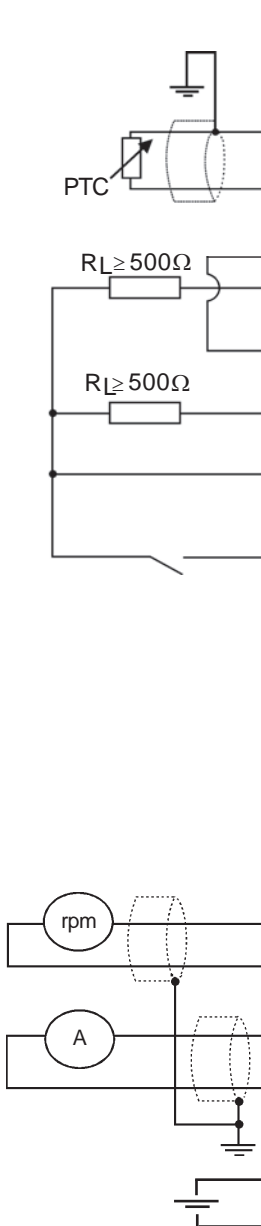

Terminal	XC5	Factory Default Function	Specifications
1	NC	Not Connected	
2	DI8	Motor Thermistor Input 1 - PTC1 (P270=16 see figure 6.33). As DI normal see P270 figure 6.34.	Actuation: 3.9kΩ Release:1.6kΩ Min: resistance: 100Ω
3	DGND (DI8)	Motor Thermistor Input 2 - PTC2 (P270=16 see figure 6.33). As DI normal see P270 figure 6.34.	Referenced to DGND* trough a 249Ω resistor
4	DGND	0V reference of the 24 Vdc source	Grounded via a 249Ω resistor
5	DO1	Transistor Output 1: Not used	Isolated, open collector, 24Vdc, 50mA Max. required board (RL) ≥ 500Ω
6	COMMOM	Commom point for Digital Input DI7 and Digital Outputs DO1 and DO2	
7	DO2	Transistor Output 2: Not Used	Isolated, open collector, 24Vdc, 50mA Max. required board (RL) ≥ 500Ω
8	24 Vdc	Power Supply for the digital inputs/ outputs	24Vdc ± 8%. Isolated, Capacity: 90mA
9	DI7	Isolated digital input: Not Used	Min. high level: 18Vdc Max. low level: 3Vdc Max. Voltage: 30Vdc Input Current.: 11mA @ 24Vdc
10	SREF	Reference for RS-485	Isolated RS-485 serial port
11	A-LINE	RS-485 A-LINE (-)	
12	B-LINE	RS-485 B-LINE (+)	
13	AI3 +	Analog Input 3: Frequecy Reference Program <b>P221=3 or P222=3</b>	Isolated analog input programmable on P243: <b>(0 to 10)V or (0 to 20)mA/(4 to 20)mA</b> lin.: 10 bits (0.1% of full scale range) Impedance: 400kΩ <b>(0 to 10)V</b> 500Ω <b>[(0 to 20)mA/(4 to 20)mA]</b>
14	AI3 -		
15	AGND <sup>1</sup>	0V Reference for Analog Speed	Isolated analog Outputs signals: <b>(0 to 20)mA / (4 to 20)mA</b> Scales: see P251 and P253 lin.: 11bits (0.5% of full scale range) Required board (RL) ≤ 600Ω
16	AO1 <sup>1</sup>	Analog Output 1: Speed	
17	AGND <sup>1</sup>	0V Reference for analog Output	
18	AO2 <sup>1</sup>	Analog Output 2 : Motor Current	
19	+ V	Availible to be connected to an external power supply to engerise the encoder repeater output (XC8)	External power supply: 5V to 15V, consumption: 100 mA @ 5V Outputs not included.
20	COM 1	0V reference of the external power supply	

Figure 8.4 - XC5 Terminal Block description (complete EBB board)



**ATTENTION!**

The isolation of the analog input AI3 and the analog outputs AO1<sup>1</sup> and AO2<sup>1</sup> is designed only to interrupt the ground loops. Do not connect these inputs to high potentials.

**ENCODER CONNECTION: Refer to Section 8.2. INSTALLATION**

The EBB board is installed on the CC9 control board, secured with spacers and connected via Terminal blocks XC11 (24V) and XC3.



**NOTE!**

For the CFW-09 Size 1 Models (6A, 7A, 10A and 13A / 220-230V and 3.6A, 4A, 5.5A and 9A / 380-480V) the plastic cover must be removed to install the EBB board.

Mounting Instructions:

1. Set the board configuration via S4, S5, S6 and S7 dip switches (Refer to Table 8.4 a) );
2. Carefully insert terminal block XC3 (EBB) into the female connector XC3 of the CC9 control board. Check that all pins fit in the XC3 connector;
3. Press on the EBB board (near XC3) and on the left top edge until complete insertion of the connector and plastic spacer;
4. Secure the board to the metallic spacers with the screws provided;
5. Plug XC11 connector of the EBB board to the XC11 connector of the (CC9) control board.

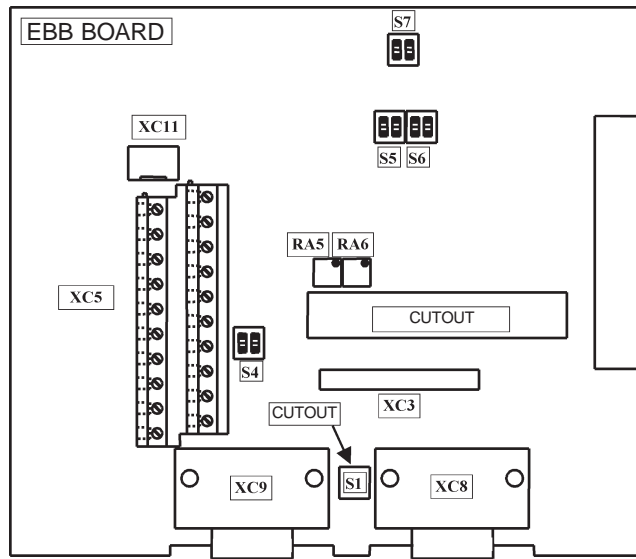

Figure 8.5 - EBB Board Layout

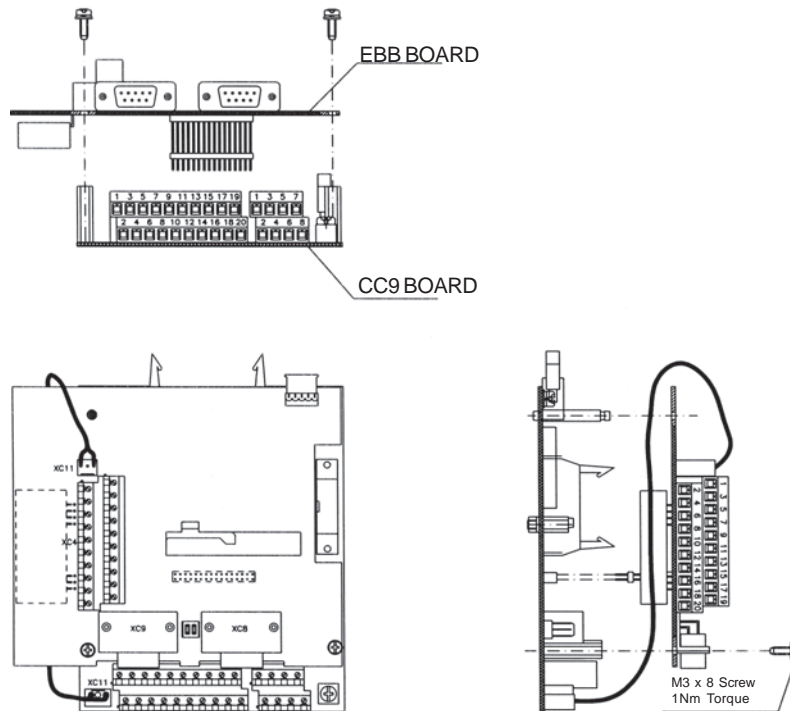

Figure 8.6 - EBB Board Installation Procedure

Switch	Function	OFF	ON
S4.1	AI3 – Speed reference	(0 to 10) V*	(0 to 20) mA or (4 to 20) mA
S5.1 and S5.2	AO1 - Speed	(0 to 20) mA**	(4 to 20) mA*
S6.1 and S6.2	AO2 – Motor Current		
S7.1 and S7.2	RS-485 B-Line (+)	Without termination*	With termination (120Ω)
	RS-485 A-Line (-)		

\*Factory default

Obs.: Each group of switches must be set for the same option (ON or OFF for both).

Ex.: S6.1 and 6.2 = ON.

\*\*Factory default

When the outputs are set to (0 to 20) mA, it may be necessary to readjust the full scale.

Note: For Size 1 models the CF11 board (interface between the CC9 control board and the HMI) must be removed to clear access to these switches.

Table 8.4 a) - EBB board selector switches configurations

Trimpot	Function	Factory default function
RA5	AO1 – Full scale adjustment	Motor Speed
RA6	AO2 – Full scale adjustment	Motor Current

Table 8.4 b) - Trimpots configurations EBB board



**NOTE!**

The external signal and control wiring must be connected to XC (EBB), following the same recommendations as for the wiring of the control board CC9 (Refer to Section 3.2.6).

8.1.3 EBE

Please download from [www.weg.net](http://www.weg.net) the EBE Board Quick Guide.

8.2 INCREMENTAL ENCODER

For applications that require high-speed accuracy, the actual motor speed must be fed back via motor-mounted incremental encoder. The encoder is connected electrically to the inverter through the XC9 (DB9) connector of the Function Expansion Board - EBA or EBB and XC9 or XC10 to EBC.

8.2.1 EBA/EBB Boards

When the board EBA or EBB is used, the selected encoder should have the following characteristics:

- Power supply voltage: 12 Vdc, less than 200 mA current draw;
- 2 quadrature channels (90°) + zero pulse with complementary outputs (differential): signals A,  $\bar{A}$ , B,  $\bar{B}$ , Z and  $\bar{Z}$ ;
- “Linedriver” or “Push-Pull” output circuit type (level 12V);
- Electronic circuit isolated from encoder frame;
- Recommended number of pulses per revolution: 1024 ppr;

For mounting the encoder on the motor, follow the recommendations bellow:

- Couple the encoder directly to the motor shaft (use a flexible coupling without torsional flexibility);
- Both the shaft and the metallic frame of the encoder must be electrically isolated from the motor (min. Spacing: 3 mm (0.119 in));
- Use high quality flexible couplings to prevent mechanical oscillation or backlash;

The electrical connections must be made with shielded cable, maintaining a minimum distance of about 25 cm (10 in) from other wires (power, control cables, etc.). If possible, install the encoder cable in a metallic conduit.

At start-up, program Parameter **P202** – Type of Control = 4 (Vector with Encoder) to operate the motor with incremental encoder speed feedback. For more details about Vector Control operation refer to Chapter 5.

The Expanded I/O Boards EBA and EBB are provided with externally powered, isolated encoder output signals.

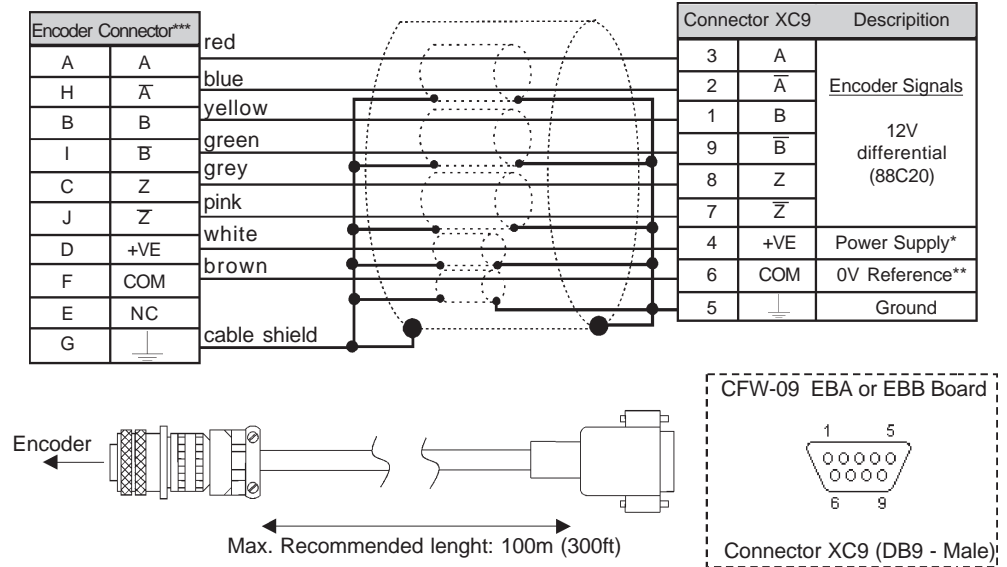

\* Power supply voltage 12Vdc / 220mA for encoder  
 \*\* Referenced to ground via 1μF in parallel with 1kΩ  
 \*\*\* Valid pin position with encoder HS35B models from Dynapar. For other encoder modules, check the correct connection to meet the required sequence.

Figure 8.7 – Encoder Cable



**NOTE!**

The max. permitted encoder frequency is 100 kHz.

Sequence of the encoder signals:

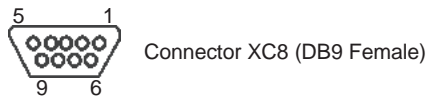
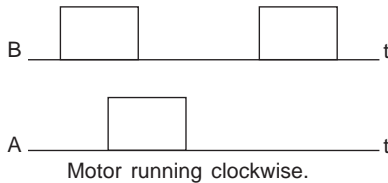

\*For an external power supply: 5V to 15V  
 Consumption: 100 mA @ 5V, outputs not included.

Note.: Optionally, the external power supply can also be connected via:  
 XC4:19 and XC4:20 (EBA) or  
 XC5:19 and XC5:20 (EBB)



**NOTE!**

There is no internal power supply for XC8 at EBA or EBB board.

CFW-09 EBA or EBB Board

Connector XC8		Description
3	A	Encoder Signals Line Driver differential (88C30) Average high level current: 50 mA
2	Ā	
1	B	
9	B̄	
8	Z	
7	Z̄	
4	+V*	Power Supply*
6	COM 1*	0 V Reference
5	⊥	Ground

Figure 8.8 – Encoder signals repeater output

8.2.2 EBC1 Board

When the board EBC1 is used, the selected encoder should have the following characteristics:

- ☑ Power Supply Voltage: 5 V to 15 V;
- ☑ 2 quadrature channels (90°) with complementary outputs (differential):
- ☑ Signals A, A̅, B and B̅;  
"Linedriver" or "Push-Pull" output circuit type (with identical level as the power supply voltage);
- ☑ Electronic circuit isolated from the encoder frame;
- ☑ Recommended number of pulse per revolution: 1024 ppr;

**INSTALLATION OF THE EBC BOARD**

The EBC board is installed directly on the control board CC9, fixed by means of spacers and connected through the XC3 connector.



**NOTE!**

For installation in the models of size 1, remove the lateral plastic cover of the product.

**Mounting instructions:**

1. Insert carefully the pins of the connector XC3 (EBC1) into the female connector XC3 of the control board CC9. Check if all pins of the connector XC3 fit exactly;
2. Press on the board center (near to XC3) until the connector is inserted completely.
3. Fix the board to the 2 metallic spacers by means of the 2 bolts;

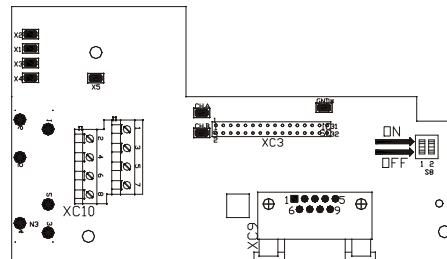

Figure 8.9 - EBC Board Layout

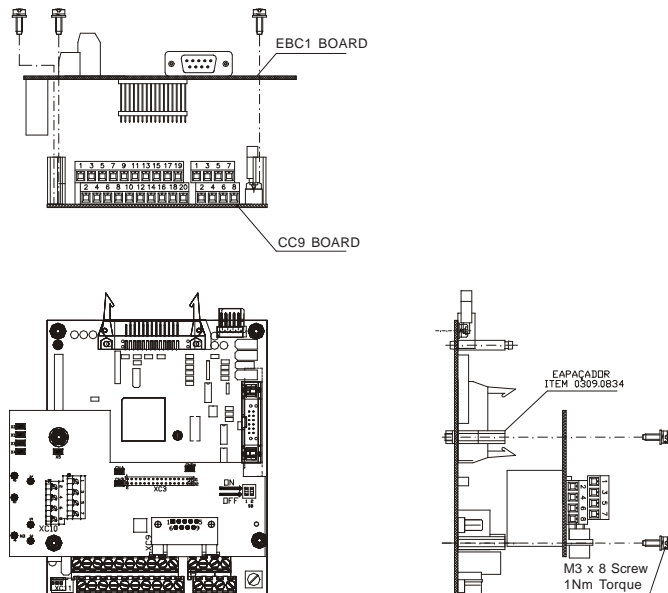

Figure 8.10 - EBC1 Board Installation Procedures

**CONFIGURATIONS**

Expansion Board	Power Supply	Encoder Voltage	Customer Action
EBC1.01	External 5V	5V	Commutate switch S8 to ON, see figure 8.9
	External 8 to 15V	8 to 15V	None
EBC1.02	Internal 5V	5V	None
EBC1.03	Internal 12V	12V	None

Table 8.5 - EBC1 board configuration



**NOTE!**

The terminals XC10:22 and XC10:23 (see figure 8.9), should be used only for encoder supply, when encoder power supply is not coming from DB9 connection.

**MOUNTING OF THE ENCODER**

For mounting the encoder on the motor, follow the recommendations below:

- ☑ Couple the encoder directly to the motor shaft (use a flexible coupling without torsional flexibility);
- ☑ Both the shaft and the metallic frame of the encoder must be electrically isolated from the motor. (min. spacing: 3mm (0.119 in));
- ☑ Use high quality flexible couplings to prevent mechanical oscillation or backlash;

The electrical connection must be made with shielded cable, maintaining a minimum distance of about 254 mm (10 in) from other wiring (power, control cables, etc.). If possible, install the encoder cable in a metallic conduit.

At start-up, program Parameter **P202** - type of control - = 4 (vector with encoder) to operate the motor with speed feedback through incremental encoder.

For more details about Vector Control operation, refer to Chapter 5.

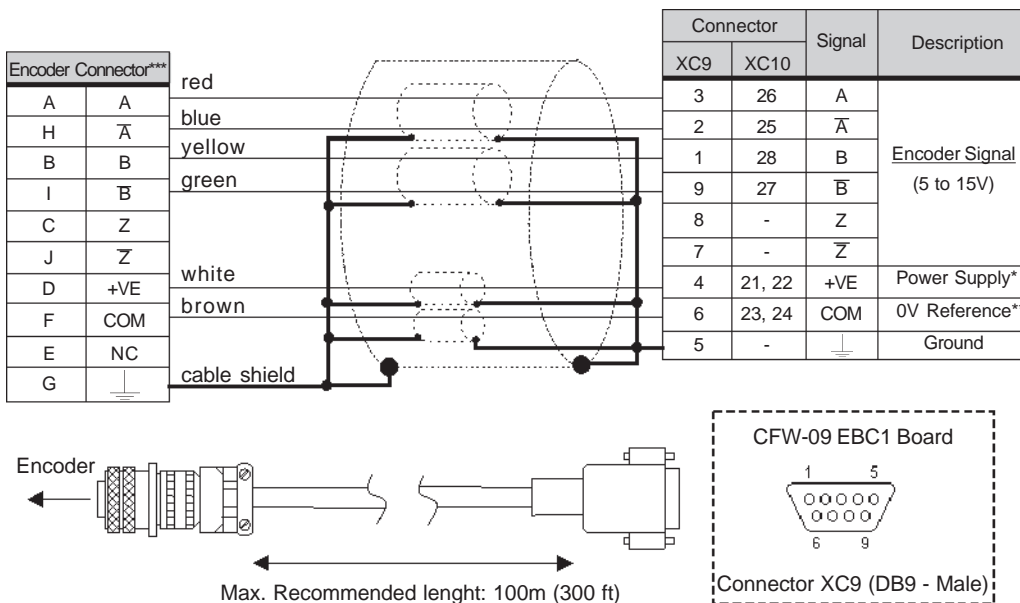

\* External Power Supply Voltage for encoder: 5 to 15 Vdc, consumption = 40 mA plus consumption of the encoder  
 \*\* 0V reference of the Power Supply Voltage  
 \*\*\* Valid pin position with encoder HS35B models from Dynapar. For other encoder models, check the correct connection to meet the required sequence.

Figure 8.11 – EBC1 Encoder Input



**NOTE!**

The Max. permitted encoder frequency is 100kHz.

Sequence of the encoder signals:

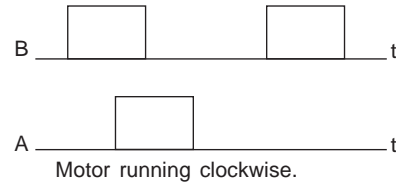

**8.3 KEYPAD WITH LED'S ONLY**

The CFW-09 standard Keypad (HMI) is provided with LED's and LCD display. It can also be supplied with an LED Display only. In this case the keypad model number is: HMI-CFW-09-LED. It operates in the same way as the standard keypad, but it does not show the text messages of the LCD and does not provide the copy function. The dimensions and the electrical connections are the same as for the standard keypad. Refer to Section 8.4.

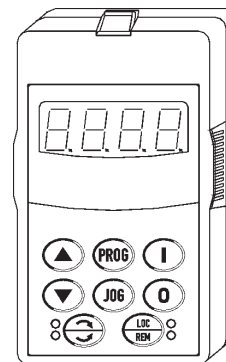

Figure 8.12 - Keypad with LED display only

**8.4 REMOTE KEYPAD AND CABLES**

The CFW-09 keypad (both the standard or the LED display only) can be installed directly on the inverter cover or remotely. If the keypad is installed remotely, the HMI-09 Frame can be used. The use of this frame improves the visual aspect of the remote keypad, as well as provides a local power supply to eliminate voltage drop problems with long cables. It is necessary to use the frame when the keypad cable is longer than 5 m (15 ft).

The table below shows the standard cable lengths and their part numbers:

Cable Length	WEG Part N°
1 m (3 ft)	0307.6890
2 m (6 ft)	0307.6881
3 m (10 ft)	0307.6873
5 m (15 ft)	0307.6865
7.5m *(22 ft)	0307.6857
10 m *(30 ft)	0307.6849

\* These cables require the use of the remote HMI-09 frame

Table 8.6 - CFW-09 keypad cables

The keypad cable must be installed separately from the power cables, following the same recommendations as for the CC9 control board (refer to section 3.2.6).

For assembling see details in figure 8.13 and 8.14.

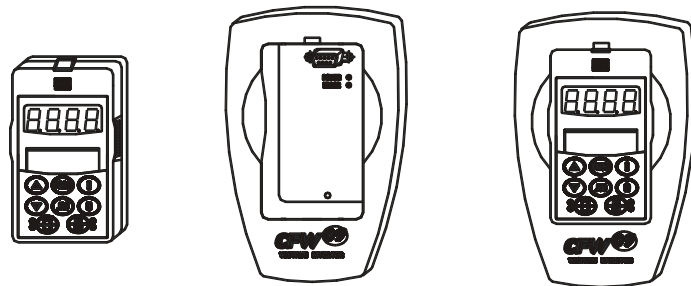

Figure 8.13 - Standard HMI, remote HMI frame kit and HMI CFW09 – LCD N4 for panel installation

To meet NEMA 250 and IEC 60529 the HMI can be supplied with two specific degrees of protection:

- a) Dimensions of the HMI – CFW09 – LED/LCD with NEMA 5-IP51 degree of protection.

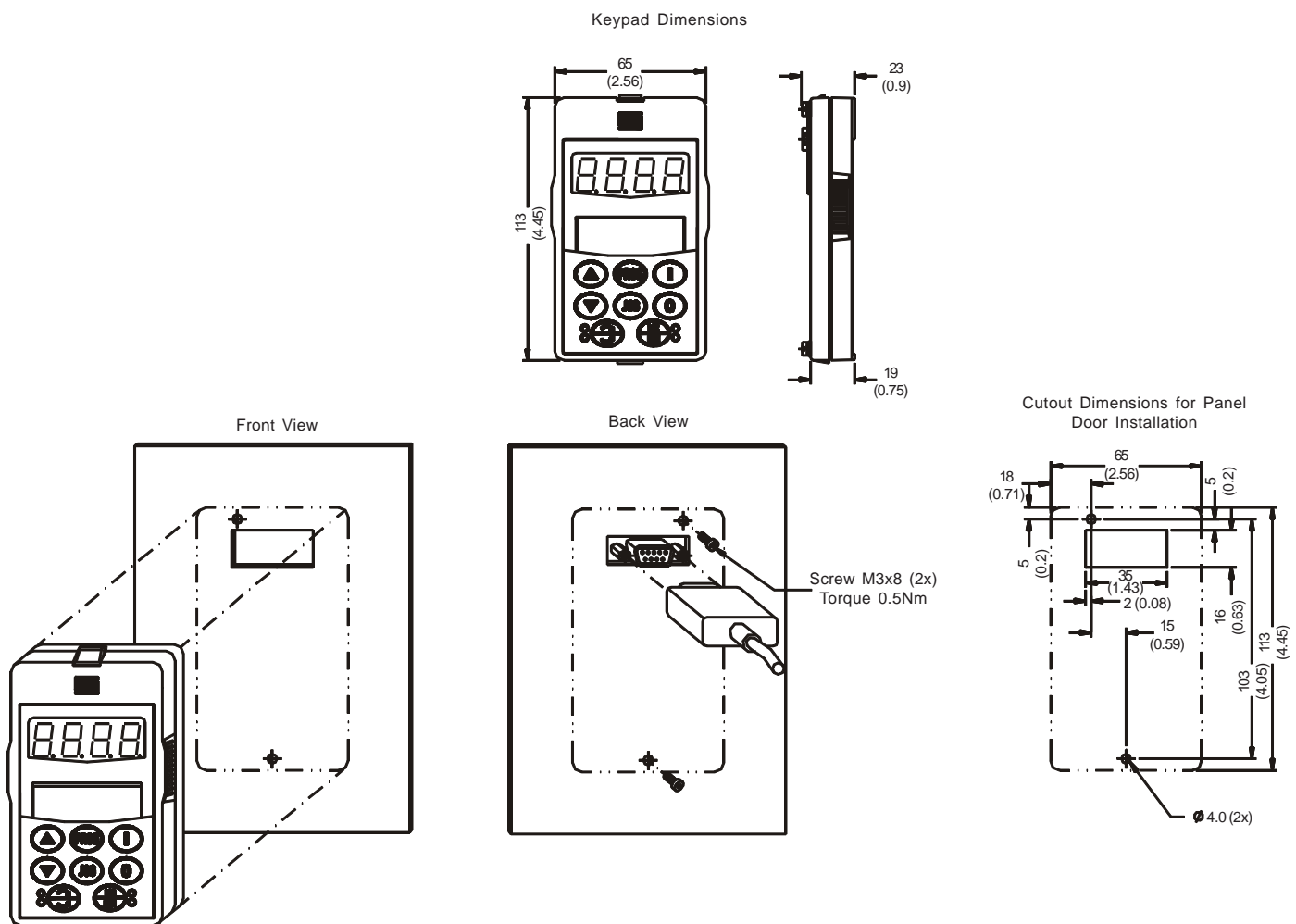
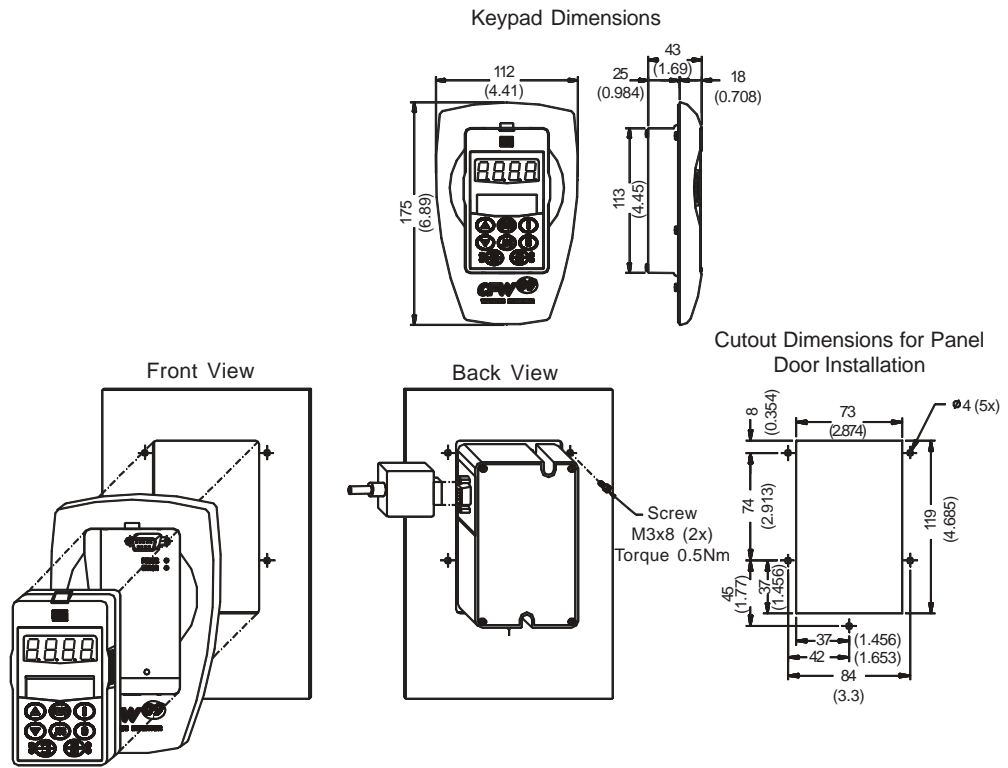

Figure 8.14 a) - Keypad dimensions in mm (inch) and mounting procedures

b) Dimensions of the HMI – CFW09 – LED/LCD + remote HMI frame kit with NEMA5-IP51 degree of protection.



c) Dimensions of the HMI – CFW09 – LED/LCD-N4 with NEMA 4-IP56 degree of protection.

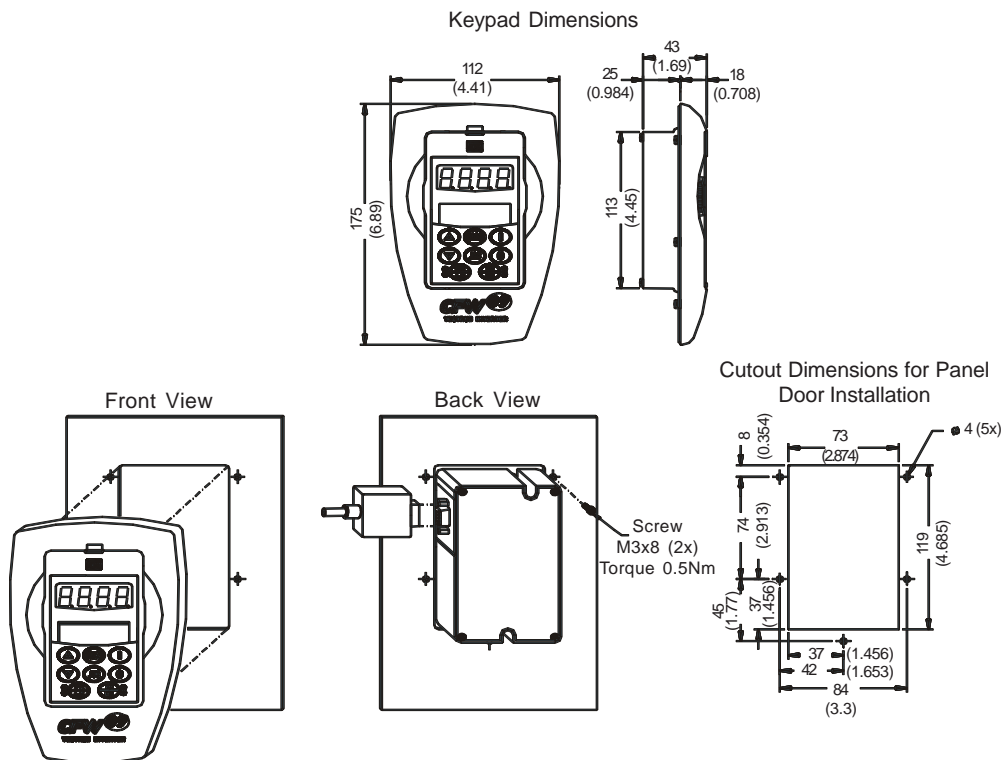
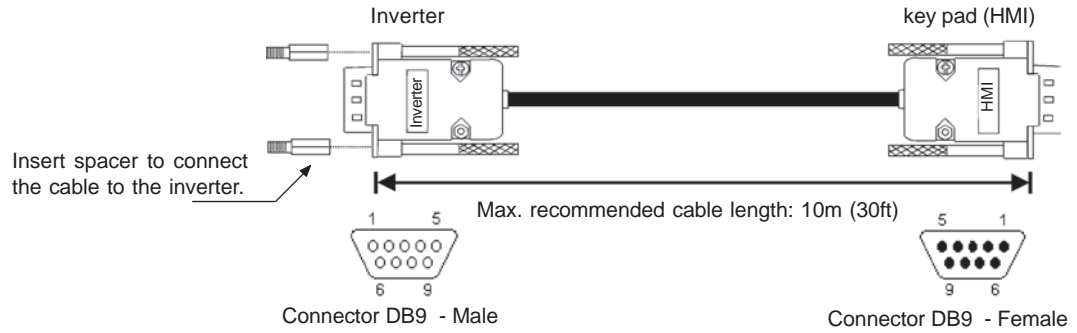

Figure 8.14 b) c) - Keypad dimensions in mm (inch) and mounting procedures

**Remote HMI connection for distances higher than 10m (30 ft):**



**Figure 8.15** - Cable for remote keypad connection  $\leq 10m$

CABLE CONNECTION 5m $\leq$ (15 ft)		
Connector Pin/ Inverter Side	Connector Pin/ HMI Side	Signal
1	1	+5V
2	2	Rx
3	3	Tx
4	4	GND
8	8	+15V
9	9	SHIELD

Note: The frame can be used or not.

**Table 8.7** - Connections for remote keypad cable up to 5 m (15 ft).

CABLE CONNECTION >5m (>15 ft)		
Connector Pin/ Inverter Side	Connector Pin/ HMI Side	Signal
2	2	Rx
3	3	Tx
4	4	GND
8	8	+15V
9	9	SHIELD

Note: The frame must be used.

**Table 8.8** - Connections for remote keypad cable from 7.5 m (22 ft) to 10 m (30 ft).

**Remote HMI connection for distances farther than 10m (30 ft):**

The HMI can be connected to the inverter using a cable length up to 200 m (600 ft). It is necessary to use an external power supply of 15Vdc, according to figure 8.16.

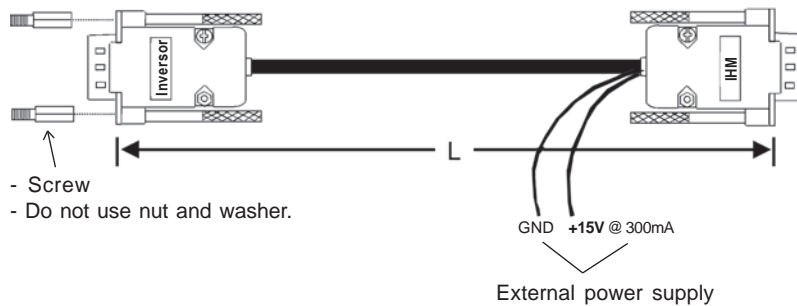

**Figure 8.16** - Cable for remote keypad connection  $> 10m$

CABLE CONNECTION		
Connector Pin/ Inverter Side	Connector Pin/ HMI Side	Signal
2	2	Rx
3	3	Tx
-	4	GND
-	8 (Ext. power supply)	+15V
9	9 (Ext. power supply)	Shield

**Table 8.9** - Pin connection (DB9) for cable > 10m (32,80 ft) and ≤ 200 m (656 ft).

### 8.5 BLANK COVERS

As shown in Figure 8.17, two types of blank covers are available to be used, in the inverter or in the frame, when the keypad is not in place.

a) CFW-09 Blank Cover (to be mounted in the frame)

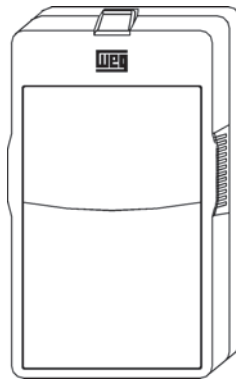

b) CFW-09 Blank Cover with Power and Error LED's (to be mounted in the inverter)

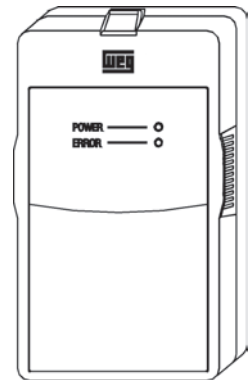

**Figure 8.17 a) b)** – CFW-09 Blank Covers

### 8.6 RS-232 PC COMMUNICATION KIT

The CFW-09 can be controlled, programmed and monitored via an RS-232 Serial Interface. The communication protocol is based on question/response telegrams according to ISO 1745 and ISO 646 standards, with ASCII characters exchanged between the inverter and a master (network controller, which can be a PLC, PC, etc.). The maximum transfer rate is 9600 bps. The RS-232 serial interface is not galvanically isolated from the 0V reference of the inverter electronics, therefore the maximum recommended serial cable length is 10m (30ft).

To implement the serial communication, an RS-232 SERIAL INTERFACE module has to be added to the CFW-09. This module is installed in place of the Keypad, making the RS-232 connection (RJ11 connector) available. If the use of the HMI is also required, the RS-232 module also provides its connection.

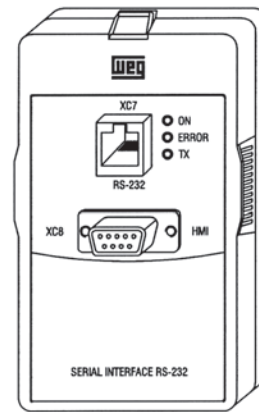

Figure 8.18 - RS-232 module

The RS-232 PC Communication Kit which allows the connection of the CFW-09 to a PC via the RS-232 interface is composed of:

- RS-232 Serial Interface Module;
- 3 m (10 ft) Cable for RJ-11 to DB9 connection;
- SuperDrive Software for Windows for CFW-09 programming, operation and monitoring. See hardware and system needs for SuperDrive.

To install the RS-232 PC communication kit, proceed as follows:

- Remove the keypad (HMI) from the inverter;
- Install RS-232 Serial Interface Module in place of the keypad;
- Install the SuperDrive software in the PC. Consult the on-line help or installation guide;
- Use the cable to connect the inverter to the PC;
- Follow the SuperDrive software instructions. Consult the on-line help or installation guide.

## 8.7 LINE REACTOR / DC BUS CHOKE

Due to the input circuit characteristic, common to all passive front end inverters available in the market, which consists of a six diode rectifier and capacitor bank, the input current (drained from the power supply line) of inverters is non sinusoidal and contains harmonics of the fundamental frequency.

These harmonic currents circulate through the power supply line, causing harmonic voltage drops which distort the power supply voltage of the inverter and other loads connected to this line. These harmonic current and voltage distortions may increase the electrical losses in the installation, overheating components (cables, transformers, capacitor banks, motors, etc.), as well as a lowering power factor.

The harmonic input currents depend on the impedance values that are present in the rectifier input/output circuit. The addition of a line reactor and/or DC bus choke reduces the current harmonic content, providing the following advantages:

- Increased input power factor;
- Reduced RMS input current;
- Reduced power supply voltage distortion;
- Increased life of the DC link capacitors.

The Line Reactor and the DC Bus Choke, when properly sized, have practically the same efficiency in reducing the harmonic currents. The DC Bus Choke has the advantage of not introducing a motor voltage drop, while the Line Reactor is more efficient to attenuate power supply voltage transients.

DC Link Inductor equivalent to the line reactor is:

$$L_{DC-EQUIVALENT} = L_{AC} \times \sqrt{3}$$



**NOTE!**

The 44A to 79A/500-600V, 107A to 472A/500-690V and 100A to 428A/660-690V models have a DC link inductor built in the standard version. It is not necessary to have minimum supply impedance or add external line inductors for protecting these models.

8.7.1 Application Criteria

The line reactor or the DC Link Inductor shall be applied when required impedance is insufficient for limiting the input current peaks, thus preventing damages to the CFW-09. The minimum required impedances, expressed as impedance drop in percent are following:

- a) For the model with rated current  $\leq 130A/220-230V$ ,  $\leq 142A/380-480V$  or  $\leq 32A/500-600V$ : drop of 1% for the line voltage;
- b) For the model with rated current  $\geq 180A/380-480V$ : drop of 2% for the line voltage;
- c) For models with rated current  $\geq 44A/500-600V$  or  $\geq 107A/500-690V$  or  $\geq 100A/660-690V$ : there is no requirement for the minimum required line impedance for the CFW-09 protection. These impedances are ensured by the internal existing DC choke. The same is applicable when DC link inductor is incorporated into the product (Special Hardware - Code HC or HV), in the models with currents  $\geq 16A/220-230V$  or  $\geq 13A/380-480V$  and  $\leq 240A/380-480V$ .

As an **alternative criteria**, a line reactor should be added when the inverter supply transformer has a rated power higher than indicated below:

CFW-09 Rated Current/ volts	Transformer Power [kVA]
6A to 28A/220-230V 3.6A to 24A/380-480V 2.9A to 14A/500-600V	125
45A to 130A/220-230V 30A to 142A/380-480V 22A to 32A/500-600V	5 X Inverter Rated Power
180A to 600A/380-480V	2 X Inverter Rated Power

**Table 8.10** - Line reactor usage criteria

- To determine the line reactor needed to obtain the desired voltage drop, use equation below:

$$L = \frac{\text{Voltage Drop [\%]} \times \text{Line Voltage [V]}}{\sqrt{3} \times 2\pi \text{ Line Freq [Hz]} \times \text{Rated Cur.[A]}} \text{ [H]}$$

The electrical installation of an input line reactor is shown on Figure 8.19 a). For CFW-09 sizes above 16 A/220-230V or 13 A/380-480V, the connection of a DC Bus Choke is possible. The DC bus choke connection is also possible in all 2.9A to 32A/500-600V models. Figure 8.19 b) shows this connection.

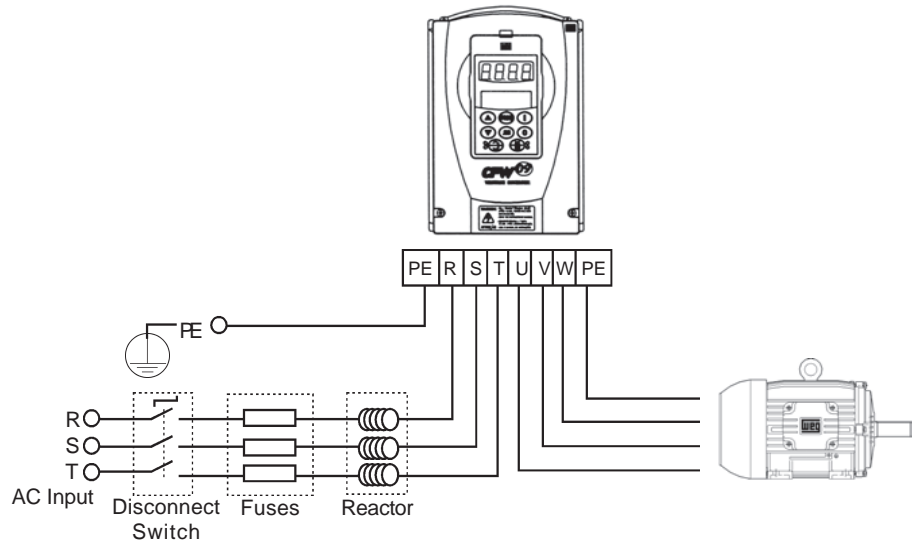

Figure 8.19 a) – Line reactor connection

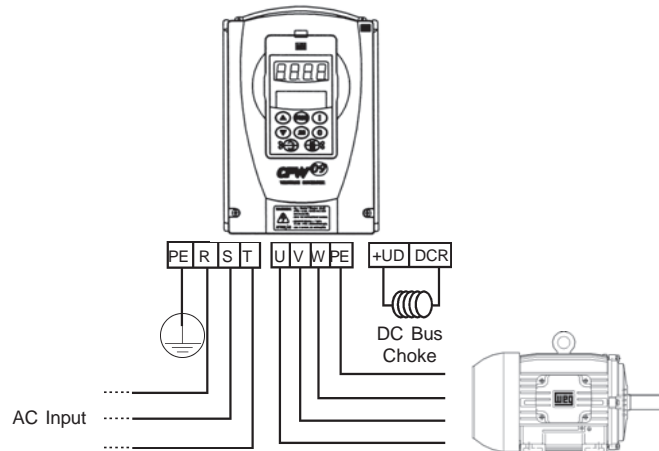

Figure 8.19 b) – DC Bus Choke connection

8.7.2 DC Link Inductor Built in

The following CFW-09 inverter models, can be fitted with an inductor at the DC Link already incorporated into the product:  
 Models  $\geq 16A/220-230V$ , Models  $\geq 13A/380-480V$  and Models  $\leq 240A/380-480V$ .

To request the inverter with an inductor already assembled, please add the code "HC" (for inverter operating at constant torque) or "HV" (for inverter operating with variable torque) in the model CFW-09, in the option field "Special Hardware" (see Item 2.4).



**NOTE!**

Remember that the operation at higher currents than the rated current in variable Torque mode is not possible with all inverter types (see Item 9.1.2 and Item 9.1.3). Thus the HV option is only possible with the types that can be operated in that situation.

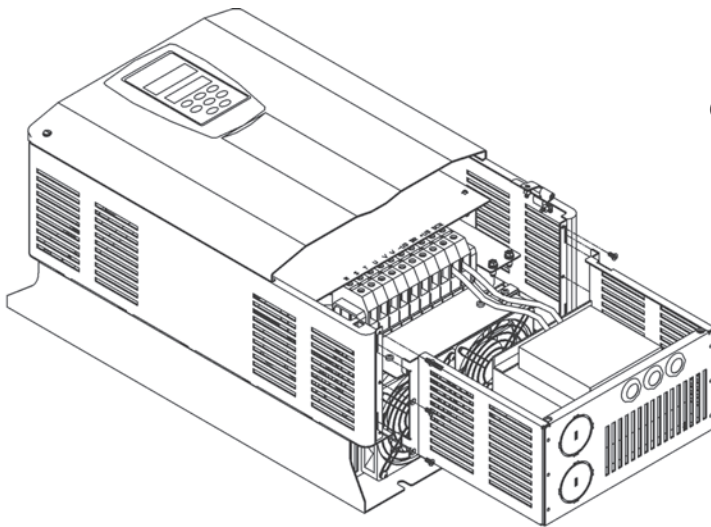

CFW-09 with DC link inductor

Sizes 2 to 8

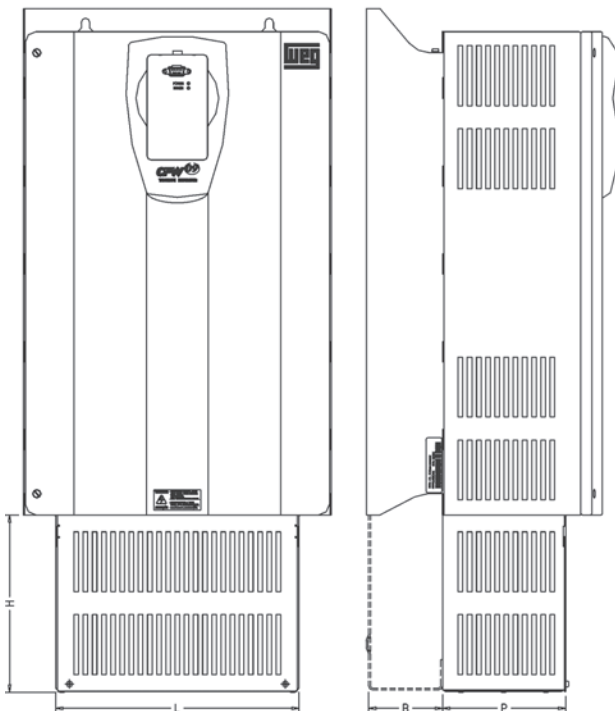

Dimensions mm (inch)

Model	L	H	P	B
Size 2	160 (6.30)	120 (4.72)	105.5 (4.15)	-
Size 3	153 (6.02)	137 (5.39)	134 (5.27)	-
Size 4	180 (7.08)	172 (6.77)	134 (5.27)	-
Size 5	265 (10.43)	193.5 (7.57)	134 (5.27)	-
Size 6-7	265 (10.43)	212.5 (8.36)	159 (6.25)	-
Size 8	325 (12.79)	240 (9.44)	221.5 (8.72)	80.5 (3.16)

Table 8.11 - CFW-09 with DC link inductor dimensions.

## 8.8 LOAD REACTOR

The use of a three-phase load reactor, with an approximate 2% voltage drop decreases the  $dv/dt$  (voltage rising rate) of the PWM pulses commonly generated at the inverter output of any AC frequency converter.

This practice reduces the voltage spikes on the motor windings and leakage currents that may be generated when long distance cables between inverter and motor are used.

There are many factors that influence the peak level ( $V_p$ ) and rise time ( $t_r$ ) of voltage spikes. Cable type, cable length, motor size, switching frequency and other variables all affect  $V_p$  and  $dv/dt$ .

WEG recommends using a load reactor when  $V$  supply  $> 500V$ , though this is not always required. WEG, as specialists in both VSD's and motors are able to provide an integrated solution. The load reactor value is calculated in the same way as the line reactor (See item 8.7.1).

If the cables between inverter and motor are longer than 100 m (300 ft), the cable capacitance to ground may cause nuisance overcurrent (E00) or ground fault (E11) trips. In this case it is also recommended to use a load reactor.

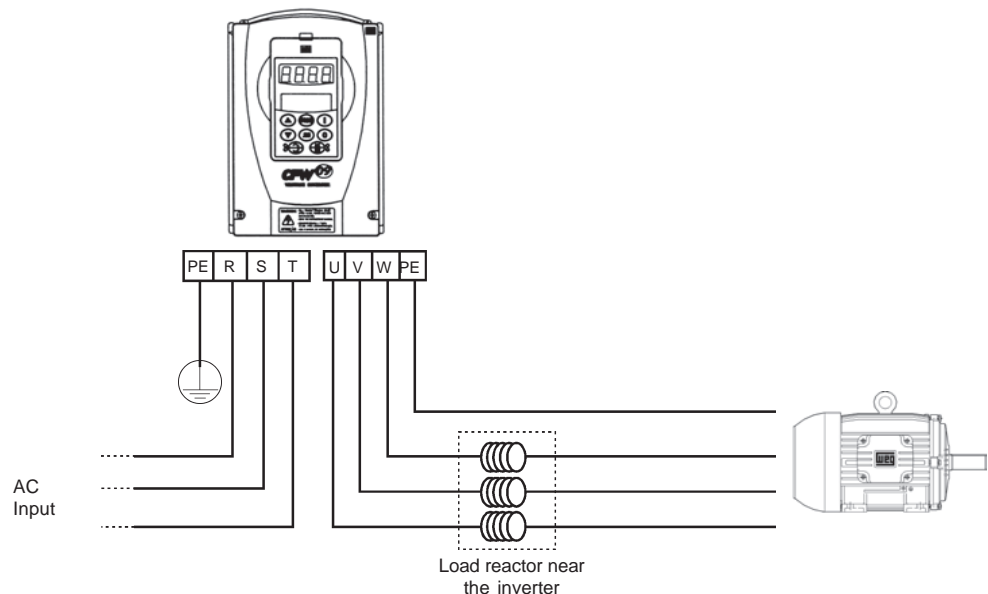

Figure 8.20 – Load reactor connection

## 8.9 RFI FILTER

The installation of frequency inverters requires certain care in order to prevent electromagnetic interference (EMI). This interference may disturb the operation of the inverter itself or other devices, such as, electronic sensors, PLCs, transducers, radio equipment, etc.

To avoid these problems, follow the installation instructions contained in this Manual. Never install electromagnetic noise generating circuits such as input power and motor cables near analog signal or control cables.

Care should also be taken with the radiated interference, by shielding the cables and circuits that tend to emit electromagnetic waves and cause interference.

The electromagnetic interference can also be transmitted through the power supply line. This type of interference is minimized in the most cases by capacitive Radio Frequency Filters (common and differential mode) which are already installed inside the CFW-09. However, when inverters are installed in residential areas, the installation of an external additional filter may be required. In this case contact WEG to select the most suitable filter type.

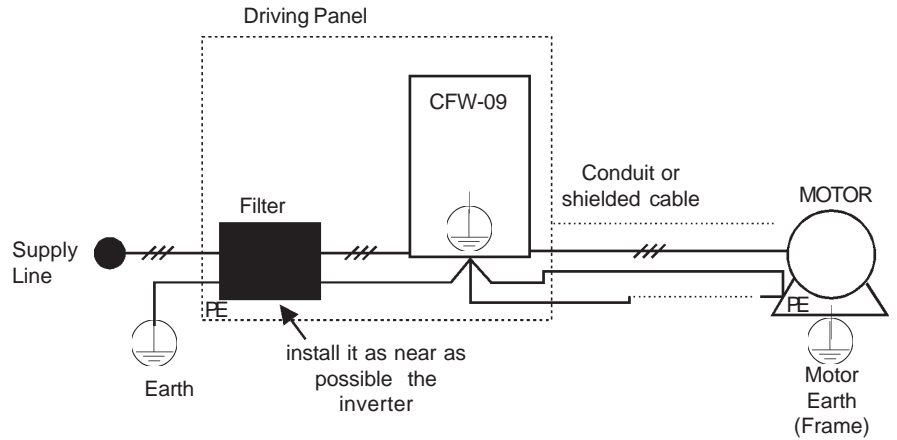

Figure 8.21 – RFI Filter connection

**Instructions for the RFI filter installation:**

- ☑ Install the inverter and the filter on a metallic grounded plate as near to each other as possible and ensure a good electrical contact between the grounded plate and the inverter and filter frames;
- ☑ If the cable between inverter and filter is longer than 30 cm (12 in), use a shielded cable and ground each shield end on the grounded mounting plate.



**NOTE!**

Installations that must meet the European standards, see item 3.3.

8.10 DYNAMIC BRAKING

The amount of braking torque that can be generated when a motor is controlled by an inverter, without dynamic braking or any other braking schemes, varies from 10% to 35% of the motor rated torque.

During the deceleration process, the kinetic energy of the load is regenerated into the inverter’s DC Link. This energy loads up the capacitors increasing the DC Link voltage. When this energy is not fully dissipated, it may generate a DC Link overvoltage trip (E01).

To obtain higher braking torque, the use of Dynamic Braking, where the excess regenerated energy is dissipated in an external resistor, is recommended .

The Dynamic Braking is used in cases where short braking times are required or where high inertia loads are driven.

For Vector Control modes the “Optimal Braking” feature can be used and in many cases eliminate the need for Dynamic Braking. Refer to Chapter 6, Parameter **P151**.



**NOTE!**

If dynamic braking will be used, set **P151** to its maximum value.

8.10.1 DB Resistor Sizing

For a precise sizing of the dynamic braking resistor, application data, such as: deceleration time, load inertia and braking duty cycle must be considered.

The RMS current capacity of the inverter’s dynamic braking transistor must also be taken into account, as well as its maximum peak current, which defines the minimum resistance value (ohms) of the braking resistor. Refer to Table 8.12.

The DC Link voltage level at which dynamic braking is activated is defined by the Parameter **P153** – Dynamic Brake Level.

The braking resistor is defined according to the deceleration time, load inertia and resistive torque. In most cases a resistor with an ohmic value indicated on Table 8.12 and a power rating of 20% of the driven motor can be used.

Use Wire type resistors with suitable insulation to withstand the instantaneous current peaks.

For critical applications with very short braking times, high inertia loads (Ex: centrifuges) or with very short and frequent duty cycles, contact WEG, to define the most suitable resistor.

CFW-09 Model		Maximum Braking Current [A] <sup>(1)</sup>	P <sub>max</sub> [kW] <sup>(3)</sup>	RMS Braking Current [A] <sup>(2)</sup>	P <sub>rated</sub> [kW] <sup>(3)</sup>	Minimum recommended resistor [ohms]	Power Wiring (BR, -UD, +UD) mm <sup>2</sup> - AWG
Power Supply Voltage [V]	Rated Current [A]						
220-230	6	10	3.9	5	0.97	39	2.5 - 14
	7 and 10	15	6.1	7	1.3	27	2.5 - 14
	13 and 16	20	8.8	10	2.2	22	4.0 - 12
	24	26	10.1	13	2.5	15	6.0 - 10
	28	38	14.4	18	3.2	10	10 - 8
	45	45	17.4	22	4.2	8.6	10 - 8
	54	95	42.4	48	10.8	4.7	35 - 3
	70 and 86	120	47.5	60	11.9	3.3	50 - 1
380 and 400-415	105 and 130	180	71.3	90	17.8	2.2	95 - 3/0
	3.6 and 4	6	3.6	3.5	1.2	100	2.5 - 14
	5.5	8	5.5	4	1.4	86	2.5 - 14
	9 and 13	16	10.0	10	3.9	39	4.0 - 12
	16	24	15.6	14	5.3	27	6.0 - 10
	24	34	20.8	21	7.9	18	10 - 8
	30	48	34.6	27	10.9	15	10 - 8
	38 and 45	78	52.3	39	13.1	8.6	25 - 4
440-460 and 480	60 and 70	120	80.6	60	20.1	5.6	50 - 1
	86 and 105	180	126.4	90	31.6	3.9	95 - 3/0
	142	250	168.8	125	42.2	2,7	120 - 4/0
	3.6 and 4	6	4.3	3.5	1.5	120	2.5 - 14
	5.5	8	6.4	4	1.6	100	2.5 - 14
	9 and 13	16	12.0	10	4.7	47	4.0 - 12
	16	24	19.0	14	6.5	33	6.0 - 10
	24	34	25.4	21	9.7	22	10 - 8
500-525 and 575-600	30	48	41.5	27	13.1	18	10 - 8
	38 and 45	78	60.8	39	15.2	10	25 - 4
	60 and 70	120	97.9	60	24.5	6.8	50 - 1
	86 and 105	180	152.3	90	38.1	4.7	95 - 3/0
	142	250	206.3	125	51.6	3.3	120 - 4/0
	2.9 and 4.2	8,33	12	4.2	2.08	120	2.5 - 14
	7	10	10	5	2.5	100	2.5 - 14
	10	12.2	12.81	6.1	3.05	82	2.5 - 14
500-525 and 575-600	12	14,71	20.83	7.4	3.68	68	4.0 - 12
	14	14.71	15.3	7.4	3.68	68	2.5 - 14
	22, 27 and 32	66.67	337.5	33.33	16.67	15	95 - 3/0
	44 and 53	100	225	50	25	10	95 - 3/0
500-525 and 575-600	63 and 79	121.95	184.5	61	30.49	8,2	95 - 3/0

Table 8.12 - Recommended Braking Resistor

(1) The maximum current can be determined by:

$$I_{max} = \text{Value set at P153[V]} / \text{Resistor Ohms}$$

(2) The RMS braking current can be calculated by

$$I_{rms} = I_{max} \cdot \sqrt{\frac{t_{br}^{[min]}}{5}}$$

Where  $t_{br}$  corresponds to the sum of the braking times during the most severe 5 minute cycle.

(3)  $P_{max}$  and  $P_{rated}$  are the maximum peak and rated powers that the braking chopper can deliver. The resistor power must be sized according to the application braking duty cycle.

### 8.10.2 Installation

- ☑ Connect the braking resistor between the +UD and BR power terminals (refer to section 3.2.1);
- ☑ Make this connection with a twisted pair. Run this cable separately from any signal or control wire;
- ☑ Size the cable cross section according to the application, considering the maximum and RMS current;
- ☑ If the braking resistor is installed inside the inverter panel, consider the heat dissipated by the resistor when defining the panel ventilation;
- ☑ Set Parameter **P154** to the Ohms value of the DB resistor and Parameter **P155** to the resistor power rating in kW.



#### DANGER!

The CFW-09 provides an electronic thermal protection for the braking resistor to avoid overheating. The braking resistor and the transistor can be damaged if:

- ☑ They are not properly sized;
- ☑ Parameters P153, P154 and P155 are not properly set;
- ☑ The line voltage exceeds the maximum allowed value.

The electronic thermal protection provided by the inverter, if properly programmed, protects the DB resistor in case of overloads not expected during normal operation, but it does not ensure protection in case of a dynamic braking circuit failure.

In this case the only guaranteed method to avoid burning the resistor and eliminate risk of fire is the installation of a thermal overload relay in series with the resistor and/or the installation of a thermostat on the resistor body, wiring it in a way to disconnect the inverter power supply in case of overheating, as shown below:

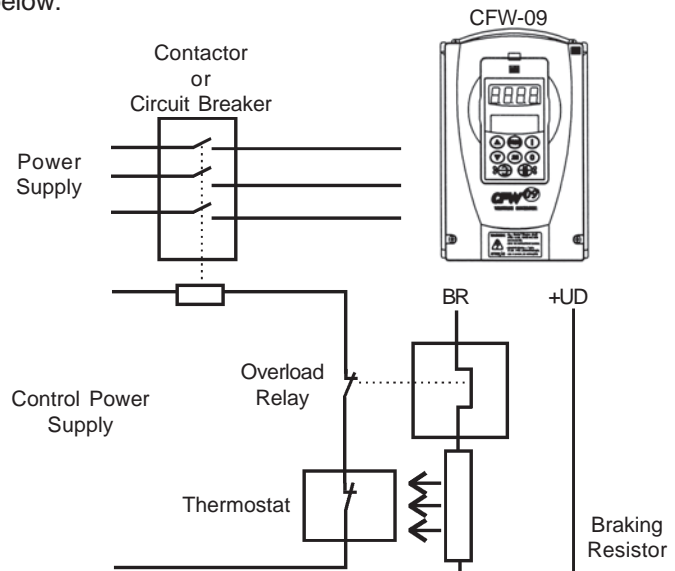

Figure 8.22 – Braking resistor connection



#### NOTE!

Through the power contacts of the bimetallic overload relay circulates Direct Current during the DC-Braking process.

8.10.3 Dynamic Braking module - DBW-01 and DBW-02 In the CFW-09 220-230V or 380-480V types with currents higher or equal to 180A, dynamic braking uses the DBW-01 external braking module. For 500-690V and 660-690V with currents higher or equal 100A, dynamic braking uses the DBW-02 external braking module.

Supply Voltage [V]	Inverter Types	Braking Module	Max. Braking Current A <sup>(1)</sup>	RMS Braking Current A <sup>(2)</sup>	Minimum Resistor Ω <sup>(3)</sup>	Power Wiring (BR, -UD,+UD) mm <sup>2</sup> (AWG)
380-480V	180A	DBW010165D21802SZ	200	165	4	70 (2/0)
	211A	DBW010240D21802SZ	320	240	2.5	120 (250 MCM)
	240A	DBW010240D21802SZ	320	240	2.5	120 (250 MCM)
	312A	DBW010300D21802SZ	400	300	2	2x50 (2x1/0)
	361A	DBW010300D21802SZ	400	300	2	2x50 (2x1/0)
	450A	DBW010300D21802SZ	400	300	2	2x50 (2x1/0)
	515A	DBW010300D21802SZ	400	300	2	2x50 (2x1/0)
	600A	DBW010300D21802SZ	400	300	2	2x50 (2x1/0)
500-690V / 660-690V	100A/107A	DBW020210D5069SZ	250	210	4.8	120( 250MCM)
	127A/147A	DBW020210D5069SZ	250	210	4.8	120 (250MCM)
	179A/211A	DBW020210D5069SZ	250	210	4.8	120 (250MCM)
	225A/247A	DBW020210D5069SZ	250	210	4.8	120 (250MCM)
	259A/315A	DBW020300D5069SZ	400	300	3	2x50 (2x1/0)
	305A/343A	DBW020300D5069SZ	400	300	3	2x50 (2x1/0)
	340A/418A	DBW020380D5069SZ	500	380	2.5	2x120 (2x250MCM)
	428A/472A	DBW020380D5069SZ	500	380	2.5	2x120 (2x250MCM)

Table 8.13 - Inverter and corresponding DBW

(1)The max. current can be calculated by:

$$I_{max} = \text{set value at P153[V]} / \text{value of the resistor [ohms]}.$$

(2)The rms braking current can be calculated by:

$$I_{rms} = I_{max} \cdot \sqrt{\frac{t_{br}^{[min]}}{5}} \quad \text{where } t_{br} \text{ corresponds to the sum of the braking}$$

actuation times during the most severe 5-minute cycle.

(3)The minimum resistor value of each shown model has been calculated so the braking current does not exceed the maximum current specified in table 8.13.

For this, following parameters have been considered

- DBW-01: rated line voltage = 480V.
- DBW-02: rated line voltage = 690V.
- Factory Standard Value of P153.

HOW TO SPECIFY THE DBW TYPE:

DBW-01	0165	D	2180	1	S	Z
WEG Braking Module: DBW-01	Rated Output Current: 220 to 480V: 0165=165A 0240=240A 0300=300A	DC Supply at Input	Input Supply Voltage: 2180=210 to 800 Vdc	Fan Supply Voltage: 1=110V rms 2=220V rms	Standard	Code End
DBW-02	0210=210A 0380=380A		5069=500 to 1200 Vdc			

8.10.3.1 DBW-01 and DBW-02 Identification Label

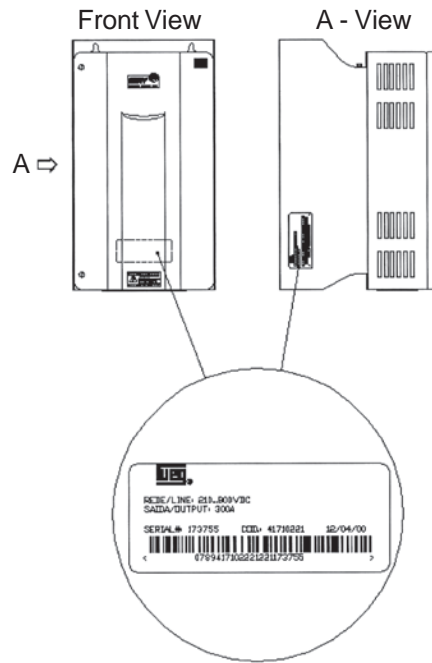
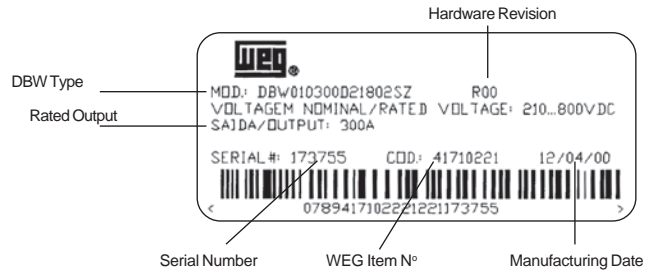

Figure 8.23 - Identification Label

8.10.3.2 Mechanical Installation

The environmental operating conditions of the DBW are the same as of the CFW-09 inverter (see item 3.1.1).

For panel installation, provide an additional airflow of 120 CFM (57 L/s) for cooling of the braking module.

When installing module, provide free spaces around the module, as shown in Figure 8.24, where A=100mm (4 in), B=40mm (1.57 in) and C=130mm (5.12 in).

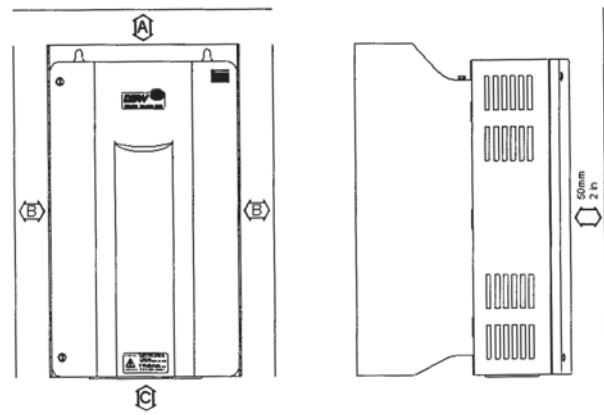
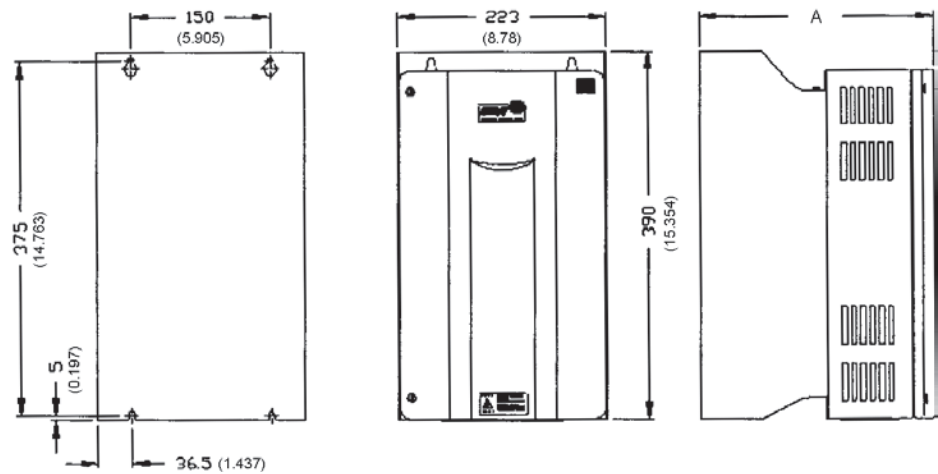

Figure 8.24 - Free Spaces for Cooling

Check the other recommendations for the CFW-09 inverter installation, since from the mechanical viewpoint, the module is compatible with CFW-09 frame size 3.

External dimensions and mounting holes are according to Figure 8.25.



Dimension A	DBW-01	DBW-02
mm (in)	252 (9.92)	277 (10.91)

Figure 8.25 - Dimensional Drawing of DBW-01 and DBW-02 - mm (inch)

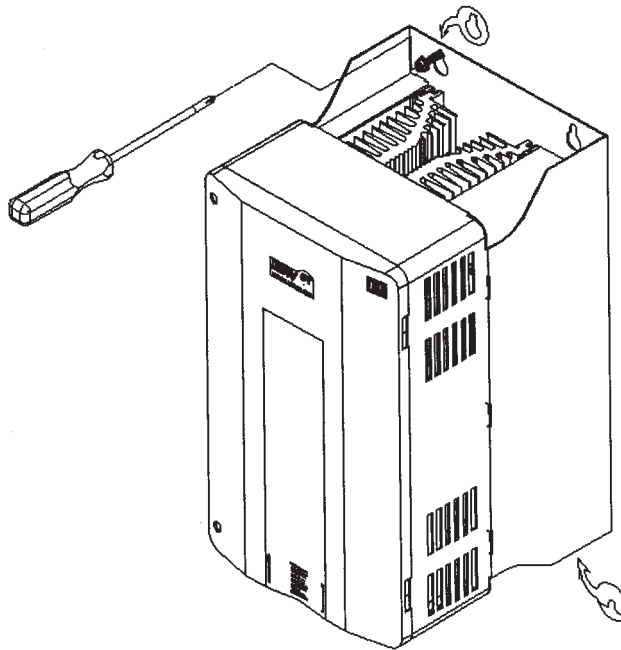

Figure 8.26 - Installation procedures for the DBW-01 and DBW-02 on surface

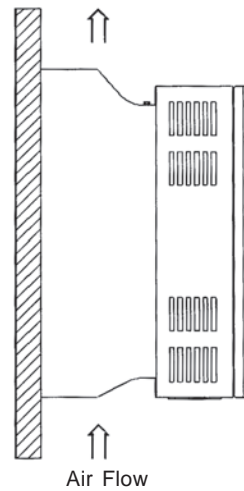

Figure 8.27 - DBW-01 and DBW-02 Positioning

The DBW-01 and DBW-02 can also be installed with a through surface mounting kit as described in item 8.11. In this case, use the available installation kit, which contains the respective installation supports. Figure 8.28 shows the mounting cutouts.

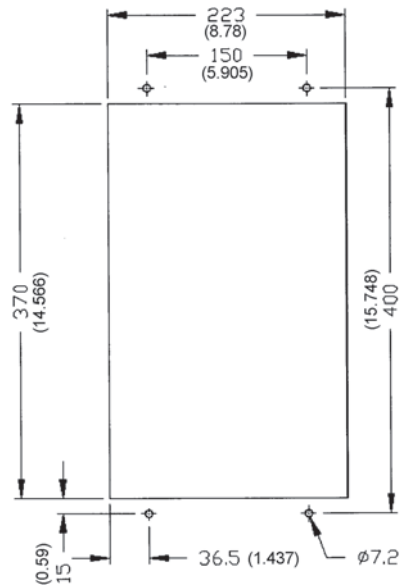

Figure 8.28 - Cutout dimensions in air duct - Dimensiones mm (inch)

Table 8.14 shows the weights of the different DBW-01 types.

Type	Fastening Screw	Weigth Kg	Degree of Protection
DBW-01 165	M6	14.2	IP20
DBW-01 240		13.8	
DBW-01 300		13.4	
DBW-02 210		14.2	
DBW-02 300		13.8	
DBW-02 380		13.4	

Table 8.14 - Mechanical Data of the DBW-01 and DBW-02

8.10.3.3 Installation/Connection Location of the power connections is shown in Figures 8.29, 8.30 and 8.31.

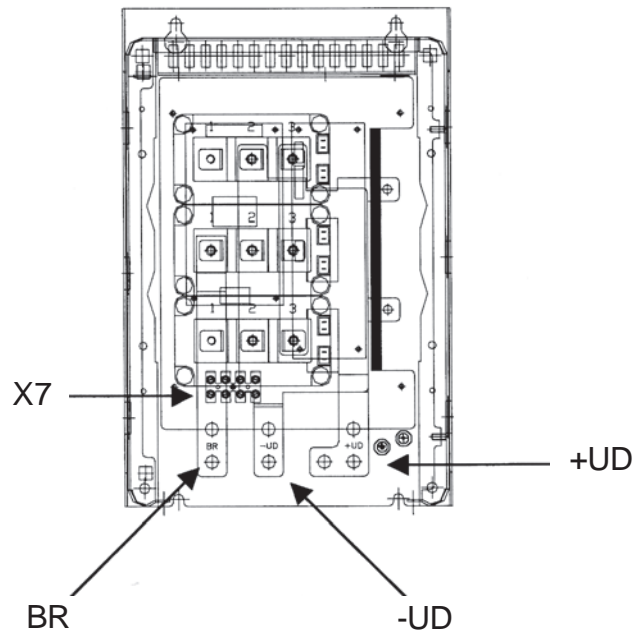

Figure 8.29 - Connection location

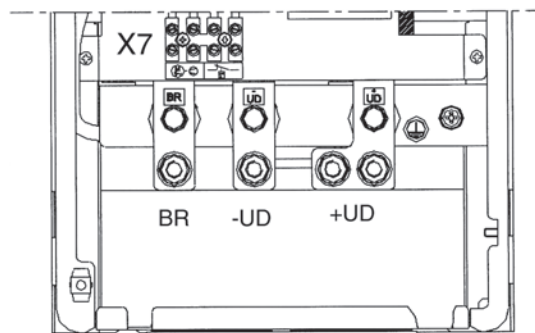

Figure 8.30 - Power terminals

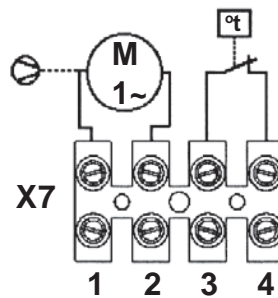

Figure 8.31 - X7 Terminal block

Supply the fan of the braking module with the suitable supply voltage (110 V or 120 V rms) at X7:1,2 connector (see Figure 8.32). The fan has a requires a current of about 0.14A. The terminals 3 and 4 of the terminal block X7 are the NC-contact of a thermostat that must be installed for the thermal protection of the braking module. This protection must be installed external to the braking module (see Figure 8.32); in this example, the relay is connected to DI3 (XC1:3,9 of the board CC9) and the parameter P265 is programmed as Without External Error (P265=4).

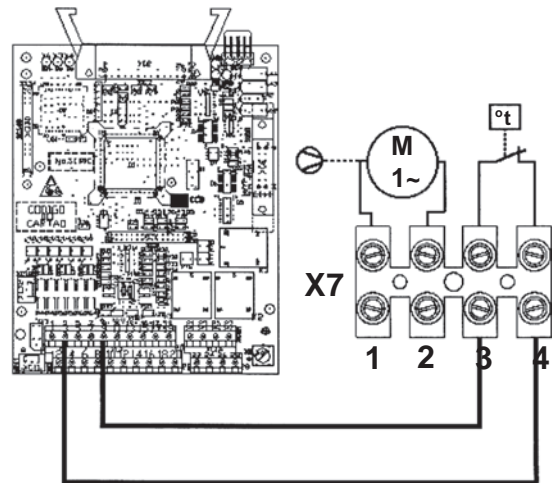

Figure 8.32 - Example of Thermal Protection

Connect the +UD grounding of the braking module to the +UD terminal of the inverter;

Connect the -UD grounding of the braking module to the -UD terminal of the inverter;

The control connection between the CFW-09 and the braking module is made through a cable (0307.7560). One end of this cable is connected to the XC3 connector that can be found at the CRG4 board (see figure 8.33 ) in the braking module. The other end of this cable is connected to a DB9 connector that is fastened to a metallic support at the side of the control board in the CFW-09.

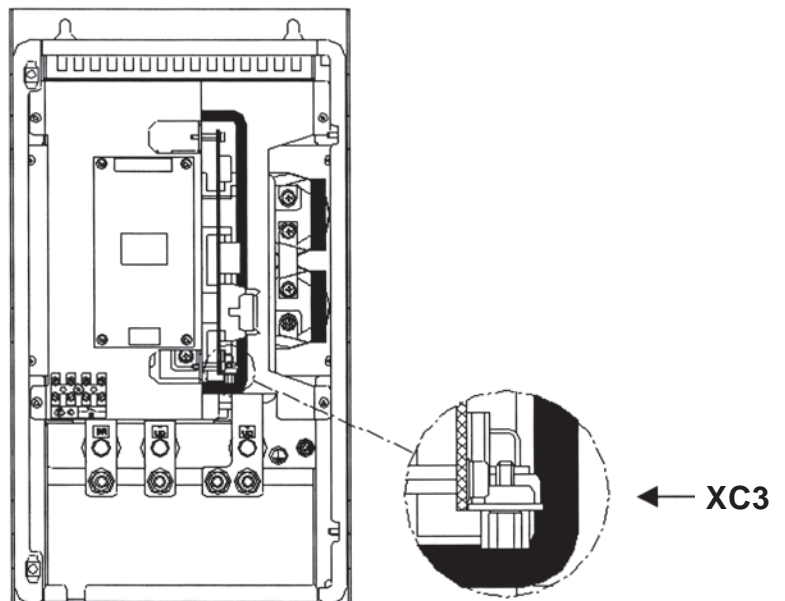

Figure 8.33 -Location of the XC3 connector

Figure 8.34 shows the connection of the braking module to the inverter, as well as the connections of the resistor to the braking module. It shows also the inclusion of a thermal relay and a thermostat in contact with the resistor body, thus ensuring its thermal protection. The connection cables between the inverter and the module and between the module the braking resistor must be dimensioned according to the thermal braking cycle.

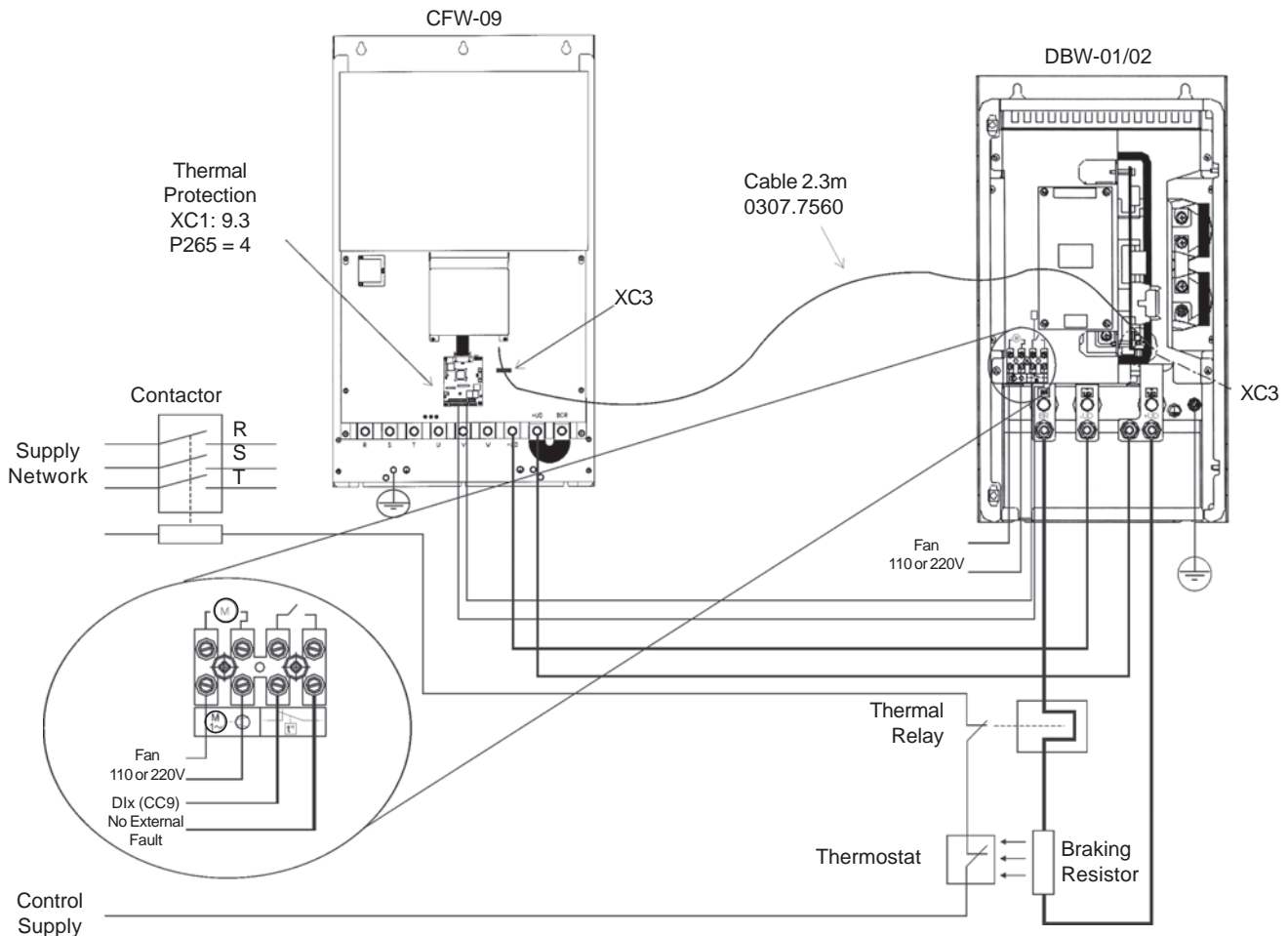

Figure 8.34 - Connections between the DBW, the CFW-09 and the Braking Resistor



**NOTE!**

- ☑ Through the power contacts of the bimetallic overload relay circulates Direct Current during the DC-Braking process.
- ☑ The DBW-02 has a duplicated XC3 connector (A and B). The XC3B is for connecting other DBW-02 module for parallel operation. It is possible to connect up to 3 DBW-02 modules in parallel. The interconnecting cable should be limited to 2 meters maximum cable length.

**8.11 THROUGH SURFACE MOUNTING KIT**

The kit for through surface mounting is composed of metallic supports that must be mounted on the rear of the CFW-09 frames 3 to 8 to allow through surface mounting. For further information refer to Section 3.1.3, Figure 3.4 and Table 3.4. Degree of protection is NEMA 1/IP20.

**8.12 FIELDBUS**

CFW-09 can be connected to fieldbus networks allowing its control and parameter setting. For this purpose you need to include an optional electronic board according to the desired Fieldbus standard: Profibus-DP, DeviceNet or Ethernet/IP.

8.12.1 Installation of the Fieldbus kit



**NOTE!**

The chosen Fieldbus option can be specified in the suitable field of the CFW-09 coding.  
 In this case the CFW-09 will be supplied with all needed components already installed in the product. For later installation you must order and install the desired Fieldbus kit (KFB).

The communication board that forms the Fieldbus Kit is installed directly onto the CC control board, connected to the XC140 connector and fixed by spacers.



**NOTE!**

- ☑ Follow the Safety Notices in Chapter 1
  - ☑ If a Function Expansion Board (EBA/EBB) is already installed, it must be removed provisionally. For the frame size 1 you must remove the lateral plastic cover of the product.
1. Remove the bolt from the metallic spacer near to the XC140 (CC9) connector.
  2. Connect carefully the pin connector of the Fieldbus board to the female connector XC140 of the CC9 control board. Check the exact coincidence of all pins of the XC140 connector (Figure 8.35).

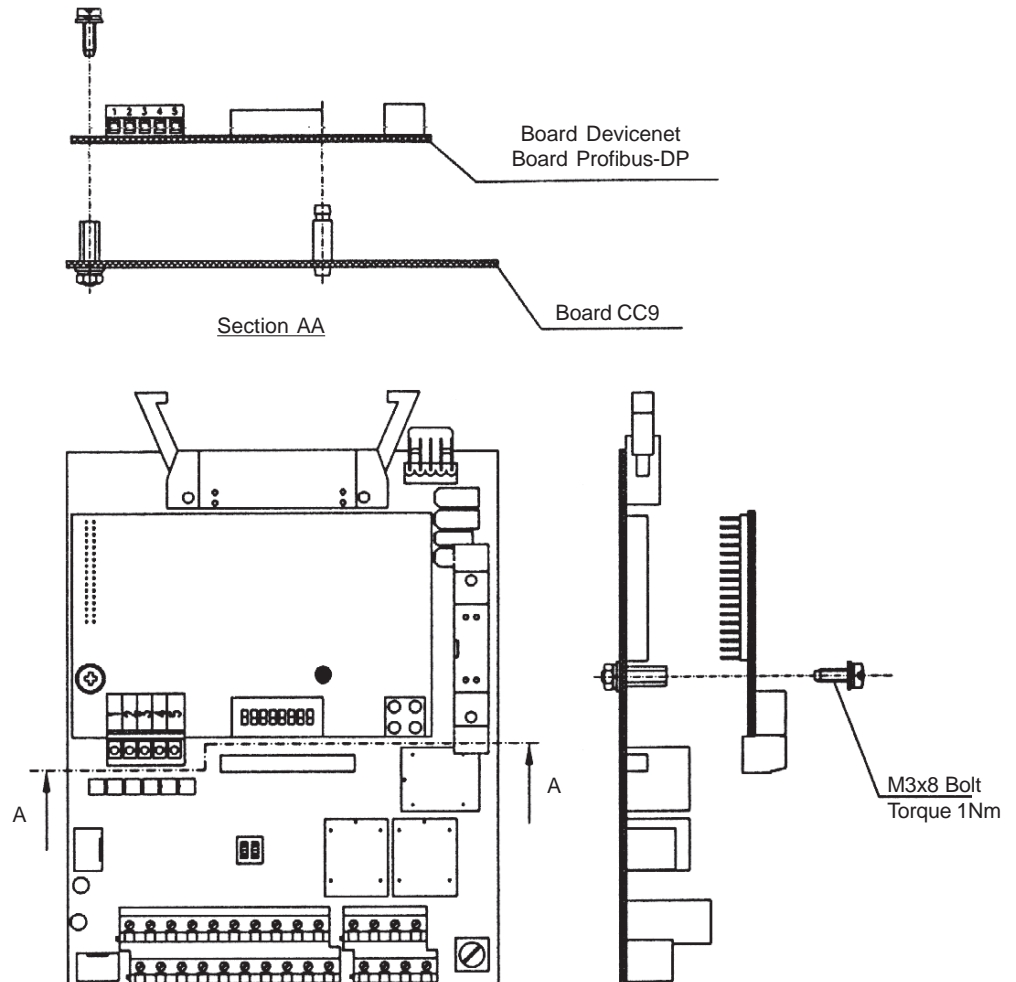

Figure 8.35 - Installation of the Electronic Board of the Fieldbus

3. Press the board near to XC140 and on the lower right edge until the connector and the plastic spacer is inserted completely;
4. Fix the board to the metallic spacer through the bolt (except ModBus RTU);
5. Fieldbus Connector:

**Sizes 1 and 2 (Models up to 28A):**

- Fix the Fieldbus connector to the inverter frame by using the 150 mm (5.9 in) cable (see figure 8.36).

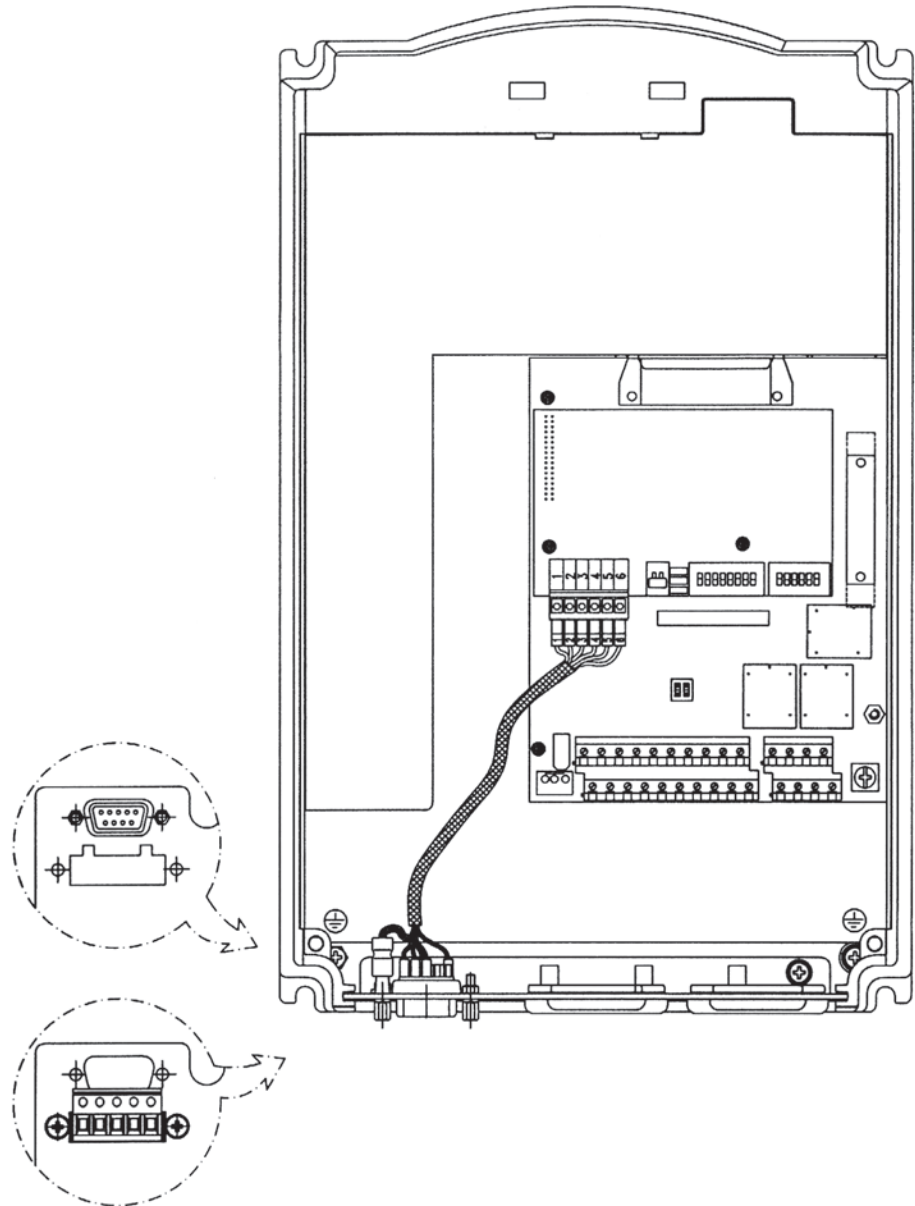
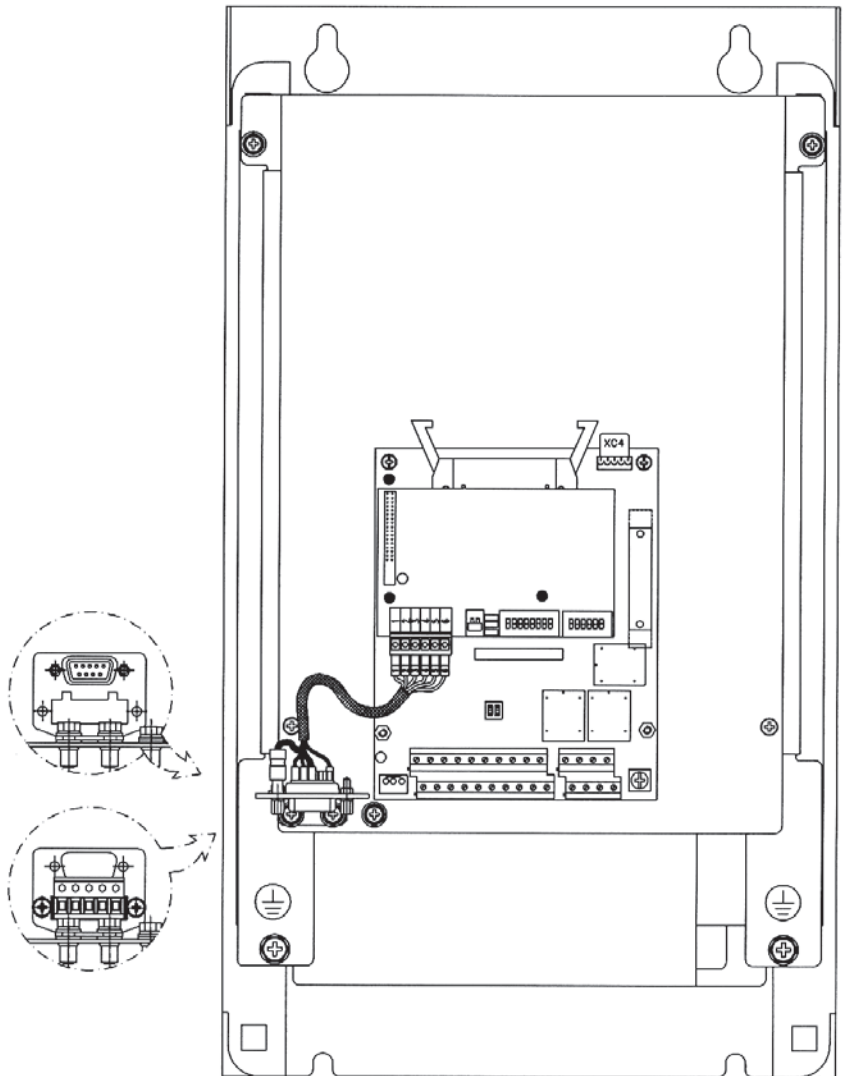

Figure 8.36 - Fastening of the Fieldbus connector

**Sizes 3 to 10 - (models up to 30A):**

- Connect the Fieldbus connector to the metallic “L” by using the 150mm (5.9 in).
- Fasten the set to the metallic support palte of the control board (see 8.37).



*Figure 8.37 - Fastening of the Fieldbus connector*

6. Connect the other cable end of the Fieldbus connector to the electronic Fieldbus board, as shown in Figure 8.38.

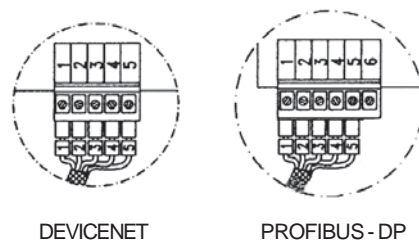

*Figure 8.38 - Connection to the Fieldbus board*

8.12.2 Profibus-DP

**Introduction**

The inverter that is fitted with the Profibus-DP Kit operates in slave mode, allowing the reading/writing of their parameters through a master. The inverter does not start the communication with other nodes, it only answers to the master controls. A twisted pair of copper cable realizes the connection of the Fieldbus (RS-485) allowing the data transmission at rates between 9.6kbits/s and 12Mbits/s. Figure 8.39 show a general view of a Profibus-DP network.

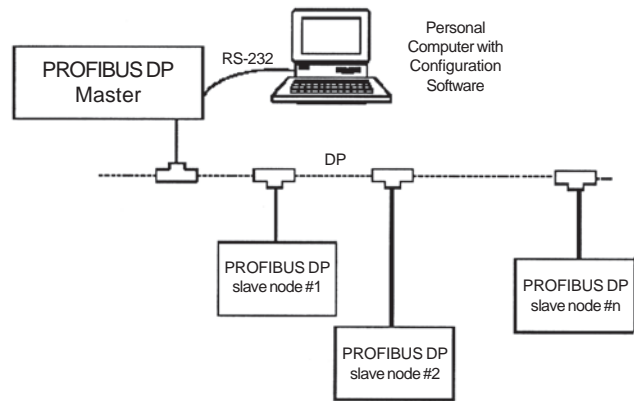

Figure 8.39 - Profibus-DP network

- Fieldbus Type: PROFIBUS-DP EN 50170 (DIN 19245)

**Physical Interface**

- Transmission means: Profibus bus bar line, type A or B as specified in EN50170
- Topology: Master-Slave communication
- Insulation: the bus is supplied by DC/DC inverter and isolated galvanically from remaining electronics and the signals A and B are isolated by means of optocouplers.
- It allows the connection/disconnection of only one node without affecting the network.

**Fieldbus connector of the inverter user**

- Connector D-sub 9 pins - female
- Pins:

Pin	Name	Function
1	Not connected	-
2	Not connected	-
3	B-Line	RxD/TxD positive, according to specification RS-485
4	Not connected	-
5	GND	0V isolated against RS-485 circuit
6	+ 5V	5V isolated against RS-485 circuit
7	Not connected	-
8	A-Line	RxD/TxD negative, according to specification RS-485
9	Not connected	-
Frame	Shield	Connected to the ground protection (PE)

Table 8.15 - Pin connection (DB9) to the Profibus-DP

**Line Termination**

The initial and the en points of the network must be terminated with the characteristic impedance in order to prevent reflections. The DB 9 cable male connector has the suitable termination. When the inverter is the first or the last of the network, the termination switch must be set to Pos. "ON". Otherwise set the switch to Pos. "OFF". The terminating switch of the PROFIBUS DP board must be set to 1 (OFF).

**Transfer Rate (baud rate)**

The transfer rate of a Profibus-DP network is defined during the master configuration and only one rate is permitted in the same network. The Profibus-DP board has an automatic baud rate detection and the user does not need to configure it on the board. The supported baudrates are: 9.6 kbits/s, 19.2 kbits/s, 45.45 kbits/s, 93.75 kbits/s, 187.5 kbits/s, 500 kbits/s, 1.5 Mbits/s, 3 Mbits/s, 6 Mbits/s and 12 Mbits/s.

**Node Address**

The node address is established by means of two rotating switches on the electronic Profibus-DP board, permitting the addressing from 1 to 99 addresses. Looking onto the front view of the board with the inverter in normal position, the switch at left sets the ten of the address, while the left switch sets the unit of the address:

$$\text{Address} = (\text{set left rotary switch} \times 10) + (\text{set right rotary switch} \times 1)$$



**NOTE!**

The node address can not be changed during operation.

**Configuration File (GSD File)**

Each element of a Profibus-DP network is associated to a GSD file that has all information about the element. This file is used by program of the network configuration. Use the file with the extension .gsd stored on the floppy disk contained in the Fieldbus kit.

**Signaling**

The electronic board has a bicolor LED at right topside indicating the status of the Fieldbus according to the table 8.16 and figure 8.40 below:

Color LED	Frequency	Status
Red	2Hz	Fault during the test of the ASIC and Flash ROM
Green	2Hz	Board has not been initialized
Green	1Hz	Board has been initialized and is operating
Red	1Hz	Fault during the RAM test
Red	4Hz	Fault during the DPRAM test

*Table 8.16 - Signaling LED of the Fieldbus board status*



**NOTE!**

The red fault indications mean hardware problems of the electronic board. The reset is realized by switching OFF / ON the inverter. If the problem persists, replace the electronic board.

The electronic board is also fitted with four other bicolor LED's placed at the right bottom side, indicating the Fieldbus status according to the Figure below:

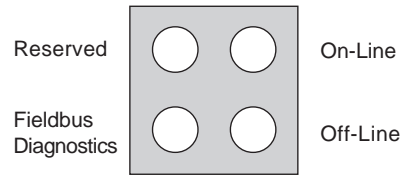

Figure 8.40 - LED's indicating the status of the Profibus-DP network

LED	Color	Function
Fieldbus Diagnostics	Red	Indicates certain faults at the Fieldbus: <b>Flashing 1Hz - Configuration error:</b> the IN/OUT area size set at board enabling is different from the size set during the network configuration. <b>Flashing 2Hz - Error in the User's Parameter Data:</b> the size/content of the User Parameter data set at board enabling is different from the size/content set during the network configuration. <b>Flashing 4Hz - Enabling error of the Profibus Communication ASIC.</b> <b>OFF - no problems.</b>
On-Line	Green	Indicates that the board is On-line at the Fieldbus <b>ON</b> - the board is off-line and the data exchange is not possible. <b>OFF</b> - the board is not On-line.
Off-Line	Red	Indicates that the board is Off-line at the Fieldbus <b>ON</b> - the board is off-line and the data exchange is not possible. <b>OFF</b> - the board is not Off-line.

Table 8.17 - Signaling LED's indicating the status of the Profibus-DP network



**NOTE!**

When power is applied to the drive and both on-line and off-line LED's on the Profibus DP board keep flashing, then a network address configuration or installation problem may be present. Check the installation and the network node address.



**NOTE!**

Use of the Profibus-DP/related CFW-09 Parameters. See item 8.12.5.

8.12.3 DeviceNet

**Introduction**

The DeviceNet communication is used for industrial automation, mainly for the control of valves, sensors, input/output units and automation equipment. The DeviceNet communication link is based on a communication protocol "broadcast oriented", the Controller Area Network (CAN). The connection to the DeviceNet network is realized by means of a shielded cable comprising a twisted pair and two wires for the external power supply. The baud rate can be set to 125kbits/s, 250kbits/s or 500kbits/s. Figure 8.41 gives a general view of a DeviceNet network.

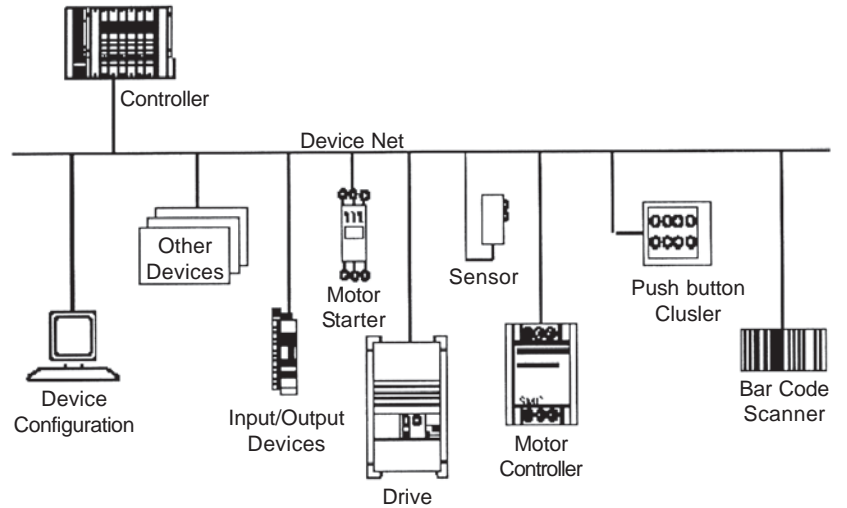

Figure 8.41 - DeviceNet Network



**NOTE!**

The PLC (master) must be programmed to Polled I/O connection.

**Fieldbus connector of user of the inverter**

- Connector: 5 ways-connector of type plug-in with screwed terminal (screw terminal)
- Pin:

Pin	Description	Color
1	V-	Black
2	CAN_L	Blue
3	Shield	-
4	CAN_H	White
5	V+	Red

Table 8.18 - Connection of the pins to the DeviceNet

**Line Termination**

To avoid reflection, the initial and the end points of the network must be terminated with the characteristic impedance. Thus a 120-ohms/0.5W resistor must be connected between the pins 2 and 4 of the Fieldbus connector.

**baud rate/ Node Address**

There are three different baudrates for the DeviceNet: 125kbits/s, 250kbits/s or 500kbits/s. Choose one of these baudrates by setting the DIP switches on the electronic board.

The node address is selected through the six DIPswitches on the electronic board, permitting an addressing from 0 to 63 addresses.

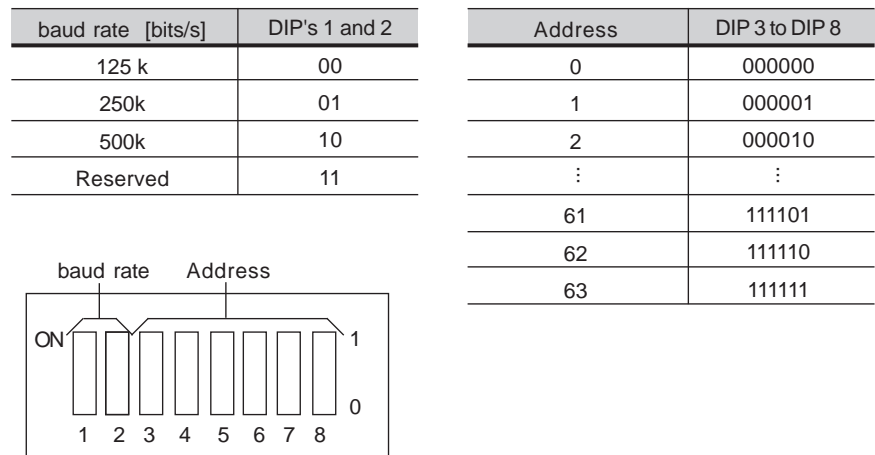

Figure 8.42 - baud rate configuration and addressing to the DeviceNet

**Configuration File (EDS File)**

Each element of a DeviceNet network is associated to a EDS file, that has all information about the element. This file is used by program of the network configuration during its configuration. Use the file with the extension .eds stored on the floppy disk contained in the Fieldbus kit.

Setting parameter P309 to 4, 5 or 6 selects 2, 4 or 6 input/output words (see item 8.12.5).

With the assistance of the network configuration software define the number of words for the device according to the value set on parameter P309. The type of connection used for data exchange shall be set for "Polled I/O".



**NOTE!**

The PLC (master) must be programmed for Polled I/O connection.

**Signaling**

The electronic board has a bicolor LED at right topside indicating the status of the Fieldbus according to the table 8.16.

**Note:**

The red fault indications mean hardware problems of the electronic board. The reset is realized by switching OFF / ON the inverter. If the problem persists, replace the electronic board.

The electronic board is also fitted with other four bicolor LED's placed at the right bottom side, indicating the DeviceNet status according to Figure 8.43 and Table 8.19:

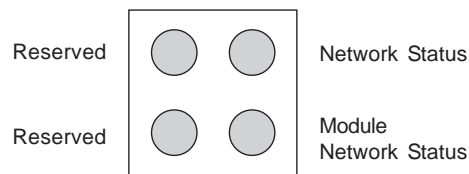

Figure 8.43 - LED's for status indication of the DeviceNet network

LED	Color	Description
Module Network Status	ON	Without supply
Module Network Status	Red	Fault not recoverable
Module Network Status	Green	Board operating
Module Network Status	Red Flashing	Smaller fault
Network Status	Off	Without supply/off line
Network Status	Green	Link operating, connected
Network Status	Red	Critical fault at link
Network Status	Green Flashing	On line not connected
Network Status	Red Flashing	Time out of the connection

Table 8.19 - Signaling LED's indicating the DeviceNet status



**NOTE!**

Use of the DeviceNet /related CFW-09 Parameters. See item 8.12.5.

8.12.4 EtherNet/IP

EtherNet/IP (Industrial Ethernet Protocol) is a communication system proper for the industrial environment. This system allows application data exchange, time-restricted or critical, between industrial systems. The EtherNet/IP is available for simple devices such as sensors/actuators as well as for complex devices such as robots, PLCs, keypads and drives.

The Ethernet/IP application layer protocol is based on the Control and Information Protocol (CIP) layer that is used in both DeviceNet™ and ControlNet™. The CIP organizes the devices as collection of objects and defines the methods and procedures for data access. Furthermore, the Ethernet/IP uses the standard IEEE 802.3 for the low level layers and the TCP/IP and UDP/IP protocols for the intermediary layers to transport the CIP packets.

Therefore, the infrastructure used by the EtherNet/IP is the same used by the corporate computer networks (Ethernet). This fact extends considerably the means of controlling and monitoring the devices connected to the network:

- % Availability of application protocols (HTTP, FTP, etc.).
  - % Integration between the factory floor network and the corporate network.
  - % It is based on a widely used and accepted standard.
- Greater data flow than the standard protocols used for the industrial automation.

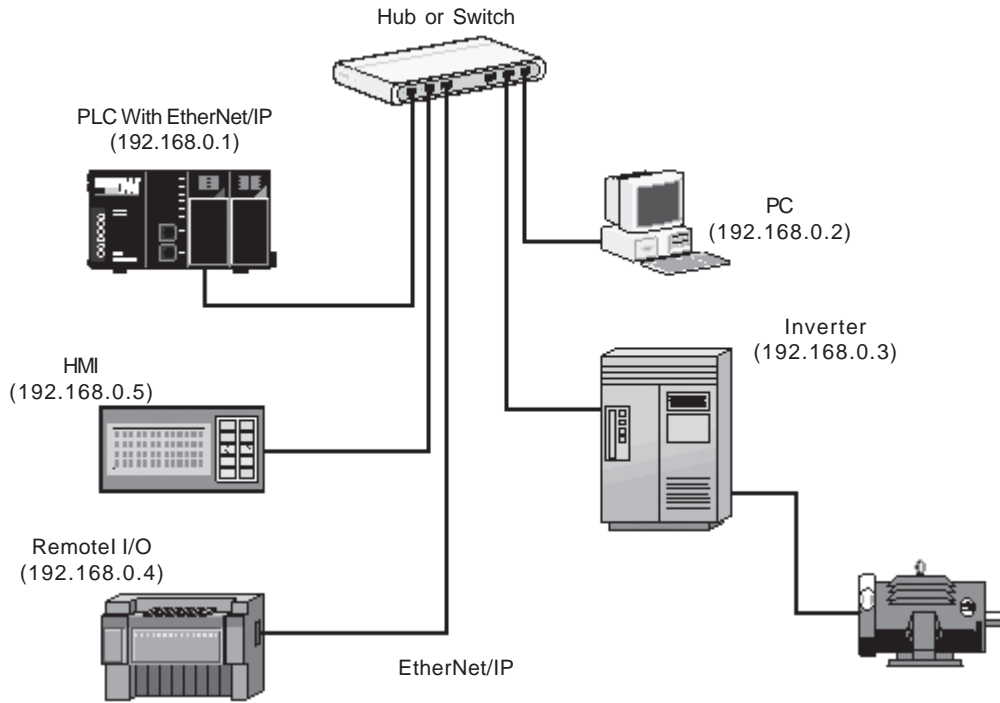

Figure 8.44 - Example of an EtherNet/IP Network

**Fieldbus Connector**

- Connector: RJ-45 connector with 8-pin.
- Pinout: two standards for straight-through cables are available: Ethernet: T-568A and T-568B. The function of each pin is shown in table 1. The cable to be used with the CFW-09 shall follow one of these two standards. Furthermore, only one standard shall be used for the cables, i.e., the connectors of both cable ends shall be crimped according to standard T-568A or T-568B.

a) RJ-45 Plug - T-568A Standard

Pino	Cable Color	Signal
1	White/Green	TX+
2	Green	TX-
3	White/Orange	RX+
4	Blue	-
5	White/Blue	-
6	Orange	RX-
7	White/Brown	-
8	Brown	-

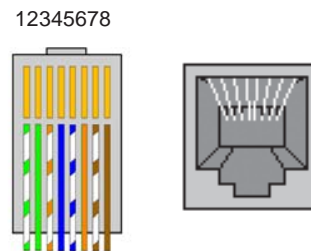

b) RJ-45 Plug - T-568B Standard

Pin	Cable Color	Signa
1	White/Orange	TX+
2	Orange	TX-
3	White/Green	RX+
4	Blue	-
5	White/Blue	-
6	Green	RX-
7	White/Brown	-
8	Brown	-



Figura 8.45 a) b) - Straight-Through Ethernet Cables

**Line Termination**

With the Ethernet 10BASE-T (10Mbps) or 100BASE-TX (100Mbps) the line termination is already on the communication board and also on any other device that uses a point-to-point twisted pair cable. Therefore, no additional setting is needed for the CFW-09.

**Communication Bit-rate**

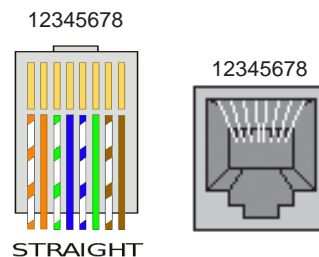
The CFW-09 can operate in an Ethernet network at 10Mbps or 100Mbps and also in half-duplex or full-duplex modes. When operating at 100Mbps in full-duplex mode, the effective rate doubles to 200Mbps. These configurations are performed through the network configuration and programming software. No board setting is needed. It is recommended to use the auto-sensing resource.

**Configuration File (EDS file)**

Each device on an EtherNet/IP network is associated to an EDS file that contains information about the device operation. The EDS file provided along with the product is used by the network configuration software.

**Indication**

The communication board has four two-color LEDs located on the right bottom corner to indicate the module and the network status.

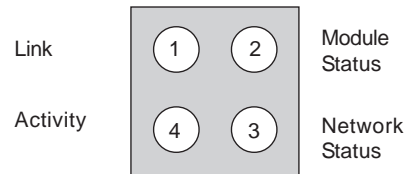

Figure 8.46 - Indication LEDs for the status of the EtherNet/IP network

LED	Color	Function
Link	Green	<b>On:</b> the module is connected to another device on the network (typically a hub or switch). <b>Off:</b> the module is not connected to another device.
Module Status	Green or Red	<b>Steady Off:</b> No power applied o the module.
		<b>Steady Green:</b> The module is operating correctly.
		<b>Flashing Green:</b> the module has not been configured.
		<b>Flashing Red:</b> A minor recoverable error has been detected.
		<b>Steady Red:</b> A major internal error has been detected.
Network Status	Green or Red	<b>Steady Off:</b> The module has no power or no IP address has been assigned.
		<b>Steady On:</b> the module has at least one established Ethernet/IP connection.
		<b>Flashing Green:</b> There are no Ethernet/IP connections established to the module.
		<b>Flashing Red:</b> One or more of the connections in which this module is the target has timed out.
		<b>Steady Red:</b> The module has detected that its IP address is already in use.
Activity	Green	<b>Flashing:</b> indicates that a packet has been received and/or transmitted.



**NOTE!**

The communication board that comes with the product has been developed by the HMS Industrial Networks AB company. Therefore, the network configuration software will not recognize the product as the CFW-09 variable frequency drive, but as the “Anybus-S EtherNet/IP” at the “Communication Adapter”. The differentiation among several CFW-09 drives will be based on the device address on the network.

**Related errors**

The EtherNet/IP uses the same error codes as the other Fieldbus protocols, i.e., E29 and E30.

**E29:** Fieldbus communication is off.

**E30:** Communication board is off.

For detailed information refer to the item 8.12.5.3.



**NOTE!**

The drive will indicate E29 only when the connection with the master is lost. The drive will not indicate this error while no connection has been established.

**Control and Monitoring through the WEB**

The EtherNet/IP communication board has an HTTP server internally. This means that the communication board can serve HTML pages. In such a way, it is possible to configure network parameters, control, and monitor the CFW-09 drive through a WEB browser installed in a computer connected to the same network of drive. Use the same read/write variables of the drive to perform these operations (refer to items 8.12.5.1 and 8.12.5.2).



**NOTE!**

For the first WEB access use the factory default username and password.

Username: *web*

Password: *web*

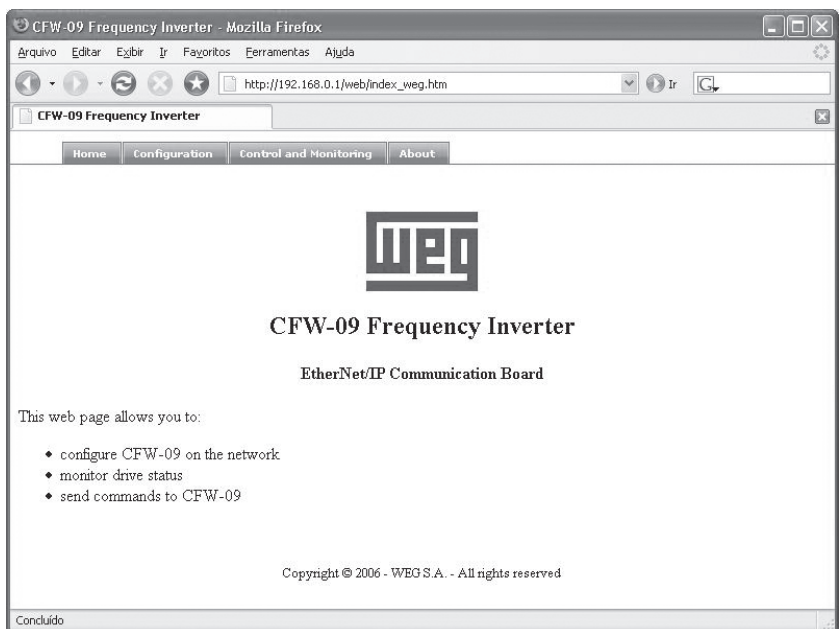

Figure 8.47 - Open window when accessing the CFW-09 through the WEB

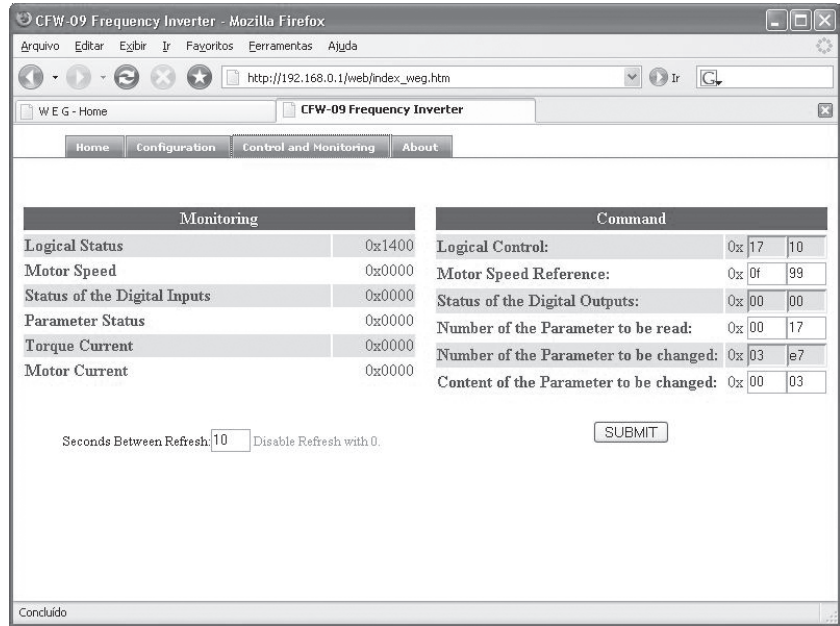

Figure 8.48 - Control and Monitoring window when accessing the CFW-09 through the WEB



**NOTE!**

It is necessary to have a PC with an Ethernet card connected to the same network of the CFW-09 and a WEB browser (MS Internet Explorer or Mozilla/Firefox).

**Configurations**

Follow the steps below to operate the CFW-09 in an EtherNet/IP network.

- 1) Install the KFB-EN kit into the CFW-09 variable frequency drive.
- 2) At parameter P309 select the EtherNet/IP protocol and the number of input/output words, P309 = 7, 8 or 9.
- 3) Connect the RJ-45 plug of the Ethernet cable to the drive and make sure that the Link LED is ON (LED 1).
- 4) Open your WEB browser and type the drive address on the network. The factory default value is '<http://192.168.0.1>'. Make sure that JavaScript and cookies are enabled in the WEB browser.

The data access is protected by username and password. The CFW-09 has the following factory default values: Username: *web* Password: *web*

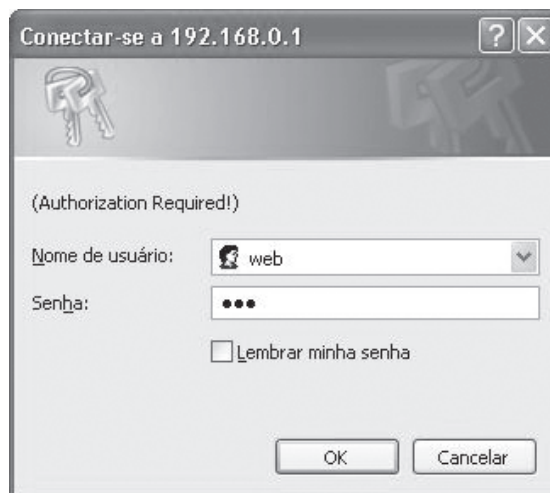

- 5) At the 'Configuration' tab of the WEB page shown in figure X set, if needed, the 'Network Parameters'. Set also the value of parameter P309.
- 6.1) If the drive address on the network belongs to the reserved range '192.168.0.X', it is possible to use the DIP-switches of the communication board for addressing purposes. In this case, the DIP-switch represents the binary value of the last byte in the IP address.

Example:

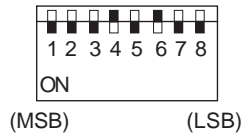

The DIP-switch is set to 00010100 (20 in decimal format).  
Thus, the drive address on the network is 192.168.0.20.

- 6.2) If the drive has an IP address out of the default range (192.168.0.X), deactivate the hardware addressing by setting the DIP-switches to zero (00000000).
  - 6.3) If the network addressing is performed through a DHCP server, select the box 'DHCP enabled' and set the DIP-switches to zero (00000000).
- 7) Click on the button 'STORE CONFIGURATION' to save the new settings.  
Restart the CFW-09

**Access to the communication board**

The communication board supports FTP and Telnet services. In such a way, it is possible to upload/download files to/from the board and also access the file system in an interactive way.

In order to use these services follow the steps below:

- Open a MS-DOS command window.
- Type the desired service (FTP or Telnet) followed by the IP address or hostname of the CFW-09 on the network.
- Entre com: Nome do usuário: *user* Senha: *user*

Examples:

Telnet session for the CFW-09 with IP address 192.168.0.4.

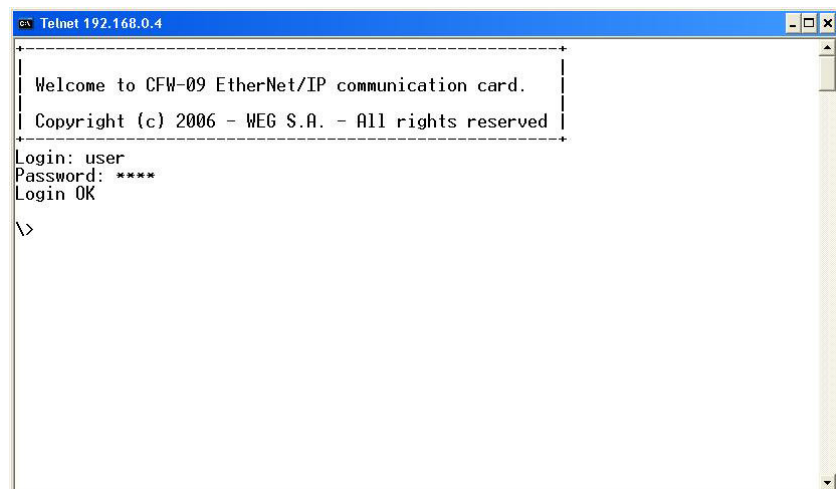

FTP session for the CFW-09 whit IP address 192.168.0.4.

```

C:\WINDOWS\system32\cmd.exe - ftp 192.168.0.4
C:\>ftp 192.168.0.4
Conectado a 192.168.0.4.
220 Service ready
Usuário (192.168.0.4:(none)): user
331 User name ok, need password
Senha:
230 User logged in
ftp> _

```

### Security and access passwords

The file system of the communication board has two security levels for the user: **admin** and **normal**.

It is only permitted to connect in the **normal** mode. In this case, the users are restricted to the directory 'user\'', where it is possible to create or delete files and/or folders. The accounts for normal users are defined in the file 'sys\_pswd.cfg' that is located under directory 'user\pswd\''. Each line of the file has a pair 'login:password' that corresponds to a user account.

In order to change the file containing the user accounts, create, with the assistance of a simple text editor, a file that contains in each line a pair 'login:password'. A colon shall separate the two words. Notice that no password cryptography is available, i.e., the login and the password are completely visible. After creating/modifying the user accounts, transfer via FTP the file 'sys\_pswd.cfg' to the directory 'user\pswd\'.

Example of file transfer through FTP:

```

C:\WINDOWS\system32\cmd.exe - ftp 192.168.0.4
C:\>ftp 192.168.0.4
Conectado a 192.168.0.4.
220 Service ready
Usuário (192.168.0.4:(none)): user
331 User name ok, need password
Senha:
230 User logged in
ftp> cd pswd
200 directory changed to \pswd
ftp> dir
200 Command OK
150 Listing files.
-rw-rw-rw- 0 root root          9 Jan 1 01:01 sys_pswd.cfg
-rw-rw-rw- 0 root root          9 Jan 1 01:01 web_pswd.cfg
226 Transfer OK, Closing connection
ftp: 124 bytes recebidos em 0,16Segundos 0,80Kbytes/s.
ftp> put sys_pswd.cfg
200 Command OK
150 Connecting for STOR
226 Transfer OK, Closing connection
ftp: 9 bytes enviados em 0,00Segundos 9000,00Kbytes/s.
ftp> _

```



### NOTE!

The CFW-09 that comes from the factory has a **normal** user account:

Username: *user*

Password: *user*

Users of the **normal** security level are restricted to the directory 'user\'.

In addition to the access control for the file system, there is also an access control for the HTML pages of the communication board. The file containing the access passwords is located under the directory 'user\pswd', and it is named 'web\_accs.cfg'. As in the previous case, each line of the 'web\_accs.cfg' file represents an access account. In order to change the user accounts for the HTML pages, create a text file with the same name ('web\_accs.cfg') and insert in each line of this file a pair 'login:password' for the users with access permission. After that, transfer this new file through FTP to the communication board, exactly as in the previous case.



**NOTE!**

It is strongly recommended to change all passwords of the EtherNet/IP communication board after the start-up of the device. The new passwords will be effective only after powering down and up the CFW-09.



**NOTE!**

When the drive returns from the *offline* state the output values are reset.

8.12.5 Use to the Fieldbus/  
Related Parameters  
of the CFW-09

☑ There are two main parameters: P309 and P313.

**P309** - defines the used standard Fieldbus (Profibus-DP, DeviceNet) and the number of variables (I/O) exchanged with the master (2, 4 or 6). The parameter P309 has the following options:

- |                        |                      |
|------------------------|----------------------|
| 0 = Inactive,          |                      |
| 1 = Profibus DP 2 I/O, | 4 = DeviceNet 2 I/O, |
| 2 = Profibus DP 4 I/O, | 5 = DeviceNet 4 I/O, |
| 3 = Profibus DP 6 I/O, | 6 = DeviceNet 6 I/O, |
| (for Profibus-DP),     | (for Device Net).    |

**P313** - defines the inverter behavior when the physical connection with the master is interrupted and/or the Fieldbus board is inactive (E29/E30).

- The parameter P313 has the following options:

- 0 = Disables the inverter by using the Start/Stop controls via deceleration ramp.
- 1 = Disables the inverter by using the General Enabling, stop by inertia.
- 2 = The inverter status is not changed.
- 3 = The inverter goes to Local mode.
- 4 = The drive changes to Local mode keeping the commands and the reference.

8.12.5.1 Variables Read  
from the Inverter

- 1 - Logical Status of the inverter,
- 2 - Motor speed,  
For the option P309 = 1 or 4 (2I/O) - read 1 and 2,
- 3 - Status of the Digital Inputs(P012)
- 4 - Parameter Status,  
For the option P309 = 2 or 5 (4I/O) - it reads 1, 2, 3 and 4,
- 5 - Torque current (P009),
- 6 - Motor current (P003),  
For the option P309 = 3 or 6 (6I/O) - it reads 1, 2, 3, 4, 5 and 6.

**1. Logical Status (E.L.):**

The word that defines the E.L. is formed by 16 bits, being 8 bits of high order and 8 bits of low order. It has the following construction:

**High-Order Bits** - they indicate the status of the associated function

- EL.15 - Active error: 0 = No, 1 = Yes;
- EL.14 - PID Regulator 0 = Manual, 1 = Automatic;
- EL.13 - Undervoltage : 0 = Without, 1 = with;
- EL.12 - Local/Remote Control: 0 = Local, 1 = Remote;
- EL.11 - JOG Control: 0 = Inactive, 1 = Active;
- EL.10 - Direction of rotation: 0 = Counter-Clockwise, 1 = Clockwise;
- EL.09 - General Enabling: 0 = Disabled, 1 = Enabled;
- EL.08 - Start/Stop: 0 = Stop, 1 = Start.

**Low-Order Bits** - they indicate the error code number, (i.e. 00, 01, ... ,09, 11(0Bh), 12(0Ch), 13(0Dh), 24(18h), 32(20h) and 41(29h) ). See Item 7.1- Faults and Possible Causes.

**2. Motor Speed:**

This variable is shown by using the 13-bit resolution plus signal. Thus the rated value will be equal to 8191(1FFFh)(clockwise rotation) or -8191(E001h) (counter-clock wise rotation) when the motor is running at synchronous speed (or base speed, for instance 1800rpm for IV-pole motor, 60Hz).

**3. Status of the Digital Inputs:**

Indicates the content of the Parameter P012, where the level 1 indicates active input (with +24V) , and the level 0 indicates the inactive input (with 0V). See Item 6.1-Access and Read Parameter. The digital inputs are so distributed in this byte:

- |                    |                     |
|--------------------|---------------------|
| Bit.7 - DI1 status | Bit.3 - DI5 status  |
| Bit.6 - DI2 status | Bit.2 - DI6 status  |
| Bit.5 - DI3 status | Bit.1 - DI7 status  |
| Bit.4 - DI4 status | Bit.0 - DI8. status |

**4. Parameter Content:**

This position permits to read the inverter parameter contents that are selected at Position 4. Number of parameter to be read from the “Variables Written in the Inverter”. The read values will have the same order as described in the product Manual or shown on the HMI .

The values are read without decimal point, when it is the case. Examples:

- a) HMI displays 12.3, the read via Fieldbus will be 123,
- b) HMI displays 0.246, the read via Fieldbus will be 246.

There are some parameters which representation on the 5 segment display can suppress the decimal point when the values are higher than 99,9. These parameters are: P100, P101, P102 , P103, P155, P156, P157, P158, P169 (for P202=0,1,2 and 5), P290 and P401.

Example: Indication on the 7 segment display: 130.,  
 Indication on the LCD display LCD : 130.0, the read value via Fieldbus is: 1300.

The read of the Parameter P006 via Fieldbus has the following meaning:

- 0 = ready;
- 1 = run;
- 2 = Undervoltage;
- 3 = with fault, except E24 to E27.

**5. Torque Current:**

This position indicates de P009 Parameter content, disregarding the decimal point. A lowpass filter with a time constant of 0.5 s filters this variable.

**6. Motor Current:**

This position indicates de P003 Parameter content, disregarding the decimal point. A lowpass filter with a time constant of 0.3 s filters this variable.

8.12.5.2 Variables Written in the Inverter

The variables are written in the following order:

- 1 - Logical Control,
- 2 - Motor speed reference,  
for option P309 = 1 or 4 (2I/O) - it writes in 1 and 2;
- 3 - Status of the Digital Outputs;
- 4 - Number of the Parameter to be read,  
for option P309 = 2 or 5 (4I/O) - it writes in 1, 2, 3 and 4;
- 5 - Number of the Parameter to be changed;
- 6 - Content of the Parameter to be changed, selected in the previous position,  
for option P309 = 3 or 6 (6I/O) - it writes in 1, 2, 3, 4, 5 and 6.

**1. Logical Control (C.L.):**

The word that defines the C.L. is formed by 16 bits, being 8 bits of high orders and 8 bits of low orders and having the following construction:

**High-Order Bits** - they select the function that shall be driven when the bit is set to 1.

- CL.15** - Inverter fault reset;
- CL.14** - Without function;
- CL.13** - To save the changes of the parameter P169/P170 in the EEPROM;
- CL.12** - Local/Remote control;
- CL.11** - Jog control;
- CL.10** - Direction of rotation;
- CL.09** - General enabling;
- CL.08** - Start/Stop.

**Low-Order Bits** - they determine the status that is wanted for the function selected in the high-order bits.

- CL.7** - Inverter fault reset: always it varies from 0 → 1, an inverter reset is caused, with the presence of faults (except E24, E25, E26 e E27).
- CL.6** - no function / STOP detection. It is not necessary to activate the correspondent upper bit (refer to the description of parameter P310);
- CL.5** - To save P169/P170 in the EEPROM: 0 = to save, 1 = to not save;
- CL.4** - Local/Remote control: 0 = Local, 1 = Remote;
- CL.3** - Jog control: 0 = Inactive, 1 = Active;
- CL.2** - Direction of rotation: 0 = counter-clockwise, 1 = clockwise;
- CL.1** - General enabling: 0 = Disabled, 1 = Enabled;
- CL.0** - Start/Stop: 0 = Stop, 1 = Start.



**NOTE!**

The inverter will execute only the command indicated in the low-order bit, when the corresponding high-order bit has the value 1 (one). When the high-order bit has the value 0 (zero), the inverter will disregard the value of the corresponding low-order bit.



**NOTE!**

**CL.13:**

The function to save the changes of the parameters content in EEPROM occurs usually when the HMI is used. The EEPROM admits a limit number of writings (100 000). In the applications where the speed regulator is saturated, but the torque control is desired, you must change the current limitation value at P169/P170 (valid for P202=3 and 4). In this torque control condition, check if P160 (control type) = 1 (Regulator for torque control). When the network Master is writing in P169/P170 continuously, avoid to save the changes in the EEPROM, by setting:

**CL.13 = 1 and CL.5 = 1**

To control the functions of the Logical Control, you must set the respective inverter parameters with the Fieldbus option.

- a) Local/Remote selection - P220;
- b) Speed reference - P221 and/or P222;
- c) Direction of rotation - P223 and/or P226;
- d) General Enabling, Start/Stop - P224 and/or P227;
- e) Jog Selection - P225 and/or P228.

**2. Motor Speed Reference**

This variable is shown by using 13-bit resolution. Hence, the reference value for the motor synchronous speed will be equal to 8191 (1FFFh).

This value shall be used just as a base speed to calculate the desired speed (reference speed).

For example:

- 1) 4-poles motor , 60Hz, synchronous speed = 1800rpm and reference speed = 650 rpm  

$$\frac{1800 \text{ rpm}}{650 \text{ rpm}} = \frac{8191}{X} \quad X = 2958 = 0B8Eh$$

This value 0B8Eh shall be written in the second word which represents motor speed reference (according to item 8.12.5.2).

- 2) 6-poles motor, 60Hz, synchronous speed = 1200rpm and reference speed=1000rpm.  

$$\frac{1200 \text{ rpm}}{1000 \text{ rpm}} = \frac{8191}{X} \quad X = 4096 = 1AAAh$$

This value 1AAAh shall be written in the second word which represents motor speed reference (according to item 8.12.5.2).



**NOTE!**

It is possible to use values higher than 8191 (1FFFh) when it is desired to have values higher than the motor synchronous speed, since the maximum speed reference set for the drive is respected.

**3. Status of the Digital Outputs:**

It allows changing the status of the Digital Outputs that are programmed for the Fieldbus in the Parameters P275 to P280.

The word that defines the status of the digital outputs is formed by 16 bits, having the following construction:

- High-order bits:** define the output that shall be controlled when set to 1,
- bit.08** - 1= control of the output DO1;
- bit.09** - 1= control of the output DO2;

- bit.10** - 1= control of the output RL1;
- bit.11** - 1= control of the output RL2;
- bit.12** - 1= control of the output RL3;

**Low-order bits:** define the status desired for each output,

- bit.0** - output status DO1: 0 = output inactive, 1 = output active;
- bit.1** - output status DO2: ditto;
- bit.2** - output status RL1: ditto;
- bit.3** - output status RL2: ditto;
- bit.4** - output status RL3: ditto.

#### 4. Parameter Number to be Read:

Through this position you can read any inverter parameter.

You must enter the number corresponding to the desired parameter and its content will be displayed in Position 4 of the "Read Inverter Variables".

#### 5. Number of the Parameter to be changed:

(Parameter Content Changing)

This position works jointly with Pos. 6 below.

If no Parameter change is desired, you have to enter in this position the code **999**.

During the changing process you must:

- 1) Maintain in Position 5. The code 999;
- 2) Change the code 999 by the parameter number you want to change;
- 3) If no fault code (24 to 27) is displayed in the E.L., replace the code number by the code 999, to end the change.

The change can be checked through the HMI or by reading the parameter content.



#### NOTES!

- 1) The control change from scalar control to vector control will not be accepted if any of the parameters P409 to P413 is set to zero. This must be effected through the HMI.
- 2) Do not set P204=5, since P309=Inactive in the factory setting.
- 3) The desired content must be maintained by the master during 15.0 ms. Only after this time you can send a new value or write another parameter.

#### 6. Content of the Parameter to be changed, selected at Position 5.

(Number of the Parameter to be changed)

The format of the values set at this position must be as described in the Manual, but the value must be written without the decimal point, when the case.

When Parameters P409 to P413 are changed, small content differences can occur, when the value sent via Fieldbus is compared with the value read at Position 4 ("Parameter Content"), or with the value read via HMI. This is due the truncation (rounding off) during the reading process.

#### 8.12.5.3 Fault Indications

During the read/write process via Fieldbus the following variable indications in the Logical Status can occur:

##### Indications in the Logical Status variable:

**E24** - Parameter changing only permitted with disabled inverter.

- Parameter setting fault (see Item 4.2.3).

**E25** - Caused by:

- Read Parameter inexistent, or
- Write Parameter inexistent, or
- Write in P408 and P204

**E26** - The desired content value is out of permitted range.

**E27** - Caused by:

- a) The function selected in the Logical Control is not enabled for the Fieldbus, or
- b) The control of the Digital Output is not enabled for the Fieldbus, or
- c) The parameter write is read-only.

The fault indication described above will be removed from the Logical Status when the desired action is sent correctly. Except for E27 (case (b)), which reset is via write in the Logical Control.

**Example:** supposing that no digital output is programmed for Fieldbus, thus when in position 3. the word 11h is written, the inverter answer indicating E27 in E.L.. To remove this indication from E.L., you must:

- 1) write zero in Pos. 3.(since no DO is programmed for Fieldbus);
- 2) change the variable of the logical control, to remove from E.L. the E27 indication.

The removal of the fault indication from E.L. described above, can also be realized by writing the code 999 in Pos. 5. of the "Variables written in the Inverter". Except for the fault E27(in the cases (a) and (b)), which reset is realized only through the writing in the Logical Control, as above exemplified.



**NOTE!**

The faults E24, E25, E26 and E27 do not cause any change in the inverter operation status.

**HMI displays:**

**E29** - Fieldbus is inactive

- This display appears when the physical connection of the inverter to the Master is interrupted.
- You can program in Parameter P313 the action that the inverter shall execute when the fault E29 is detected.
- When the PROG key of the HMI is pressed, the E29 Fault indication is removed from the display.

**E30** - Fieldbus Board is inactive

This fault is displayed when:

- 1) P309 is programmed different than Inactive, without Fieldbus board in the XC140 connector of the CC9 control board; or
- 2) The Fieldbus board is inserted, but is defective; or
- 3) The Fieldbus board is inserted, but the standard programmed at P309 is not equal to the standard of the used board.

You can program in Parameter P313 which action the inverter will perform when E30 is detected.

When the PROG key of the HMI is pressed, the E30 Fault indication is removed from the display.

8.12.5.4 Addressing of the CFW-09 Variables in the Fieldbus Devices

The variables are arranged in the memory of the Fieldbus device, starting at the address 00h, both for writing and reading. The address differences are corrected by the protocol and by communication board.

The way the variables are arranged at each address in the memory of the Fieldbus depends on the equipment that is used as Master. For instance: in the PLC A the variables are arranged as High and Low, and in the PLC B the variables are arranged as Low and High.

## 8.13 SERIAL COMMUNICATION

### 8.13.1 Introduction

The basic objective of the serial communication is the physical connection of inverters in a configured equipment network, as shown below:

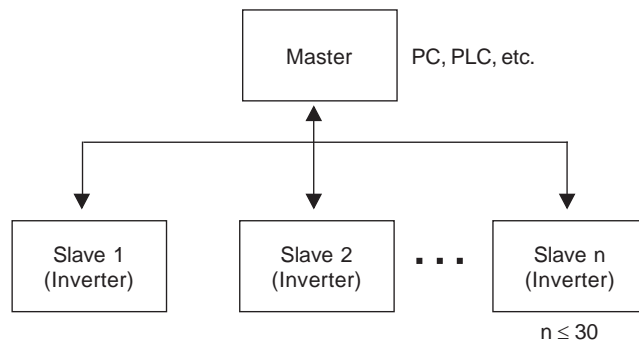

The inverters possess a control software for the transmission/reception of data through the serial interface, to facilitate the data reception sent by the master and the sending of data requested by the same.

The transfer rate is 9600 bits/s, following a exchange protocol, question/answer type by using ASCII characters.

The master is able to realize the following operations related to each inverter:

#### - IDENTIFICATION

- network number;
- inverter type;
- software version.

#### - CONTROL

- general enabling/disabling;
- enabling/disabling by ramp;
- direction of rotation;
- speed reference;
- local/remote
- JOG
- error RESET.

#### - STATUS RECOGNITION

- ready;
- Sub;
- run;
- local/remote;
- fault;
- JOG;
- direction of rotation;
- setting mode after Reset to Factory Setting
- setting mode after changing the scalar control mode to vector mode.
- self-tuning

- PARAMETERS READING

- CHANGE OF PARAMETERS

Typical examples of network use:

- PC (master) for parameterization of one or several inverters at the same time;
- SDCD monitoring inverter variables;
- PLC controlling the operation of an inverter in an industrial process.

### 8.13.2 Interfaces Description

The physical connection between the inverters and the network master is performed according to one of the standards below:

- a. RS-232 (point-to-point, up to 10m);
- b. RS-485 (multipoint, galvanic isolation, up to 1000m);

#### 8.13.2.1 RS-485

This interface allows the connection of up to 30 inverters to a master (PC, PLC, etc), attributing to each inverter an address (1 to 30) that must be set. In addition to these 30 addresses, there are two other addresses to perform special tasks:

- Address 0:** any network inverter is inquired, independently of its address. Only one inverter can be connected to the network (point-to-point) in order to prevent short-circuits in the line interface.
- Address 31:** a control can be transmitted to all inverters in the network simultaneously, without acceptance recognition.

#### List of addresses and corresponding ASCII characters

ADDRESS (P308)	ASCII		
	CHAR	DEC	HEX
0	@	64	40
1	A	65	41
2	B	66	42
3	C	67	43
4	D	68	44
5	E	69	45
6	F	70	46
7	G	71	47
8	H	72	48
9	I	73	49
10	J	74	4A
11	K	75	4B
12	L	76	4C
13	M	77	4D
14	N	78	4E
15	O	79	4F
16	P	80	50
17	Q	81	51
18	R	82	52
19	S	83	53
20	T	84	54
21	U	85	55
22	V	86	56
23	W	87	57
24	X	88	58
25	Y	89	59
26	Z	90	5A
27	]	91	5B
28	\	92	5C
29	[	93	5D
30	^	94	5E
31	-	95	5F

Table 8.20 - ASCII characters

**Other ASCII characters used in protocol.**

ASCII		
CODE	DEC	HEX
0	48	30
1	49	31
2	50	32
3	51	33
4	52	34
5	53	35
6	54	36
7	55	37
8	56	38
9	57	39
=	61	3D
STX	02	02
ETX	03	03
EOT	04	04
ENQ	05	05
ACK	06	06
NAK	21	15

**Table 8.21** - ASCII characters used in protocol.

The connection between the network participants is performed through a pair of wires. The signal levels are according to STANDARD EIA RS-485 with differential receivers and transmitters. Expansion boards of the types EBA.01, EBA.02 or EBB.01 (see Items 8.1.1 and 8.1.2).

When the master is fitted with only a serial interface - standard RS-232, you must apply a level conversion module from RS-232 to RS-485.

**8.13.2.2 RS-232**

In this case we have the connection of a master to an inverter (point-to-point). Data can be changed in a bi-directional way, but not simultaneous (HALF DUPLEX).

The logical levels meet STANDARD EIA RS-232C that determines the use of balanced signals.

In this case, one wire is used for transmission (TX), one for reception (RX) and one for return (0V) .This configuration is a three-wire economy model. (Refer to section 8.6)

**8.13.3 Protocol Definitions**

This items describe the protocol used for serial communication.

**8.13.3.1 Used Terms**

- Parameters: are those existing in the inverters whose visualization or alteration is possible through the HMI interface.
- Variables: are values that have specific inverter functions and that can be read and, in some cases, modified by the master.
- Basic variables: are those that can be accessed only through the serial interface.

SCHEMATIC DIAGRAM:

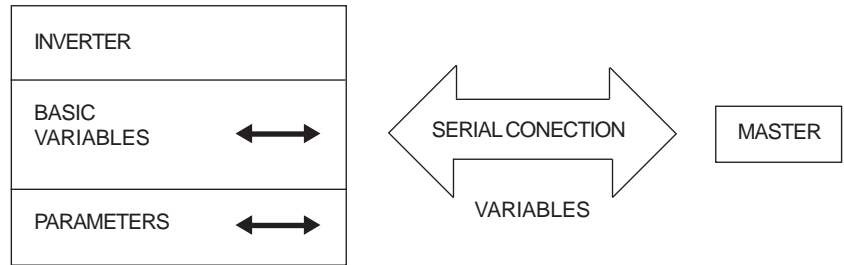

8.13.3.2 Parameters/Variables Resolution

During the parameter reading/changing the decimal point is disregarded in the values received with the telegram, excepting the Basic Variables V04 (Reference via Serial) and V08 Motor Speed) that are standardized in 13 bits (0 to 8191). For instance:

- ☑ Writing: if the purpose is to change the content of P100 to 10.0s, you must send 100 (disregarding the decimal point);
- ☑ Reading: If we read 1387 in P409, the value is 1.387( (the decimal point is disregarded);
- ☑ Writing: to change the content of V04 to 900 rpm, we must send:

$$V04 = 900 \times \frac{8191}{P208} = 4096$$

Supposing P208=1800 rpm

Reading: If we read 1242 in V08, this value is given by:

$$V08 = 1242 \times \frac{P208}{8191} = 273 \text{ rpm}$$

Supposing P208=1800 rpm

8.13.3.3 Characters Format

- ☑ 1 start bit;
- ☑ 8 information bits [they codify text characters and transmission characters, removed from the 7 bits code, according to ISO 646 and complemented for even parity (eighth bit)];
- ☑ 1 stop bit;

After the start bit, follows the less significant bit:

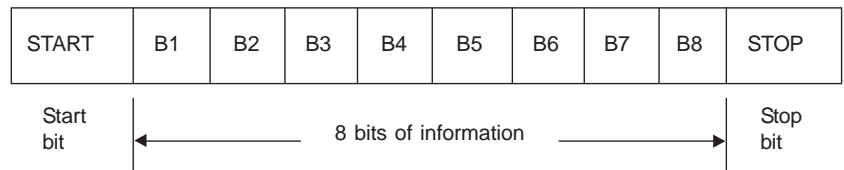

8.13.3.4 Protocol

The transmission protocol meets Standard ISO 1745 for data transmission in code. Only text characters sequences without header are used . The errors monitoring is made through transmission related to the parity of the individual 7 bit characters, according to ISO 646. The parity monitoring is made according to DIN 66219 (even parity). The master uses two types of messages:

- ☑ **READING TELEGRAM:** for inquiring of the inverter variable content;
- ☑ **WRITING TELEGRAM:** to change inverter variable content or to send controls to the inverters.



**NOTE!**

No transmission between two inverters is possible. The master has the bus access control.

**Reading Telegram**

This telegram allows the master receive from the inverter the content corresponding to the inquiry code. In the answer telegram the inverter transmits the data requested by the master.

1) Master:

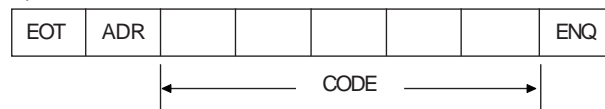

2) Inverter:

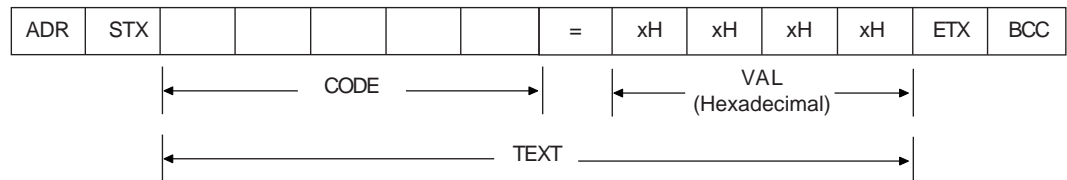

Format of the reading telegram:

- EOT:** control character of End of Transmission;
- ADR:** inverter address (ASCII @, A, B, C, to ) (ADdRes);
- CODE:** address of the 5-digit variable coded in ASCII;
- ENQ:** control character ENQuery (enquiry);

Format of the inverter answer telegram:

- ADR:** 1 character - inverter address;
- STX:** control character - Start of TeXt;
- TEXT:** consists in:
  - ☑ **CODE:** address of the variable;
  - ☑ “=”: separation of character;
  - ☑ **VAL:** 4 digits value (HEXADECIMAL);
- ETX:** control character - End of TeXt;
- BCC:** CheCksum Byte- EXCLUSIVE OR of all the bytes between STX (excluded) and ETX (included).



**NOTE!**

In some cases there can be an inverter answer with:

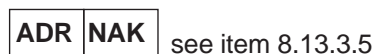

**Writing Telegram**

This telegram sends data to the inverters variables. The inverter answers by indicating if the data have been accepted or not.

1) Master:

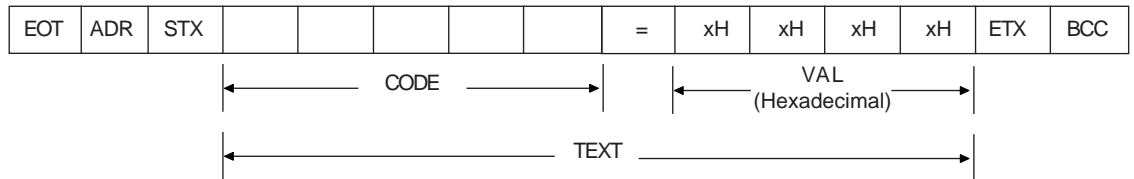

2) Inverter:

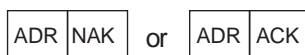

Format of the writing telegram:

**EOT:** control character of End Of Transmission;

**ADR:** inverter address;

**STX:** control character of Start of TeXt;

**TEXT:** consists in:

**CODE:** variable address;

“=”: separation character;

**VAL:** 4 HEXADECIMAL digit value ;

**ETX:** control character of End of TeXt;

**BCC:** Byte of CheCksum - EXCLUSIVE OR of all the bytes between STX (excluded) and ETX (included).

Format of the inverter answer telegram:

**Acceptance:**

**ADR:** inverter address;

**ACK:** ACKnowledge control character;

**No acceptance:**

**ADR:** inverter address;

**ACK:** ACKnowledge control character;

That means that the data were not accepted and the addressed variable continues with its old value.

8.13.3.5 Execution and Telegram Test

The inverters and the master test the telegram syntax.

The answers for the respective verified conditions are defined as follows:

**Reading telegram:**

no answer: with wrong telegram structure, control characters received incorrectly or wrong inverter address;

NAK: CODE corresponding to the variable does not exist or there is only writing variable;

TEXT: with valid telegrams;

**Writing telegram:**

- ☑ No answer: with wrong telegram structure, control characters received incorrectly or wrong inverter address;
- ☑ NAK: code corresponding to the variable does not exist, wrong BCC (checksum byte), only reading variable, VAL out of the allowed range for the respective variable, operation parameter out of the alteration mode;
- ☑ ACK: with valid telegrams;  
The master should maintain, between two variable transmissions to the same inverter, a waiting time that is compatible with the used inverter.

8.13.3.6 Telegram Sequence

In the inverters, the telegrams are processed in determined time intervals. Therefore, a pause larger than the sum of the times  $T_{proc} + T_{di} + T_{tx}$  cit should be guaranteed, between two telegrams addressed to the same inverter (see item 8.13.6).

8.13.3.7 Variable Code

The field designated with CODE contains the parameter address and the basic variables formed by 5 digits (ASCII characters) as follows:

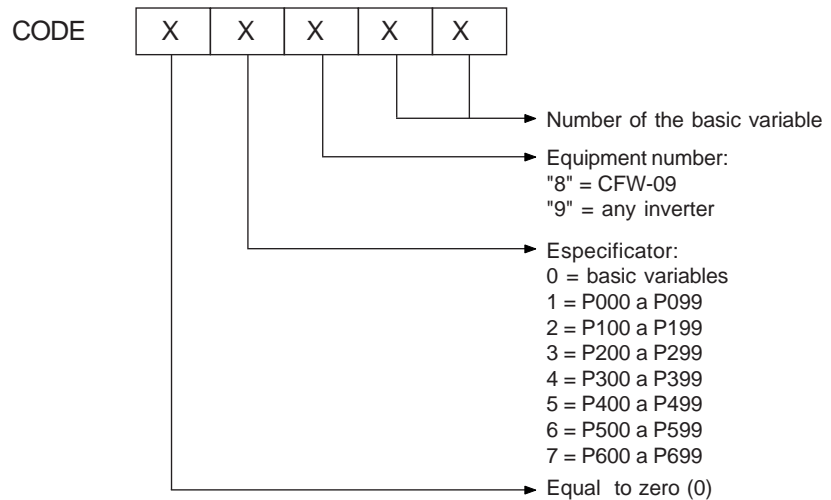

8.13.4 Telegram Examples

- ☑ Change of the min. speed (P133) to 600 rpm in the inverter 7.

1) Master:

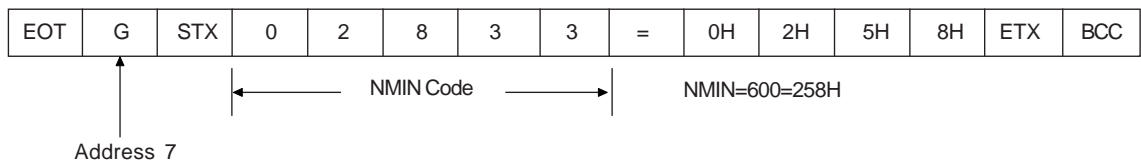

2) Inverter:

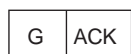

- Reading of output current from the inverter at address 10 (supposing that the same was at 7,8A at the moment of the enquiry).

1) Master:

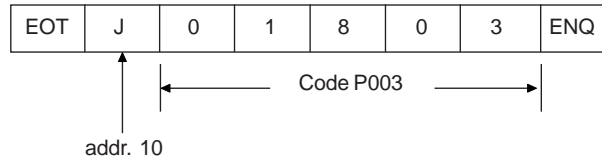

2) Inverter:

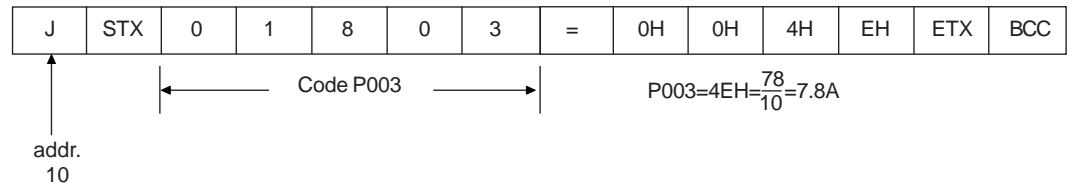

**NOTE!**

Values sent and received via serial interface are always integer values. It is necessary to know the parameter resolution in order to read the correct value. (Ex. Real Current Value = 7.8A ⇔ Received Value = 78)

8.13.5 Variables and Errors of the Serial Communication

8.13.5.1 Basic Variables

**V00 (code 00800):**

- Indication of the inverter type (reading variable)  
The reading of this variable allows the inverter type identification. For the CFW-09 this value is 8, as defined in 8.13.3.7.

**V02 (code 00802):**

- Indication of the inverter state (reading variable)
  - Logical status (byte-high)
  - Error code (byte-low)

Where:

- Logical status:

EL15	EL14	EL13	EL12	EL11	EL10	EL9	EL8
------	------	------	------	------	------	-----	-----

EL8:	0 = ramp enabling (run/stop) inactive 1 = ramp enabling	}	Inverter enabled EL8=EL9=1
EL9:	0 = general enabling inactive 1 = general enabling active		
EL10:	0 = reverse 1 = forward		
EL11:	0 = JOG inactive 1 = JOG active		
EL12:	0 = local 1 = remote		
EL13:	0 = without undervoltage 1 = with undervoltage		
EL14 :	not used		
EL15:	0 = without error 1 = with error		

Error Code: hexadecimal error number

Ex.: E00 → 00H  
E01 → 01H  
E10 → 0AH

**V03 (code 00803):**

Selection of the Logical Control

Writing variable, whose bits have the following meaning:

BYTE HIGH: desired action mask. The corresponding bit should be set to 1, so the action happens.

CL15	CL14	CL13	CL12	CL11	CL10	CL9	CL8
MSB				LSB			

- CL8: 1 = enabling ramp (Start/Stop)
- CL9: 1 = general enabling
- CL10: 1 = Forward/Reverse rotation
- CL11: 1 = JOG
- CL12: 1 = Local/Remote
- CL13: not used
- CL14: not used
- CL15: 1 = inverter "RESET"

BYTE LOW: logical level of the desired action.

CL7	CL6	CL5	CL4	CL3	CL2	CL1	CL0
MSB				LSB			

- CL0: 1 = enabling (Start)  
0 = disabling by ramp (Stop)
- CL1: 1 = enabling  
0 = general disabling (stops by inertia)
- CL2: 1 = forward  
0 = reverse
- CL3: 1 = JOG active  
0 = JOG inactive
- CL4: 1 = remote  
0 = local

- CL5: not used
- CL6: not used
- CL7: the transition in this bit from 0 to 1 causes the inverter “RESET”, when any error condition is present.



**NOTE!**

- Disabling via Dix has priority over these disabling;
- To enable the inverter by the serial it is necessary that CL0=CL1=1 and that the external disabling is inactive;
- If CL0=CL1=0 simultaneously, a general disabling occurs.

**V04 (code 00804):**

- Reference of Frequency given by Serial (reading/writing variable).  
It permits sending reference to the inverter provided P221=9 for LOC or P222=9 for REM. This variable has a 13-bit resolution (see Item 8.13.3.2).

**V06 (code 00806):**

- Status of the Operation Mode (read variable)

EL2 7	EL2 6	EL2 5	EL2 4	EL2 3	EL2 2	EL2 1	EL2 0
MSB				LSB			

- EL2.0:1 = in setting mode after Reset for Factory Setting/First Start-up.  
The inverter enter in this status as it is energized by the first time or when the factory setting for the parameters is loaded (P204=5 or 6). In this mode only the parameters P023, P295, P201, P296, P400, P401, P403, P402, P404 and P406 can be accessed. If any other parameter is accessed, the inverter displays E25. For more details, see Item 5.2 - Initial Start-up
- EL2.1:1 = in setting mode after changing the scalar control to vector control  
The inverter enters in this operation mode, when the control mode is changed from scalar control (P202=0, 1) or VVW (P202=5) to vector control (P202=3 or 4). In this mode only the parameters P023, P202, P295, P296, P400, P401, P403, P402, P404, P405, P406, P408, P409, P410, P411, P412 and P413 can be accessed. If any other parameter is accessed, the inverter displays E25. For more details, see Item 5.3.2 - Start-up Operation  
- Type of Control: Vector Sensorless or with Encoder.
- EL2.2:1 = Self-Tuning execution  
The inverter enters in this operation mode when P202=3 or 4 and P408 ≠ 0. For more details about Self-tuning, see Chapter 6 - Detailed Parameter Description, Parameter 408.
- EL2.3: 1 = in the setting mode after changing the control mode from V/Hz or Vector controls to VVW.  
The drive will enter in this operation mode when the control is changed from V/Hz (P202=0, 1 or 2) or Vector (P202=3 or 4) to VVW (P202=5). In this mode only parameters P023, P202, P295, P296, P400, P401, P403, P402, P404, P406, P407, P399, P408, P409 are accessible. In case of accessing any other parameter, the drive will trip with an error code E25. For additional information refer to item 5.3.3 - Start-up - Type of Control: VVW.
- EL2.4: not used
- EL2.5: not used
- EL2.6: not used
- EL2.7: not used

**V07 (code 00807):**

- Status of the Operation Mode (read/write variable)

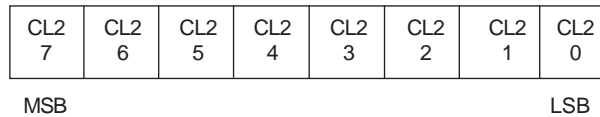

- CL2.0: 1 - It exit after reset from the setting mode to factory setting
- CL2.1: 1 - After changing it exit from scalar or VVW control to vector control
- CL2.2: 1 - aborts self-tuning
- CL2.3: 1 - exits the setting mode after changing the control mode from V/Hz or Vector to VVW
- CL2.4: 1 - not used
- CL2.5: 1 - not used
- CL2.6: 1 - not used
- CL2.7: 1 - not used

**V08 (code 00808):**

- Motor speed in 13 bits (read variable). It permits the reading of the motor speed with a 13-bit resolution (see Item 8.13.3.2).

8.13.5.2 Examples of Telegrams with basic variables

- Inverter enabling (provided P224=2 to LOC or P227=2 to REM)

1) Master:

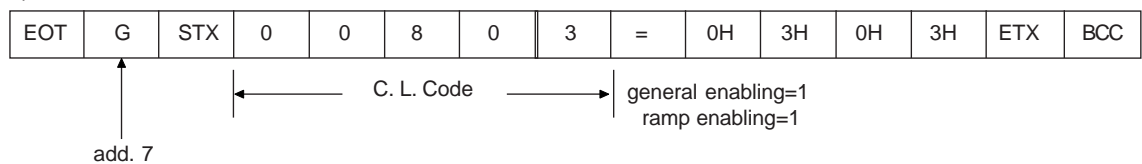

2) inverter:



- Change of the direction of rotation to reverse (provided P223=5 or 6 to LOC or P226=5 or 6 to REM)

1) Master:

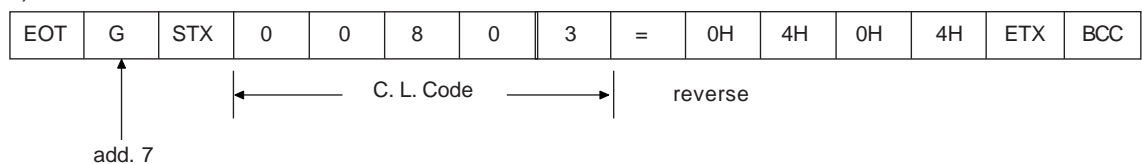

2) Inverter:



JOG enabling (provided P225=3 to LOC or P228=3 to REM)

1) Master:

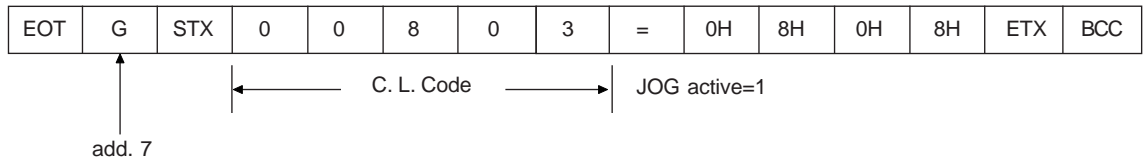

2) Inverter:

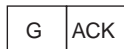

Fault Reset

1) Master:

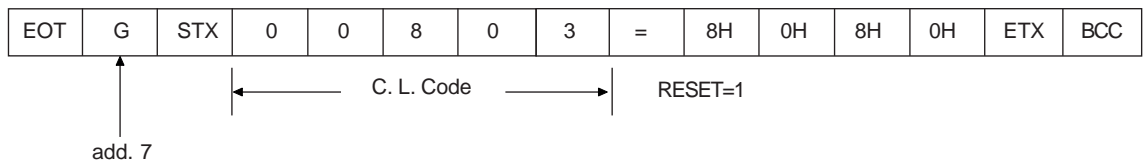

2) Inverter:

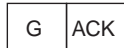

### 8.13.5.3 Parameters Related to the Serial Communication

Parameter number	Parameter description
P220	Local/Remote selection
P221	Local reference selection
P222	Remote reference selection
P223	Local forward/reverse selection
P224	Local Start/Stop selection
P225	Local JOG selection
P226	Remote forward/reverse selection
P227	Remote Start/Stop selection
P228	Remote JOG selection
P308	Inverter address on the Serial communication network (range values from 1 to 30)

**Table 8.22** - Parameters Related to the Serial Communication

For further information about the parameters above, see Chapter 6 - Detailed Parameter Description.

8.13.5.4 Errors Related to the Serial Communication

They act as follows:

- ☑ they do not disable the inverter;
- ☑ they do not disable defective relays;
- ☑ they are informed in the word the logical status.

☑ Fault Types

- E22: longitudinal parity fault;
- E24: parameterization fault (when some situation occurs as indicated in Table 4.2. (parameter incompatibility), - Chapter 4 - Keypad (HMI) Operation, or when there is a parameter change attempt that cannot be changed with running motor);
- E25: variable or parameter not existing;
- E26: expected value out of the allowed limits;
- E27: writing attempt in a read only variable or logical control disabled;
- E28: Serial communication is inactive. If the time programmed at P314 has elapsed without the inverter receiving a valid Modbus telegram, this is displayed by the HMI and the inverter adopts the action programmed at P313.



**NOTE!**

If a parity fault is detected during inverter data reception, the telegram will be ignored.

The same happens when syntax errors occur.

Ex.:

- Code values different from the numbers 0 to 9;
- Separation character different from “=”, etc.

8.13.6 Times for Read/Write of Telegrams

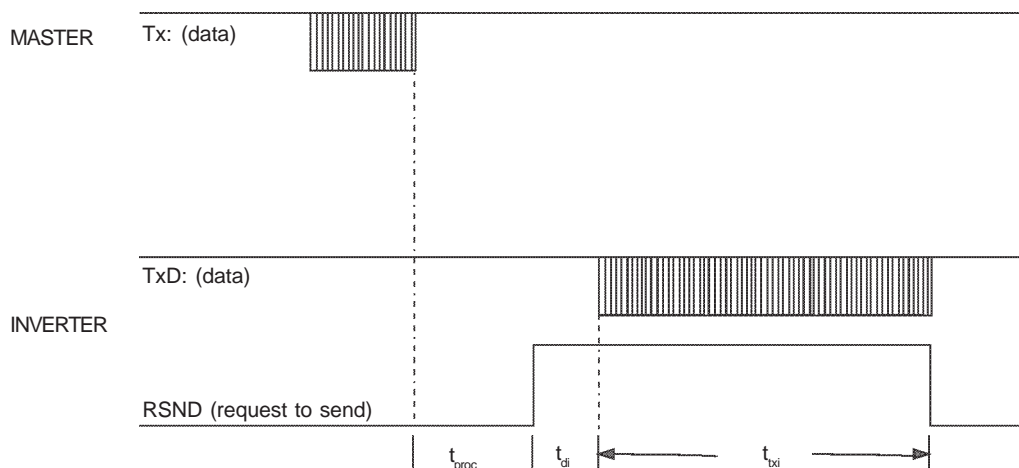

Time (ms)		Típical
$T_{proc}$		10
$T_{di}$		5
$T_{bxi}$	reading	15
	writing	3

8.13.7 Physical Connection  
of the RS-232 and RS-485  
Interface

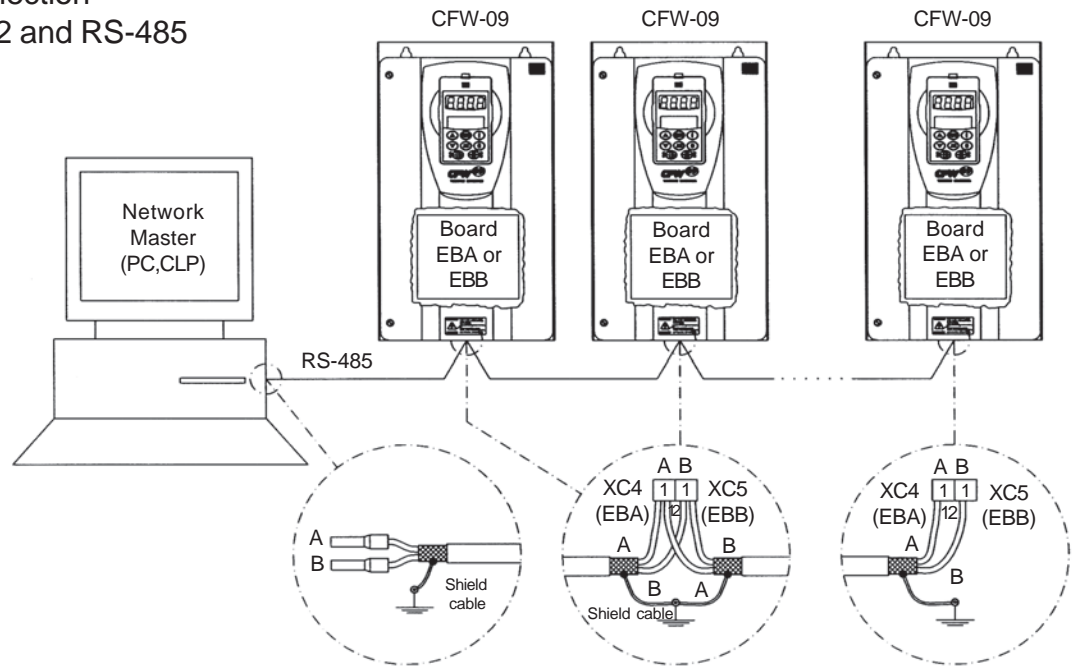

Figure 8.44 - CFW-09 network connection through RS-485 Serial Interface

**Notes:**

- ☑ LINE TERMINATION: include line termination ( $120\Omega$ ) at the ends. So set S3.1/S3.2 (EBA) and S7.1/S7.2 (EBB) to "ON" (see items 8.1.1 and 8.1.2);
- ☑ GROUNDING OF THE CABLE SHIELD: connect the shielding to the equipment frame (suitable grounding)
- ☑ RECOMMENDED CABLE: for balanced shielding.  
Ex: AFS series from KMP;
- ☑ The RS-485 wiring must be laid separately from the power and control cables in 110/220V.
- ☑ The reference signal for the RS-485 interface (SREF) shall be used when the network master is not connected to the system/installation ground. For instance, if the master is powered from an isolated power supply it is necessary to ground the power supply reference or carry this reference signal to the whole system.  
In general, it is possible to connect only signals A (-) and B (+), without connecting the signal SREF.

**RS-232 Serial Interface Module**

The RS-232 interface is available for the CFW09 through the module presented in item 8.6.

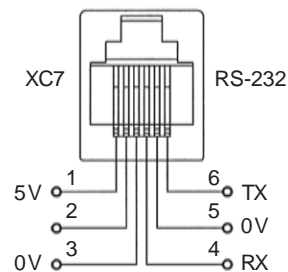

Figure 8.45 - Description of the XC7 (RJ12) connector

**Note:**

The RS-232 wiring must be laid separately from the power and control cables in 110/220V.



**NOTE!**

You cannot use simultaneously the RS-232 and the RS-485 interface.

8.14 MODBUS-RTU

8.14.1 Introduction in the Modbus-RTU Protocol

The Modbus protocol has been already developed 1979 firstly. Currently it is a wide diffused open protocol, used by several manufacturers in different equipment. The Modbus-RTU communication of the do CFW-09 has been developed by considering two documents:

1. MODBUS Protocol Reference Guide Rev. J, MODICON, June 1996.
2. MODBUS Application Protocol Specification, MODBUS.ORG, may 8<sup>th</sup> 2002.

In these documents are defined the format of the messages used by these elements that are part of the Modbus network, the services (or functions) that can be made available via network, and also how these elements exchange the data on the network.

8.14.1.1 Transmission Modes

Two transmission modes are defined in the protocol definition: ASCII and RTU. The transmission modes define the form how the message bytes are transmitted. It is not permitted to use the two transmission modes on the same network.

In the RTU mode each transmitted word has one start bit, eight data bits, 1 parity bit (optional) and 1 stop bit (2 stop bits, if no parity bit is used). Thus the bit sequence for the transmission of 1 byte is as follows:

Start	B0	B1	B2	B3	B4	B5	B6	B7	Parity or Stop	Stop
-------	----	----	----	----	----	----	----	----	----------------	------

In the RTU mode each transmitted word has 1 start bit, eight data bits, 1 parity bit (optional) and 1 stop bit (2 stop bits, if parity bit is not used). Thus the bit sequence for the transmission is as follows:

8.14.1.2 Message Structure in RTU Mode

The Modbus RTU network operates in Master-Slave system and it can consist of up to 247 slaves but only one Master. The master always initiates the communication with a question to a slave and the slave answers the question. Both messages (question and answer) have the same structure: Address, Function Code, and CRC. Depending on what is being requested, only the data field has variable length.

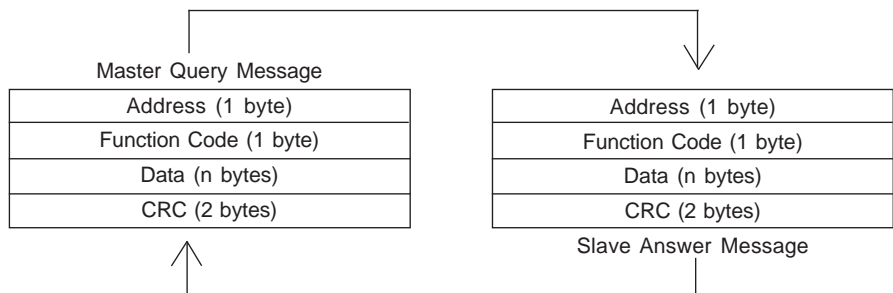

Figure 8.46 - Message Structure

**Address:**

The master initiates the communication by sending one byte with the address of the slave to which the message is addressed. The slave with the right slave address initiates the message with its own address. The master can also send a message destined to address 0 (zero), which means that the message is destined to all network slaves (broadcast). In this case no slave will answer to the master.

**Function Code:**

This field contains an only byte, where the master specifies the type of service or the function requested to the slave (read, write, etc.). According to the protocol, each function is used to access a specific data type. In the CFW-09 all data are available as holding type registers (referenced from the address 40000 or '4x'). Besides these registers, the inverter status (enabled/disabled, with error/no error and the command for the inverter (Start/Stop, Run CW/CCW, etc.) can be also accessed through the coils read/write functions or the internal bits (referenced from the address 00000 or '0x' on).

**Data Field:**

This field has variable length. The format and the content of this field depend on the used function and transmitted values. This field and the respective functions are described in item 8.14.3.

**CRC:**

The last part of the message is the field for checking the transmission errors. The used method is the CRC-16 (Cycling Redundancy Check). This field is formed by two bytes, where the least significant byte (CRC-) is transmitted first and only then the most significant byte is transmitted (CRC+). CRC calculation is started by loading a 16-bit variable (mentioned from now on as CRC variable) with FFFFh value. Then following steps are executed with the following routine:

1. The first message byte (only the data bits - the start bit, parity bit and stop bit are not used) is submitted to the XOR logic (OR exclusive) with the 8 least significant bits of the CRC variable, returning the result to the CRC variable,
2. Then the CRC variable is displaced one position to the right, in the direction of the least significant bit and the position of the most significant bit is filled out with zero 0 (zero).
3. After this displacement, the flag bit (bit that has been displaced out the CRC variable) is analyzed, by considering the following:
  - If the bit value is 0 (zero), no change is made.
  - If the bit value is 1, the CRC variable content is submitted to XOR logic with a constant A001h value and the value is returned to the CRC variable.
4. Repeat steps 2 and 3 until the eight displacements have been realized.
5. Repeat the steps 1 to 4, by using the next byte message until the whole message have been processed. The end content of the CRC variable is the value of the CRC field that is transmitted at the end of the message. The least significant part is transmitted first (CRC-), only then the most significant part (CRC+) is transmitted.

**Times between Messages:**

In the RTU mode there is no specific character that indicates the beginning or the end of a message. Thus the only indication for the beginning or the end of a new message is the data transmission absence in the network by 3.5 times the time required for transmission of one data word (11 bits). Thus if a message is initiated after elapsing of the minimum time required without transmission, the network elements assume that the received character represents the beginning of a new message. In similar mode, after this time has elapsed, the network elements will assume that the message has been ended.

If during the transmission of a message, the time between the bytes is longer than this minimum required time, the message will be considered invalid, since the inverter will discard the already received bytes and will mount a new message with the bytes that are being transmitted.

The table below shows the time for three different communication rates.

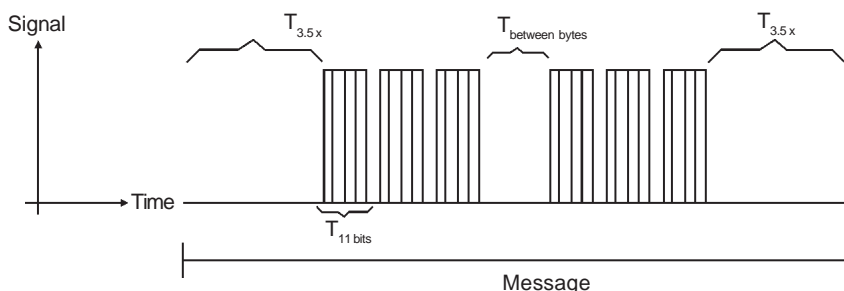

**Figure 8.47** - Times required during the communication of a message

Communication Rate	$T_{11 \text{ bits}}$	$T_{3.5x}$
9600 kbits/sec	1.146 ms	4.010 ms
19200 kbits/sec	573 $\mu$ s	2.005 ms
38400 kbits/sec	285 $\mu$ s	1.003 ms

- $T_{11 \text{ bits}}$  = Time to transmit one word of the message.
- $T_{\text{entre bytes}}$  = Time between bytes (can not be longer than  $T_{3.5x}$ ).
- $T_{3.5x}$  = Minimum interval to indicate the begin and the end of the message ( $3.5 \times T_{11 \text{ bits}}$ ).

**8.14.2 Operation of the CFW-09 in the Modbus-RTU Network**

The CFW-09 frequency inverters operate as slaves of the Modbus-RTU network. The communication initiates with the master of the Modbus-RTU network requesting a service for a network address. When the inverter is configured to the corresponding address, it processes the question and answers to the master as requested.

**8.14.2.1 Interface RS-232 and RS-485 description**

The CFW-09 frequency inverters use a serial interface for the communication with the Modbus-RTU network. There are two ways to perform the connection between the network master and the CFW-09:

**RS-232:**

- The interface is used for the point-to-point connection (between a single slave and the master).
- Max. distance: 10 meters.
- Signal levels according to EIA STANDARD RS-232C.
- Three wires: transmission (TX), reception (RX) and return (0V).
- The serial interface RS-232 must be used.

**RS-485:**

- This interface is used for multipoint connection (several slaves and the master).
  - Max. distance: 1000 meters (use of shielded cables).
  - Signal levels according to EIA STANDARD RS-485.
  - You must use the EBA or EBB expansion board that has interface for the RS-485 communication.
- Note: for connection, see 8.13.7.

8.14.2.2 Inverter Configuration in the Modbus-RTU Network

To ensure a correct communication in the network, you must configure the inverter address in the network as well as the transfer rate and the existing parity type, besides the correct physical connection.

**Inverter Address in the Network:**

- The inverter address is defined through the parameter P308.
- If the serial communication type (P312) has been configured to Modbus-RTU, you may select the addresses from 1 to 247.
- Each slave shall have a different address.
- The master does not have address.
- The slave address must be known, even when connection is made point-to-point.

**Transmission Rate and Parity:**

- Both configurations are defined by parameter P312.
- Baud rates: 9600, 19200 or 38400 kbits/sec.
- Parity: None, odd parity, even parity.
- All slaves and even the network master must use the same baud rate and parity.

8.14.2.3 Access to the Inverter Data

All parameters and available basic variables for the CFW-09 can be accessed through the network:

- Parameters: are those set in the inverter and that can be displayed and changed through the HMI (Human-Machine Interface) (see item 1 Parameters).
- Basic Variables: are the internal inverter variables that can be accessed only through serial interface. For instance, through these basic variables you can change the speed reference, read the inverter status, enable or disable the inverter, etc. (see item 8.13.5.1 - Basic Variables).
- Register: nomenclature used to represent both parameters and basic variables during data transfer.
- Internal Bits: bits that are accessed only through the serial interface and that are used for inverter status controlling and monitoring. Item 8.13.3.2 defines the resolution of the parameters and variables transmitted via serial interface.

**Available Functions and Response Times:**

In the Modbus RTU protocol specification is defined the functions used for accessing different types of registers described in the specification. In the CFW-09 both parameters and basic variables are defined as being holding type registers (referenced as 4x). In addition to these registers, it is also possible to access the internal controlling and monitoring bits directly (referenced as 0x).

Following services (or functions) are available in the CFW-09 frequency inverter for accessing these registers:

**Read Coils**

Description: reading of internal register blocks or coils.

Function code: 01.

Broadcast: not supported

Response time: 5 to 10 ms.

**Read Holding Registers**

Description: reading of register blocks of holding type.

Function code: 03.

Broadcast: not supported

Response time: 5 to 10 ms.

**Write Single Coil**

Description: writing in a single internal bit or coil.

Function code: 05.

Broadcast: supported.

Response time: 5 to 10 ms.

**Write Single Register**

Description: writing in a single register of holding type.

Function code: 06.

Broadcast: supported

Response time: 5 to 10 ms.

**Write Multiple Coils**

Description: writing in internal bit blocks or coils.

Function code: 15.

Broadcast: supported

Response time: 5 to 10 ms.

**Write Multiple Registers**

Description: writing in register blocks of holding type.

Function code: 16.

Broadcast: supported

Response time: 10 to 20 ms for each written register.

**Read Device Identification**

Description: Identification of the inverter model.

Function code: 43.

Broadcast: not supported.

Response time: 5 a 10 ms.

Note: The Modbus RTU network slaves are addressed from 1 to 247. Master uses address 0 to send messages that are common to all slaves (broadcast).

**Data Addressing and Offset:**

The CFW-09 data addressing is realized with an offset equal to zero that means that the address number is equal to the register number. The parameters are available from address 0 (zero) on, whilst the basic variables are available from address 5000 on. In same way, the status bits are made available from

address 0 (zero) on and the control bits are made available from address 100 on.

Table below shows the addressing of bits, parameters and basic variables:

Parameters		
Parameter Number	Endereço Modbus	
	Decimal	Hexadecimal
P000	0	00h
P001	1	01h
⋮	⋮	⋮
P100	100	64h
⋮	⋮	⋮

Basic Variables		
Number of the Basic Variable	Modbus Address	
	Decimal	Hexadecimal
V00	5000	1388h
V01	5001	1389h
⋮	⋮	⋮
V08	5008	1390h

Status Bits		
Bit Number	Modbus Address	
	Decimal	Hexadecimal
Bit 0	00	00h
Bit 1	01	01h
⋮	⋮	⋮
Bit 7	07	07h

Commands Bits		
Bit Number	Modbus Address	
	Decimal	Hexadecimal
Bit 100	100	64h
Bit 101	101	65h
⋮	⋮	⋮
Bit 107	107	6Bh

Note: All registers (parameters and basic variables) are considered as *holding* type registers, referenced from 40000 or 4x, whilst the bits are referenced from 0000 or 0x.

The status bits have the same functions of the bits 8 to 15 of the logic status (basic variable 2). These bits are available only for read, thus any attempt to write command returns error status to the master.

Status Bits	
Bit Number	Function
Bit 0	0 = Ramp enabling inactive 1 = Ramp enabling active
Bit 1	0 = General enabling inactive 1 = General enabling active
Bit 2	0 = Counter-clockwise direction of rotation 1 = Clockwise direction of rotation
Bit 3	0 = JOG inactive 1 = JOG active
Bit 4	0 = Local Mode 1 = Remote Mode
Bit 5	0 = No undervoltage 1 = With undervoltage
Bit 6	Not used
Bit 7	0 = No fault 1 = With fault

The command bits are available to read and write and they have the same function of the logic command bits 0 to 7 (basic variable 3), however no requiring the use of the mask. The basic variable 3 write influences the status of these bits.

Command Bits	
Bit Number	Function
Bit 100	0 = Ramp disable (Stop) 1 = Ramp enable (Start)
Bit 101	0 = General disable 1 = General enable.
Bit 102	0 = Counter-clockwise direction of rotation 1 = Clockwise direction of rotation
Bit 103	0 = JOG disable 1 = JOG enable
Bit 104	0 = Goes to local mode 1 = Goes to remote mode
Bit 105	Not used
Bit 106	Not used
Bit 107	0 = It does not reset inverter 1 = It resets inverter

### 8.14.3 Detailed Function Description

This section describes in details the functions that are available in the CFW-09 for the Modbus RTU communication. Please note the following during the message preparation:

- Values are always transmitted as hexadecimal values.
- The address of one data, the data number and the value of the registers are always represented through 16 bits. Thus these fields are transmitted by using two bytes (high and low). To access the bits, and the form to represent one bit depend on the used function.
- The messages, both for enquiry and response, cannot be longer than 128 bytes.
- The resolution of each parameter or basic variable is as described in item 8.13.3.2.

8.14.3.1 Function 01 - Read Coils

It reads the content of an internal group of bits that must compulsorily in a numerical sequence. This function has the following structure for the read and response messages (the values are always hexadecimal, and each field represents one byte):

Query (Master)		Response (Slave)	
Slave address		Slave address	
Function		Function	
Initial bit address (byte high)		Byte Count Field (number of data bytes)	
Initial bit address (byte low)		Byte 1	
Number of bits (byte high)		Byte 2	
Number of bits (byte low)		Byte 3	
CRC-		etc to	
CRC+		CRC-	
		CRC+	

Each response bit is placed at a position of the data bytes sent by the slave. The first byte, from the bits 0 to 7, receives the first 8 bits from the initial address indicated by the master. The other bytes (if the number of the read bits is higher than 8) remain in the same sequence. If the number of the read bits is not a multiple of 8, the remaining bits of the last byte should be filled out with 0 (zero).

- Example: reading of the status bits for general enable (bit 1) and direction of rotation (bit 2) of then CFW-09 at the address 1:

Query (Master)		Response (Slave)	
Field	Value	Field	Value
Slave address	01h	Slave address	01h
Function	01h	Function	01h
Initial bit address (byte high)	00h	Byte Count	01h
Initial bit address (byte low)	01h	Status of the bits 1 and 2	02h
Number of bits (byte high)	00h	CRC-	D0h
Number of bits (byte low)	02h	CRC+	49h
CRC-	ECh		
CRC+	0Bh		

As the number of read bits in the example is smaller than 8, the slave required only 1 byte for the response. The value of the byte was 02h, That as binary value will have the form 0000 0010. As the number of read bits is equal to 2, only the two less significant bits, that have the value 0 = general disable and 1 = direction of rotation are of interest, are of interest. The other bits, as they did not be requested, are filled out with 0 (zero).

8.14.3.2 Function 03 - Read Holding Register

It reads the content of a group of registers that must be compulsorily in a numerical sequence. This function has following structure for the read and response messages (the values are always hexadecimal values, and each field represents one byte):

Query (Master)	Response (Slave)
Slave address	Slave address
Function	Function
Initial register address (byte high)	Byte Count Field
Initial register address (byte low)	Data 1 (high)
Number of registers (byte high)	Data 1 (low)
Number of registers (byte low)	Data 2 (high)
CRC-	Data 2 (low)
CRC+	etc to
	CRC-
	CRC+

Example: Read of the value proportional to the frequency value (P002) and motor current (P003) of the CFW-09 at address 1:

Query (Master)		Response (Slave)	
Field	Value	Field	Value
Slave address	01h	Slave address	01h
Function	03h	Function	03h
Initial register (byte high)	00h	Byte Count	04h
Initial register (byte low)	02h	P002 (high)	03h
Number of registers (byte high)	00h	P002 (low)	84h
Number of registers (byte low)	02h	P003 (high)	00h
CRC-	65h	P003 (low)	35h
CRC+	CBh	CRC-	7Ah
		CRC+	49h

Each register is always formed by two bytes (high e low). For the example, we have P002 = 0384h, that in decimal number is equal to 900. As these parameters do not have a decimal place indication, the real read value is 900 rpm. In the same way we will have a current value P003 = 0035h, that is equal to a 53 decimal. As the current has a decimal resolution, the read value is 5.3 A.

### 8.14.3.3 Function 05 - Write Single Coil

This function is used to write a value to a single bit. The bit value is represented by using two bytes, where FF00h represents the bit that is equal to 1, and 0000h represents the bit that is equal to 0 (zero). It has the following structure (the values are always hexadecimal, and each field represents one byte):

Query (Master)	Response (Slave)
Slave address	Slave address
Function	Function
Bit address (byte high)	Bit address (byte high)
Bit address (byte low)	Bit address (byte low)
Bit value (byte high)	Bit value (byte high)
Bit value (byte low)	Bit value (byte low)
CRC-	CRC-
CRC+	CRC+

- ☑ Example: to drive a ramp enable command (bit 100 = 1) of a CFW-09 at the address 1:

Query (Master)		Response (Slave)	
Field	Value	Field	Value
Slave address	01h	Slave address	01h
Function	05h	Function	05h
Bit number (high)	00h	Bit number (high)	00h
Bit number (low)	64h	Bit number (low)	64h
Bit value (high)	FFh	Bit value (high)	FFh
Bit value (low)	00h	Bit value (low)	00h
CRC-	CDh	CRC-	CDh
CRC+	E5h	CRC+	E5h

For this function, the slave response is an identical copy of the query sent by the master.

#### 8.14.3.4 Function 06 - Write Single Register

This function is used to write a value to a single register. This function has following structure (values are always hexadecimal values, and each field represents one byte):

Query (Master)	Response (Slave)
Slave address	Slave address
Function	Function
Register address (byte high)	Register address (byte high)
Register address (byte low)	Register address (byte low)
Value for the register (byte high)	Value for the register (byte high)
Value for the register (byte low)	Value for the register (byte low)
CRC-	CRC-
CRC+	CRC+

Example: write of the speed reference (basic variable 4) equal to 900 rpm, of a CFW-09 at address 1. Please remember, that the value for the basic variable 4 depends on the used motor type and that the value 8191 is equal to the rated motor speed. In this case, we suppose that the used motor has a rated speed of 1800 rpm, thus the value to be written into the basic variable 4 for a speed of 900 rpm is the halve of 8191, i.e., 4096 (1000h).

Query (Master)		Response (Slave)	
Field	Value	Field	Value
Slave address	01h	Slave address	01h
Function	06h	Function	06h
Register (high)	13h	Register (high)	13h
Register (low)	8Ch	Register (low)	8Ch
Value (high)	10h	Value (high)	10h
Value (low)	00h	Value (low)	00h
CRC-	41h	CRC-	41h
CRC+	65h	CRC+	65h

For this function, the slave response will be again a copy identical to the request made by the master. As already informed above, the basic variables are addressed from 5000, thus the basic variable 4 will be addressed at 5004 (138Ch).

8.14.3.5 Function 15 - Write Multiple Coils

This function allows writing values for a bit group that must be in numerical sequence. This function can be also used to write a single bit (the values are always hexadecimal, and each field represents one byte).

Query (Master)		Response (Slave)	
Slave address		Slave address	
Function		Function	
Initial bit address (byte high)		Initial bit address (byte high)	
Initial bit address (byte low)		Initial bit address (byte low)	
Number of bits (byte high)		Number of bits (byte high)	
Number of bits (byte low)		Number of bits (byte low)	
Byte Count Field (number of data bytes)		CRC-	
Byte 1		CRC+	
Byte 2		-	
Byte 3		-	
etc to		-	
CRC-		-	
CRC+		-	

The value of each bit that is being sent is placed at a position of the data bytes sent by the master. The first byte, in the bits 0 to 7, receives the 8 first bits by starting from the initial address indicated by the master. The other bytes (if the number of inscribed bits is higher than 8) remain in sequence. If the number of inscribed bits is not a multiple of 8, the remaining bits of the last byte should be filled in with 0 (zero).

- Example: command writing for general enabling (bit 100 = 1), general enabling (bit 101 = 1) and CWW-direction of rotation (bit 102 = 0), for a CFW-09 at address 1:

Query (Master)		Response (Slave)	
Field	Value	Field	Value
Slave address	01h	Slave address	01h
Function	0Fh	Function	0Fh
Initial bit (byte high)	00h	Initial bit (byte high)	00h
Initial bit (byte low)	64h	Initial bit (byte low)	64h
Number of bits (byte high)	00h	Number of bits (byte high)	00h
Number of bits (byte low)	03h	Number of bits (byte low)	03h
Byte Count	01h	CRC-	54h
Bits Value	03h	CRC+	15h
CRC-	BEh	-	-
CRC+	9Eh	-	-

As only three bits are written, the master needed only one byte to transmit the data. The transmitted values are in the three less significant bits of the byte that contains the value for the bits. The other bits of this byte remained with the value 0 (zero).

8.14.3.6 Function 16 - Write Multiple Registers

This function allows writing values to a register group that must be in numerical sequence. This function can also be used to write a single register (the values are always hexadecimal values and each field represents one byte).

Query (Master)	Response (Slave)
Slave address	Slave address
Function	Function
Initial register address (byte high)	Initial register address (byte high)
Initial register address (byte low)	Initial register address (byte low)
Number of registers (byte high)	Number of registers (byte high)
Number of registers (byte low)	Number of registers (byte low)
Byte Count Field (number of data bytes)	CRC-
Data 1 (high)	CRC+
Data 1 (low)	-
Data 2 (high)	-
Data 2 (low)	-
etc to	-
CRC-	-
CRC+	-

- ☑ Example: writing of the acceleration time P100 = 1.0s and deceleration time P101 = 2.0s, of a CFW-09 at the address 20:

Query (Master)		Response (Slave)	
Field	Value	Field	Value
Slave address	14h	Slave address	14h
Function	10h	Function	10h
Initial register (byte high)	00h	Initial register (byte high)	00h
Initial register (byte low)	64h	Initial register (byte low)	64h
Number of registers (byte high)	00h	Number of registers (byte high)	00h
Number of registers (byte low)	02h	Number of registers (byte low)	02h
Byte Count	04h	CRC-	02h
P100 (high)	00h	CRC+	D2h
P100 (low)	0Ah	-	-
P101 (high)	00h	-	-
P101 (low)	14h	-	-
CRC-	91h	-	-
CRC+	75h	-	-

As the two parameters have a resolution of a decimal place for writing of 1.0 and 2.0 seconds, thus the values 10 (000Ah) and 20 (0014h) should be transmitted.

8.14.3.7 Function 43 - Read Device Identification

Auxiliary function that permits reading of the manufacturer, model and version of the product firmware. It has following structure.

Query (Master)	Response (Slave)
Slave address	Slave address
Function	Function
MEI Type	MEI Type
Read Code	Conformity Level
Object Number	More Follows
CRC-	Next Object
CRC+	Number of Objects
-	Object Code*
-	Object length*
-	Object Value*
-	CRC-
-	CRC+

\*The fields are repeated according to the number of objects.

This function permits reading of three information categories:

Basic, Regular and Extended and each category are formed by a group of objects. Each object is formed by a sequence of ASCII characters For the CFW-09 are only available basic information formed by three objects:

- Object 00 - VendorName: always 'WEG'.
- Object 01 - ProductCode: formed by the product code (CFW-09), plus the rated inverter current.

Object 02 - MajorMinorRevision: it indicates the inverter firmware version,  in 'VX.XX' format.

The read code indicates which information categories are being read and if the objects are accessed individually or by sequence.

In the example, the inverter supports 01 (basic information in sequence), and 04 (individual access to the objects).

The other fields for the CFW-09 have fixed values.

Example: read o basic information in sequence, starting from object 00, of a CFW-09 at address 1:

Query (Master)		Response (Slave)	
Field	Value	Field	Value
Slave address	01h	Slave address	01h
Function	2Bh	Function	2Bh
MEI Type	0Eh	MEI Type	0Eh
Read Code	01h	Read Code	01h
Object Number	00h	Conformity Level	51h
CRC-	70h	More Follows	00h
CRC+	77h	Next Object	00h
-	-	Number of Objects	03h
-	-	Object Code	00h
-	-	Object Length	03h
-	-	Object Value	'WEG'
-	-	Object Code	01h
-	-	Object Length	0Eh
-	-	Object Value	'CFW-09 7.0A'
-	-	Object Code	02h
-	-	Object Length	05h
-	-	Object Value	'V2.09'
-	-	CRC-	B8h
-	-	CRC+	39h

In the example the Object Value has not been represented as hexadecimal value, but with corresponding ASCII characters. For instance, for the object 00, the 'WEG' value has been transmitted as being three ASCII characters, that as hexadecimal have the values 57h (W), 45h (E) and 47h (G).

8.14.4 Communication Errors

Errors can occur during the message transmission on network, or in the content of the received messages. Depending on the error type, inverter may answer or not to the master:

When the master sends a message to an inverter configured at determined network address, the inverter will not response if:

- Error in the parity bit.
- Error the CRC.
- Time out between transmitted bytes (3.5 times the time required for the transmission of a 11-bit word).

In the case of a successful reception of the message, the inverter can detect problems and send a error message to the master indicating the problem that has been verified:

- Invalid function (error code = 1): the requested function has not been implemented for the inverter.
- Invalid data address (error code = 2): the data address (register or bit) does not exist.
- Data value invalid (error code = 3): this error occurs in the following conditions:
  - Value is out of permitted range.
  - Writing in data that cannot be changed (only read register, or register that does not allow changing with enabled inverter or bits of logic status).
  - Writing in function of the logic command that has not been enabled via serial interface.

8.14.4.1 Error Messages

When any error occurs in the message content (not during the data transfer), the slave must return a message indicating the error type that occurred. The errors that may occur in the CFW-08 during the message processing are errors relating to invalid function (code 01), invalid data address (code 02) and invalid data value (code 03).

The messages sent by the slave have following structure:

Response (Slave)
Slave address
Function Code
(with most significant bit to 1)
Error code
CRC-
CRC+

- Master requests from the slave at address 1 to write parameter 89 (inexistent parameter):

Query (Master)		Response (Slave)	
Field	Value	Field	Value
Slave address	01h	Slave address	01h
Function	06h	Function	86h
Register (high)	00h	Error Code	02h
Register (low)	59h	CRC-	C3h
Value (high)	00h	CRC+	A1h
Value (low)	00h		
CRC-	59h		
CRC+	D9h		

8.15 KIT KME (for Extractable Mounting)

The kit KME enables the mounting of CFW-09 inverter in the sizes 8, 8E, 9, 10 and 10E (models 361A to 600A/380-480V, 107A to 472A/500-690V and 100A to 428A/660-690V) in the panel in an extractable form. The inverter is mounted in the panel like a sliding drawer, thus making easier the assembling and maintenance works. When requesting this kit, please specify the following:

Item	Description	Notes
417102521	KIT KME - CFW-09 M10/L=1000	Size 10 - 450A to 600A/380-480V and Size 10E - 247A to 472A/500-690V and 255A to 428A/660-690V Panel width= 1000mm (39.37in)
417102520	KIT KME - CFW-09 M9/L=1000	Size 9 - 312A to 361A/380-480V Panel width= 1000mm (39.37in)
417102522	KIT KME - CFW-09 M9/L=800	Size 9 - 312A to 361A/380-480V Panel width= 800mm (31.50in)
417102540	KIT KME - CFW-09 M8/L=600	Size 8 - 211A to 240A/380-480V and Size 8E - 107A to 211A/500-690V and 100A to 179A/660-690V Panel width= 600mm (23.62in)
417102541	KIT KME - CFW-09 M8/L=800	Size 8 - 211A to 240A/380-480V Size 8E - 107A to 211A/500-690V and 100A to 179A/660-690V Panel width= 800mm (31.50in)

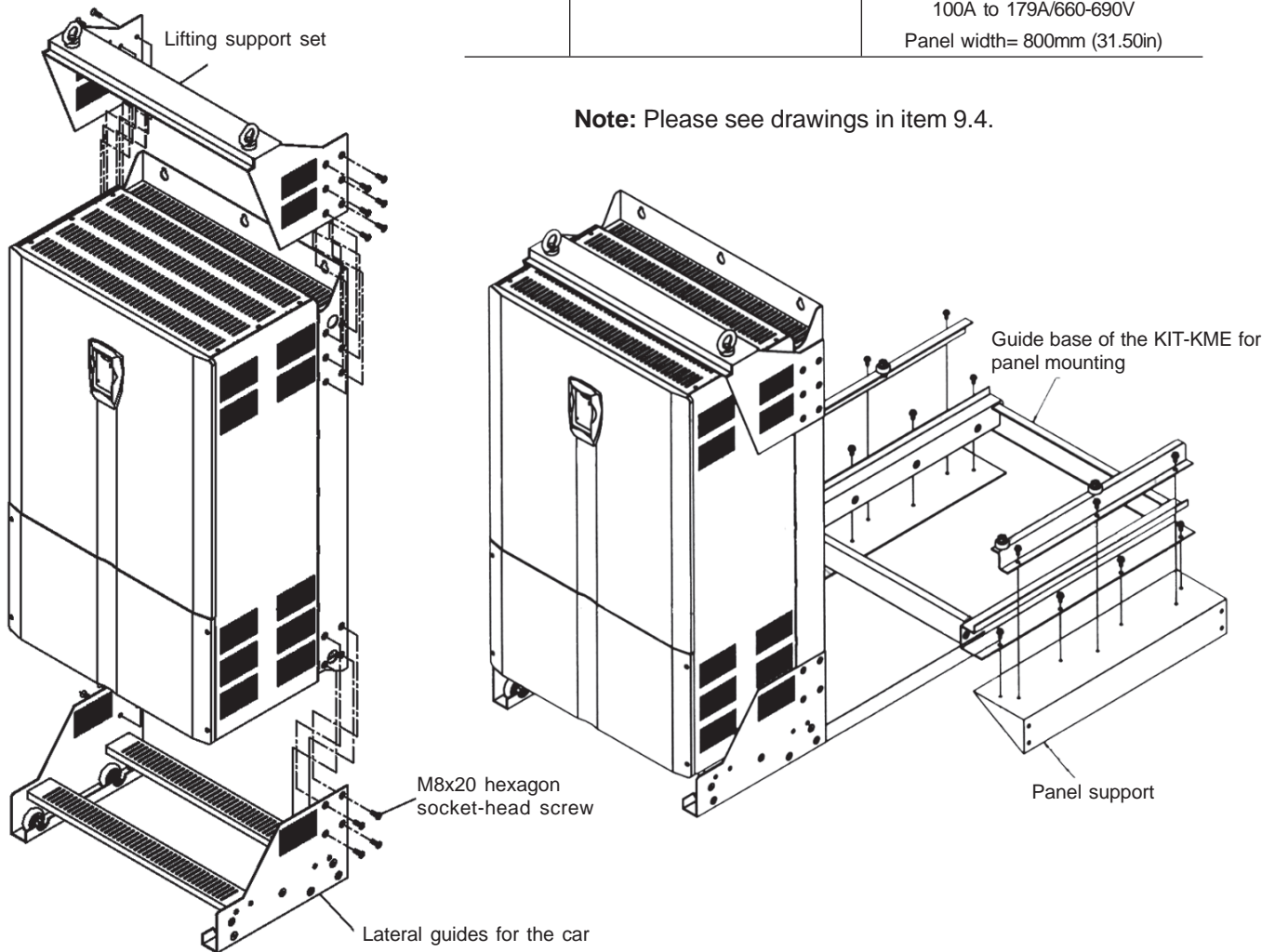

**Note:** Please see drawings in item 9.4.

Figure 8.48 - Mounting of the KIT-KME on the inverter

8.16 CFW-09 SHARK  
NEMA 4X

In applications that need a Drive with a higher protection enclosure, the CFW-09 SHARK NEMA 4X is indicated. The NEMA 4X provides protection against dust, dirt and splashing or hose-directed water.

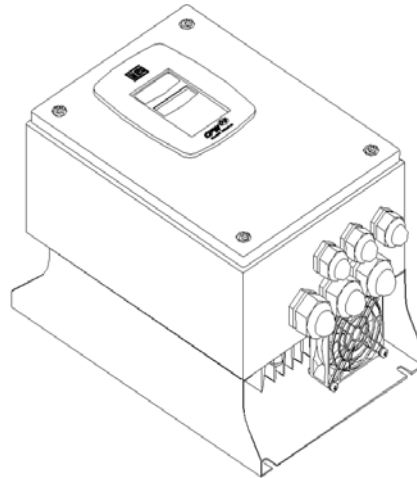

Figure 8.49 - CFW-09 Shark Nema 4X

The SHARK NEMA 4X is the CFW-09 standard with a stainless steel enclosure. The models are:

CFW 09 0006 T 2223	Size 1 *
CFW 09 0007 T 2223	
CFW 09 0010 T 2223	
CFW 09 0016 T 2223	Size 2 *
CFW 09 0003 T 3848	Size 1 *
CFW 09 0004 T 3848	
CFW 09 0005 T 3848	
CFW 09 0009 T 3848	Size 2 *
CFW 09 0013 T 3848	
CFW 09 0016 T 3848	

\* The Shark Drive dimensions are distinct from the standard CFW-09 Drive, so, the Sizes 1 and 2 from the Shark Drive are different from the Sizes 1 and 2 of the standard CFW-09.

8.16.1 Enclosure  
Specifications

NEMA Type 4X indoors;  
NEMA Type 12 indoors;  
IP 56;  
Other specifications are same to the standard CFW-09 and are explained along this manual.

8.16.2 Mechanical  
Installation

The Drive comes covered by a plastic film. Remove this sheet before starting the installation.  
Install the drive in an environment that does not exceed Type 4 / 4X / 12 limitations.  
Install the Drive on a flat surface, in the vertical position;  
External dimensions and mounting holes are according to figures 8.50 and 8.51.

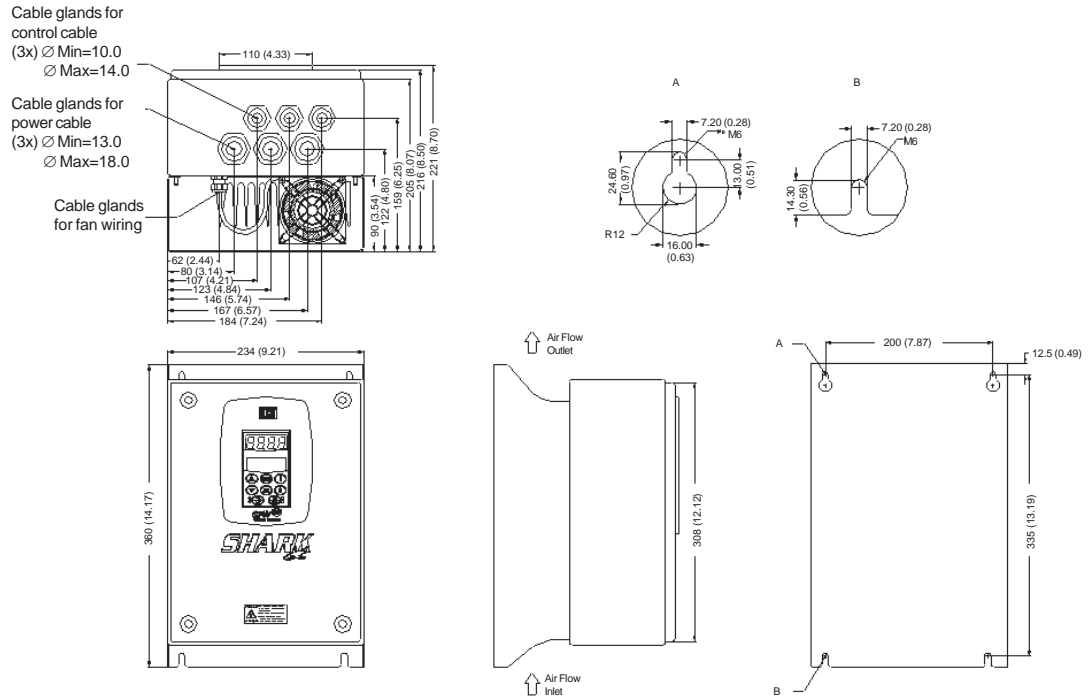

Figure 8.50 - Mechanical data – Size 1, Dimensions mm (in)

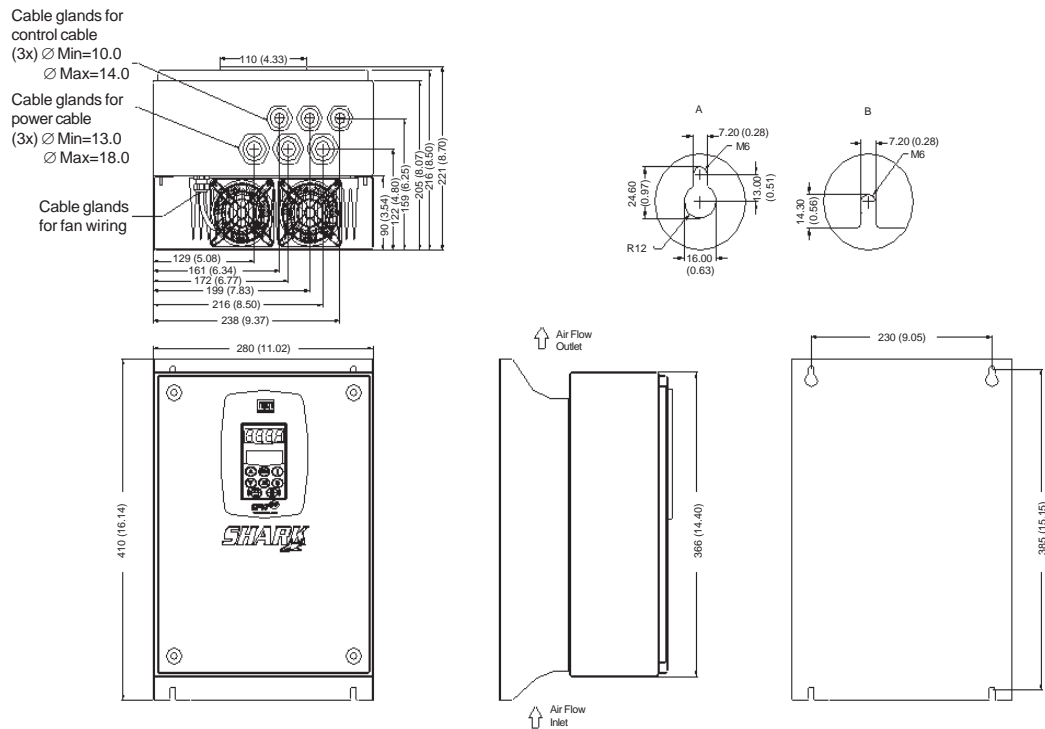

Figure 8.51 - Mechanical data – Size 2, Dimensions mm (in)

8.16.3 Electrical Installation

The electrical installation is the same as CFW-09 standard. Refer to Chapter 3, item 3.2 to make a correct electrical installation.



**NOTE!**

To assure the NEMA 4X total protection, it is necessary to use correct cables. It is recommended to use armored multi-core cables. For example, one tetra-polar armored cable for Power supply (R,S,T) plus grounding, and another tetra-polar armored cable for output (motor) connection.

The wire sizing and fuses are presented in table 3.5, Chapter 3.



*Figure 8.52 - Tetra-polar armored cable*

The control and power wiring access to the Drive is through the cable glands. All the cable glands come with a gasket inside. To make the electrical installation it is necessary to remove the gasket from the cable gland and then pass the armored multi-core cable in the cable gland.

After doing the electrical connection and arrange the cables properly, tight the cable glands to assure that the cable is very strongly fastened. The recommended torque is 2N.m (0.2kgf.m).

The control wiring has to be made by armored multi-core cables too. It is necessary to use this type of cables to guarantee total closing after cable glands tightening. Check the maximum and minimum diameter of the cables supported by the Cable Glands in figures 8.50 and 8.51.

8.16.4 Closing the Drive

To guarantee NEMA 4X degree of protection, it is very important to close correctly the Drive after doing the electrical installation. Please follow these instructions:

After the electrical installation is completed and the cable glands tightened, close the frontal cover (certify that the flat cable that interconnects the HMI to the control card is correctly connected) by tightening each screw a little at a time, until total tightening.

The gaskets provide the protection of the electronic parts of the SHARK drive. Any problem with them can cause problems with the protection degree. Opening and closing the drive many times reduces the gaskets lifetime. It is recommended to do this no more than 20 times. If problems are detected on the gaskets, we recommend changing the failed gasket immediately.

Certify that the door gasket is on its correct position at the moment you will close the Drive.

Certify that the door screw gaskets are perfect on the moment you are ready to close the drive.

All these recommendations are very important to become a successful installation.



**NOTE!**

Do not remove the gaskets inside the cable glands, which were not used. They are necessary to guarantee NEMA 4X protection.

8.16.5 How to Specify

To specify a NEMA 4X Drive, it is necessary to include the term “N4” in the field “Enclosure Degree of Protection” according to the CFW-09 specification in Chapter 2, item 2.4 (CFW-09 Identification). Remember that the NEMA 4X line is only up to 10HP.

8.17 CFW-09 SUPPLIED BY THE DC LINK – LINE HD

- ☑ The CFW-09HD inverter line, supplied by DC link, has the same installation, mechanical, programming and performance characteristics as the Standard CFW-09 line;
- ☑ Up to size 5, an HD inverter is required to make the supply through the DC link. In this case is sufficient to supply a standard inverter through the DC link with an external pre-charge circuit.
- ☑ The models of size 6 and larger are fitted with an internal pre-charge circuit and have internal changes;
- ☑ For more detail, refer please to the Addendum of the CFW-09 Frequency Inverter Manual of the CFW-09HD line – supplied by DC Link. (See [www.weg.com.br](http://www.weg.com.br)).

8.18 CFW-09 RB REGENERATIVE CONVERTER

There are two problems associated to a conventional drive with diode bridge at the input: harmonics injection to the network and braking of loads with high inertia, or that un at high speeds and require short braking times. The harmonic injection to the network happens with any type of load. The braking problems appear with loads such as sugar centrifuges, dynamometers, cranes and winders. The CFW-09 converter with RB option (Regenerative Braking) is WEG solution for these problems. Figure 8.53. Shows the main components of a drive with CFW-09 RB.

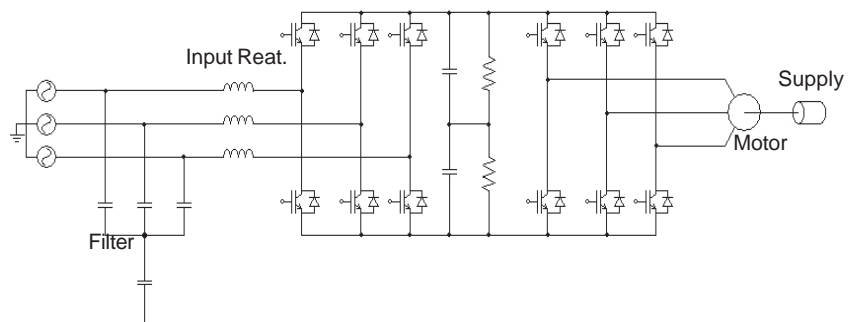
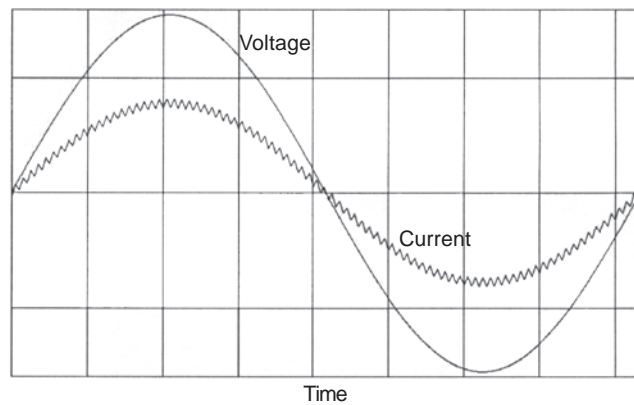

Figure 8.53 - Simplified diagram of a driving with CFW-09 RB

As shown in the Figure 8.53, CFW-09RB unit is fitted with a capacitor bank and a IGBT's bridge.

Externally is mounted a network reactance and a capacitive filter.

By switching the IGBT's bridge, the energy can be transferred in a controlled way from the network to the capacitor bank. One can say that by means of the switching process, the CFW-09RB emulates a resistive load. There is also a capacitive filter to prevent the bridge switching interferes in other network loads. To complete this drive, the use of a CFW-09HD is required that drives the motor and its load. This drive is shown in Figure 8.53 by the second IGBT's bridge. Figure 8.54 a) shows wave shapes of the CFW-09 RB input voltage and current, when the motor at the drive output is operating normally.



**Figure 8.54 a)** - Functioning during operation as motor

Figure 8.54 b) shows the wave shapes of the CFW-09 RB input voltage and current, when the motor at the drive output is submitted to a braking process.

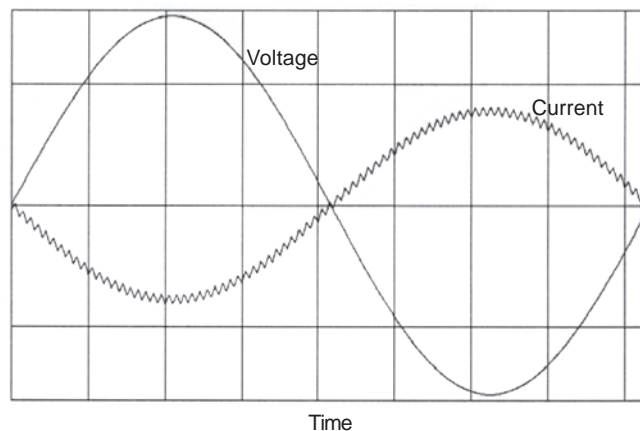

**Figure 8.54 b)** - Functioning during the braking process

For more details, refer to the CFW-09 RB Regenerative Converter Manual. (See [www.weg.com.br](http://www.weg.com.br)).

8.19 PLC BOARD

The PLC1 and PLC2 boards allow the CFW-09 drive to have PLC function, speed reference and positioning modules. This board is optional and is incorporated internally into the CFW-09.

Both boards cannot be used simultaneously with the EBA, EBB or EBC boards.

The PLC1 cannot be used with fieldbus boards.

The PLC2 can have fieldbus board mounted.

**Technical Characteristics**

- ☑ Positioning with trapezoidal and “S” profile (absolute and relative);
- ☑ Homing (machine zero search);
- ☑ Programming in *Ladder language through the WLP Software*, Timers, Contactors, Coils and Contacts;
- ☑ RS-232 with Modbus RTU protocol;
- ☑ Real-time clock;
- ☑ Availability of 100 parameters that may be set by the user through the Software or via HMI;
- ☑ CAN interface with CANopen and DeviceNet protocols;
- ☑ Master/Slave function (ElectronicGear Box);
- ☑ It has own 32 bits CPU with flash memory.

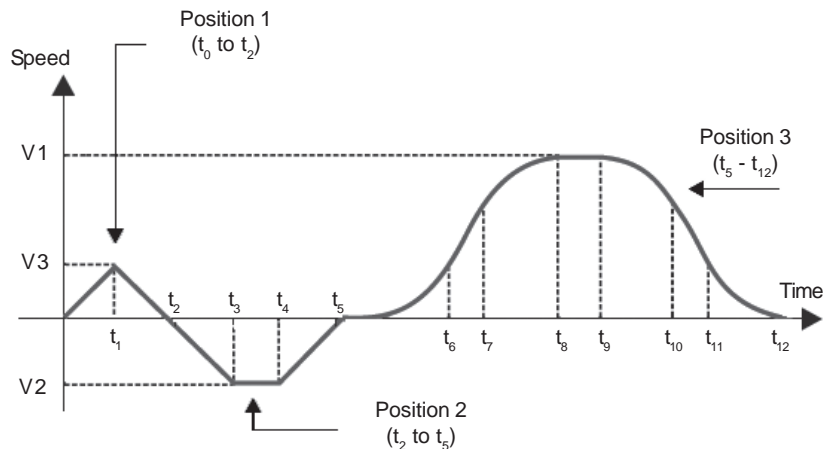

Figure 8.55 - Trajectory example by using the PLC board

Input/Output	Technical Specification			
	PLC 1		PLC 2	
	Quantities	Description	Quantities	Description
Digital inputs	9	24Vdc bipolar	9	24 Vdc bipolar
Relay outputs	3	250 Vac/3 A ou 250 Vdc/3 A	3	250Vac/3 A or 250Vdc/3 A
Transistorized outputs	3	24 Vdc/500 mA	3	24 Vdc/500 mA
Encoder power supply	1	15 V	2	5 to 24 V
Analog output	-	-	2	12 bits (-10 V to +10 V or (0 to 20) mA)
Analog input	-	-	1	14 bits (-10 V to +10 V or (-20 to 20) mA)
Motor PTC isolated input	-	-	1	Motor PTC isolated input

Note: For more details, see please the PLC Board Manual. The manual download may be effected from the site: [www.weg.com.br](http://www.weg.com.br).

## TECHNICAL SPECIFICATIONS

This Chapter describes the technical specifications (electrical and mechanical) of the CFW-09 inverter series.

### 9.1 POWER DATA

#### 9.1.1 Power Supply Specifications

**Operating voltage range:**

- ☑ 220-230V, 380-480V and 660-690V models: -15% to +10%.
- ☑ 500-600V models up to 32 A: -15% of rated input voltage up to 690V.
- ☑ 500-600V models higher or equal to 44A:
  - for power supplies = 500V, 525V or 575V:  $\pm 15\%$ ;
  - for power supply = 550V: -15% to +20%;
  - for power supply = 600V: -15% to +10%.
- ☑ 500-690V models:
  - for power supplies = 500V, 525V or 575V:  $\pm 15\%$ ;
  - for power supply = 550V: -15% to +20%;
  - for power supply = 600V: -15% to +10%;
  - for power supplies = 660V or 690V: -15% to +10% (\*1).

\*1 - When a line voltage higher than 600V (rated value) supplies the 500-690V models, it is necessary to derate the output current as stated in item 9.1.5.



**NOTE!**

- ☑ For models that have rated voltage selection jumper (as described in item 3.2.3) the rated input voltage is defined by its position.
- ☑ In all models, P296 parameter shall be set to the rated input voltage.
- ☑ When input voltage is lower than motor rated voltage the motor power will be reduced.

**Other AC input specifications:**

- ☑ Frequency: 50/60Hz ( $\pm 2$  Hz).
- ☑ Phase Unbalance  $\leq 3\%$  of rated phase to phase input voltage.
- ☑ Overvoltage Category III (EN 61010/UL 508C).
- ☑ Transient voltages according to Category III.

**Minimum line impedance:**

- ☑ 1% voltage drop for models with rated current up to 130A/220-230V, up to 142A/380-480V and up to 32A/500-600V.
- ☑ 2% voltage drop for 380-480V models with rated current 180A and above.
- ☑ 500-600V models with current higher or equal to 44A/500-600V and all 500-690V and 660-690V models do not require minimum line impedance, because they have an internal DC link inductance.
- ☑ See item 8.7.1 guidelines.

**Power-up:**

- ☑ 10 ON/OFF cycles per hour maximum.

9.1.2 220-230V Power Supply

Model: Current / Voltage	6/ 220-230	7/ 220-230	10/ 220-230	13/ 220-230	16/ 220-230	24/ 220-230	28/ 220-230
Load <sup>(1)</sup>	CT/VT	CT/VT	CT/VT	CT/VT	CT/VT	CT/VT	CT/VT
Power (kVA) <sup>(2)</sup>	2.3	2.7	3.8	5	6.1	9.1	10.7
Rated Output Current (A) <sup>(3)</sup>	6	7	10	13	16	24	28
Maximum Output Current (A) <sup>(4)</sup>	9	10,5	15	19.5	24	36	42
Rated Input Current (A) <sup>(7)</sup>	7.2/15 <sup>(6)</sup>	8.4/18 <sup>(6)</sup>	12/25 <sup>(6)</sup>	15.6	19.2	28.8	33.6
Rated Switching Frequency (kHz)	5	5	5	5	5	5	5
Maximum Motor (HP)/(W) <sup>(5)</sup>	1.5/1.1	2/1.5	3/2.2	4/3.0	5/3.7	7.5/5.5	10/7.5
Watts Loss (W) <sup>(8)</sup>	69	80	114	149	183	274	320
Frame Size	1	1	1	1	2	2	2

Model: Current / Voltage	45/ 220-230	54/ 220-230		70/ 220-230		86/ 220-230		105/ 220-230		130/ 220-230	
Load <sup>(1)</sup>	CT/VT	CT	VT	CT	VT	CT	VT	CT	VT	CT	VT
Power (kVA) <sup>(2)</sup>	18	21	27	28	34	34	42	42	52	52	60
Rated Output Current (A) <sup>(3)</sup>	45	54	68	70	86	86	105	105	130	130	150
Maximum Output Current (A) <sup>(4)</sup>	68	81		105		129		158		195	
Rated Input Current (A) <sup>(7)</sup>	54	65	82	84	103	103	126	126	156	156	180
Rated Switching Frequency (kHz)	5	5	2.5	5	2.5	5	2.5	5	2.5	5	2.5
Maximum Motor (HP)/(kW) <sup>(5)</sup>	15/11	20/ 15	25/ 18.5	25/ 18.5	30/ 22	30/ 22	40/ 30	40/ 30	50/ 37	50/ 37	60/ 45
Watts Loss (kW) <sup>(8)</sup>	0.5	0.6	0.8	0.8	1.0	1.0	1.2	1.2	1.5	1.5	1.7
Frame Size	3	4		5		5		6		6	

9.1.3 380-480V Power Supply

Model: Current / Voltage	3,6/ 380-480	4/ 380-480	5,5/ 380-480	9/ 380-480	13/ 380-480	16/ 380-480	24/ 380-480
Load <sup>(1)</sup>	CT/VT	CT/VT	CT/VT	CT/VT	CT/VT	CT/VT	CT/VT
Power (kVA) <sup>(2)</sup>	2.7	3.0	4.2	6.9	9.9	12.2	18.3
Rated Output Current (A) <sup>(3)</sup>	3.6	4	5.5	9	13	16	24
Maximum Output Current (A) <sup>(4)</sup>	5.4	6	8.3	13.5	19.5	24	36
Rated Input Current (A) <sup>(7)</sup>	4.3	4.8	6.6	10.8	15.6	19.2	28.8
Rated Switching Frequency (kHz)	5	5	5	5	5	5	5
Maximum Motor (HP)/(kW) <sup>(5)</sup>	1.5/1.1	2/1.5	3/2.2	5/3.7	7.5/5.5	10/7.5	15/11
Watts Loss (W) <sup>(8)</sup>	60	66	92	152	218	268	403
Frame Size	1	1	1	1	2	2	2

**Note:** CT = Constant Torque  
VT = Variable Torque

 Factory Default

## CHAPTER 9 - TECHNICAL SPECIFICATIONS

Model: Current / Voltage	30/ 380-480		38/ 380-480		45/ 380-480		60/ 380-480		70/ 380-480		86/ 380-480		105/ 380-480	
	CT	VT	CT	VT	CT	VT	CT	VT	CT	VT	CT	VT	CT	VT
Load <sup>(1)</sup>														
Power (kVA) <sup>(2)</sup>	24	29	30	36	36	43	48	56	56	68	68	84	84	100
Rated Output Current (A) <sup>(3)</sup>	30	36	38	45	45	54	60	70	70	86	86	105	105	130
Maximum Output Current (A) <sup>(4)</sup>	45		57		68		90		105		129		158	
Rated Input Current (A) <sup>(7)</sup>	36	43.2	45.6	54	54	64.8	72	84	84	103	103	126	126	156
Rated Switching Frequency (kHz)	5	2.5	5	2.5	5	2.5	5	2.5	5	2.5	5	2.5	5	2.5
Maximum Motor (HP)/(kW) <sup>(5)</sup>	20/ 15	25/ 18.5	25/ 18.5	30/ 22	30/ 22	40/ 30	40/ 30	50/ 37	50/ 37	60/ 45	60/ 45	75/ 55	75/ 55	100/ 75
Watts Loss (kW) <sup>(8)</sup>	0.50	0.60	0.70	0.80	0.80	0.90	1.00	1.20	1.20	1.50	1.50	1.80	1.80	2.20
Frame Size	3		4		4		5		5		6		6	

Model: Current / Voltage	142/ 380-480		180/ 380-480	211/ 380-480	240/ 380-480	312/ 380-480	361/ 380-480	450/ 380-480	515/ 380-480	600/ 380-480
	CT	VT	CT/VT	CT/VT	CT/VT	CT/VT	CT/VT	CT/VT	CT/VT	CT/VT
Load <sup>(1)</sup>										
Power (kVA) <sup>(2)</sup>	113	138	143	161	191	238	287	358	392.5	478
Rated Output Current (A) <sup>(3)</sup>	142	174	180	211	240	312	361	450	515	600
Maximum Output Current (A) <sup>(4)</sup>	213		270	317	360	468	542	675	773	900
Rated Input Current (A) <sup>(7)</sup>	170	209	191	223	254	331	383	477	546	636
Rated Switching Frequency (kHz)	5	2.5	2.5	2.5	2.5	2.5	2.5	2.5	2.5	2.5
Maximum Motor (HP)/(kW) <sup>(5)</sup>	100/ 75	125/ 90	150/ 110	175/ 130.5	200/ 150	250/ 186.5	300/ 220	350/ 250	450/ 335.7	500/ 375
Watts Loss (kW) <sup>(8)</sup>	2.4	2.9	3	3.5	4	5.2	6	7.6	8.5	10
Frame Size	7		8	8	8	9	9	10	10	10

### 9.1.4 500-600V Power Supply

Model: Current / Voltage	2.9/ 500-600		4.2/ 500-600		7/ 500-600		10/ 500-600		12/ 500-600		14/ 500-600
	CT	VT	CT	VT	CT	VT	CT	VT	CT	VT	CT/VT
Load <sup>(1)</sup>											
Power (kVA) <sup>(2)</sup>	2.9	4.2	4.2	7	7	10	10	12	12	13.9	13.9
Rated Output Current (A) <sup>(3)</sup>	2.9	4.2	4.2	7	7	10	10	12	12	14	14
Maximum Output Current (A) <sup>(4)</sup>	4.4	4.6	6.3	7.7	10.5	11	15	15	18	18	21
Rated Input Current (A) <sup>(7)</sup>	3.6	5.2	5.2	8.8	8.8	12.5	12.5	15	15	17.5	17.5
Rated Switching Frequency (kHz)	5	5	5	5	5	5	5	5	5	5	5
Maximum Motor (HP)/(kW) <sup>(5)</sup>	2/1.5	3/2.2	3/2.2	5/3.7	5/3.7	7.5/5.5	7.5/5.5	10/7.5	10/7.5	12.5/9.2	12.5/9.2
Watts Loss (W) <sup>(8)</sup>	70	100	100	160	160	230	230	280	280	330	330
Frame Size	2		2		2		2		2		2

**Note:** CT = Constant Torque  
VT = Variable Torque

 Factory Default

Model: Current / Voltage	22/ 500-600		27/ 500-600		32/ 500-600
	CT	VT	CT	VT	CT/VT
Load <sup>(1)</sup>	CT	VT	CT	VT	CT/VT
Power (kVA) <sup>(2)</sup>	21.9	26.9	26.9	31.9	31.9
Rated Output Current (A) <sup>(3)</sup>	22	27	27	32	32
Maximum Output Current (A) <sup>(4)</sup>	33	33	40.5	40.5	48
Rated Input Current (A) <sup>(7)</sup>	27.5	33.8	33.8	40	40
Rated Switching Frequency (kHz)	5	5	5	5	5
Maximum Motor (HP)/(kW) <sup>(5)</sup>	20/15	25/18.5	25/18.5	30/22	30/22
Watts Loss (W) <sup>(8)</sup>	500	620	620	750	750
Frame Size	4		4		4

Model: Current / Voltage	44/ 500-600		53/ 500-600		63/ 500-600		79/ 500-600	
	CT	VT	CT	VT	CT	VT	CT	VT
Load <sup>(1)</sup>	CT	VT	CT	VT	CT	VT	CT	VT
Power (kVA) <sup>(2)</sup>	43.8	52.8	52.8	62.7	62.7	78.7	78.7	98.6
Rated Output Current (A) <sup>(3)</sup>	44	53	53	63	63	79	79	99
Maximum Output Current (A) <sup>(4)</sup>	66	66	79.5	79.5	94.5	94.5	118.5	118.5
Rated Input Current (A) <sup>(7)</sup>	46	56	56	66	66	83	83	104
Rated Switching Frequency (kHz)	2.5	2.5	5	5	5	2.5	2.5	2.5
Maximum Motor (HP)/(kW) <sup>(5)</sup>	40/30	50/37	50/37	60/45	60/45	75/55	75/55	100/75
Watts Loss (kW) <sup>(8)</sup>	1	1.2	1.2	1.5	1.5	1.8	1.8	2.5
Frame Size	7		7		7		7	

Model: Current / Voltage	107/ 500-690		147/ 500-690		211/ 500-690		247/ 500-690	
	CT	VT	CT	VT	CT/VT	CT	VT	
Load <sup>(1)</sup>	CT	VT	CT	VT	CT/VT	CT	VT	
Power (kVA) <sup>(2)</sup>	107	147	147	195	210	210	314	
Rated Output Current (A) <sup>(3)</sup>	107	147	147	196	211	247	315	
Maximum Output Current (A) <sup>(4)</sup>	160	160	220.5	220.5	316.5	370.5	370.5	
Rated Input Current (A) <sup>(7)</sup>	107	147	147	196	211	247	315	
Rated Switching Frequency (kHz)	2.5	2.5	2.5	2.5	2.5	2.5	2.5	
Maximum Motor (HP)/(kW) <sup>(5)</sup>	100/75	150/110	150/110	200/150	200/150	250/185	300/220	
Watts Loss (kW) <sup>(8)</sup>	2.5	3	3	4.1	4.1	5.1	6	
Frame Size	8E		8E		8E	10E		

Model: Current / Voltage	315/ 500-690		343/ 500-690		418/ 500-690		472/ 500-690	
	CT	VT	CT	VT	CT	VT	CT	VT
Load <sup>(1)</sup>	CT	VT	CT	VT	CT	VT	CT	VT
Power (kVA) <sup>(2)</sup>	314	342	342	416	416	470	470	553
Rated Output Current (A) <sup>(3)</sup>	315	343	343	418	418	472	472	555
Maximum Output Current (A) <sup>(4)</sup>	472.5	472.5	514.5	514.5	627	627	708	708
Rated Input Current (A) <sup>(7)</sup>	315	343	343	418	418	472	472	555
Rated Switching Frequency (kHz)	2.5	2.5	2.5	2.5	2.5	2.5	2.5	2.5
Maximum Motor (HP)/(kW) <sup>(5)</sup>	300/220	350/250	350/250	400/300	400/300	500/370	500/370	600/450
Watts Loss (kW) <sup>(8)</sup>	6	6.8	6.8	8.2	8.2	11	11	12.3
Frame Size	10E		10E		10E		10E	

**Note:** CT = Constant Torque  
VT = Variable Torque

 Factory Default

## CHAPTER 9 - TECHNICAL SPECIFICATIONS

### 9.1.5 660-690V Power Supply

Model: Current / Voltage	100/ 660-690		127/ 660-690		179/ 660-690	225/ 660-690	
	CT	VT	CT	VT	CT/VT	CT	VT
Load <sup>(1)</sup>	CT	VT	CT	VT	CT/VT	CT	VT
Power (kVA) <sup>(2)</sup>	120	152	152	214	214	269	310
Rated Output Current (A) <sup>(3)</sup>	100	127	127	179	179	225	259
Maximum Output Current (A) <sup>(4)</sup>	150	150	190.5	197	268.5	337.5	337.5
Rated Input Current (A) <sup>(7)</sup>	100	127	127	179	179	225	259
Rated Switching Frequency (kHz)	2.5	2.5	2.5	2.5	2.5	2.5	2.5
Maximum Motor (HP)/(kW) <sup>(5)</sup>	100/75	150/110	150/110	200/150	200/150	250/185	300/220
Watts Loss (kW) <sup>(6)</sup>	2.5	3	3	4.1	4.1	5.1	6
Frame Size	8E		8E		8E	10E	

Model: Current / Voltage	259/ 660-690		305/ 660-690		340/ 660-690		428/ 660-690
	CT	VT	CT	VT	CT	VT	CT/VT
Load <sup>(1)</sup>	CT	VT	CT	VT	CT	VT	CT/VT
Power (kVA) <sup>(2)</sup>	310	365	365	406	406	512	512
Rated Output Current (A) <sup>(3)</sup>	259	305	305	340	340	428	428
Maximum Output Current (A) <sup>(4)</sup>	388.5	388.5	457.5	457.5	510	510	642
Rated Input Current (A) <sup>(7)</sup>	259	305	305	340	340	428	428
Rated Switching Frequency (kHz)	2.5	2.5	2.5	2.5	2.5	2.5	2.5
Maximum Motor (HP)/(kW) <sup>(5)</sup>	300/220	350/250	350/250	400/300	400/300	500/370	500/370
Watts Loss (kW) <sup>(6)</sup>	6	6.8	6.8	8.2	8.2	11	11
Frame Size	10E		10E		10E		10E

Model: Current / Voltage	107/ 500-690		147/ 500-690		211/ 500-690	247/ 500-690	
	CT	VT	CT	VT	CT/VT	CT	VT
Load <sup>(1)</sup>	CT	VT	CT	VT	CT/VT	CT	VT
Power (kVA) <sup>(2)</sup>	120	152	152	214	214	269	310
Rated Output Current (A) <sup>(3)</sup>	100	127	127	179	179	225	259
Maximum Output Current (A) <sup>(4)</sup>	150	150	190.5	197	268.5	337.5	337.5
Rated Input Current (A) <sup>(7)</sup>	100	127	127	179	179	225	259
Rated Switching Frequency (kHz)	2.5	2.5	2.5	2.5	2.5	2.5	2.5
Maximum Motor (HP)/(kW) <sup>(5)</sup>	100/75	150/110	150/110	200/150	200/150	250/185	300/220
Watts Loss (kW) <sup>(6)</sup>	2.5	3	3	4.1	4.1	5.1	6
Frame Size	8E		8E		8E	10E	

Model: Current / Voltage	315/ 500-690		343/ 500-690		418/ 500-690		472/ 500-690
	CT	VT	CT	VT	CT	VT	CT/VT
Load <sup>(1)</sup>	CT	VT	CT	VT	CT	VT	CT/VT
Power (kVA) <sup>(2)</sup>	310	365	365	406	406	512	512
Rated Output Current (A) <sup>(3)</sup>	259	305	305	340	340	428	428
Maximum Output Current (A) <sup>(4)</sup>	388.5	388.5	457.5	457.5	510	510	642
Rated Input Current (A) <sup>(7)</sup>	259	305	305	340	340	428	428
Rated Switching Frequency (kHz)	2.5	2.5	2.5	2.5	2.5	2.5	2.5
Maximum Motor (HP)/(kW) <sup>(5)</sup>	300/220	350/250	350/250	400/300	400/300	500/370	500/370
Watts Loss (kW) <sup>(6)</sup>	6	6.8	6.8	8.2	8.2	11	11
Frame Size	10E		10E		10E		10E

**Note:** CT = Constant Torque  
VT = Variable Torque

 Factory Default



**NOTES:**

(1) CT - Constant Torque

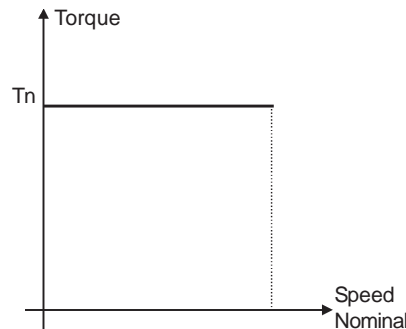

VT - Variable Torque

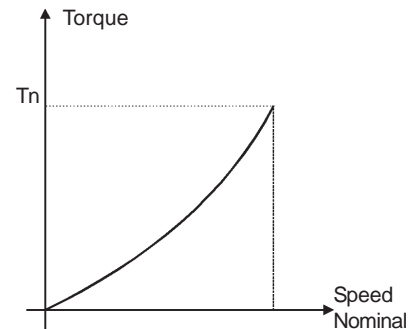

**Figure 9.1 - Load Characteristics**

(2)

The power rating in kVA is determined by the following equation:

$$P(\text{kVA}) = \frac{\sqrt{3} \cdot \text{Input Voltage (V)} \times \text{Current Rating (A)}}{1000}$$

The values shown on the Tables 9.1.2 to 9.1.5 were calculated considering the inverter rated current rating and an input voltage of 230V for 220-230V models, 460V for 380-480V models, 575V for 500-600V models and 690V for 660-690V models.

(3)

Rated Output Current is valid for the following conditions:

- Relative Air Humidity: 5% to 90%, non condensing;
- Altitude : 1000m (3,300 ft) – nominal conditions.  
From 1000m to 4000m (3,300ft to 13,200 ft) – with 1% current reduction for each 100m (330 ft) above 1000m (3,300 ft).
- Ambient Temperature: 0 °C to 40 °C (32 °F to 104 °F) - nominal conditions.  
From 0 °C to 55 °C (32 °F to 131 °F) - with 2% current derating for each 1°C (1.8 °F) degree above 40 °C (104 °F).
- The rated current values are valid for the indicated switching frequencies.
- The 10kHz switching frequency is not possible for the 2.9A to 79A/500-600V, 107A to 472A/500-690V and 100A to 428A/660-690V models.
- The operation at 10kHz is possible for V/F control mode and vector control with encoder mode. In this case it's necessary to derate the output current according to table 9.1.

Models	Load Type	Switching Frequency	Output Current Derating - %
6A to 45A / 220-230V	CT/VT	10kHz	0.8
	CT		
54A to 130A/220-230V	VT	5kHz	Contact WEG
		10kHz	
3.6A to 24A / 380-480V	CT/VT	10kHz	0.7
	CT		
30A to 142A / 380-480V	VT	5kHz	Contact WEG
		10kHz	
180A to 600A / 380-480V	CT/VT	5kHz	
		10kHz	
63A / 500-600V	VT	5kHz	0.8
79A / 500-600V	CT		Contact WEG
	VT		
107A to 472A / 500-690V	CT		
	VT		
100A to 428A / 660-690V	CT		
	VT		

**Table 9.1** - Output current derating for switching frequency  $\geq$  rated switching frequency

**(4)**

- Maximum Current:  $1.5 \times I_{\text{Nominal}}$  (for 60 seconds every 10 minutes).  
 $I_{\text{Nominal}}$  = Rated Current for CT applications considering the applicable derating (depending on altitude or ambient temperature as specified in note (3)).
- The maximum output current is the same for CT and VT. This way the inverter has a lower overload capacity when VT current is used.

**(5)**

The indicated maximum motor HP/kW ratings are based on WEG 230V/460V/575V 4 pole motors and normal duty loads. A precise inverter sizing must consider the actual motor nameplate and application data.

**(6)**

Rated input current for single-phase operation.

Note: The 6A , 7A and 10A / 220-230 V models can be operated with 2 input phases only (single-phase operation) without output current derating.

**(7)**

Rated input current for three-phase operation:

This is a conservative value. In practice the value of this current depends on the line impedance. Please see table 9.2:

X (%)	$I_{\text{input (rms)}} (\%)$
0.5	131
1.0	121
2.0	106
3.0	99
4.0	96
5.0	96

**Table 9.2** - X = Line impedance drop @ rated inverter output current;  
 $I_{\text{input (rms)}} = \% \text{ of the rated output current}$

**(8)**

Loss considering rated work conditions (rated output current and rated switching frequency).

9.2 ELECTRONICS/GENERAL DATA

CONTROL	METHOD	<input checked="" type="checkbox"/> Voltage Source V/F (Scalar), or <input checked="" type="checkbox"/> Vector Control with Encoder Feedback, or <input checked="" type="checkbox"/> Sensorless Vector Control (without Encoder) <input checked="" type="checkbox"/> PWM SVM (Space Vector Modulation) <input checked="" type="checkbox"/> Current, Flux and Speed Digital Regulators Scan Time: <input checked="" type="checkbox"/> Current Regulators: 0.2 ms (5 kHz) <input checked="" type="checkbox"/> Flux Regulator: 0.4 ms (2.5 kHz) <input checked="" type="checkbox"/> Speed Regulator / Speed Measurement: 1.2 ms
	OUTPUT FREQUENCY	<input checked="" type="checkbox"/> 0 to 3,4 x motor rated frequency (P403). This rated frequency can be set from 0Hz to 300Hz in scalar mode and from 30Hz to 120Hz in vector mode.
PERFORMANCE (Vector Mode)	SPEED CONTROL	<u>VVW:</u> <input checked="" type="checkbox"/> Regulation: 1% of Base Speed <input checked="" type="checkbox"/> Speed Range: 1:30 <u>Sensorless:</u> <input checked="" type="checkbox"/> Regulation: 0.5% of Base Speed <input checked="" type="checkbox"/> Speed Range: 1:100 <u>With Encoder: (with EBA or EBB Board)</u> <input checked="" type="checkbox"/> Regulation: +/- 0.01% of Base Speed with 14 bit Analog Input (EBA Board); +/- 0.01% of Base Speed with Digital Reference (Keypad, Serial Port, Fieldbus, Electronic Potentiometer, Multispeed); +/- 0.1% of Base Speed with 10 bit Analog Input (CC9 Board).
	TORQUE CONTROL	<input checked="" type="checkbox"/> Range: 10 to 180%, Regulation: +/-10% of Rated Torque (with encoder) <input checked="" type="checkbox"/> Range: 20 to 180%, Regulation: +/-10% of Rated Torque (sensorless above 3Hz)
INPUTS (CC9 Board)	ANALOG	<input checked="" type="checkbox"/> 2 Non Isolated Differential Inputs: (0 to 10) V, (0 to 20) mA or (4 to 20) mA; Impedance: 400k $\Omega$ [(0 to 10) V], 500 $\Omega$ [(0 to 20) mA or (4 to 20) mA]; Resolution: 10 bit, Programmable Functions;
	DIGITAL	<input checked="" type="checkbox"/> 6 Isolated Inputs: 24 Vdc; Programmable Functions
OUTPUTS (CC9 Board)	ANALOG	<input checked="" type="checkbox"/> 2 Non Isolated Outputs: (0 to 10) V; $RL \geq 10 \text{ k}\Omega$ (1 mA Maximum); Resolution: 11 bits; Programmable Functions.
	RELAY	<input checked="" type="checkbox"/> 2 Relays: NO/NC contacts available; 240 Vac, 1 A; Programmable Functions. <input checked="" type="checkbox"/> 1 Relay: NO contact available; 240 Vac, 1 A; Programmable Functions.
SAFETY	PROTECTION	<input checked="" type="checkbox"/> Overcurrent/Output Short-circuit (Trip Point: >2 x Rated Current for CT application) <input checked="" type="checkbox"/> DC Link Under/Overvoltage <input checked="" type="checkbox"/> Power Supply Undervoltage/Phase Fault <sup>(1)</sup> <input checked="" type="checkbox"/> Inverter Overtemperature <input checked="" type="checkbox"/> Dynamic Braking Resistor Overload <input checked="" type="checkbox"/> Motor/Inverter Overload (Ixt) <input checked="" type="checkbox"/> External Fault <input checked="" type="checkbox"/> CPU/EPROM Error <input checked="" type="checkbox"/> Output Ground Fault <input checked="" type="checkbox"/> Programming Error

## CHAPTER 9 - TECHNICAL SPECIFICATIONS

KEYPAD (HMI)	STANDARD (HMI-CFW09-LCD)	<input checked="" type="checkbox"/> 8 Keys: Start, Stop, Increase, Decrease, FWD/REV, JOG, <input checked="" type="checkbox"/> Local/Remote and Program <input checked="" type="checkbox"/> LCD display: 2 lines x 16 characters <input checked="" type="checkbox"/> LED display: 4 Digits with 7 segments <input checked="" type="checkbox"/> LED's for FWD/REV and LOC/REM Indication <input checked="" type="checkbox"/> Display Accuracy: - Current: 5% of Rated Current - Speed Resolution: 1 rpm <input checked="" type="checkbox"/> Remote mounting possibility, Cables available up to 10m (30ft)
DEGREE OF PROTECTION	NEMA1/IP20	<input checked="" type="checkbox"/> NEMA 1/ IP20: 3.6A to 240A/380-480V models and all 220-230V and 500-600V models and 107A to 211A/500-690V and 100A to 179A/660-690V.
	PROTECTED CHASSIS/IP20	<input checked="" type="checkbox"/> Protected chassis/IP20: 361A to 600A/380-480V models, 247A to 472A/500-690V and 225A to 428A/660-690V.

(1) Available in models  $\geq 30A / 220-230V$  or  $\geq 30A / 380-480V$  or  $\geq 22A / 500 -600V$  or for all 500-690V and 660-690V models.

### 9.2.1 Applicable Standards

GENERAL	<input checked="" type="checkbox"/> <b>UL508C</b> - Power conversion equipment <input checked="" type="checkbox"/> <b>UL840</b> - Insulation coordination including clearances and creepage distances for electrical equipment <input checked="" type="checkbox"/> <b>EN50178</b> - Electronic equipment for use in power installations <input checked="" type="checkbox"/> <b>EN60204-1</b> - Safety of machinery. Electrical equipment of machines. Part 1: General requirements. <i>Provisions for compliance:</i> the final assembler of the machine is responsible for installing: - an emergency-stop device - a supply disconnecting device. <input checked="" type="checkbox"/> <b>EN60146 (IEC 146)</b> - Semiconductor convertors <input checked="" type="checkbox"/> <b>EN61800-2</b> - Adjustable speed electrical power drive systems - Part 2: General requirements - Rating specifications for low voltage adjustable frequency AC power drive systems.
EMC	<input checked="" type="checkbox"/> <b>EN 61800-3</b> - Adjustable speed electrical power drive systems - Part 3: EMC product standard including specific test methods <input checked="" type="checkbox"/> <b>EN55011</b> - Limits and methods of measurement of radio disturbance characteristics of industrial, scientific and medical (ISM) radio-frequency equipment <input checked="" type="checkbox"/> <b>CISPR11</b> - Industrial, scientific and medical (ISM) radio-frequency equipment - Electromagnetic disturbance characteristics - Limits and methods of measurement <input checked="" type="checkbox"/> <b>EN61000-4-2</b> - Electromagnetic compatibility (EMC) - Part 4: Testing and measurement techniques - Section 2: Electrostatic discharge immunity test <input checked="" type="checkbox"/> <b>EN61000-4-3</b> - Electromagnetic compatibility (EMC) - Part 4: Testing and measurement techniques - Section 3: Radiated, radio-frequency, electromagnetic field immunity test <input checked="" type="checkbox"/> <b>EN61000-4-4</b> - Electromagnetic compatibility (EMC) - Part 4: Testing and measurement techniques - Section 4: Electrical fast transient/burst immunity test <input checked="" type="checkbox"/> <b>EN61000-4-5</b> - Electromagnetic compatibility (EMC) - Part 4: Testing and measurement techniques - Section 5: Surge immunity test <input checked="" type="checkbox"/> <b>EN61000-4-6</b> - Electromagnetic compatibility (EMC)- Part 4: Testing and measurement techniques - Section 6: Immunity to conducted disturbances, induced by radio-frequency fields
MECHANICAL	<input checked="" type="checkbox"/> <b>EN60529</b> - Degrees of protection provided by enclosures (IP code) <input checked="" type="checkbox"/> <b>UL50</b> - Enclosures for electrical equipment

9.3 OPTIONAL DEVICES

9.3.1 I/O Expansion Board EBA

COMMUNICATION	SERIAL INTERFACE	<input checked="" type="checkbox"/> Isolated RS-485 Serial Interface (the RS-485 and RS-232 serial interfaces cannot be used simultaneously)
INPUTS	ANALOG	<input checked="" type="checkbox"/> 1 Bipolar Analog Input (AI4): -10V to +10V; (0 to 20) mA or (4 to 20) mA; Linearity: 14 bits (0.006% of 10V range) Programmable Functions
	INCREMENTAL ENCODER	<input checked="" type="checkbox"/> Incremental Encoder Feedback Input: Internal 12 V dc, 200 mA max isolated power supply Differential inputs A, $\bar{A}$ , B, $\bar{B}$ , Z and $\bar{Z}$ signals (100 kHz max) 14 bits resolution. Used as speed feedback for the speed regulator and digital speed measurement
	DIGITAL	<input checked="" type="checkbox"/> 1 Programmable Isolated 24Vdc Digital Input (DI7) <input checked="" type="checkbox"/> Programmable Digital Input (DI8). For motor PTC-thermistor Actuation: 3.9 k $\Omega$ Release: 1.6 k $\Omega$
OUTPUTS	ANALOG	<input checked="" type="checkbox"/> 2 Bipolar Analog Outputs (AO3/AO4): -10V to +10V Linearity: 14 bits (0.006% of +/- 10V range) Programmable Functions
	ENCODER	<input checked="" type="checkbox"/> Buffered Encoder Output: Input signal repeater; Isolated differential outputs
	DIGITAL	<input checked="" type="checkbox"/> 2 Isolated Transistor Outputs (DO1/DO2): Open collector, 24 Vdc, 50 mA Programmable Functions

9.3.2 I/O Expansion Board EBB

COMMUNICATION	SERIAL INTERFACE	<input checked="" type="checkbox"/> Isolated RS-485 Serial Interface (the RS-485 and RS-232 serial interfaces cannot be used simultaneously)
INPUTS	ANALOG	<input checked="" type="checkbox"/> 1 Isolated Analog Input (AI3): 0V to 10V or (0 to 20)mA or (4 to 20)mA Resolution: 10 bits; Programmable Functions
	INCREMENTAL ENCODER	<input checked="" type="checkbox"/> Incremental Encoder Feedback Input: Internal 12 Vdc, 200mA max isolated power supply Differential inputs signals A, $\bar{A}$ , B, $\bar{B}$ , Z and $\bar{Z}$ (100 kHz max) 14 bit resolution. Used as speed feedback for the speed regulator and digital speed measurement
	DIGITAL	<input checked="" type="checkbox"/> 1 Programmable Isolated 24Vdc Digital Input (DI7) <input checked="" type="checkbox"/> 1 Programmable Digital Input (DI8): For motor PTC-thermistor, Actuation: 3.9 k $\Omega$ Release: 1.6 k $\Omega$
OUTPUTS	ANALOG	<input checked="" type="checkbox"/> 2 Isolated Analog Outputs (AO1'/AO2'): (0 to 20)mA or (4 to 20)mA; Linearity: 11 bits (0.05% of full scale); Programmable Functions (Same as AO1 and AO2 of CC9 control board).
	ENCODER	<input checked="" type="checkbox"/> Buffered Encoder Output: Input signal repeater Isolated differential outputs
	DIGITAL	<input checked="" type="checkbox"/> 2 Isolated Transistor Outputs (DO1/DO2): Open collector 24Vdc, 50mA; Programmable Functions

9.4 MECHANICAL DATA

SIZE 1

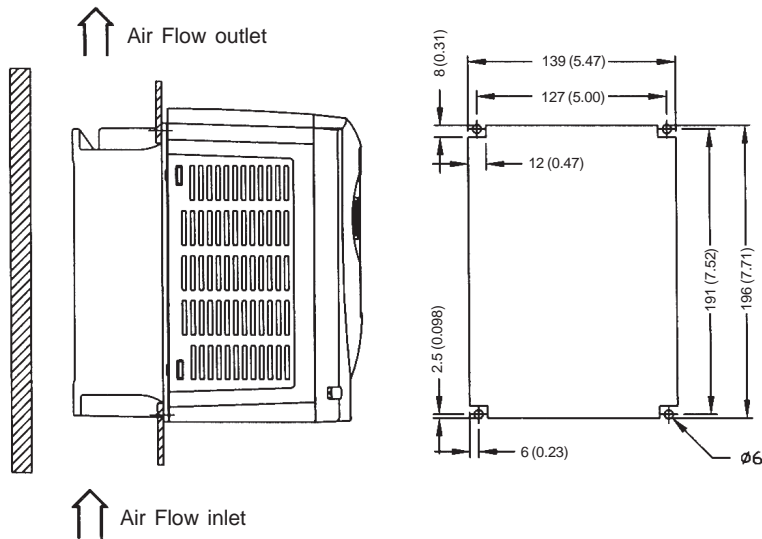
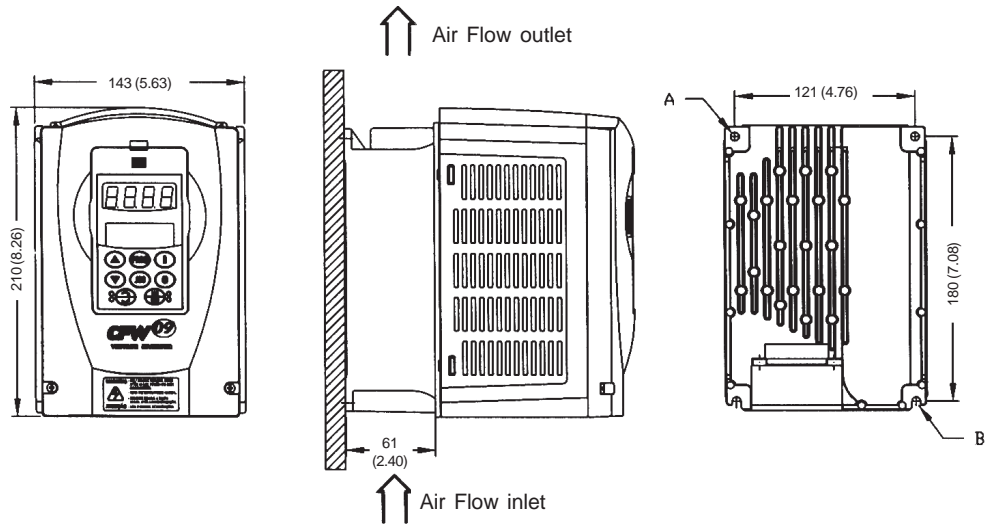
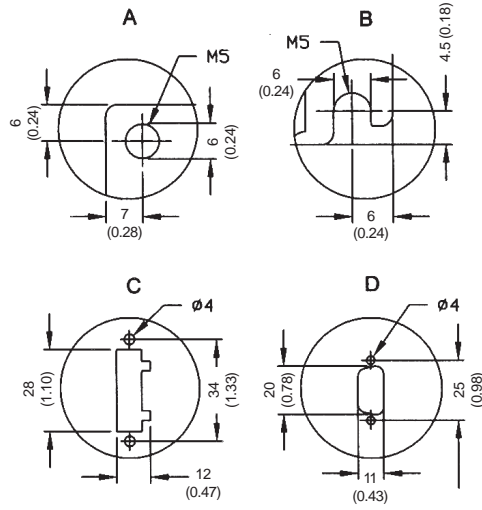
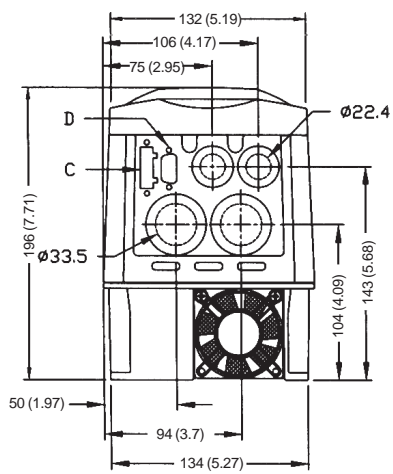

Figure 9.2 - Size 1 - Dimensions in mm (inch)

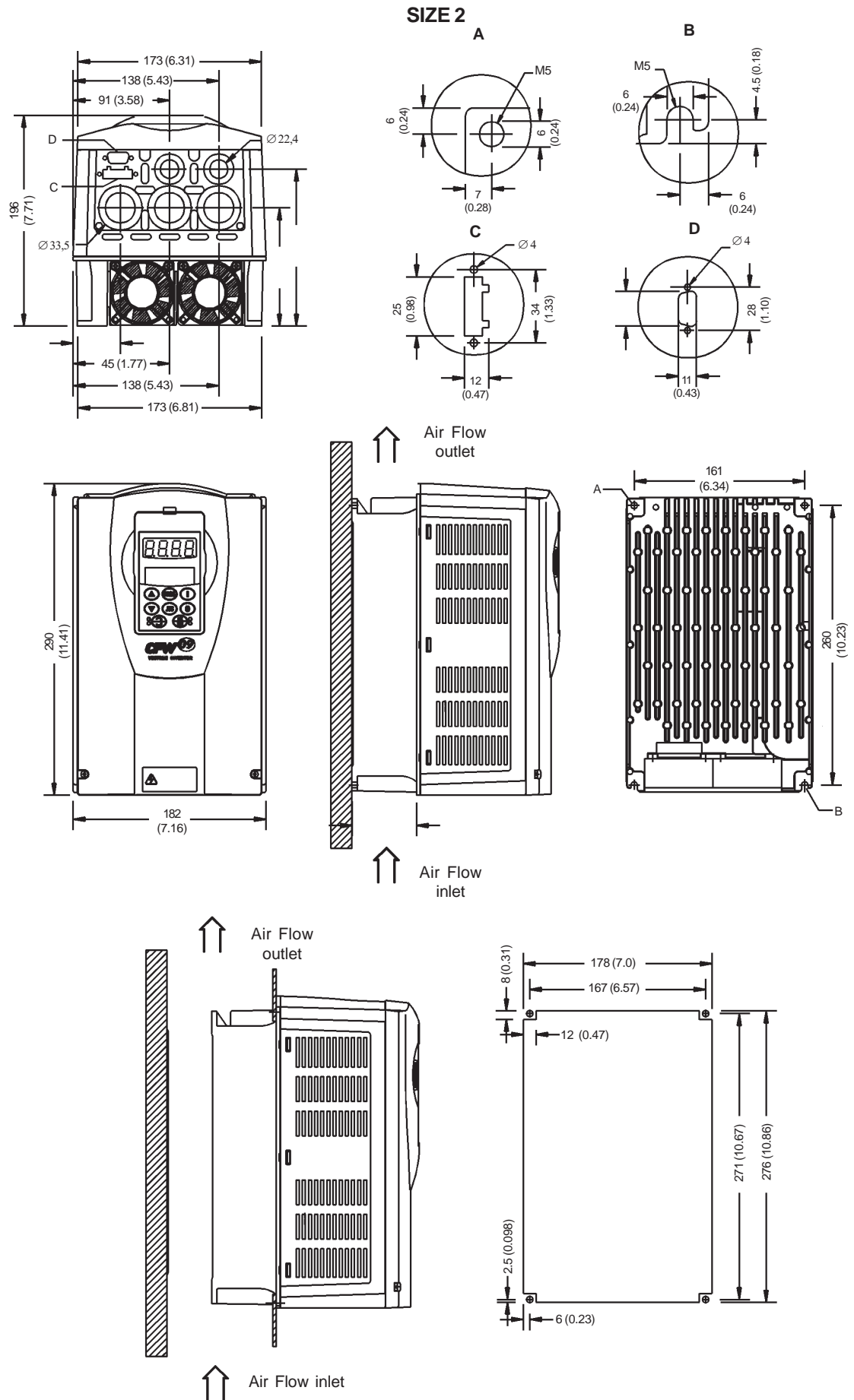

Figure 9.3 - Size 2 - Dimensions in mm (inch)

SIZE 3

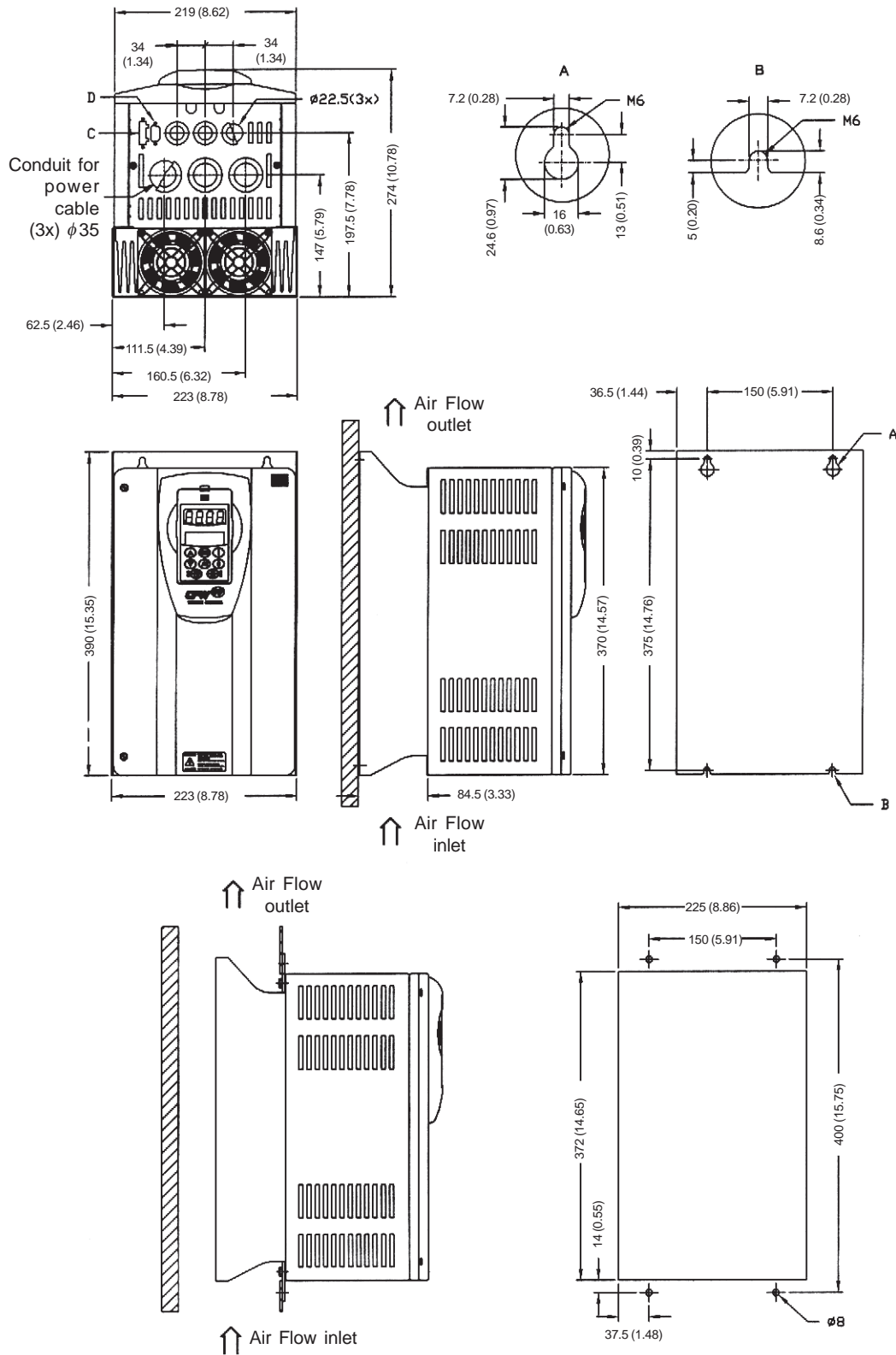

Figure 9.4 - Size 3 - Dimensions in mm (inch)

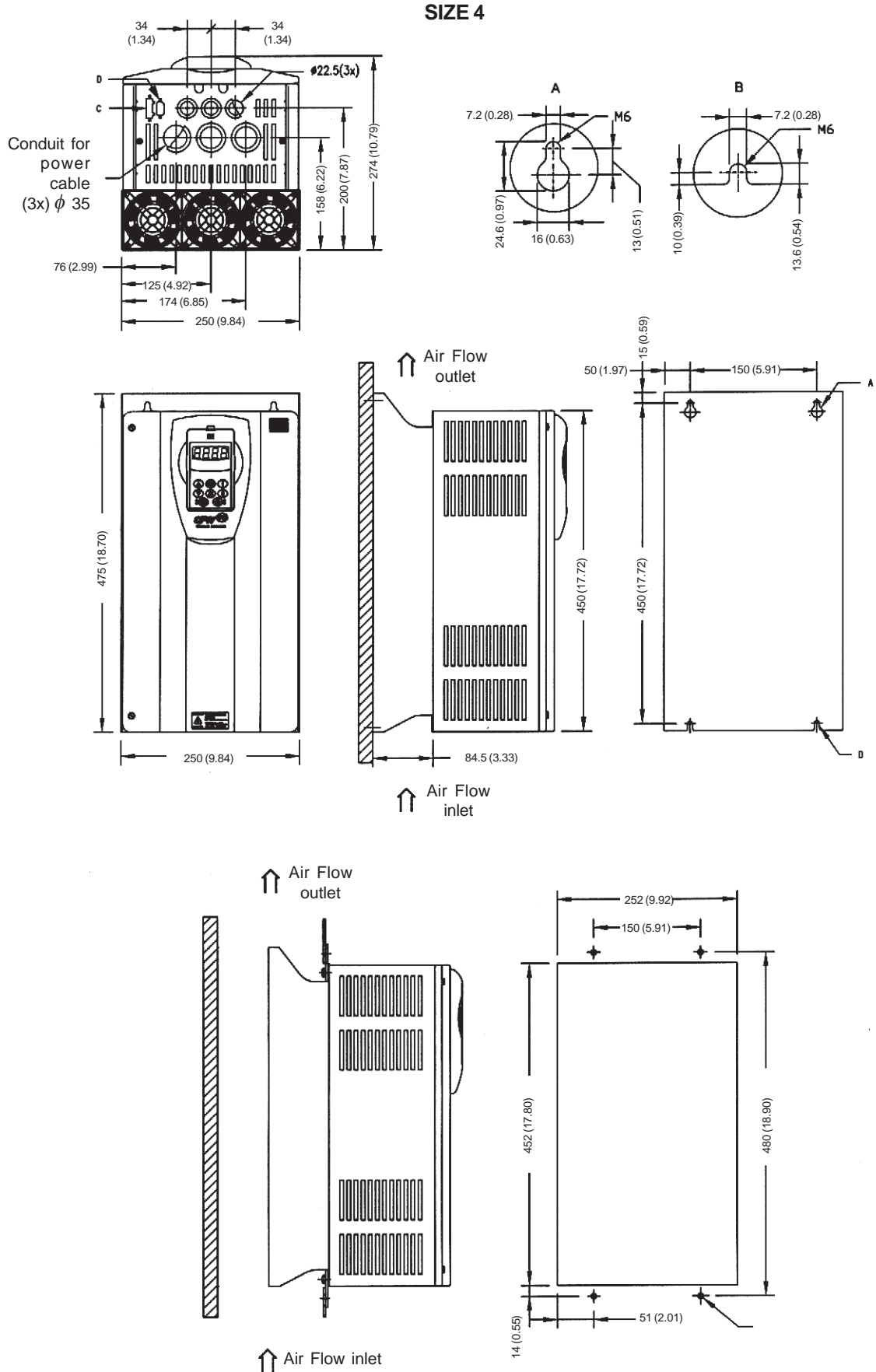

Figure 9.5 - Size 4 - Dimensions in mm (inch)

SIZE 5

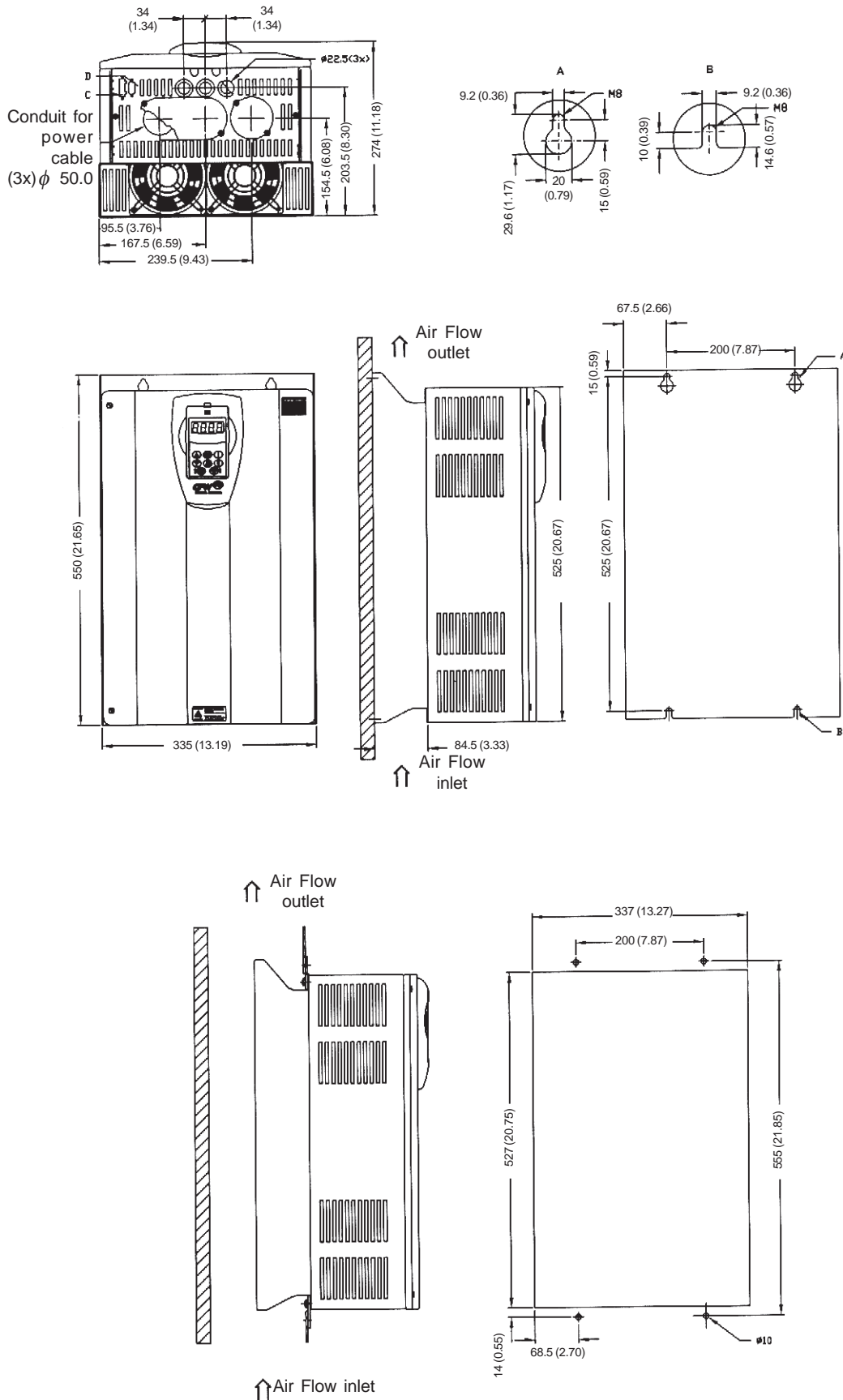

Figure 9.6 - Size 5 - Dimensions in mm (inch)

SIZE 6

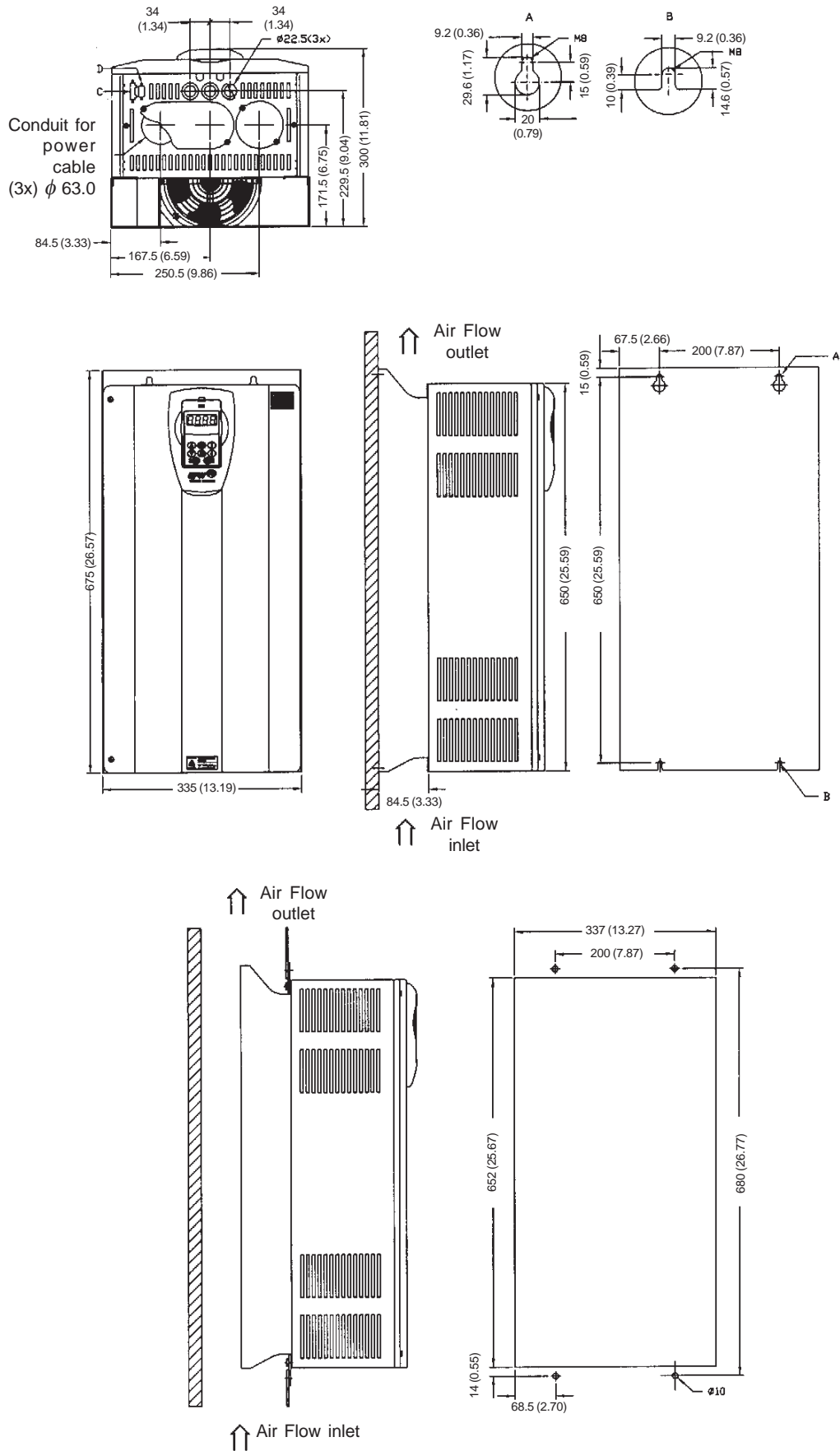

Figure 9.7 - Size 6 - Dimensions in mm (inch)

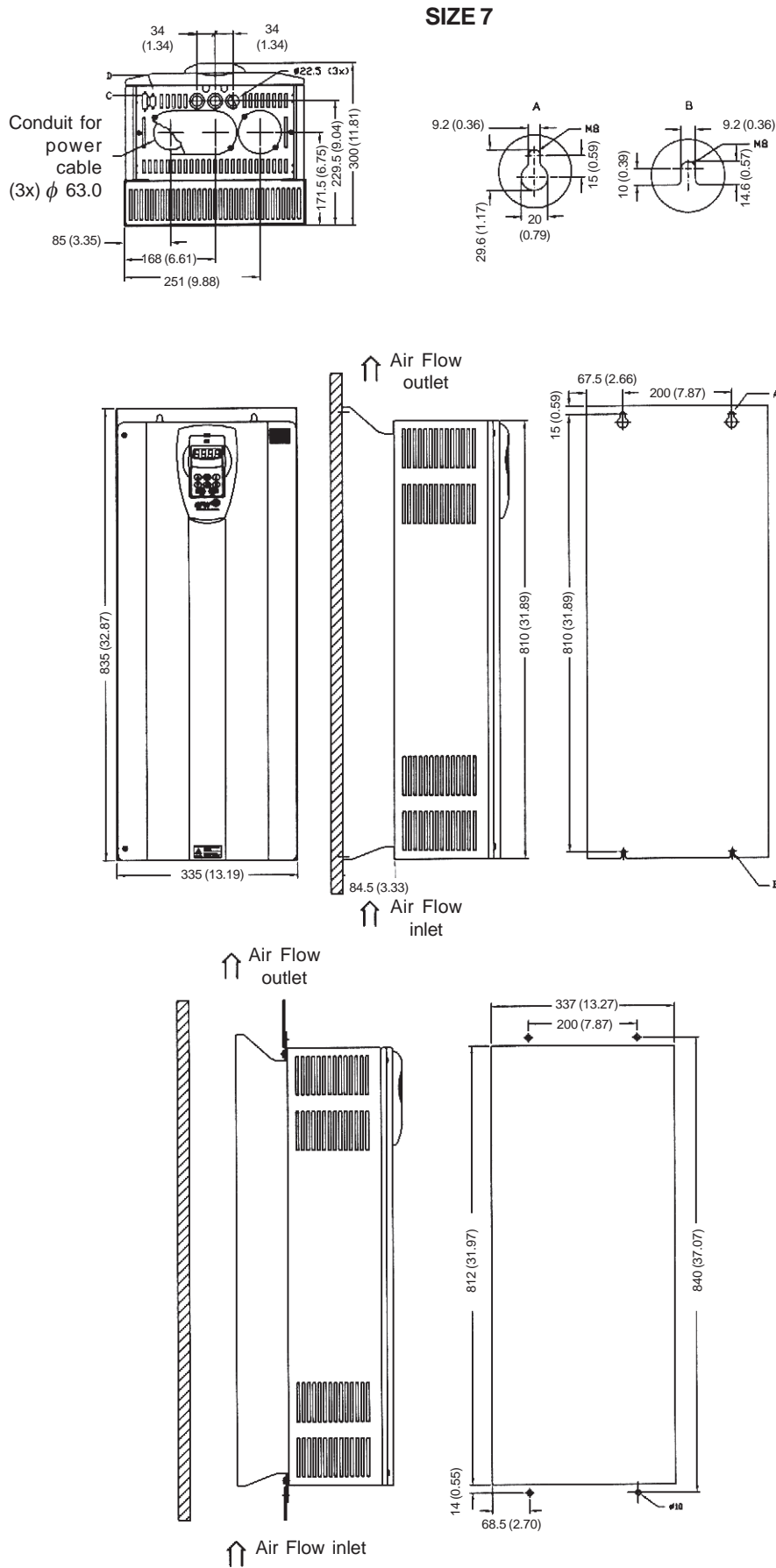
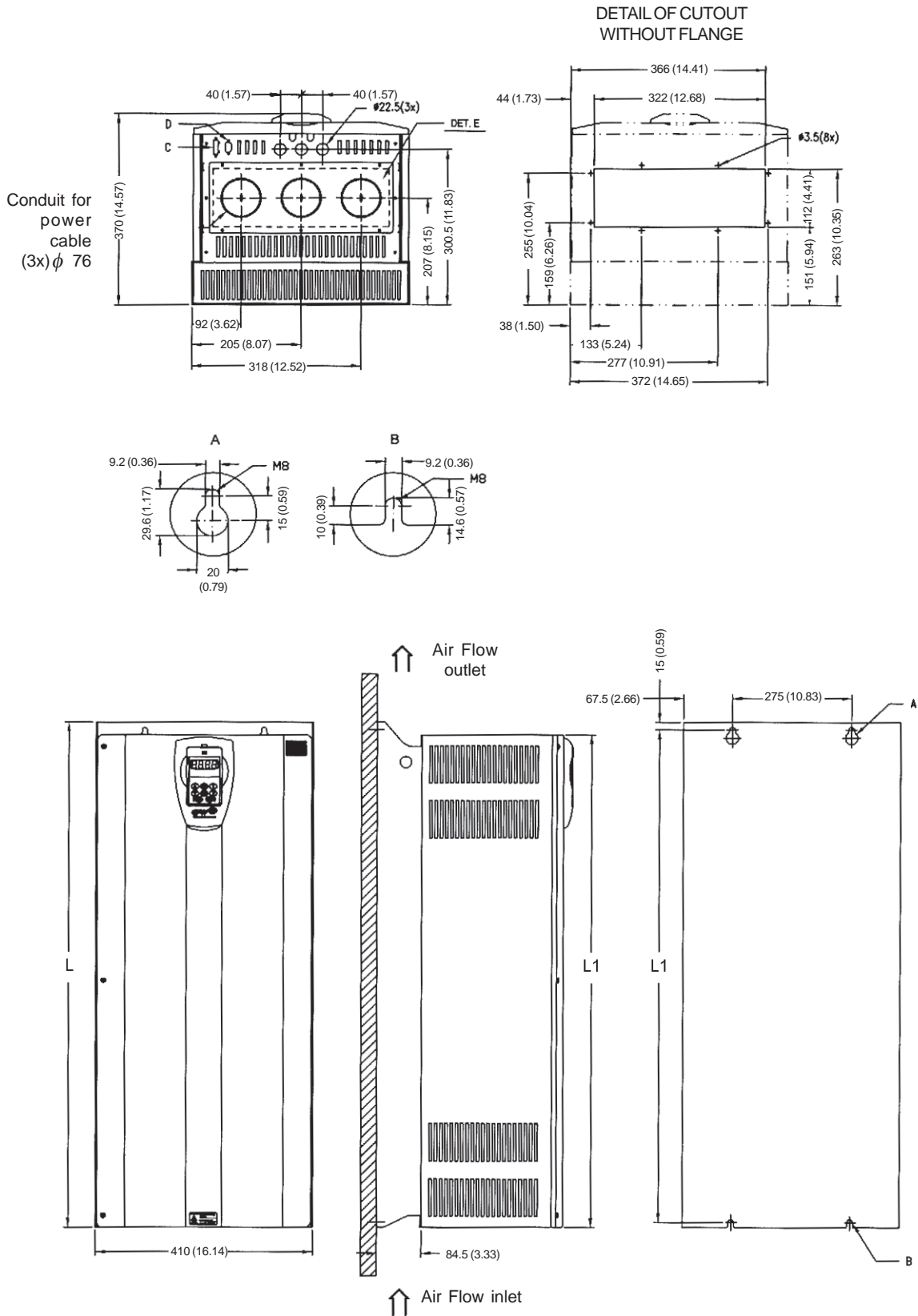
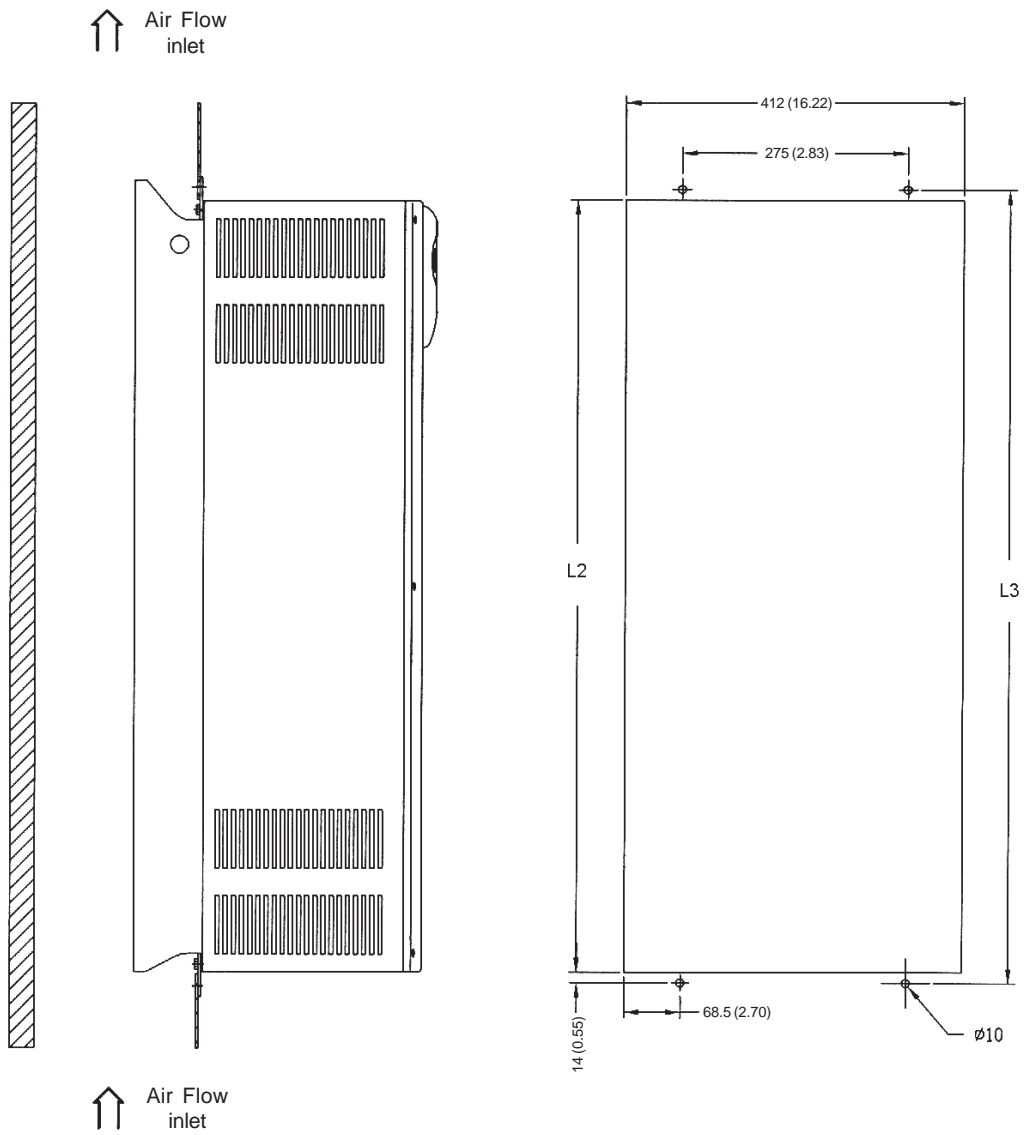

Figure 9.8 - Size 7 - Dimensions in mm (inch)

SIZE 8 AND 8E





Length Dimensions	L		L1		L2		L3	
	mm	in	mm	in	mm	in	mm	in
Size 8	975	38.38	950	37.4	952	37.48	980	38.58
Size 8E		1145	1122.5	44.19	1124.5	44.27	1152.5	45.37

45.08

Figure 9.9 (cont.) - Size 8 and 8E - Dimensions in mm (inch)

SIZE 9

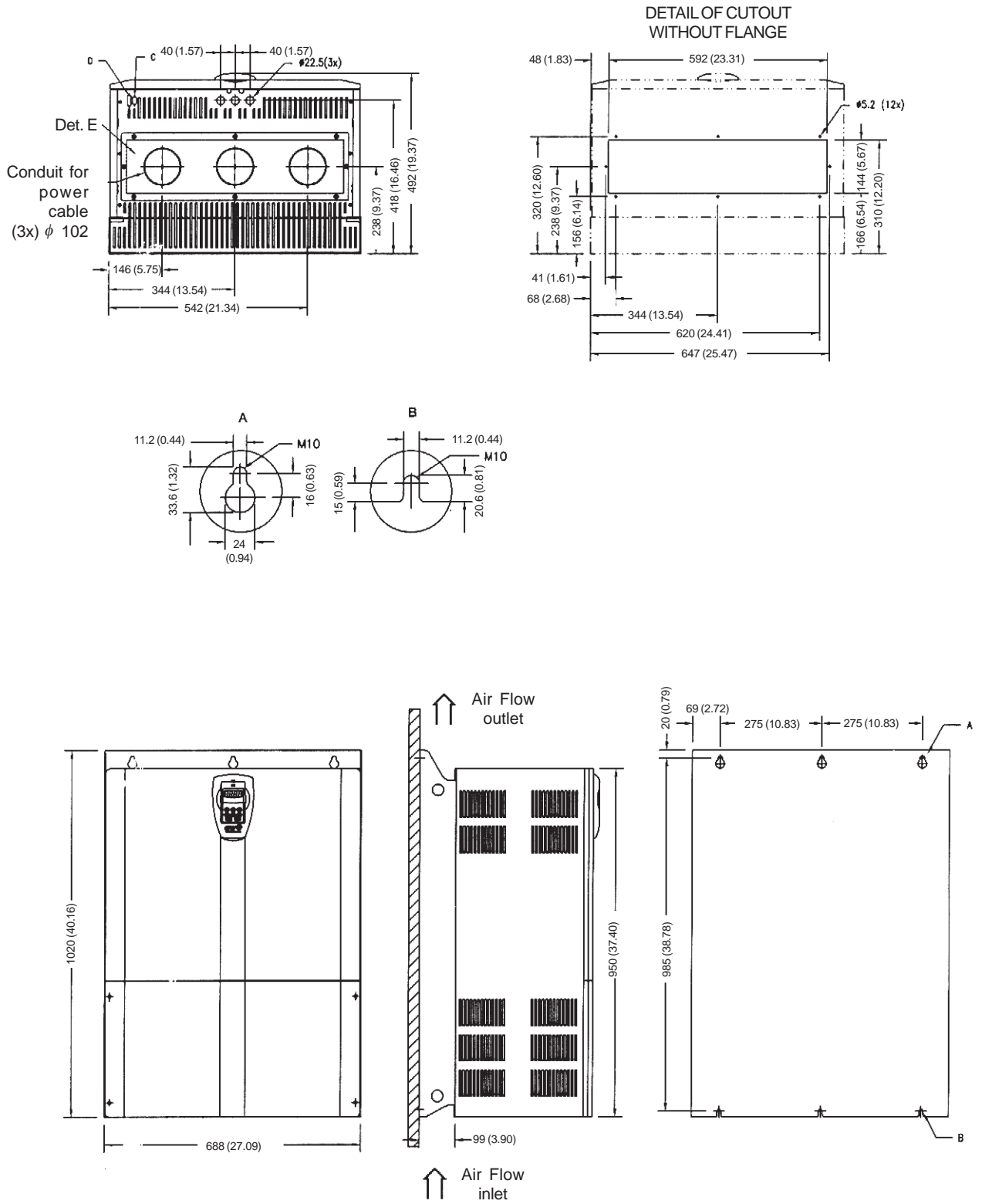
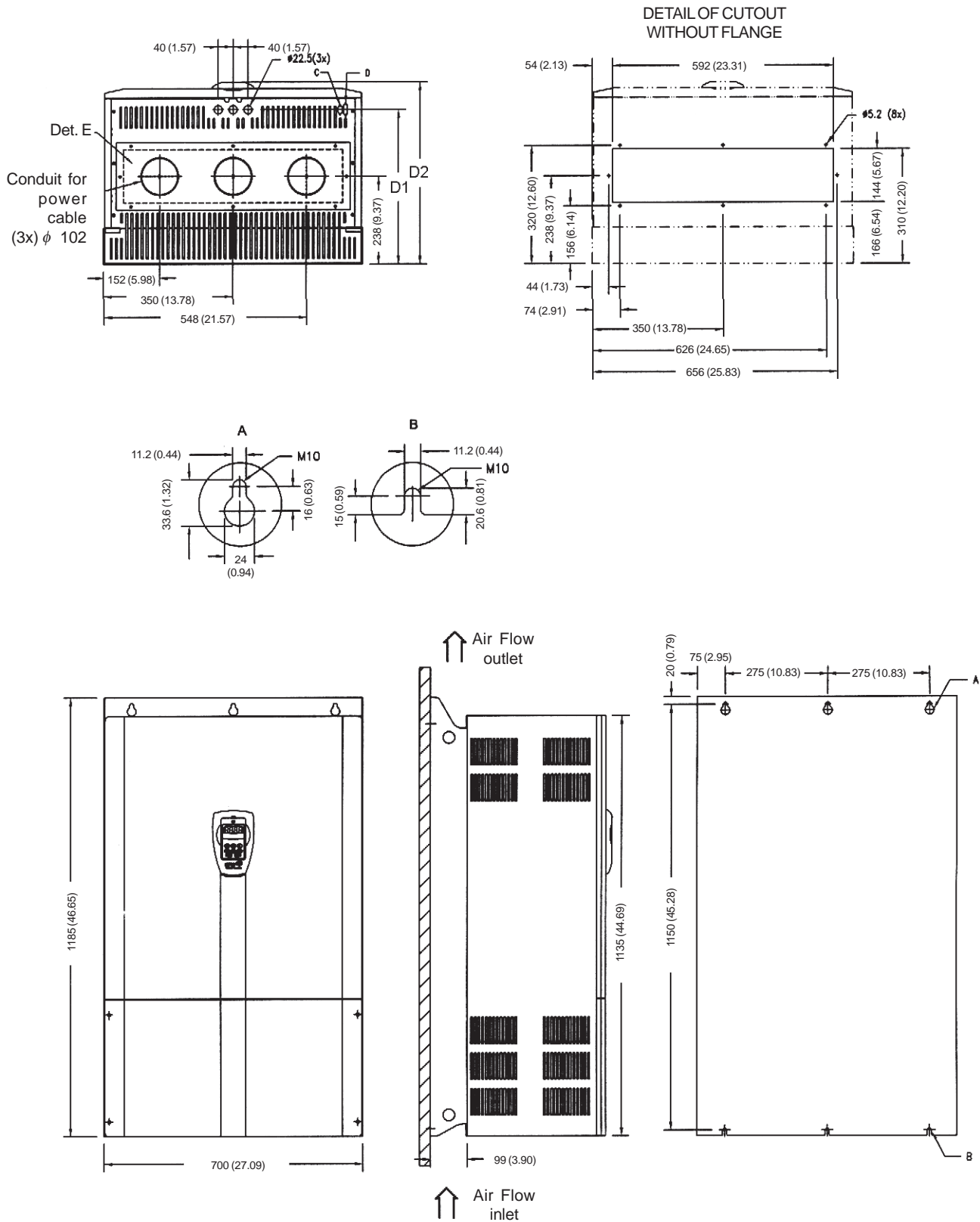

Figure 9.10 - Size 9 - Dimensions in mm (inch)

SIZE 10 AND 10E



Length Dimensions	D1		D2	
	mm	in	mm	in
Size 10	418	16.45	492	19.37
Size 10E	508	20	582	22.91

Figure 9.11 - Size 10 and 10E - Dimensions in mm (inch)

180A-240A/380-480V Models (size 8)

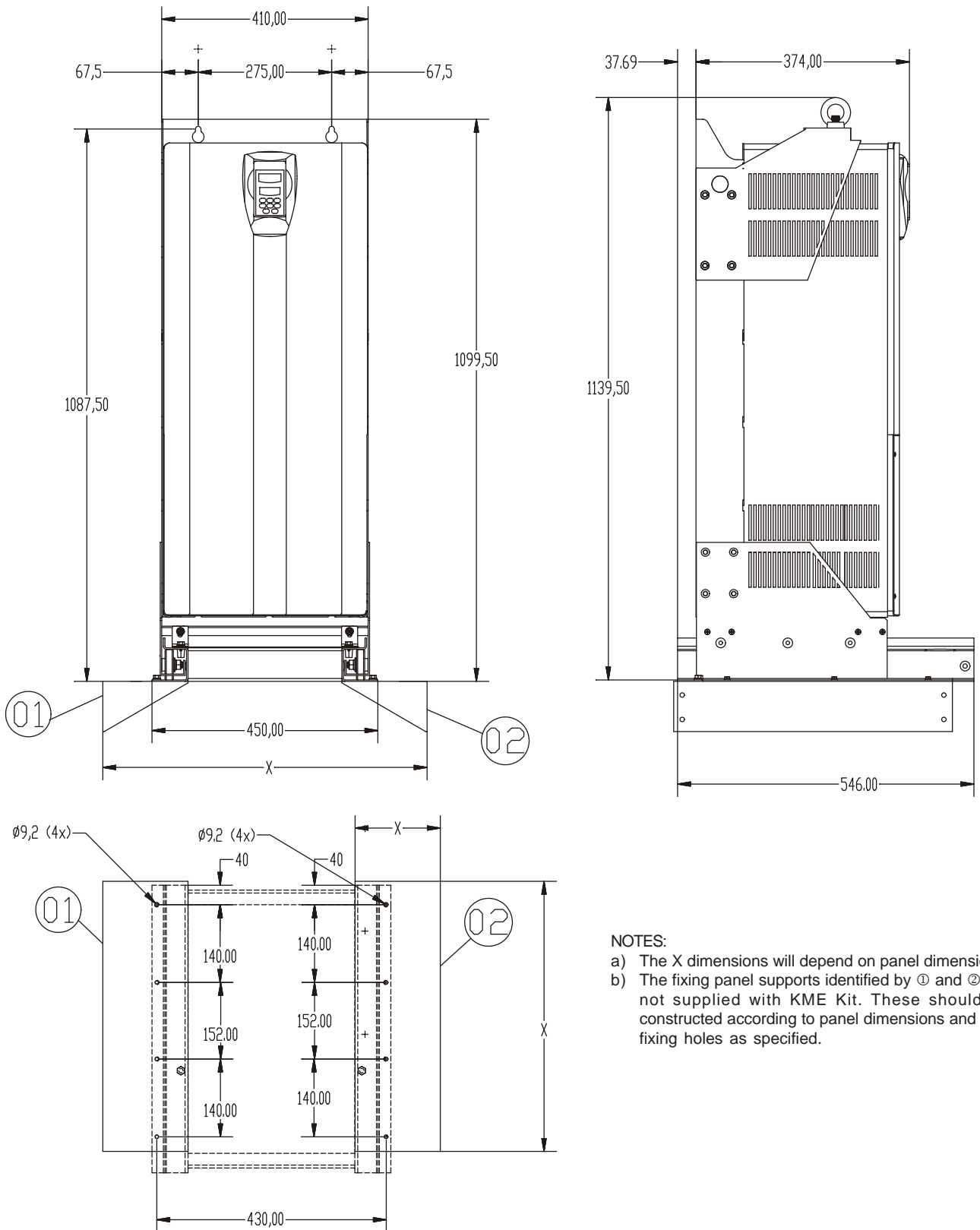

NOTES:

- a) The X dimensions will depend on panel dimensions.
- b) The fixing panel supports identified by ① and ② are not supplied with KME Kit. These should be constructed according to panel dimensions and with fixing holes as specified.

Figure 9.12 a) - KIT-KME for Size 8 - Panel Width = 600mm (23.62 in)

180A-240A/380-480V Models (size 8)

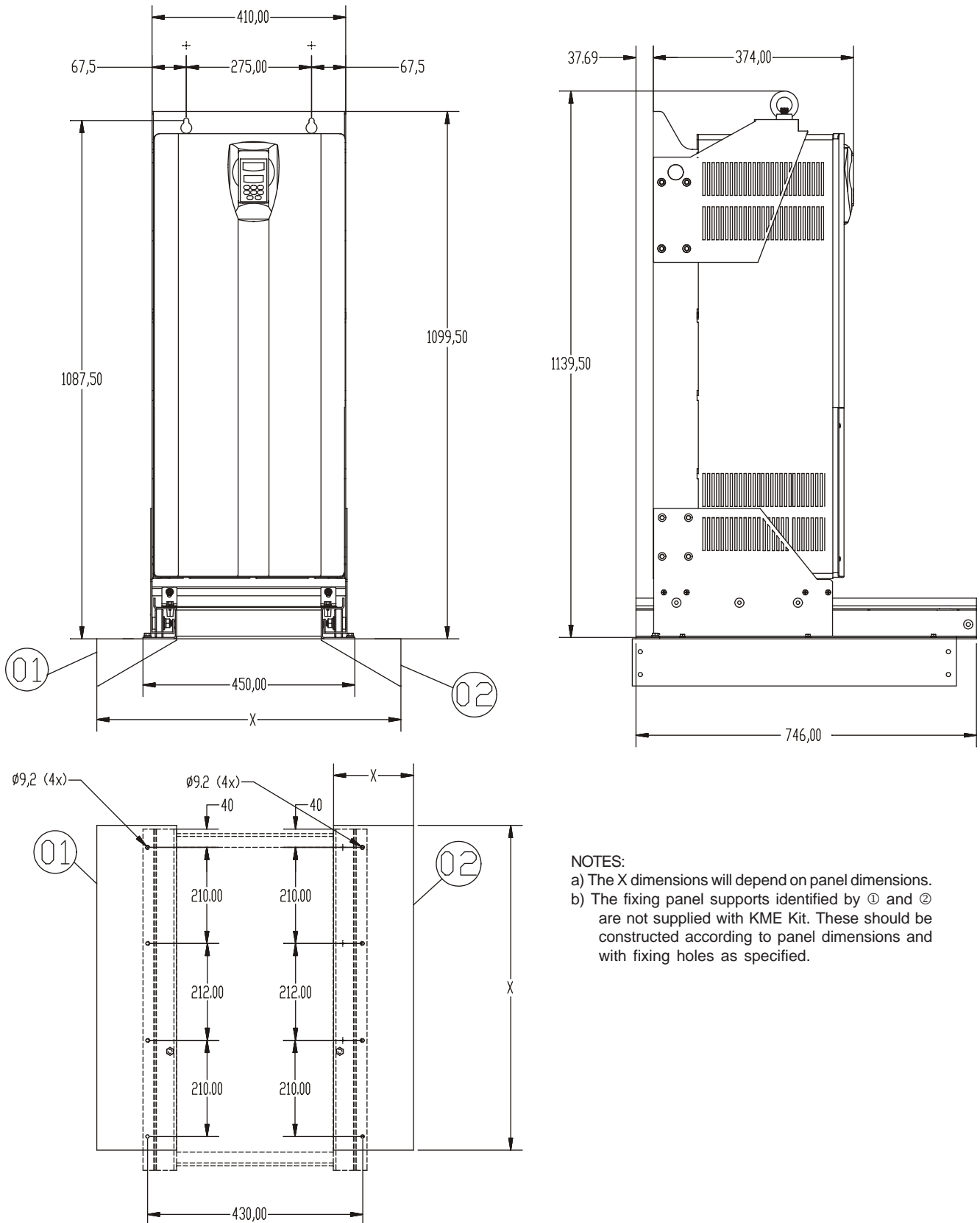

- NOTES:
- The X dimensions will depend on panel dimensions.
  - The fixing panel supports identified by ① and ② are not supplied with KME Kit. These should be constructed according to panel dimensions and with fixing holes as specified.

Figure 9.12 b) - KIT-KME for Size 8 - Panel Width = 800mm (31.50 in)

107A to 211A/500-600V Models (size 8E)  
and 100A to 179A/660-690 V Models (size 8E)

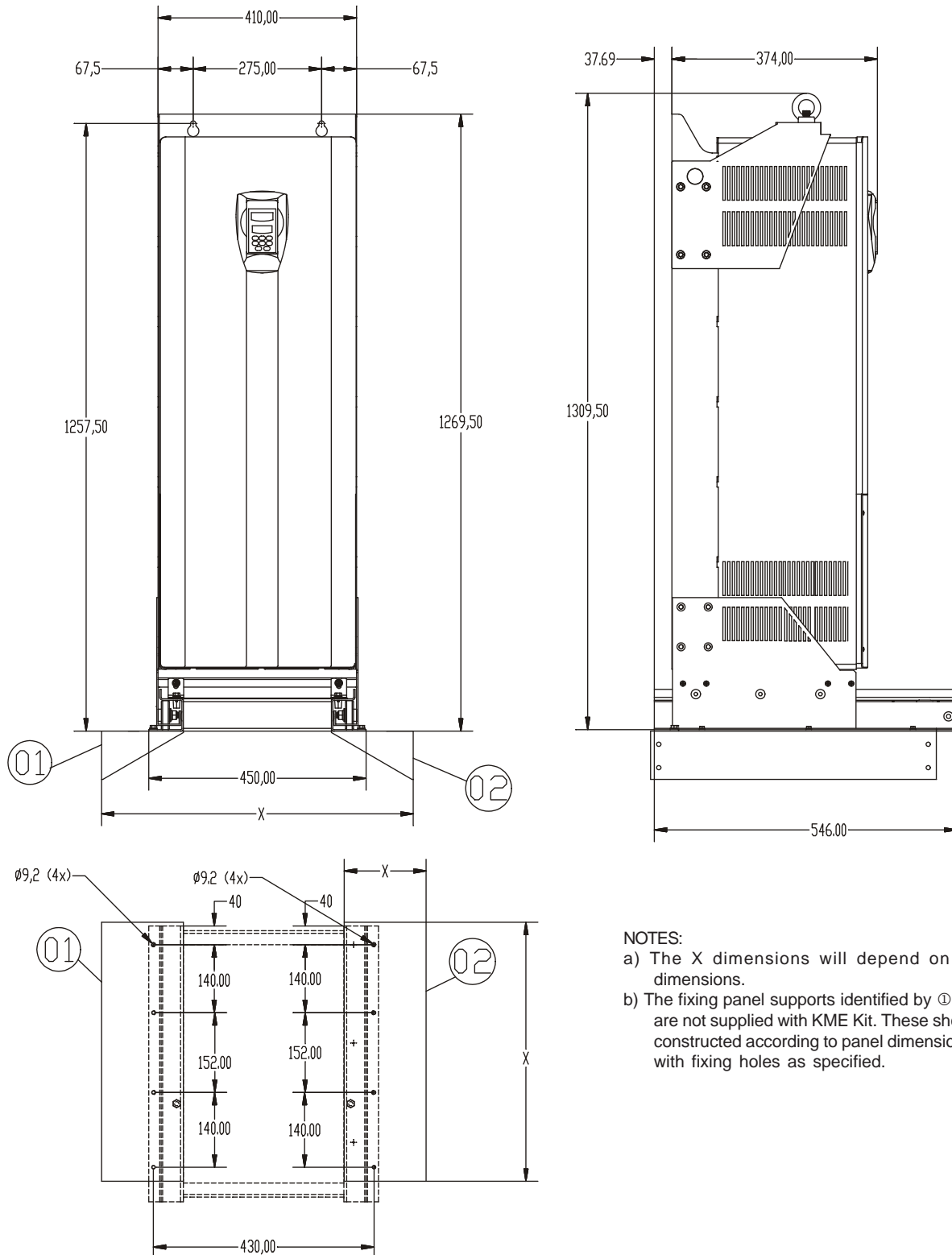

NOTES:

- The X dimensions will depend on panel dimensions.
- The fixing panel supports identified by ① and ② are not supplied with KME Kit. These should be constructed according to panel dimensions and with fixing holes as specified.

Figure 9.12 c) - KIT-KME for Size 8E - Panel Width = 600mm (23.62 in)

107A to 211A/500-600V Models (size 8E)  
and 100A to 179A/660-690 V Models (size 8E)

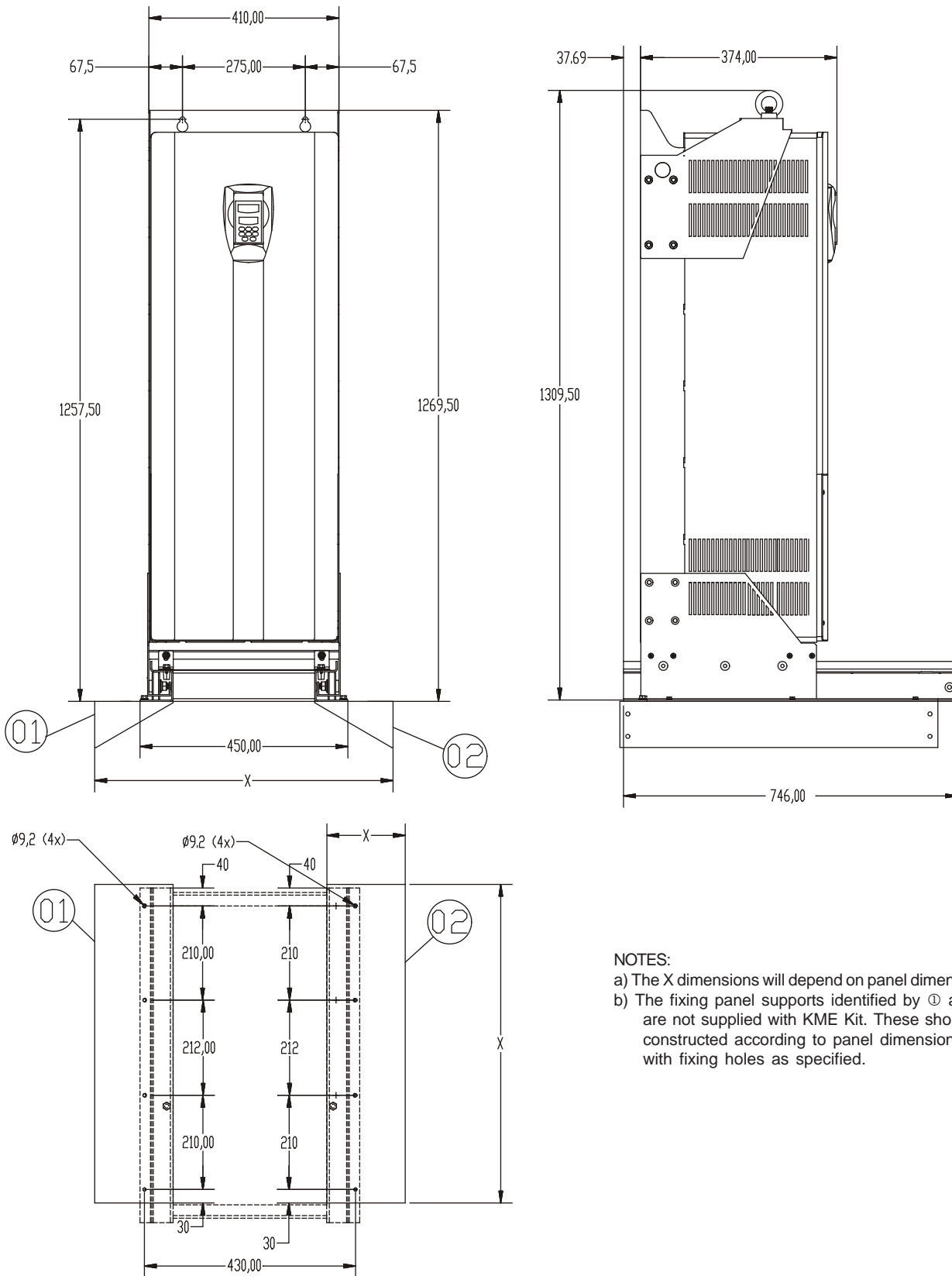

NOTES:

- a) The X dimensions will depend on panel dimensions.
- b) The fixing panel supports identified by ① and ② are not supplied with KME Kit. These should be constructed according to panel dimensions and with fixing holes as specified.

Figure 9.12 d) - KIT-KME for Size 8E - Panel Width = 800mm (31.50 in)

312A to 361A/380-480V (size 9) Models

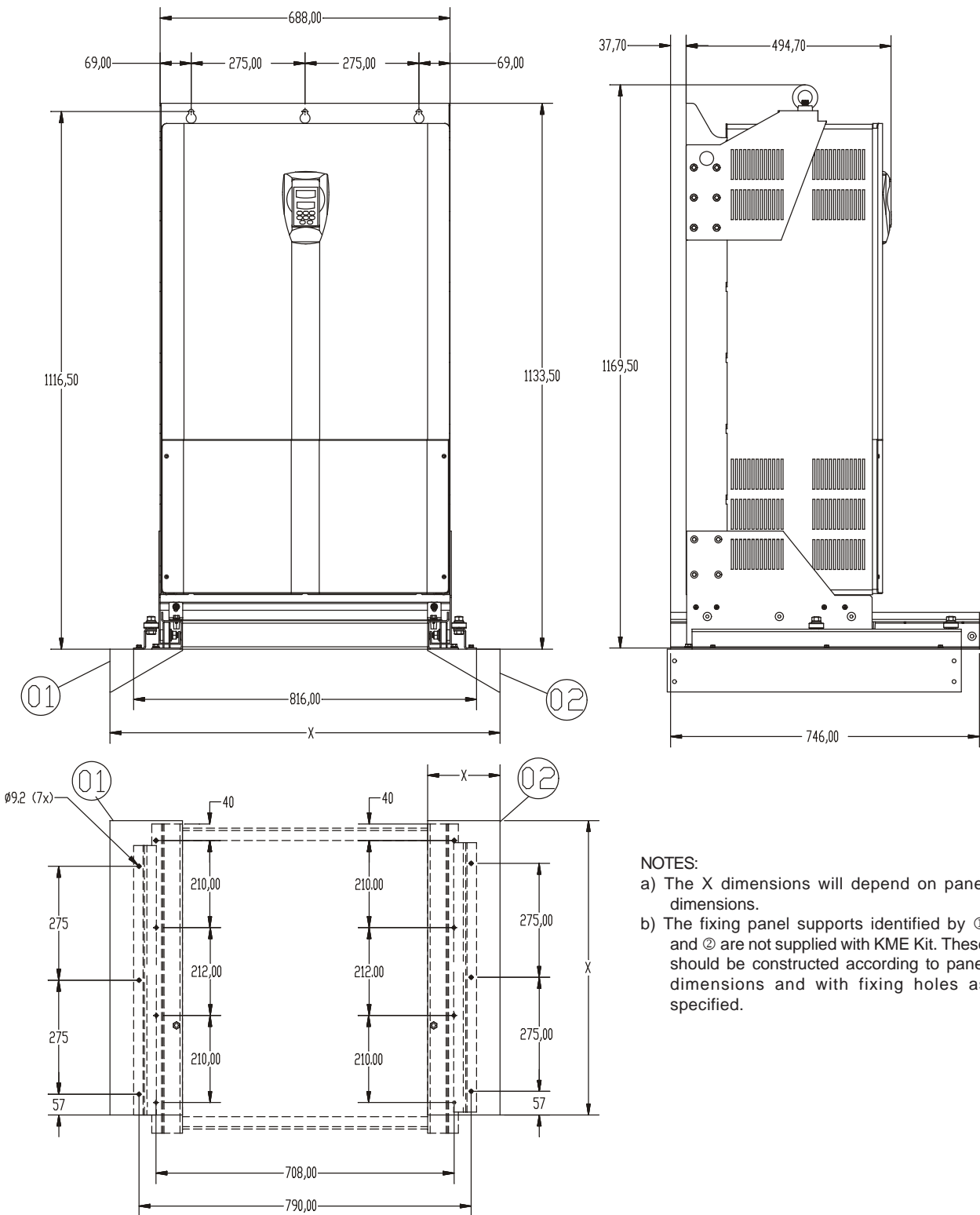

NOTES:

- a) The X dimensions will depend on panel dimensions.
- b) The fixing panel supports identified by ① and ② are not supplied with KME Kit. These should be constructed according to panel dimensions and with fixing holes as specified.

Figure 9.13 a) - KIT-KME for Size 9 - Panel Width = 800mm (31.50 in) and 1000mm (39.37 in)

450A to 600A/380-480V Models (size 10)

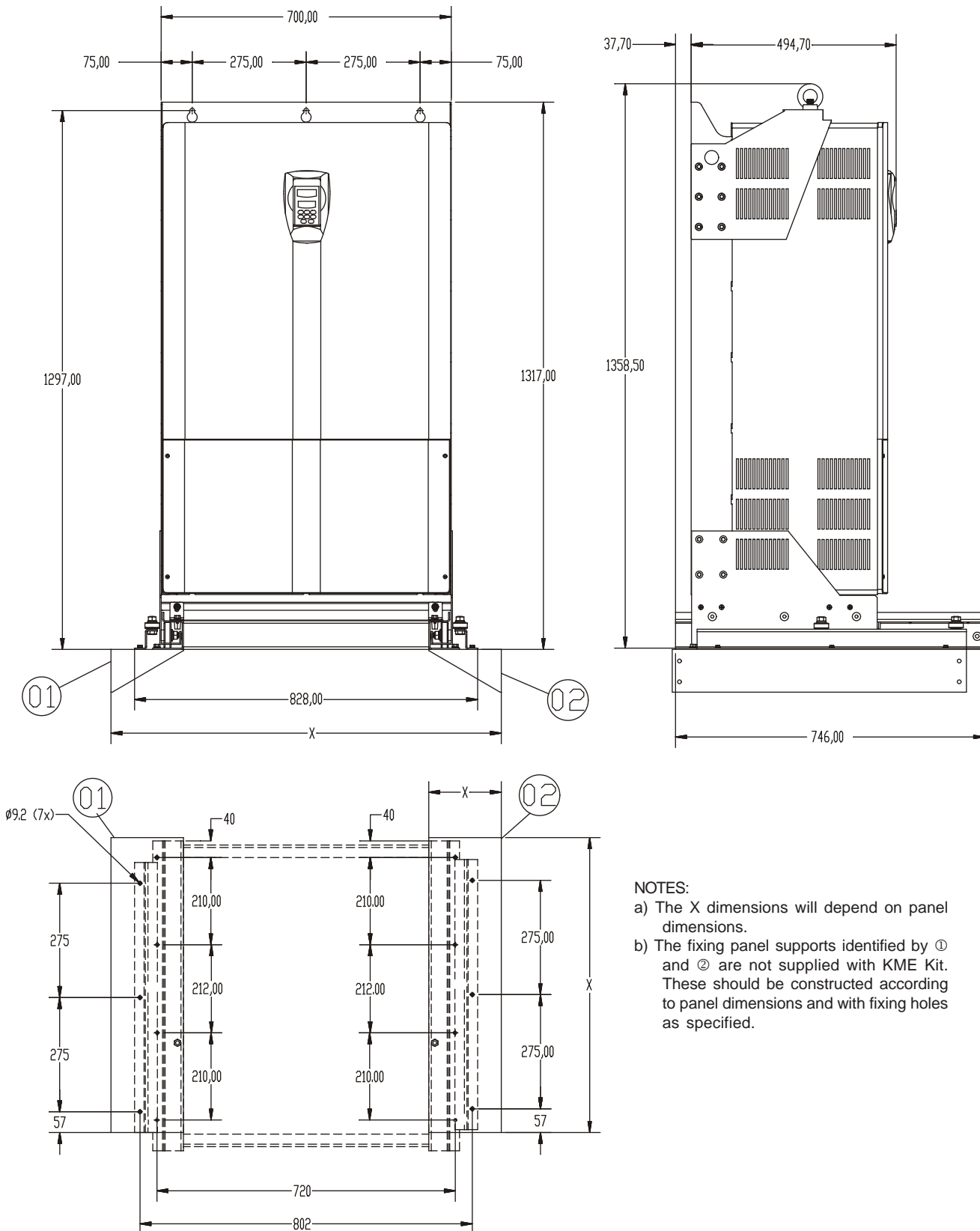

NOTES:

- a) The X dimensions will depend on panel dimensions.
- b) The fixing panel supports identified by ① and ② are not supplied with KME Kit. These should be constructed according to panel dimensions and with fixing holes as specified.

Figure 9.13 b) - KIT-KME for Size 10 - Panel Width = 800mm (31.50 in) and 1000mm (39.37 in)

247A to 472A/500-690V Models (size 10E) and  
225A to 428A/660-690V Models (size 10E)

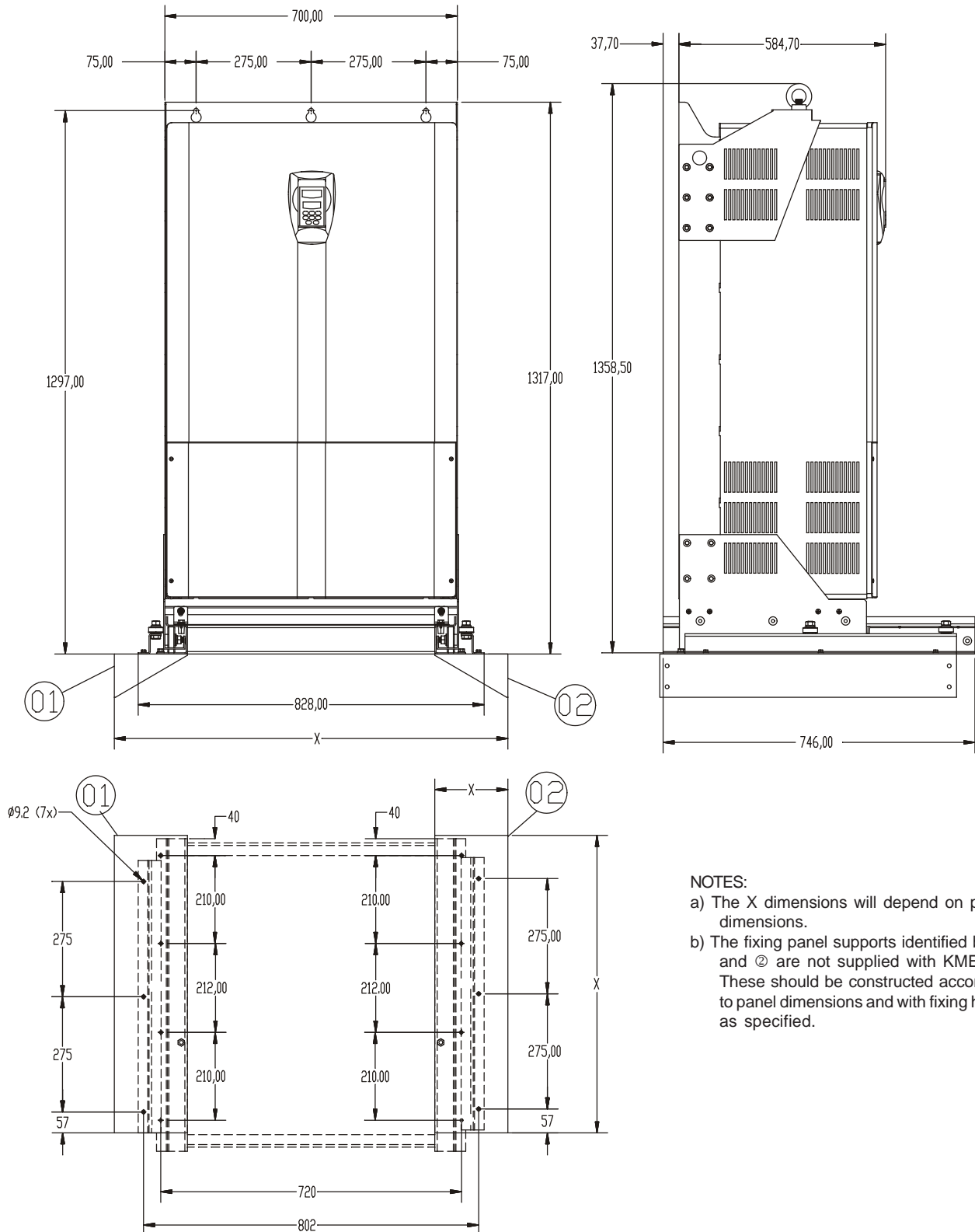

NOTES:

- a) The X dimensions will depend on panel dimensions.
- b) The fixing panel supports identified by ① and ② are not supplied with KME Kit. These should be constructed according to panel dimensions and with fixing holes as specified.

Figure 9.13 c) - KIT-KME for Size 10E - Panel Width = 800mm (31.50 in) and 1000mm (39.37 in)