

# Performance Data

# SP50

Wholesale Products Page: 6260-1

Section: Performance Data

Dated: January 2001

RPM: **1750**

Discharge: **2"**

Solids: **1 1/2"**

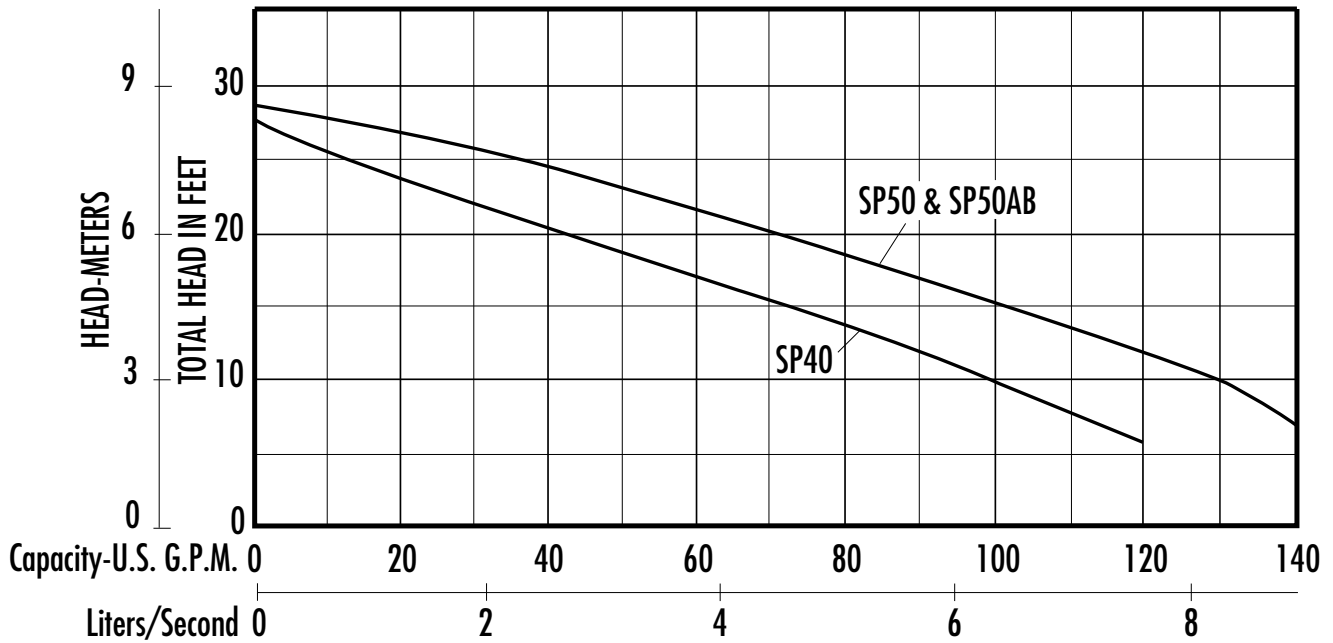
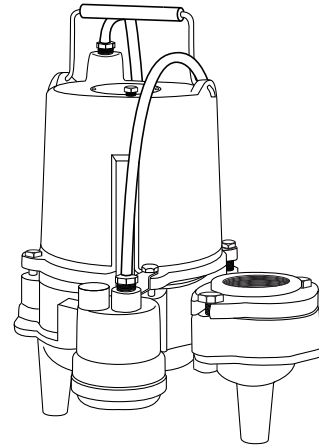

The curves reflect maximum performance characteristics without exceeding full load (Nameplate) horsepower. All pumps have a service factor of 1.2. Operation is recommended in the bounded area with operational point within the curve limit. Performance curves are based on actual tests with clear water at 70° F. and 1280 feet site elevation.

Conditions of Service:

GPM: \_\_\_\_\_ TDH: \_\_\_\_\_



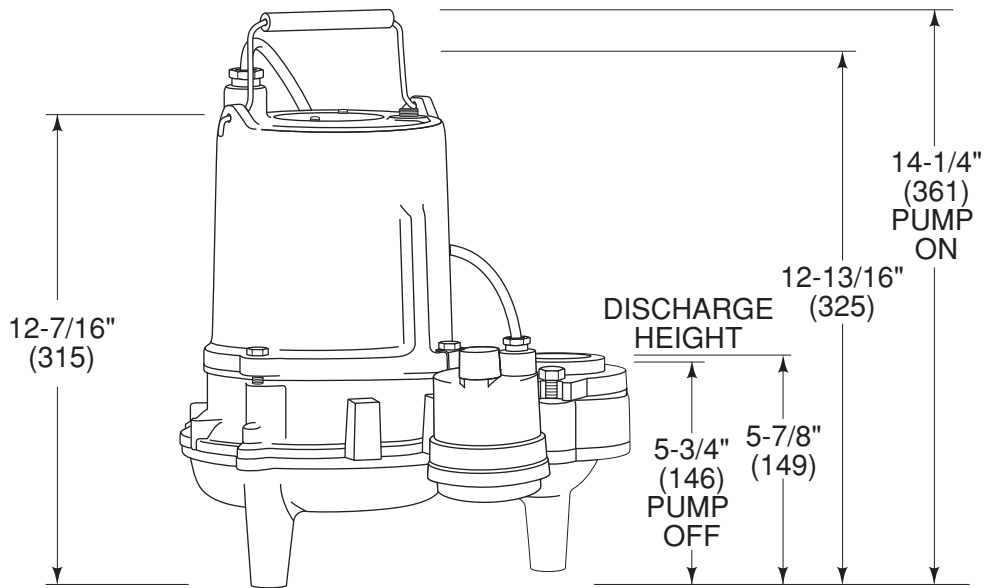
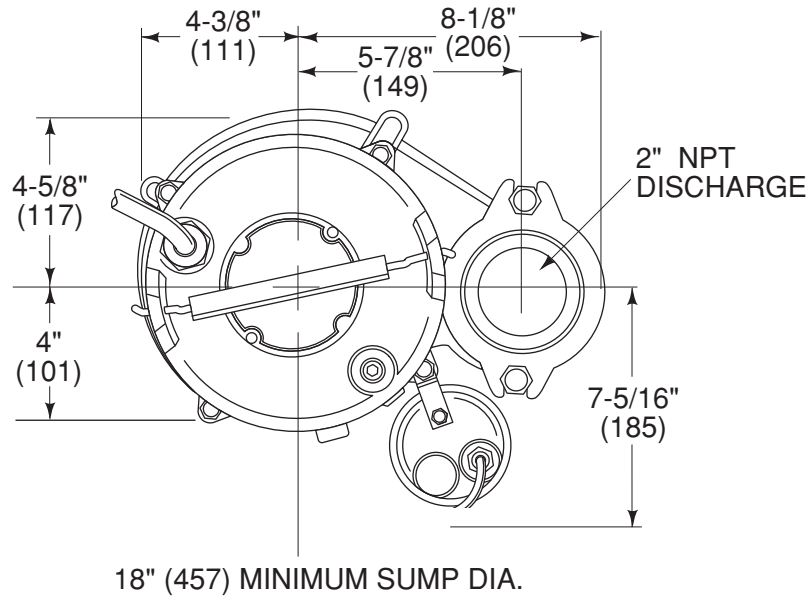

All dimensions in inches. Metric for international use. Component dimensions may vary  $\pm 1/8$  inch. Dimensional data not for construction purpose unless certified. Dimensions and weights are approximate. On/Off level adjustable. We reserve the right to make revisions to our product (s) and the product (s) specifications without notice.

**MODEL: SP50, Sewage Ejector**

<b>R.P.M.</b>	1750
<b>MOTOR TYPE</b>	OIL FILLED WITH AUTOMATIC RESET THERMAL OVERLOAD
<b>GENERAL INSULATION CLASS</b>	A
<b>MOTOR PROTECTION</b>	AUTOMATIC RESET / THERMAL OVERLOAD

HP	VOLTAGE	PHASE	NEC CODE	SERVICE FACTOR	FULL LOAD AMPS
1/2	115	1	-	1	12
1/2	200	1	-	1	6.8
1/2	230	1	-	1	6
1/2	200	3	-	1	4.1
1/2	230	3	-	1	3.5
1/2	460	3	-	1	1.8
1/2	575	3	-	1	1.4

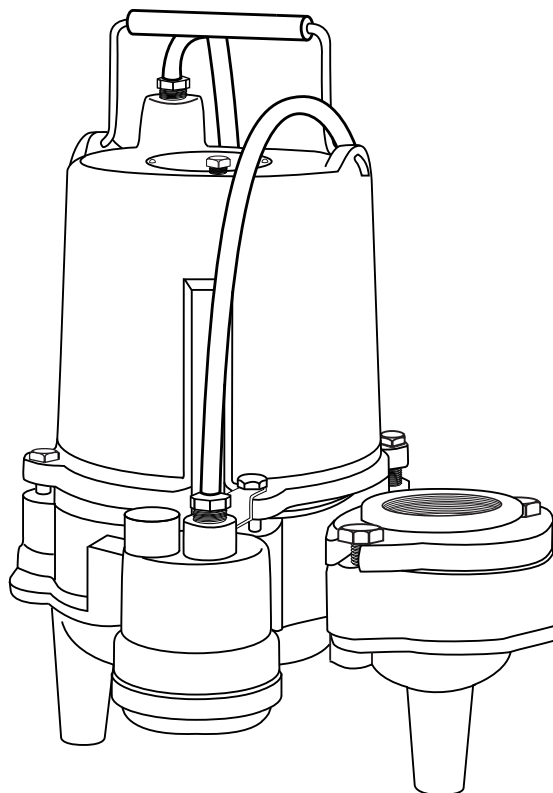

**MODEL: SP50, Sewage Ejector****Physical Data:**

DISCHARGE SIZE	2" NPT(STANDARD) 3" NPT (OPTIONAL)
SOLIDS SIZE	1½"
IMPELLER TYPE	NON CLOG
CABLE LENGTH	10' STANDARD 20' OPTIONAL
PAINT	PAINTED AFTER ASSEMBLY, DARK GREEN, WATER REDUCIBLE ENAMEL, ONE COAT, AIR DRIED.

**Temperature:**

MAXIMUM LIQUID	140°F
MAXIMUM STATOR	
OIL FLASH POINT	

**Technical Data:**

POWER CORD TYPE	STW-A	
MATERIALS OF CONSTRUCTION	MOTOR HOUSING	CAST IRON
	CASING	CAST IRON
	IMPELLER	CAST IRON
	MOTOR SHAFT	NICKEL PLATED STEEL
	HARDWARE	STAINLESS STEEL
	"O" RINGS	BUNA - N
MECHANICAL SEALS Standard:	CARBON / CERAMIC	
UPPER BEARING	SINGLE ROW-BALL	
LOWER BEARING	SINGLE ROW-BALL	

## **SUBMERSIBLE SEWAGE EJECTOR MODEL: SP50**

### **1.01 GENERAL**

Contractor shall furnish all labor, materials, equipment and incidentals required to provide (Qty.) submersible centrifugal sewage ejector pump(s) as specified herein. The pump model covered in this specification is the SP50. The pump furnished for this application shall be MODEL \_\_\_\_\_ as manufactured by Hydromatic Pumps.

### **2.01 DESIGN CONDITIONS**

Each pump shall be rated \_\_\_\_\_ H.P., \_\_\_\_\_ volts, \_\_\_\_\_ phase, \_\_\_\_\_ hertz and operate at \_\_\_\_\_ RPM.

### **3.01 OPERATING CONDITIONS**

The pump shall deliver \_\_\_\_\_ U.S. GPM/LPS at \_\_\_\_\_ feet/meters TDH, and handle a \_\_\_\_\_ inch solid. The curve submitted for approval shall state, in addition to head and capacity performance, solid handling capability, amp rating, and design impeller diameter.

### **4.01 CONSTRUCTION**

Each pump shall be of the sealed submersible type, incorporating features normally found in pumps furnished for the residential market.

These features include:

1. The pump volute, motor, and seal housing shall be high quality gray cast iron, ASTM A-48, Class 30.
2. The pump inlet shall be open and clear, without screening to provide access for sewage and solids.
3. All external mating parts shall be machined and Buna N, O-Ring sealed.
4. All fasteners exposed to the pumped liquid shall be 300 series stainless steel.
5. All power cords shall be water resistant UL or CSA approved, with double insulation, and sized as a function of Amp. draw.

### **5.01 MOTOR AND SHAFT**

The stator, rotor and bearings shall be mounted in a sealed submersible type housing. Single phase motors shall be split phase or capacitor start with centrifugal switch. Three phase motors shall be Polyphase. Full Load and Locked Rotor Amps as well as Start and Run winding resistance shall be tabulated for each pump.

**6.01 BEARINGS, SHAFT AND MECHANICAL SEAL**

An upper radial and lower thrust bearing shall be required. These shall be heavy duty single row ball bearings which are permanently and continuously lubricated and cooled by the dielectric oil which fills the motor housing. The motor shaft shall be nickel plated steel and sealed from the pumped liquid with a carbon ceramic mechanical seal.

**7.01 IMPELLER**

The Impeller shall be high capacity, two vane, non-clog design with pump out vanes on the back side. These vanes wash out grit and stringy material that will damage the shaft and mechanical seal.

**8.01 AUTOMATIC CONTROL**

All single phase pumps should be capable of automatic operation.

**9.01 PRESSURE SWITCH**

The Single Phase SP50 pump is furnished with a pressure diaphragm switch that features a piggy-back plug that allows the pump to be operated manually without removal from the sump.

**10.01 PAINTING**

All cast iron parts shall be painted before assembly with a water reducible alkyd air dried enamel. The paint shall be applied in one coat with a minimum thickness of 3 to 4 mils.

**11.01 TESTING**

All pumps shall be individually tested to include the following:

1. The pump and power cord shall be visually inspected for imperfections, cuts or nicks.
2. The pump shall have a ground continuity check and the motor chamber shall be Hi-potted to test for moisture content and/or insulation defects.
3. The motor and volute housing shall be pressurized and a 10 second air leak decay test run.
4. Oil is added, and the pump is run. Voltage and current are monitored visually, electronically, and the tester listens for any noise or malfunction.