

Product information presented here reflects conditions at time of publication. Consult factory regarding discrepancies or inconsistencies.



PUMP COMPANY

Zoeller Family of Water Solutions™

MAIL TO: P.O. BOX 16347 • Louisville, KY 40256-0347
 SHIP TO: 3649 Cane Run Road • Louisville, KY 40211-1961
 (502) 778-2731 • 1 (800) 928-PUMP • FAX (502) 774-3624

visit our web site:
www.zoeller.com

REPLACEMENT PARTS LIST FOR MODELS: M267 AUTOMATIC 115V D267 AUTOMATIC 230V N267 NONAUTOMATIC 115V E267 NONAUTOMATIC 230V WM267 AUTOMATIC w/wired float switch 115V

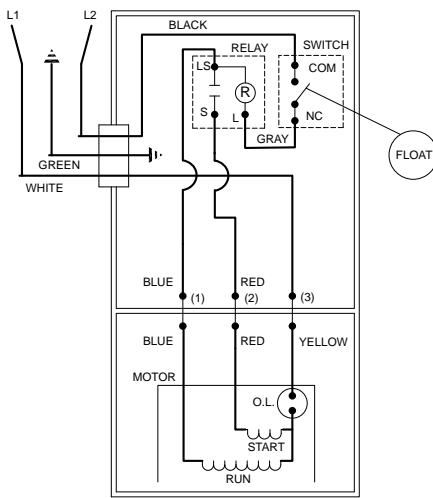

002389

WIRING DIAGRAM FOR MODELS
 "M267-A", "M267-B", "M267-C", "M267-D",
 "D267-A", "D267-B", "D267-C", "D267-D"
 4/79 (PI) thru 8/86 (US)

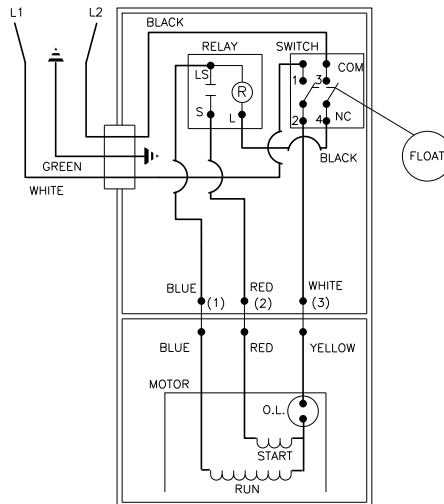

004620

WIRING DIAGRAM FOR MODELS
 "M267-E", "M267-F"
 "D267-E", "D267-F"
 9/86 (VS) thru Current

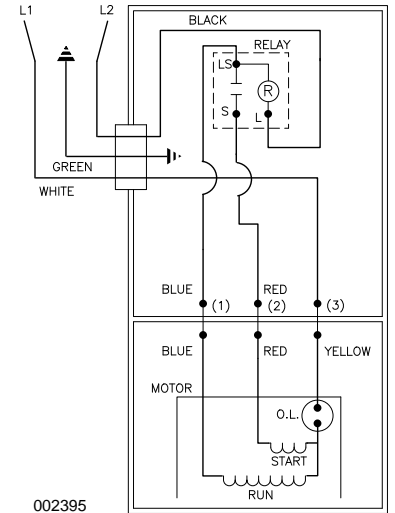

002395

WIRING DIAGRAM FOR MODELS
 "N267-A", "N267-B", "N267-C",
 "N267-D", "N267-E", "N267-F"
 "E267-A", "E267-B", "E267-C",
 "E267-D", "E267-E", "E267-F"
 4/79 (PI) thru Current

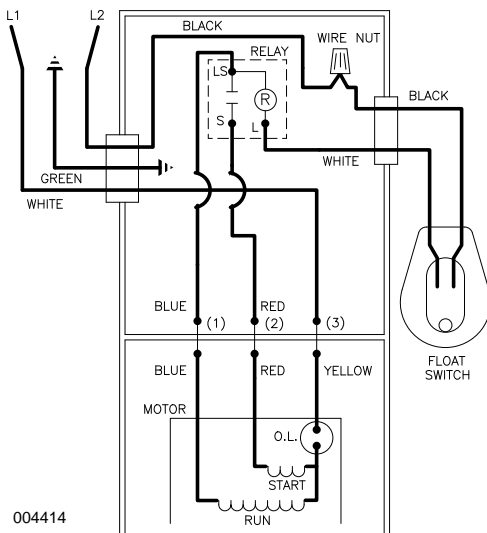

004414

WIRING DIAGRAM FOR MODELS
 "WM267-B", "WM267-C", "WM266-D"
 12/86 (YR) thru Current

TO ORDER REPLACEMENT PARTS:

PLEASE FURNISH THE FOLLOWING INFORMATION:

- Model Number.
- Part Number of Pump.
 (If manufactured prior to June 1988, give 2 letter date code following Model No.)
- Part Number and Description of part.

REPLACEMENT PARTS ILLUSTRATION FOR MODELS "M267" AND "D267"

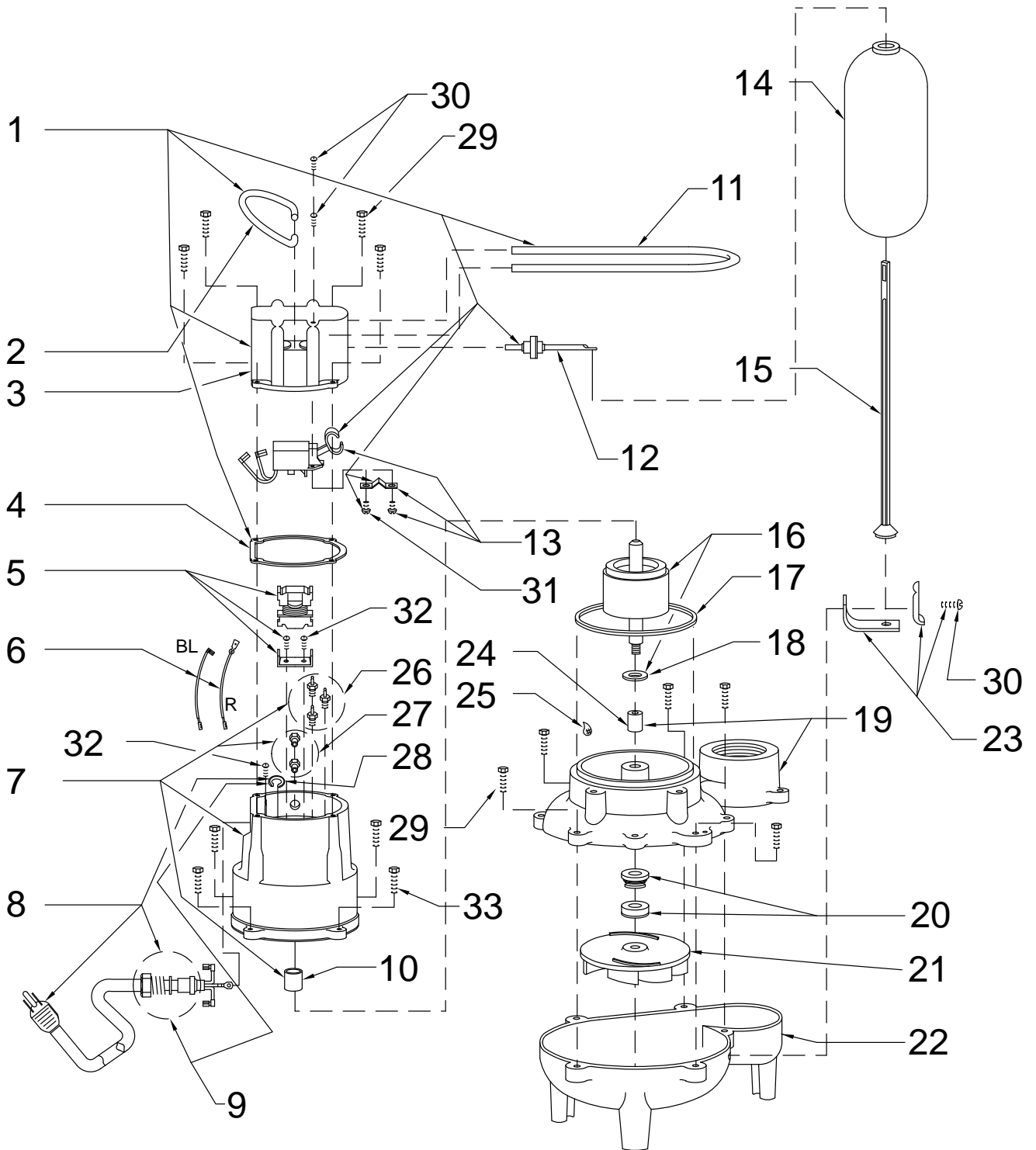

SK132

REPLACEMENT PARTS ILLUSTRATION FOR MODEL "N267" AND "E267"

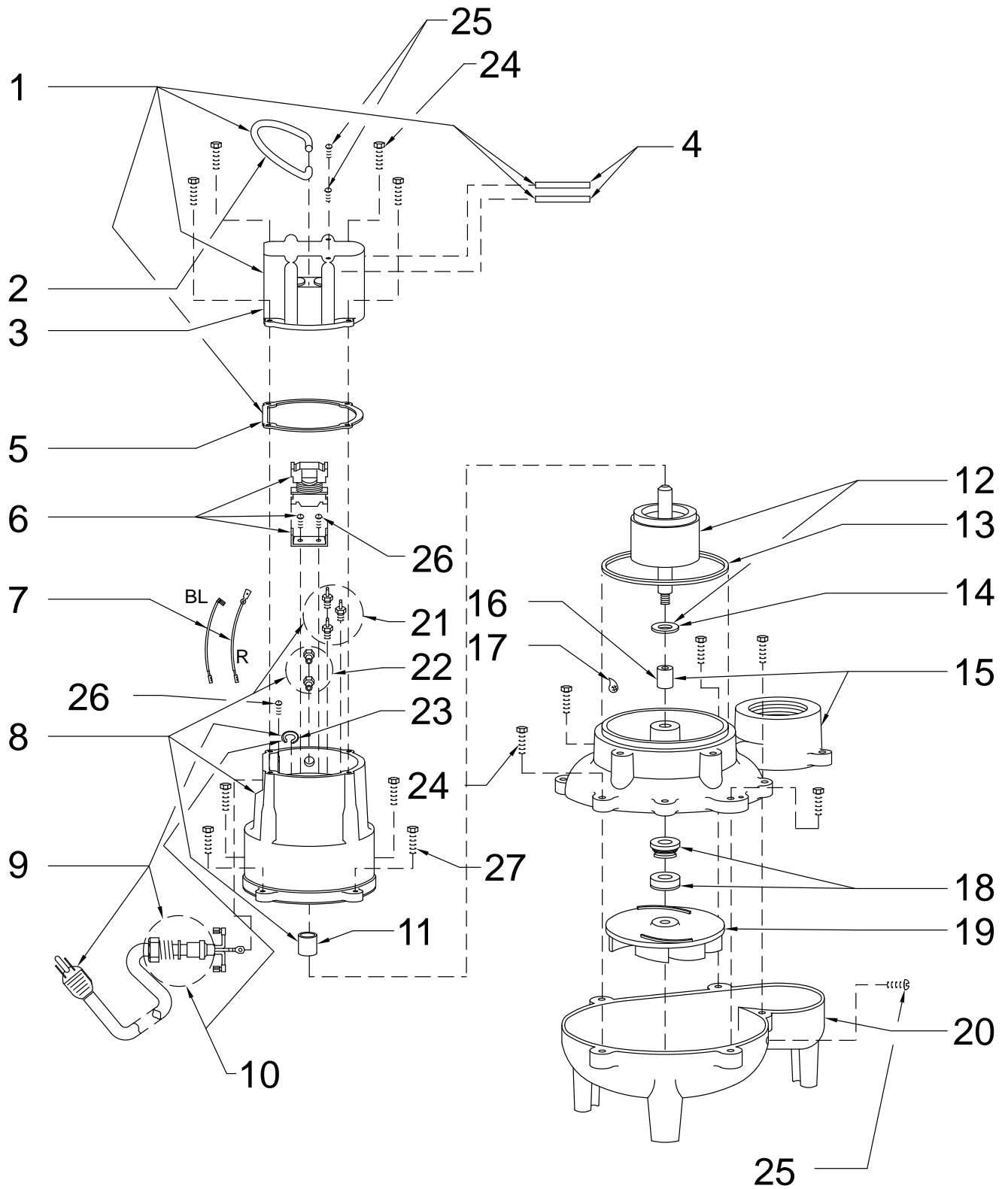

REPLACEMENT PARTS LIST FOR MODELS "WM267"

See page 7 for "WM267" illustration.

REF. NO.	DESCRIPTION	QTY	NOTES	MODELS: WM267-B WM267-C WM267-D		
				12/86 YR thru 9/92	10/92 thru 9/94	10/94 thru Current
1	Cover & Handle Asm	1		267051	267051	267051
2	• Handle	1		267032	267032	267032
3	Cover, Mach	1		267052	267052	267052
4	Retainer, Hdl-Na	1		267053	267053	267053
5	• Gasket, Case/Cover	1		267007	267007	267007
6	Relay Asm 115V/G5	1		002474	002474	002474
7	• Wire Pkg (2) Wires	1		267014	267014	267014
8	Housing, Mtr & Str 115V/1Ph GE	1	1,2	004672	004672	004672
	Housing, Mtr & Str 115V/1Ph EMD	1	1,2	005580	005580	005580
9	Cord Term & Seal	1	3	006090	006090	006090
10	• Seal, Cord-Asm & Strain Relief	1		094032	094032	094032
11	Bearing, Upper	1		NA	NA	NA
12	Rotor Asm 115/230V/1Ph GE	1	2	267005	267005	267005
	Rotor Asm 115/230V/1Ph EMD	1	2	004021	004021	004021
13	• Seal, Mtr Hsg	1		267006	267006	267006
14	• Washer, Trst-Nyl. 875X.504X.050"	1		002140	002140	002140
15	Housing, Pump-Mach	1		004404	004404	003877
16	Bearing, Sleeve-Lower Rotor	1		NA	NA	NA
17	• Oil, Dielectric (24.5 Oz)	1		267056	267056	267056
18	• Seal Asm, Shaft	1		267027	267027	267027
19	Impeller "267"	1		003884	003884	150857
20	Base, Mach "267"	1		003879	003879	008646
21	• Seal, Thru Wall Term	3		003402	003402	003402
22	• Plug, Test-White	2		034090	034090	034090
23	• Clamp, Strain Relief	1		001770	001770	001770
24	Switch, Mf-Asm "WM267 PF & QJ"	1		004485	004485	009631
25	Seal, Cord-Asm "WM267 PF & QJ"	1		004486	004486	004486
26	Connector, Wirenut	2		001776	001776	001776
27	Clamp, Cable-Nylon	1		004413	004413	NA
28	• Screw, .25-20 X .75 HHm-SS	9		001916	001916	001916
29	• Screw, #10-24 X.375 RHM-SI SS	3		001883	001883	001883
30	• Screw, #6-32x.25RHM SI Tc Stlgr	3		001877	001877	001877
31	Switch, MF-ASM w/Float	1		009630	009630	009630
32	Float Rod Retaining Pin	1		NA	NA	009121
33	Rod, Float	1		NA	NA	009118
34	Float Rod Stop	2		NA	NA	009120
35	Float, Mech Switch	1		NA	NA	009119
36	Bracket, Switch Mtg.	1		NA	NA	009117
37	Grommet, Guide	1		NA	NA	003052
38	Screw, #8-32 X .625"	2		NA	NA	009111
39	Clamp, #40HS Worm-SS	1		NA	NA	004304
40	• Screw, ¼-20x.875 HH SS	4		012491	012491	012491
▣	Rebuild Kit			004743	004743	004743

• Items included in Rebuild Kit.

▣ Not shown in illustration.

NOTES:

- 1) Mtr. Hsg., Brg., Stator & Term (Item 8) are preassembled at the factory and must be replaced as a unit. Stator is permanently attached to the Motor Housing. Plug (Item 22) and Seal, Thru Wall Term. (Item 21) are replaceable.
- 2) When ordering Motor Housing, Bearing, Stator and Term. (Item 8) or Rotor (Item 12) specify either GE or Emerson motor. GE motor can be identified by (4) half oval slots spaced at 90° around the outside diameter of the stator. Emerson motor can be identified by (2) half oval slots spaced at 180° around the outside diameter of the stator.
- 3) If an "X" follows Model No., or Date Mfg. on brass ID tag, consult factory for ordering any parts.
- 4) See FM0160 Parts Price Sheet for listing of parts prices.
- 5) "NA" indicates, not applicable.

REPLACEMENT PARTS ILLUSTRATION FOR MODELS "WM267"

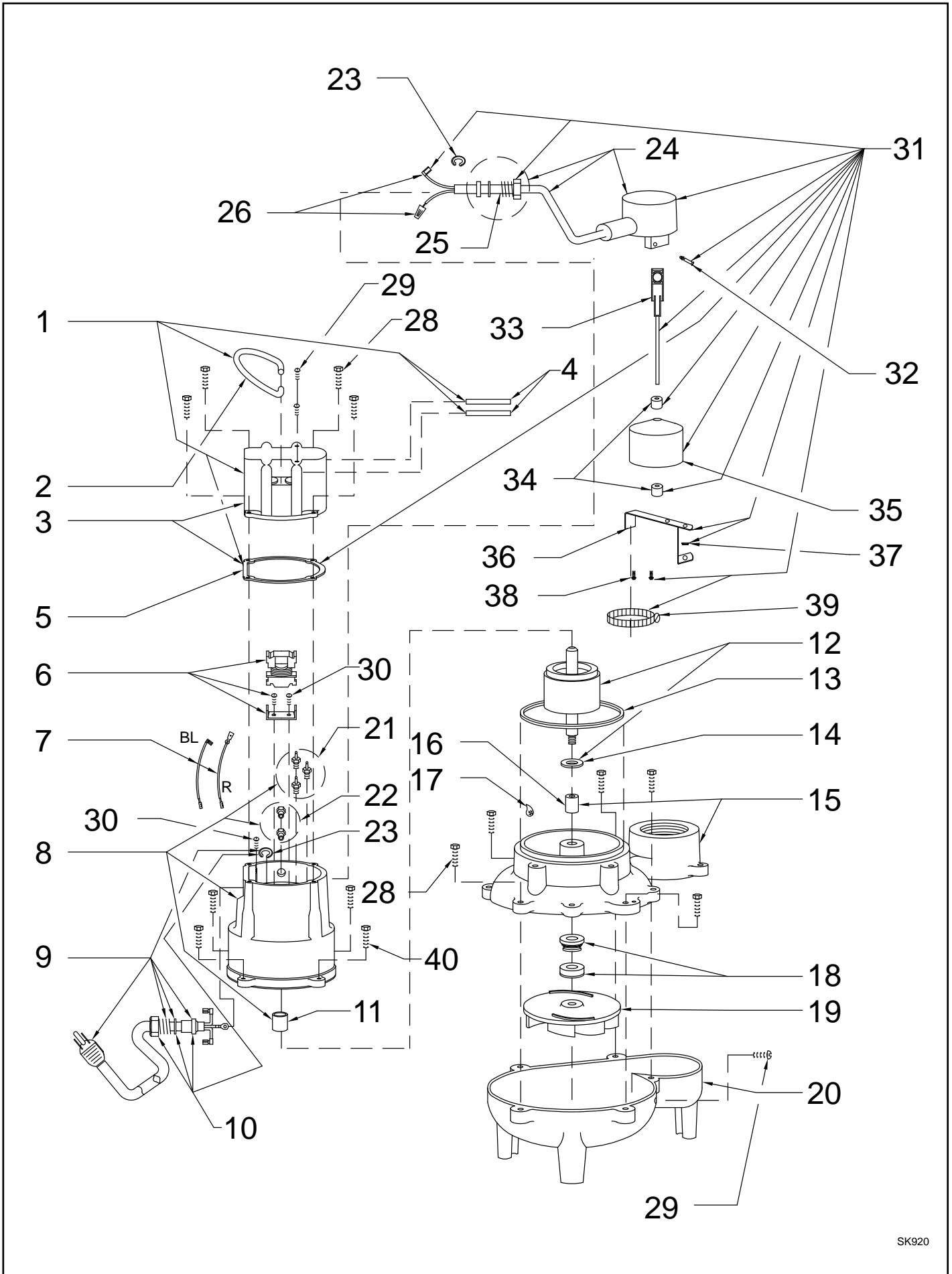

SK920

NOTES



PUMP COMPANY

*MAIL TO: P.O. BOX 16347 • Louisville, KY 40256-0347
SHIP TO: 3649 Cane Run Road • Louisville, KY 40211-1961
(502) 778-2731 • 1 (800) 928-PUMP • FAX (502) 774-3624*

Your Peace of Mind is Our Top Priority™

**visit our web site:
www.zoeller.com**

© Copyright 2011 Zoeller Co. All rights reserved.