

Domestic Water Supply Family



Handbook

Applications Page No.

- Constant pressure 5
- Flow based pressure boosting 5
- Suction lift 6
- Rainwater harvesting 6

Pump Selections

- EZ Boost 6
- MQ 6
- Basic Line Jets 6

Accessories

- Pressure Tanks 7
- Pressure Switches 7
- Valves 7
 - Check 7
 - Foot 7
 - Shut-off 7
 - Flow Control 7
 - Pressure Reducing 7
 - Pressure Relief 7

Theory

- Matching consumption and pump capacity 7
- Pump selection 7
- Piping 7

Trouble Shooting

- Suction lift 8
- Flooded suction 8
- Pressure Tanks 9
- WebCAPS 9

Product Guides

- EZBoost 12
- MQ 28
- Basic Line Jets 38

Submittal Data Sheet 57



Domestic Water Supply Handbook



BE > THINK > INNOVATE >

GRUNDFOS 





Handbook

Notes



Constant Pressure System:

In constant water pressure systems, only the required discharge pressure needs setting. Cut-in / out pressures do not play a role in this system.

In Grundfos's BMQE constant water pressure system (EZ Boost), this is done by a simple touch of a button on the accompanying CU 301 control unit. Discharge pressure can be set from 40 to 100PSI, according to individual needs and piping system limitations.

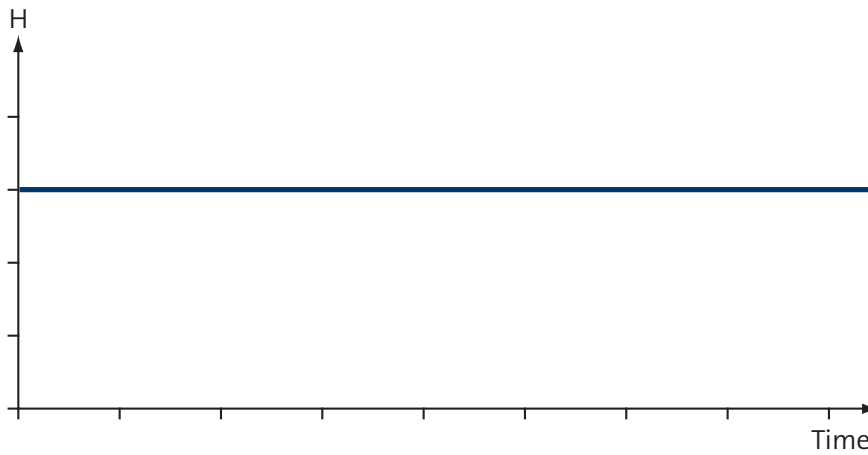

Pressure does not vary in relationship to consumption

Flow Based Pressure Boosting:

The pump starts automatically when water is consumed and stops automatically when the consumption ceases. This is accomplished by a flow switch connected to a printed circuit board (PCB). The flow switch is closed when water is consumed and the signal sent to the PCB starts the pump. The flow switch is opened when the consumption ceases and the signal sent to the PCB stops the pump.

The pump will produce pressure in relation to the flow rate with any incoming pressure cumulative to the total discharge pressure.

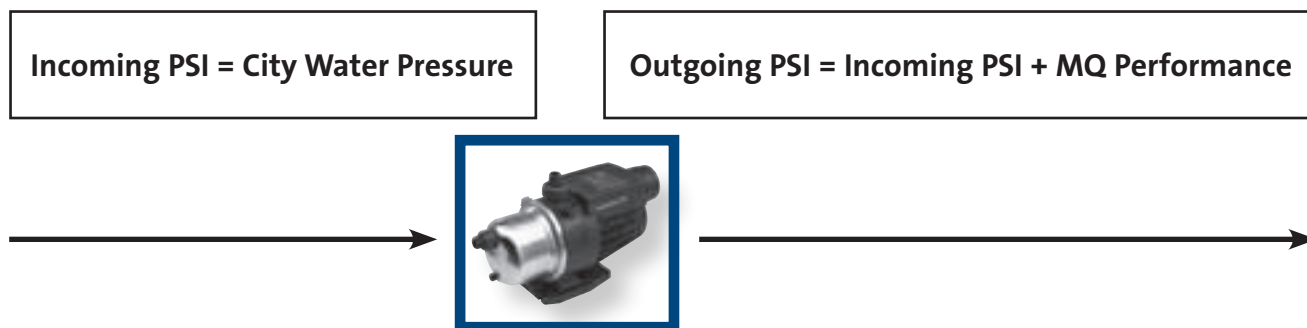

Suction Lift:

High pressure water from the drive pipe passes through the venturi and pulls water from the well into the ejector, and then pushes it up to the pump. This allows us to push water up to the pump from depths greater than 25 feet, or to boost the output from a shallow well pump to higher pressures.

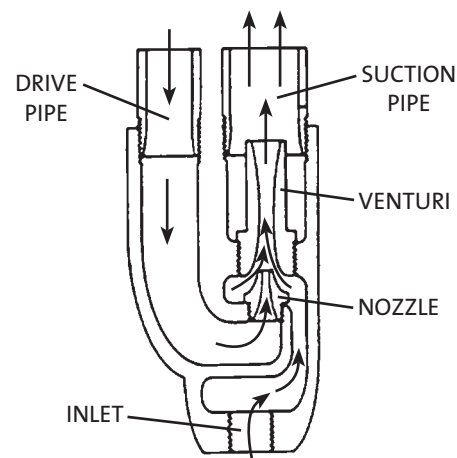
**Rain Water Harvesting:**

Reduce, reuse, and recycle. The Three R's of conservation. Rain water harvesting is the way to store rain water for future use such as the watering of a garden. Simply collect rain water from the roof of your home through the eaves into a storage container. Use the MQ to pull a suction lift, using a non collapsible suction line, from the storage container to water your garden.

Pump Selections:**EZ Boost: Constant Pressure at the touch of a button.**

The EZ Boost uses the time tested technology used in the SQE constant pressure system (submersible application). The MSE 3 motors are based on solid state electronics and permanent magnet rotors which account for high motor efficiencies. Variable speed is offered though frequency control via the CU301 remote status box. The System can be set to operate at any duty point in the range between minimum and maximum performance of the pump. The EZ Boost has built in safeties in the solid state electronics. The small footprint of the pump allows the system to be positioned either vertically or horizontally depending on the needs of the application. Refer to the EZ Boost installation video on our web site www.grundfos.us

MQ: Maximum Quality Flow Based Pressure Boosting System:

The MQ is a complete, all-in-one unit, incorporating pump, motor, diaphragm tank, pressure and flow sensor, controller and check valve. Built in safeties ensure long life of the pump. These safeties include: dry running; excessive temperature; any overload conditions. The MQ is a self priming pump and needs no priming other than that at installation. The MQ is a plug-n-play system.

Basic Line: Durable and dependable Basic Line Jets.

Grundfos offers shallow well, deep well, and convertible jet pumps. Our jets are self-priming centrifugal pumps suitable for domestic water supply, light agriculture, and industrial water transfer applications. Three models include: JPS; JPF; JDF. The JPS are shallow well jets with built-in ejectors. The JPF are convertible jets with detachable ejector assembly for deep well applications. The JDF are deep well jets with separate deep well port for connection to Deep Well ejector kits.

Pressure Tanks:

Tanks are provided with the EZ Boost and MQ systems. The EZ Boost has an external tank and the MQ an internal tank. The Basic Line however may need a tank depending on your application. In order to minimize the number of pump starts and stops in the water supply system, and to reduce problems with water hammer in the pipe work, a pressure tank should be installed.

Pressure Switches:

Pressure switches are used to control pump operation. These switches have a cut-in pressure and a cut-out pressure to turn the pump on and off respectfully. The EZ Boost comes with a pressure transducer for constant pressure. The MQ has a built-in pressure switch. Basic Line Jets have the pressure switch attached.

Valves:

Check valves: The EZ Boost and MQ systems have built-in check valves. When doing a suction lift with the MQ a check valve is required at the inlet. This check valve is provided with every MQ.

Foot Valves: When pulling a suction lift (shallow or deep well) with the Basic Line a foot valve is required. This valve is installed at the end of the suction pipe to prevent back flow. The MQ will also benefit from the use of a foot valve when doing suction lifts.

Shut off valves: Use shut off valves in the piping system in such a way to make it possible to drain only the part of the system that needs attention or repair.

Flow control valves: Used in applications where a set amount of flow (gallons per minute) are required. An example of this would be a shower head or an irrigation system.

Pressure reducing valves: Used in applications where the incoming water pressure exceeds the maximum inlet pressure of the pump as is the case with the MQ and city water pressure. The Pressure Reducing Valve or PRV is used inline after the city water tap and before the pump to ensure a set pressure.

Pressure relief valves: This valve is a spring controlled device that can be adjusted to meet the needs of the pumping system. Used in applications where high pressure can result in damage to accessories such as tanks where there are maximum pressure ratings.

Theory:

Matching consumption and pump capacity:

Selecting the right pump is a matter of matching water consumption with pump capacity. Installing an under or oversized pump should be avoided. Consumption varies greatly depending on housing standards and lifestyle. Garden watering in the summer can increase consumption.

Pump Selection:

Pump selection is based on the water demand and the system head. The water demand depends on the number of consumers connected to the system. Head can either be expressed in feet or PSI. Head refers to static head, pressure head, and friction head. For assistance in Pump Selection refer to the WebCAPS selection program found on the Grundfos web site.

Piping:

In any water supply system, the sizing and choice of materials of the pipe work has an impact on the choice of pumps and on the cost. Piping takes into account the system head as referred to in Pump Selection. Static head is the distance from the ground water level to the uppermost tap. Pressure head is the system pressure the customer wants to achieve. In most residential application this pressure is approximately 60PSI. Friction head depends on the pipe size, type and length. When calculating friction loss always remember to allow for deterioration in the piping schematic as all water pipes will eventually become coated with rust, lime deposits, etc. Flow velocity in the piping must be kept low as noise can occur due to turbulence in elbows and valves or from water hammer. Fitting a pressure relief valve in the discharge piping is recommended to protect the piping from over-pressure due to system malfunction.

Troubleshooting:

Suction Lift:

When installing above ground suction lift pumps, the following basic rules must be adhered to:

- Avoid frost.
- Pump only clean water.
- Install a filter if water contains impurities.
- A foot-valve must be installed.
- The suction pipe must be 100% air tight.
- The pump must be primed before starting for the first time.

Fault	Cause	Remedy
1. The pump is running but there is no pressure.	a) The pump and suction pipe need to be primed.	Fill the pump and pipe with water.
	b) The suction pipe is not 100% tight.	Check all connections and the suction pipe. Replace if necessary.
2. The pump does not stop.	a) The pressure switch is set incorrectly.	Check the setting and adjust accordingly
3. The pump does not deliver enough water.	a) Lack of water in the well.	Drill new well.
	b) Suction pipe is not 100% tight.	Check all connections and the suction pipe. Replace if necessary.
	c) Pipe system is blocked.	Clean pipework.
	d) Pump capacity is not sufficient	Replace with a larger capacity pump
4. Pump switches on and off frequently.	a) Pre-pressure in pressure tank is too low or too high.	Adjust pre-pressure in pressure tank. (0,9 x cut-in pressure)
	b) Faulty footvalve.	Check footvalve, replace if necessary.
	c) The pressure switch differential between the start and stop pressures is too small.	Increase the differential.

Flooded Suction:

When installing above ground suction booster pumps, the following basic rules must be adhered to:

- Inlet pressure.
- Avoid frost.
- Pump only clean water.
- Avoid dry-running
- A non-return valve must be installed.
- The suction pipe must be 100% air tight.
- The pump and piping must be primed before starting for the first time.

Fault	Cause	Remedy
5. The pump is running but there is no pressure.	a) The pump and/or suction pipe is incorrectly primed.	Prime the pump and/or suction pipe with water.
	b) The non-return valve or suction pipe is leaky.	Replace the non-return valve and/or seal the suction pipe.
6. The pump does not deliver enough water.	a) The suction lift is too high.	Check the distance from the pump to the water level in the well. If possible, mount the pump nearer the water level.
	b) Pressure switch settings are incorrect	Adjust settings accordingly
7. The pump has run for a long time, but delivers no water when restarted after a standstill.	a) The pump and/or suction pipe is emptied of water.	Prime the pump and/or suction pipe with water.
8. Pump switches on and off frequently.	a) Pre pressure in pressure tank is too low or too high.	Adjust pre-pressure in pressure tank. (0,9 x cut-in pressure)
	b) Faulty foot valve.	Check footvalve, replace if necessary.
	c) The pressure switch differential between the start and stop pressures is too small.	Increase the differential.

Pressure Tanks:

Keep the following tips in mind, when dealing with installations using pressure tanks:

- Stop the pump and open a valve to relieve the water pressure before checking the pre-charge pressure of the tank.
- For traditional on/off controlled pumps, the pre-charge pressure should equal the cut-in pressure multiplied by 0.9.

Installation note:

You should always consult the Instruction and Operation manual for each specific pump during installation and start.

WebCAPS:

Find detailed information via the Grundfos website. WebCAPS is an easy to use on-line tool that enables users to size systems and access general information about our products, where you can easily download the most up-to-date pump information.





EZ Boost™ System with BMQE Booster Pump, Tank, Pressure Sensor, and Controller



Product Guide	Page No.
General data	13
Product range	14
Materials of construction	15
Type key	15
15 BMQE performance curves	16
22 BMQE performance curves	17
30 BMQE performance curves	18
Dimensions, weights and electrical data	19
Dimensional sketch	19
Technical data - BMQE pump	20
Technical data - EZ Boost controller	21
Accessories	22
EZBoost Quick Guide	23
EZBoost System Diagram	23
EZBoost Pre-Installation	24
Parallel Operation	25

EZ BOOST SYSTEM

Introduction

There are many applications within water supply where it is necessary to increase the system pressure. The Grundfos EZ Boost system is the optimum solution for applications requiring:

- Sealless pumps
- Quiet operation and/or
- Maintenance-free operation.

The EZ Boost system offers the following features:

- Dry-running protection
- High efficiency of pump and motor
- Excellent wear resistance
- Soft starter
- Over voltage and under voltage protection
- Overload protection
- Over temperature protection.
- Variable speed
- Electronic control and communication.

Applications

- Pressure boosting.
- Water treatment.

Pumped liquids

Thin, non-explosive liquids not containing abrasive particles or fibers. The liquid must not be able to attack the pump materials chemically or mechanically.

Should the density and/or viscosity of the pumped liquid exceed the density and/or viscosity of water, please contact Grundfos.

BMQE Pump

The pumps used for The Grundfos EZ Boost system are modified SQE submersible pumps. The EZ Boost BMQE pump is an SQE pump with an MSE 3 motor. Pump and motor are centered in the 4" stainless steel sleeve.

BMQE pumps are suitable for both continuous and intermittent operation for a variety of pressure boosting applications.

BMQE Motor

The MSE 3 motors are based on state-of-the-art technology within permanent magnets (PM motor), which accounts for the high motor efficiencies. In addition, the motors have a built-in electronic unit with a frequency converter for variable frequency and soft starting.

The MSE 3 motors features high efficiency within a wide load range. The high and flat efficiency curve of the PM motor enables the same motor to cover a wide power range as opposed to conventional AC motors. For BMQE pumps, this means fewer motor variants.

EZ Boost Controller

The BMQE pump features variable speed which is offered through frequency control via the EZ Boost controller. As a consequence, the pump can be set to operate in any duty point in the range between the minimum and maximum performance curves of the pump. Each BMQE pump must be connected to its own EZ Boost controller.

It is also possible to operate the BMQE without an EZ Boost controller, though the features offered will be fewer.

BMQE Pump Sectional Drawing

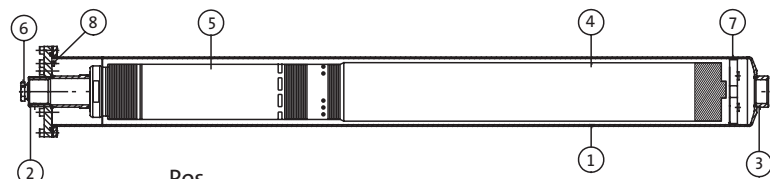

Pos.

- | | |
|-------------------------|---------------------|
| 1. Sleeve | 5. SQE pump |
| 2. Discharge connection | 6. Cable entry |
| 3. Suction connection | 7. Centering device |
| 4. MSE 3 motor | 8. Air vent screw |

Operating conditions

- Flow: Max. 39 US GPM (8.9 m3/h)
- Head: Max. 300 ft (91.4 m)
- Temperature: Max. 95°F (35°C)
- Operating pressure: Max. 347 PSI (23 bar)
- Inlet pressure: Min. 8 PSI (0.55 bar)
- Sound-pressure level: The sound pressure level of the BMQE is lower than 74 db[A] at a distance of 3 feet (1 meter).

It is recommended by Grundfos that the pump be installed with sound and vibration dampening equipment such as flexible piping adapters and anti-vibration mounting. The pump should not be mounted in or adjacent to living quarters. The pump can also be wrapped with sound-proofing insulation to reduce noise (see page 16, EZ Boost System Diagram).

Performance range, 60 Hz

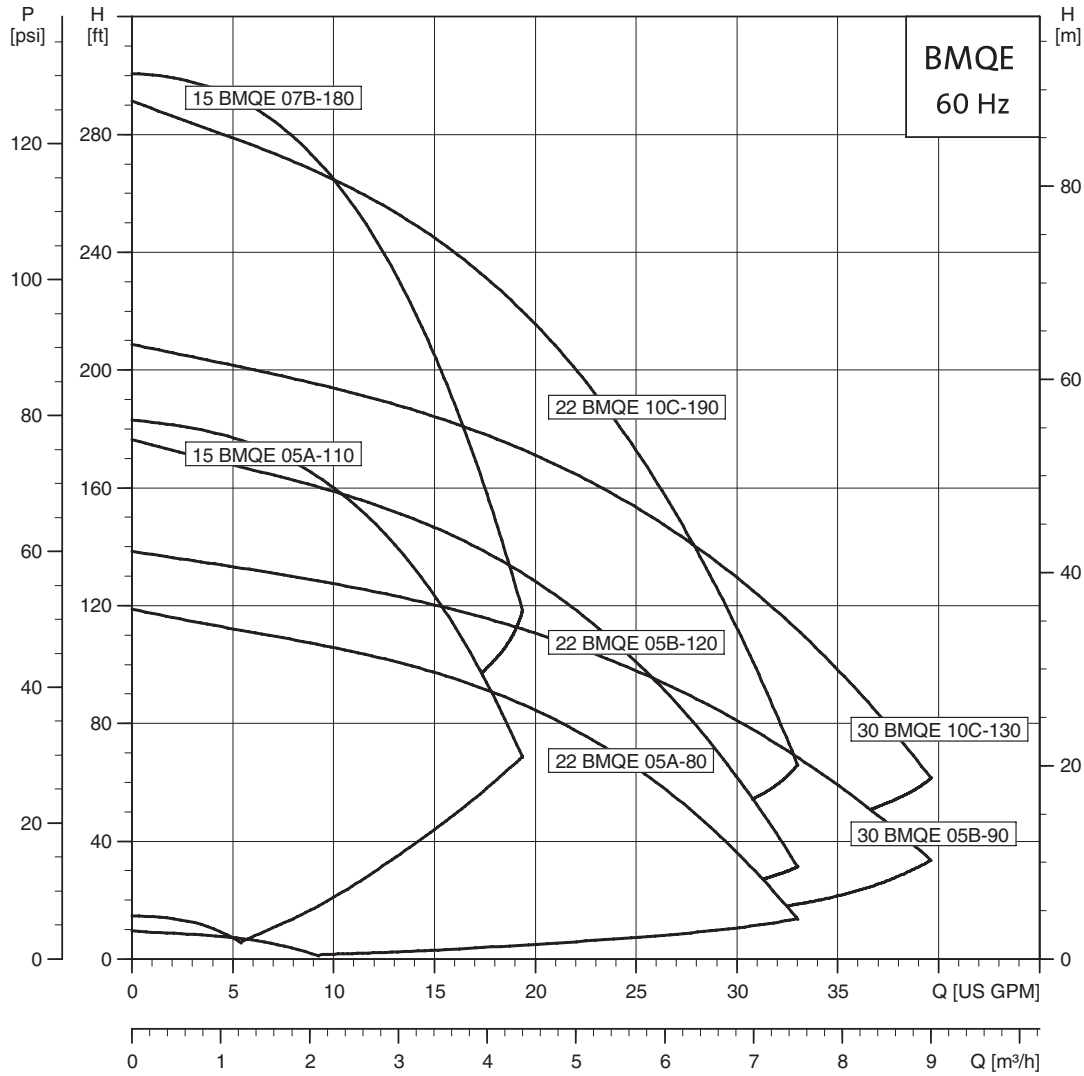

Product range

Range	BMQE 15	BMQE 22	BMQE 30
Nominal flow rate [US GPM (m ³ /h)]	15 (3.4)	22 (5.0)	30 (6.8)
Temperature range	+32 to +95°F (0 to +35°C)		
Maximum inlet pressure [PSI (bar)]	217 (15)		
Maximum working pressure [PSI (bar)]	347 (23)		
Maximum efficiency [%]	57	62	60
Flow range [US GPM (m ³ /h)]	0 to 19 (4.3)	0 to 33 (7.5)	0 to 39 (8.8)
Maximum pump pressure [ft (m/PSI)]	300 (91.4)/130	290(88.4)/125	208(63.4)/90
Pipe connection	1.25" NPT inlet / 1" NPT discharge		

Materials BMQ

Sleeve			
Pos.	Description	Material	AISI
90	Sleeve	Stainless steel	316
91	Flange	Stainless steel	304
92	Cable entry	Stainless steel/ FKM	304
93	Air vent screw	Stainless steel	304
94	O-ring	FKM	

Pump			
Pos.	Description	Material	AISI
1	Valve casing	Polyamide/PVDF	
1a	Discharge chamber	Stainless steel	304
1d	O-ring	NBR rubber	
3	Valve seat	NBR rubber	
4a	Empty chamber	Polyamide/PVDF	
6	Top bearing	NBR rubber	
7	Neck ring	Polyamide/PVDF	
7a	Lock ring	Stainless steel	310
7b	Neck ring retainer	Polyamide/PVDF	310
9b	Empty chamber	Polyamide/PVDF	
9c	Bottom chamber	Polyamide/PVDF	
13	Impeller with TC bearing	Polyamide/PVDF	
14	Suction interconnector	Polyamide/PVDF	
14a	Ring	Stainless steel	304
16	Shaft with coupling	Stainless steel	304
30	Cone	Polyamide/PVDF	
32	Guide vanes	Polyamide/PVDF	
39	Spring	Stainless steel	316 LN
55	Pump sleeve	Stainless steel	316
64	Priming screw	Polyamide/PVDF	
70	Valve guide	Polyamide/PVDF	
86	Lip seal	NBR rubber	
87	Cone complete	Polyamide/PVDF	

Motor			
Pos.	Description	Material	AISI
201	Stator	Stainless steel	304
202	Rotor	Stainless steel	304
202a	Stop ring	PP	
202b	Filter	Polyester	
203	Thrust bearing	Carbon	
205	Radial bearing	Ceramic/TC	
220	Motor cable with plug	EPR	
222a	Filling plug	NBR rubber	
224	O-ring	FKM	
225	Top cover	PPS	
232	Shaft seal	NBR rubber	

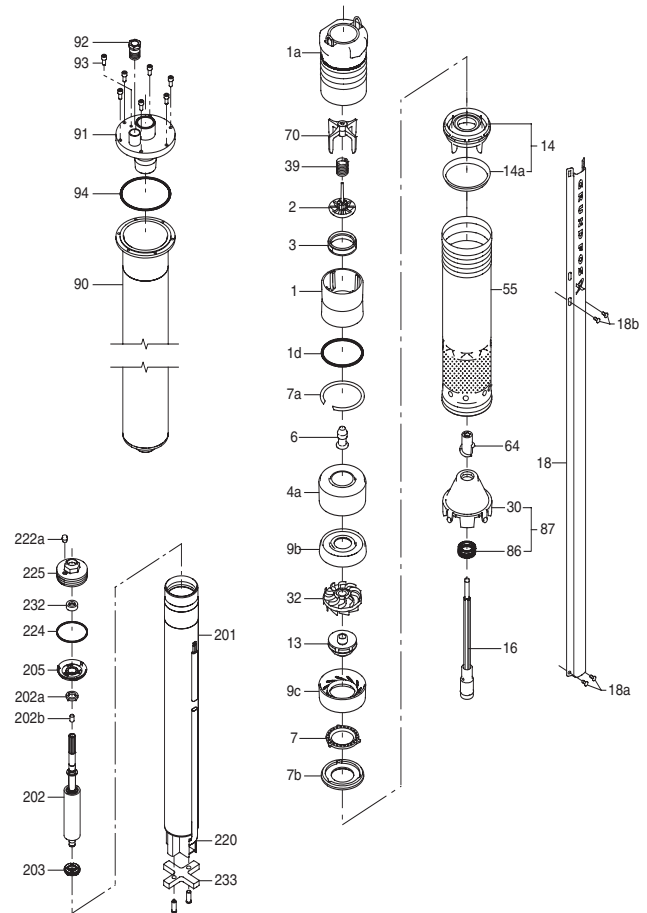

Type key

Example	22	BMQ	E	05B	120
Rated flow in US GPM					
EZ Boost pump					
Electronically controlled pump via EZ Boost controller					
Motor HP					
Head in feet at rated flow					

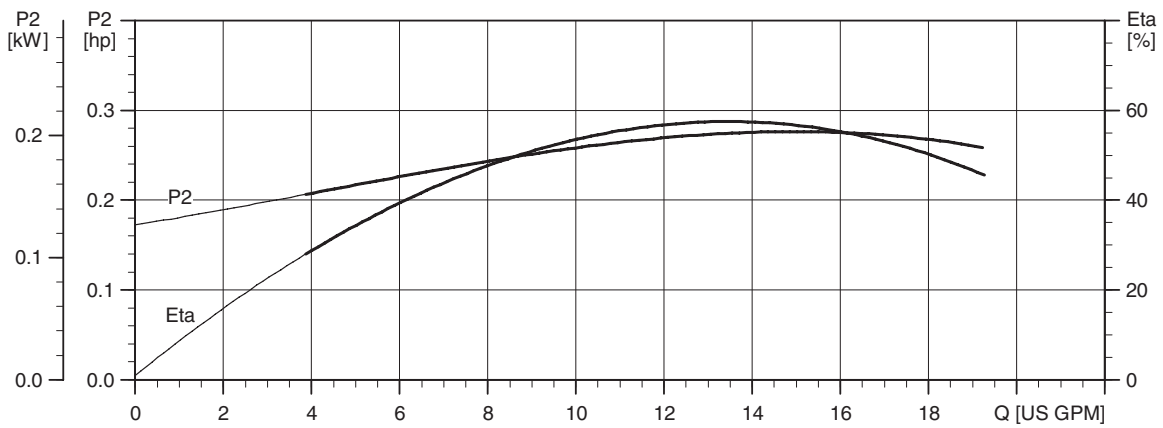
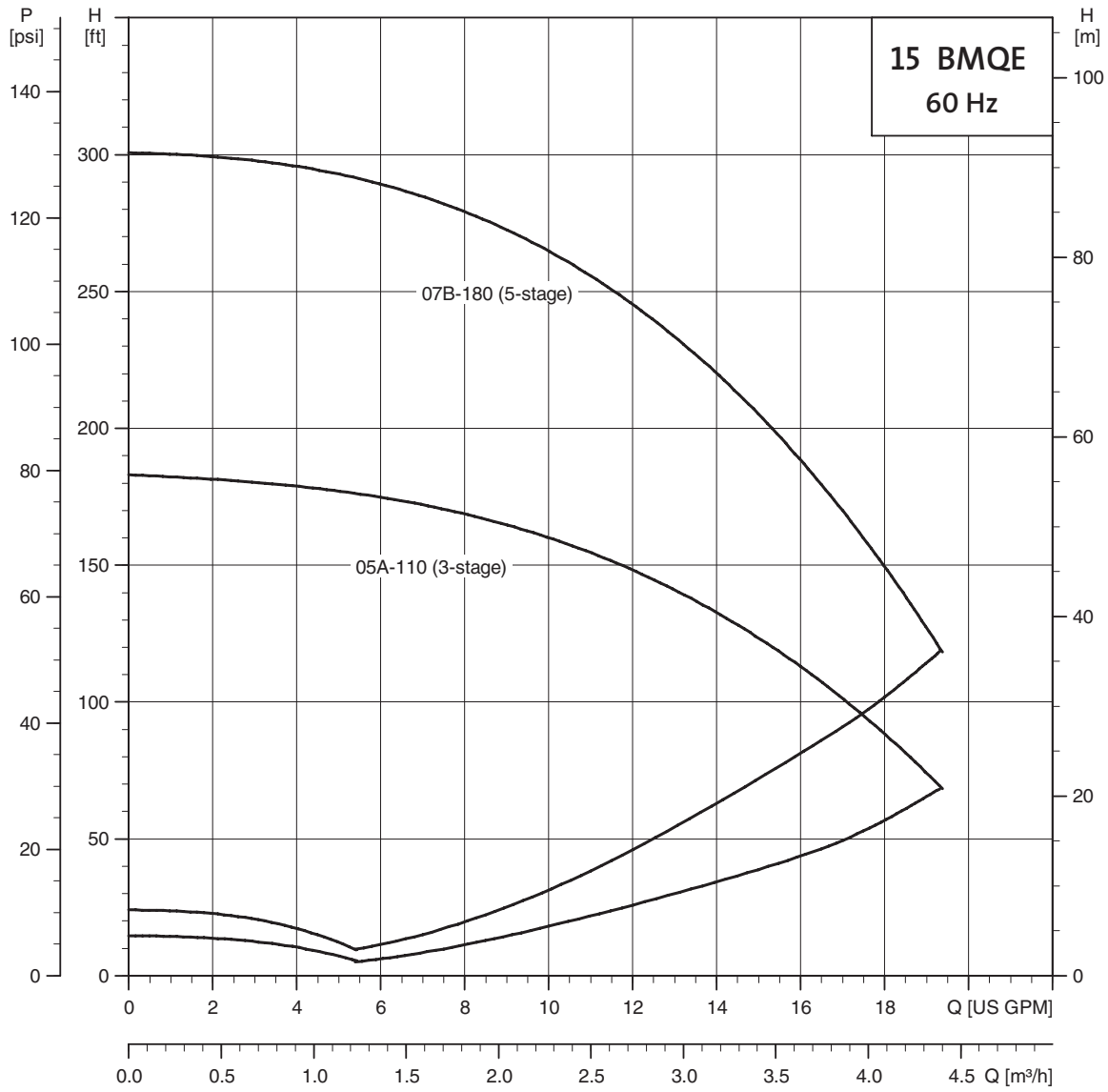

TK01 3098 3304

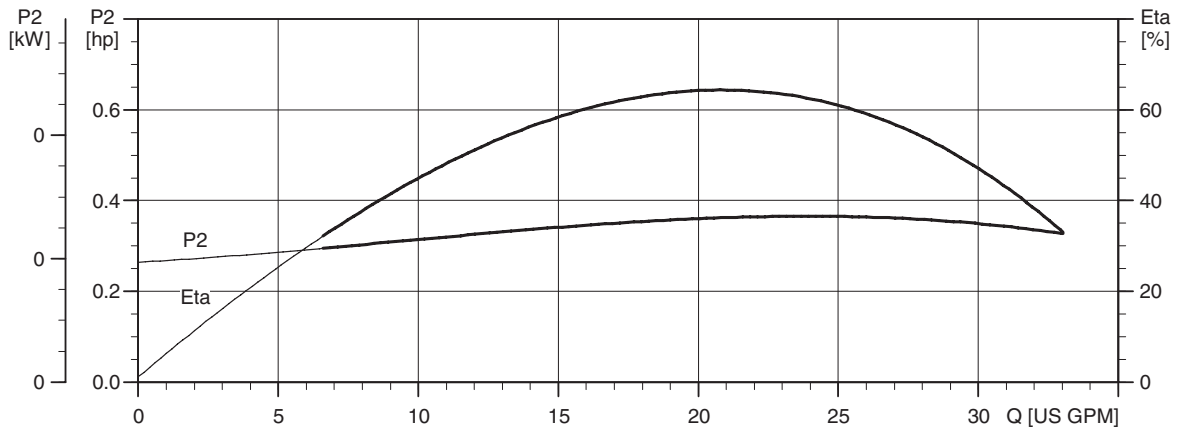
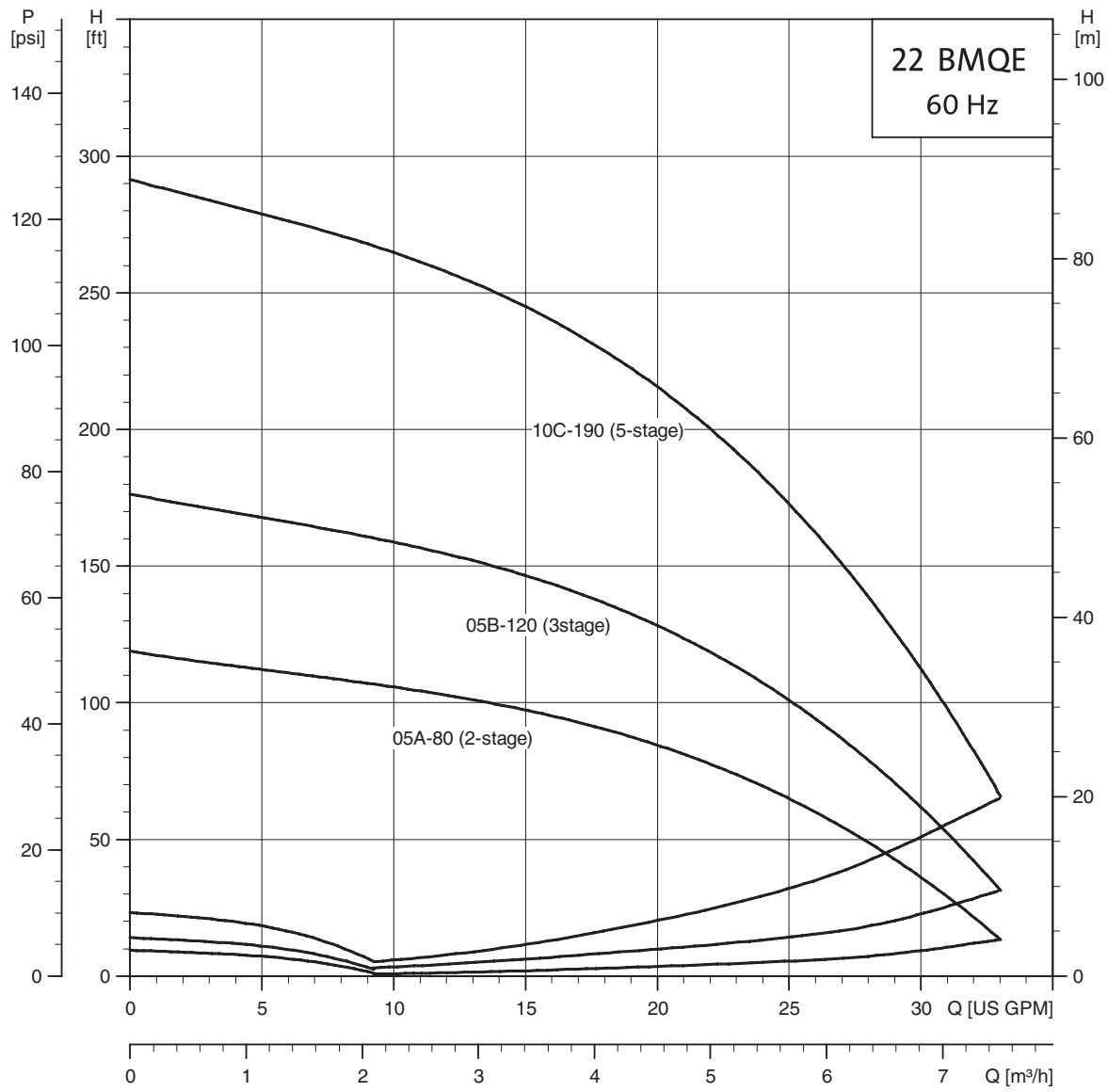

TK01 3099 3304

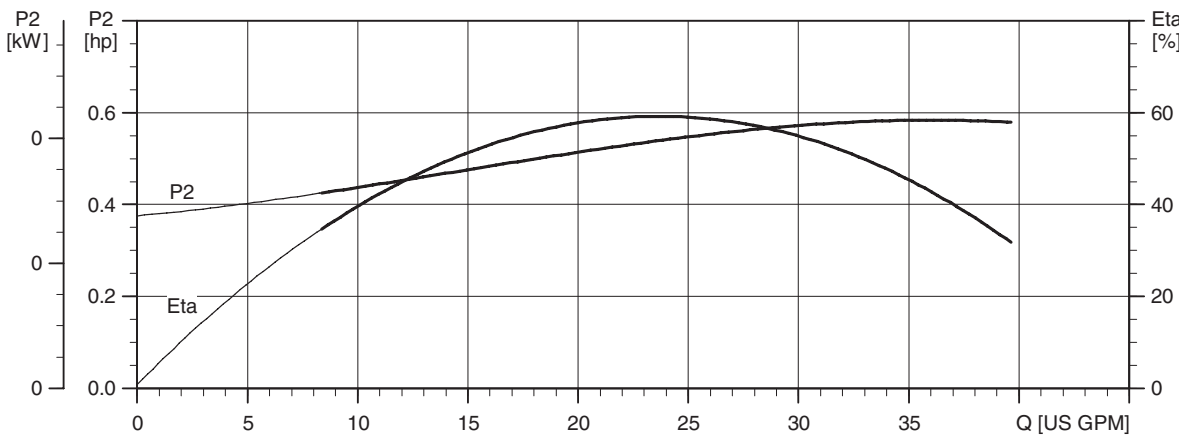
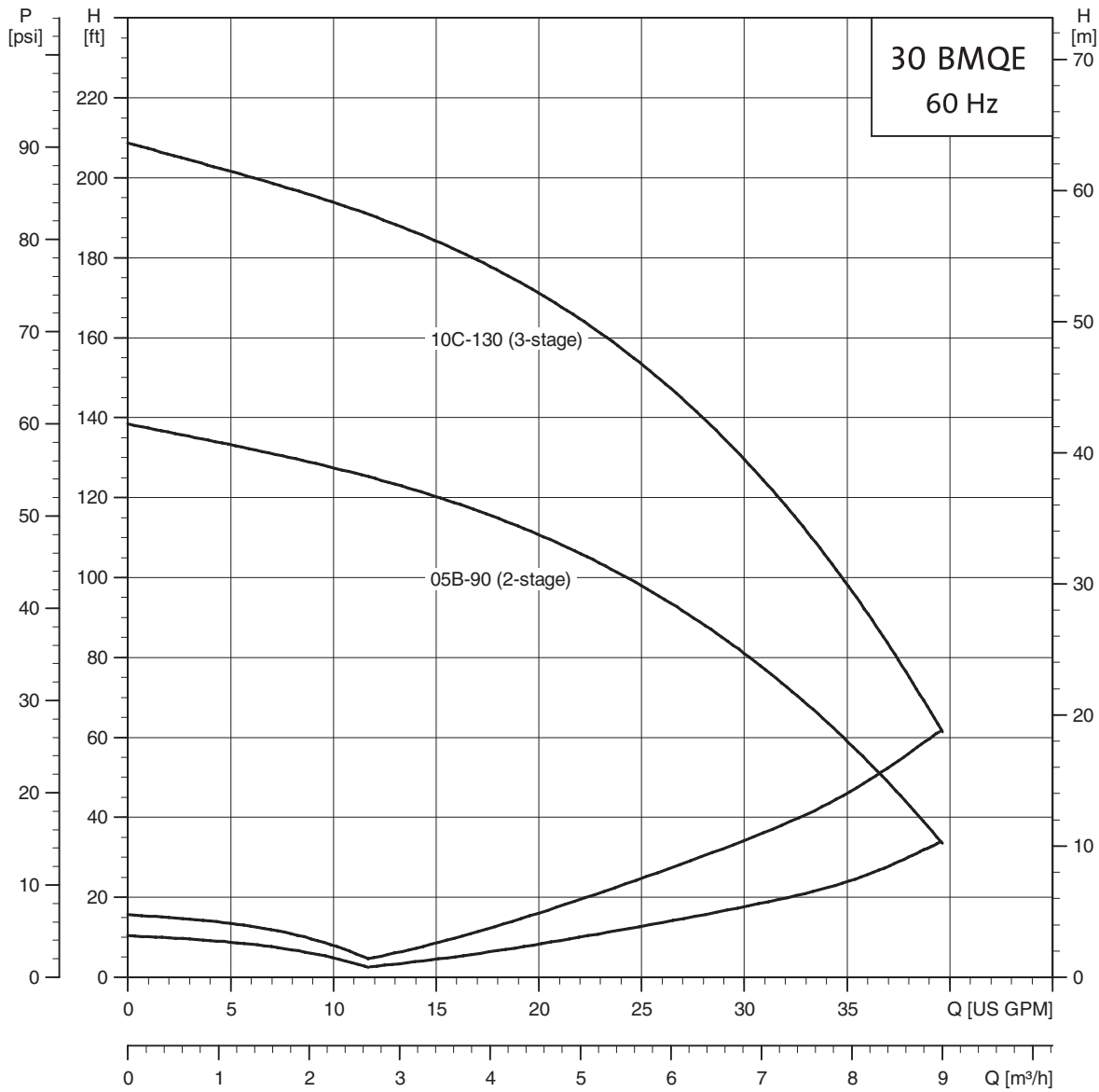

TK01 3100 3304

Weights and electrical data

Model	Material number	Max. motor output [P2]		Rated Voltage	Rated current [A]	Locked rotor current [A]	Shipping weight [lb (kg)]	Shipping volume [ft³ (m³)]
		hp	kW					
15 BMQE 05A-110	91128524	0.845	0.63	110-115	9.2	11.1	26 (11.8)	0.9 (0.025)
22 BMQE 05A-80	91128527	0.845	0.63	110-115	7.8	11.1	26 (11.8)	
15 BMQE 05A-110	91128525	0.845	0.63	200-240	4.6	5.0	26 (11.8)	
15 BMQE 07B-180	91128526	1.408	1.05	200-240	7.1	8.0	29 (13.2)	
22 BMQE 05A-80	91128528	0.845	0.63	200-240	3.9	5.0	26 (11.8)	
22 BMQE 05B-120	91128529	1.408	1.05	200-240	5.6	8.0	29 (13.2)	
22 BMQE 10C-190	91128530	2.320	1.73	200-240	9.9	11.1	31 (14.1)	
30 BMQE 05B-90	91128531	1.408	1.05	200-240	6.0	8.0	31 (14.1)	
30 BMQE 10C-130	91128533	2.320	1.73	200-240	9.5	11.1	31 (14.1)	

Dimensional sketch [in/mm]

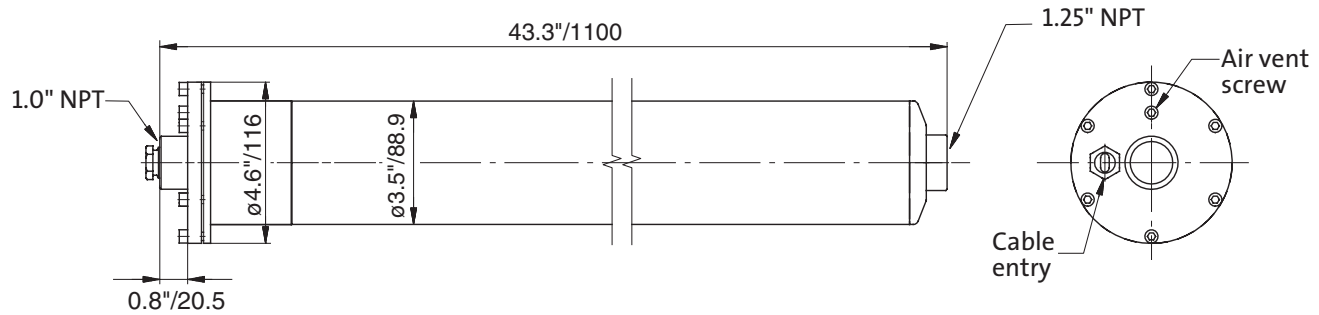

Technical data - BMQE pump

Main power supply to pump	1 x 200-240 V -10%/+6%, 60 Hz 1 x 110-115 V -10%/+6%, 60 Hz
Starting	Soft starting.
Stopping	Soft stopping when stopped by the EZ Boost controller
Run-up time	Maximum: 2 seconds. No limitation to the number of starts/stops per hour.
Motor protection	Built into the pump. Protection against: Dry running Over voltage and under voltage 230 V cuts out at < 150 V and > 280 V 115 V cuts out at < 75 V and > 150 V Overload Over temperature
Sound pressure level	The sound pressure level is < 74 db[A] at a distance of 3 feet (1 meter). It is recommended by Grundfos that the pump be installed with sound and vibration dampening equipment such as; flexible piping adapters and anti-vibration mounting. The pump should not be mounted in or adjacent to living quarters. The pump can also be wrapped with sound proofing insulation to reduce noise. (See page 16, EZ Boost System Diagram.)
Reset function	BMQE pumps can be reset via EZ Boost controller.
Power factor	PF = 1.
Operation via generator	It is recommended that the generator output is equal to the motor input power P1 [kW] plus 50%; min. P1 +10%, however.
Pipe connection	1.25" NPT inlet / 1" NPT discharge.
Strainer	Holes of the strainer: ø0.09" (2.3 mm)
Marking	UL Listed, CE (SQE Pump with MSE 3 motor only)

EZ Boost Controller

The EZ Boost controller is a control and communication unit especially developed for the BMQE booster pumps in constant pressure applications.

The EZ Boost controller provides:

- Full control of the BMQE pumps
- Two-way communication with the BMQE pumps
- Possibility of adjusting the pressure
- Alarm indication (LED) when service is needed
- The possibility of starting, stopping and resetting the pump simply by means of a push-button

The EZ Boost controller communicates with the pump via power line communication, meaning that no extra cables are required between the EZ Boost controller and the BMQE pump.

The EZ Boost controller features the following indications (see drawing below):

1. Flow indicator
2. System pressure setting
3. System ON/OFF
4. Button lock indicator
5. Dry-running indicator
6. Service needed in case of:
 - No contact to pump
 - Over voltage
 - Under voltage
 - Speed reduction
 - Over temperature
 - Overload
 - Sensor defective

The EZ Boost controller incorporates external signal input for pressure sensor and a pump status relay for use with devices dependant on pump status.

Voltage	1 x 100-240 V -10%/+6%, 60 Hz
Power consumption	5 W
Current consumption	Maximum 130 mA
Enclosure class	NEMA 3R (IP 55)
Ambient temperature	In operation: -22 to +122°F (-30 to +50°C) during storage: -22 to +140°F (-30 to +60°C)
Relative air humidity	95%
Pump cable	Maximum length between EZ Boost controller and pump: 650 ft (198 m).
Back-up fuse	Maximum: 16 A
Marking	UL Listed, CE
Load	Max. 100 mA

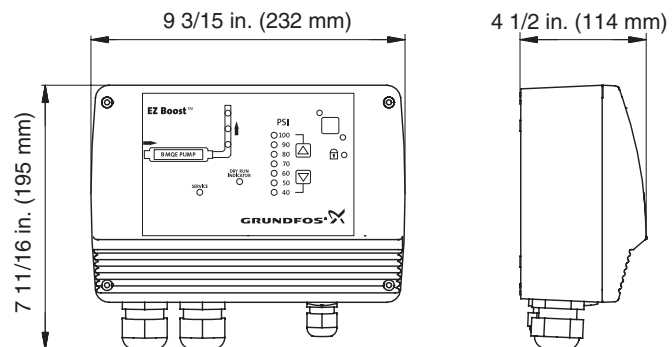
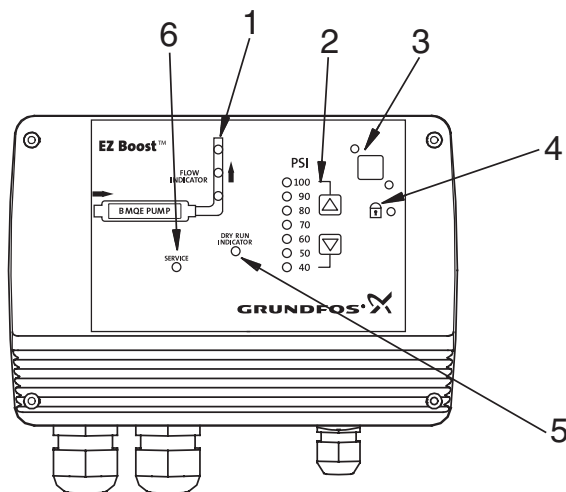
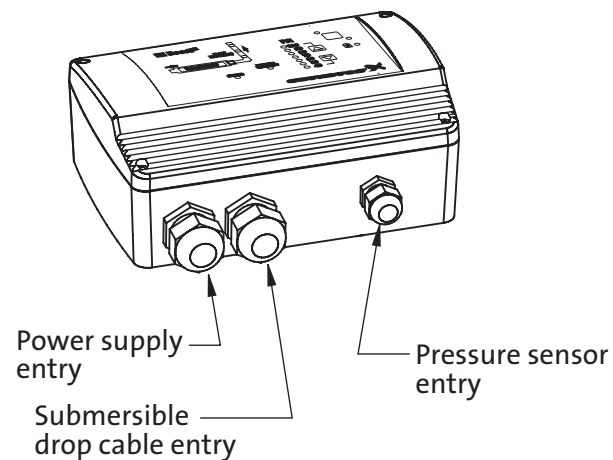

Accessories

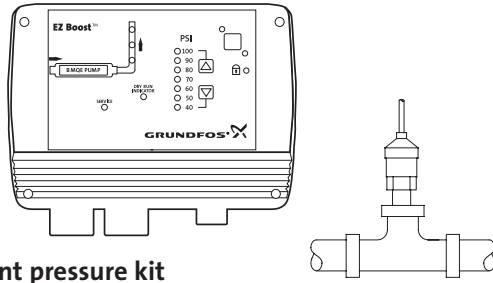

EZ Boost constant pressure kit

Description	Rating	Material number
EZ Boost controller and pressure sensor	40 to 100 PSI setting range	91128636

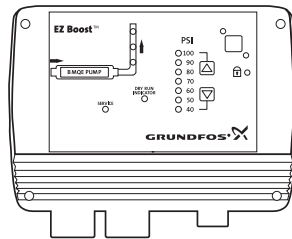

EZ Boost controller

Description	Rating	Material number
EZ Boost controller	40 to 100 PSI setting range	91121987

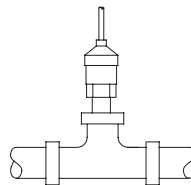

Sensor

Description	Rating	Material number
Pressure sensor kit for EZ Boost controller	0 to 120 PSI, 1/2" NPT	96437852

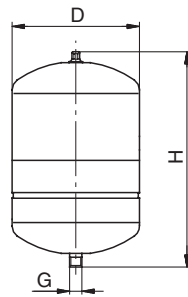

Diaphragm tank

Description	G connection	D [in (mm)]	H [in (mm)]	Weight [lbs (kg)]	Material number
Diaphragm tank, 2 gallon	3/4" NPT	8 (203)	12.63 (321)	5 (2.3)	91121984

Duty range	Materials
Pre-charge pressure: 40 PSI	Liner: Polypropylene
Max. operating pressure: 150 PSI	Connection: Lead-free brass
Max. liquid temperature: 200°F	Tank: Stainless steel, AISI 304

EZ Boost Quick Guide

EZ Boost Quick Selection Guide

Example:

1. The maximum demand is 15 GPM (3.4 m³/h).
2. The pressure required is 70 PSI system pressure at the taps in the building.
3. The normal minimum inlet pressure (e.g. city pressure) is 20 PSI.
4. The additional boost required is 50 PSI at 15 GPM (3.4 m³/h).
5. Select a 15 BMQE 05A-110.

Additional (boost) pressure required in PSI

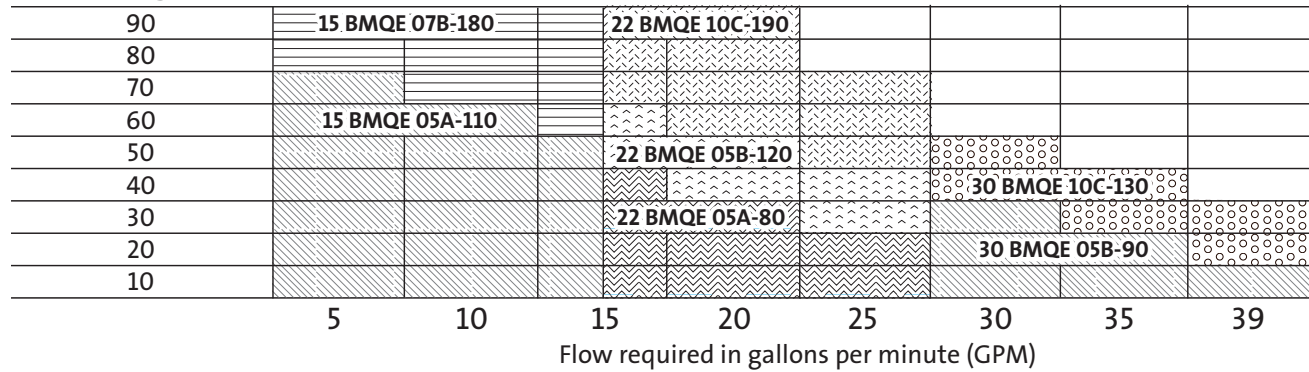

EZ Boost System Diagram

The EZ Boost Constant Pressure System should consist of:

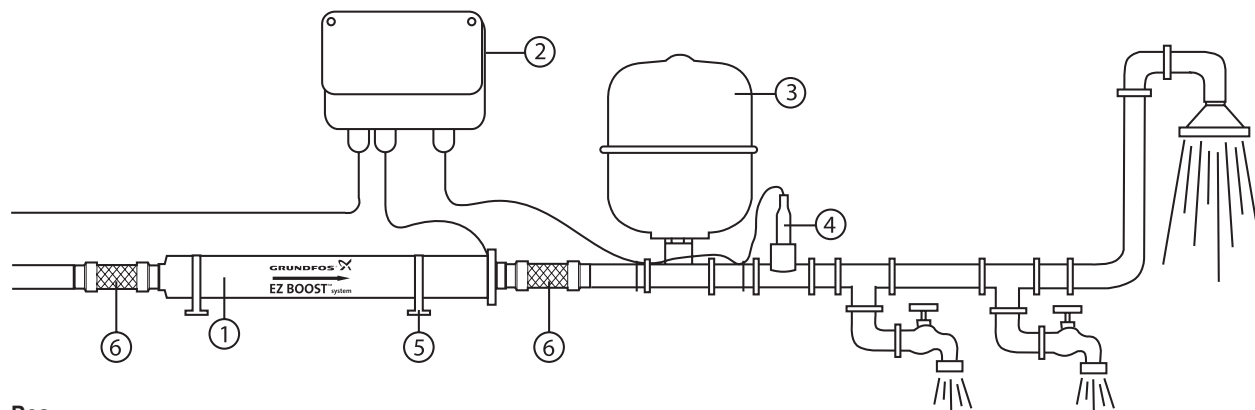

Pos.

- | | |
|--|----------------------|
| 1. EZ Boost BMQE pump | 4. Pressure sensor |
| 2. EZ Boost controller | 5. Mounting brackets |
| 3. Diaphragm tank
(recommended size 2 U.S. gallons (8 liter)/130 psi) | 6. Flex connector |

PRE-INSTALLATION

A guide to the EZ Boost System

The EZ Boost Constant Pressure System automatically balances water surges and equalizes flow and pressure according to consumption. In other words, the system maintains a constant water pressure in spite of varying water consumption. The pressure is registered by means of the pressure sensor and transmitted to the controller. The controller adjusts the EZ Boost BMQE pump performance accordingly. The EZ Boost Constant Pressure System features:

- Quick and easy installation: ready-to-use system requiring minimum space
- High user convenience: constant pressure regardless of water consumption
- Easily adjustable pressure level: push button control
- Continuous control and monitoring of pump operation
- Integrated dry-running protection
- Integrated overload protection
- Integrated protection against over voltage and under voltage
- Soft start system

Function

When a tap is opened, the pressure in the tank will start to drop. The system maintains a constant pressure within the maximum pump performance in spite of varying water consumption.

The pressure is registered by means of the pressure sensor, which transmits a signal to the controller. The controller adjusts the pump performance accordingly to maintain constant pressure by changing the pump speed.

At low flow the pressure will drop slowly. When the pressure in the tank is 7 PSI below the setpoint, the pump will start. When the pressure is 7 PSI above the setpoint, the pump will stop.

Even though the EZ Boost controller is controlling the pressure within ± 3 PSI, larger pressure variations may occur in the system. If the consumption is suddenly changed, e.g. if a tap is opened, the water must start flowing before the pressure can be made constant again. Such dynamic variations depend on the pipe work, but, typically, they will lie between 7 and 14 PSI. If the desired consumption is higher than the quantity the pump is able to deliver at the desired pressure, the pressure follows the pump curve as illustrated in the far right of fig. 1.

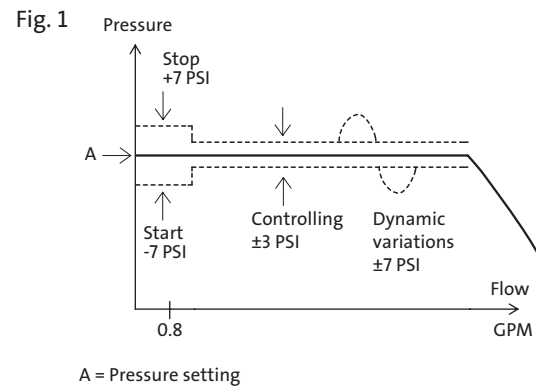

At large flow rates, the pressure will drop quickly and the pump will start immediately and maintain constant pressure. When the system is running, the EZ Boost controller makes small adjustments to the pressure to detect whether there is consumption. If there is none, the pump will simply refill the tank and stop after a few seconds.

BMQE pumps connected in parallel

When connecting BMQE pumps in parallel as shown in fig. 5, a **separate EZ Boost controller must be used on each BMQE**. Set the pressure on one BMQE 10 PSI lower than the other.

For BMQE pumps connected in parallel, mounted above each other, it is recommended to connect the pipes as shown in fig. 5. This layout ensures that the BMQE pumps are filled with water before starting.

Fig. 5 Booster unit with two BMQE pumps connected in parallel, mounted above each other.

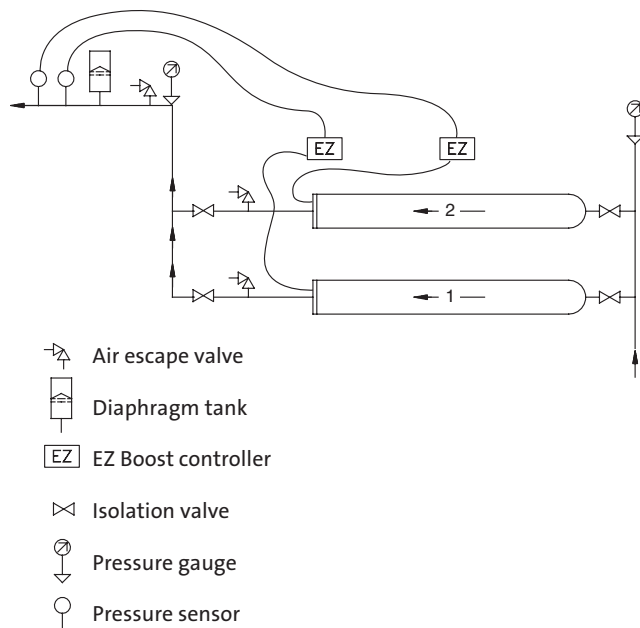

Notes:

- All BMQE modules are supplied with a non-return valve.
- BMQE modules connected in parallel may also be installed vertically.
- As venting problems may arise in such installations, it is advisable to install suitable air vent devices.
- The BMQE should be positioned with the discharge and air vent at the top when installed vertically.
- When the maximum flow for BMQE pumps in parallel will exceed 35 GPM, a 4-gallon or two 2-gallon diaphragm tank(s) should be used.





MQ

Flow based pressure boosting system
60 Hz



BE > THINK > INNOVATE >

GRUNDFOS



Contents

General data	Page No.
Application	29
Type key	29
Pumped liquids	29
Operating conditions	29
Technical data	29
Features and benefits	29
Control panel	30
Product range	30
Technical data	
Electrical data	30
Dimensions	30
Material specifications	31
Flooded suction performance curves	32
MQ 3-35 suction lift performance curves	33
MQ 3-45 suction lift performance curves	34
Accessories	35

Application

The MQ pump is designed for water supply and pressure boosting ...

- homes
- cabins, cottages
- on farms as well as
- gardens

The pump is suitable for pumping of potable water and rain water.

Type Key

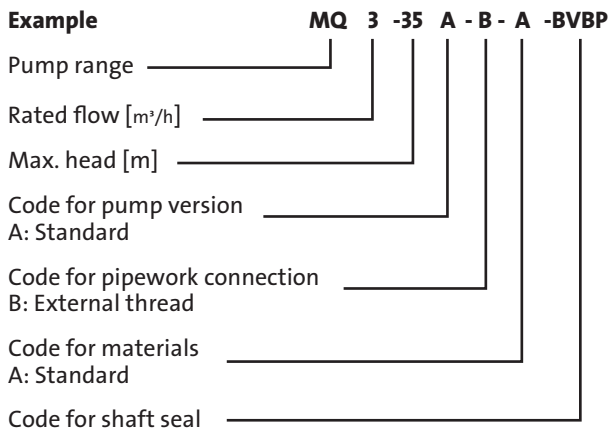

Pumped liquids

Potable water, rain water or other clean, thin, non-aggressive liquids not containing solid particles or fibers.

Operating conditions

System pressure:	Max. 109 psi (7.5 bar).
Inlet pressure:	Max. 44 psi (3 bar).
Suction lift:	Max. 26 ft (8 m).
Liquid temperature:	32°F to +95°F (0°C to +35°C).
Ambient temperature:	32°F to +113°F (0°C to +45°C).

Technical data

Mains voltage:	
• 115 V models:	1 x 110-120 V, 60 Hz
• 230 V models:	1 x 220-240 V, 60 Hz.
Voltage tolerances:	-10% / +6%.
Enclosure class:	IP54.
Insulation class:	B.
Sound pressure level:	≤ 55 dB(A).
Agency approvals:	UL, cUL

Features and benefits

- **Complete system**
The MQ is a complete, all-in-one unit, incorporating pump, motor, diaphragm tank, pressure and flow sensor, controller and check valve.
The controller ensures that the pump starts automatically when water is consumed and stops automatically when the consumption ceases. In addition, the controller protects the pump in case of faults.
- **Installation**
Due to its compact design, the pump does not take up much space and is easy to install. No space around the pump is required.
- **Simple operation**
The pump features a user-friendly control panel with ON/OFF button and indicator lights for indication of the operational state of the pump.
- **Self-priming pump**
As it is self-priming, the MQ is able to pump water from a level below the pump. Provided it is filled with water, the pump is able to lift water from a depth of 26 ft (8 m) in less than 5 minutes. This facilitates installation and start-up of the pump and provides more reliable water supply in installations where there is a risk of dry running and leakages in suction hose or pipes.
- **Built-in protective functions**
If exposed to dry running, excessive temperature, or any overload condition the pump will stop automatically, thus preventing a motor burnout.
- **Automatic reset**
The pump features an automatic reset function. In case of dry running or similar alarm, the pump will stop. Restarting will be attempted every 30 minutes for a period of 24 hours. The reset function can be deactivated.
- **Low noise level**
Thanks to its hydraulic design and internal cooling, the pump is very quiet, which makes it suitable for many applications.
- **Pressure tank**
The built-in pressure tank reduces the number of starts and stops in case of leakages in the pipe system, causing less wear on the pump.
- **Maintenance**
No maintenance of the pump is required.

Control panel operation

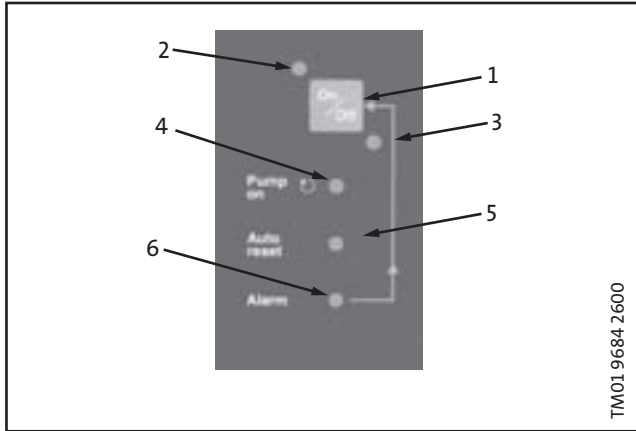

Pos.	Function	Description
1	ON/OFF button	The Pump is started and stopped by means of the ON/OFF button.
2	Power indicator lights	Indicates that the pump is ready for operation (green).
3		Indicates that the pump is on standby (red).
4	Pump ON (green)	Indicates that the pump is running.
5	Auto reset (green)	Indicates that the auto reset function is active. After an alarm, restarting will be attempted every 30 minutes for a period of 24 hours.
6	Alarm (red)	Indicates that the pump is in alarm state. Manual resetting is possible by pressing the ON/OFF button.

Product range and electrical data

Part Number	Model	PH & V	AMPS		P2		Weight Net Pounds	Cord Connection	Plug
			Run	Start	W	HP			
96860172	MQ 3-35	1X110-120V	8	29	585	0.75	30.1	7.54' - 2300mm SJTW-A 18 awg	UL Approved NEMA 5-15P - V125
96860195	MQ 3-45	1X110-120V	10	29	725	1	30.2	7.54' - 2300mm SJTW-A 18 awg	UL Approved NEMA 5-15P - V125
96860201	MQ 3-35	1X220-240V	4	15	565	0.75	30.1	7.54' - 2300mm SJTW-A 18 awg	UL Approved NEMA 6-15P - V250
96860207	MQ 3-45	1X220-240V	4.8	15	716	1	30.2	7.54' - 2300mm SJTW-A 18 awg	UL Approved NEMA 6-15P - V250

Dimensions

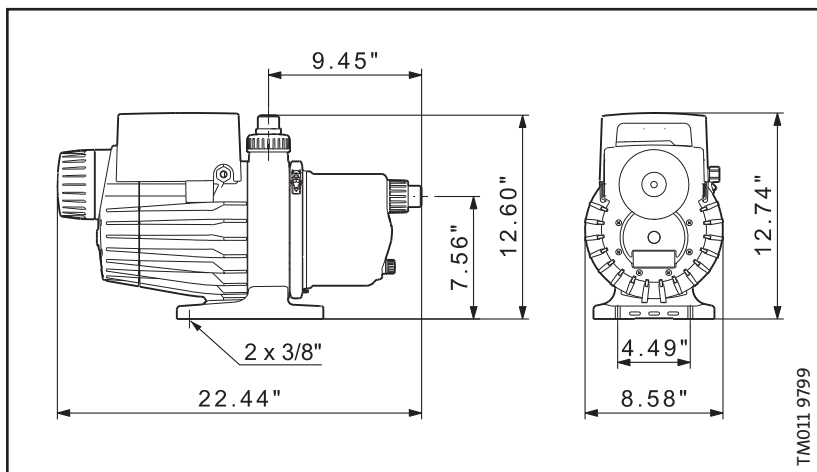

Material specification

Pos.	Components	Material
2	Support flange	PP+30% Glass Fiber HB (f1)
4	Chamber	PPO+20% Glass Fiber
7	Drain and priming plug	PPO+20% Glass Fiber
10	Self-priming valve	PP+30% Glass Fiber
14	Self-priming part	PPO+20% Glass Fiber
16	Pump sleeve	Stainless steel, DIN W.-Nr. 1.4301, AISI 304
42	Tank cover	PP+30% Glass Fiber HB (f1)
49	Impeller	PPO +20% Glass Fiber-PTFE
51	Motor cover	PP+30% Glass Fiber HB (f1)
65	Non-return valve	POM+25% Glass Fiber
92	Clamp	Stainless steel, DIN W.-Nr 1.4301, AISI 304
100a	Discharge port	PPO+20% Glass Fiber

Pos.	Components	Material
101	Suction port	PPO+20% Glass Fiber
103 104	Shaft seal: Stationary and rotating part	Carbon/ceramics/NBR rubber
149	Insulation disc	PA 5VA (Polyammide)
150	Shaft	Stainless steel, DIN W.-Nr 1.4005, AISI 416
	Motor sleeve	Stainless steel, DIN W.-Nr 1.4301, AISI 304
164	Terminal box cover	PP+30% Glass Fiber 5VA (f1)
174a	Pressure switch	POM+25% Glass Fiber / SIL Rubber (Silicone Rubber)
	Pressure switch membrane	SIL Rubber - Silicone Rubber.
180	Motor body	PP+30% Glass Fiber 5VA (f1)
184	Flow sensor	POM+25% Glass Fiber
	O-rings	NBR-rubber

POM: Polyoximetylen
 NR-rubber: Natural Rubber
 PPO: Polyphenylene Oxides
 PP: Polypropylene
 NBR-rubber: Nitrile-Butadiene Rubber

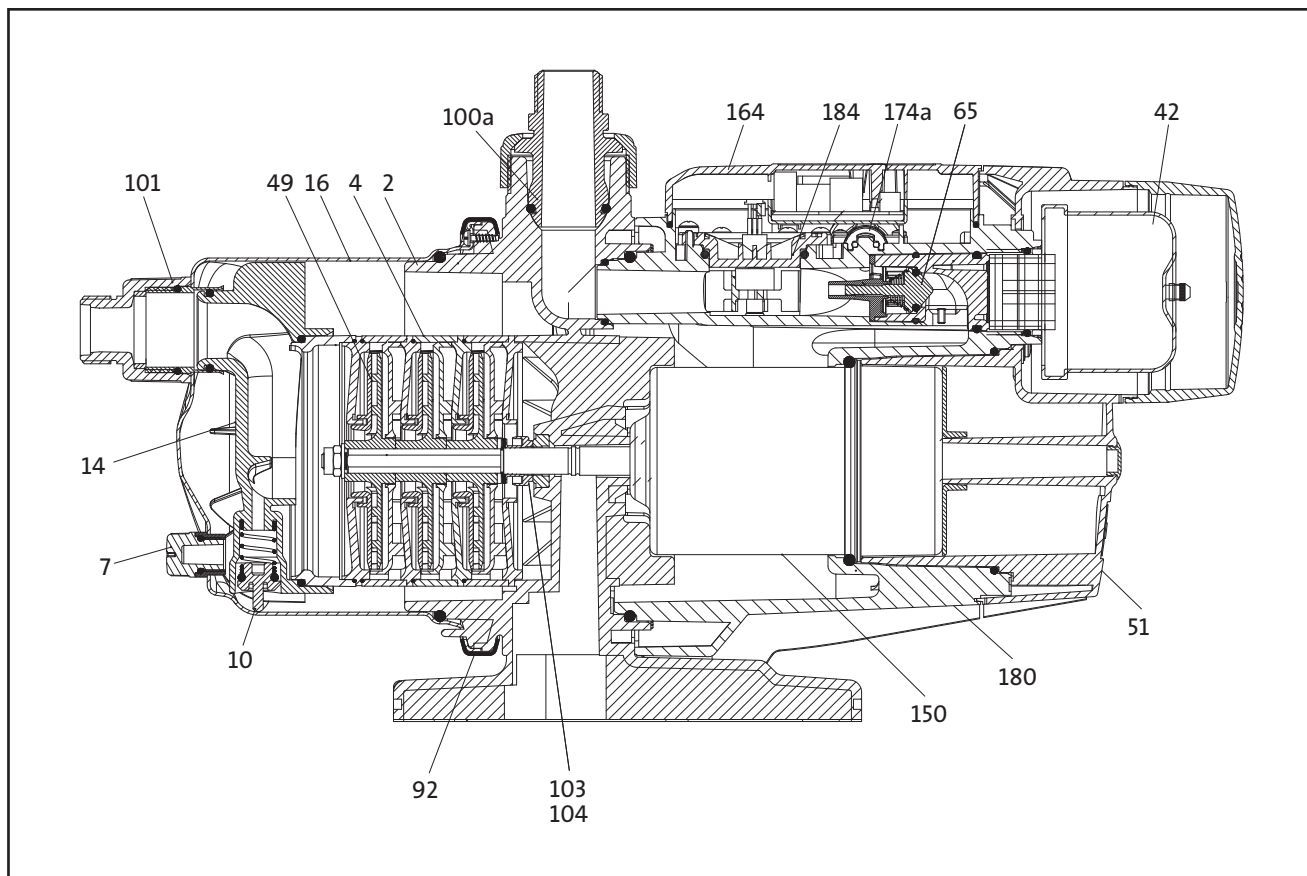

Flooded suction (0 PSI inlet) performance curves*

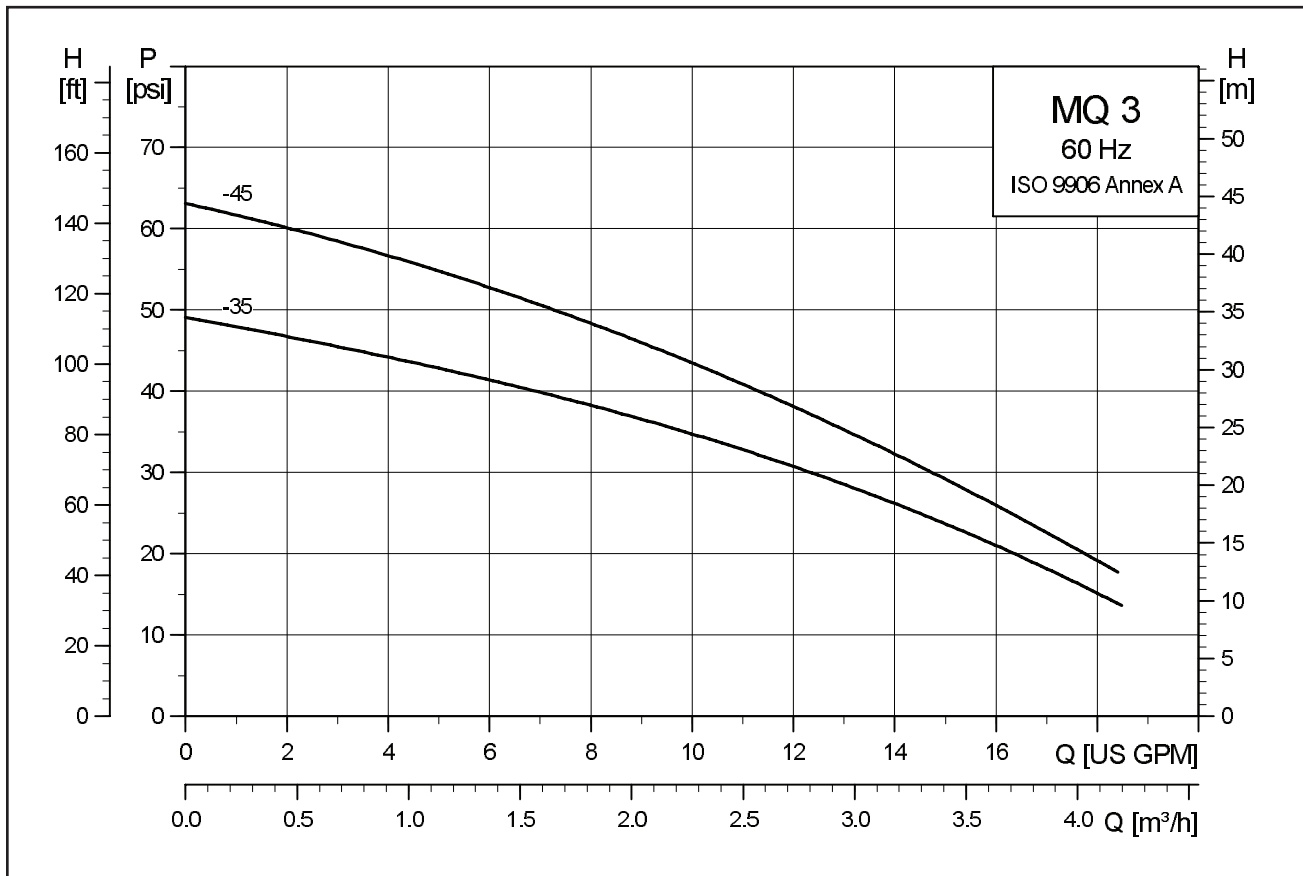

*See suction lift performance curves for installations with water level below intake.

MQ 3-35 Suction lift performance curves

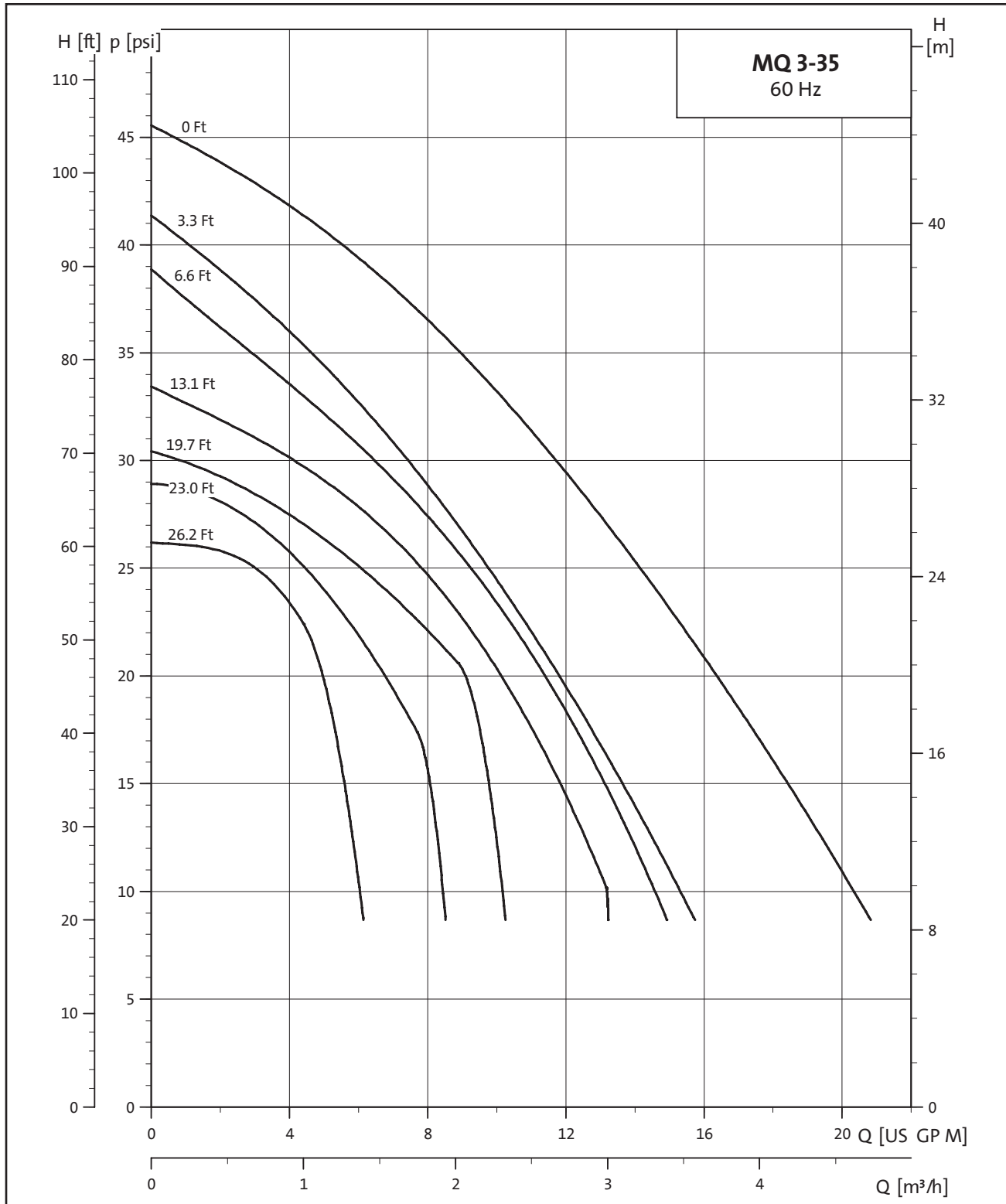

Provided it is filled with water, the pump is able to lift water from a depth of 26 ft (8 m) in less than 5 minutes.

MQ 3-45 Suction lift performance curves

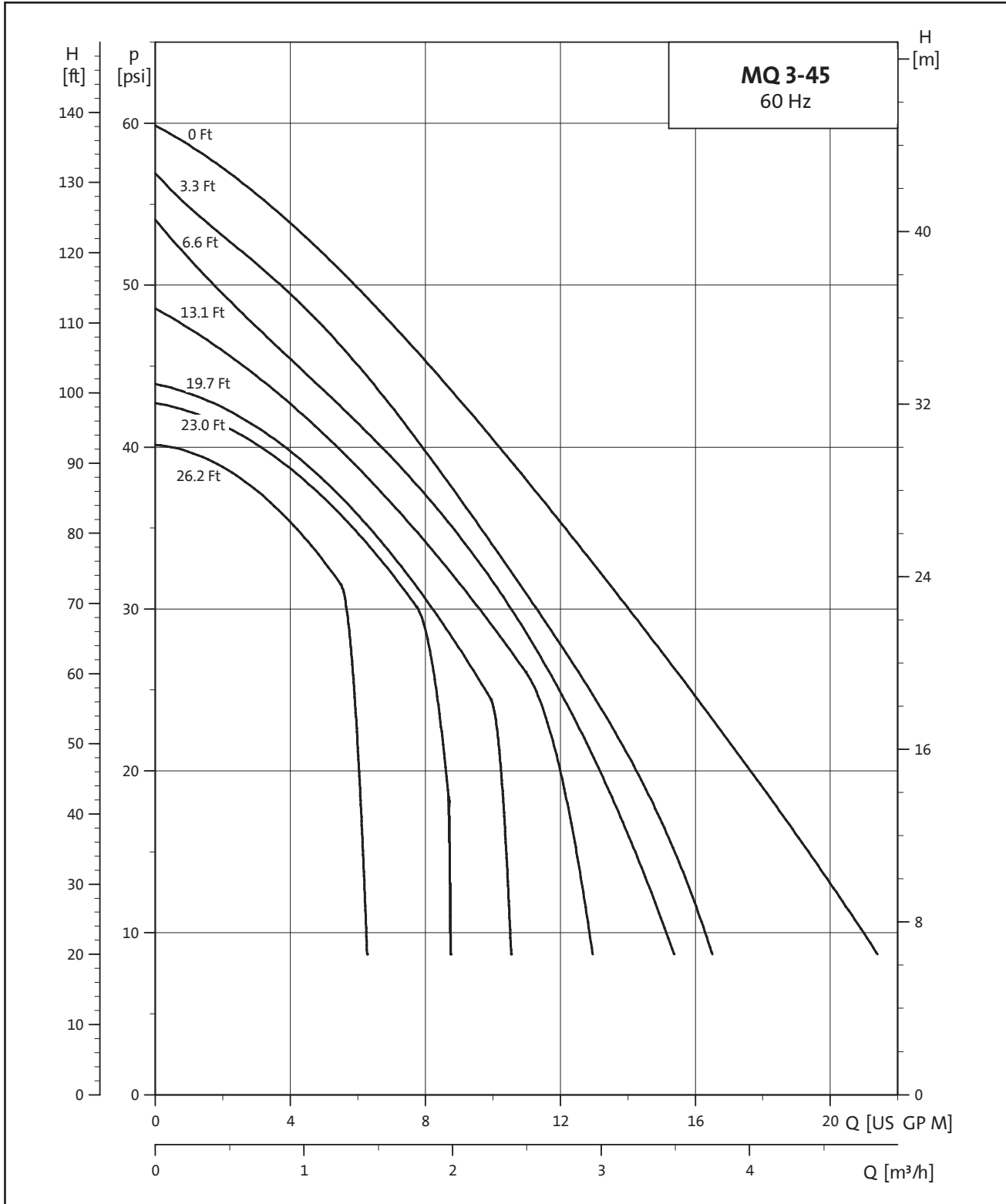

Provided it is filled with water, the pump is able to lift water from a depth of 26 ft (8 m) in less than 5 minutes.

Accessories

Protection Cover:

Designed to protect the MQ Key Pad and electronics in outdoor applications.

Protection cover is required for outdoor applications where the MQ is exposed to the elements.

The protection cover is sold as an accessory PN 96693071.

The cover is made of polypropylene and is a snap fit to the MQ. Two Velcro tabs are included with the accessory to help adhere the back end of the cover to the pump.





JPF, JPS, JDF

Shallow Well, Deep Well and
Convertible Jet Pumps
60 Hz

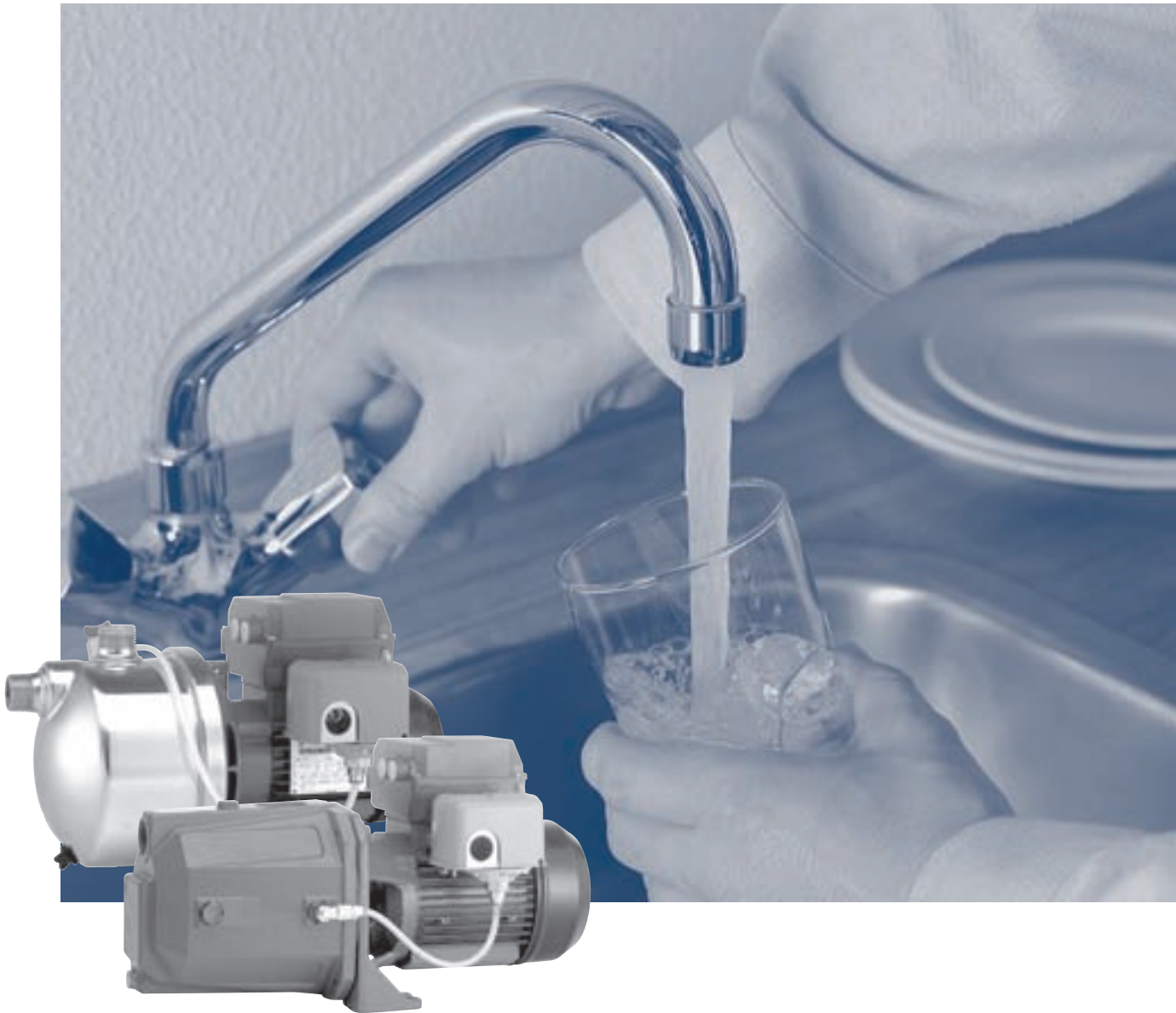

General data	Page No.
Performance range	39
Product range	40
Applications	41
Pumps	41
Motors	41
Pumped liquid	41
Agency approvals	41
Mounting position	41
Electrical data	42
Materials of construction	43
Technical data	
JPF 2A, 3A, 4A, 41A Shallow Well Cast Iron	46
Dimensions and Weights	46
Performance Chart	46
Performance Curves	47
JPF 5A, 7A Convertible Cast Iron	48
Dimensions and Weights	48
Conversion Instructions	48
Performance Chart	49
Performance Curves	49
Deep Well Performance Chart	50
JPS 2A, 4A Shallow Well Stainless Steel	51
Dimensions and Weights	51
Performance Chart	51
Performance Curves	52
JDF 2A, 4A Deep Well Cast Iron	53
Dimensions and Weights	53
Ejector Dimensions	53
Performance Chart	54
JPF3A Pump Tank Package Cast Iron	55
Dimensions and Weights	55
Performance Chart	55
JPS2A Pump Tank Package Stainless Steel	56
Dimensions and Weights	56
Performance Chart	56

Performance range

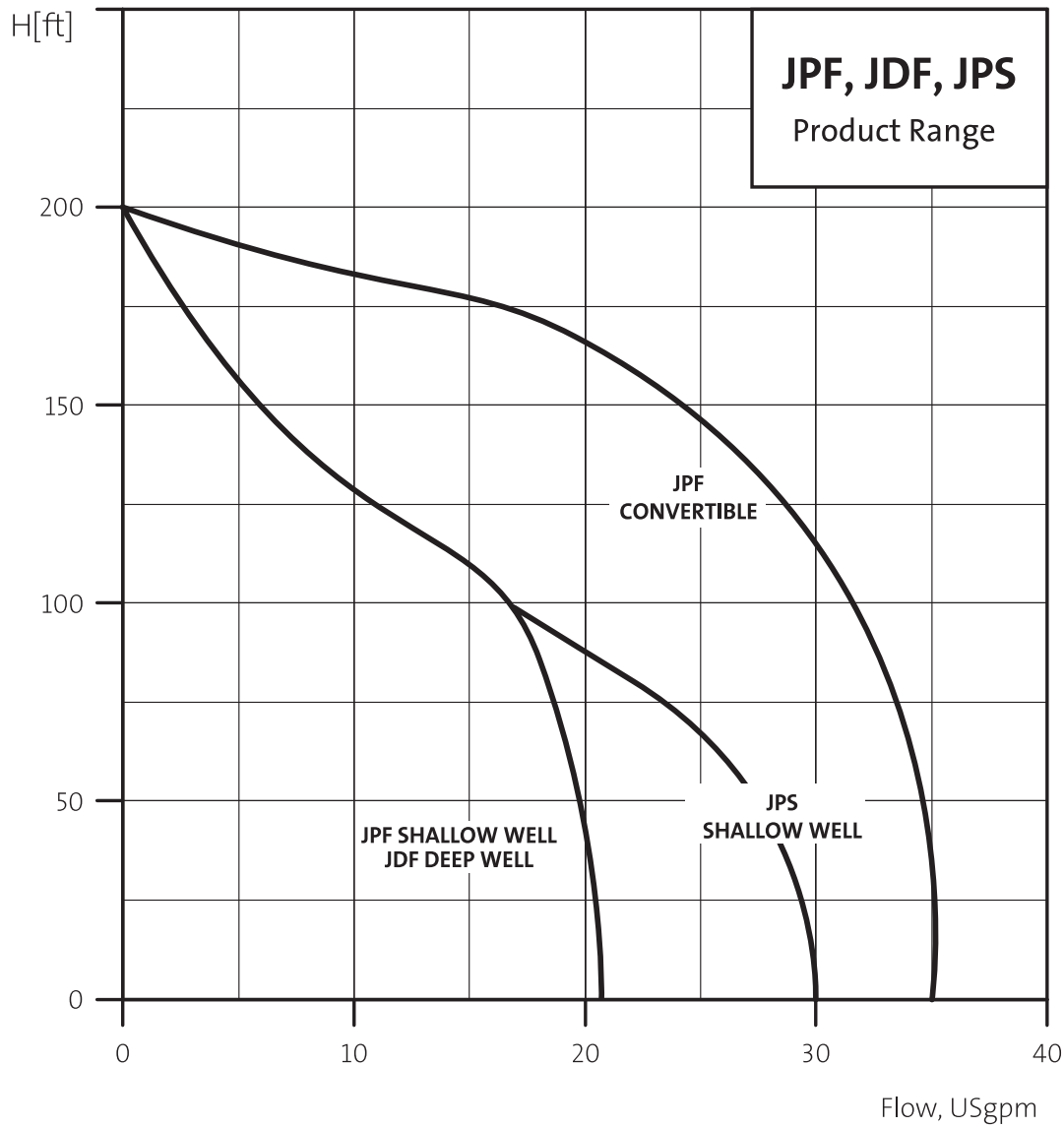

* Capacities given are for near-sea level installations.

Product range

Model	JPF 2-A	JPF 3-A	JPF 4-A	JPF 41-A	JPF 5-A	JPF 7-A	JPS 2-A	JPS 4-A	JDF 2-A	JDF 4
Flow range (U.S. gpm)	1.7-13	1.7-12.2	1.7-16	1.8-21	2.6-22	2.6-35	1.7-17	3.5-28.2	1.8-10.3	0.75-13.1
Max. pump head H(ft)	135	170	172	185	200	200	140	155	145	167
Max. working pressure (psi)	87	87	87	87	110	110	110	110	87	87
Motor power (hp), Nominal	1/3	1/2	3/4	1	1.5	2	1/2	1	1/2	3/4
Maximum Fluid Temperature range	14°F to 104°F (-10 to 40°C)*									
Maximum lift, Ft (Sea level)	26	26	26	26	140	140	26	26	70	80
Maximum Ambient Temp	34°F to 104°F (1 to 40°C)									
Factory Pressure -Switch setting (PSI)	20-40	30-50	30-50	40-60	50-70	50-80	30-50	30-50	30-50	30-50
Storage Temp	14°F to 104°F (-10 to 40°C)									
Relative Humidity	95%									
Maximum Starts per hour	20									

*Minimum fluid temperature on water, 32°F (0°C)

Applications

Shallow well, Deep well and Convertible pump applications. Grundfos jet pumps are self-priming centrifugal pumps suitable for domestic water supply systems, light agricultural and industrial water transfer applications

Pumps

JPF2A, JPF3A, JPF4A, JPF41A Pumps:

Rugged cast iron construction. Single-stage shallow well self-priming centrifugal pumps. End suction, top discharge arrangement and Technopolymer impeller. Pump has built-in ejector complete with clean out port to clear blockages from nozzle. Convenient priming plug for ease of priming and air elimination. Ceramic-Carbon bellows mechanical seal ensures trouble-free operation.

JPF5A & JPF7A Pumps:

Rugged cast iron construction. Multistage convertible self-priming centrifugal pumps. End suction, top discharge arrangement with detachable ejector assembly for deep well applications and Technopolymer impellers. Convenient priming plug for ease of priming and air elimination. Ceramic-Carbon bellows mechanical seal ensures trouble-free operation.

JDF2A & JDF4A Pumps:

Rugged cast iron construction. Single-stage deep well self-priming centrifugal pumps. End suction, top discharge arrangement and Technopolymer impeller. Pump has separate deep well port for connection to Deep Well ejector kit. Convenient priming plug for ease of priming and air elimination. Ceramic-Carbon bellows mechanical seal ensures trouble-free operation.

JPS2A & JPS4A Pumps:

Corrosion resistant stainless steel construction. Single stage shallow well self-priming centrifugal pumps. End suction, top discharge arrangement and Technopolymer impeller. Ceramic-Carbon bellows mechanical seal ensures trouble-free operation.

Motors

All jet pump motors are totally enclosed and fan-cooled design for quiet operation and superior protection in harsh environments. Stainless steel motor shaft offers excellent corrosion resistance. Double, oversized greased ball bearings are maintenance-free sealed for life. All motors have built-in thermal overload protection and are capacitor-run, with no switches to fail. Drive end motor bearing protected by durable lip seal. Insulation class F, motor protection IP44, terminal box protection IP55.

Pumped Liquid

Only use on clean, non-viscous, non-aggressive, non-explosive liquids. Pump not to be used on pool water applications or hydrocarbon transfer (i.e. diesel, gasoline, etc).

Agency Approvals:

CSA -Std C22.2 No 108, No 77-95.

Mounting Position:

Shaft in horizontal position only for all pumps.

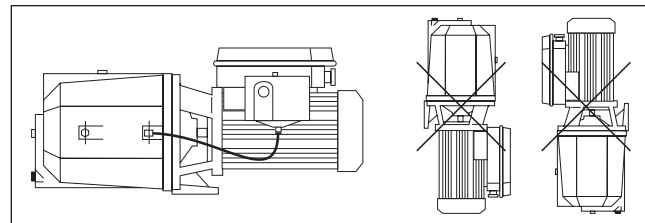

Electrical Data:

Model	Electrical Data					
	Voltage 60 Hz	kW Maximum	hp Nominal	S.F.	I Amps	Capacitor μF
JPF2A	115	0.65	1/3	1.75	6	40
JPF2A	230	0.65	1/3	1.75	3	10
JPF3A	115	0.85	1/2	1.6	7.5	20
JPF3A	230	0.85	1/2	1.6	3.8	12.5
JPF4A	115	1.10	3/4	1.5	10	64
JPF4A	230	1.10	3/4	1.5	5	16
JPF41A	115	1.31	1	1.4	12	80
JPF41A	230	1.31	1	1.4	6	20
JPF5A	230	1.70	1.5	1.3	8	31.5
JPF7A	230	2.40	2	1.2	11	40
JPS2A	115	0.88	1/2	1.6	7.6	50
JPS2A	230	0.82	1/2	1.6	3.7	12.5
JPS4A	115	1.6	1	1.4	13.6	80
JPS4A	230	1.53	1	1.4	7	20
JDF2A	115	0.75	1/2	1.6	7	50
JDF2A	230	0.75	1/2	1.6	3.4	12.5
JDF4A	115	0.88	3/4	1.5	8	64
JDF4A	230	0.88	3/4	1.5	4	16

JPF 2A, 3A, 4A, 41A* Shallow Well



*41A available in Canada

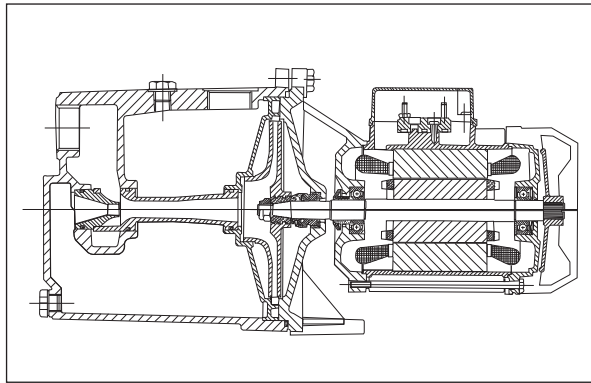

Materials: JPF 2A, 3A, 4A, 41A Shallow Well

Descriptions	Material
Motor Stool	Cast Iron
Shaft Seal	Carbon/Ceramic/NBR
O-Rings & Gaskets	NBR
Base Plate	Cast Iron
Pump Housing	Cast Iron
Impeller	Noryl©
Motor Shaft	Stainless Steel AISI 416
Tubing	Polyethylene
Diffuser	Noryl©
Venturi Tube and Nozzle	Noryl©

Note: Noryl© is a registered trademark of General Electric Company

JPF 5A, 7A Convertible*

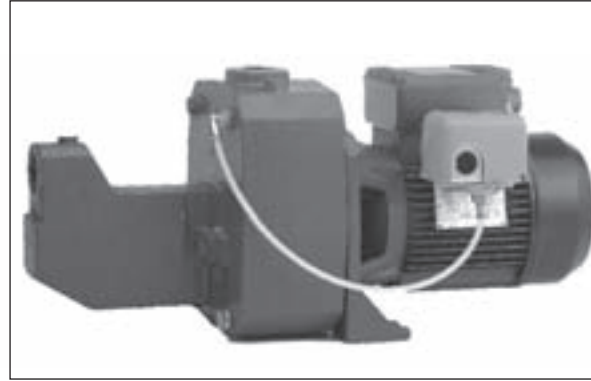

*Available in Canada

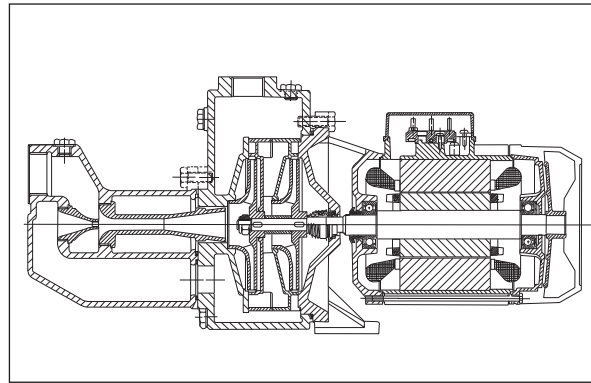

Materials: JPF 5A, 7A Convertible

Descriptions	Material
Motor Stool	Cast Iron
Shaft Seal	Carbon/Ceramic/NBR
Motor Shaft	Stainless Steel AISI 303
O-Rings & Gaskets	NBR
Base Plate	Cast Iron
Pump housing	Cast Iron
Impellers	Noryl©
Tubing	Polyethylene
Diffuser	Noryl©
Venturi Tube and Nozzle	Noryl©

Note: Noryl© is a registered trademark of General Electric Company

JPS 2A, 4A Shallow Well

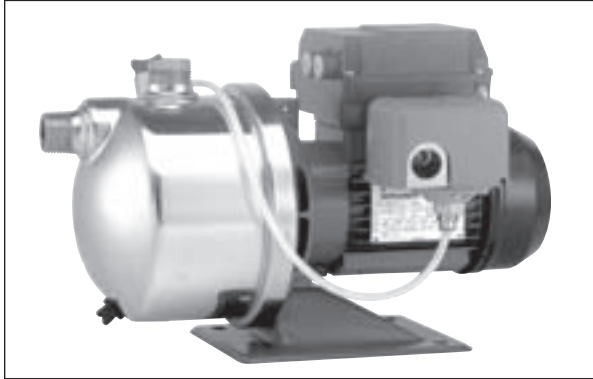

JDF 2A, 4A Deep Well

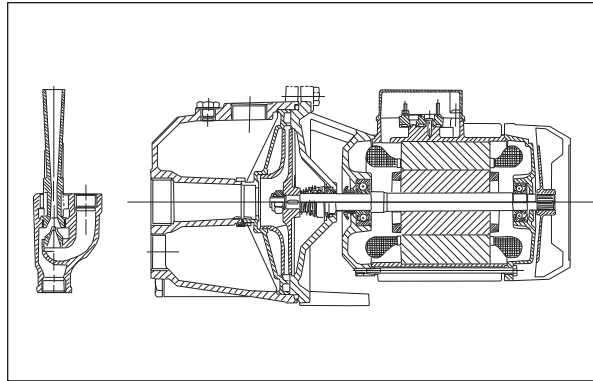
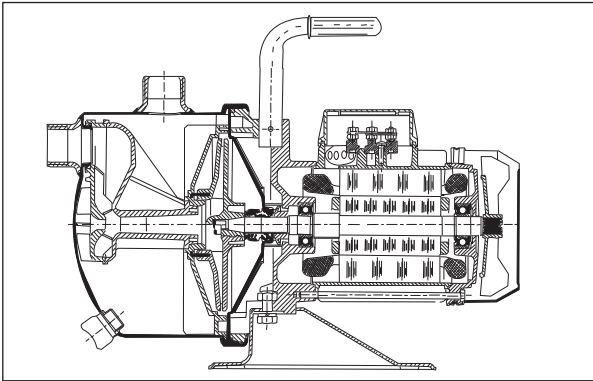
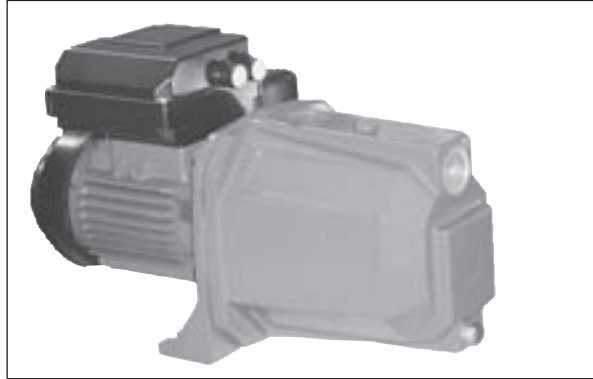

Materials: JPS 2A, 4A Shallow Well

Descriptions	Material
Motor Stool	Cast Iron
Shaft Seal	Carbon/Ceramic/NBR
O-Rings & Gaskets	NBR
Base Plate	Steel
Pump housing	Stainless Steel AISI 304
Impeller	Noryl®
Motor Shaft	Stainless Steel AISI 303
Tubing	Polyethylene
Seal cover	Stainless Steel AISI 304
Nozzle-Venturi Diffuser Assembly	Noryl®

Materials: JDF 2A, 4A Deep Well

Descriptions	Material
Motor Stool	Cast Iron
Shaft Seal	Ceramic/Ceramic/NBR
O-Rings & Gaskets	NBR
Base Plate	Cast Iron
Pump housing	Cast Iron
Impeller	Noryl®
Tubing	Polyethylene
Motor Shaft	Stainless Steel AISI 303
Diffuser	Noryl®
Venturi Tube	Noryl®

Note: Noryl® is a registered trademark of General Electric Company

Note: Noryl® is a registered trademark of General Electric Company

JPF3A Pump package*
Cast Iron



*Available in Canada

JPS2A Pump package*
Stainless Steel



*Available in Canada

Features and Benefits

Assembled jet-pump and tank package. Available with rugged 1/2 hp cast iron pump or corrosion-resistant stainless steel pump, mounted on a stainless steel, 6.3 gallon (24 litre) diaphragm tank. Package comes complete with pressure switch, gauge, hose and fittings, ready for installation.

Materials: JPF3A Pump Package

Descriptions	Material
Motor Stool	Cast Iron
Shaft Seal	Carbon/Ceramic/NBR
O-Rings and Gaskets	NBR
Base Plate	Cast Iron
Pump Housing	Cast Iron
Impeller	Noryl©
Motor Shaft	Stainless Steel AISI 416
Tubing	Polyethylene
Diffuser	Noryl©
Venturi Tube and Nozzle	Noryl©
Tank	Stainless Steel AISI304
Bladder	Butyl

Note: Noryl© is a registered trademark of General Electric Company

Materials: JPS2A Pump Package

Descriptions	Material
Motor Stool	Cast Iron
Shaft Seal	Carbon/Ceramic/NBR
O-Rings and Gaskets	NBR
Base Plate	Steel
Pump Housing	Stainless Steel AISI304
Impeller	Noryl©
Motor Shaft	Stainless Steel AISI 303
Tubing	Polyethylene
Seal Cover	Stainless Steel AISI304
Nozzle-Venturi Diffuser Assembly	Noryl©
Tank	Stainless Steel AISI304
Bladder	Butyl

Note: Noryl© is a registered trademark of General Electric Company

Dimensional Drawings

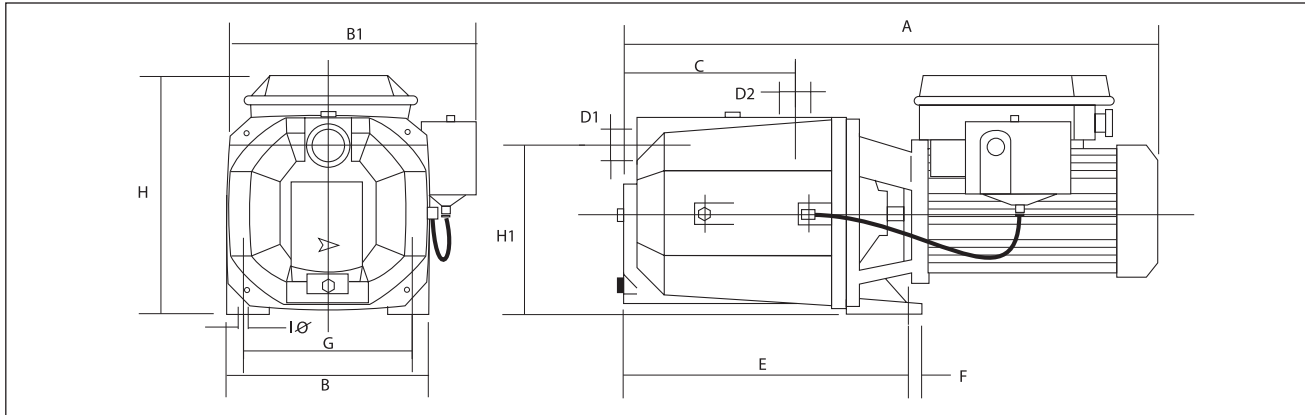

Dimensions and Weights

Pump Type	Motor Data				D1 Suction NPT	D2 Disch. NPT	Dimensions (inches)										Ship Wt. (lbs)	Ship Vol. (Cu Ft.)
	HP	S.F.	PH	Volts			A	B	B1	C	E	F	G	H	H1	IØ		
JPF2A	1/3	1.75	1	115 or 230	1"	1"	16.2	7.1	9.1	5.5	8.9	0.6	5.5	8.5	6.0	0.38	35	1.5
JPF3A	1/2	1.6	1	115 or 230	1"	1"	16.2	7.1	9.1	5.5	8.9	0.6	5.5	8.5	6.0	0.38	36	1.5
JPF4A	3/4	1.5	1	115 or 230	1"	1"	17.3	7.1	9.1	5.5	8.9	0.6	5.5	8.5	6.0	0.38	41	1.5
JPF41A	1	1.4	1	115 or 230	1"	1"	17.3	7.1	9.1	5.5	8.9	0.6	5.5	8.5	6.0	0.38	43	1.5

Shallow Well Performance Chart

Model	HP	Depth to Water	Discharge Pressure (PSI)							Shut-off (PSI)	Pressure Switch Settings (PSI)
			20	30	35	40	45	50	55		
			Capacities (U.S. gpm)*								
JPF2A	1/3	5	11	7	6	4	3	2		58	20-40
		10	10	7	6	4	3	2		56.5	
		15	9	7	6	4	3	2		54	
		20	7	6	5	4	3	2		51.5	
		25	5	4	3	2	1			49	
JPF3A	1/2	5	12	11	11	10	7	6	4	73.5	30-50
		10	10.5	10	10	9.5	7	6	4	71	
		15	9	8.5	8	8	7	6	4	68.5	
		20	7.5	7	7	7	6.5	6	4	66	
		25	5	5	5	5	4.5	4	4	63.5	
JPF4A	3/4	5	15	14	14	13	10	8.5	6	75.5	30-50
		10	13	12.5	12.5	12	10	8.5	6	73	
		15	11	11	10	10	10	8	6	70.5	
		20	9	9	9	8.5	8	7	6	68	
		25	6	6	6	6	5	5	5	65.5	
JPF41A	1	5	21	20.5	20	20	20	19	17.5	86.5	40-60
		10	19	18.5	18	18	17.5	17.5	17	84	
		15	16	16	16	15.5	15	15	14.5	81.5	
		20	13.5	13.5	13.5	13	13	12.5	12	79	
		25	10	10	10	9.5	9	9	8.5	76.5	

* Capacities given are for near-sea level installations.

Performance curves

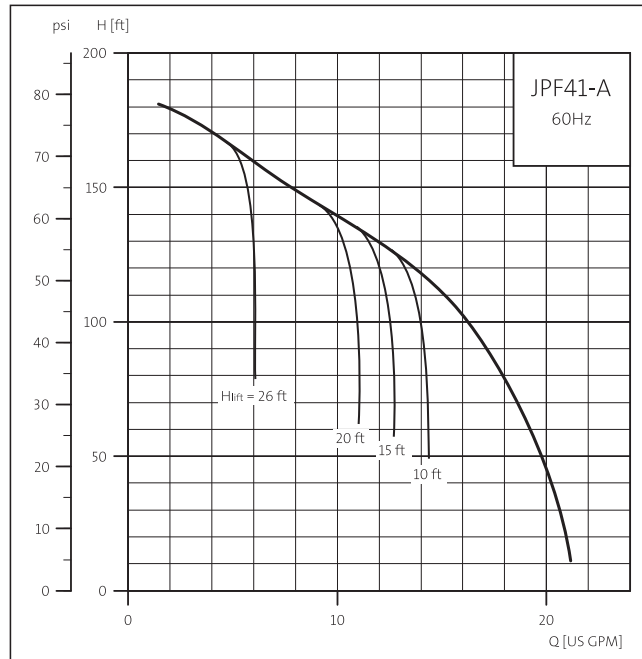
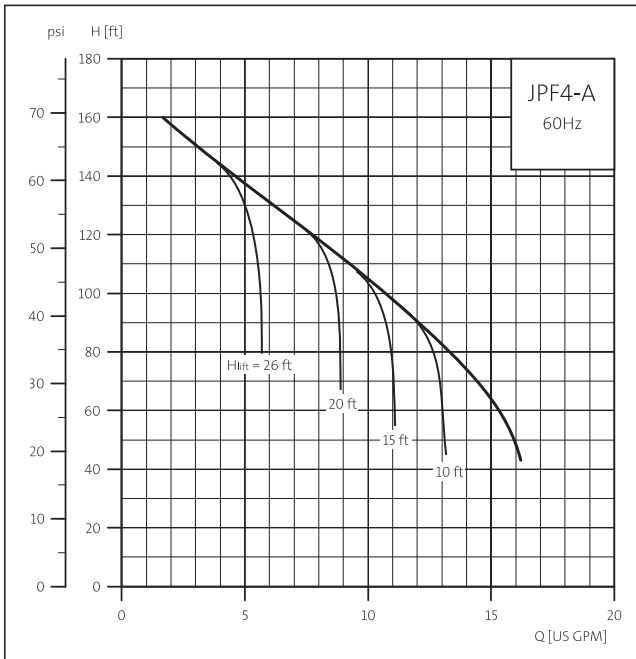
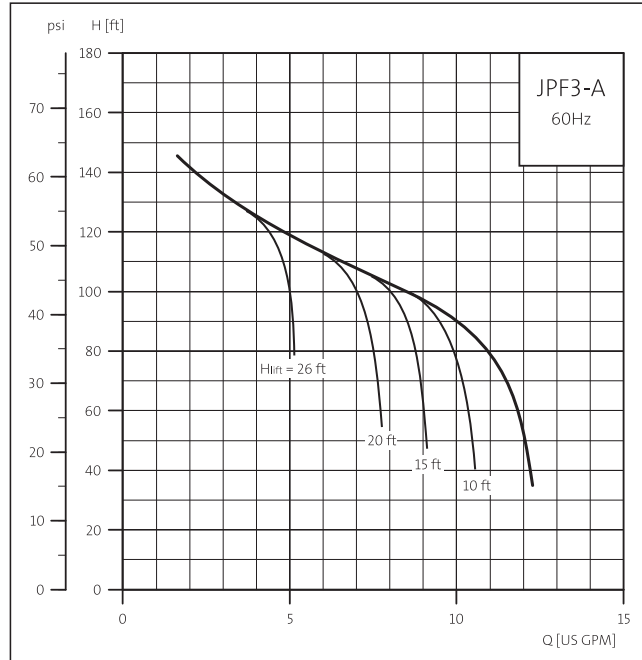
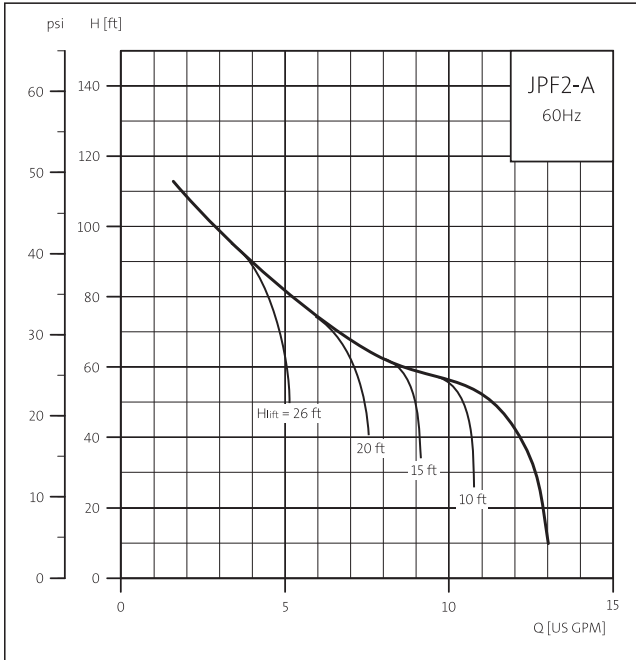

* Capacities given are for near-sea level installations.

Dimensional Drawings

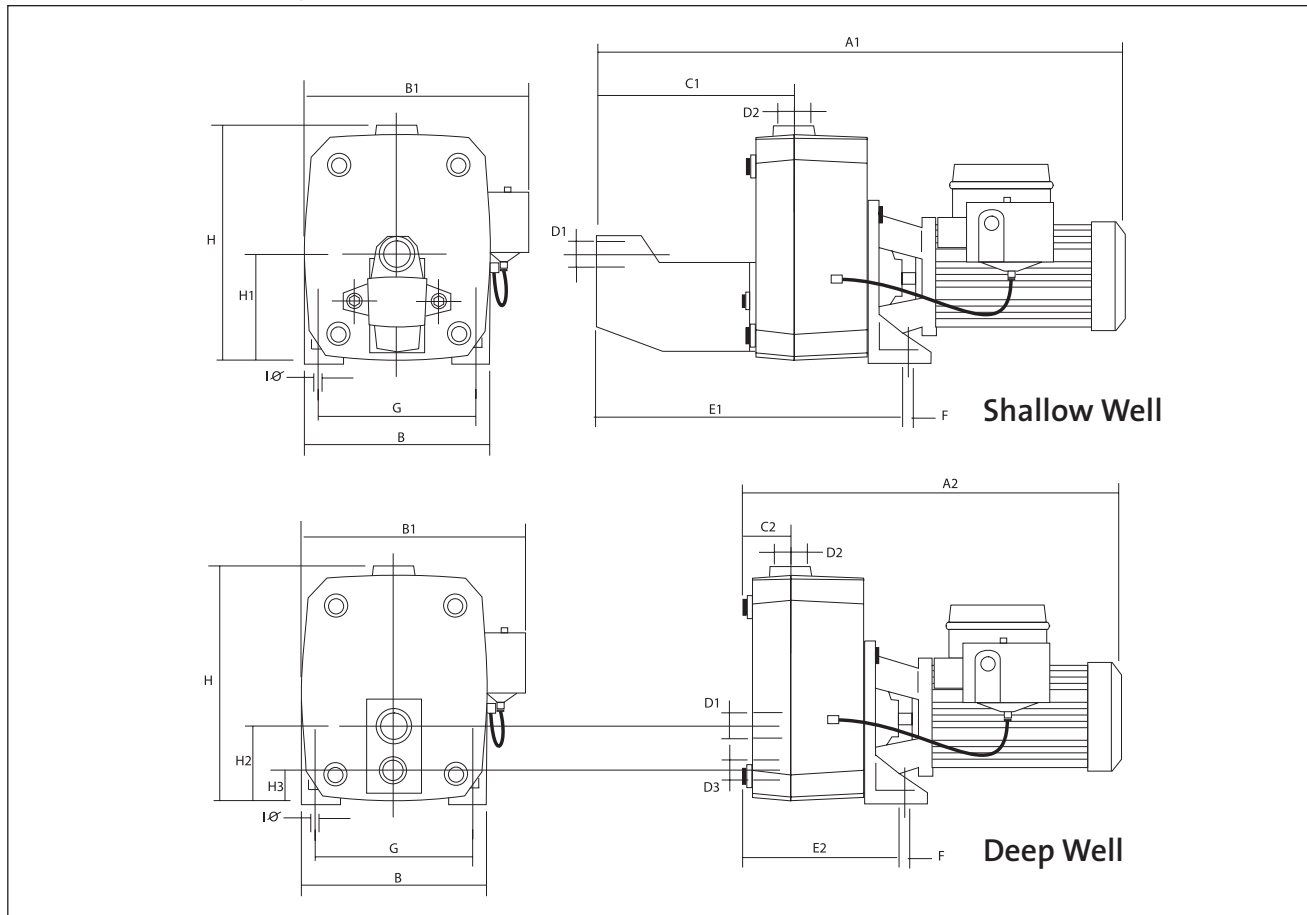

Dimensions and Weights

Pump Type	Motor Data				D1 Suction NPT	D2 Disch. NPT	D3 Re-turn NPT	Dimensions (inches)														Ship Wt. (lbs)	Ship Vol. (Cu Ft.)	
	HP	S.F.	PH	Volts				A1	A2	B	B1	C1	C2	E1	E2	F	G	H	H1	H2	H3			IØ
JPF5A	1.5	1.3	1	230	1-1/4"	1"	1"	22.0	15.3	8.3	11.0	8.7	2.0	13.8	7.8	0.78	5.7	10.0	6.2	4.3	2.1	0.44	70	1.9
JPF7A	2	1.2	1	230	1-1/4"	1"	1"	25.6	19.9	8.3	12.4	8.7	2.0	13.8	7.8	0.78	5.7	10.0	6.2	4.3	2.1	0.44	73	2.5

Conversion Instructions from Shallow Well to DeepWell*

Remove bolts and detach ejector nose from convertible jet pump. Connect suction (D1) and pressure (D3) port to deep well ejector.

* Requires separate ejector to suit specific suction lift needs.

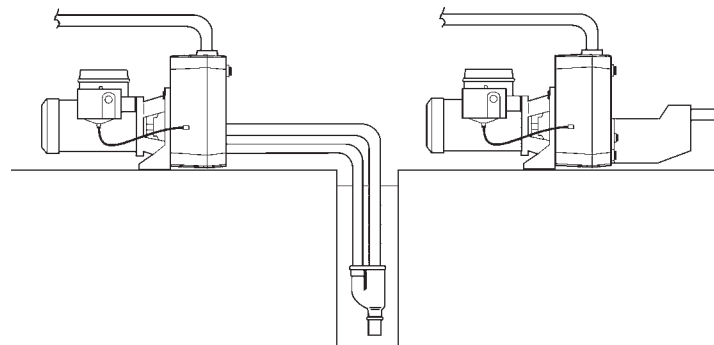

Shallow Well Performance Chart

Model	HP	Depth to Water	Discharge Pressure (PSI)						Shut-off (PSI)	Pressure Switch Settings (PSI)	
			20	30	35	40	45	50			55
			Capacities (U.S. gpm)*								
JPF5A	1-1/2	5	21	20.5	20	20	20	19	17.5	86.5	50-70
		10	19	18.5	18	18	17.5	17.5	17	84	
		15	16	16	16	15.5	15	15	14.5	81.5	
		20	13.5	13.5	13.5	13	13	12.5	12	79	
		25		10	10	9.5	9	9	8.5	76.5	
JPF7A	2	5	34	34	33.5	33	32.5	30	27	88	50-80
		10	28.5	28	28	28	27.5	27	26	85.7	
		15	24	24	23.5	23.5	23	22.5	22	83	
		20	20	20	19.5	19.5	19.5	19	19	80	
		25		15.5	15.5	15.5	15	15	15	77.8	

* Capacities given are for near-sea level installations.

Performance Curves

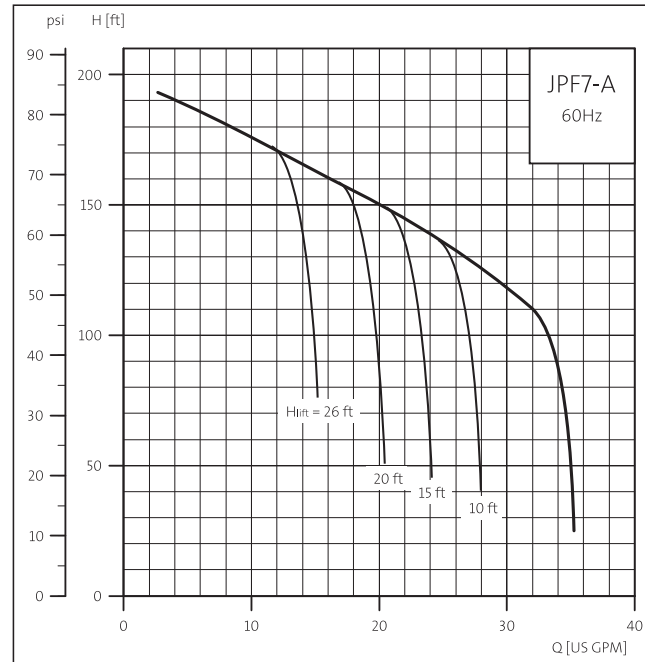
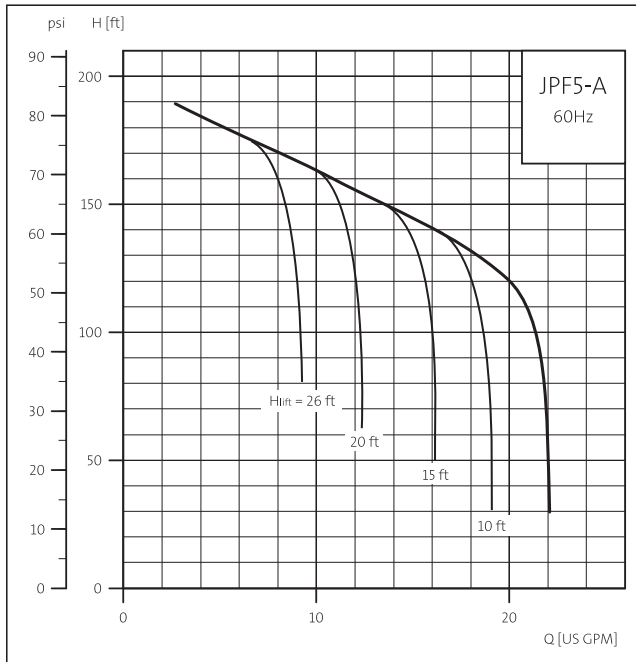

* Capacities given are for near-sea level installations.

Deep Well Performance Chart

Model	Ejector Type	Discharge Pressure (psig)	Depth to water (feet)									
			30	40	50	60	70	80	90	100	120	140
			Capacities U.S. gpm*									
JPF5A	E20	45	14.9	13.2	11.4	9.7	7.8	6.0				
		50	12.1	10.2	8.4	6.7	3.9					
		60	9.6	7.3	5.3	3.7						
		65	6.0	4.1	2.1							
		75	2.9	1.0								
	E25	50			10.1	8.9	8.0	6.2	4.8			
		60			8.0	6.8	5.8	4.1	3.0			
		65			6.0	5.4	1.0					
		75			5.3	3.1						
	E30	80			2.5	1.7						
		50					7.4	6.7	5.9	5.0	3.2	1.5
		60					6.2	5.5	4.8	4.1	2.7	1.2
65						5.1	4.5	3.9	3.1	1.4		
75						4.0	3.5	2.9	2.0			
JPF7A	E20	80				3.1	2.7	2.2	1.8			
		50	17.5	15.8	14.3	11.7	8.0	5.5	1.5			
		60	14.2	12.5	10.6	8.5	6.0	3.6				
		65	11.0	9.8	7.1	5.0	2.1					
		75	7.8	6.0	3.6	1.7						
	E25	80	4.2	2.6								
		50			11.9	10.5	9.3	8.0	6.1	3.8	1.0	
		60			9.7	8.4	7.1	5.8	4.3	3.0		
		65			7.6	6.3	5.2	4.0	2.2			
		75			5.5	4.3	3.4	2.3				
	E30	90			3.6	2.6	1.8					
		65					7.9	6.9	6.1	5.1	3.9	1.5
		75					6.3	5.6	5.1	4.3	2.8	1.0
		80					5.3	4.6	4.1	3.5	2.0	
		90					4.3	3.7	3.2	2.6	1.2	
					3.3	2.9	2.4	1.9				

* Capacities given are for near-sea level installations.

Dimensional Drawings

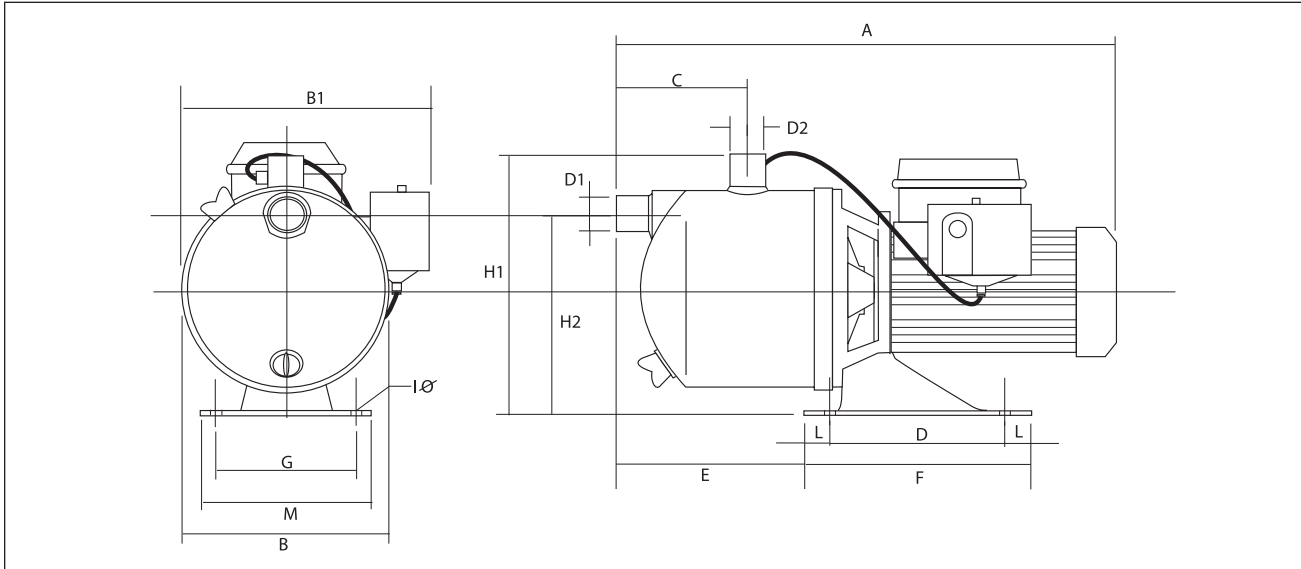

Dimensions and Weights

Pump Type	Motor Data				D1 Suction NPT	D2 Disch. NPT	Dimensions (inches)										Ship Wt. (lbs)	Ship Vol. (Cu Ft.)	
	HP	S.F.	PH	Volts			A	B	B1	C	E	F	G	H1	H2	L			IØ
JPS2A	1/2	1.6	1	115 or 230	1"	1"	14.8	7.5	9.3	3.7	4.8	7.1	4.3	9.1	7.0	0.83	0.42	24	1.5
JPS4A	1	1.6	1	115 or 230	1"	1"	15.6	7.5	9.3	3.7	4.8	7.1	4.3	9.1	7.0	0.83	0.42	31	1.5

Shallow Well Performance Chart

Model	HP	Depth to Water	Discharge Pressure (PSI)							Shut-off (PSI)	Pressure Switch Settings (PSI)
			20	30	35	40	45	50	55		
			Capacities (U.S. gpm)*								
JPS2A	1/2	5	15	13	11	8	6	4	2	62	30-50
		10	14	12	10	7	5	3	1	59.5	
		15	13	11	9	6	4	2		57	
		20	10	10	8	5	3	1		54.5	
		25	8	8	7	4	2			52	
JPS4A	1	5	30	27	22	17	14	10	7	68	30-50
		10	26	23	21	16	13	9	6	65.5	
		15	22	21	20	15	12	8	5	63	
		20	18	17	16	14	11	7	4	60.5	
		25	14	13	13	12	11	6	3	58	

* Capacities given are for near-sea level installations.

Performance curves

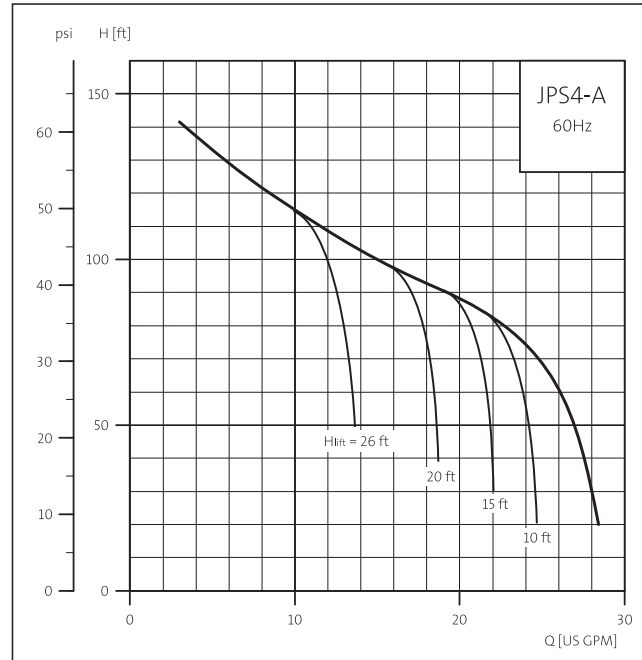
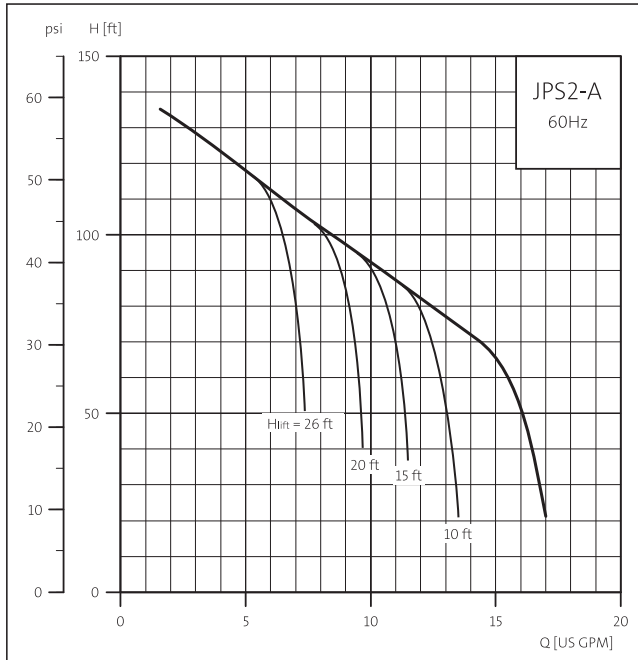

* Capacities given are for near-sea level installations.

Dimensional Drawings

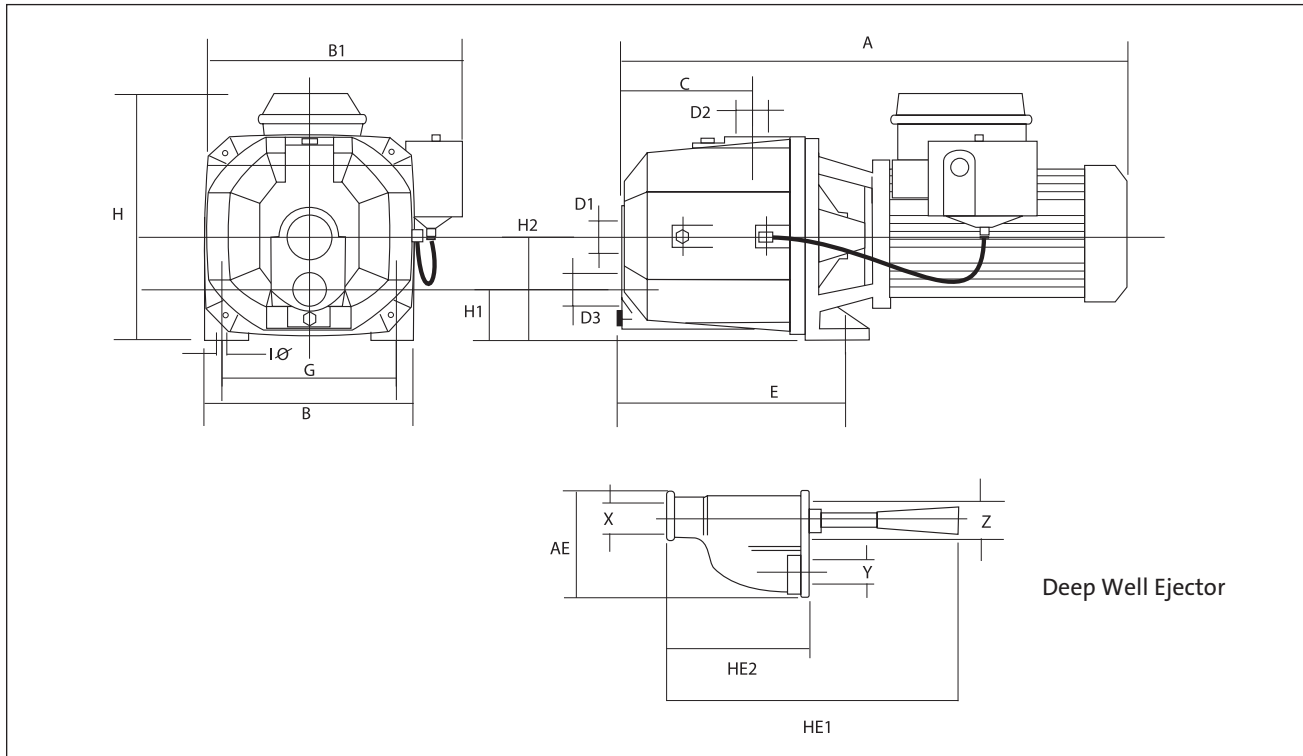

Deep Well Ejector

Dimensions and Weights

Pump Type	Motor Data				D1 Suction NPT	D2 Disch. NPT	D3 Return NPT	Dimensions (inches)										Ship Wt. (lbs)	Ship Vol. (Cu Ft.)
	HP	S.F.	PH	Volts				A	B	B1	C	E	IØ	G	H	H1	H2		
JDF2A	1/2	1.6	1	115 or 230	1.25"	1"	1"	15.2	7.1	9.1	3.5	8.0	0.38	5.5	8.9	1.9	3.6	36	1.5
JDF4A	3/4	1.5	1	115 or 230	1.25"	1"	1"	15.2	7.1	9.1	3.5	8.0	0.38	5.5	8.9	1.9	3.6	37	1.5

Deep Well Ejector Dimensions

AE	HE1	HE2	X	Y	Z
3.8	11.6	5.63	1" NPT	1" NPT	1.25" NPT

Nozzle and Venturi Combinations for Grundfos Deep Well Jet Pumps

Ejector Type	Nozzle Size		Venturi Size	
	mm.	Inches	mm.	Inches
E20	6	0.24	12	0.48
E25	6	0.24	10	0.40
E30	6	0.24	8.5	0.34

Performance Chart

Model	Ejector Type	Discharge Pressure (psig)	Depth to water (feet)					
			30	40	50	60	70	80
			Capacities U.S. gpm*					
JDF2A	E20	20	12.0	7.0				
		30	4.6					
		35						
		45						
		SHUTOFF (psi)						
	E25	20	10.4	8.5	6.5			
		30	5.8	4.5	2.9			
		35	3.8	2.5	1.1			
		45	1.0					
		SHUTOFF (psi)	0.8	0.7	0.7			
	E30	20	8.3	7.1	6.2	4.1	3.3	
		30	5.9	4.9	4.0	2.6	1.8	
		35	4.8	3.8	2.9	1.6		
		45	2.9	2.0	1.3			
		50	2.0	1.25				
	SHUTOFF (psi)	1.0	0.9	0.9				
JDF4A	E20	20	18	9.0	1.6			
		30	8.3	2.7	0.8			
		35	3.4	1.0				
		45						
		SHUTOFF (psi)						
	E25	20	13.3	11.1	8.7			
		30	8.7	6.8	4.8			
		35	6.6	4.6	2.9			
		45	2.6	1.0				
		SHUTOFF (psi)	0.8	0.8	0.7			
	E30	30		6.0	5.4	4.4	3.5	2.2
		35		5.3	4.3	3.3	2.6	1.8
		45		3.1	2.3	1.6	1.2	
		50		2.2	1.5	1.0	0.5	
		SHUTOFF (psi)		1.2	1.0	1.0	0.9	

* Capacities given are for near-sea level installations.

Product Guide

JPF3A Pump Package* Cast Iron Body Construction

* Available in Canada

Dimensional Drawings

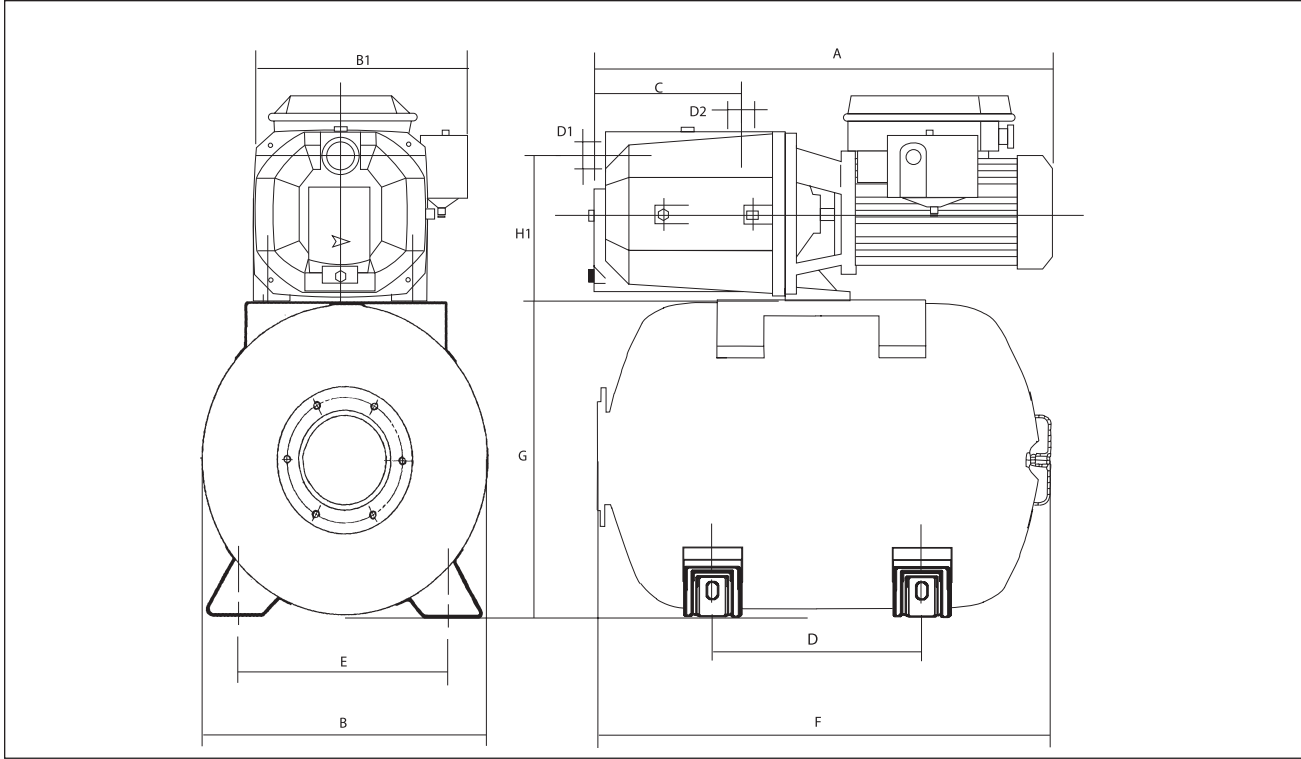

Dimensions and Weights

Pump Type	Motor Data				D1 Suction NPT	D2 Disch. NPT	Dimensions (inches)									Ship Wt. (lbs)	Ship Vol. (Cu Ft.)
	HP	S.F.	PH	Volts			A	B	B1	C	D	E	F	G	H1		
JPF3A	1/2	1.6	1	115 or 230	1"	1"	1.2	11.9	9.1	5.5	9.1	7.1	15.2	11.9	6.0	7.0	5.0

Shallow Well Performance Chart

Model	HP	Depth to Water	Discharge Pressure (PSI)							Shut-off (PSI)	Pressure Switch Settings (PSI)
			20	30	35	40	45	50	55		
			Capacities (U.S. gpm)*								
JPF3A	1/2	5	12	11	11	10	7	6	4	73.5	30-50
		10	10.5	10	10	9.5	7	6	4	71	
		15	9	8.5	8	8	7	6	4	68.5	
		20	7.5	7	7	7	6.5	6	4	66	
		25	5	5	5	5	4.5	4	4	63.5	

* Capacities given are for near-sea level installations.

Product Guide

JPS2A Pump Package* Stainless Steel Body Construction

*Available in Canada

Dimensional Drawings

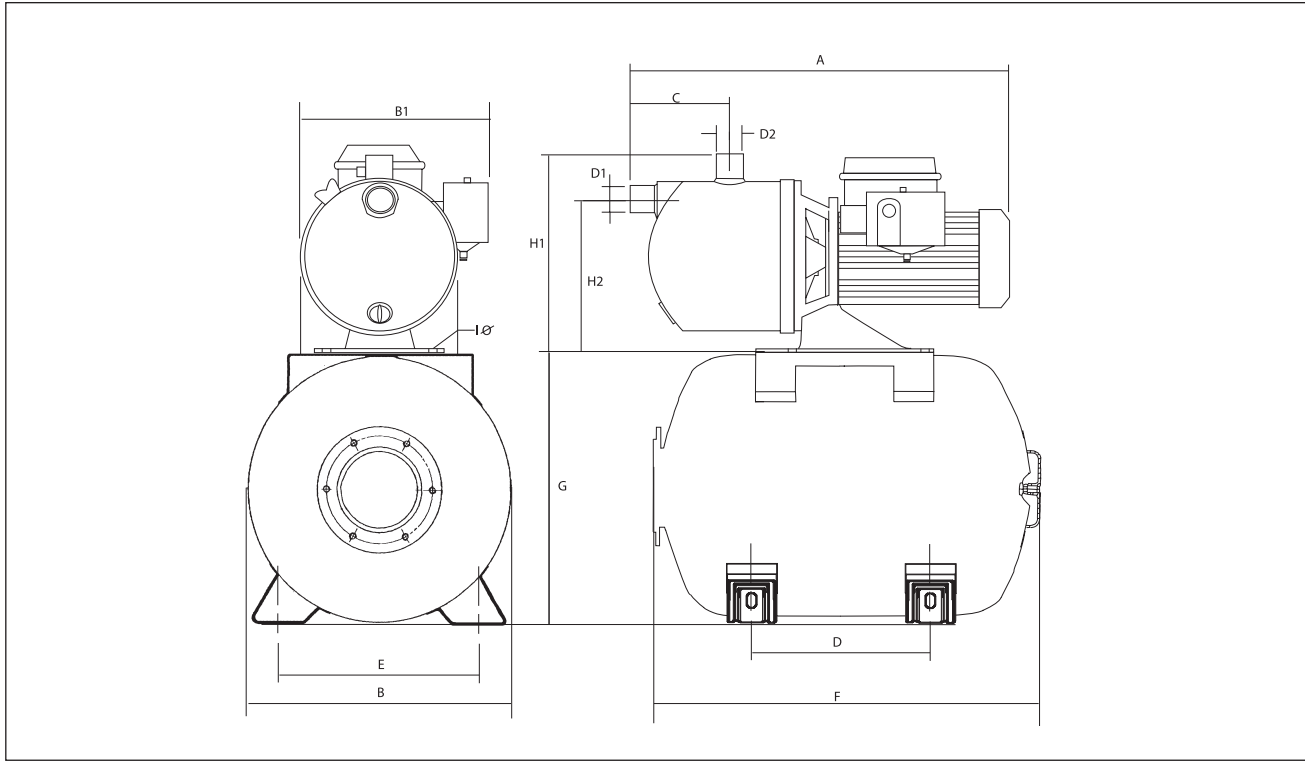

Dimensions and Weights

Pump Type	Motor Data				D1 Suction NPT	D2 Disch. NPT	Dimensions (inches)										Ship Wt. (lbs)	Ship Vol. (Cu Ft.)
	HP	S.F.	PH	Volts			A	B	B1	C	E	F	G	H1	H2	IØ		
JPS2A	1/2	1.6	1	115 or 230	1"	1"	14.8	11.9	9.3	3.7	7.1	15.2	11.9	8.5	6.0	0.38	45.0	5.0

Shallow Well Performance Chart

Model	HP	Depth to Water	Discharge Pressure (PSI)							Shut-off (PSI)	Pressure Switch Settings (PSI)
			20	30	35	40	45	50	55		
			Capacities (U.S. gpm)*								
JPS2A	1/2	5	15	13	11	8	6	4	2	62	30-50
		10	14	12	10	7	5	3	1	59.5	
		15	13	11	9	6	4	2		57	
		20	10	10	8	5	3	1		54.5	
		25	8	8	7	4	2			52	

* Capacities given are for near-sea level installations.

Submittal data sheet



Company name: _____
Prepared by: _____
Phone number: () - _____
Fax number: () - _____
Date: _____ Page 1 of: _____
Quote number: _____

Client Information

Project title: _____	Client name: _____
Reference number: _____	Client number: _____
Client contact: _____	Client phone no: () - _____

Location Information

For: _____	Unit: _____
Site: _____	Service: _____
Address: _____	City: _____ State: _____ Zip Code: _____

Technical Data

Flow (GPM) _____
Head (Ft) _____
Motor _____
Max Fluid Temp _____
Min Fluid Temp _____
Max Working Pressure _____
Min Required Inlet Pressure _____
Connection Type and Size _____

Motor Information

HP: _____
Phase: _____
Voltage: _____
Enclosure: _____

Pump Information

Model Information from Type Key and Codes: _____	
Quantity Required: _____	Example: MQ 3-35
Minimum required flow: _____	NPSH required at duty point: _____
Product Guide additional information pages	
Materials page number: _____	Performance curve page number: _____
Technical data page number: _____	Motor data page number: _____

Custom-built pump information (optional): _____

Additional Information



BE > THINK > INNOVATE >

Being responsible is our foundation
Thinking ahead makes it possible
Innovation is the essence



L-DWS-PG-01 0809 **US**
Repl. 0409
© 2008, 2009 Grundfos Pumps Corp.

Subject to alterations

Grundfos Pumps Corporation
17100 W. 118th Terrace
Olathe, KS 66061
Telephone 913 227 3400
Fax: 913 227 3500

www.grundfos.com

Grundfos Canada, Inc.
2941 Brighton Road
Oakville, Ontario L6H 6C9 Canada
Telephone: 905 829 9533
Fax: 905 829 9512

Bombas Grundfos de Mexico, S.A. de C.V.
Boulevard TLC #15
Parque Stiva Aeropuerto
Apodaca, N.L. 66600 Mexico
Telephone: 52 81 8144 4000
Fax: 52 81 8144 4010

