

Product information presented here reflects conditions at time of publication. Consult factory regarding discrepancies or inconsistencies.



PUMP COMPANY

Zoeller Family of Water Solutions™

MAIL TO: P.O. BOX 16347 • Louisville, KY 40256-0347
SHIP TO: 3649 Cane Run Road • Louisville, KY 40211-1961
(502) 778-2731 • 1 (800) 928-PUMP • FAX (502) 774-3624

visit our web site:
www.zoeller.com

PREASSEMBLED 24" x 24" SEWAGE SYSTEMS

Complete and Job-Ready for Fast Installation!

912 SEWAGE SYSTEMS INCLUDE:

- (1) 2" solids sewage ejector
- (1) 24" x 24" poly molded basin
- (1) PSF cover with 2V2D
- Internal 2" PVC discharge pipe

PUMP FEATURES:

- Cast iron construction (264/266)
- Thermoplastic construction (211)
- Automatic or piggyback configuration available
- Full 2" solids capacity
- Thermal overload protection
- Non-clogging vortex impeller

BASIN FEATURES:

- 24" depth for easier installation in troublesome areas
- 41-gallon capacity (exceeds 18 x 30)
- 25-gallon capacity below 4" inlet
- Vertical support ribs help eliminate stuck float switches
- Anti-flotation device helps to eliminate basin from "floating"
- 360° molded handle (acts as secondary AFD)
- (1) 4" pre-drilled inlet (flex-coupling provided by others)
- (7) additional flat areas for inlet installation (field drilled)
- Molded torque stops for added pump support
- One-piece molded PSF cover with integrated molded foam seal
- Ribbed reinforced cover to provide additional strength and stability
- Threaded 2" vent and 2" discharge piping connections
- Stainless steel cover bolts and hardware
- High water alarm available on certain packages
- Stackable for storage/shipping



912-0116 Shown

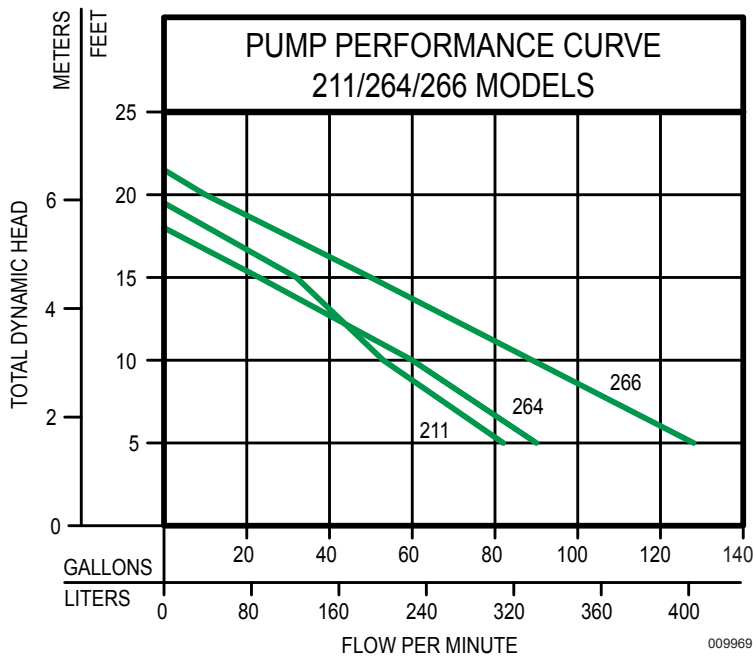

TOTAL DYNAMIC HEAD / FLOW PER MINUTE

MODELS		211		264		266	
Feet	Meters	Gal.	Liters	Gal.	Liters	Gal.	Liters
5	1.5	82	310	90	341	128	484
10	3.1	53	201	60	227	89	337
15	4.6	32	121	23	87	50	189
20	6.1	-	-	-	-	10	38
Shut-off Head:		19.5 ft.(5.9m)		18 ft.(5.5m)		21.5 ft.(6.6m)	

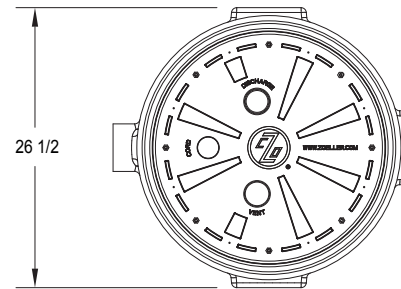

PUMP SPECIFICATIONS:

- 0.4 HP (211/264) or 1/2 HP (266) available
- 115 Volts
- 2" NPT discharge with 2" solids capacity
- Refer to **FM1784 (211)**, **FM1495 (264)** or **FM0390 (266)** for additional specifications

BASIN SPECIFICATIONS:

- Poly molded basin with PSF cover
- 41-gallon capacity (25 gallons below inlet)
- (1) 4" inlet (predrilled, coupling by others)
- Integral foam seal
- Stainless steel bolt kit

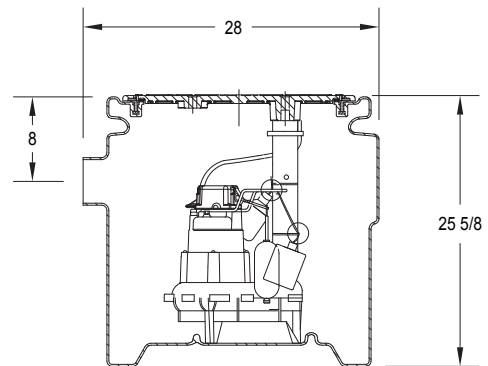

SK2694

Part Number	Pump	Description	Weight (lbs)
912-0112	M211	Automatic 211 - Poly Molded Basin w/ 2V2D PSF Simplex Cover	50
912-1112	"	Automatic 211 - Poly Molded Basin w/ 2V2D PSF Simplex Cover includes (1) 10-1494 Indoor Alarm	54
912-0113	BN211	Piggyback Float 211 - Poly Molded Basin w/ 2V2D PSF Simplex Cover	50
912-1113	"	Piggyback Float 211 - Poly Molded Basin w/ 2V2D PSF Simplex Cover includes (1) 10-1494 Indoor Alarm	54
912-0114	M264	Automatic 264 - Poly Molded Basin w/ 2V2D PSF Simplex Cover	73
912-1114	"	Automatic 264 - Poly Molded Basin w/ 2V2D PSF Simplex Cover includes (1) 10-1494 Indoor Alarm	75
912-0115	BN264	Piggyback Float 264 - Poly Molded Basin w/ 2V2D PSF Simplex Cover	73
912-1115	"	Piggyback Float 264 - Poly Molded Basin w/ 2V2D PSF Simplex Cover includes (1) 10-1494 Indoor Alarm	75
912-0116	M266	Automatic 266 - Poly Molded Basin w/ 2V2D PSF Simplex Cover	76
912-1116	"	Automatic 266 - Poly Molded Basin w/ 2V2D PSF Simplex Cover includes (1) 10-1494 Indoor Alarm	78
912-0117	BN266	Piggyback Float 266 - Poly Molded Basin w/ 2V2D PSF Simplex Cover	76
912-1117	"	Piggyback Float 266 - Poly Molded Basin w/ 2V2D PSF Simplex Cover includes (1) 10-1494 Indoor Alarm	78

JOB READY FOR EASY INSTALLATION



WARNING TO REDUCE THE RISK OF ELECTRICAL SHOCK A PROPERLY GROUNDED RECEPTACLE OF GROUNDING TYPE SHALL BE INSTALLED AND PROTECTED BY A GROUND FAULT CIRCUIT INTERRUPTER (GFCI) IN ACCORDANCE WITH NATIONAL ELECTRICAL CODE AND LOCAL CODES. DO NOT REMOVE GROUND PIN FROM PLUG.

RESERVE POWERED DESIGN

For unusual conditions a reserve safety factor is engineered into the design of every Zoeller pump.