

**NOTICE TO INSTALLER: Instructions must remain with installation.**

**SECTION: 6.10.064**

*Your Peace of Mind is Our Top Priority®*

FM2408

1212

Supersedes

0310

Product information presented here reflects conditions at time of publication. Consult factory regarding discrepancies or inconsistencies.



**PUMP COMPANY**

*Zoeller Family of Water Solutions™*

**MAIL TO:** P.O. BOX 16347 • Louisville, KY 40256-0347  
**SHIP TO:** 3649 Cane Run Road • Louisville, KY 40211-1961  
(502) 778-2731 • 1 (800) 928-PUMP • FAX (502) 774-3624

**visit our web site:**  
**www.zoeller.com**

Patent No. 7,203,976  
Other Patents Pending

MODEL NO. \_\_\_\_\_  
DATE CODE: \_\_\_\_\_  
DATE INSTALLED: \_\_\_\_\_

**QWIK JON® ULTIMA 203 SYSTEMS  
INSTALLATION INSTRUCTIONS  
PREINSTALLATION CHECKLIST**

1. Inspect all materials. Occasionally, products are damaged during shipment. If the unit is damaged, contact your dealer before using. **Do Not** remove the test plugs from the pump.
2. Carefully read all the literature provided to familiarize yourself with specific details regarding installation and use before attempting the installation. These materials should be retained for future reference.



**WARNING**

**SEE BELOW FOR LIST OF WARNINGS**

1. **Make sure there is a properly grounded receptacle available.** All pumps are furnished with provisions for proper grounding to protect you against the possibility of electrical shock. **(SEE WARNING BELOW)**
2. Make certain that the receptacle is within the reach of the pump's power supply cord. **DO NOT USE AN EXTENSION CORD.** Extension cords that are too long or too light do not deliver sufficient voltage to the pump motor. But, more important, they could present a safety hazard if the insulation were to become damaged or the connection end were to fall into the sump.
3. **Make sure the pump electrical supply circuit is equipped with fuses or circuit breakers of proper capacity.** A separate branch circuit is recommended, sized according to local electrical code for the current shown on the pump nameplate.
4. **Testing for ground.** As a safety measure, each electrical outlet should be checked for ground using a circuit analyzer which will indicate if the power, neutral and ground wires are correctly connected to your outlet. If they are not, call a qualified licensed electrician.
5. **For Added Safety.** Use of a residual current device with an operating current not higher than 30 mA is recommended.
6. **FOR YOUR PROTECTION, ALWAYS DISCONNECT PUMP FROM ITS POWER SOURCE BEFORE HANDLING. DO NOT UNDER ANY CIRCUMSTANCES REMOVE THE GROUND PIN.** The 3-prong plug must be inserted into a mating 3-prong grounded receptacle. If the installation does not have such a receptacle, it must be changed to the proper type, wired and grounded in accordance with the local electrical code and all applicable local codes and ordinances.
7. **"Risk of electrical shock"** Do not remove power supply cord and strain relief or connect conduit directly to the pump.
8. Installation and servicing of electrical circuits and hardware should be performed by a qualified licensed electrician.
9. Pump installation and servicing should be performed by a qualified person.
10. Risk of electric shock - These pumps have not been investigated for use in swimming pool and marine areas.
11. If the supply cable is damaged, it must be replaced by the manufacturer or its technical service or similarly qualified persons in order to avoid a hazard.
12. The appliance is not intended for use by persons (including children) with reduced physical, sensory or mental capabilities, or lack of experience and knowledge, unless they have been given supervision or instruction concerning use of the appliance by a person responsible for their safety.
13. Pump is not intended for potable water due to possible contamination by oil contained in the pump.

**CAUTION**

**SEE BELOW FOR LIST OF CAUTIONS**

1. The Qwik Jon® Ultima is fitted with a specially-designed grinder pump and is capable of pumping fecal matter, toilet paper and sanitary articles which may be accidentally dropped into the toilet. It is not recommended to flush such foreign objects as they might clog the sanitary sewer.
2. Check to be sure your power source is adequate to handle the amperage requirements of the motor as indicated on the pump or unit I.D. tag.
3. All plumbing (discharge and vent lines) must be installed to meet local codes. **Unit must be vented. Do not use an automatic plumbing vent device.**
4. Maximum operating temperature must not exceed 130°F.
5. Do not use cleaning products containing bleach in the toilet tank, toilet or attached fixtures as they will degrade the pump seals.

P/N 018509

**NOTES**

**SEE BELOW FOR LIST OF NOTES**

1. Repair and service should be performed by an Authorized Service Station only (consult factory).
2. Recommended for installations up to 20' total dynamic head. Consult factory if installation is above 15' vertical height in 1" pipe. Mini-Grinder Pump is designed for use in Qwik Jon® Ultima units only. It is not designed for use in any other application.
3. Pumps with the "UL" mark and/or the "US" mark are tested to UL Standard UL778. CSA Certified pumps are certified to CSA Standard C22.2 No. 108. Qwik Jon® Ultima units only. It is not designed for use in any other application.
4. All fixtures connecting to the system must be on the same floor level.

**REFER TO WARRANTY ON PAGE 2.**

## LIMITED WARRANTY

Manufacturer warrants, to the purchaser and subsequent owner during the warranty period, every new product to be free from defects in material and workmanship under normal use and service, when properly used and maintained, for a period of one year from date of purchase by the end user, or 18 months from date of original manufacture of the product, whichever comes first. Parts that fail within the warranty period, one year from date of purchase by the end user, or 18 months from the date of original manufacture of the product, whichever comes first, that inspections determine to be defective in material or workmanship, will be repaired, replaced or remanufactured at Manufacturer's option, provided however, that by so doing we will not be obligated to replace an entire assembly, the entire mechanism or the complete unit. No allowance will be made for shipping charges, damages, labor or other charges that may occur due to product failure, repair or replacement.

This warranty does not apply to and there shall be no warranty for any material or product that has been disassembled without prior approval of Manufacturer, subjected to misuse, misapplication, neglect, alteration, accident or uncontrollable act of nature; that has not been installed, operated or maintained in accordance with Manufacturer's installation instructions; that has been exposed to outside substances including but not limited to the following: sand, gravel, cement, mud, tar, hydrocarbons, hydrocarbon derivatives (oil,

gasoline, solvents, etc.), or other abrasive or corrosive substances, wash towels or feminine sanitary products, or any other abusive entity, etc. in all pumping applications. The warranty set out in the paragraph above is in lieu of all other warranties expressed or implied; and we do not authorize any representative or other person to assume for us any other liability in connection with our products.

Contact Manufacturer at, 3649 Cane Run Road, Louisville, Kentucky 40211, Attention: Customer Support Department to obtain any needed repair or replacement of part(s) or additional information pertaining to our warranty.

**MANUFACTURER EXPRESSLY DISCLAIMS LIABILITY FOR SPECIAL, CONSEQUENTIAL OR INCIDENTAL DAMAGES OR BREACH OF EXPRESSED OR IMPLIED WARRANTY; AND ANY IMPLIED WARRANTY OF FITNESS FOR A PARTICULAR PURPOSE AND OF MERCHANTABILITY SHALL BE LIMITED TO THE DURATION OF THE EXPRESSED WARRANTY.**

Some states do not allow limitations on the duration of an implied warranty, so the above limitation may not apply to you. Some states do not allow the exclusion or limitation of incidental or consequential damages, so the above limitation or exclusion may not apply to you.

This warranty gives you specific legal rights and you may also have other rights which vary from state to state.

## HELPFUL HINTS FOR EASY INSTALLATION

1. Read all instructions before beginning installation.
2. Be sure the floor is level within 1/8".
3. Install vent pipe seals with flange side of seal on outside of lid.
4. Use soapy water to lubricate all seals to aid installation.
5. Install rubber coupling/union in vent line to aid disassembly.
6. Do not over-torque toilet mounting screws.
7. Do not use an automatic plumbing vent device.
8. Obtain model number and date code, and record information in the space provided on the front of this manual. Refer to this information when calling the factory.

## DO'S AND DON'T'S FOR INSTALLING UNIT

1. DO read all installation material with the unit.
2. DO inspect unit for any visible damage caused by shipping. Contact dealer if unit appears to be damaged.

## DO'S AND DON'T'S, CONTINUED

3. DO clean all visible debris from the unit.
4. DO always disconnect pump from power source before handling. DO always connect to a separately protected and properly grounded ground fault protected circuit. DO NOT ever cut, splice or damage power cord. DO NOT carry or lift pump by its power cord. DO NOT use an extension cord.
5. DO install a ball or gate valve and a union in the discharge line downstream of the check valve.
6. DO test pump immediately after installation to be sure that the system is working properly.
7. DO review all applicable local codes and verify that the installation conforms to each of them.
8. We DO NOT recommend this product be connected to utilities other than those found in a normal bathroom application. Washing machines and dishwashers are examples of equipment that we DO NOT recommend.
9. DO inspect and test system for proper operations at least every 3 months.

## TYPICAL PIPING CONFIGURATIONS

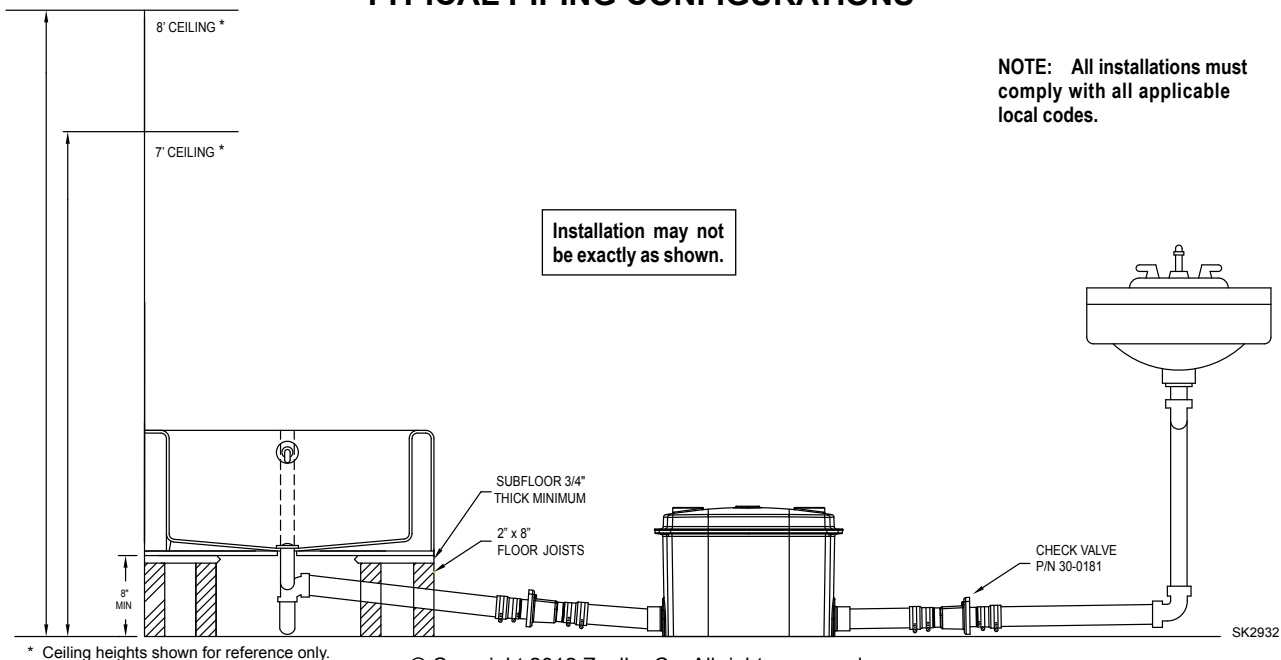

## SERVICE PARTS

<b>QWIK JON® ULTIMA 203</b>		<b>203-A</b>	<b>203-A (PREMIUM)</b>
		9/06 thru Current	5/12 thru Current
Item	Description	Part No.	
1	Qwik Jon® Ultima Model 203 Sewage Removal System	203-0005	203-1006
2	203 replacement pump with discharge pipe	017374	152165
3	Tank cover with discharge fittings	017373	017373
4	Tank	018513	018513
5	Seal	017350	017350
6	Float switch assembly	018501	018501
7	Flange extension kit	018510	018510
8	Closet seal	017347	017347

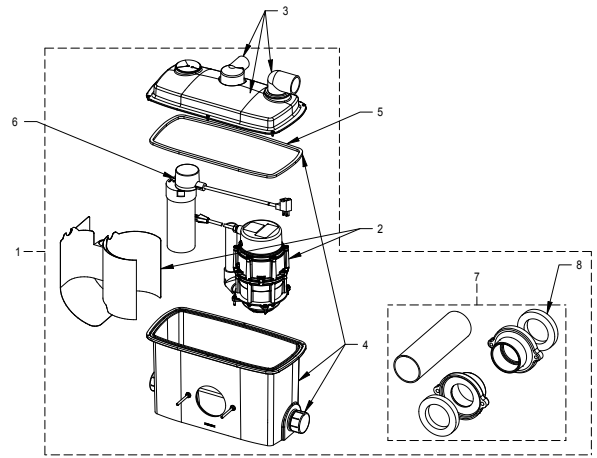

SK2613

## TROUBLE SHOOTING

CONDITION	POSSIBLE CAUSE	REMEDY
<b>A. PUMP WILL NOT START OR RUN.</b>	Low voltage, blown fuse, open circuit.	Have a qualified electrician check fuse and circuit.
	Impeller bound.	Contact a Zoeller Service Station.
	Motor or wiring shorted.	
	Debris on float switch.	Remove debris.
<b>B. PUMP STARTS TOO SOON.</b>	Float "ON" point is adjusted too low.	Raise the float stops, make sure the float is between the two stops.
<b>C. WATER LEVEL EXCESSIVE BEFORE PUMP TURNS ON.</b>	Float "ON" point adjusted too high.	Lower the upper float stop.
<b>D. PUMP WILL NOT SHUT OFF OR RUNS TOO LONG BEFORE WATER IS PUMPED.</b>	Pump not plugged into piggyback float switch receptacle.	Ensure pump is not plugged directly into the outlet. Plug pump into piggyback float switch receptacle.
	Debris under float.	Remove debris from around float.
	Faulty float switch.	Contact a Zoeller Service Station.
	Float "Off" point adjusted too low.	Raise the lower float stop.
	Pump is air locked.	Make sure vent hole in discharge pipe is clear.
	Water level too low.	Raise the lower float stop.
	Waste material has accumulated, blocking flow of material to pump intake.	Hold flush handle down on the toilet for 15 seconds. If unit will not clear, unplug and wait 30 minutes. Plug unit back in and repeat. If unit still will not turn off, it will need to be opened and the debris relocated.
<b>E. PUMP OPERATES BUT DELIVERS LITTLE OR NO WATER.</b>	Debris around intake.	Clean area around intake.
	Blockage in discharge pipe.	Remove pipe and flush out debris.
	Low or incorrect voltage.	Have a qualified electrician check house wiring.
	Damaged Impeller.	Contact a Zoeller Service Station.
	Incorrect float adjustment.	Contact Product Support Dept.
	Pump is air locked.	Make sure vent hole in discharge pipe is clear.
	Vertical lift too high.	Change discharge piping or contact Product Support Dept.

If the above checklist does not solve the problem, consult the Zoeller Product Support Department (502) 778-2731. **Do not** attempt to service or otherwise disassemble pump. Care of finish: Soap and water is all that is recommended for cleaning the outside of the tank. Other cleaning products may cause discoloration and scratching.

# QWIK JON® ULTIMA QWIK REFERENCE GUIDE

## STEP 1

## LOCATION SELECTION

Plan your new installation carefully.

**Floor:** The floor should be structurally sound and level within  $\frac{1}{8}$ ". If the floor is not level, use hydraulic cement or similar material to level the floor.

**Water:** A water supply will be needed to operate the shower and lav.

**Electrical:** A 115 volt GFCI receptacle will be needed to supply electrical power to the pump.

**Sewage:** Access to a sewage line is required. The Qwik Jon® Ultima requires a 1" (or 3/4" if codes permit) sewage discharge line to connect to an existing sewage line. A ball or gate valve should be installed in the discharge line.

**Vent:** Access to a vent pipe is required. The use of a mechanical vent system is NOT recommended., as the toilet will not flush.

**NOTE:** If a built-in installation is to be used, locate the pump unit in an area that will allow access to the pump and switch.

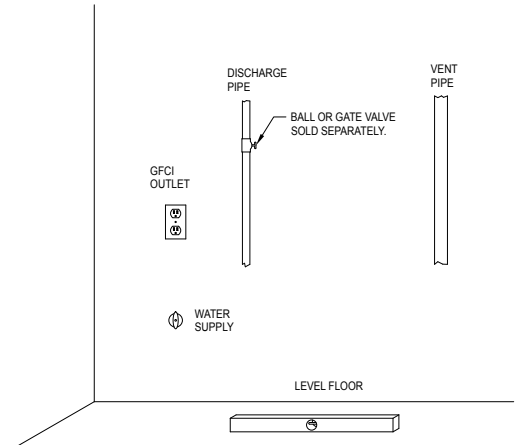

SK2588

## STEP 2

## LEVELING OF PUMP UNIT

**CAUTION** Do not use wooden shims to level the pump unit!

**CAUTION** Ensure that nails, screws or other sharp objects do not puncture the pump unit!

Level the pump unit within  $\frac{1}{8}$ " using hydraulic cement or similar material.

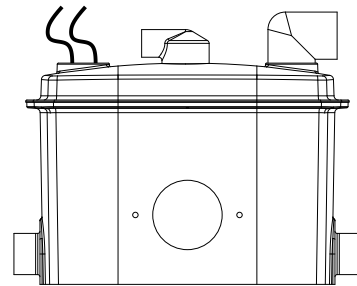

SK2614

## STEP 3

## ROUGH-IN

### (STAND-ALONE INSTALLATION)

- 1) Position the pump unit a minimum of  $\frac{1}{8}$ " from the wall with the inlet facing forward. Attach the bellows to the inlet using the worm drive clamp provided.
- 2) Place the toilet in front of pump unit aligning the discharge of the toilet with the inlet of the pump unit. Make sure that the bellows will bridge the gap adequately for final installation. The toilet tank should be a minimum of  $\frac{1}{2}$ " from the wall.
- 3) Lightly mark the locations of the pump unit, toilet and closet bolt locations on the floor. Lightly mark the wall with the height of the pump unit and the bottom and sides of the toilet tank to ensure against interference from pipe runs later.
- 4) Remove the toilet from the pump unit and set it aside.

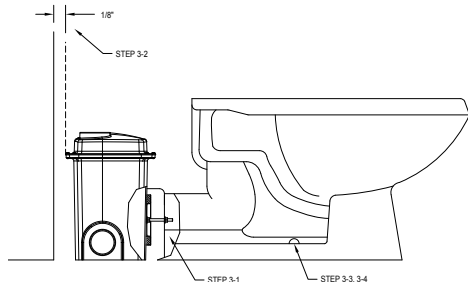

SK2615

### (BEHIND THE WALL INSTALLATION)

- 1) Installing the grinder unit behind a wall will require an extension kit (P/N 10-2123) sold separately.
- 2) Place the toilet assembly a minimum of  $\frac{1}{2}$ " from the wall and mark the closet bolt locations on the floor.
- 3) Measure the appropriate length of  $\frac{3}{2}$ " Schedule 40 PVC pipe provided with the extension kit and cut it to length. See sketch at right.
- 4) Set toilet aside.

**CAUTION** Toilet assembly is top heavy. Take special precautions to ensure that toilet does not tip over and break.

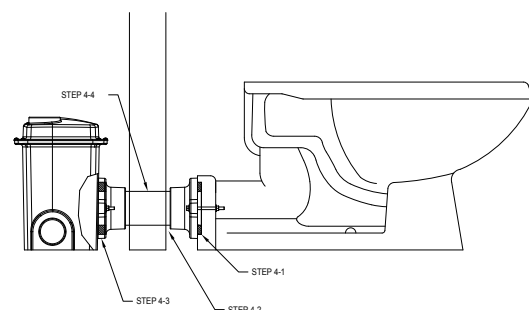

SK2616

## STEP 4

## PIPING

1) Adding bathroom fixtures - The Qwik Jon® Ultima is designed to accept bathroom fixtures utilizing the two side inlets. These inlets can be attached via the 2" MPT (outside diameter) or the 1½" slip (inside diameter). These inlets must have the inner portion drilled out using a 44 mm (1¾") hole saw (see Figure 3.2). This is to ensure there are no leakage problems from inlets not in use. When utilizing side inlets, install a check valve on the incoming line.

2) Cut and dry-fit the pipe and fittings as required for 1" diameter discharge pipe (may be reduced to ¾" diameter if codes permit).

3) While dry-fitting the discharge pipe, position and mark the location of the pump unit discharge fitting.

4) Cut and dry-fit 1½" vent pipe as required to ensure that the vent pipe does not interfere with other components. Make the connection to the pump unit with the provided street elbow. A 2" x 1" 90° discharge fitting has been provided, however, it may be easier to pipe straight up depending on the installation. **CAUTION** Proper venting is required. Do not use a mechanical type vent.

5) Clean, prime and solvent weld the inlet and discharge piping and pump unit discharge fitting. **CAUTION** When applying solvent weld to discharge fitting, ensure that none gets into the check valve assembly (see Figure 3.3). Pay close attention to the proper alignment of the discharge fitting previously marked above.

6) Clean and solvent weld vent piping as required for proper venting.

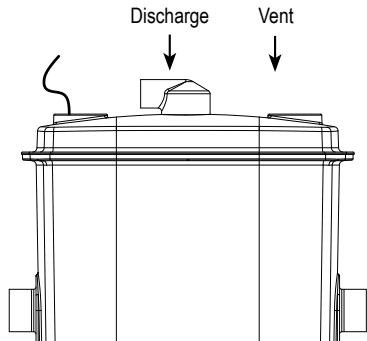

Figure 3.1

SK2673

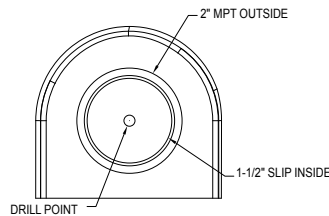

Figure 3.2

SK2586

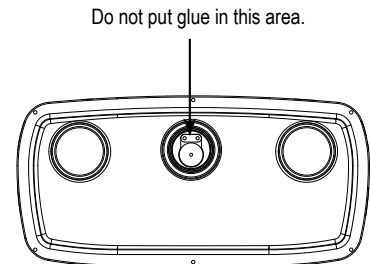
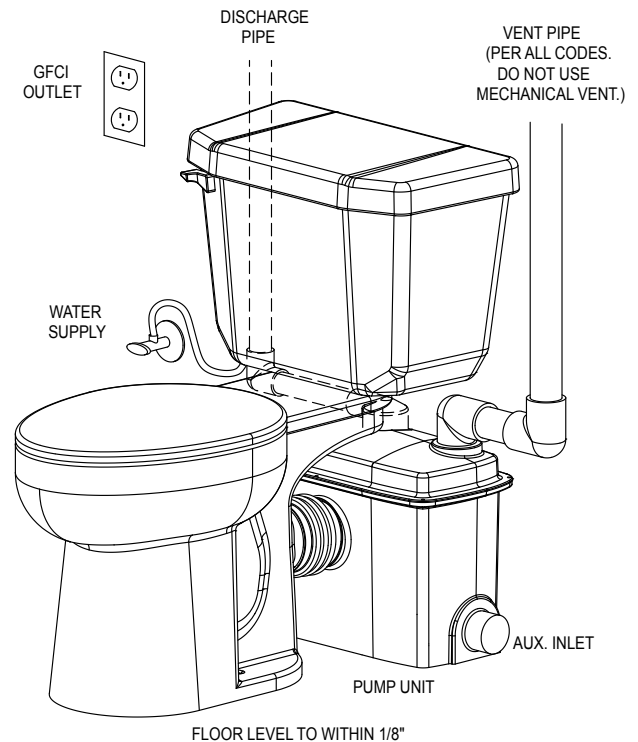

Figure 3.3

SK2591

## STEP 5 TOILET INSTALLATION (TOILET SUPPLIED BY OTHERS)

- 1) Install the closet bolts at the points marked earlier.
- 2) Place the toilet assembly over the closet bolts. Install the anchoring hardware and tighten in an alternating pattern. Check for level and shim as required. Be careful when tightening bolts or nuts against china to avoid cracking the china.
- 3) Install rubber bellows onto the toilet discharge and grinder tank hub and secure with the worm clamps provided for installation. See sketch in Step 3. For built-in installation, install the rubber couplings to both the grinder tank and the toilet discharge and secure to extension pipe with worm clamps provided. See sketch in Step 4.
- 4) Install the water supply line from the existing water shut-off valve to the toilet water supply connection.
- 5) Open the water supply valve and check for leaks. The toilet tank should fill to the proper level. Adjust if required.
- 6) Plug the pump's power cord into the outlet.
- 7) Flush the toilet and watch for proper operation. Listen for the pump to start. The pump unit requires proper venting in order for toilet to flush. Check for leaks.
- 8) Repeat flush cycles to assure proper operation.



NOTE: May not be pictured exactly as shown.

SK2595

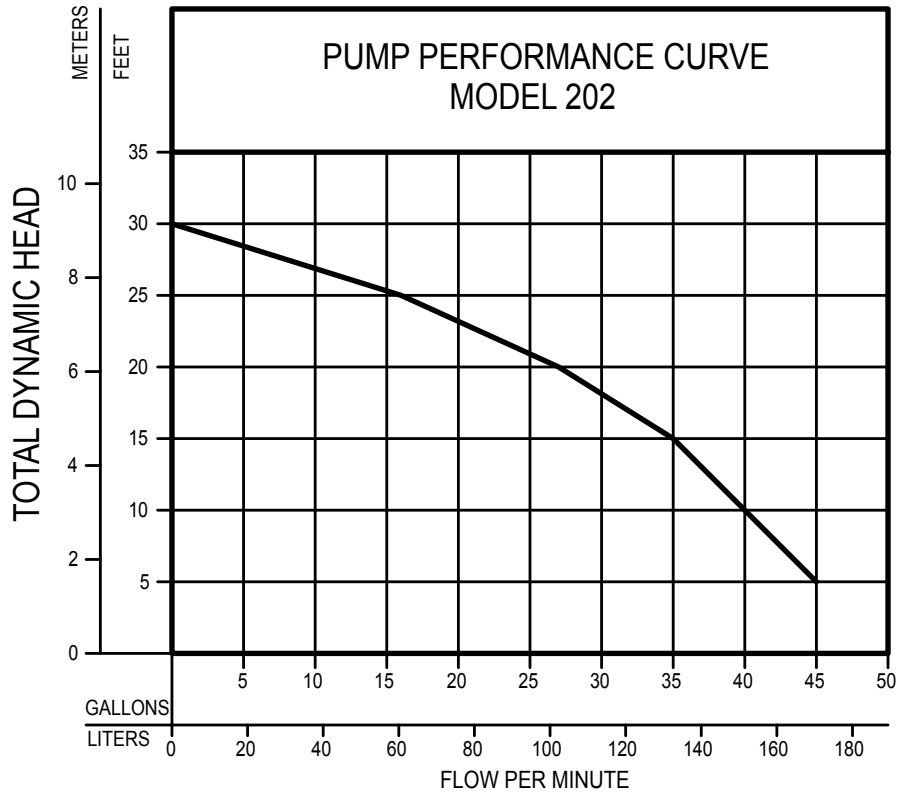

**TOTAL DYNAMIC HEAD/FLOW  
PER MINUTE  
SEWAGE**

MODEL		202	
Feet	Meters	Gal.	Liters
5	1.5	45	170
10	3.0	40	151
15	4.6	35	132
20	6.1	27	102
25	7.6	16	61
Shut-off Head:		30 ft. (9.1m)	

018512



**PUMP COMPANY**

**MAIL TO:** P.O. BOX 16347 • Louisville, KY 40256-0347  
**SHIP TO:** 3649 Cane Run Road • Louisville, KY 40211-1961  
(502) 778-2731 • 1 (800) 928-PUMP • FAX (502) 774-3624

**Your Peace of Mind is Our Top Priority®**

**visit our web site:**  
**[www.zoeller.com](http://www.zoeller.com)**

