

# LC, LCV, LF, LCS

End suction centrifugal pumps

Installation and operating instructions

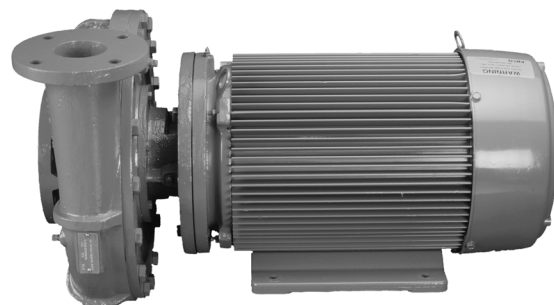
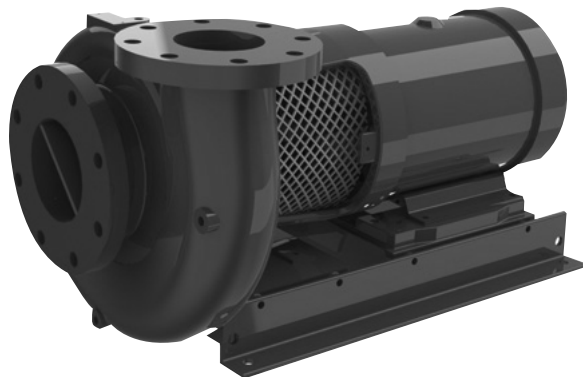
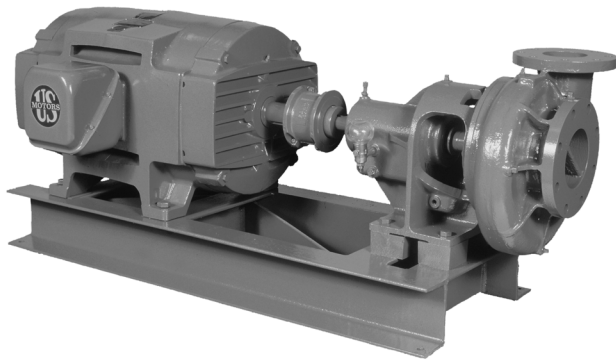

## Original installation and operating instructions.

## CONTENTS

	Page
<b>1. Symbols used in this document</b>	<b>2</b>
<b>2. Terms and Conditions</b>	<b>2</b>
2.1 The contract	2
2.2 Price	3
2.3 Payment terms	3
2.4 Acceptance and inspection	3
2.5 Title and risk of loss	3
2.6 Patent or trademark information	3
2.7 Changes	3
2.8 Cancellation or termination	3
2.9 Delivery and delays	3
2.10 Warranty	4
2.11 Technical documents	4
2.12 Limitation of liability	4
2.13 This company is an equal opportunity employer	4
2.14 law and arbitration	5
<b>3. Installation - Mechanical</b>	<b>5</b>
3.1 Pump identification	5
3.2 Receiving	5
3.3 Temporary storage	5
3.4 Location	5
3.5 Horizontal pump foundation	5
3.6 Securing base plate	6
3.7 Vertical mounting instructions	6
3.8 Piping-general	6
3.9 Suction (inlet) piping	6
3.10 Discharge (outlet) piping	7
3.11 Shaft sealing-general comments	7
3.12 Packing gland adjustment	7
3.13 Mechanical seals	7
3.14 Coupling alignment (LF)	8
3.15 Coupling alignment (LCS)	8
<b>4. Installation-electrical</b>	<b>8</b>
4.1 Motors general	8
4.2 Installation wiring	8
<b>5. Operation</b>	<b>9</b>
5.1 Priming	9
5.2 Pre-start checklist	9
5.3 Motor rotation	9
5.4 Starting the pump	9
5.5 Voltage regulation	10
5.6 Pump shutdown	10
5.7 Short duration shutdown	10
5.8 Extended period shutdown	10
<b>6. Maintenance</b>	<b>10</b>
6.1 Motor lubrication	10
6.2 Pump lubrication	11
6.3 Disassembly of pumps	12
6.3.1 Disassembly of liquid end	12
6.3.2 Disassembly of bearing frame (LF)	12
6.4 Seal replacement (LCS)	12
6.5 Wear ring replacement	12
6.6 Reassembly of pumps	13
6.7 Ordering parts	13
6.8 Type LF, cross section and parts list	14
6.9 Type LC, cross section and parts list	15
6.10 Type LCV, cross section and parts list	16
6.11 Type LCS, cross section and parts	17

<b>7. Trouble Shooting</b>	<b>18</b>
7.1 Symptom	18
7.2 Possible Causes	18

**1. Symbols used in this document**

The following symbols may be used in this document.

**Warning**

*If these safety instructions are not observed, it may result in personal injury.*

**Warning**

*If these instructions are not observed, it may lead to electric shock with consequent risk of serious personal injury or death.*

**Warning**

*When pumping hazardous liquids, special attention must be paid to the risk of personal injury.*

**Warning**

*The surface of the product may be so hot that it may cause burns or personal injury.*

**Warning**

*The sound pressure level is so high that hearing protection must be used.*

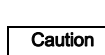
**Caution**

*If these safety instructions are not observed, it may result in malfunction or damage to the equipment.*

**Note**

*Notes or instructions that make the job easier and ensure safe operation.*

**2. Terms and Conditions****2.1 The contract**

The Contract shall be comprised of the following terms, together with such terms and conditions as are set forth in Seller's written proposal or quotation (the "Quotation"), including any documents, drawings or specifications incorporated therein by reference, and any additional or different terms proposed in Buyer's purchase order (the "Purchase Order") that are accepted by Seller in writing, which together shall constitute the entire agreement between the parties, provided, however, that preprinted terms on Buyer's purchase order or invoice shall not apply and Seller gives notice of objection to such terms. An offer by Seller in its Quotation that does not stipulate an acceptance date is not binding. This Contract shall be deemed to have been entered into upon written acknowledgment of the Purchase Order by an officer or authorized representative of Seller, which may not be modified, supplemented, or waived except in a writing executed by an authorized representative of the party to be bound.

## 2.2 Price

The price quoted in the Quotation shall be the Purchase Price unless otherwise agreed in the Purchase Order. The Purchase Price for equipment shall include packing for shipment. Field Services shall be provided at Seller's standard rates. All other costs, including packing for storage, freight, insurance, taxes, customs duties and import/export fees, or any other item not specified in the Contract, shall be paid by Buyer unless separately stated in the Quotation and included in the price quoted. Any sales, use, or other taxes and duties imposed on the transaction or the equipment supplied shall be paid or reimbursed by Buyer.

## 2.3 Payment terms

Payment shall be due within 30 days of the date of Seller's invoice in U.S. funds unless otherwise agreed. If Buyer does not observe the agreed dates of payment, Buyer shall pay interest to Seller on overdue amounts at a rate that is the higher of: 9 % per annum or a rate 5 % in excess of the rate borne from time to time by new issues of six-month United States Treasury bills. Seller shall be entitled to issue its invoice for the Purchase Price for equipment upon the earlier of shipment, or notice to Buyer that Seller is ready to ship, and for services, upon completion. If the Purchase Price exceeds \$250,000 USD, Buyer shall pay the Purchase Price in Progress payments as follows: Fifteen percent (15 %) upon submittal of general arrangement drawings, thirty five percent (35 %) after receipt of first Bowl Casting, twenty percent (20 %) after first case/bowl hydro test or bowl machining and thirty percent (30 %) after notification of ready to ship.

## 2.4 Acceptance and inspection

All equipment shall be finally inspected and accepted by Buyer within 14 days after delivery or such other period of time as is agreed in the Purchase Order. Buyer shall make all claims (including claims for shortages), excepting only those provided for under the warranty clause contained herein, in writing within such 14 day period or they are waived. Services shall be accepted upon completion. Buyer shall not revoke its acceptance. Buyer may reject the equipment only for defects that substantially impair its value, and Buyer's remedy for lesser defects shall be in accordance with Section 10, Warranty. If tests are made by Buyer to demonstrate the ability of the equipment to operate under the contract conditions and to fulfill the warranties in Section 10, Buyer is to make all preparations and incur all expenses incidental to such tests. Seller will have the right of representation at such tests at its expense, and the right to technically direct the operation of the equipment during such tests, including requiring a preliminary run for adjustments.

## 2.5 Title and risk of loss

Full risk of loss (including transportation delays and losses) shall pass to Buyer upon delivery, regardless of whether title has passed to Buyer, transport is arranged or supervised by Seller, or start-up is carried out under the direction or supervision of Seller. Delivery shall be ex works, INCOTERMS 2000. Loss or destruction of the equipment or injury or damage to the equipment that occurs while the risk of such loss or damage is borne by Buyer does not relieve Buyer of its obligation to pay Seller for the equipment.

## 2.6 Patent or trademark information

If the equipment sold hereunder is to be prepared or manufactured according to Buyer's specifications, Buyer shall indemnify Seller and hold it harmless from any claims or liability for patent or trademark infringement on account of the sale of such goods.

## 2.7 Changes

Buyer may request, in writing, changes in the design, drawings, specifications, shipping instructions, and shipment schedules of the equipment. As promptly as practicable after receipt of such request, Seller will advise Buyer what amendments to the Contract, if any, may be necessitated by such requested changes, including but not limited to amendment of the Purchase Price, specifications, shipment schedule, or date of delivery. Any changes agreed upon by the parties shall be evidenced by a Change Order signed by both parties.

## 2.8 Cancellation or termination

Buyer shall have the right to cancel the Contract upon 15 days' prior written notice to Seller, and Seller shall stop its performance upon the receipt of such notice except as otherwise agreed with Buyer. If Buyer cancels the Contract, it shall pay: (a) the agreed unit price for equipment or components completed and delivered, (b) additional material and labor costs incurred, and for engineering services supplied by Seller with respect to the canceled items, which shall be charged to Buyer at Seller's rates in effect at the time of cancellation, but which shall not exceed the contract price for such items, and (c) such other costs and expenses, including cancellation charges under subcontracts, as Seller may incur in connection with such cancellation or termination.

## 2.9 Delivery and delays

Seller shall use its best efforts to meet quoted delivery dates, which are estimated based on conditions known at the time 16 A1d.1 606 supercedes 9/05 PACO PUMPS of quotation. Seller shall not be liable for any nonperformance, loss, damage, or delay due to war, riots, fire, flood, strikes or other labor difficulty, governmental actions, acts of God, acts of the Buyer or its customer, delays in transportation, inability to obtain necessary labor or materials from usual sources, or other causes beyond the reasonable control of Seller. In the event of delay in performance due to any such cause, the date of delivery or time for completion will be extended to reflect the length of time lost by reason of such delay. Seller shall not be liable for any loss or damage to Buyer resulting from any delay in delivery.

## 2.10 Warranty

Seller warrants that the equipment or services supplied will be free from defects in material, and workmanship for a period of 12 months from the date of initial operation of the equipment, or 18 months from the date of shipment, whichever shall first occur. In the case of spare or replacement parts manufactured by Seller, the warranty period shall be for a period of six months from shipment. Repairs shall be warranted for 12 months or, if the repair is performed under this warranty, for the remainder of the original warranty period, whichever is less. Buyer shall report any claimed defect in writing to Seller immediately upon discovery and in any event, within the warranty period. Seller shall, at its sole option, repair the equipment or furnish replacement equipment or parts thereof, at the original delivery point. Seller shall not be liable for costs of removal, reinstallation, or gaining access. If Buyer or others repair, replace, or adjust equipment or parts without Seller's prior written approval, Seller is relieved of any further obligation to Buyer under this section with respect to such equipment or parts. The repair or replacement of the equipment or spare or replacement parts by Seller under this section shall constitute Seller's sole obligation and Buyer's sole and exclusive remedy for all claims of defects. SELLER MAKES NO OTHER WARRANTY OR REPRESENTATION OF ANY KIND WITH RESPECT TO THE EQUIPMENT OR SERVICES OTHER THAN AS SPECIFIED IN THIS SECTION 10. ALL OTHER WARRANTIES, EXPRESS OR IMPLIED, INCLUDING BUT NOT LIMITED TO, THE IMPLIED WARRANTIES OF MERCHANTABILITY AND FITNESS FOR A PARTICULAR PURPOSE, ARE HEREBY DISCLAIMED. For purposes of this Section, the equipment warranted shall not include equipment, parts, and work not manufactured or performed by Seller. With respect to such equipment, parts, or work, Seller's only obligation shall be to assign to Buyer any warranty provided to Seller by the manufacturer or supplier providing such equipment, parts or work. No equipment furnished by Seller shall be deemed to be defective by reason of normal wear and tear, failure to resist erosive or corrosive action of any fluid or gas, Buyer's failure to properly store, install, operate or maintain the equipment in accordance with good industry practices or specific recommendations of Seller, or Buyer's failure to provide complete and accurate information to Seller concerning the operational application of the equipment.

## 2.11 Technical documents

Technical documents furnished by Seller to Buyer, such as drawings, descriptions, designs and the like, shall be deemed provided to Buyer on a confidential basis, shall remain Seller's exclusive property, shall not be provided in any way to third parties, and shall only be used by Buyer for purposes of installation, operation and maintenance. Technical documents submitted in connection with a Quotation that does not result in a Purchase Order shall be returned to Seller upon request.

## 2.12 Limitation of liability

Seller shall in no event be liable for any consequential, incidental, indirect, special or punitive damages arising out of the Contract, or out of any breach of any of its obligations hereunder, or out of any defect in, or failure of, or malfunction of the equipment, including but not limited to, claims based upon loss of use, lost profits or revenue, interest, lost goodwill, work stoppage, impairment of other equipment, environmental damage, nuclear incident, loss by reason of shutdown or nonoperation, increased expenses of operation, cost of purchase of replacement power or claims of Buyer or customers of Buyer for service interruption whether or not such loss or damage is based on contract, tort (including negligence and strict liability) or otherwise. Seller's maximum liability under this Contract shall not exceed the Purchase Order amount of the equipment or portion thereof upon which such liability is based. All such liability shall terminate upon the expiration of the warranty period, if not sooner terminated.

## 2.13 This company is an equal opportunity employer

This agreement incorporates by reference applicable provisions and requirements of Executive Order 11246 and FAR Section 52.222-26 (covering race, color, religion, sex and national origin); the Vietnam Era Veterans Readjustment Assistance Act of 1974 and FAR Section 52.222-35 (covering special disabled and Vietnam era veterans); and the Rehabilitation Act of 1973 and FAR Section 52.222-36 (covering handicapped individuals). By acceptance of this agreement Buyer certifies that it does not and will not maintain any facilities in a segregated manner, or permit its employees to perform their services at any location under its control where segregated facilities are maintained, and further that appropriate physical facilities are maintained for both sexes. Buyer agrees that it will obtain a similar certificate prior to award of any nonexempt lower-tier subcontracts.

## 2.14 law and arbitration

The Contract shall be governed by the law of the State of Texas. Any disputes arising out of this Contract shall be resolved by informal mediation in any manner that the parties may agree within 45 days of written request for mediation by one party to the other. Any dispute that cannot be resolved through mediation shall be resolved by binding arbitration conducted in English in Portland, Oregon under the Commercial Rules of the American Arbitration Association except as otherwise provided in this Section. The arbitration shall be conducted by three arbitrators chosen in accordance with said Rules. The arbitrators are not entitled to award damages in excess of compensatory damages. Judgment upon the award may be entered in any court having jurisdiction.



### Warning

**Prior to installation, read these installation and operating instructions. Installation and operation must comply with local regulations and accepted codes of good practice.**



### Warning

**The use of this product requires experience with and knowledge of the product. Persons with reduced physical, sensory or mental capabilities must not use this product, unless they are under supervision or have been instructed in the use of the product by a person responsible for their safety. Children must not use or play with this product.**

## 3. Installation - Mechanical

Read these instructions thoroughly before installing and operating your PACO Type L Centrifugal Pump. Successful operation depends on careful attention to the procedures described in Sections 1, 2, 3 and 4 of this manual. Keep this instruction manual handy for future use.

### 3.1 Pump identification

All PACO Pumps are identified by Catalog and Serial Numbers. These numbers are stamped on the pump nameplate (Fig. 1) affixed to each pump volute casing, and should be referred to in all correspondence with the Company.

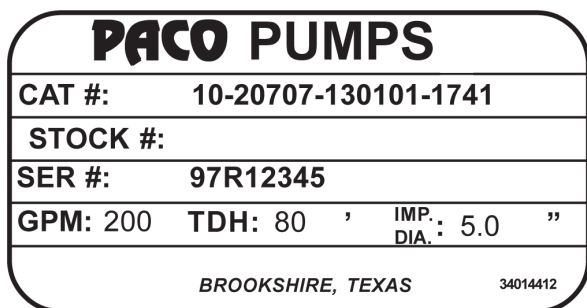

TM 05 8912 3712

Fig. 1 Nameplate

## 3.2 Receiving

- Check pumping unit for shortage and damage immediately upon arrival. Pump accessories when required are packaged in a separate container and shipped with the unit.
- If equipment is damaged in transit, promptly report this to the carrier's agent. Make complete notations on the freight bill to speed satisfactory adjustment by the carrier.
- Unload and handle the unit with a sling. Do not lift unit by eye bolts on the motor!

## 3.3 Temporary storage

- If pump is not to be installed and operated soon after arrival, store it in a clean, dry area of moderate ambient temperature.
- Rotate the shaft by hand periodically to coat bearing with lubricant to retard oxidation and corrosion.
- Follow motor manufacturer's storage recommendations where applicable.

## 3.4 Location

- Locate the pump as close to the suction supply as possible. Use the shortest and most direct suction piping practical. Refer to 3.9 *Suction (inlet) piping*.
- Locate the pump below system level wherever possible. This will facilitate priming, assure a steady liquid flow, and provide a positive suction head.
- Make sure sufficient NPSH (Net Positive Suction Head) is provided at the suction end by considering the pump's location in relation to the entire system. Available NPSH must always equal or exceed required NPSH specified on the pump performance curve.
- Always allow sufficient accessibility for maintenance and inspection. Provide a clear space with ample head room for use of a hoist strong enough to lift the unit.
- Make sure a suitable power source is available for the pump motor. Electrical characteristics should match those specified on the motor data plate, within the limits covered in 4. *Installation-electrical* and 5. *Operation*.
- Avoid pump exposure to sub-zero temperatures to prevent pump liquid from freezing. If freezing conditions exist during shutdown periods, see Sections 5.6 *Pump shutdown* and 5.7 *Short duration shutdown* for specific recommendations.

## 3.5 Horizontal pump foundation

Horizontal pumps should be permanently installed on a firm, concrete foundation mounting pad of sufficient size to dampen any vibration and prevent any deflection or misalignment. The pad may float on springs or be a raised part of the equipment room floor. The foundation should be poured without interruption to 3/4 to 1 - 1/2 inches below the final pump elevation. The top surface should be well scored or grooved before the concrete sets to provide a suitable bonding surface for the grout. Anchor bolts should be set in pipe sleeves for positioning allowance, as shown in Fig. 2. Allow enough bolt length for grout, lower base plate flange, nuts and washers. Allow the foundation to cure several days before proceeding with pump installation.

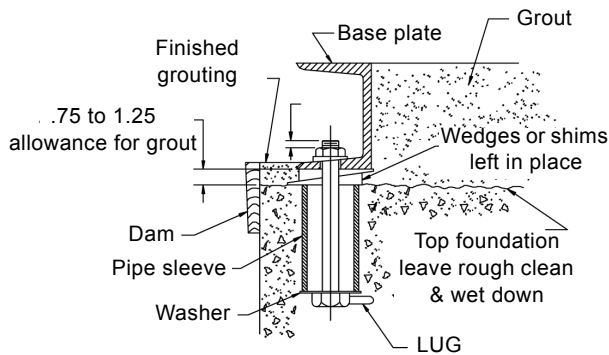

Fig. 2 Anchor bolt installation

### 3.6 Securing base plate

- After the concrete pad has been poured and set, lower the pump base plate over the anchor bolts and rest it on loose adjustment wedges or shims placed near each anchor bolt and at intervals not to exceed 24" along each side. Shims or wedges must be placed to raise the bottom of the base  $\frac{3}{4}$ " to 1 -  $\frac{1}{4}$ " above the pad, allowing clearance for grout. Level the pump shaft, flanges, and base plate using a spirit level, adjusting the wedges or shims, as required.
- Check to make sure that the piping can be aligned to the pump flanges without placing any strain on either flange.
- After pump alignment has been established (LF), put nuts on foundation bolts and tighten them just enough to keep the unit base plate from moving. Construct a form or dam around the concrete pad and pour grout in and around the pump base, as shown in Fig. 2. Grout compensates for uneven foundation, distributes the weight of the unit, and prevents shifting. Use an approved, non shrinking grout (such as Embeco 636 by Master Builders, Cleveland, Ohio or equivalent). Allow at least 24 hours for this grout to set before proceeding with piping connections.
- After the grout has thoroughly hardened, check the foundation bolts and tighten if necessary. Recheck the pump alignment after the foundation bolts are secured.
- No alignment or grouting required for LCS pump.

### 3.7 Vertical mounting instructions

The PACO LCV Vertical Close Coupled pump need not be grouted to its foundation, but should be anchored with 4 anchor bolts set in concrete similar to the horizontal anchoring arrangement Fig. 2.

### 3.8 Piping-general

- Do not use pump as a support for piping! Use pipe hangers or other supports at proper intervals to provide complete piping support near the pump.
- Both suction and discharge piping should be independently supported and properly aligned so that no strain is transmitted to the pump when flange bolts are tightened.
- Make sure piping is as straight as possible, avoiding unnecessary bends and fittings. Where necessary, use 45 ° or long-sweep 90 ° pipe fittings to decrease friction loss.
- Where flanged joints are used, make sure that inside diameters properly match and mounting holes are aligned.
- Do not spring or force piping when making any connections!

### 3.9 Suction (inlet) piping

The sizing and installation of suction piping is particularly important. It must be selected and installed in a manner that minimizes pressure loss and permits sufficient liquid flow into the pump during starting and operation. Many NPSH problems can be traced directly to improper design of suction piping systems. Observe the following precautions when installing suction piping:

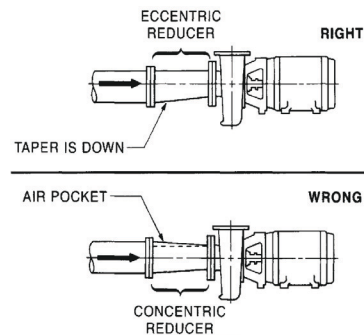

Fig. 3 Inlet piping

- Suction piping should be as direct as possible, and ideally the length should be at least ten times the pipe diameter. Short suction piping can be the same diameter as the suction opening. Longer piping should be one or two sizes larger (depending on length), reducing to the diameter of the pump suction opening.
- Use an eccentric reducer, with the eccentric side down Fig. 3 when reducing the pipe diameter to the diameter of suction opening.
- At no point should suction piping be smaller in diameter than the pump suction opening.
- Horizontal suction lines should follow an even gradient, if possible. A gradual upward slope to the pump is recommended for suction lift conditions, and a gradual downward slope for positive suction head.
- Avoid any high points, such as pipe loops Fig. 4, that may create air pockets and throttle the system or produce erratic pumping.
- Install a valve in the suction line to isolate the pump during shutdown and maintenance, and facilitate pump removal. Where two or more pumps are connected to the same suction line, install duplicate gate valves to isolate each pump from the line.
- Gate valves should always be installed in positions that avoid air pockets. Globe valves should not be used, particularly when NPSH is critical.
- During pumping operation, valves on suction line must always be at FULL OPEN.
- Properly sized pressure gauges can be installed in gauge taps on pump suction and discharge nozzles. Gauges enable the operator to monitor pump performance and determine that the pump conforms to the parameters of the performance curve. If cavitation, vapor binding, or other unstable operation occurs, pressure gauges will indicate wide fluctuation in suction and discharge pressures.

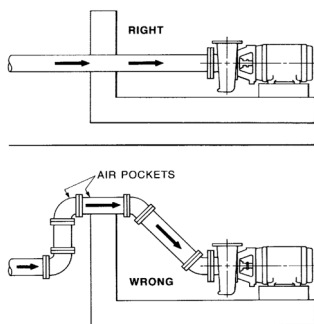

Fig. 4 Air pocket prevention

### 3.10 Discharge (outlet) piping

- Short discharge piping can be the same diameter as the pump discharge opening. Longer piping should be one or two sizes larger depending on length.
- An even gradient is best for long horizontal runs of discharge piping.
- Install a valve near the discharge opening to prime and start the pump. The discharge gate valve is also used to isolate the pump during shutdown, maintenance, and facilitate pump removal.
- Any high points in discharge piping may entrap air or gas and thus retard pump operation.
- If the possibility of liquid hammer exists, (i.e. check valves are used) close the discharge gate valve before pump shutdown.

### 3.11 Shaft sealing-general comments

- PACO offers both mechanical seals and packed stuffing boxes as a means to seal the shaft. Pumps with stuffing boxes are normally packed before shipment. If the pump is installed within 60 days after shipment, the packing material will be in good condition for operation with a sufficient supply of lubrication. If the pump is stored for a longer period, it may be necessary to repack the stuffing boxes.
- The stuffing box must be supplied at all times with a source of clean, clear liquid to flush and lubricate the packing. When pumps are equipped with mechanical seals, no maintenance or adjustment is required. Mechanical seals are preferred to packing on most applications because they require less maintenance.

### 3.12 Packing gland adjustment

With the pump running, the packing gland should be adjusted to permit 40 to 60 drops per minute leakage. This is required for shaft lubrication. After initial start up, additional packing and adjustment may be required. Pumps with mechanical seals require no adjustment.

### 3.13 Mechanical seals

All PACO Type L pumps that are equipped with mechanical seals are matched to conditions for which the pump was sold. Observe the following precautions to avoid seal damage and obtain maximum seal life:

- Do not exceed temperature or pressure limitations for the mechanical seal used.
- DO NOT RUN THE PUMP DRY OR AGAINST A CLOSED VALVE! Dry operation will cause seal failure within minutes.
- Clean and purge suction piping in new installations before installing and operating pump. Pipe scale, welding slag and other abrasives can cause rapid seal failure.

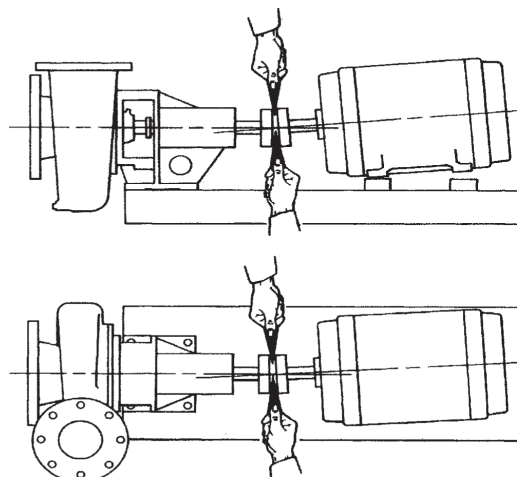

Fig. 5 Checking parallel alignment

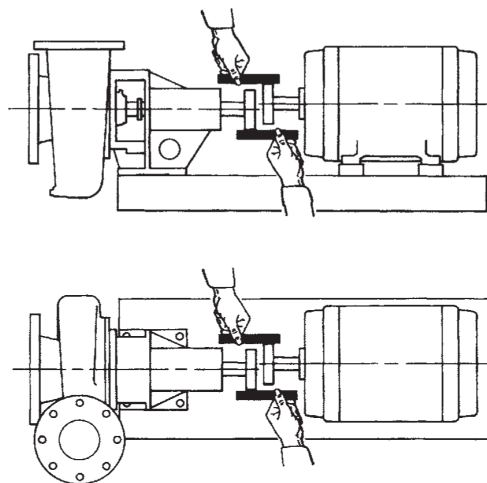

Fig. 6 Checking alignment

TM05 4792 2613

TM05 4795 2613

TM05 4794 2613

### 3.14 Coupling alignment (LF)

- The following anchoring and alignment procedure is typical and, if performed with care, should result in a smooth running, trouble-free installation.
- If the pump and motor were shipped mounted on the pump base as an assembly, remove the coupling guard.
- The pump and motor were accurately aligned at the factory, but handling during shipment usually alters this pre-alignment. Using a small straight edge and feeler gauges or a dial indicator, check for horizontal, vertical, and angular misalignment of the coupling hubs Fig. 5 and Fig. 6.
- Coupling alignment is correct when the dial indicator reads no more than .005" run out in any direction (or when the straight edge contacts both hubs evenly in both horizontal and vertical positions). If misalignment is detected, loosen the motor and shift or shim as necessary to re-align, then re-tighten bolts. Always align the motor to the pump as piping strain will occur if the pump is shifted. Never reposition pump on base!
- After final piping connections to the pump have been made, motor wiring compared, correct rotation has been established, and piping filled with liquid, check shaft alignment once again.
- Leave the coupling guards off until the pump priming procedure is completed for a final shaft alignment check.
- To protect personnel from rotating machinery, Always install coupling guards after installation is complete; before starting pump!

### 3.15 Coupling alignment (LCS)

- No alignment of the pump and motor is required.

## 4. Installation-electrical



#### **Warning**

**Use only qualified electricians for electrical installation and maintenance.**

**Refer to manuals provided with electrical accessory components and disconnect power supply as recommended for servicing.**



#### **Warning**

**Never do maintenance work when the unit is connected to power.**

### 4.1 Motors general

the motor control circuit must have the following components in order to comply with the National Electrical Code.

- Motor Disconnecting Device: A motor disconnecting device must be installed that is capable of disconnecting both the controller (motor starter) and the motor from their source of power.
- The disconnecting device must be located so that the controller (motor starter) can be seen from the disconnecting means. In all cases, the distance from the disconnecting device to the controller must be less than 50'.
- In most installations the disconnecting device will be a circuit breaker or fusible disconnect switch.

Motor short circuit and ground fault protection:

- Short circuit and ground fault protection are usually provided by means of a circuit breaker or fusible disconnect switch.
- The selection of the size of the circuit breaker or fuse must be in accordance with Section 430-52 and Table 430-152 of the National Electrical Code.

Motor controller with running over current protection (magnetic starter):

- These components must be installed in accordance with applicable local and state electrical codes in addition to the National Electrical Code.



#### **Warning**

**Whenever powered equipment is being used in explosive surroundings, the rules and regulations generally or specifically imposed by the relevant responsible authorities or trade organizations must be observed.**

### 4.2 Installation wiring

- Mount the control panel or motor starter(s) in close proximity to the pump to provide convenient control and ease of installation.
- Wire panel or starter(s) to motor(s) and pilot device(s): Wires to each motor must be sized for at least 125 % of the motor nameplate full load amps. AWG #16 Type THW stranded wire is recommended for wiring of pilot devices (float switches).
- Check incoming power source to ensure that it is the same as the voltage and phase of the motors.
- Verify that the starters are suitable to operate the pump motors on voltage and phase that is available.



## 5. Operation

### 5.1 Priming

- The PACO Type L pump is not self-priming, and must be completely primed (filled with liquid) before starting.
- If the pump will operate with a positive suction head, prime by opening the suction valve and allowing liquid to enter pump casing. Open air vents at this time, and make sure all air is forced from pump by liquid before closing.
- Rotate the shaft by hand to free entrapped air from impeller passageways.
- If pump has a suction lift, priming must be accomplished by other methods. The use of foot valves or ejectors, or manual filling of the pump casing and suction line with liquid are possible methods suggested for this purpose.
- CAUTION: Never run the pump dry in the hope that it will prime itself! Serious damage to the mechanical seal will result.

**Caution**

***Never run the pump dry in the hope that it will prime itself! Serious damage to the shaft seals, pump wear rings and shaft sleeves will result.***

### 5.2 Pre-start checklist



**Warning**

***In the interest of operator safety, the unit must not be operated above the nameplate conditions. Such operation could result in unit failure causing injury to operating personnel. Consult instruction book for proper operation and maintenance of the pump and its supporting components.***

Make the following inspections before starting your PACO Type L pump:

1. Make sure the suction and discharge piping has been cleaned and flushed to remove dirt and debris before operating pump.
2. Double check rotation must be clockwise operating in reverse will destroy the impeller and shaft.
3. Make sure all wiring connections to the motor (and starting device) match the wiring diagram and produce clockwise rotation as viewed from the back of the motor.
4. If the motor has been in storage for an extended length of time, either before or after installation, refer to motor instructions before starting.
5. Check the voltage, phase, and line circuit frequency with the motor nameplate. Turn rotating element by hand to make sure it rotates freely.
6. Tighten plugs in gauge and drain taps. If the pump is fitted with pressure gauges, keep gauge clocks closed when not in use.
7. Check suction and discharge piping for leaks, and make sure all flange bolts are securely tightened.

### 5.3 Motor rotation

**Caution**

***Never check driver rotation unless pump and driver couplings are disconnected and physically separated. Failure to follow this instruction can result in serious damage to pump and driver if rotation is wrong.***

After the unit has been wired and checked to insure that all components in the system (disconnect device, magnetic starters, pilot devices and motors) are properly connected, check motor rotation as follows:

- For 3 phase units only—momentarily energize the motors to ensure that the rotation is correct as indicated by the arrow cast into the pump volute. If rotation is incorrect, interchange two wires at the motor starter terminals T1 and T2.
- IMPORTANT: The pumps must not be operated while dry. Use extreme caution that motors are energized only momentarily to determine proper rotation.

### 5.4 Starting the pump



**Warning**

***The pump must not be operated without an approved coupling guard in place. Failure to observe this warning could result in injury to operating personnel.***

1. Install coupling guard on coupled units.
2. Fully open gate valve (if any) in suction line, and close gate valve in discharge line.
3. Fill suction line with liquid and completely prime pump.
4. Start the motor (pump).
5. Immediately make a visual check of pump and suction piping for pressure leaks.
6. Immediately after pump reaches full operating speed, slowly open the discharge gate valve until complete system flow is achieved.
7. Check discharge piping for pressure leaks.
8. If pump is fitted with pressure gauges, open gauge cocks and record pressure reading for future reference. Verify that the pump is performing in accordance with parameters specified on performance curve.
9. Check and record voltage, amperage per phase, and kilowatts, if a wattmeter is available.

## 5.5 Voltage regulation

The motor will operate satisfactorily under the following conditions for voltage and frequency variation, but not necessarily in accordance with the standards established for operation under rated conditions:

- The voltage variation may not exceed 10 % above or below rating specified on the motor data plate.
- The frequency variation may not exceed 5 % above or below motor rating.
- The sum of the voltage and frequency variations may not exceed 10 % above or below motor rating, provided the frequency variation does not exceed 5 %.

## 5.6 Pump shutdown

The following shutdown procedures will apply in most normal shutdowns for the PACO Type L pumps. If the pump will be inoperative for an extended length of time, follow storage procedures in Extended Period Shutdown.

- Always close the discharge valve before stopping the pump. Close the valve slowly to prevent hydraulic shock.
- Cut and lock off power to the motor.

## 5.7 Short duration shutdown

- For overnight or temporary shutdown periods under non-freezing conditions, the pump may remain filled with liquid. Make sure the pump is fully primed before restarting.
- For short or frequent shutdown periods under freezing conditions, keep fluid moving within the pump casing and insulate or heat the pump exterior to prevent freezing.

## 5.8 Extended period shutdown

- For long shutdown periods, or to isolate the pump for maintenance, close suction gate valve. If no suction valve is used and the pump has positive suction head, drain all liquid from suction line to terminate liquid flow into pump suction nozzle. Remove plugs in pump drain and vent taps, as required, and drain all liquid from the pump volute casing.
- If freezing conditions will exist during long shutdown periods, completely drain the pump and blow out all liquid passages and pockets with compressed air. Freezing of pump liquid can also be prevented by filling the pump with antifreeze solution.

## 6. Maintenance



### Warning

**Do not attempt any maintenance, inspection, repair or cleaning in the vicinity of rotating equipment. Such action could result in personal injury to operating personnel.**

Before attempting any inspection or repair on the pump, the driver controls must be in the "OFF" position, locked and tagged to prevent injury to personnel performing service on the pump.

### 6.1 Motor lubrication

Always follow motor manufacturer's lubrication instructions if available, and periodically check grease fittings and drain plugs for leaks. If lubricating instructions do not accompany motor, refer to for recommended lubrication periods.

- To lubricate the motor while running or at rest, remove grease drain plug (if any) and filler plug on grease fitting. Grease with clean lubricant until grease appears at drain hole or along motor shaft.

#### Recommended Lubrication Periods

Motor RPM	Motor HP	Operating conditions		
		Standard	Severe	Extreme
1750 and below	0.33 - 7.50p	3 yrs	1 yr	6 mo
	10-40	1-3 yrs	6 mo - 1 yr	3 mo
	50-150	1 yr	6 mo	3 mo
	200 and up	1 yr	6 mo	3 mo
above 1750	all hp	6 mo	3 mo	3 mo

#### Standard conditions:

8 Hours per day operation, normal or light loading, clean air, 100 °F, maximum ambient temperature.

#### Severe conditions:

Continuous 24-hour operation, shock loading or vibration, poor ventilation, 100-150 °F, ambient temperature.

#### Extreme conditions:

Continuous operation, heavy shock or vibration, dirt or dust in air, extreme ambient temperature.

- One-half to one cubic inch of grease is sufficient for motors 5 HP and under, with proportionately more grease for greater HP motors.
- Most fractional and some integral frame motors have "sealed-for-life" bearings, and do not require further lubrication throughout motor life.
- Always follow motor manufacturer's lubrication instructions, and periodically check grease fittings and drain plugs for leaks.
- If lubricating instructions do not accompany motor, refer to Table , "Recommended Lubrication Periods," on page 10 for recommended lubrication periods.
- Table , "Approved lubricants," on page 11 lists recommended types of grease for both pump and motor lubrication. These types have all been thoroughly tested and should be used whenever possible.

## 6.2 Pump lubrication

- PACO Type LF pumps on horizontal bearing frames have bearing that may be sealed for life (requiring no lubrication), regreasable or oil lubricated.

Approved lubricants	
MANUFACTURER	LUBRICANT
SHELL	DOLIUM® R
EXXON	POLYREX®
CHEVRON	SRI GREASE NLGI 2
	BLACK PEARL - NLGI 2
PHILIPS	POLYTAC™
TEXACO	POLYSTAR RB

- To lubricate regreasable bearings, remove grease drain plug (if any) and filler plug. Add clean ball bearing lubricant until grease appears at drain hole or along shaft. On units with drain hole, all old grease can be purged out ahead of new. In such cases, the drain should be left unplugged for several minutes during pump operation to allow excess grease to be forced out.
- Lubricate bearing frame bearings at intervals of one to three months, depending on severity of environment. Pumps in a clean, dry, moderate temperature (100 °F maximum) environment should be regreased at three month intervals. Too much grease can cause premature bearing failure-do not overgrease.
- On those PACO Type LF Centrifugal End Suction pumps ordered with oil lubricated bearings, Fig. 7. A regular oil maintenance program must be enforced. Pumps with oil lubricated bearings are fitted with a transparent reservoir (constant level oiler) that maintains oil level about the centerline of the bearing. When necessary, the oil supply in the reservoir of the constant level oiler must be renewed.
- After the first 200 hours of operation the oil should be changed. To change the oil, remove the drain plug at the bottom of the bearing cover and the filler plug (that also acts as a vent plug) at the top of the housing. After draining oil, replace the fittings and refill with an acceptable oil selected from Table , "List of acceptable Lube oils," on page 11. After the first oil change, the oil should be changed again at 2000 hours and then at intervals of 8000 hours or once yearly, thereafter.

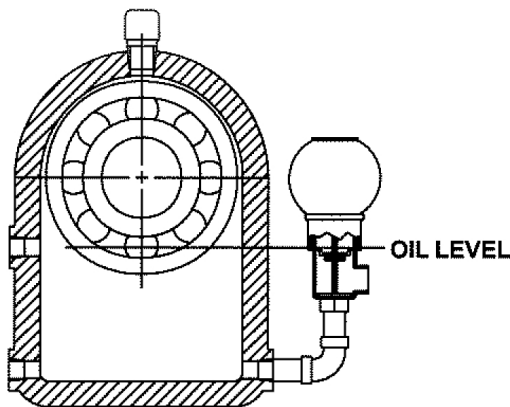

Fig. 7

TM05 4793 2613

List of acceptable Lube oils	
Lubricant Manufacturer	Bearing oil brand name
Aral Refining Co.	Aral Oil CMU
	Aral Oil TU 518
British Petroleum Co.	BP Energol
	TH 100-HB
Calypsol Oil Co.	Calypsol Bison Oil
	SR 25 or SR 36
Standard Oil Co.	Chevron
	Hydraulic Oil 11
Esso Corp	Circulating oil 45
	Esso-Mar 25
	Teresso 47
Fina Oil Co.	Esstic 50
	Fina hydran 34
Gulf Refining Co.	Fina Cirkan 32
	Gulf Harmony 47
Socony Mobil Oil Co.	Gulf Paramount 45
	Vac hlp 25
Shell Oil Co.	Mobulix D.T.E. 25
	Shell Tellus oil 29
Sundco Oil Co.	Sunvis 821
	Texaco ursa oil P 20
The Texas Co.	Dea viscobil sera 4
	Wisura norma 25 (36)
Wisura Refining Co.	Wisura tempo 25 (36)

### 6.3 Disassembly of pumps



**Warning**

*Depending on the product being pumped, the pump should be washed down before any work is done on it.*

**Warning**



*Observe extreme caution when venting and/or draining hazardous liquids. Wear protective clothing in the presence of caustic, corrosive, volatile, flammable, or hot liquids. DO NOT breathe toxic vapors. DO NOT allow sparking, flames, or hot surfaces in vicinity of the equipment.*

1. Complete disassembly instructions are outlined below. Proceed only as far as required to perform the maintenance work needed.
2. Turn off power.
3. Drain System. Flush, if necessary.
4. Closed coupled units. Remove motor hold down bolts.

#### 6.3.1 Disassembly of liquid end

1. Remove casing bolts (8B).
2. Remove back pull-out bearing frame assembly (20Y) from casing (1A).
3. Unscrew impeller nut (8A).

**Do not screwdriver between impeller vanes to prevent rotation. It may be necessary to use a strap wrench around the impeller or shaft to prevent rotation.**

**Caution**

4. Use appropriate size gear puller aligned behind impeller vanes to remove impeller (3A) from shaft (6A).
5. Remove impeller key (12A).
6. Remove back plate bolts (8D). Remove back plate (2K) and seal housing (26P).
7. Place seal housing on flat surface and press out seal seat (14A).
8. If shaft sleeve (5A) requires replacement, it must be evenly heated to approximately 350 °F to loosen locktite. Twist sleeve off shaft (6A).

#### 6.3.2 Disassembly of bearing frame (LF)

1. Remove slinger (13G).
2. Remove grease seal(s), (14S) if any.
3. Remove bearing house retaining ring (61K).
4. Press or tap on the pump end of the bearing-shaft assembly until one bearing is out.
5. When one bearing is out, remove second retaining ring (61F), then remove complete assembly from bearing housing.
6. Remove shaft retaining ring (61C) and press off bearings.
7. Press on new bearings, remember to press only on inner race of bearing while pressing them on.
8. Assemble frame in the reverse procedure used for disassembly.
9. Observe the following when reassembling the bearing frame.
10. Replace lip seals (14S) if worn or damaged.
11. Replace bearings (18A), (18B) if loose, rough or noisy when rotated.
12. Check shaft (6A) for runout at the sleeve (5A) area. Maximum permissible is .002" T.I.R.

### 6.4 Seal replacement (LCS)

1. Complete preparations noted.
2. Remove coupling guard (34F).
3. Remove coupling bolts (8E). Pry apart the coupling halves (23D), remove keys (12B) and set aside.

**Note**

**Mark or measure the original position of the pump coupling on the motor side.**

4. Unscrew tubing connector from pipe tee of air vent assembly. Pipe dope is applied to threads during factory assembly, and resulting bond may retard but will not prevent manual disassembly.
5. Remove seal cap bolts and slide seal cap (2N) up shaft to remove.
6. Remove seal head assembly manually from shaft (6A). Water-soluble lubricant may be applied to shaft to ease removal of shaft seal (14A). Pull seal head assembly manually from shaft, using slight twisting motion (as necessary) to loosen bellows from shaft.
7. Remove and discard seal spring and retainer.
8. Remove and discard seal seat from seal cap (2N) and thoroughly clean the inside cavity of seal cap.
9. Interior surface of bellows on new seal head is coated with bonding agent that adheres to motor shaft. When old seal head is removed, bonding agent no longer exists and bellows may crack or split during removal. Installation of new mechanical seal is always recommended if it becomes necessary to remove existing seal from shaft.
10. Clean and lubricate shaft (6A) with water-soluble lubricant and make sure no sharp edges exist to cut or scratch bellows of new seal.
11. Press new seal seat firmly into seal cap. Avoid direct contact of seal face with metallic or abrasive objects and wipe clean after installation to ensure abrasive free sealing surface.
12. Slide new seal head assembly onto shaft by applying even pressure to base of assembly.
13. Install seal cap (2N) down shaft.
14. See reassembly instructions.

### 6.5 Wear ring replacement

1. Complete preparations.
2. Back-pull rotating assembly.
3. It may be necessary to remove volute (1A) from piping, to facilitate easy access to interior of volute. If necessary, remove flange bolts at piping.
4. To remove worn Case Wear Ring (4A), drill two holes slightly smaller than width of ring into exposed edge of ring. Once holes are drilled, a chisel may be used to completely sever ring at holes and break ring into two halves for easy removal.
5. Clean the ring cavity in the volute prior to installing wear ring to ensure a properly aligned fit.
6. To reassemble, press fit new wear ring squarely into volute casing cavity. Ring may be tapped into place to make sure it is completely impressed into cavity.

**Caution**

**Do not use metal tooling against wear ring surfaces. Use only rubber, rawhide, wood or other soft material to prevent damage to ring.**

## 6.6 Reassembly of pumps

1. All parts should be cleaned before reassembly.
2. Refer to parts list to identify required replacement items  
Specify pump serial or catalog number when ordering parts.
3. Reassembly is the reverse of disassembly.
4. Observe the following when reassembling the liquid end:
  - All mechanical seal components must be in good condition or leakage may result. Replacement of complete seal assembly is recommended.
  - New shaft sleeves are installed by bonding to shaft with hydraulic setting locktite.
5. Re-install coupling guards on coupled pumps.



### **Warning**

***Coupling guard must be reinstalled and in place prior to operation.***

## 6.7 Ordering parts

Grundfos Pumps has over 90 years of experience in the design, manufacture, and application of centrifugal pumps and pumping systems. Grundfos's commitment to state-of-the-art pump design and quality manufacturing assures maximum user benefits with optimum equipment life at lower cost.

Grundfos's commitment to their customers continues through an extensive service organization. Highly trained technicians can assist customers with initial startup, troubleshooting, repair, and system analysis.

PACO maintains an extensive stock of replacement parts and parts kits for our most popular model pumps. Shipment of these parts is normally made within three days after receipt of an order. On larger pumps, where it is impractical for our factory to inventory low usage parts, replacement parts are normally manufactured and shipped within 15 working days of receipt of an order. In order to reduce pump repair time and shorten inconvenient pump service interruptions, it is suggested that the pump user stock spare parts. For suggested spare parts see Replacement Parts Guide A1b.2, attached, and contact your local PACO Sales Representative (see back cover for the number of your nearest PACO Sales office). Since spare parts requirements and quantities vary for specific pump constructions, allow your PACO Representative to help in defining your spare part requirements. To ensure that the proper replacement parts are ordered for your particular pump model, when you call:

- Identify all pertinent data from the pump name plate (see Pump Identification ). This should always include the pump Catalog or Model Number, and the pump Serial Number.
- For replacement impellers, also include from the nameplate the operating conditions (GPM and TDH) and the impeller diameter.
- Identify all parts by item number and description as indicated by the appropriate assembly drawing in this manual, for your particular pump model.

6.8 Type LF, cross section and parts list

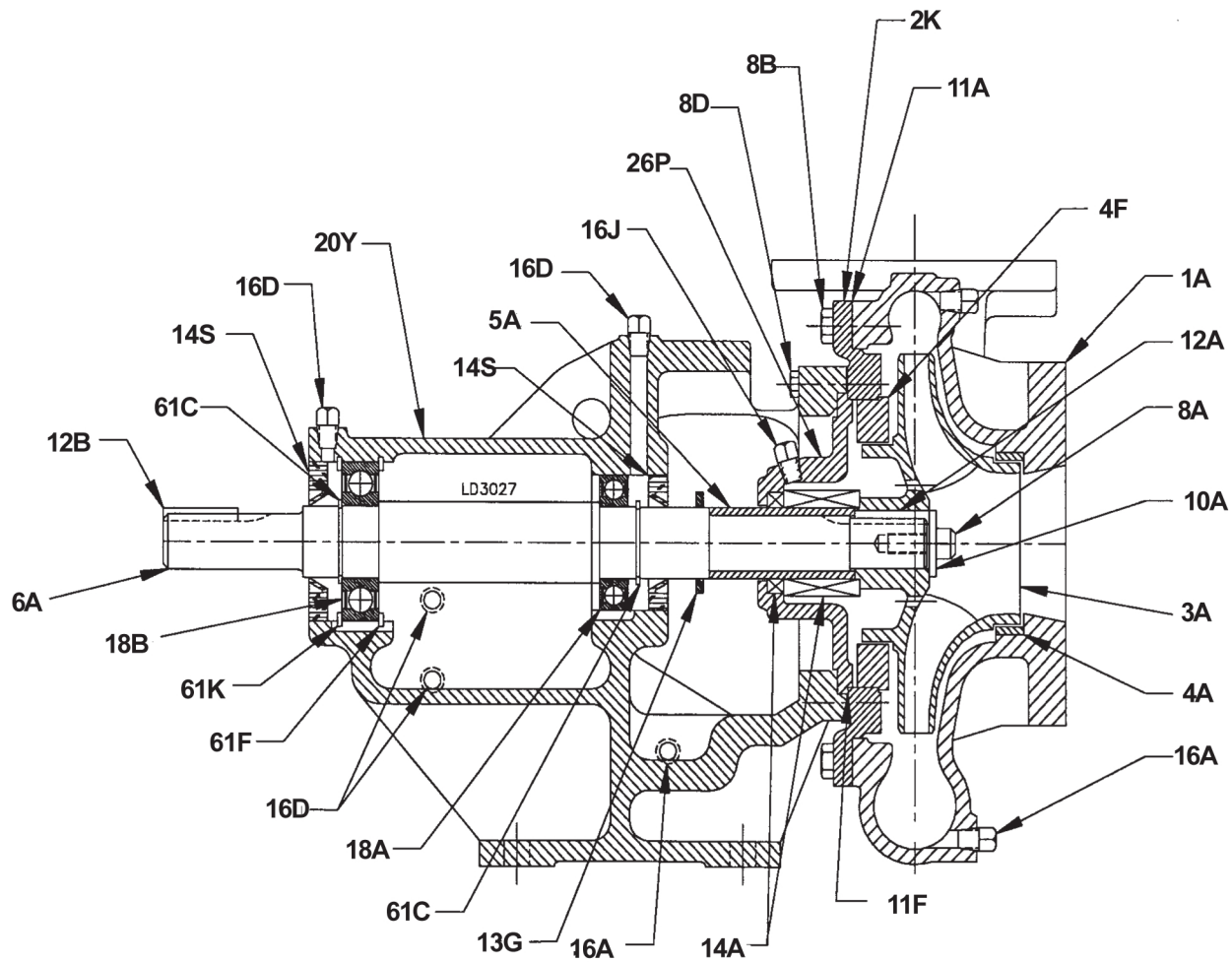

TM05 4796 3712

ITEM NO	PART NAME	ITEM NO	PART NAME	ITEM NO	PART NAME
1A	Casing	*10A	Washer, Packing	16L	Plug, Seal Chamber
2K	Backplate	10A	Washer, Impeller	18A	Bearing, Inboard
3A	Enclosed Impeller	11A	Gasket, Casing	18B	Bearing, Outboard
4A	Case Wear Ring	11F	Gasket, Backplate	20Y	Bearing Frame
**4F	Balance Ring	12A	Key, Impeller	*22A	Stud, Packing Gland
5A	Shaft Sleeve	12B	Key, Coupling	26P	Seal Housing
*5L	Lantern Ring	*13A	Packing	*26U	Packing Box
6A	Shaft	13G	Slinger	*35F	Nut, Packing Gland
*7A	Packing Gland	14A	Shaft Seal	61C	Snap Ring
8A	Cap Screw, Impeller	14S	Lip Seal	*61J	Snap Ring
8B	Cap Screw, Casing	16A	Plug, Drain		
8D	Cap Screw, Brg. Frame	16D	Plug, Grease/Oil Filter		

\* Packed Pumps Only

\*\* If Applicable



6.10 Type LCV, cross section and parts list

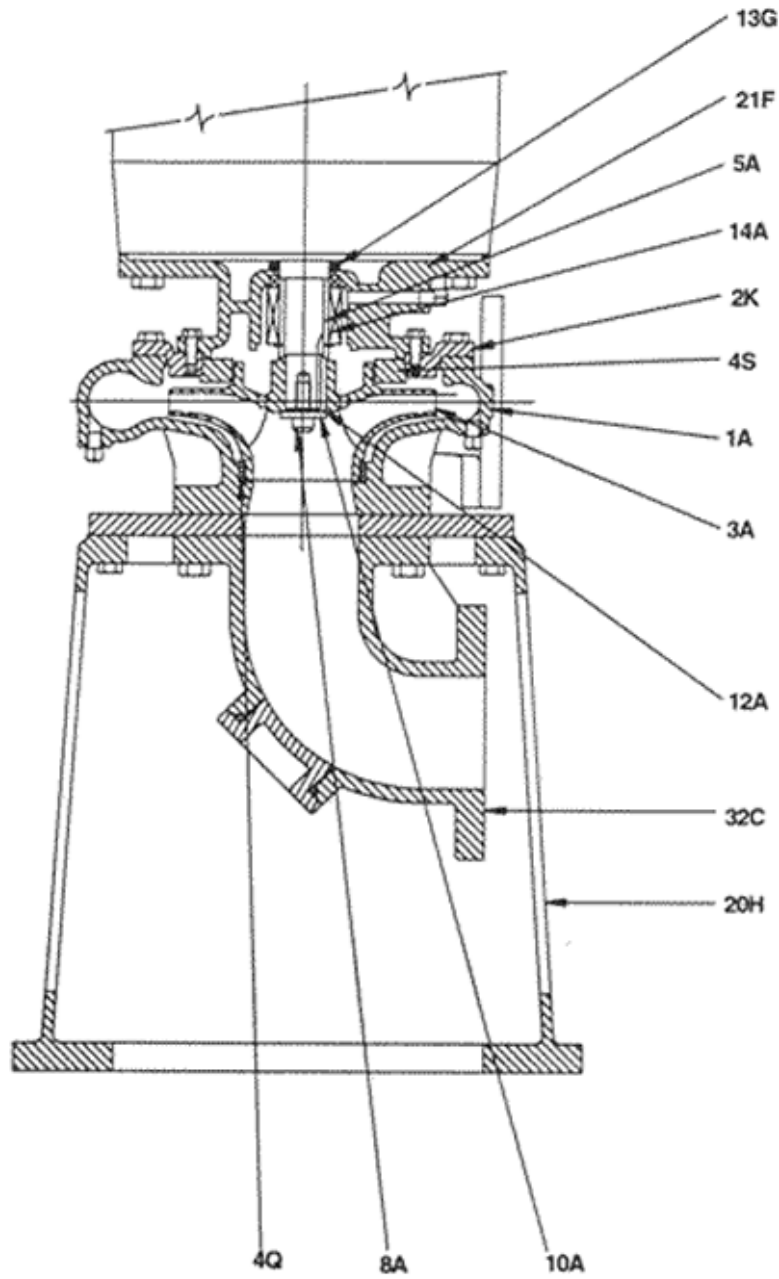

TM05 8910 2913

ITEM NO	PART NAME	ITEM NO	PART NAME
1A	Volute	10A	Impeller washer
2H	Hand hole cover (not shown)	12A	Key
2K	Backplate	13G	Slinger
3A	Impeller	14A	Single mechanical seal assembly
4Q	Suction cover wear ring	20H	Stand
4S	Impeller wear ring	21F	Pedestal bracket
5A	Sleeve	32C	Elbow with clean out port
8A	Impeller screw		



6.11 Type LCS, cross section and parts

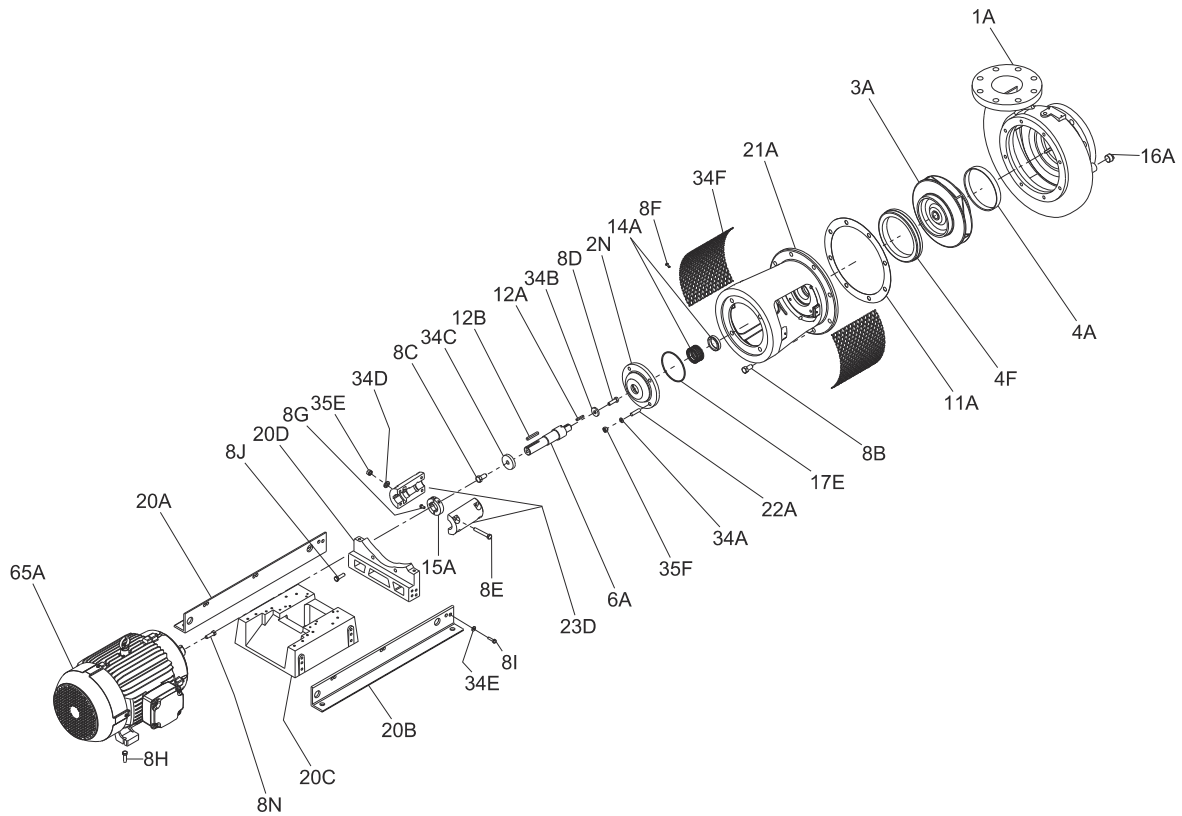

TM06 1700 2614

ITEM NO	PART NAME	ITEM NO	PART NAME
1A	VOLUTE	17E	SEAL CAP O-RING
2N	SEAL CAP	20B	BASE RAIL
3A	IMPELLER	20C	MOTOR DECK
4A	CASE WEAR RING	20J	CAST IRON STAND
4F	BALANCE RING	20D	PUMP SUPPORT
6A	PUMP SHAFT	21A	MOTOR BRACKET
8B	VOLUTE SCREW	22A	SEAL CAP STUDS
8C	PUMP SHAFT SCREW	23D	COUPLING HALVES
8E	COUPLING SCREW	24H	BUSHING
8F	COUPLING GUARD SCREW	34B	IMPELLER WASHER
8G	LOCATING RING SCREW	34C	PUMP SHAFT WASHER
8N	MOTOR SCREW	34D	COUPLING WASHER
11A	VOLUTE GASKET	35E	COUPLING NUT
12B	COUPLING KEY	34F	COUPLING GUARD
14A	SEAL ASSEMBLY	35F	SEAL CAP NUT
15A	LOCATING RING	65A	MOTOR
16A	PIPE PLUG		

## 7. Trouble Shooting

### 7.1 Symptom

Symptoms	Cause Code
Pump does not deliver any liquid at start-up.	1*2*3*4*5*6*7*8*9*10*11*14*16*17*22*23*24*34
Pump stops delivering liquid after start-up.	2*3*4*5*6*7*8*9*10*11*12*13*22*23*24*34
Pump overheats and/or ceases to deliver liquid.	1*3*9*10*11*21*22*27*29*30*31*33*34*40*41
Insufficient flow rate.	2*3*4*5*6*7*8*9*10*11*14*16*17*20*21*22*23*24*25*26*34
Excessive flow rate.	15*18*20*34
Discharge pressure is too high.	4*14*16*18*20*22*23*24*25*26*34
Shaft seal leaks appreciably, or the packing leaks excessively.	27*28*29*30*33*34*35*36*39*41
Shaft seal or packing fails prematurely.	12*13*27*28*29*30*33*34*35*36*37*38*39*41
Pump uses too much power.	15*16*18*19*20*23*25*27*28*31*33*34*35*37*38*44
Pump runs rough and noisily.	2*3*4*5*6*7*8*9*10*11*15*17*18*21*23*24*27*28*29*30*31*32*33*34*40*41*42*45*46*
Bearings overheat and/or fail prematurely.	27*28*29*30*31*32*33*34*40*41*42*43*44*45*46

### 7.2 Possible Causes

1. The pump has not been properly bled of air.	25. The casing and impeller wear rings may be excessively worn.
2. The pump suction line have not been completely primed.	26. There may be internal leakage from the discharge to the suction compartments as the result of internal gasket failure.
3. The suction head (NPSHR) required by the pump is too high, or the net positive suction head available (NPSHA) at your facility is too low.	27. There may be a misalignment of the pump shaft.
4. The fluid pumped contains too much entrained air or gas.	28. The shaft may chatter because it is bent.
5. There are air pockets in the suction line.	29. The pump may run rough due to improper balancing of the impeller.
6. An entry of air has suddenly occurred in the suction line.	30. The shaft may not be running due to worn bearings.
7. An entry of air past the shaft seal into the pump has occurred.	31. The impeller may be rubbing against the inside of the case.
8. The inlet of the suction line is insufficiently submerged.	32. The concrete pad might not be of sufficient size to provide pump stability.
9. The suction valve is closed or only partially open.	33. The pump may have become misaligned during Installation.
10. The suction strainer is clogged with dirt or debris.	34. The operating conditions of the installation do not agree with the data specified when the pump was purchased.
11. The foot valve is clogged or undersized.	35. The shaft seal may be incorrectly installed, or the stuffing box has not been packed correctly.
12. Little or no cooling fluid supplied to the shaft seals.	36. The shaft sleeve may be scored or pitted in the region of the packing due to dirt or abrasive matter in the flushing fluid.
13. The lantern ring is not positioned opposite the flushing inlet thereby restricting fluid flow.	37. Excessive tightening of the packing gland may block the flushing port thereby diminishing the sealing fluid flow.
14. Pump drive rotational speed too low.	38. Packing material may have become wedged or extruded between the shaft and the bottom of the stuffing housing due to excessive clearance on the packing backup washer.
15. Pump drive rotational speed too high.	39. The mechanical seal may have been damaged by running dry.
16. Pump rotation wrong or impeller installed backwards.	40. There may be excessive axial thrust (side loading) due to improper impeller central alignment.
17. Total head of installation (back Pressure) higher than rated total head of the pump.	41. The bearings may be worn.
18. Total head of installation (back Pressure) lower than rated total head of the pump.	42. The bearings may have been damaged during installation and/or dirt or other foreign matter may have entered the bearings during greasing or oiling.
19. Density of fluid pumped differs from that specified when the pump was purchased.	43. Excessive greasing may cause the bearings to overheat.
20. Viscosity of fluid pumped differs from that specified when the pump was purchased.	44. Inadequate lubrication may be causing bearing failure.
21. The pump is operating at too low a rate of flow (The discharge valve may be throttled too much).	45. Dirt may have entered the bearings past the O-Rings.
22. If pumps are operating in parallel, the pump characteristics may not be suitable for parallel operation.	46. Moisture may have entered the bearing housing causing the bearings to rust.
23. The impeller may be clogged with debris.	
24. The impeller may be damaged.	

**Grundfos CBS Inc.**  
902 Koomey Road  
Brookshire, TX 77423 USA  
Phone: 281-994-2700  
Toll Free: 1-800-955-5847  
Fax: 1-800-945-4777

[www.grundfosexpresssuite.com](http://www.grundfosexpresssuite.com)

<b>98522862</b> 0614
ECM: 1138324

The name Grundfos, the Grundfos logo, and be think innovate are registered trademarks owned by Grundfos Holding A/S or Grundfos A/S, Denmark. All rights reserved worldwide. © Copyright Grundfos Holding A/S