

**STA-RITE®**

**INSTALLATION AND OPERATING INSTRUCTIONS  
 REPAIR PARTS LIST**

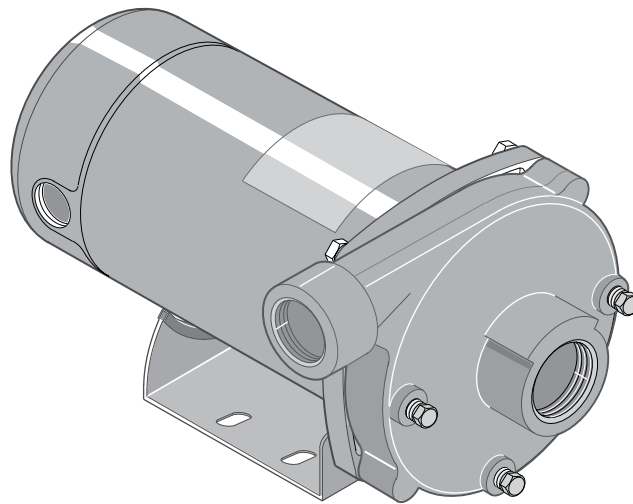

671 0294

MODELS								
HP	MEDIUM HEAD MODELS				HIGH HEAD MODELS			
1/3	JBMB-56S	-	JMB-56L	-	JBHB-61S	-	JHB-61HL	-
1/2	JBMC-56S	JBMC3-56S	JMC-56L	JMC3-56	JBHC-61S	JBHC3-61S	JHC-61HL	JHC3-61H
3/4	JBMD-57S	JBMD3-57S	JMD-57L	JMD3-57	JBHD-62S	JBHD3-62S	JHD-62HL	JHD3-62H
1	JBME-58S	JBME3-58S	JME-58L	JME3-58	JBHE-63S	JBHE3-63S	JHE-63HL	JHE3-63H
1-1/2	JBMF-40S	JBMF3-40S	JMF-40L	JMF3-40	JBHF-51S	JBHF3-51S	JHF-51HL	JHF3-51H
2	JBMG-41S	JBMG3-41S	JMG-41L	JMG3-41	JBHG-52S	JBHG3-52S	JHG-52HL	JHG3-52H
2-1/2	JBMMG-59S	JBMMG3-59S	-	-	JBHHG-53S	JBHHG3-53S	JHHG-53HL	JHHG3-53H

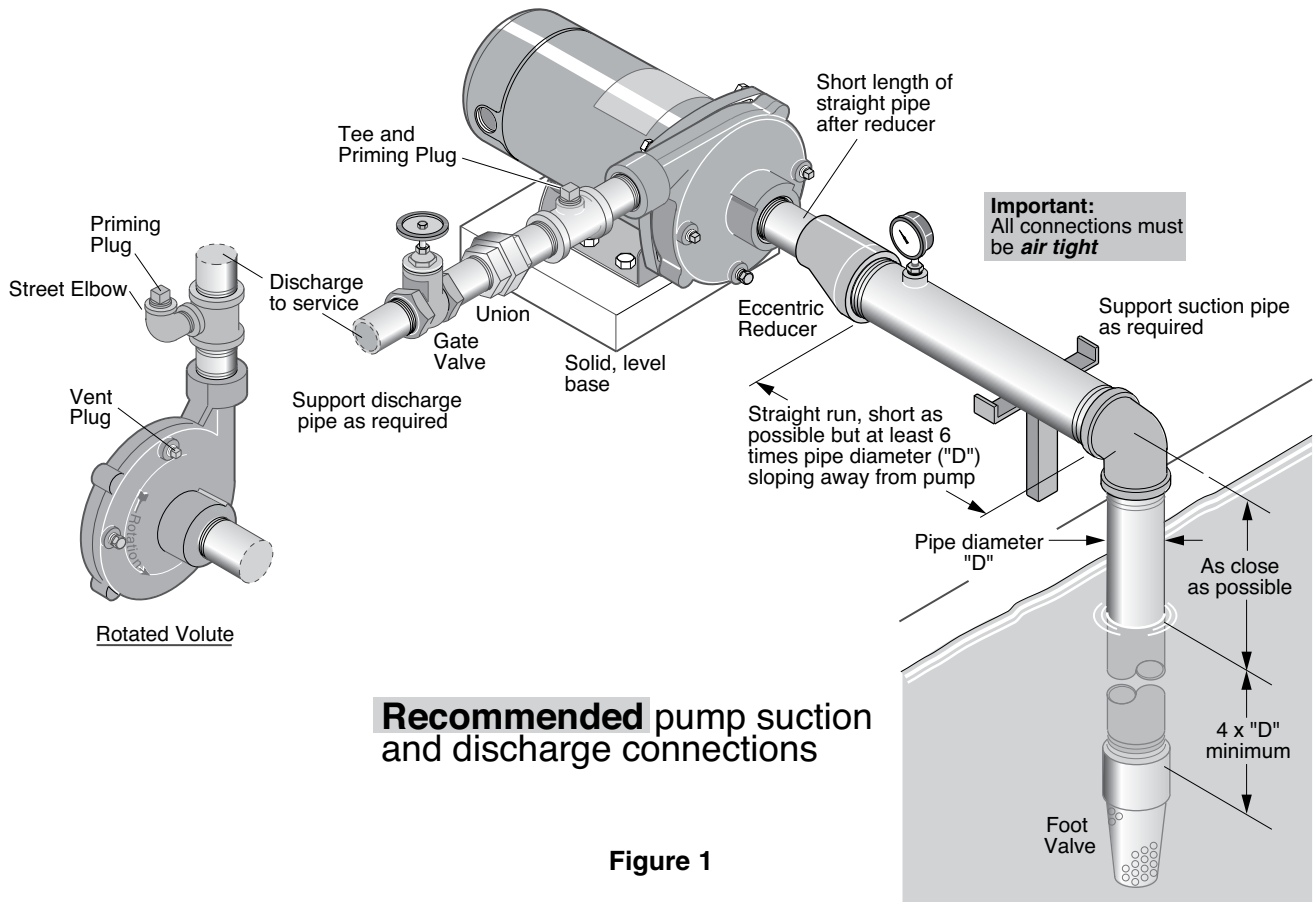

Figure 1

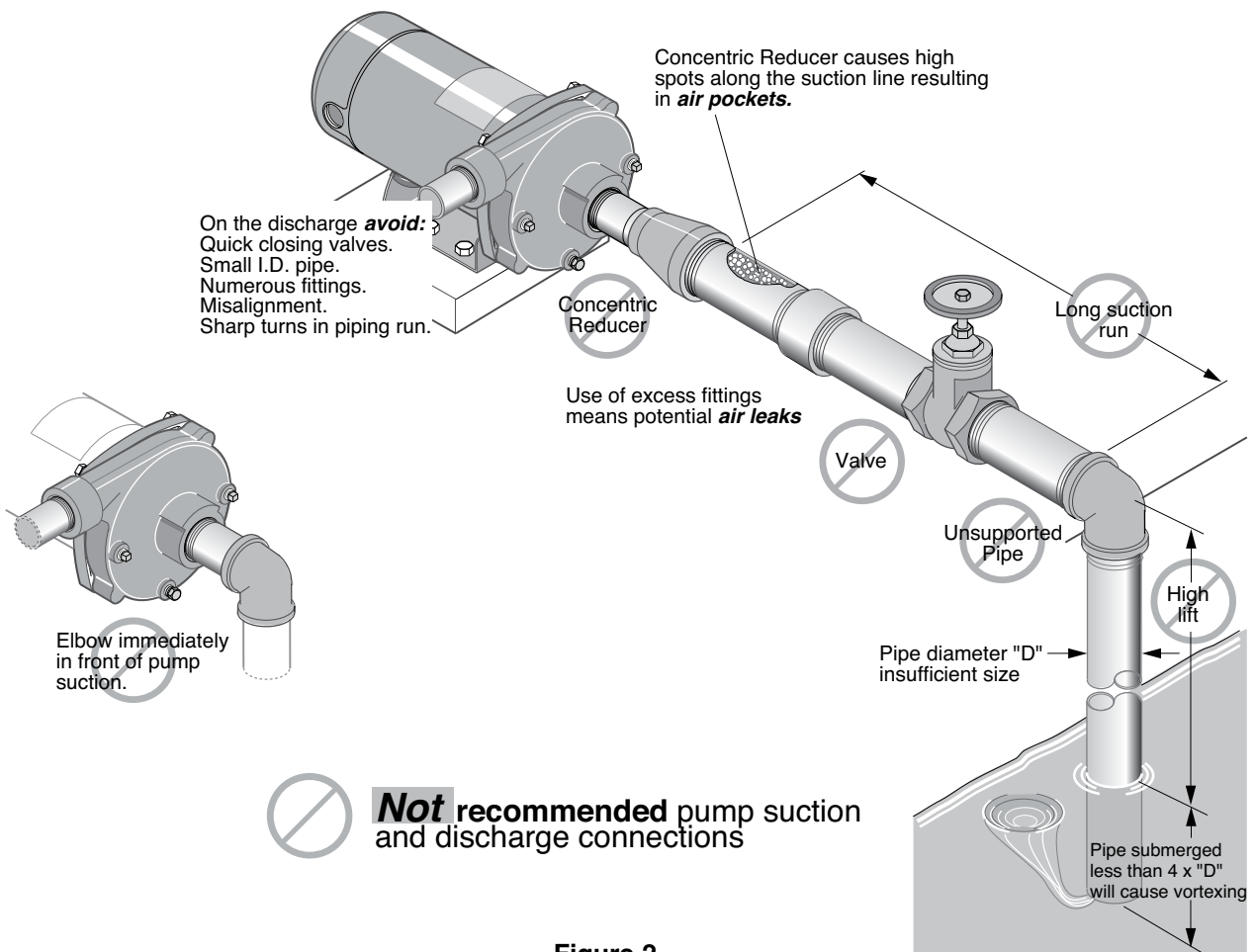

Figure 2

### California Proposition 65 Warning

**▲ WARNING** This product and related accessories contain chemicals known to the State of California to cause cancer, birth defects or other reproductive harm.

### PIPING - GENERAL

Support both suction and discharge piping independently at a point near the pump to avoid putting a strain on the pump housing. Start all piping **AT THE PUMP**.

Increase pipe diameter at both the suction and discharge by one (1) standard pipe size (minimum) to obtain desired performance and flow rate. Refer to Table I when sizing pipe for your pumping system.

**NOTICE:** Do not use pipe with **smaller** diameter on the suction side of pump.

**TABLE I**

Pipe Tapping Size On Pump		Recommended Pipe Size	
Suction	Discharge	Suction	Discharge
1-1/4	1	1-1/2	1-1/4
1-1/2	1-1/4	2	1-1/2
2	1-1/2	3	2

### SUCTION PIPE

Increase pipe size from pump tapping as shown in Table I.

Figure 1 (Page 2) depicts a recommended run of pipe and fittings for the suction side of a centrifugal pump. Please refer to this illustration when choosing pipe and fittings for your suction connection.

**IMPORTANT:** All connections must be air tight!

Figure 2 (Page 2) depicts conditions that are **NOT DESIRABLE** on the suction side of a centrifugal pump and may cause problems in flow rate and priming. Please look this illustration over carefully before choosing pipe and fittings for your suction connection.

### DISCHARGE PIPING

Increase pipe size from pump tapping as show in Table I. Figure 1 (Page 2) depicts a recommended run of pipe and fittings for the discharge. Install tee with priming plug as close to pump as possible. Figure 2 (Page 2) notes conditions that should be avoided. Please read over carefully before making discharge connection.

### PRIMING THE PUMP

A pump is primed when all air in the suction line and pump volute has been evacuated and replaced with water.

**To Prime:**

1. Close valve in discharge line.
2. Remove priming plug from tee and fill pump and suction line with water until water is flowing back out of tee.
3. Replace priming plug.
4. Start pump and slowly open valve until desired water flow is achieved.

**NOTICE:** If water is not being pumped, turn off pump, close valve, and repeat steps 1 thru 4.

If pump volute is rotated as shown in Figure 1 (Page 2), loosen vent plug when priming to evacuate air trapped inside volute and tighten when volute is completely filled with water.

**▲ WARNING** **Risk of explosion and scalding.** Never run pump against closed discharge. To do so can boil water inside pump, causing hazardous pressure buildup and possible explosion.

**▲ CAUTION** **Risk of flooding.** Do not run the pump dry. This will damage mechanical seal and void warranty. It may cause burns to person handling pump.

**▲ CAUTION** **Motor normally operates at high temperature and will be too hot to touch.** It is protected from heat damage during operation by an automatic internal cutoff switch. Before handling pump or motor, stop motor and allow it to cool for 20 minutes.

**TABLE II - RECOMMENDED FUSING AND WIRING DATA - 60 CYCLE MOTORS**

MOTOR HP	MAX. LOAD AMPERES	BRANCH FUSE* RATING AMPS	DIAMETER IN FEET FROM MOTOR TO METER					
			0' TO 50'	51' TO 100'	101' TO 200'	201' TO 300'	301' TO 400'	401' TO 500'
			WIRE SIZE					
<b>SINGLE PHASE - 115/230 VOLT</b>								
1/3	9.4/4.7	15/15	14/14	14/14	10/14	10/14	6/14	6/12
1/2	9.4/4.7	15/15	14/14	14/14	10/14	10/14	6/14	6/12
3/4	12.2/6.1	20/15	12/14	12/14	10/14	8/14	6/12	6/12
1	14.8/7.4	20/15	12/14	12/14	8/14	6/14	6/12	4/10
1-1/2	19.2/9.6	25/15	10/14	10/14	8/14	6/12	4/10	4/10
2	24.0/12.0	30/15	12/14	10/14	6/14	6/12	4/10	4/10
<b>THREE PHASE - 230/460 VOLT</b>								
1/2	2.3/1.15	15/15	14/14	14/14	14/14	14/14	14/14	14/14
3/4	3.1/1.55	15/15	14/14	14/14	14/14	14/14	14/14	14/14
1	3.6/1.8	15/15	14/14	14/14	14/14	14/14	14/14	14/14
1-1/2	4.7/2.35	15/15	14/14	14/14	14/14	14/14	14/14	14/14
2	6.8/3.4	15/15	14/14	14/14	14/14	14/14	12/14	12/14
2-1/2	8.5/4.25	15/15	14/14	14/14	14/14	14/14	12/14	10/14

\* Time delay fuse or circuit breakers are recommended in any motor circuit.

# ELECTRICAL

Connection diagram for dual voltage, single-phase motors. Your dual-voltage motor's terminal board (under the motor end cover) will match one of the diagrams below. Follow that diagram if necessary to convert motor to 115 Volt power. Connect power supply wires to L1 and L2. For 3-phase motors, or if motor does not match these pictures, follow the connection diagram on the motor nameplate.

## THE MOTOR IS SET FOR 230 VOLTS WHEN SHIPPED.

To change the motor to use 115 volts:

1. Turn off power
2. Remove the back motor cover.
3. Use a screwdriver or 1/2" wrench and turn the voltage selector dial counterclockwise until 115 shows in the dial opening.
4. Reinstall the motor cover.

**⚠ WARNING** Hazardous voltage. Can shock, burn, or cause death. Disconnect power to motor before working on pump or motor. Ground motor before connecting to power supply.

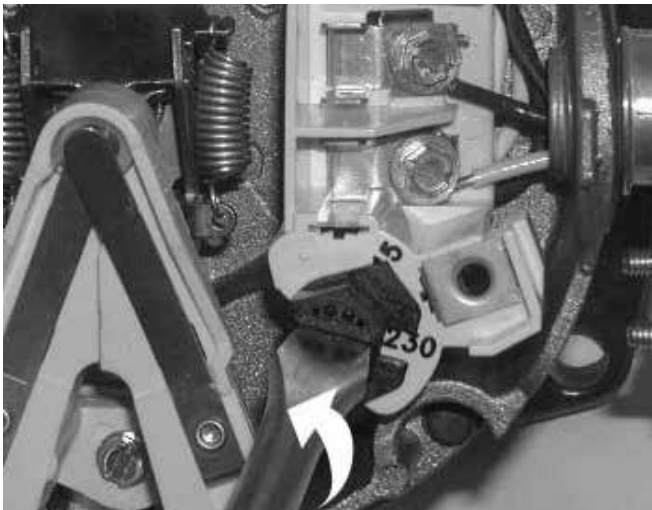

Figure 3: Changing the Voltage Setting



Figure 4: Motor Set for 115 Volt Operation

## WIRING

**⚠** Ground motor before connecting to electrical power supply. Failure to ground motor can cause severe or fatal electrical shock hazard.

**⚠** Do not ground to a gas supply line.

**⚠** To avoid dangerous or fatal electrical shock, turn OFF power to motor before working on electrical connections.

**⚠** Supply voltage must be within  $\pm 10\%$  of nameplate voltage. Incorrect voltage can cause fire or damage motor and voids warranty. If in doubt consult a licensed electrician.

**⚠** Use wire size specified in Wiring Chart (Page 3). If possible, connect pump to a separate branch circuit with no other appliances on it.

**⚠** Wire motor according to diagram on motor nameplate. If nameplate diagram differs from diagrams above, follow nameplate diagram.

1. Install, ground, wire and maintain your pump in compliance with the National Electrical Code (NEC) in the U.S., or the Canadian Electrical Code (CEC), as applicable, and with all local codes and ordinances that apply. Consult your local building inspector for code information.
  2. Provide a correctly fused disconnect switch for protection while working on motor. For switch requirements, consult your local building inspector for information about codes.
  3. Disconnect power before servicing motor or pump. If the disconnect switch is out of sight of pump, lock it open and tag it to prevent unexpected power application.
  4. Ground the pump permanently using a wire of the same size as that specified in wiring chart (Page 3). Make ground connection to green grounding terminal under motor canopy marked GRD. or  $\text{Ⓧ}$ .
  5. Connect ground wire to a grounded lead in the service panel or to a metal underground water pipe or well casing at least 10 feet long. Do not connect to plastic pipe or insulated fittings.
  6. Protect current carrying and grounding conductors from cuts, grease, heat, oil, and chemicals.
  7. Connect current carrying conductors to terminals L1 and L2 under motor canopy. When replacing motor, check wiring diagram on motor nameplate against Figure ##. If the motor wiring diagram does not match either diagram in Figure 3, follow the diagram on the motor.
- IMPORTANT:** 115/230 Volt single phase models are shipped from factory with motor wired for 230 volts. If power supply is 115 volts, remove motor canopy and reconnect motor as shown in Figure 3. Do not try to run motor as received on 115 volt current.
8. Motor has automatic internal thermal overload protection. If motor has stopped for unknown reasons, thermal overload may restart it unexpectedly, which could cause injury or property damage. Disconnect power before servicing motor.
  9. If this procedure or the wiring diagrams are confusing, consult a licensed electrician.

# SERVICE

## PUMP SERVICE

This centrifugal pump requires little or no service other than reasonable care and periodic cleaning. Occasionally, however, a shaft seal may become damaged and must be replaced. The procedure as outlined below will enable you to replace the seal.

**NOTICE: Pumps use mechanical seals with a rubber seat ring or a sealing O-Ring. THESE SEALS ARE COMPLETELY INTERCHANGEABLE.**

**NOTICE:** The highly polished and lapped faces of this seal are easily damaged. Read instructions and handle the seal with care.

Some models are equipped with an impeller screw, which has a left hand thread. Before unscrewing the impeller, remove the impeller screw.

### REMOVAL OF OLD SEAL

1. After unscrewing impeller, carefully remove rotating part of seal by prying up on sealing washer, using two screwdrivers (see Figure 5A). Use care not to scratch motor shaft.
2. Remove seal plate from motor and place on flat surface, face down. Use a screwdriver to push ceramic seat out from seal cavity (see Figure 5B).

### INSTALLATION OF FLOATING SEAT (Figure 5C)

1. Clean polished surface of floating seat with clean cloth.
2. Turn seal plate over so seal cavity is up, clean cavity thoroughly.
3. Lubricate outside rubber surface of ceramic seat with soapy water and press firmly into seal cavity with finger pressure. If seat will not locate properly in this manner, place cardboard washer over polished face of seat and press into seal cavity using a 3/4" socket or 3/4" piece of standard pipe.
4. **DISPOSE OF CARDBOARD WASHER.** Be sure polished surface of seat is free of dirt and has not been damaged by insertion. Remove excess soapy water.

### INSTALLATION OF ROTATING PART OF SEAL UNIT (Figure 5D)

1. Reinstall seal plate using extreme caution not to hit ceramic portion of seal on motor shaft.
2. Inspect shaft to make sure that it is clean.
3. Clean face of sealing washer with clean cloth.
4. Lubricate inside diameter and outer face of rubber drive ring with soapy water and slide assembly on motor shaft (sealing face first) until rubber drive ring hits shaft shoulder.
5. Screw impeller on shaft until impeller hub hits shaft shoulder. This will automatically locate seal in place and move the sealing washer face up against seat facing. Reinstall impeller screw (if used).

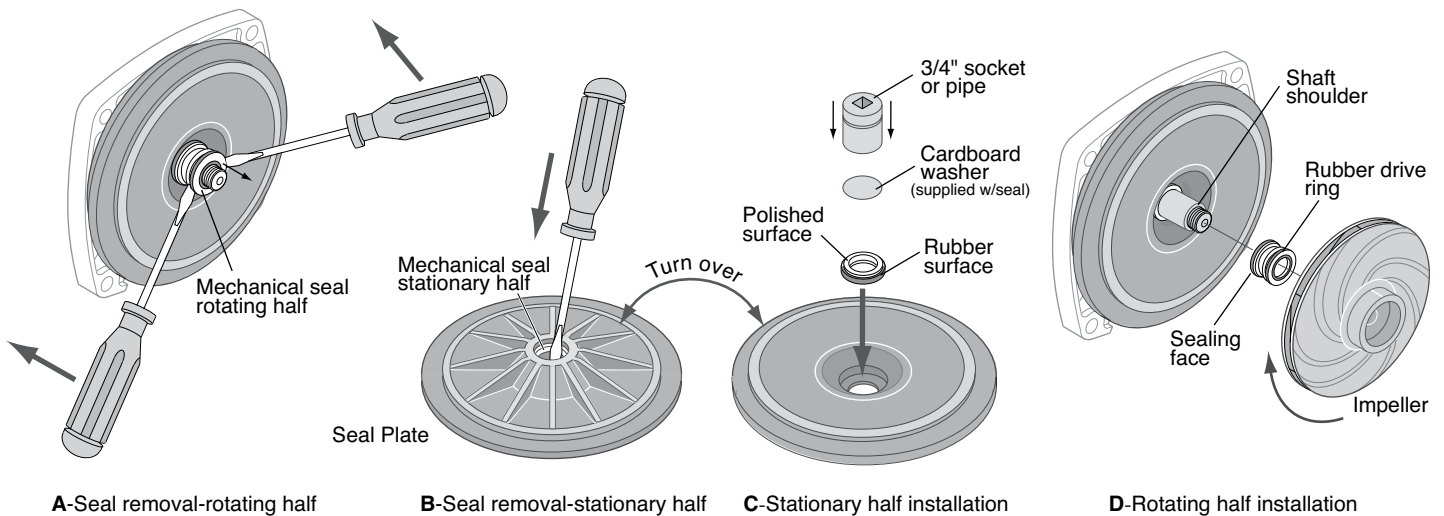

5939 0109

FIGURE 5

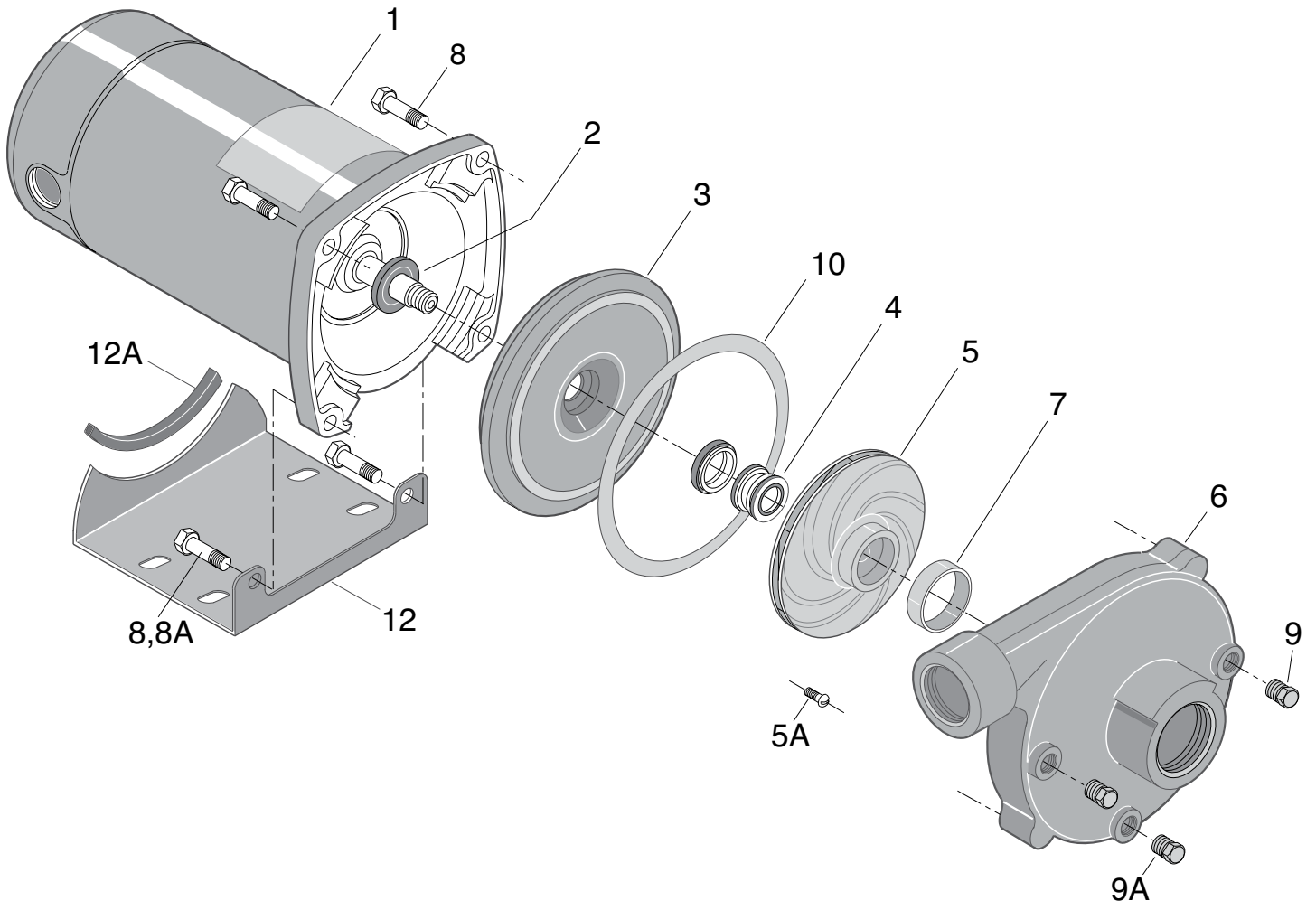

801 0394

# REPAIR PARTS LIST – “J” SERIES - HIGH HEAD

Key No.	Part Description	No. Used	MOTOR AND HORSEPOWER							
			JHB-61HL - 1/3 HP	JHC-61HL JHC3-61H 1/2 HP	JHD-62HL JHD3-62H 3/4 HP	JHE-63HL JHE3-63H 1 HP	JHF-51HL JHF3-51H 1-1/2 HP	JHG-52HL JHG3-52H 2 HP	JHHG-53HL JHHG3-53H 2-1/2 HP	
1*	Motor, 115/230V, Single Phase	1	J218-582APKG	J218-582APKG	J218-590PKG	J218-596PKG	J218-601PKG	J218-883APKG	J218-628APKG	
†2	Water Slinger	1	17351-0009	17351-0009	17351-0009	17351-0009	17351-0009	17351-0009	17351-0009	
3	Seal Plate	1	C3-1042P	C3-1042P	C3-1042P	C3-1042P	C3-1042P	C3-181	C3-181	
†4	Shaft Seal	1	U109-6A	U109-6A	U109-6A	U109-6A	U109-6A	U109-6A	U109-6A	
5	Impeller - Single Phase	1	C105-92PNX	C105-92PNX	C105-92PMX	C105-92PLX	C105-92PBX	C105-214PCA	C105-214PA	
5	Impeller - Three Phase	1	-	C105-92PNXA	C105-92PMXA	C105-92PLXA	C105-92PBXA	C105-214PCA	C105-214PA	
5A	Impeller Screw - Three Phase	1	-	C30-12	C30-14SS	C30-14SS	C30-14SS	C30-14SS	C30-47SS	
6	Volute Assembly - Complete	1	C101-284A	C101-284A	C101-284A	C101-284A	C101-284A	C101-264	C101-264B	
7	Wear Ring	(1)	C23-27	C23-27	C23-27	C23-27	C23-27	C23-19	C23-19	
8A	Capscrew - 3/8 - 16 x 1" Lg.	(2)	-	-	-	-	-	U30-74ZP	U30-99SS	
8A	Capscrew - 3/8 - 16 x 1-1/4" Lg.	(2)	U30-75ZP	U30-75ZP	U30-75ZP	U30-75ZP	U30-75ZP	-	-	
8B	Capscrew - 3/8 - 16 x 1-1/4" Lg.	(2)	U30-75ZP	U30-75ZP	U30-75ZP	U30-75ZP	U30-75ZP	U30-75ZP	U30-104ZP	
9	Pipe Plug - 1/4" NPT	(3)	U78-941ZPV	U78-941ZPV	U78-941ZPV	U78-941ZPV	U78-941ZPV	U78-941ZPV	U78-941ZPV	
†10	Gasket - Volute	1	C20-121	C20-121	C20-121	C20-121	C20-121	C20-122	C20-122	
11	Base	1	J104-9F	J104-9F	J104-9F	J104-9F	J104-9F	J104-9F	J104-9F	
11A	Motor Pad	1	C35-5	C35-5	C35-5	C35-5	C35-5	C35-5	C35-5	
<b>SERVICE KIT</b>										
	Seal and Gasket Kit	1	PP1700	PP1700	PP1700	PP1700	PP1700	PP1700	PP1700	
NOTE: † Included in Seal and Gasket Kit.										

\* For repair or service to motors, always give the motor Model Number and any other data found on the Motor Model Plate.

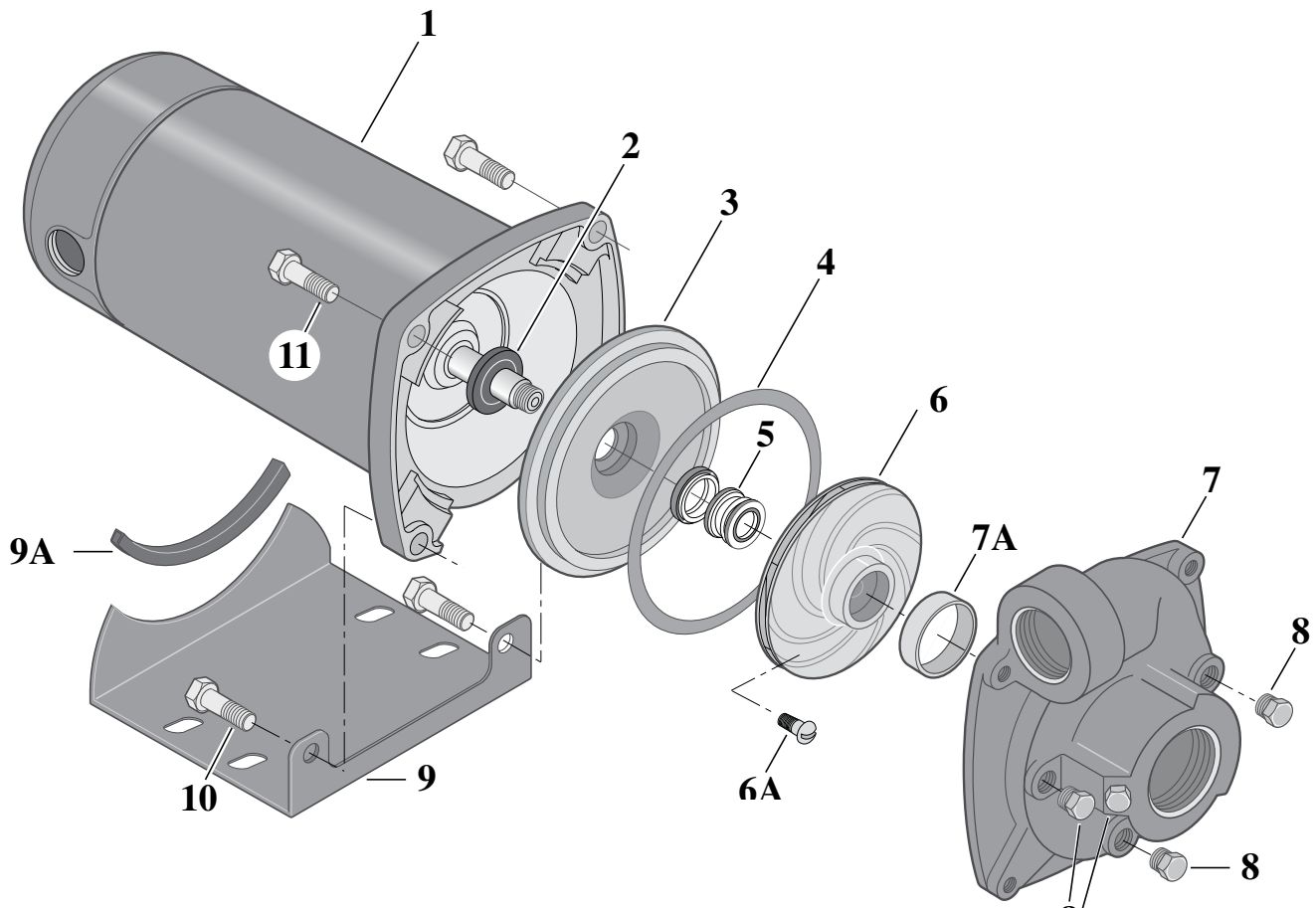

## REPAIR PARTS LIST – “J” SERIES - MEDIUM HEAD

Key No.	Part Description	No. Used	MOTOR AND HORSEPOWER			
			JMB-56L – 1/3 HP	JMC-56L JMC3-56 1/2 HP	JMD-57L JMD3-57 3/4 HP	JME-58L JME3-58 1 HP
1*	Motor, 115/230V, Single Phase	1	J218-582APKG	J218-582APKG	J218-590PKG	J218-596PKG
1*	Motor, 230/460V, Three Phase	1	–	AP100CL	AP100DL	AP100EL
†2	Water Slinger	1	17351-0009	17351-0009	17351-0009	17351-0009
3	Seal Plate	1	N3-8	N3-8	N3-8	N3-8
4	Gasket, Seal Plate	1	N29-26	N29-26	N29-26	N29-26
†5	Shaft Seal	1	U109-6A	U109-6A	U109-6A	U109-6A
6	Impeller - Single Phase	1	J105-42PHA	J105-42PHA	J105-42PJA	J105-42P
6	Impeller - Three Phase	1	–	J105-42PHA	J105-42PJA	J105-42PPA
6A	Impeller Screw - Three Phase	1	C30-21	C30-6SS	C30-6SS	C30-6SS
7	Volute Assembly w/Wear Ring	1	C101-122E	C101-122E	C101-122E	C101-122
7A	Wear Ring (Only)	(1)	N23-7	N23-7	N23-7	N23-7
8	Pipe Plug - 1/4" NPT	(4)	U78-941ZPV	U78-941ZPV	U78-941ZPV	U78-941ZPV
9	Base	1	J104-9	J104-9	J104-9	J104-9
9A	Motor Pad	1	C35-5	C35-5	C35-5	C35-5
10	Capscrews - 3/8 - 16 x 1-1/4"	(2)	U30-75ZP	U30-75ZP	U30-75ZP	U30-75ZP
11	Capscrews - 3/8 - 16 x 1-1/2"	(2)	U30-76ZP	U30-76ZP	U30-76ZP	U30-76ZP
<b>SERVICE KIT</b>						
Seal and Gasket Kit		1	PP1700	PP1700	PP1700	PP1700
NOTICE: † Included in Seal and Gasket Kit.						

\* For repair or service to motors, always give the motor Model Number and any other data found on the Motor Model Plate.



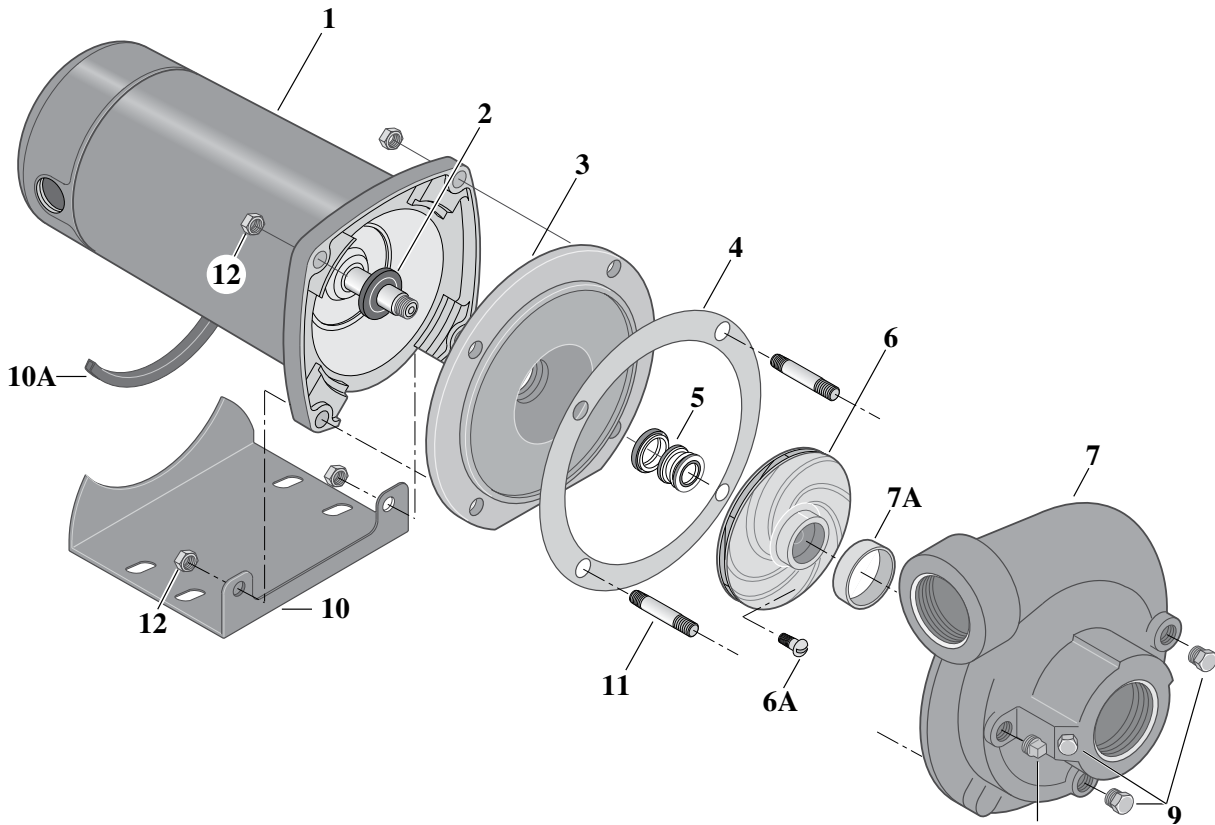

## REPAIR PARTS LIST – “J” SERIES - MEDIUM HEAD

Key No.	Part Description	No. Used	MOTOR AND HORSEPOWER	
			JMF-40L JMF3-40 1-1/2 HP	JMG-41L JMG3-41 2 HP
1	Motor, 115/230V, 1 Phase	1	J218-601PKG	J218-883APKG
1	Motor, 230/460V, 3 Phase	1	AP100FL	AP100GL
2	Water Slinger	1	17351-0009	17351-0009
3	Seal Plate	1	C3-52	C3-52
4	Gasket, Seal Plate	1	C20-21	C20-21
5	Shaft Seal	1	U109-6A	U109-6A
6	Impeller, Single Phase	1	C105-114PC	C105-114PNA
6	Impeller, Three Phase	1	C105-114PCA	C105-114PNA
6A	Impeller Screw	1	C30-14SS	C30-14SS
7	Volute Assembly with Wear Ring	1	C101-123	C101-123
7A	Wear Ring	1	C23-19	C23-19
8	Pipe Plug, 1/4" NPT Sq. Hd.	1	U78-57DT	U78-57DT
9	Pipe Plug, 1/4" NPT Hex Hd.	3	U78-941ZPV	U78-941ZPV
10	Base with Motor Pad	1	J104-9	J104-9
10A	Motor Pad	1	C35-5	C35-5
11	Stud, 3/8 - 16 x 1-13/16"	4	U30-35SS	U30-29
12	Hex Nut, 3/8 - 16	4	U36-38ZP	U36-38ZP
<b>SERVICE KIT</b>				
Seal and Gasket Kit		1	PP1700	PP1700
NOTICE: † Included in Seal and Gasket Kit.				

\* For repair or service to motors, always give the motor Model Number and any other data found on the Motor Model Plate.

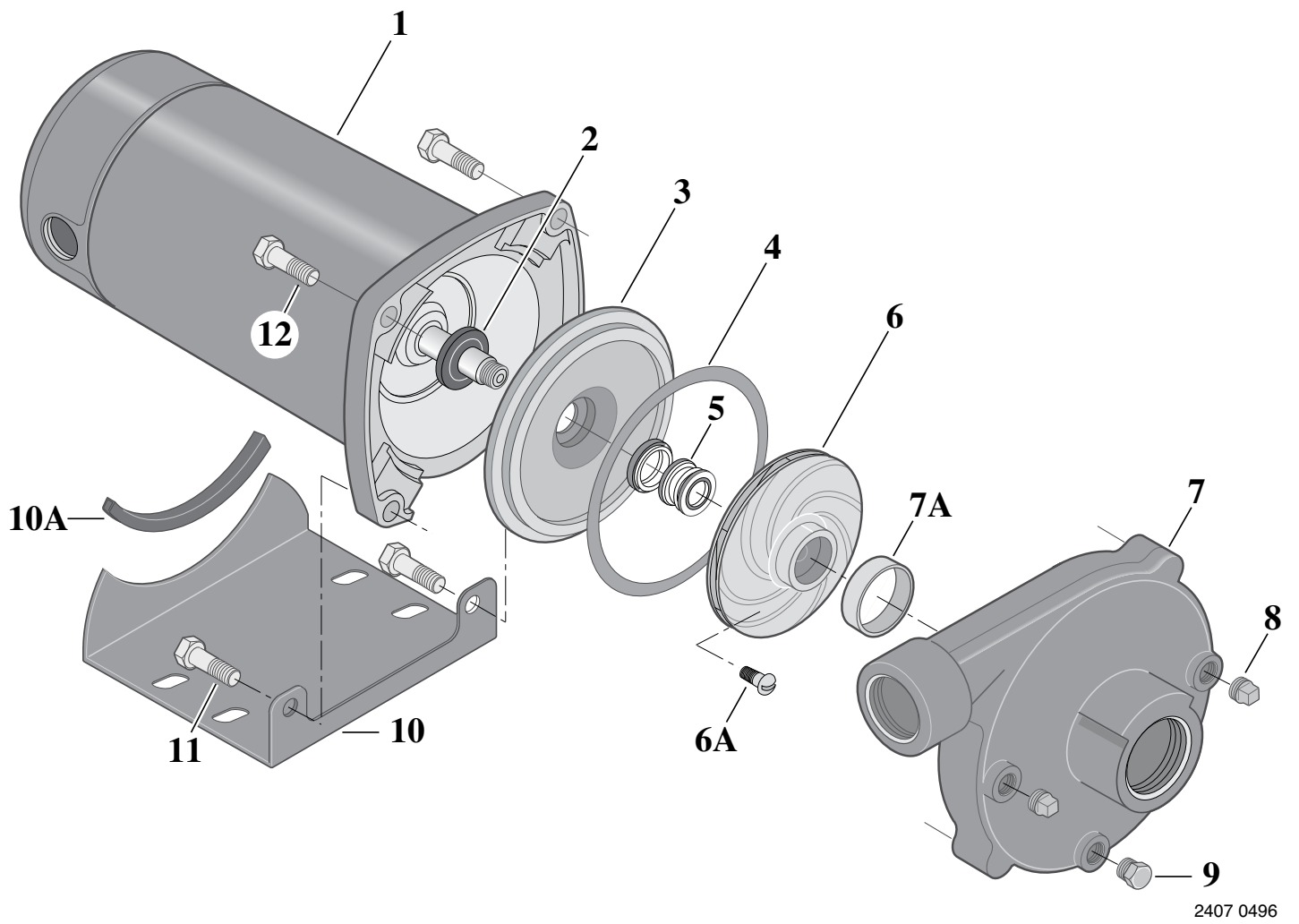

2407 0496

## REPAIR PARTS LIST – “JB” SERIES - HIGH HEAD

Key No.	Part Description	No. Used	MOTOR AND HORSEPOWER							
			JBHB-61S 1/3 HP	JBHC-61S 1/2 HP	JBHD-62S 3/4 HP	JBHE-63S 1 HP	JBHF-51S 1-1/2 HP	JBHG-52S 2HP	JBHHG-53S 2-1/2 HP	
1	Motor, 115/230V, 1 Phase	1	J218-582APKG	J218-582APKG	J218-590PKG	J218-596PKG	J218-601PKG	J218-883APKG	J218-628APKG	
1	Motor, , 230/460V, 3 Phase	1	-	AP100CL	AP100DL	AP100EL	AP100FL	AP100GL	AP100G5L	
†2	Water Slinger	1	17351-0009	17351-0009	17351-0009	17351-0009	17351-0009	17351-0009	17351-0009	
3	Seal Plate	1	C3-1042P	C3-1042P	C3-1042P	C3-1042P	C3-1042P	C3-181	C3-181	
†4	Gasket, Seal Plate	1	C20-121	C20-121	C20-121	C20-121	C20-121	C20-122	C20-122	
†5	Shaft Seal	1	U109-6A	U109-6A	U109-6A	U109-6A	U109-6A	U109-6A	U109-6A	
6	Impeller, Single Phase	1	C5-256BA	C5-256BA	C5-256BAA	C5-254BA	C5-254BC	C5-257BB	C5-257B	
6	Impeller, Three Phase	1	-	C5-256BA	C5-256BAA	C5-254BA	C5-254BC	C5-257BB	C5-257B	
6A	Impeller Screw, Three Phase	1	C30-14SS	C30-14SS	C30-14SS	C30-14SS	C30-14SS	C30-14SS	C30-14SS	
7	Volute Assembly with Wear Ring	1	C101-284A	C101-284A	C101-284A	C101-284A	C101-284A	C101-264	C101-264B	
7A	Wear Ring	1	C23-27	C23-27	C23-27	C23-27	C23-27	C23-27	C23-27	
8	Pipe Plug, 1/4" NPT Hex Hd.	3	U78-941ZPV	U78-941ZPV	U78-941ZPV	U78-941ZPV	U78-941ZPV	U78-941ZPV	U78-941ZPV	
9	Base with Motor Pad	1	J104-9	J104-9	J104-9	J104-9	J104-9	J104-9	J104-9F	
9A	Motor Pad	1	C35-5	C35-5	C35-5	C35-5	C35-5	C35-5	C35-5	
10	Hex Capscrew, 3/8" - 16 x 1" Lg.	2	-	-	-	-	-	U30-74ZP	U30-74ZP	
10	Socket Head Capscrew, 3/8" - 16 x 1" Lg. (JBHHG-53S)	2	-	-	-	-	-	-	U30-99SS	
10	Hex Capscrew, 3/8" - 16 x 1-1/4" Lg.	2	U30-75ZP	U30-75ZP	U30-75ZP	U30-75ZP	U30-75ZP	-	-	
11	Hex Capscrew, 3/8" - 16 x 1-1/4" Lg.	2	U30-75ZP	U30-75ZP	U30-75ZP	U30-75ZP	U30-75ZP	U30-75ZP	U30-75ZP	
11	Socket Head Capscrew, 3/8" - 16 x 1-1/4" Lg. (JBHHG-53S)	2	-	-	-	-	-	-	U30-104ZP	

\* For repair or service to motors, always give the motor Model Number and any other data found on the Motor Model Plate.

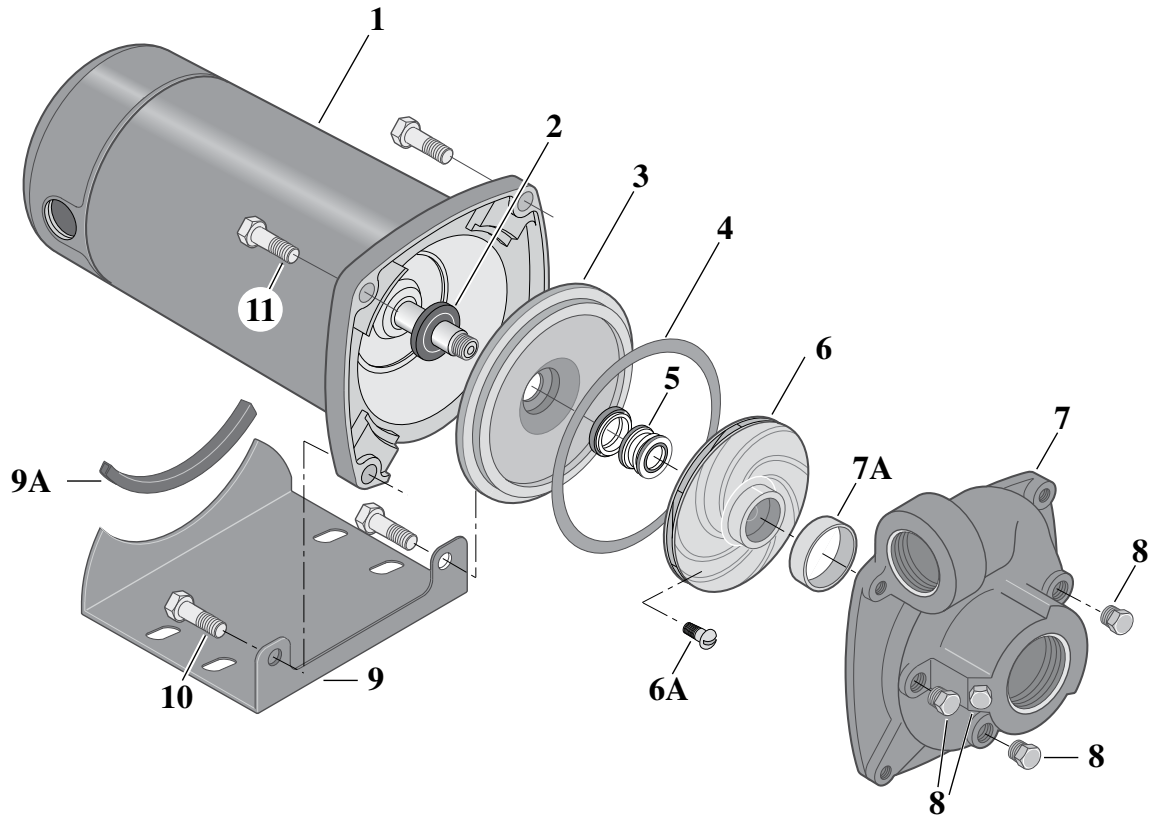

2409 0496 SPC

## REPAIR PARTS LIST – “J” SERIES - MEDIUM HEAD

Key No.	Part Description	No. Used	MOTOR AND HORSEPOWER			
			JBMB-56S – 1/3 HP	JBMC-56S JBMC3-56S 1/2 HP	JBMD-57S JBMD3-57S 3/4 HP	JBME-58S JBME3-58S 1 HP
1	Motor, 115/230V, 1 Phase	1	J218-582APKG	J218-582APKG	J218-590PKG	J218-596PKG
1	Motor, 230/460V, 3 Phase	1	–	AP100CL	AP100DL	AP100EL
2	Water Slinger	1	17351-0009	17351-0009	17351-0009	17351-0009
3	Seal Plate	1	N3-8	N3-8	N3-8	N3-8
4	Gasket, Seal Plate	1	N20-26	N20-26	N20-26	N20-26
5	Shaft Seal	1	U109-6A	U109-6A	U109-6A	U109-6A
6	Impeller, Single Phase	1	J105-42MA	J105-42MA	J105-42LA	J105-42NA
6	Impeller, Three Phase	1	–	J105-42MA	J105-42LA	J105-42NA
6A	Impeller Screw	1	–	C30-6SS	C30-6SS	C30-6SS
7	Volute Assembly with Wear Ring	1	C101-122E	C101-122E	C101-122E	C101-122
7A	Wear Ring	1	N23-7	N23-7	N23-7	N23-7
8	Pipe Plug, 1/4" NPT Hex Hd.	4	U78-941ZPV	U78-941ZPV	U78-941ZPV	U78-941ZPV
9	Base with Motor Pad	1	J104-9	J104-9	J104-9	J104-9
9A	Motor Pad	1	C35-5	C35-5	C35-5	C35-5
10	Hex Capscrew, 3/8" - 16 x 1-1/2" Lg.	2	U30-76ZP	U30-76ZP	U30-76ZP	U30-76ZP
11	Hex Capscrew, 3/8" - 16 x 1-1/4" Lg.	2	U30-75ZP	U30-75ZP	U30-75ZP	U30-75ZP
<b>SERVICE KIT</b>						
Seal and Gasket Kit		1	PP1700	PP1700	PP1700	PP1700
NOTICE: † Included in Seal and Gasket Kit.						

\* For repair or service to motors, always give the motor Model Number and any other data found on the Motor Model Plate.

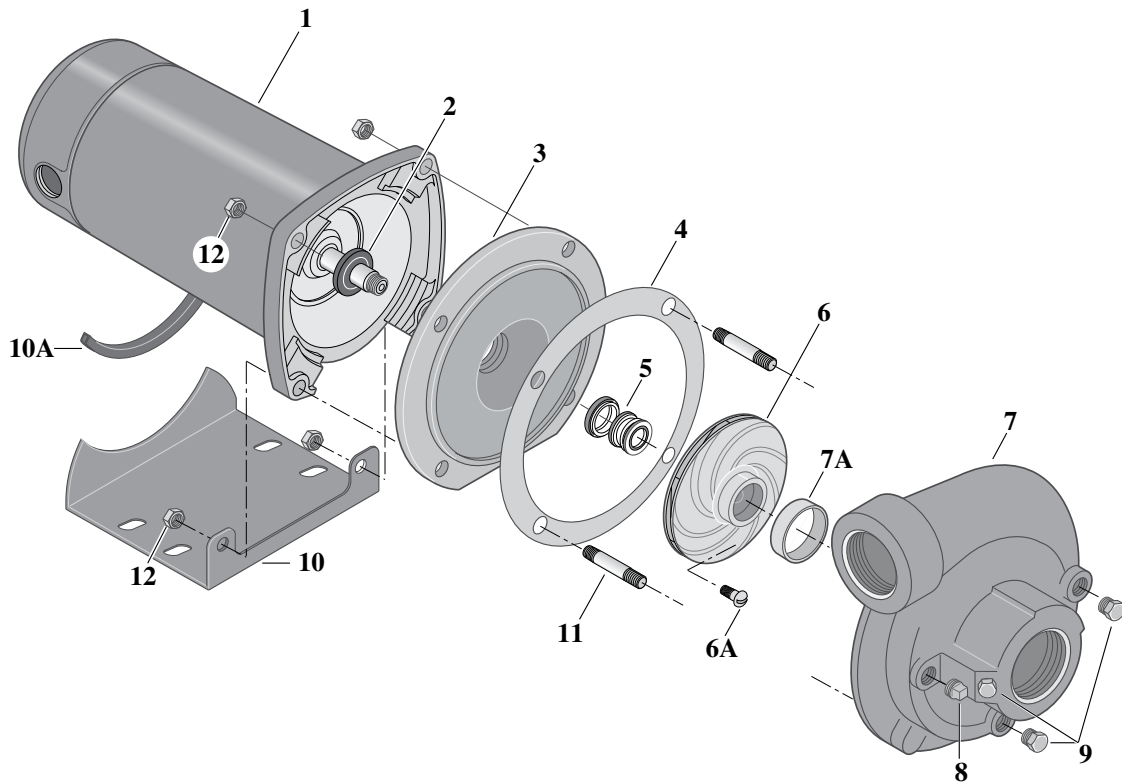

2410 0496 SPC

## REPAIR PARTS LIST – “J” SERIES - MEDIUM HEAD

Key No.	Part Description	No. Used	MOTOR AND HORSEPOWER		
			JBMF-40S JBMF3-40S 1-1/2 HP	JBMG-41S JBMG3-41S 2 HP	JBMMG-59S JBMMG3-59S 2-1/2 HP
1	Motor, 115/230V, 1 Phase	1	J218-601PKG	J218-883APKG	J218-628APKG
1	Motor, 230/460V, 3 Phase	1	AP100FL	AP100GL	AP100G5L
2	Water Slinger	1	17351-0009	17351-0009	17351-0009
3	Seal Plate	1	C3-52	C3-52	C3-52
4	Gasket, Seal Plate	1	C20-21	C20-21	C20-21
5	Shaft Seal	1	U109-6A	U109-6A	U109-6A
6	Impeller, Single Phase	1	C105-79B	C105-73BA	C105-80DA
6	Impeller, Three Phase	1	C105-79BA	C105-73BA	C105-80DA
6A	Impeller Screw	1	C30-14SS	C30-14SS	C30-14SS
7	Volute Assembly with Wear Ring	1	C101-123	C101-123	C101-123B
7A	Wear Ring	1	C23-19	C23-19	C23-19
8	Pipe Plug, 1/4" NPT Sq. Hd.	1	U78-57DT	U78-57DT	U78-57DT
9	Pipe Plug, 1/4" NPT Hex Hd.	3	U78-941ZPV	U78-941ZPV	U78-941ZPV
10	Base with Motor Pad	1	J104-9	J104-9	J104-9F
10A	Motor Pad	1	C35-5	C35-5	C35-5
11	Stud, 3/8 - 16 x 1-13/16"	4	U30-35SS	U30-35SS	U30-35SS
12	Hex Nut, 3/8 - 16	4	U36-38ZP	U36-38ZP	U36-38ZP
<b>SERVICE KIT</b>					
Seal and Gasket Kit		1	PP1700	PP1700	PP1700
NOTICE: † Included in Seal and Gasket Kit.					

\* For repair or service to motors, always give the motor Model Number and any other data found on the Motor Model Plate.

## TROUBLE - CAUSES AND REMEDY

TROUBLE AND CAUSE	REMEDY
<p><b>FAILURE TO PUMP</b></p> <p>1. Pump not properly primed.</p>	<p>1. Make sure pump casing and suction line are full of water. See priming instructions.</p>
<p><b>REDUCED CAPACITY AND/OR HEAD</b></p> <p>1. Air pockets or leaks in suction line. 2. Clogged impeller.</p>	<p>1. Check suction piping. 2. Remove and clean.</p>
<p><b>PUMP LOSES PRIME</b></p> <p>1. Air leaks in suction line. 2. Excessive suction lift and operating too near shut-off point. 3. Water level drops while pumping, uncovering suction piping.</p>	<p>1. Check suction piping 2. Move pump nearer to water level. 3. Check water supply. Add length of pipe to suction to keep submerged end under water.</p>
<p><b>MECHANICAL TROUBLES AND NOISE</b></p> <p>1. Bent shaft and/or damaged bearings. 2. Suction and/or discharge piping not properly supported and anchored.</p>	<p>1. Take motor to authorized motor repair shop. 2. See that all piping is supported to relieve strain on pump assembly.</p>

## Limited Warranty

STA-RITE warrants to the original consumer purchaser ("Purchaser" or "You") of the products listed below, that they will be free from defects in material and workmanship for the Warranty Period shown below.

Product	Warranty Period
Water Systems Products — jet pumps, small centrifugal pumps, submersible pumps and related accessories	<i>whichever occurs first:</i> 12 months from date of original installation, or 18 months from date of manufacture
Pro-Source® Composite Tanks	5 years from date of original installation
Pro-Source® Steel Pressure Tanks	5 years from date of original installation
Pro-Source® Epoxy-Lined Tanks	3 years from date of original installation
Sump/Sewage/Effluent Products	12 months from date of original installation, or 18 months from date of manufacture

Our warranty will not apply to any product that, in our sole judgement, has been subject to negligence, misapplication, improper installation, or improper maintenance. Without limiting the foregoing, operating a three phase motor with single phase power through a phase converter will void the warranty. Note also that three phase motors must be protected by three-leg, ambient compensated, extra-quick trip overload relays of the recommended size or the warranty is void.

Your only remedy, and STA-RITE's only duty, is that STA-RITE repair or replace defective products (at STA-RITE's choice). You must pay all labor and shipping charges associated with this warranty and must request warranty service through the installing dealer as soon as a problem is discovered. No request for service will be accepted if received after the Warranty Period has expired. This warranty is not transferable.

STA-RITE SHALL NOT BE LIABLE FOR ANY CONSEQUENTIAL, INCIDENTAL, OR CONTINGENT DAMAGES WHATSOEVER. THE FOREGOING WARRANTIES ARE EXCLUSIVE AND IN LIEU OF ALL OTHER EXPRESS AND IMPLIED WARRANTIES, INCLUDING BUT NOT LIMITED TO THE IMPLIED WARRANTIES OF MERCHANTABILITY AND FITNESS FOR A PARTICULAR PURPOSE. THE FOREGOING WARRANTIES SHALL NOT EXTEND BEYOND THE DURATION EXPRESSLY PROVIDED HEREIN.

Some states do not allow the exclusion or limitation of incidental or consequential damages or limitations on the duration of an implied warranty, so the above limitations or exclusions may not apply to You. This warranty gives You specific legal rights and You may also have other rights which vary from state to state.

This Limited Warranty is effective June 1, 2011 and replaces all undated warranties and warranties dated before June 1, 2011.

### **STA-RITE INDUSTRIES**

**293 Wright Street • Delavan, WI U.S.A. 53115**

**Phone: 1-888-782-7483 • Fax: 1-800-426-9446 • Web Site: sta-rite.com**

