

MYERS® ME7 Series

Cast Iron Submersible Effluent Pumps

SPECIFICATIONS

Applications	Effluent and Wastewater Removal, Sump Drainage, Dewatering, Flood Control	
Capacities	110 GPM	416 LPM
Shut-off head	58'	17.7 m
Operation:		
Tethered: On	18"	459.7 mm
Off	9"	231.1 mm
Solids handling	3/4"	19 mm
Intermittent liquid temp	130°F	54.4°C
Motor	1/2 HP, 3450 RPM, 115 Volt or 230 Volt, single-phase, 60 Hz. Oil-filled. Built-in thermal overload protection with automatic reset and permanent split capacitor.	
Acceptable pH range	6-9	
Shaft seal	Type 6A or equal, Buna-N elastomers, silicon carbide sealing faces, stainless steel metal parts	
Motor housing	Cast Iron	
Volute case	Cast iron	
Impeller	Cast iron Vortex	
Power cord	20' oil and water resistant 16-3 SJTW-A/SJTW with integrally grounded three-prong plug.	
Discharge, NPT	2"	



3 YEAR
WARRANTY



FEATURES

- Bearing and Mechanical Seal – Permanently lubricated for long life.
- Overload Protection – Built-in thermal overload with automatic reset.
- Cord Design – Prevents oil loss from and moisture protection for motor.
- Serviceability – Heavy-duty lift-out ring, field serviceable.
- Solids Handling – 3/4" spherical capability.
- Stainless Steel Hardware – Allows for easy disassembly after extended service.
- Controls – Standard controls available for automatic operation.
- Float – Mechanical (non mercury).

ORDERING INFORMATION

Catalog Number	HP	Maximum Load Amps	Volts	Phase/Cycles	Cord Length	Mechanical Switch Type	Switch Setting	
							On	Off
ME750120M	1/2	13.0	115	1/60	20'	Manual	-	-
ME750120T		13.0	115			Tethered	18.1"	9.1"
ME750220M		6.4	230			Manual	-	-

In order to provide the best products possible, specifications are subject to change.

MYERS® ME7 Series

Cast Iron Submersible Effluent Pumps

PUMP PERFORMANCE

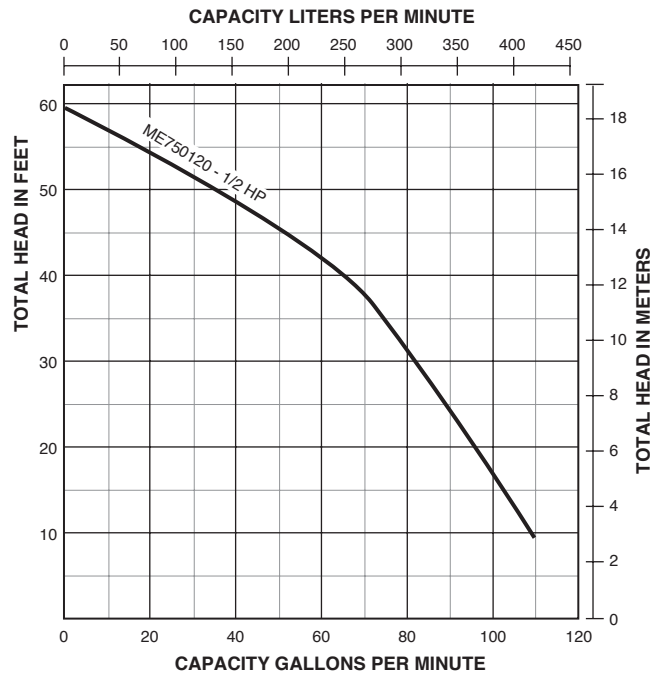

OUTLINE DIMENSIONS

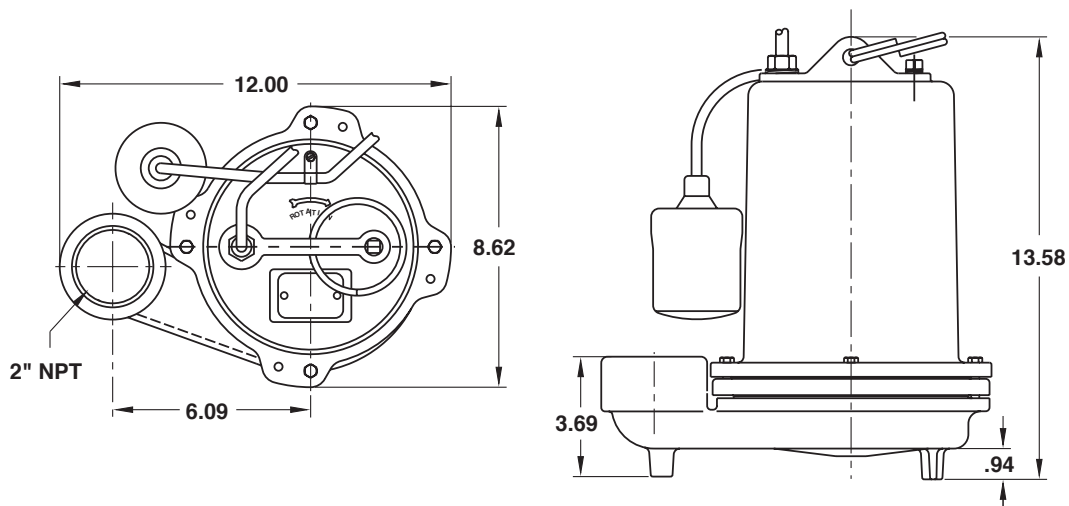

Dimensions (in inches) are for estimating purposes only.



USA
293 WRIGHT STREET, DELAVAN, WI 53115 WWW.FEMYERS.COM
PH: 888-987-8677 ORDERS FAX: 800-426-9446

CANADA
490 PINEBUSH ROAD, UNIT 4, CAMBRIDGE, ONTARIO, N1T 0A5
PH: 800-363-7867 FAX: 888-606-5484

Because we are continuously improving our products and services, Pentair reserves the right to change specifications without prior notice.