



Product information presented here reflects conditions at time of publication. Consult factory regarding discrepancies or inconsistencies.

**ENGINEERED PRODUCTS**

Zoeller Family of Water Solutions™

MAIL TO: P.O. BOX 16347 • Louisville, KY 40256-0347  
 SHIP TO: 3649 Cane Run Road • Louisville, KY 40211-1961  
 (502) 778-2731 • 1 (800) 928-PUMP • FAX (502) 774-3624

visit our web site:  
[www.zoeller.com](http://www.zoeller.com)

**DISCONNECT & RAIL SYSTEMS**  
**Threaded Discharge Pumps 1¼" thru 3" NPT**



Z-Rail® type shown

**FEATURES**

- Sewage, storm water and effluent pump systems
- For concrete, steel, or fiberglass tanks
- Allows for removal of pumps from ground level
- Coupling base with positive machine fit and o-ring seal provides a reliable seal.
- Guide rails direct the pump to and from the base discharge elbow. Systems are supplied complete with coupling base, sealing plate, pump discharge elbow, and upper rail support bracket.
- All systems use ¾" schedule 40 pipe rails (not included).
- Refer to ZM1710 for E-Z Out installation instructions and ZM2821 for Z-Rail®.

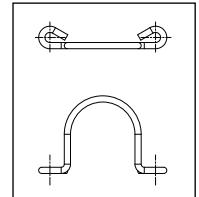

SK2486

#10-0789 lifting bails are required on 6160, 6180, 6280, 6290, 7010, and 7020/7021 models to balance pump and rail plate evenly. Other models already include proper lifting device.

SPECIFICATIONS					
Rail System	Pump Discharge	Rail System Discharge	Materials of Construction*	Weight	Type
39-0134	1-1/4" V	2" V	Powder coated, ductile iron	41	Z-Rail®
39-0135	1-1/4" V	2" V	Powder coated, ductile iron w/ SS upper rail support bracket	43	Z-Rail®
39-0136	1-1/4" V	2" V	Powder coated, ductile iron / brass for non-sparking	44	Z-Rail®
39-0143	1-1/4" V	2" V	Powder coated, ductile iron w/ SS upper rail support / brass for non-sparking	43	Z-Rail®
39-0137	1-1/4" H	1½" V	Powder coated, ductile iron (models 7020, 7021 only)	41	Z-Rail®
39-0138	1-1/4" H	1½" V	Powder coated, ductile iron w/ SS upper rail support bracket (models 7020, 7021 only)	43	Z-Rail®
39-0131	1-1/2" V	2" V	Powder coated, ductile iron	41	Z-Rail®
39-0132	1-1/2" V	1½"	Powder coated, ductile iron w/ SS upper rail support bracket	43	Z-Rail®
39-0133	1-1/2" V	2" V	Powder coated, ductile iron / brass for non-sparking	44	Z-Rail®
30-1042	1-1/2" V	2" V	Powder coated, ductile iron w/ SS upper rail support / brass for non-sparking	43	Z-Rail®
39-0128	2" V	2" V	Powder coated, ductile iron	42	Z-Rail®
39-0129	2" V	2" V	Powder coated, ductile iron w/ SS upper rail support bracket	43	Z-Rail®
39-0130	2" V	2" V	Powder coated, ductile iron / brass for non-sparking	45	Z-Rail®
39-0141	2" V	2" V	Powder coated, ductile iron w/ SS upper rail support / brass for non-sparking	44	Z-Rail®
39-0146	2" V	2" V	71 Series Grinder - Powder coated, ductile iron	43	Z-Rail®
39-0148	2" V	2" V	71 Series Grinder - Powder coated, ductile iron w/ SS upper rail support bracket	45	Z-Rail®
39-0147	2" V	2" V	71 Series Grinder - Powder coated, ductile iron / brass for non-sparking	43	Z-Rail®
39-0149	2" V	2" V	71 Series Grinder - Powder coated, D.I. w/ SS upper rail support / brass for non-sparking	44	Z-Rail®
39-0074	3" V	3" V	Cast iron / steel / galvanized steel	55	E-Z Out
39-0075	3" V	3" V	Cast iron / steel / stainless steel	55	E-Z Out
39-0076	3" V	3" V	Cast iron / brass / SS / brass for non-sparking	57	E-Z Out
ACCESSORIES - Intermediate rail brackets are required for each 12' of basin depth					
39-0139	Intermediate rail bracket 1¼", 1 ½" and 2" discharge - stainless steel			4	Z-Rail®
39-0079	Intermediate rail bracket 3" discharge - galvanized steel			6	E-Z Out
39-0080	Intermediate rail bracket 3" discharge - stainless steel			6	E-Z Out
39-0112	Intermediate rail bracket 2" x 3" discharge - galvanized steel			6	E-Z Out
39-0113	Intermediate rail bracket 2" x 3" discharge - stainless steel			6	E-Z Out
019155	2" x 3" reducer adapter for 39-0110, 39-0111 & 39-0114 rail system			5	E-Z Out
10-0789**	SS lifting bail for 6160, 6180, 6280, 6290, 7010 and 7020/7021 series			1	Both

\* Coupling base / sealing plate / upper support / bracket and rail guide.

\*\* Lifting bails are required on the following models to balance pump and rail plate evenly. Other models already include proper lifting device.

# SQUARE GUIDE RAIL SYSTEMS (1¼", 1½" & 2" Discharge) FIELD ASSEMBLED

- Economical: reduces time & cost of removing pump.
- Safety: keeps personnel out of pits & out of contact with contaminants.
- Inspections made fast & easy.

## FEATURES

- Single, rigid, stainless steel square rail design
- Stainless steel rail, nuts, bolts, fasteners and lifting bail
- Cast iron angle arm bracket and pump guide bracket
- Galvanized piping or stainless steel - optional
- Red brass disconnect fittings with Teflon®-coated Buna O-ring seal
- PVC ball valve
- Cast iron check valve
- Optional stainless steel pull rods and lifting cable available
- Also available in prepackaged fiberglass basins

\* For tanks deeper than 72" a second angle arm bracket P/N 39-0070 is required. Sch. 40 galvanized or stainless steel pipe is used for extending the rail length.

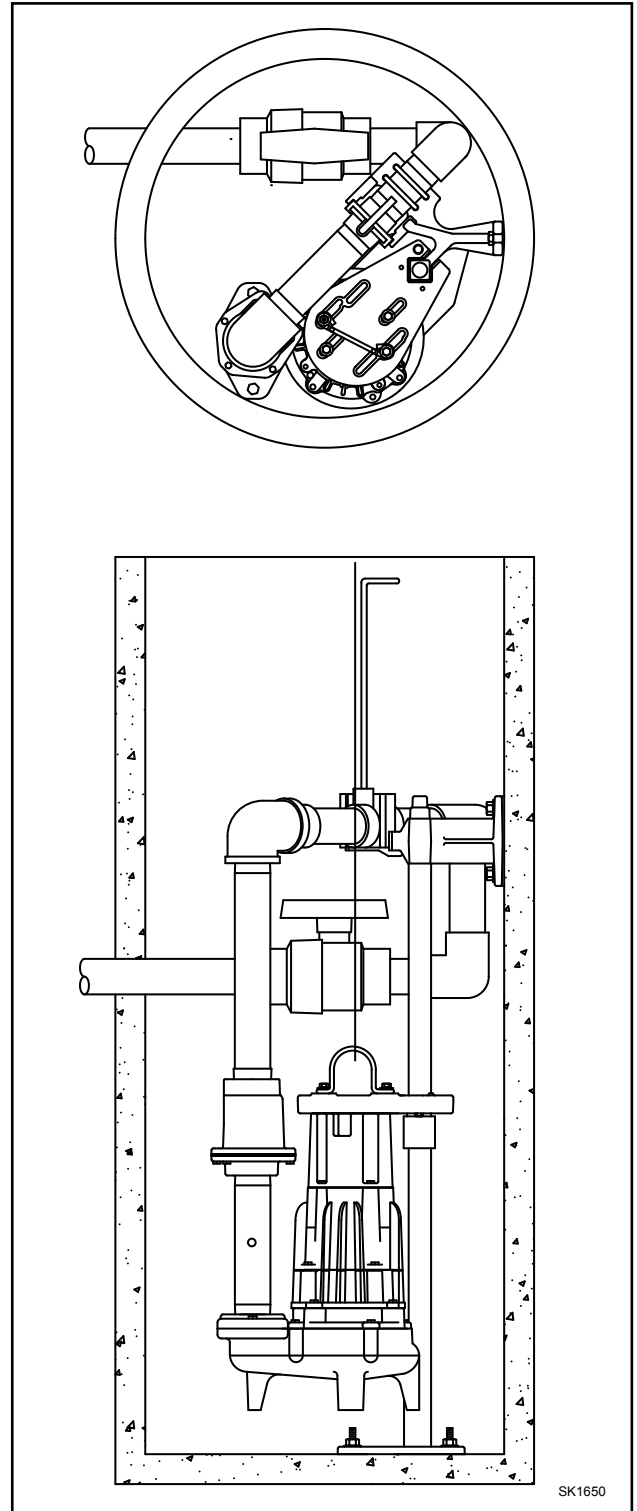

Rail System	*Tank Depth	Discharge Pipe size	Pump Series
39-0054	48"	1 ¼"	7011 grinders
39-0055	60"	1 ¼"	7011 grinders
39-0056	72"	1 ¼"	7011 grinders
39-0057	48"	1 ¼"	7010 grinders
39-0058	60"	1 ¼"	7010 grinders
39-0059	72"	1 ¼"	7010 grinders
39-0060	48"	1 ½"	6160 - 6180 effluent pumps
39-0061	60"	1 ½"	6160 - 6180 effluent pumps
39-0062	72"	1 ½"	6160 - 6180 effluent pumps
39-0063	48"	2"	6160 - 6180 - 6290 effluent & sewage pumps
39-0064	60"	2"	6160 - 6180 - 6290 effluent & sewage pumps
39-0065	72"	2"	6160 - 6180 - 6290 effluent & sewage pumps
39-0066	48"	2"	6280 sewage pumps
39-0067	60"	2"	6280 sewage pumps
39-0068	72"	2"	6280 sewage pumps

## Stainless Steel Pull Rods

3/8"-16 UNC	
Part Number	Length
39-0069	1'
39-0006	2½'
39-0007	3½'
39-0008	4½'
39-0009	5½'

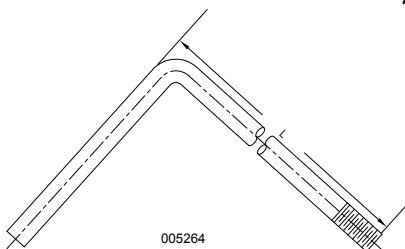

## 1/8" Stainless Steel Lifting Cables\*

Part Number	Length
39-0031	8'
39-0032	12'
39-0033	16'
39-0034	20'
39-0035	24'

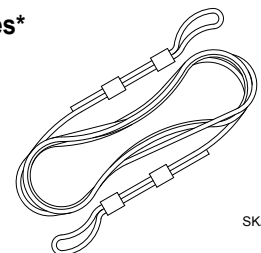

\* Cable recommended for commercial duty pumps and 2HP Grinder Pumps.

# FLANGED RAIL SYSTEMS (2½" TO 6" Discharge) FIELD ASSEMBLED

Guide rail system for removal and installation of flanged, horizontal discharge pumps without getting in or removing fluid from pit.

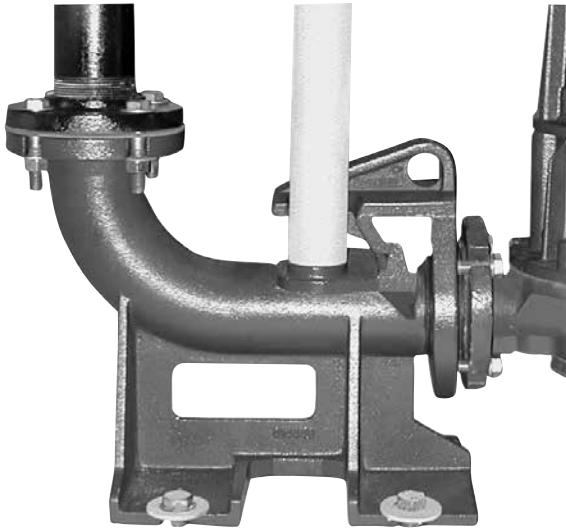

**2½" & 3" Horizontal Flanged**

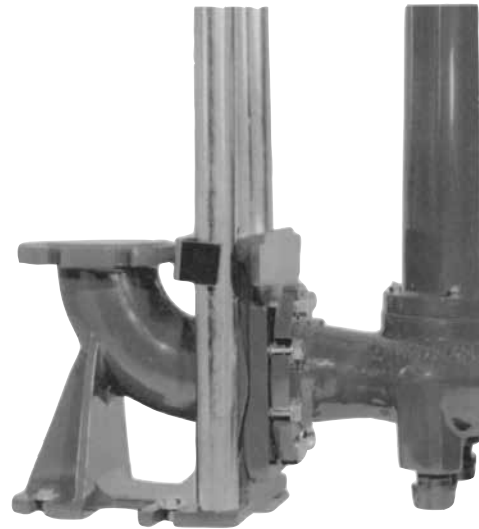

**4" & 6" Systems**

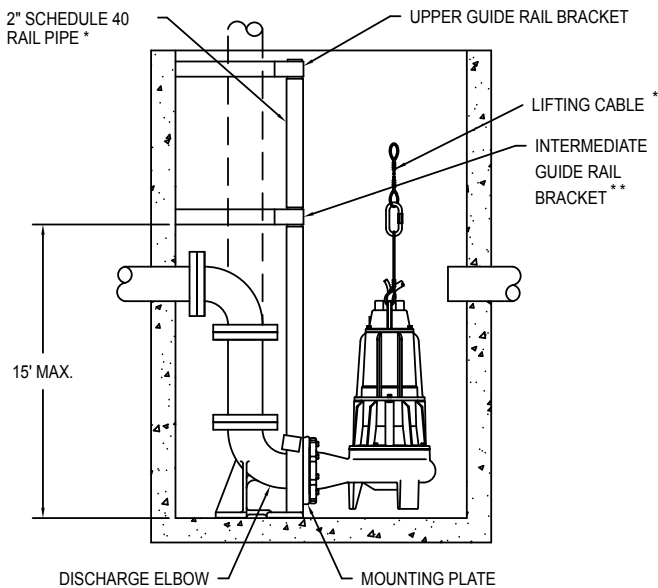

ZEPA0304

\* 1/4" lifting cable not included. See ZM1328 for correct cable.

\*\* One intermediate guide rail bracket is required for every 20 ft. for 3" system or 15 ft. for 4" system, of basin depth. See chart for part number.

SPECIFICATIONS			
Part Number	Description	Pump Discharge	Guide Rails*
39-0094	2½" / 3" guide rail system SS	2½" or 3" horizontal flange	2" SS or galv.
6039-0016	4" guide rail system SS flange	4" horizontal	2" SS or galv.
6039-0072	6" guide rail system SS flange	6" horizontal	2" SS or galv.
39-0095	2½" / 3" guide rail system SS non-sparking for Class I Group C and/or Group D Division 1 installation	2½" or 3" horizontal flange	2" SS or galv.
6039-0017	4" guide rail system, non-sparking for Class I Group C and/or Group D Division 1 installation	4" horizontal flange	2" SS or galv.
6039-0073	6" guide rail system, non-sparking for Class I Group C and/or Group D Division 1 installation	6" horizontal flange	2" SS or galv.
39-0096	Intermediate bracket for 2½" / 3" rail systems		
6039-0014	Intermediate bracket for 4" rail systems		
6039-0021	Intermediate bracket for 6" rail systems		

## 3", 4" & 6" FLYGT GUIDE RAIL SYSTEM ADAPTERS

Adapter plates for retrofitting 3", 4" & 6" horizontal discharge pumps to existing Flygt rail systems.

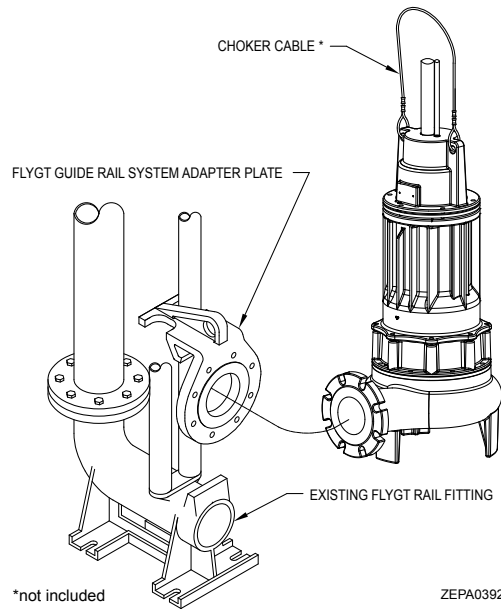

### DESIGN FEATURES

- Cast iron construction
- Flange conforms to ANSI B16.10 fully flat/MSS SP-6.
- For use with all 6400, 61 HD and 62 HD series pumps with 3", 4" or 6" discharges and 2" NPT rail pipe.
- Flange gasket and stainless steel bolts included.

Pump Discharge	Part Number
3"	6039-0070
4"	6039-0048
6"	6039-0053

## DISCONNECT ONLY (1 1/4", 1 1/2" & 2" Discharge)

Disconnect fitting; used for shallow systems where guide rails are not necessary. (pull rod not included)

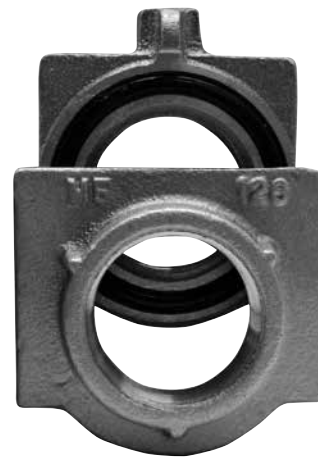
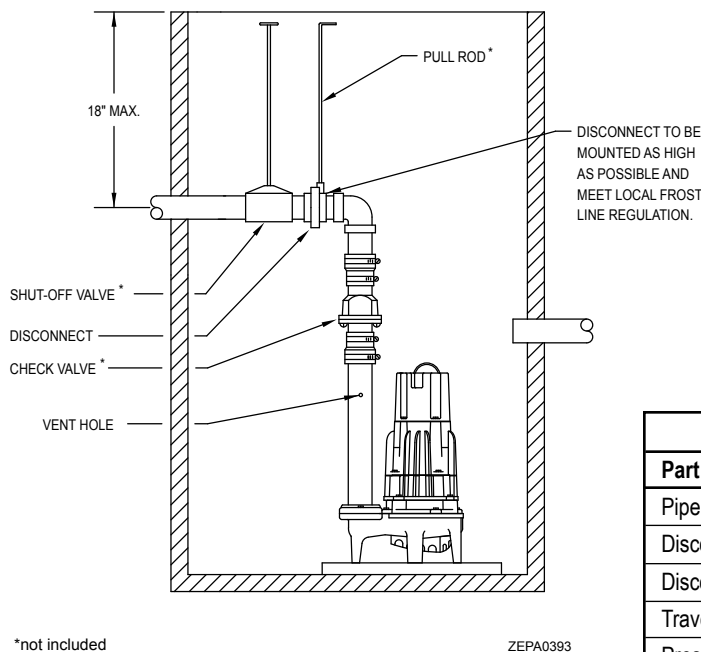

39-0053, 1 1/4" NPT  
39-0001, 1 1/2" NPT  
39-0002, 2" NPT

### SPECIFICATIONS

Part Number	39-0053	39-0001	39-0002
Pipe size	1 1/4"	1 1/2" NPT	2" NPT
Disconnect material	brass	brass	brass
Disconnect weight	1.6 lb.	2.0 lbs.	2.5 lbs.
Travel to disengage	3 3/4"	3"	3 1/2"
Pressure rating	150 PSI	150 PSI	150 PSI
Pull rods thread size	3/8" - 16 UNC	3/8" - 16 UNC	3/8" - 16 UNC

NOTE: All pumps should be supported underneath with concrete blocks or basin floor.