



Product information presented here reflects conditions at time of publication. Consult factory regarding discrepancies or inconsistencies.

Register your
Zoeller Pump Company
Product on our website:
<http://reg.zoellerpumps.com/>

PUMP COMPANY

Zoeller Family of Water Solutions™

MAIL TO: P.O. BOX 16347 • Louisville, KY 40256-0347
SHIP TO: 3649 Cane Run Road • Louisville, KY 40211-1961
(502) 778-2731 • 1 (800) 928-PUMP • FAX (502) 774-3624

visit our web site:
www.zoeller.com

Patent No. D740329



**12 VOLT DC BATTERY BACKUP PUMP
INSTALLATION INSTRUCTIONS**

P/N 152520

PREINSTALLATION CHECKLIST

1. Inspect your pump. Occasionally, products are damaged during shipment. If the unit or any of the parts are damaged, contact your dealer before using.
2. Read all the installation instructions regarding installing and start up. Retain for future reference.



WARNING

SEE BELOW FOR LIST OF WARNINGS

1. Testing for Ground. As a safety measure each electrical outlet should be checked for ground using an Underwriters Laboratory listed circuit analyzer, which will indicate if the power, neutral and ground wires are correctly connected to your outlet. If they are not, call a qualified, licensed electrician.
2. For your protection always disconnect the power supply from its power source before handling the components of your DC backup pump or the primary pump.
3. Installation and checking of electrical circuits and hardware should be performed by a qualified, licensed electrician.
4. All electrical and safety codes must be followed in addition to the National Electrical Code and all applicable local codes.
5.  It is the owner's responsibility to check the battery and battery connection at least once a month. Batteries contain acid and caution must be taken when handling.
6. Risk of electric shock - These pumps have not been investigated for use in swimming pool areas.
7. According to the state of California (Prop 65), this product contains chemicals known to the state of California to cause cancer and birth defects or other reproductive harm.

CAUTION

SEE BELOW FOR LIST OF CAUTIONS

1. Make sure there is a properly grounded 115V/230V receptacle available. Do not use primary pump circuit. The location must be within 6' of the control box and battery. The power supply for your DC control system plugs directly into the 115V/230V outlet. **DO NOT USE AN EXTENSION CORD.**
2. Make sure the 115V/230V electrical supply circuit is equipped with fuses or circuit breakers of proper capacity.
3. DC emergency pumps are designed for handling clear water. Do not use in septic tanks to pump effluent or sewage pits to pump sewage.
4. Repair and service of your DC backup system should be performed by an authorized service station.
5. The installation of DC automatic backup pumps requires the use of a variable level float switch for operation. It is the responsibility of the installing party, to ensure that the float switch will not hang up on the pump apparatus or pit peculiarities and is secured so the pump will turn "on" and "off". It is recommended that the pit be 18" (457 mm) in diameter or larger to accommodate both a primary and a DC backup pump.
6. For indoor use only.
7. Installation and maintenance of this appliance is not intended for persons (including children) with reduced physical, sensory or mental capabilities, or lack of experience or knowledge, unless they have been given supervision or instruction concerning use of the appliance by a person responsible for their safety.

CAUTION Turbulence caused by high velocity incoming water can cause sump pumps to airock. If this condition exists, the incoming water must be baffled to avoid excessive turbulence.

REFER TO WARRANTY ON PAGE 2.

LIMITED WARRANTY

Manufacturer warrants, to the purchaser and subsequent owner during the warranty period, every new product to be free from defects in material and workmanship under normal use and service, when properly used and maintained, for a period of 3 years from date of purchase by the end user. Parts that fail within the warranty period, that inspections determine to be defective in material or workmanship, will be repaired, replaced or remanufactured at Manufacturer's option, provided however, that by so doing we will not be obligated to replace an entire assembly, the entire mechanism or the complete unit. No allowance will be made for shipping charges, damages, labor or other charges that may occur due to product failure, repair or replacement.

This warranty does not apply to and there shall be no warranty for any material or product that has been disassembled without prior approval of Manufacturer, subjected to misuse, misapplication, neglect, alteration, accident or uncontrollable act of nature; that has not been installed, operated or maintained in accordance with Manufacturer's installation instructions; that has been exposed to outside substances including but not limited to the following: sand, gravel, cement, mud, tar, hydrocarbons, hydrocarbon derivatives (oil, gasoline, solvents, etc.), or other abrasive or corrosive substances, wash towels or feminine sanitary products, etc. in all pumping applications. The warranty

set out in the paragraph above is in lieu of all other warranties expressed or implied; and we do not authorize any representative or other person to assume for us any other liability in connection with our products.

Contact Manufacturer at, 3649 Cane Run Road, Louisville, Kentucky 40211, USA. Attention: Customer Support Department to obtain any needed repair or replacement of part(s) or additional information pertaining to our warranty.

MANUFACTURER EXPRESSLY DISCLAIMS LIABILITY FOR SPECIAL, CONSEQUENTIAL OR INCIDENTAL DAMAGES OR BREACH OF EXPRESSED OR IMPLIED WARRANTY; AND ANY IMPLIED WARRANTY OF FITNESS FOR A PARTICULAR PURPOSE AND OF MERCHANTABILITY SHALL BE LIMITED TO THE DURATION OF THE EXPRESSED WARRANTY.

Some states do not allow limitations on the duration of an implied warranty, so the above limitation may not apply to you. Some states do not allow the exclusion or limitation of incidental or consequential damages, so the above limitation or exclusion may not apply to you.

This warranty gives you specific legal rights and you may also have other rights which vary from state to state.

In those instances where damages are incurred as a result of an alleged pump failure, the Homeowner must retain possession of the pump for investigation purposes.

MAINTENANCE

- Inspect and test the system for proper operations at least every 3 months.
 - Red power on indicator light should be "on" indicating AC power is on.
 - Unplug primary pump and the control charger from power supply.
 - Fill sump with water to the "on" level for the DC pump. Allow pump to run a few minutes.
 - The alarm will sound approximately 5 seconds after the pump starts to run.
 - Push alarm reset switch. The alarm will go "off".
 - Pump will shut off after water level is lowered and the float drops to the off position.
- Plug the control charger and the primary pump into the wall outlet.
 - The primary pump will come on and lower the water to the normal operating level and shut off.
 - The "yellow" charging light should be on. The charger is replacing the energy consumed during the test. The "green" light will come on after the charger has replaced the energy consumed during the test.
- Add distilled water to battery when necessary per battery manufacturer's instructions. **▲ CAUTION** Battery acid is dangerous. Take proper safety precautions. Do not splash the acid.

TROUBLESHOOTING INFORMATION

- Charging and charged LED's alternate frequently.
 - This is normal.
- DC Pump won't run.
 - Check 15 amp fuse in line from pump to switch (see fig. 4). If fuse is blown, replace with 15 amp Littelfuse type 3AG, series 311.
 - Check for proper connections.
 - Check all wire terminal points. Clean if required.
 - Check for low battery. Service battery if required.
- Pump runs but pumps very little or no water.
 - Check for low battery. Battery will recharge if Red power "on" light indicates power has been restored and the float switch is in the off position.
 - If immediate usage is required, remove and replace dead battery with a full recharged battery.
 - Due to varying conditions the pump may continue to run on a low battery without sufficient power to remove water. Pump will not stop running until battery is completely discharged.
 - ▲ CAUTION** Weak batteries can be recharged but may not store sufficient energy for full service. A weak recharged battery can only be detected by reduced pumping time or by checking each cell with a hydrometer. If your emergency pump system is used frequently the battery should be checked by a qualified battery dealer.
- Pump cycles too frequently.
 - Check positions of rubber stops on float rod.
 - Adjust upper rubber float stop as required. Recommended for standard installation.
- Float switch in "on" position. Pump won't run.
 - Remove pump. Check for obstruction in pump preventing impeller from rotating.
- Pump runs, but pumps water intermittently.
 - Pump is air locking. Check flow of water incoming to sump. If water is entering the sump at a high velocity creating a turbulent condition, a mixture of air and water may cause a complete or partial air lock and reduce or stop the flow of water in the discharge pipe.
 - Baffle the incoming stream of water to reduce turbulence. Diverting water stream against wall of basin usually corrects an air lock problem.
- Water level stays high. DC Pump continues to run.
 - Battery is low.
 - If power has been restored and water in sump remains high check primary pump. Service if required.
 - After several hours the battery will be restored to full charge.
- Alarm sounds during battery recharge cycle.
 - Push alarm reset (max. 3 times). If condition persists, replace battery.
 - To silence alarm if alarm will not reset, unplug the charger from 115V wall outlet, then disconnect the black lead from charger on negative (-) battery post. Check battery. Replace if necessary. Reconnect and refer to Installation (step 7).
- Alarm does not sound when pump runs.
 - Pumps needs to run for 1 or more seconds before alarm sounds.
 - Be sure alarm hasn't been silenced. Quickly press and release reset button.
 - Inspect the connection between the green wire and the blue connector on the white wire. Verify that the metal spade has not "missed" its target.

DESCRIPTION

The DC emergency pump is designed as a backup to your primary sump pump during unexpected power outages or primary pump failure. The DC pump, electronic controls and all the parts required for installation are included except the battery which is supplied by the user. The system is designed for installation in sumps with minimum of 18" (457 mm) diameter and 22" (559 mm) deep.

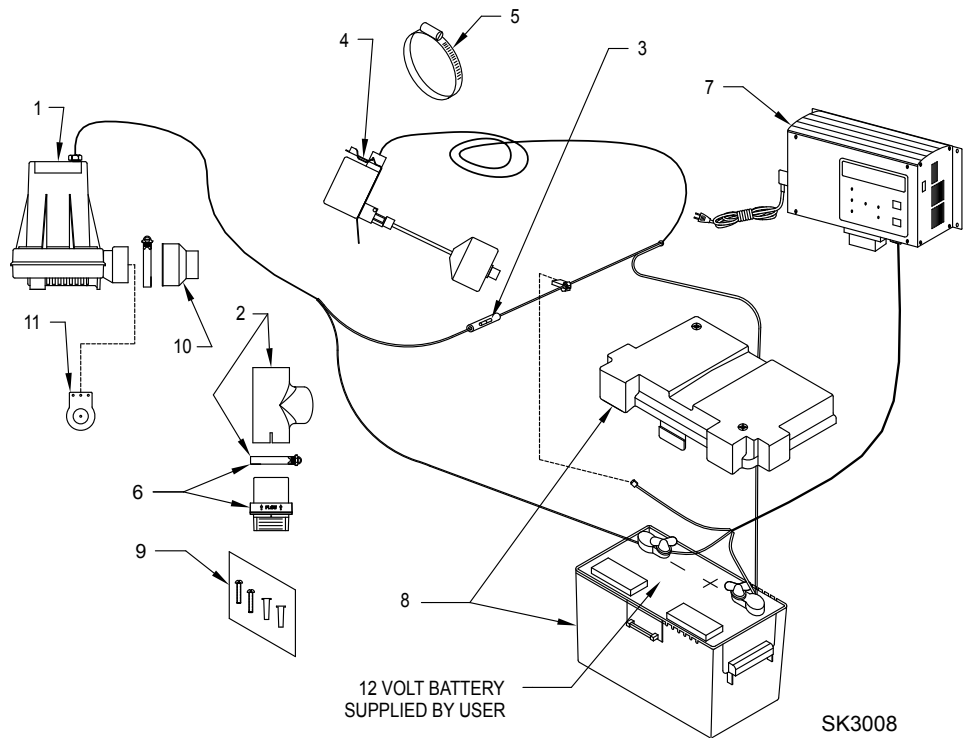

SK3008

Model 508				
Item	Description	Qty	508-A 01/14 thru 06/15	508-B 07/15 thru Current
1	Pump 12V DC / Backup (Service Part)	1	152962	152962
2	Fitting, PVC 1.5" (DN40) Tee / Sch 40 / (Pressure Fitting)	1	005645	153766
3	Fuse, 250V / Agc-30	1	012353	012353
4	Switch, Float / Vert Master	1	017197	017197
5	Clamp, #28 Worm-SS (Float Switch)	1	012724	012724
6	Valve, Check / 1.5" (DN40) Inline / Vertical	1	019768	153772
7	Charger, DC Asm / Switch Mode	1	153000	153000
8	Battery Box Asm (Box and Cover)	1	10-0764	10-0764
9	Hardware Pak, Charger / Switch Mode	1	152864	152864
10	Fitting, Asm & Clamp "508" (Service part)	1	152969	152969
11	Flapper Asm, (Service part)	1	152970	152970

PERFORMANCE

The DC pump performance with fully charged 12V battery

Discharge	5 ft (1.5 m)	10 ft (3 m)	15 ft (4.6 m)	20 ft (6 m)	22 ft (6.7 m)
Flow GPM (LPM)	39 (148)	30 (114)	20 (76)	6 (23)	Shut-off Head

The DC controller is equipped with a 10 amp charger for maintaining the battery in a ready state and recharging the battery after use when AC power is restored. Time for recharge depends upon the amount of power consumed by the pumping cycle during the AC power interruption. The pump may go back to the ready run position in a very short period of time. A completely drained battery may require up to 24 hours for full recharge. If battery does not charge properly, the LCD will display BATFAIL and alarm will sound.

BATTERY SELECTION

The DC emergency pump system requires a good quality, 12 volt battery to obtain maximum pumping time during a power outage. A deep-cycle, 12 volt, 105 amp-hour marine battery or larger is recommended and will provide approximately 6 hours of continuous pumping time in a sump pump installation with 8' (2.4 m) of head pressure. In most installations the pump runs intermittently and the battery life is extended accordingly. Batteries with top terminals are recommended for ease of installation. "Wet" cell batteries contain acid and proper precaution must be taken when handling. Battery box will accommodate a maximum battery size of 13½" (342 mm) Length x 7" (178 mm) Width x 9½" (241 mm) Height.

INSTALLATION

1. The preferred method of installation for backup pumps is shown in Figures 1 and 2. The installation kit includes the necessary fittings and one check valve for installing with the backup pump discharging into the primary pump outlet pipe. An additional check valve is incorporated in the discharge of the backup pump.

NOTE: Do not install in small spaces where the charger will not be properly cooled.

2. Remove all parts from shipping carton and make sure all parts are included. Refer to checklist on page 3.
3. Select location for battery and control charger. Control charger must be within 6' (1.8 m) of a 115V/230V wall outlet and within 6' (1.8 m) of pump and basin. Connect to a separate circuit, different than the primary pump.
4. If primary pump is installed, disconnect power.

NOTE: Discharge piping must be 1-1/2" (DN40) SCH 40 PVC

5. Remove the discharge pipe from the pump and put to the side.
6. Solvent weld DC discharge reducer fitting to tee as shown in Figure 4. Then ensure o-ring is properly located on pump discharge. Slide DC pump into the fitting and tighten the hose clamp. Position the clamp's gear drive so that it will not interfere with the operation of the switch.

NOTE: The pump must be pushed all the way into the fitting to prevent the fitting from leaking.

7. Install in-line check valve into primary pump discharge.
8. Determine the position of the DC pump and connect the pipe tee to the in-line check valve and tighten hose clamp. See Figure 4.

NOTE: Check float operations to ensure the hose clamp screws do not interfere with the float operation of the primary pump.

9. Assemble the float assembly per figure 5.
10. Install the float switch assembly bracket above the outlet tee using the clamp provided (see figures 1 and 2). Make certain the clamp is tight on the pipe to avoid slippage. Ensure that the "off" level of the float is 1" (25.4 mm) min. above the discharge tee of the DC backup pump (see figures 1 and 2). Position pumps in the sump and move float up and down, making sure of free movement without interference from any obstructions inside the sump or lid. The float switch can be moved on the discharge pipe or the rubber stops can be adjusted as necessary. Cut extra float rod length below lower float stop to prevent debris from interfering with float operation.
11. Mount DC charger to the wall. If more convenient, the charger may be set on a nearby shelf or ledge. The charger should be located 3' (0.9 m) or 4' (1.2 m) above the sump. Then, remove protective screen from the front of

the charger.

12. Connect the leads from the control charger to the battery terminals. Positive (+) lead to positive terminal and black neg. (-) lead to negative battery terminal. Upon proper connection, test alarm will momentarily sound. This indicates proper charger to battery connection.
▲ CAUTION Correct battery hook up is essential for operation of the system. Use wing nuts supplied with battery and eyelet connectors on battery wire leads. The positive terminal is the larger stud, 3/8" (10 mm) diameter. The smaller stud, 5/16" (78 mm) diameter is the negative terminal. Apply grease to the terminals to help prevent corrosion.
13. Connect the black lead from the pump to the negative (-) battery terminal. Connect the white lead from the pump to the black lead from the switch. This connection is made at the fuse installed on the switch wire (see figure 3). Connect the white lead from the switch to the positive (+) battery terminal.
14. Connect the green sensor wire to the sensor connector (figure 3).
15. Close battery box and secure cover.
16. Plug the charger's cord into charger and the 115V/230V wall outlet. The primary sump pump and the control box should be on separate circuits.
17. Reconnect power to primary sump pump.
18. Optional: A dongle may be used to input a name and number into the charger for service information to the end user.
19. Optional: On the bottom of the charger there is a pair of dry contacts to signal an auxiliary device of a low battery, high water and reverse polarity alarm condition. This simple 2-wire connection is rated at a maximum of 24V AC/DC and 0.5 amps. It can be used with an auto-dialer, alarm or home security system. Read the auxiliary equipment's documents for further instructions.

INITIAL START-UP AND OPERATION

1. Test the installation for leaks by running water into the sump allowing for normal operation of the primary pump.
2. Check the control charger. The "red" power on light will be lit when the unit is plugged into the 115V/230V wall outlet. The "charged/charging" light will indicate the condition of the battery when charger has AC power.
3. Disconnect primary pump before touching any component in the sump pit.
4. Lift float switch. The DC backup pump will run and the alarm will sound in about 1 or more seconds. Lower float switch immediately after alarm sounds. Pump runs dry during initial check for several seconds.
▲ CAUTION Continuous dry running may cause overheating and damage the pump seals. Upon release of the float switch, the pump will shut off. Press the reset button to turn the alarm off.
5. Complete the final testing of your installation by ensuring the primary pump is still disconnected from the power. Then, unplug the charger from the

115V/230V wall outlet. Run water into the sump until the DC backup pump is activated by the float switch. Check all connections for leaks.

NOTE: When running the primary pump, it is normal for a stream of water to spray out of the 1/8" (3 mm) air relief hole.

6. Push alarm reset switch when pump is running. This will silence the alarm. The pump will continue to run.
7. Reconnect the charger and your primary pump to the AC wall outlets. The primary pump should come on and lower the water level in the sump back to the normal operating level and shut off. Use the alarm reset button to reset the high water light. Both primary and backup systems are now ready for use.
8. The battery charged and charging LED's will alternate during normal charging operation.

NOTE: See page 7 for a description of charger functions.

ASSEMBLY WITH SUBMERSIBLE PUMP

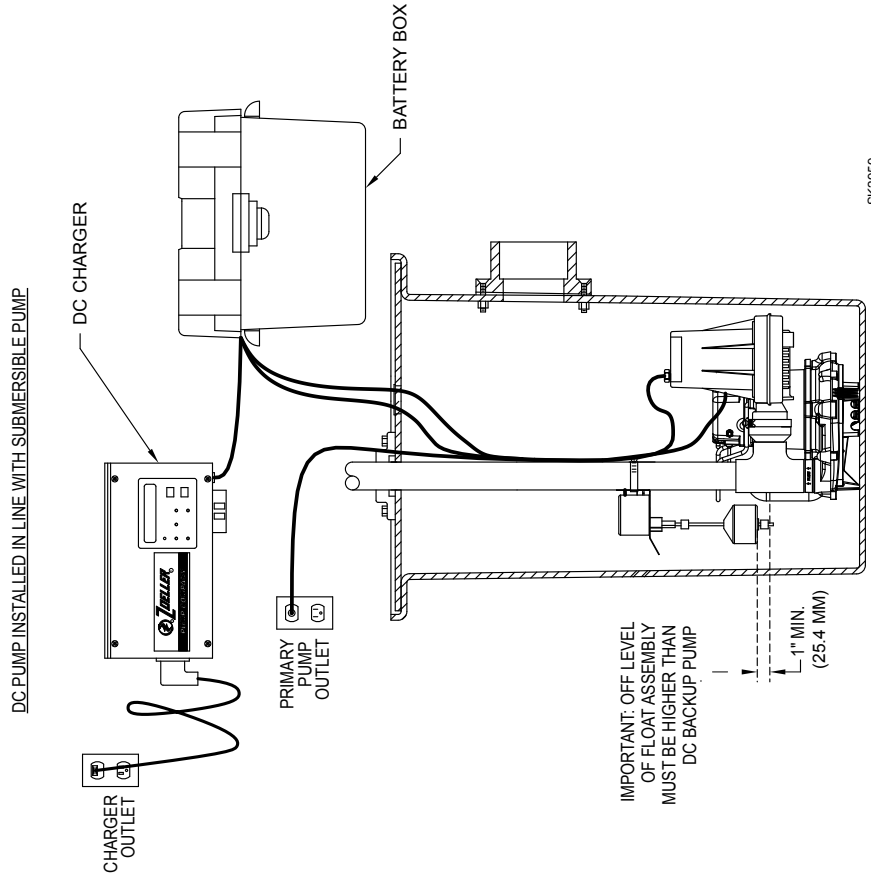

FIGURE 1

ASSEMBLY WITH COLUMN PUMP

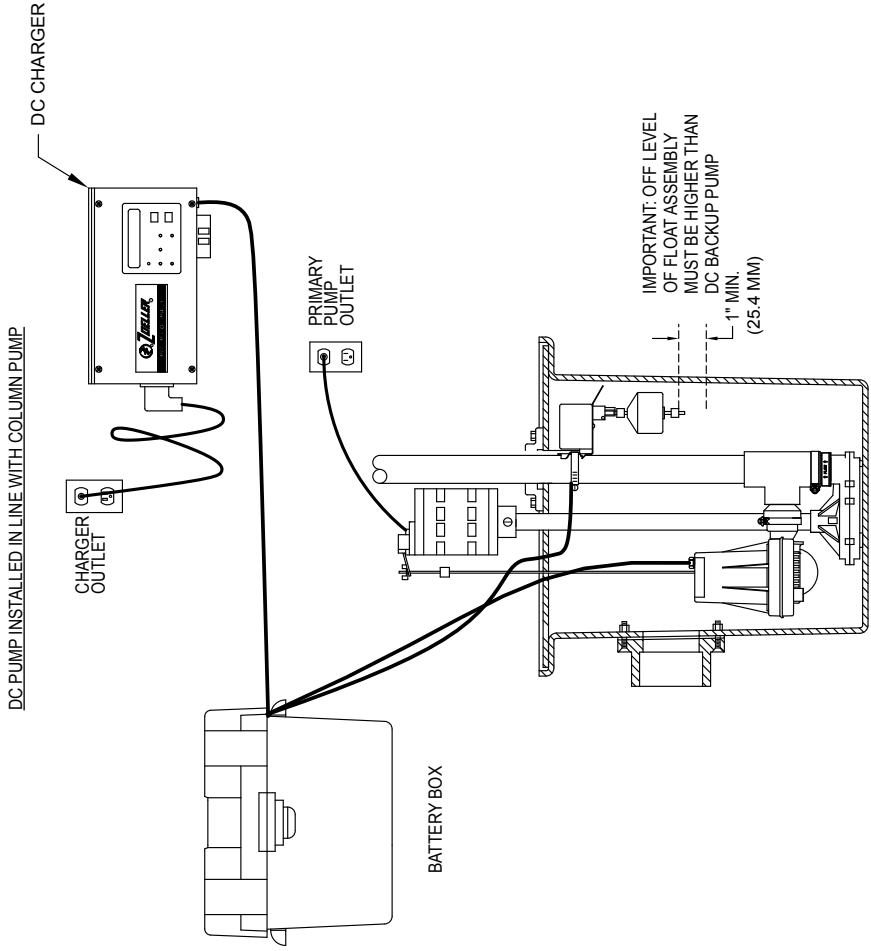

FIGURE 2

EXPLODED VIEW - DC PUMP

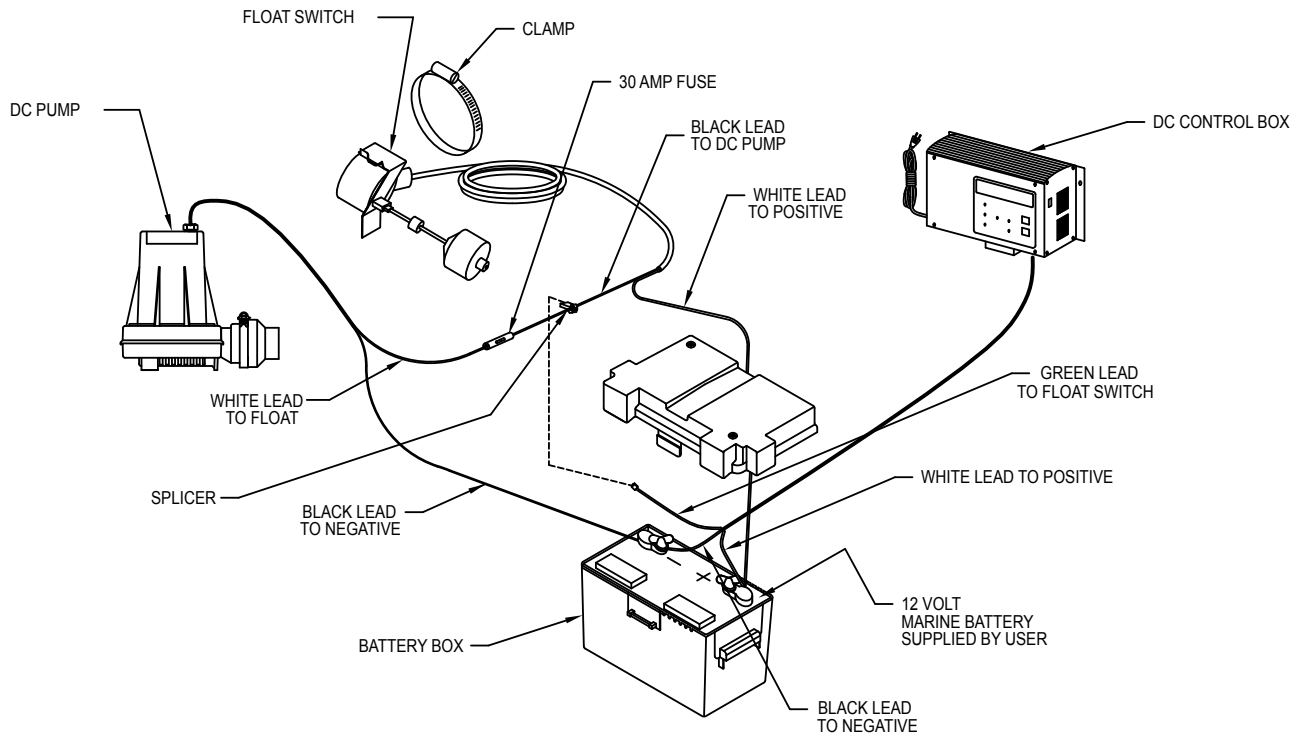

FIGURE 3

SK2961

PUMP ASSEMBLY

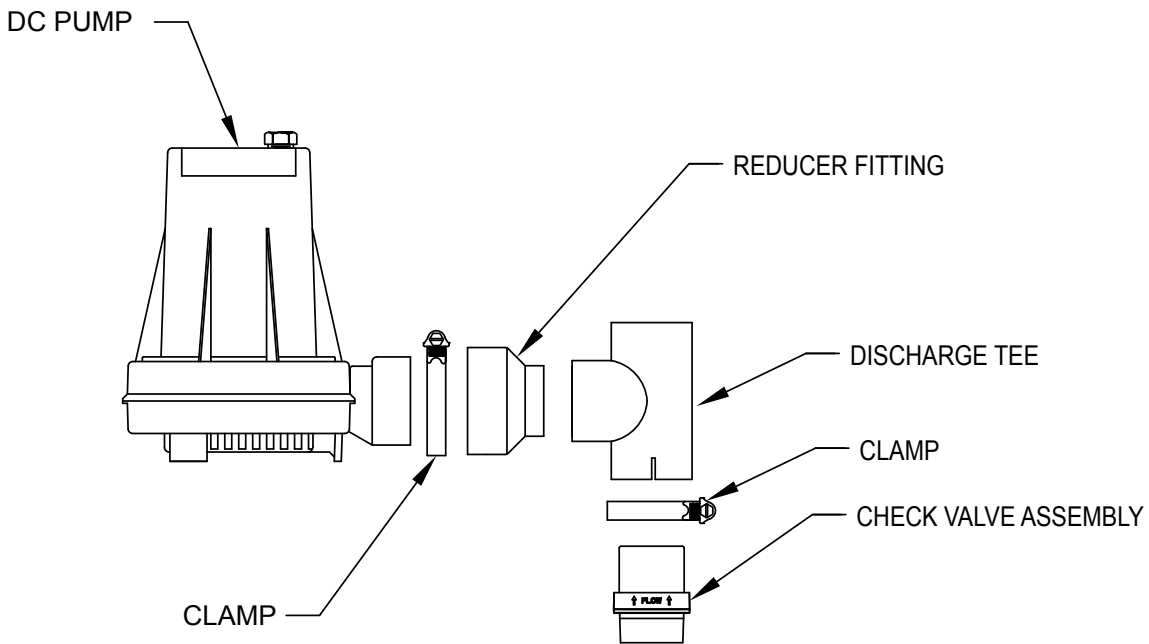

FIGURE 4

SK2962

FLOAT SWITCH

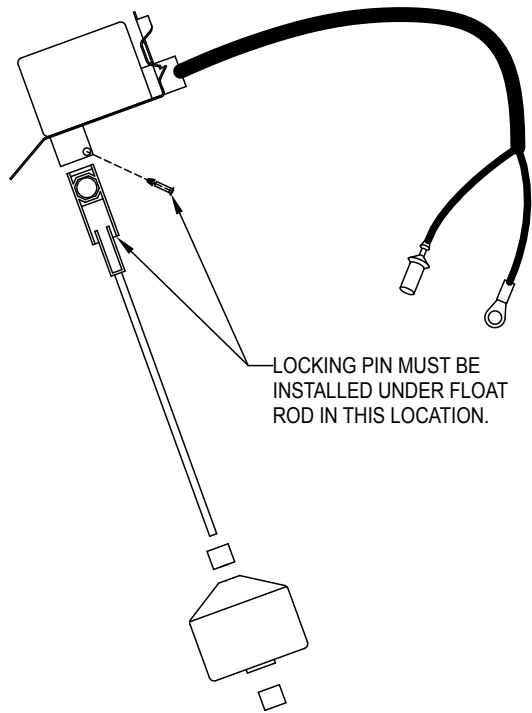

FIGURE 5

SK2503

CONTROL CHARGER

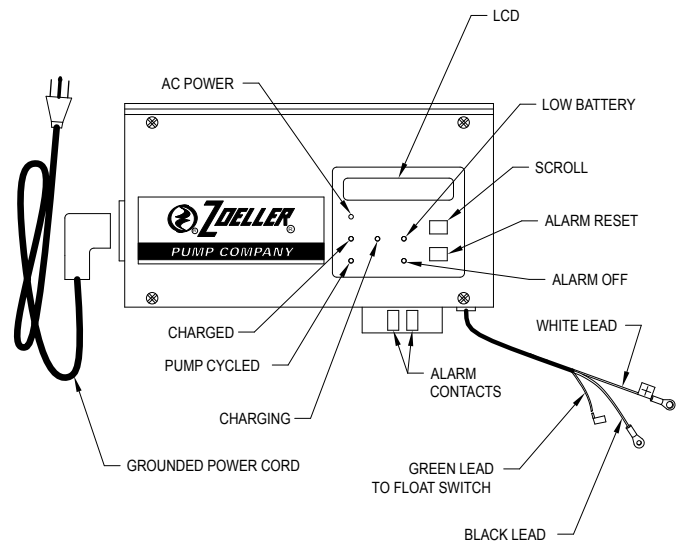

FIGURE 6

SK2958

LCD DISPLAY AND KEYPAD FUNCTIONS

There are two buttons on the front of the charger:

- The scroll button is used to cycle through the information on the LCD screen.
- The alarm reset button:
 - Can be pressed to clear alarm buzzer, light and/or display.
 - Can be held for longer than 3 seconds to silence the buzzer for a 24-hour period.

The LCD screen will display information about the system by simply pressing the scroll button:

- The bottom line of the LCD will always display the battery voltage and current going to the battery, if charging.
- The alarm screen shows current alarms.
- The cycle counter screen shows how many times the DC float has been activated.
- The AC power loss counter screen shows how many times the AC power has been removed from the charger.
- Optional: a screen may also show the name and number of a service provider.

The 6 LED lights also display information about the charger at a glance:

- The red *AC power* light will be on if AC power is connected, and it will blink if AC power is not connected.
- The green *charged* light indicates a full battery, ready for operation.
- The yellow *charging* light indicates power going to the battery.
- The red *low battery* light blinks when the battery is below 10.8 volts and rapidly blinks when the battery is below 8.4 volts.
- The yellow *pump cycled* light will blink when the float is activated, and becomes solid after 3 seconds.

NOTE: The pump activates when float activates. Alarm is delayed to reduce nuisance alarms.

- The yellow *alarm off* light indicates the buzzer is currently silenced.
- Removing AC & DC power from charger will restore all factory defaults, including resetting the alarm counters.

THE AQUANOT® BATTERY

There are millions of batteries manufactured each year, so it is impossible to guarantee consistent quality. A defective battery will never become fully charged and may damage the charging circuits of the Control. It is for this reason that Zoeller offers its own line of batteries. We offer both a Water/Acid Deep-Cycle Battery and maintenance-free AGM battery which can run the pump continuously for over 7½ hours. These times are based on continuous pumping at 8' (2.4 mm) of static head. Actual times will vary depending on static head, volume of water entering the pit, and the condition of the battery.

Follow these recommendations:

- Use a B.C.I. size 27 deep-cycle battery, 175 minute reserve capacity, or larger
- Do NOT use a "maintenance-free" battery unless it is an AGM battery
- Replace your battery every 3 years
- Do not let corrosion build up on the battery terminals
- To check specific gravity, follow the instructions on a hydrometer (wet cell batteries only)
- Use of included plastic battery box is recommended to keep battery safe and clean.

PROTECT YOUR WARRANTY:

- Water level in batteries must be checked once a month (wet cell batteries only)

CARBON MONOXIDE DETECTORS

Whether you have a Aquanot® Backup Pump System, or a competitive brand, all use batteries that give off gaseous by-products when charging. Some of these by-products can produce a rotten egg odor. Also, some of these by-products can cause a CO detector to falsely activate. In order to help prevent false activation, Zoeller Company recommends moving the battery as far apart from the CO detector as possible or, if necessary, vent the battery to the exterior. Zoeller Company provides the previous statements only as guidelines to help prevent false activation of the CO detector. In no way are they meant to supersede the instructions that accompany the detector nor do they supersede advice from the CO detector manufacturer.

If the audible alarm associated with your CO detector is activated, we recommend the following actions:

- 1) Take immediate action for personal safety as recommended in the CO detector literature.
- 2) Contact the appropriate agency to determine if the CO is being produced by your furnace, water heater, or any other device which uses natural gas.
- 3) If you are certain that no CO is being produced, then a charging battery may be producing gaseous by-products which are causing the CO detector to activate. Contact the manufacturer and ask for recommendations as to what can be done to prevent the alarm activation.

DECLARATION OF CONFORMITY

Zoeller Pump Company declares under our sole responsibility that the Aquanot Model 508 to which this declaration relates, is in conformity with the Council Directives on the approximation of the laws of the EC Member States relating to:

- Electrical equipment designated for use with certain voltage limits (Directive 2006/95/EC), standards used: EN 60335-1:2004+A1+A11+A12+A2+A13+A14+A15 and EN 60335-2-29:2004+A2
- Electromagnetic Compatibility (Directive 2004/108/EC), standards used: EN 55014-1:2006+A2:2011, EN 55014-2:2015, EN 61000-3-2:2014, EN 61000-3-3:2013
- Restrictive and Hazardous Substances RoHS (Directive 2011/65/EU), standards used: EN 50581-2012
- Waste Electrical and Electronic Equipment WEEE (Directive 2012/19/EU)



PUMP COMPANY

MAIL TO: P.O. BOX 16347 • Louisville, KY 40256-0347
SHIP TO: 3649 Cane Run Road • Louisville, KY 40211-1961
(502) 778-2731 • 1 (800) 928-PUMP • FAX (502) 774-3624

Your Peace of Mind is Our Top Priority®

**visit our web site:
www.zoeller.com**