

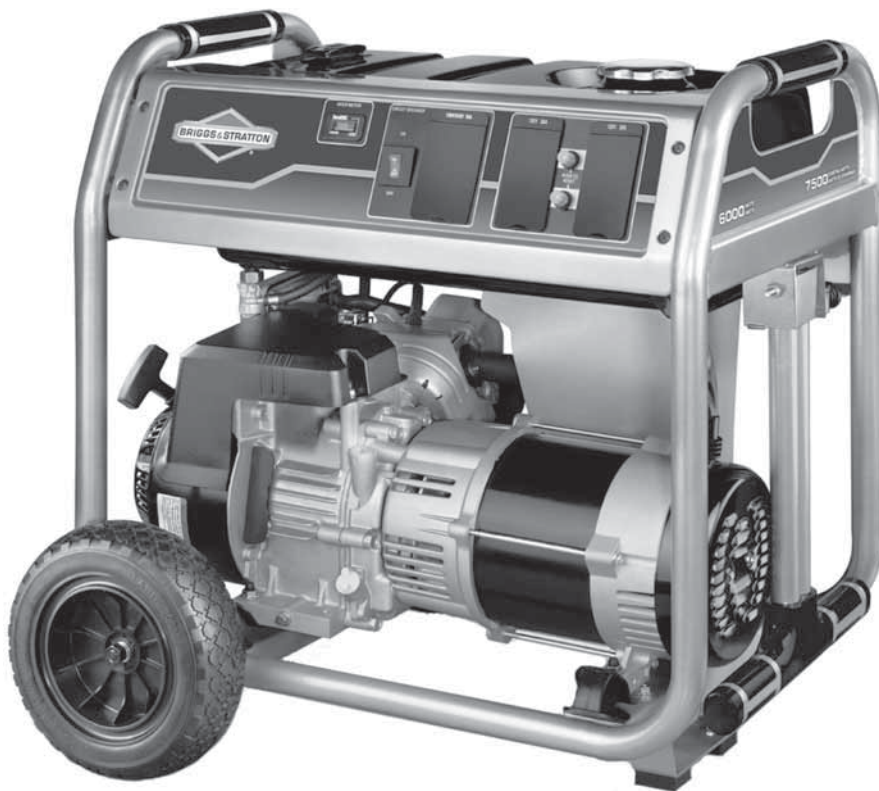

Illustrated Parts List

Portable Generator



This generator is rated in accordance with CSA (Canadian Standards Association) standard C22.2 No. 100-94 (motor and generators).

Questions? Help is just a moment away!
Preguntas? La ayuda es justa un momento lejos!

Call: Portable Generator Helpline

Llame: Línea Directa del Generador portátil - 1-800-732-2989 M-F 8-5 CST

Model / Modelo

Mfg. No.	Description / Descripción
030469-0	6,000 Watt Briggs & Stratton

Manual Part No. 313536

Revision A

Rev. Date: 10/27/2011

Not for
Reproduction

PRODUCT COMPONENTS	PAGES
Main Unit	4
Control Panel	6
Wheel Kit	7
Torque Specification Chart	Inside Back Cover

Not for
Reproduction

Main Unit

313309

NOTE: Unless noted otherwise, use the standard hardware torque specification chart.

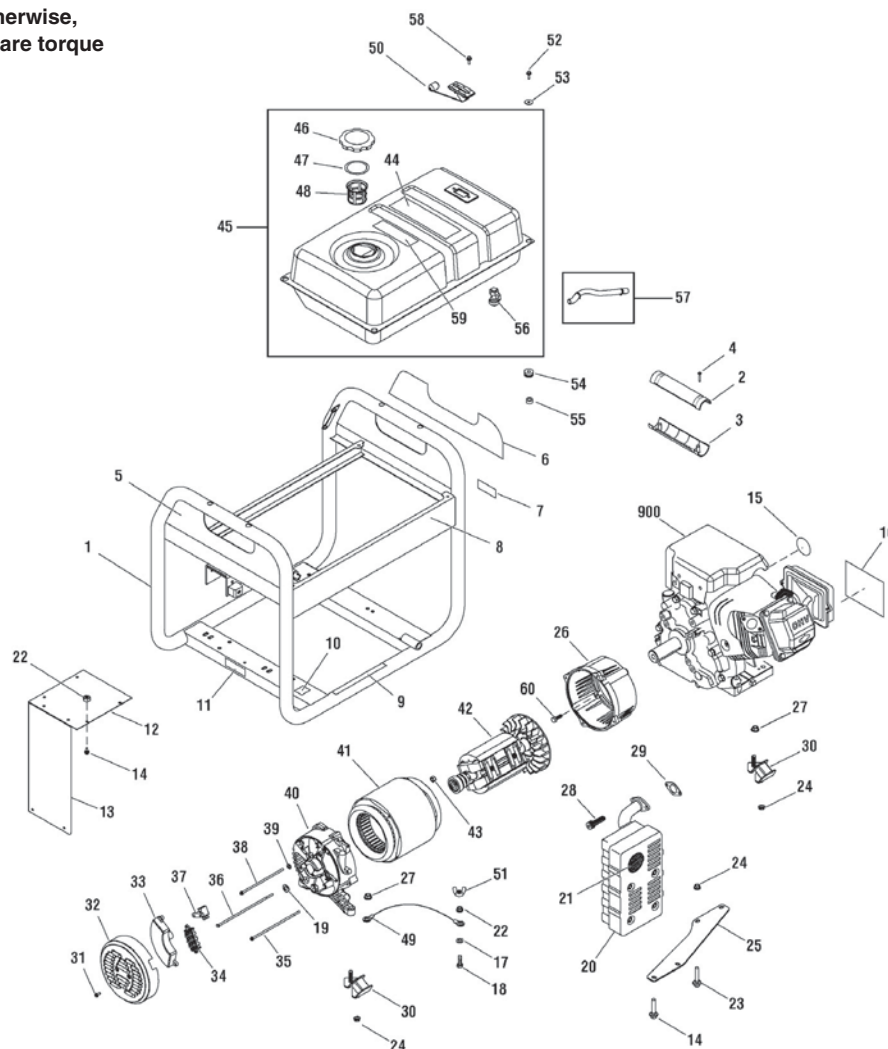

REF.	PART NO.	DESCRIPTION	REF.	PART NO.	DESCRIPTION
1	313313GS	CRADLE	18	47411GS	SCREW
2	313321GS	GRIP, Handle	19	312045GS	WASHER
3	313322GS	GRIP, Handle	20	189008GS	MUFFLER
4	75477GS	SCREW	21	83083GS	SCREEN
5	312568GS	DECAL	22	197861GS	NUT
6	312569GS	DECAL	23	311987GS	SCREW
7	197798GS	DECAL	24	67989GS	NUT
8	312570GS	DECAL	25	189009GS	SUPPORT, Muffler
9	200310GS	DECAL	26	207822GS	ADAPTER, Engine
10	B4986GS	DECAL	27	193747GS	NUT
11	200311GS	DECAL	28	204885GS	SCREW
12	313043GS	HEATSHIELD	29	695398	GASKET
13	310718GS	HEATSHIELD	30	312012GS	MOUNT, Vibration
14	209775GS	BOLT	31	207824GS	SCREW
15	276928	DECAL	32	313364GS	END COVER
16	312561GS	DECAL	33	312038GS	VOLTAGE REGULATOR
17	22097GS	WASHER			

Footnotes

** Contact Engine Manufacturer

The above parts group applies to the following Mfg. Nos.:

030469-0 - 6,000 Watt Briggs & Stratton

Main Unit

313309

NOTE: Unless noted otherwise, use the standard hardware torque specification chart.

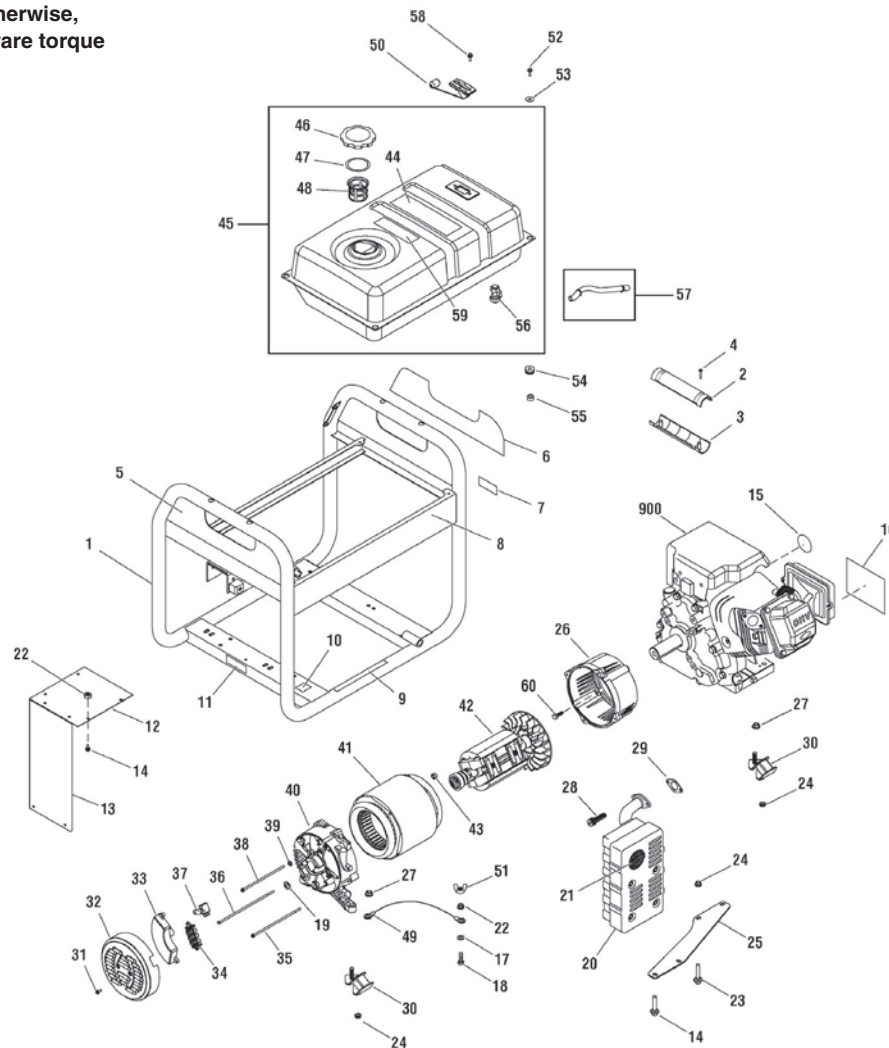

REF.	PART NO.	DESCRIPTION	REF.	PART NO.	DESCRIPTION
34	312041GS	TERMINAL BLOCK	51	87680GS	NUT
35	312042GS	BOLT	52	209421GS	BOLT
36	313323GS	BOLT	53	312005GS	WASHER
37	209441GS	BRUSH ASSEMBLY	54	312006GS	GROMMET
38	312046GS	BOLT	55	312010GS	SPACER
39	49226GS	WASHER	56	209417GS	VALVE, Fuel
40	209423GS	CARRIER, Bearing	57	791745	FUEL HOSE (Cut to fit)
41	313319GS	STATOR	58	197896GS	SCREW
42	313316GS	ROTOR	59	188333GS	DECAL
43	207878GS	NUT	60	313368GS	BOLT
44	194984GS	DECAL	900	----	** ENGINE
45	313311GS	TANK, Fuel	--	312491GS	MANUAL, Operator's (Not Illustrated)
46	311990GS	CAP, Fuel			
47	209939GS	SEAL			
48	311991GS	FILTER, Screen			
49	312040GS	WIRE			
50	311992GS	GAUGE, Fuel			

Footnotes

** Contact Engine Manufacturer

The above parts group applies to the following Mfg. Nos.:

030469-0 - 6,000 Watt Briggs & Stratton

Control Panel

312970

NOTE: Unless noted otherwise,
use the standard hardware torque
specification chart.

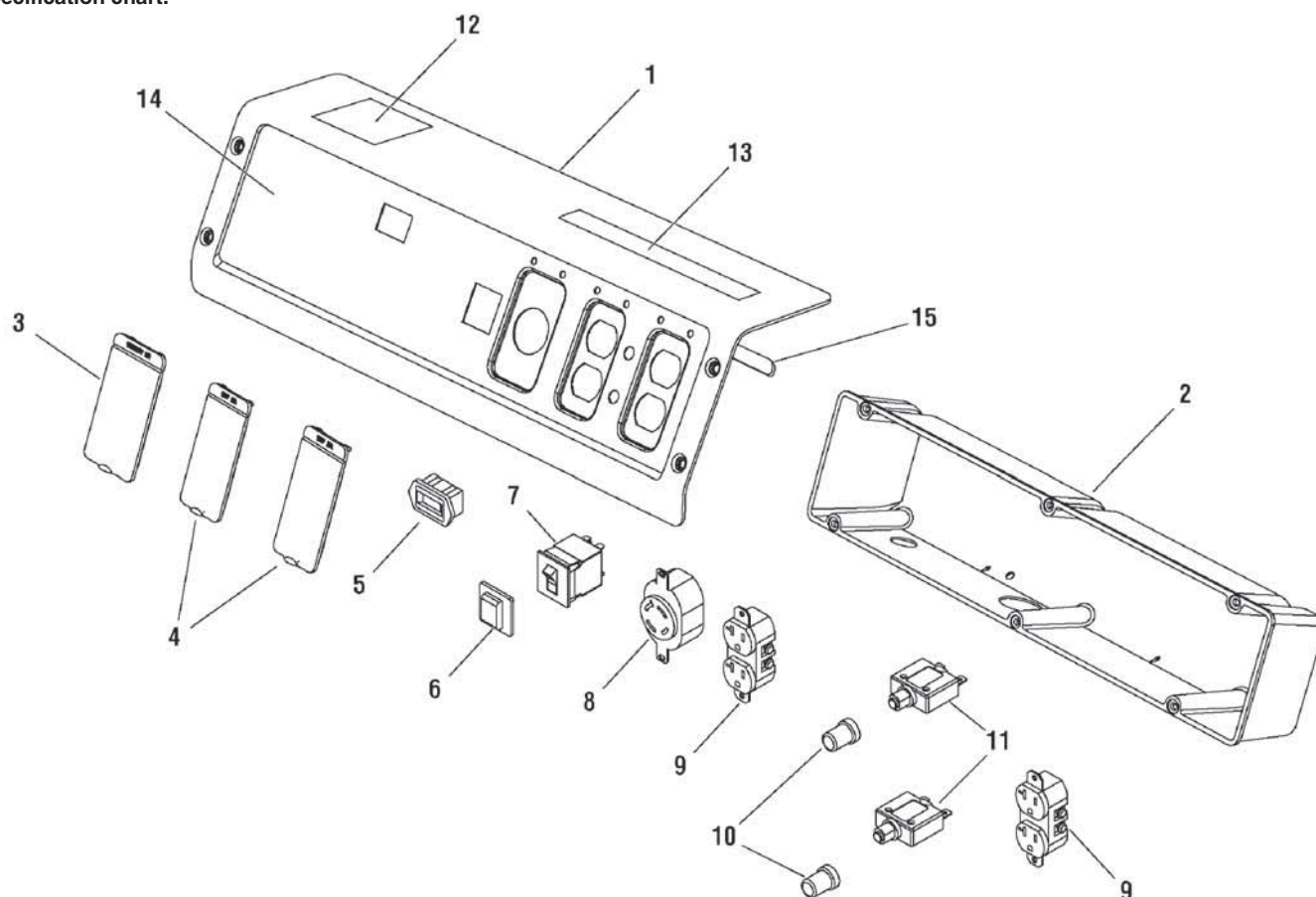

REF. PART NO.	DESCRIPTION	REF. PART NO.	DESCRIPTION
1	313287GS PANEL, Control		
2	312978GS BOX, Control Panel		
3	312030GS COVER, Outlet		
4	312031GS COVER, Outlet		
5	198245GS METER, Hour		
6	191481GS BOOT		
7	209677GS BREAKER, Circuit, 25A		
8	43437GS OUTLET, 120/240V TL30A		
9	68759GS OUTLET, 120V 20A		
10	84198GS BOOT, Circuit Breaker		
11	202394GS BREAKER, Circuit, 20A		
12	202997GS DECAL		
13	312572GS DECAL		
14	312571GS DECAL		
15	312969GS TRIM, Edge		

Footnotes

The above parts group applies to the following Mfg. Nos.:

030469-0 - 6,000 Watt Briggs & Stratton

Wheel Kit

312967

NOTE: Unless noted otherwise, use the standard hardware torque specification chart.

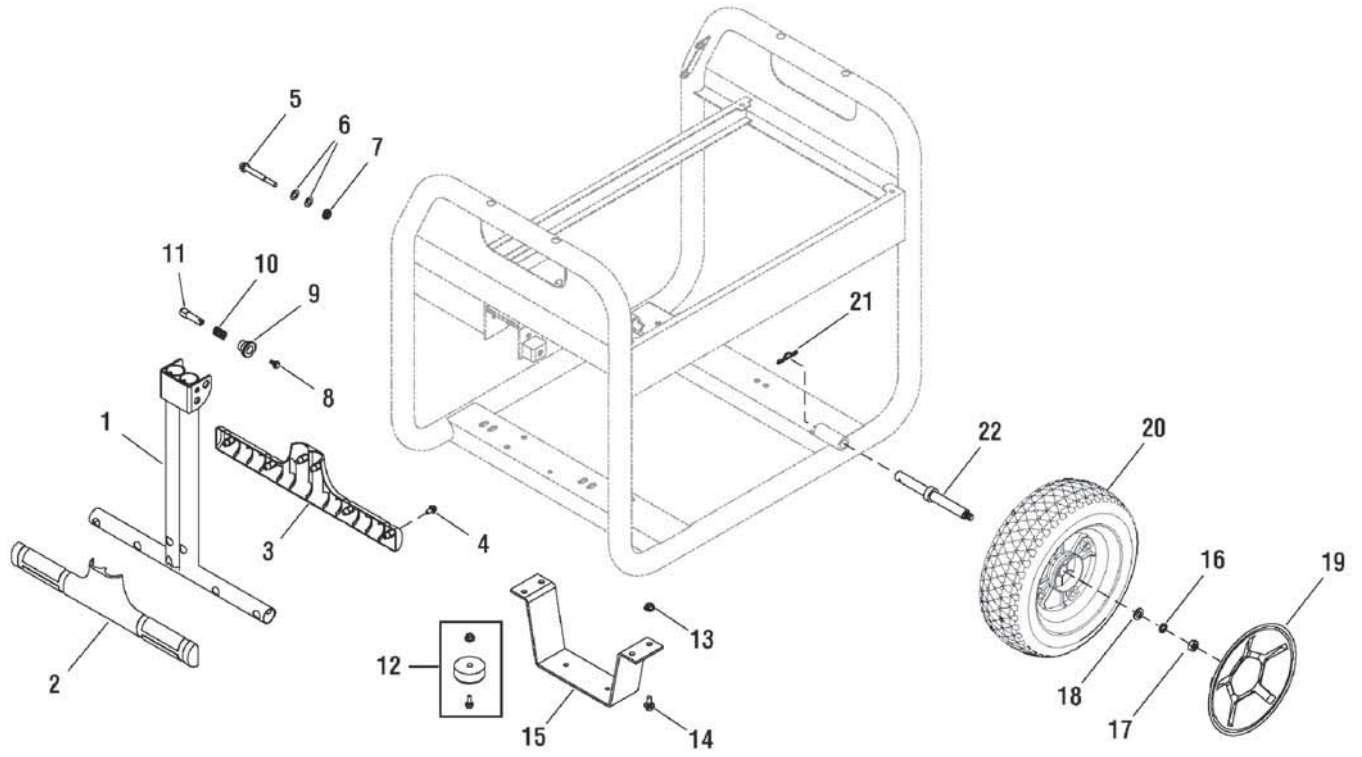

REF. PART NO.	DESCRIPTION	REF. PART NO.	DESCRIPTION		
1	312973GS	HANDLE	18	209419GS	WASHER
2	313284GS	GRIP, Handle	19	316418GS	HUBCAP
3	313283GS	GRIP, Handle	20	209322GS	WHEEL
4	75477GS	SCREW	21	5025210YP	PIN, Hair, .0915 x 1-7/8
5	312974GS	BOLT	22	312972GS	AXLE
6	187104GS	WASHER			
7	49820GS	NUT			
8	207825GS	BOLT			
9	312016GS	KNOB			
10	312015GS	SPRING			
11	312017GS	PIN			
12	192310GS	MOUNT, Vibration			
13	52857GS	NUT			
14	42568GS	BOLT			
15	312968GS	SUPPORT, Leg			
16	46526GS	WASHER			
17	209413GS	NUT			

Footnotes

The above parts group applies to the following Mfg. Nos.:

030469-0 - 6,000 Watt Briggs & Stratton

Not for
Reproduction

Not for
Reproduction

Not for
Reproduction

Hardware Identification & Torque Specifications

Torque Specification Chart								
FOR STANDARD METRIC MACHINE HARDWARE (Tolerance ± 20%)								
Property Class	5.6		8.8		10.9		12.9	
	Class 5.6		Class 8.8		Class 10.9		Class 12.9	
Size Of Hardware	in/lbs		in/lbs		in/lbs		in/lbs	
	ft/lbs	Nm.	ft/lbs	Nm.	ft/lbs	Nm.	ft/lbs	Nm.
M3	5.88	.56	13.44	1.28	19.2	1.80	22.92	2.15
M4	13.44	1.28	30.72	2.90	43.44	4.10	52.56	4.95
M5	26.4	2.50	60.96	5.75	5.97	8.10	7.15	9.7
M6	44.64	4.3	7.3	9.9	10.3	14	12.1	16.5
M7	5.2	7.1	12.1	16.5	16.9	23	19.9	27
M8	7.7	10.5	17.7	24	25	34	29	40
M10	15	21	35	48	50	67	59	81
M12	26	36	61	83	86.2	117	103	140
M14	42	58	101	132	136	185	162	220
M16	64	88	147	200	210	285	250	340
M18	89	121	202	275	287	390	346	470
M20	126	171	290	390	405	550	486	660
M22	169	230	390	530	559	745	656	890
M24	217	295	497	375	708	960	840	1140
M27	320	435	733	995	1032	1400	1239	1680
M30	435	590	995	1350	1401	1900	1681	2280
M33	590	800	1349	1830	1902	2580	2278	3090
M36	759	1030	1740	2360	2441	3310	2935	3980
M39	988	1340	2249	3050	3163	4290	3798	5150

The guides and ruler furnished below are designed to help you select the appropriate hardware.



Nut, M8

Thread Diameter (mm)
Inside Diameter (in)
Threads per inch

Nut, 1/2-16

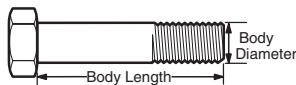

Screw, M8- 1.25 x 25

Thread Diameter (mm)
Body Diameter
Distance between threads (mm)
Threads per inch
Body Length (mm)
Body Length (in)

Screw, 1/2- 16 x 2

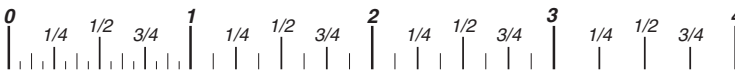

Standard Hardware Sizing

When a washer or nut is identified as 1/2" (M8), this is the *Nominal size*, meaning the *inside diameter* is 1/2 inch (8mm metric thread diameter); if a second number is present it represents the *threads per inch* (distance between threads).

When bolt or capscrew is identified as 1/2 - 16 x 2" (M8 - 1.25 x 50), this means the *Nominal size*, or body diameter is 1/2 inch (8mm metric thread diameter), the second number, 16, represents the *threads per inch*, (1.25 thread diameter). The final number is the body length of the bolt or screw, 2 inches (50mm).

Torque Specification Chart						
FOR STANDARD MACHINE HARDWARE (Tolerance ± 20%)						
Hardware Grade	No Marks		SAE Grade 5		SAE Grade 8	
	SAE Grade 2		SAE Grade 5		SAE Grade 8	
Size Of Hardware	in/lbs		in/lbs		in/lbs	
	ft/lbs	Nm.	ft/lbs	Nm.	ft/lbs	Nm.
8-32	19	2.1	30	3.4	41	4.6
8-36	20	2.3	31	3.5	43	4.9
10-24	27	3.1	43	4.9	60	6.8
10-32	31	3.5	49	5.5	68	7.7
1/4-20	66	7.6	8	10.9	12	16.3
1/4-28	76	8.6	10	13.6	14	19.0
5/16-18	11	15.0	17	23.1	25	34.0
5/16-24	12	16.3	19	25.8	29	34.0
3/8-16	20	27.2	30	40.8	45	61.2
3/8-24	23	31.3	35	47.6	50	68.0
7/16-14	30	40.8	50	68.0	70	95.2
7/16-20	35	47.6	55	74.8	80	108.8
1/2-13	50	68.0	75	102.0	110	149.6
1/2-20	55	74.8	90	122.4	120	163.2
9/16-12	65	88.4	110	149.6	150	204.0
9/16-18	75	102.0	120	163.2	170	231.2
5/8-11	90	122.4	150	204.0	220	299.2
5/8-18	100	136	180	244.8	240	326.4
3/4-10	160	217.6	260	353.6	386	525.0
3/4-16	180	244.8	300	408.0	420	571.2
7/8-9	140	190.4	400	544.0	600	816.0
7/8-14	155	210.8	440	598.4	660	897.6
1-8	220	299.2	580	788.8	900	1,244.0
1-12	240	326.4	640	870.4	1,000	1,360.0

NOTES

- These torque values are to be used for all hardware excluding: locknuts, self-tapping screws, thread forming screws, sheet metal screws and socket head setscrews.
- Recommended seating torque values for locknuts:
 - for prevailing torque locknuts - use 65% of grade 5 torques.
 - for flange whizlock nuts and screws - use 135% of grade 5 torques.
- Unless otherwise noted on assembly drawings, all torque values must meet this specification.

Common Hardware Types

Hex Head Capscrew



Washer



Lockwasher

Carriage Bolt

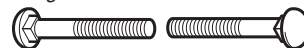

Hex Nut

Wrench & Fastener Size Guide

1/4" Bolt or Nut Wrench—7/16"	5/16" Bolt or Nut Wrench—1/2"	3/8" Bolt or Nut Wrench—9/16"	7/16" Bolt or Nut Wrench (Bolt)—5/8" Wrench (Nut)—11/16"	1/2" Bolt or Nut Wrench—3/4"
M6 Bolt or Nut Wrench—10mm	M8 Bolt or Nut Wrench—13mm	M10 Bolt or Nut Wrench—17mm	M12 Bolt or Nut Wrench—19mm	M14 Bolt or Nut Wrench—22mm



Not for
Reproduction

Briggs & Stratton Power Products Group

Copyright© 2011 Briggs & Stratton Power Products Group. All rights reserved. No part of this page can be reproduced or transmitted in any form by any means without the express written permission of Briggs & Stratton Power Products Group.