



TYPE "B" SINGLE STAGE CENTRIFUGAL PUMP Electric Motor Drive

Section	CC
Page	250.1
Date	January 1, 2004
Supersedes 6/1/95	

CAST IRON IMPELLER

B4EPM

Flanged Case

Packing Construction

TABLE I

B/M No.	HP	PH	RPM	"U" Dim.	Imp. Dia.	Imp. No.
B51726	15	3	1800	1-1/4"	9.88"	M07704
B51727	20	3	1800	1-1/4"	10.44"	M04821

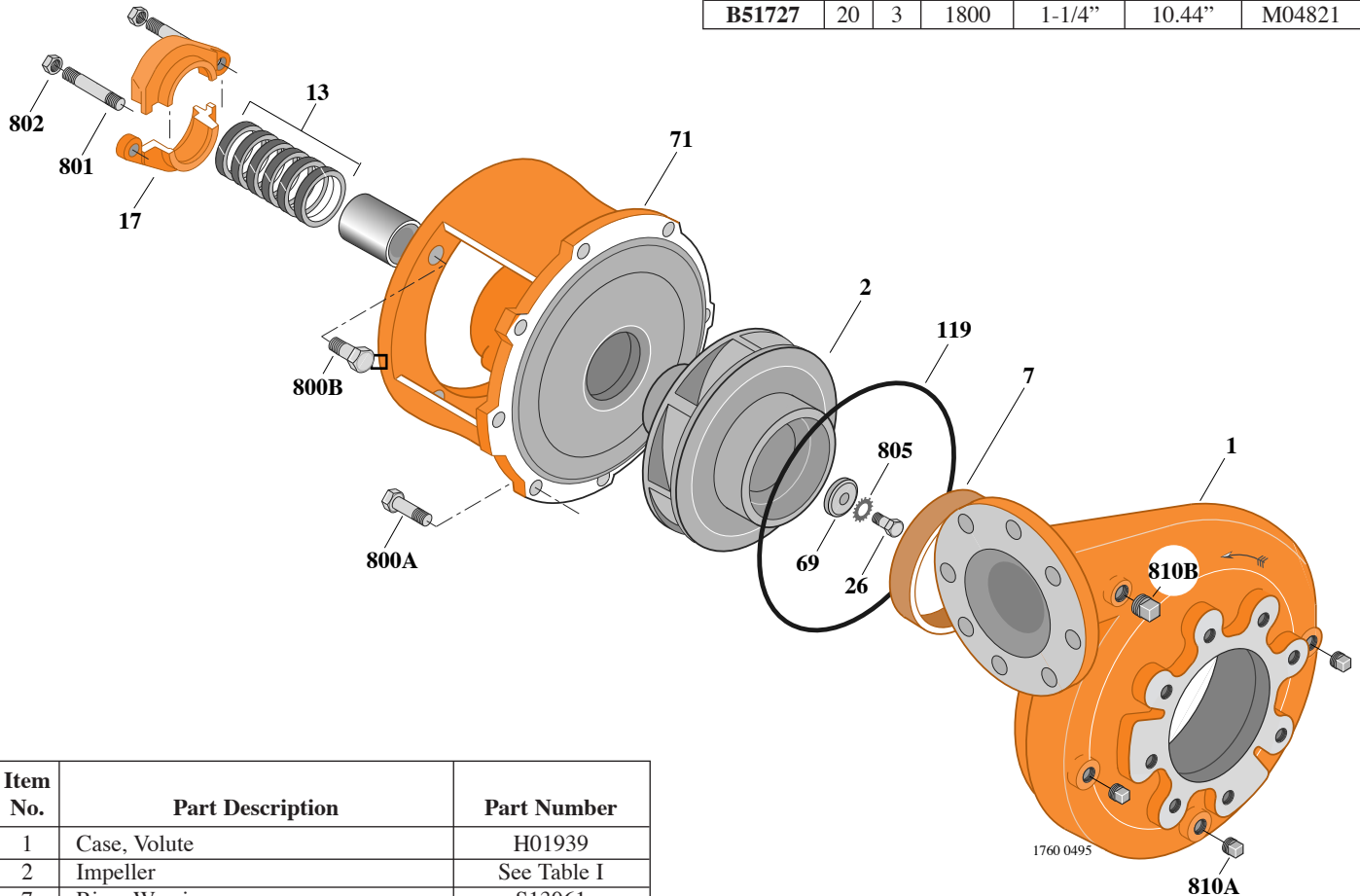

Item No.	Part Description	Part Number
1	Case, Volute	H01939
2	Impeller	See Table I
7	Ring, Wearing	S13061
13	Rings, Packing (Set of 6)	S13470
14	Sleeve, Shaft	S05149
17	Gland, Packing	B82470
26	Screw, Impeller 1/2 - 13 x 1-3/4"	S23625
32	Key, 1/4 x 2-1/4" (See Note)	S23677
69	Washer, Impeller	S06319
71	Bracket	See Table II
119	O-Ring	S13760
801	Stud, 3/8 - 16 x 2-1/2" (2 Req.)	S04438
802	Nut, Hex 3/8 - 16 (2 Req.)	S23343
805	Washer, Lock	S23038
800A	Capscrew, 1/2 - 13 x 1-1/4" (8 Req.)	S26914
800B	Capscrew, 1/2 - 13 x 1-1/2" (4 Req.)	S26916
810A	Plug, Pipe 1/4 NPT (3 Req.)	S23715
810B	Plug, Pipe 1/2 NPT (2 Req.)	S23717

TABLE II

HP	PH	Bracket No.	"AK" Fit	"U" Dim.	Motor Frame
15	3	L03637	8-1/2"	1-1/4"	254JP
20	3	L03637	8-1/2"	1-1/4"	256JP

NOTE: For an explanation of the tabulated material found on this page and for impeller key location, refer to *Supplement A* located at the beginning of this section.



TYPE "B" SINGLE STAGE CENTRIFUGAL PUMP Electric Motor Drive

Section	CC
Page	250.2
Date	January 1, 2004
Supersedes 6/1/95	

CAST IRON IMPELLER

B4EPMS

Flanged Case

Mechanical Shaft Seal Construction

TABLE I

B/M No.	HP	PH	RPM	"U" Dim.	Imp. Dia.	Imp. No.
B54154	15	3	1800	1-1/4"	9.88"	M07704
B54155	20	3	1800	1-1/4"	10.44"	M04821

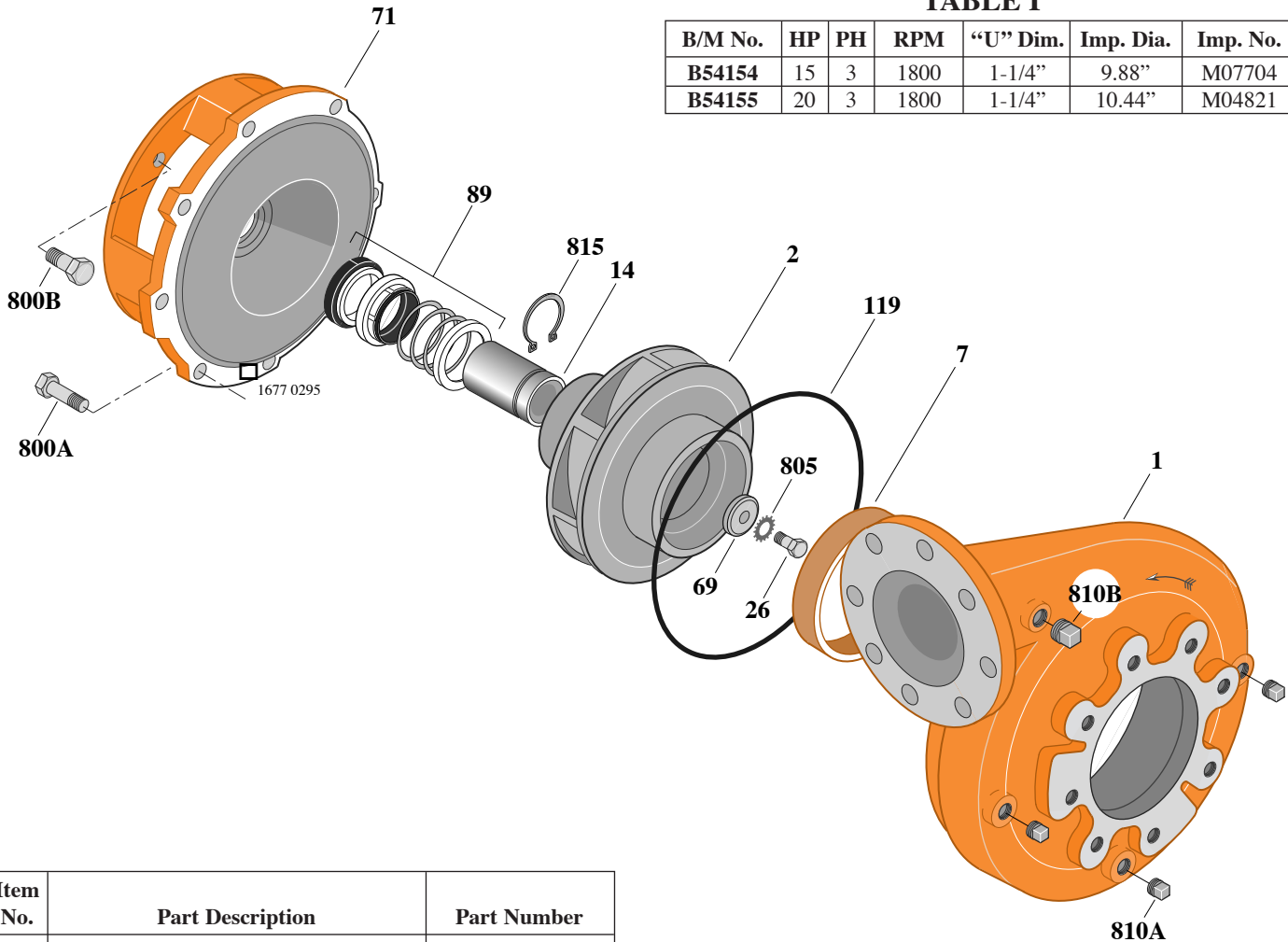

Item No.	Part Description	Part Number
1	Case, Volute	H01939
2	Impeller	See Table I
7	Ring, Wearing	S13061
14	Sleeve, Shaft	S18869
26	Screw, Impeller 1/2 - 13 x 1-3/4"	S23625
32	Key, 1/4 x 2-1/4" (See Note)	S23677
69	Washer, Impeller	S06319
71	Bracket	See Table II
89	Seal, Mechanical Shaft	S32015
119	O-Ring	S13760
800A	Capscrew, 1/2 - 13 x 1-1/4" (8 Req.)	S26914
800B	Capscrew, 1/2 - 13 x 1" (4 Req.)	S26912
805	Washer, Lock	S23038
810A	Plug, Pipe 1/4 NPT (3 Req.)	S23715
810B	Plug, Pipe 1/2 NPT (2 Req.)	S23717
815	Ring, Retaining	S16767

TABLE II

HP	PH	Bracket No.	"AK" Fit	"U" Dim.	Motor Frame
15	3	L04616	8-1/2"	1-1/4"	254JM
20	3	L04616	8-1/2"	1-1/4"	256JM

NOTE: For an explanation of the tabulated material found on this page and for impeller key location, refer to *Supplement A* located at the beginning of this section.



TYPE "B" SINGLE STAGE CENTRIFUGAL PUMP Electric Motor Drive

Section	CC
Page	250.3
Date	January 1, 2004
Supersedes/New	

BRONZE IMPELLER

B4EPMS

Flanged Case

Mechanical Shaft Seal Construction

TABLE I

B/M No.	HP	PH	RPM	"U" Dim.	Imp. Dia.	Imp. No.
B76767	15	3	1800	1-1/4"	9.88"	M11557
B76768	20	3	1800	1-1/4"	10.44"	M11558

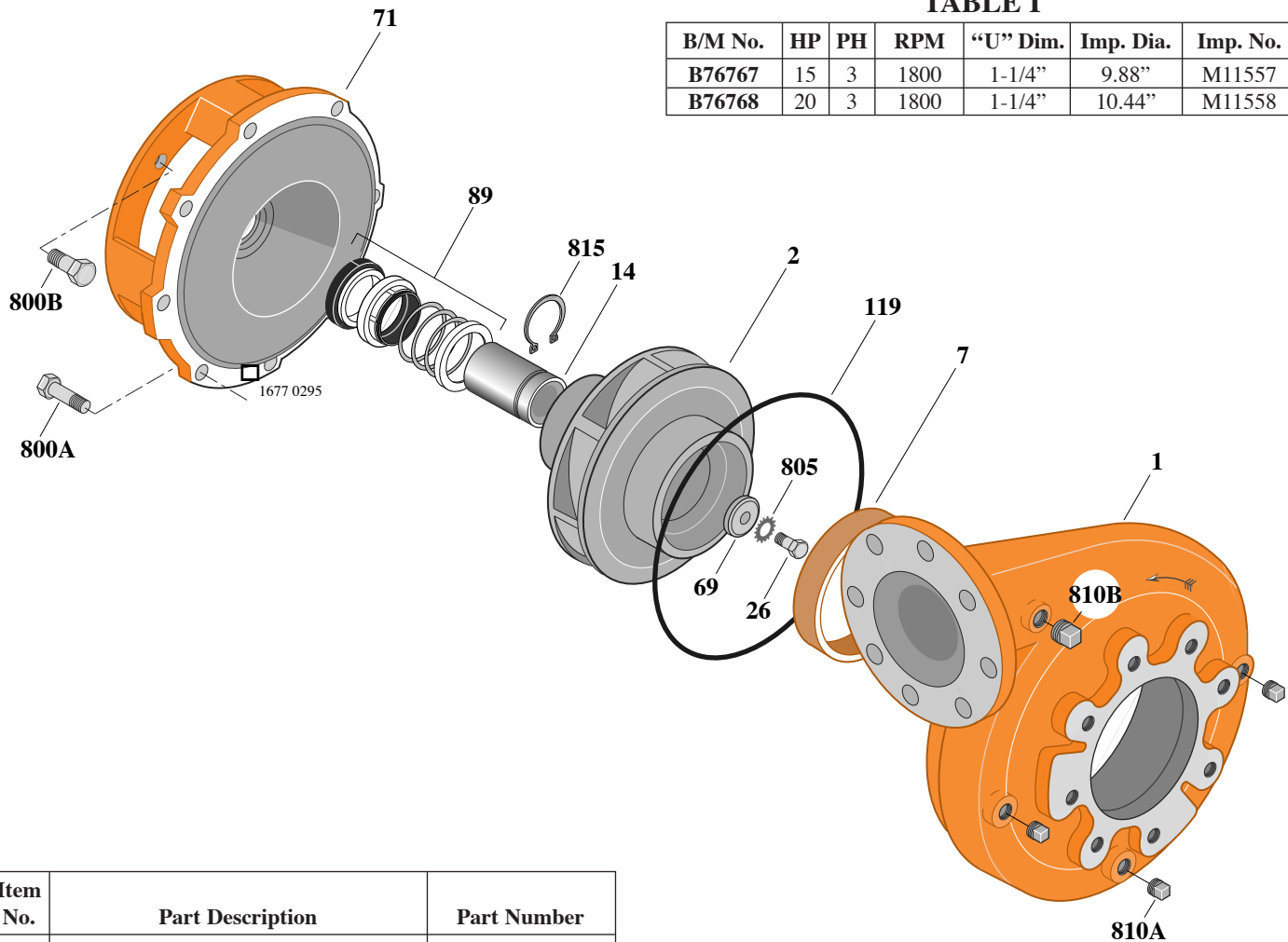

Item No.	Part Description	Part Number
1	Case, Volute	H01939
2	Impeller	See Table I
7	Ring, Wearing	S13061
14	Sleeve, Shaft	S18869
26	Screw, Impeller 1/2 - 13 x 1-3/4"	S23625
32	Key, 1/4 x 2-1/4" (See Note)	S23677
69	Washer, Impeller	S06319
71	Bracket	See Table II
89	Seal, Mechanical Shaft	S32015
119	O-Ring	S13760
800A	Capscrew, 1/2 - 13 x 1-1/4" (8 Req.)	S26914
800B	Capscrew, 1/2 - 13 x 1" (4 Req.)	S26912
805	Washer, Lock	S23038
810A	Plug, Pipe 1/4 NPT (3 Req.)	S23715
810B	Plug, Pipe 1/2 NPT (2 Req.)	S23717
815	Ring, Retaining	S16767

TABLE II

HP	PH	Bracket No.	"AK" Fit	"U" Dim.	Motor Frame
15	3	L04616	8-1/2"	1-1/4"	254JM
20	3	L04616	8-1/2"	1-1/4"	256JM

NOTE: For an explanation of the tabulated material found on this page and for impeller key location, refer to *Supplement A* located at the beginning of this section.