HJ BLE Module

SPEC

V1.0

Index

1. Summary	3
1.1 Functions	3
1.2 Application	3
2. Electrical characters	4
3. RF performance	5
4. Pin assignment	6
4.1 pin distribution	6
4.2 Pin definition	7
5. Reference Design	9
5.1 Reference schematic	9
5.2 Module packet	10
5.3 Warning	11

1. Summary

1.1 Functions

- 32-bit MCU, 128KB Flash, 16KB SRAM
- Bluetooth 4.2.
- -92dBm sensitivity
- Support I2C connector
- Support UART connector
- Support SPI connector
- Support ADC connector
- Support DMIC、AMIC connector
- Support USB connector
- PCB antenna

1.2 Application

Fitness

Wearable products

Smart home

2. Electrical characters

Table 1 Supply voltage

Symbol	Typical	Minimum	Maximum	Units
VDD	3.3V	2.7	3.6	V

Table 2 Digital IO specifications

Symbol	Minimum	Normal	Maximum	Units
V _{IH}	0.7VDD	-	VDD	V
V _{IL}	VSS	-	0.3VDD	V
V _{OH}	VDD-0.3	-	VDD	V
V _{OL}	VSS	-	0.3	V

Table 3 Temperature specifications

Item	Minimum	Maximum	Units
Storage	-65	+150	°C
Soldering	-	+260	°C

Table 4 DC characteristics

工作模式 (Item)	典型值 (typ)	单位 (Units)
发射模式 Tx current (1KB/s) @0dBm	10.8	mA
接收模式 Rx current (1KB/s)	9.8	mA
睡眠 (Sleep current)	150	uA
挂起 (Suspend current)	10	uA
深睡眠 (Deepsleep)	1	uA

3. RF performance

Table 5 RF section

Item	Symbol	Minimum	Normal	Maximum	Units
Sensitivity	1Mbps	-93	-92	-90	dBm
Frequency offset tolerance	-	-300	-	+300	KHz
Co-channel rejection	-	-	-7	-	dB
In-band blocking rejection	±1 MHz offset	-	12	-	dB
	-2 MHz offset	-	47	-	dB
	-3 MHz offset	-	48	-	dB
	+3 MHz offset	-	50	-	dB
	>4 MHz offset	-	52	-	dB
Image rejection	-	-	44	-	dB

Table 6 BT section

Item	Symbol	Minimum	Normal	Maximum	Units
Output	-	-37	0	8	dBm
Modulation 20dB bandwidth	-	-	1000	-	KHz

4. Pin assignment

4.1 pin distribution

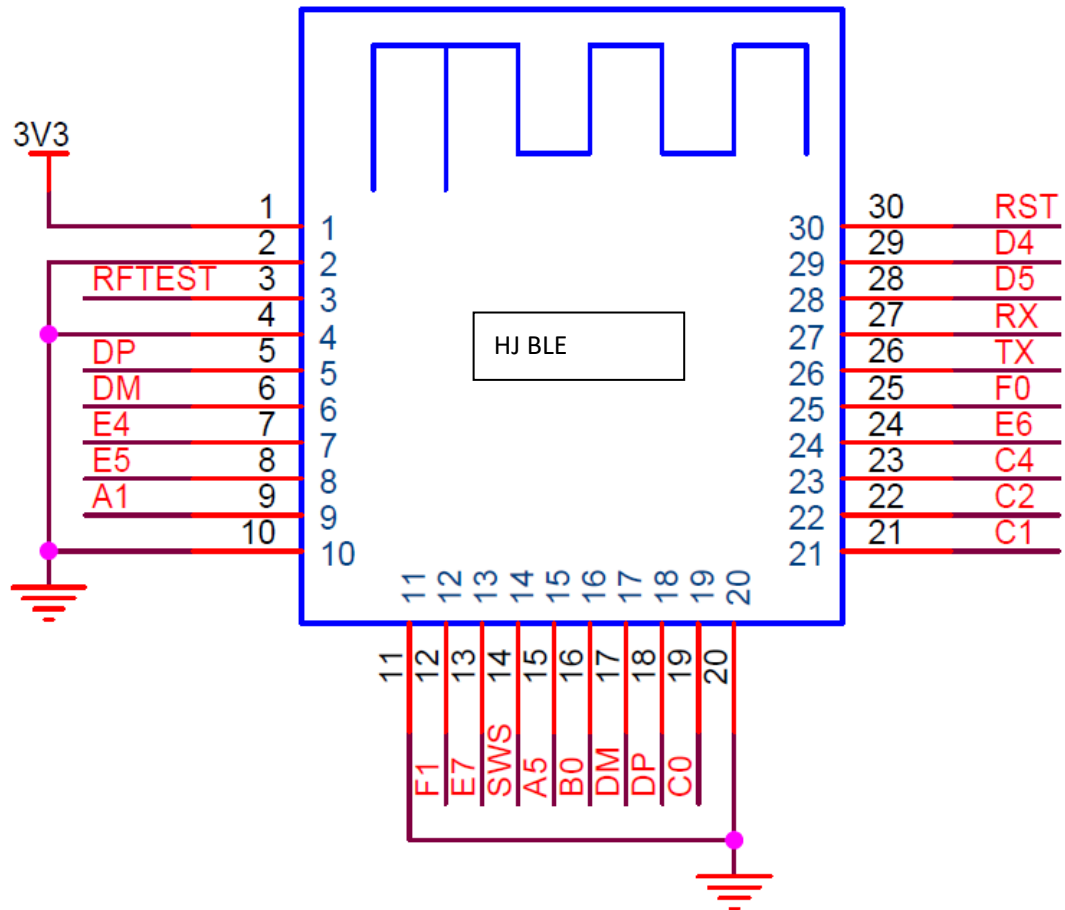

4.2 Pin definition

Table 7 .HJBLE pin definition

PIN #	引脚名	类型	描述
1	3V3	POWER	3.3V power
2、4、10、11、20	GND	POWER	grond
3	RF_TEST	ANALOG	external antenna pin
5、18	DP	I/O	USB data Positive/GPIO/ANA_B<6>
6、17	DM	I/O	USB data Minus/GPIO/ANA_B<5>
7	E4	I/O	GPIO16/ANA_E<4>
8	E5	I/O	GPIO17/ANA_E<5>
9	A1	I/O	PWM3 output/GPIO/ ANA_A<1>
12	F1	I/O	SPI clock/I2C_SCK/GPIO/ ANA_F<1>
13	E7	I/O	SPI data input/I2C_SDA/GPIO/ ANA_E<7>
14	SWS	I/O	Single wire slave/GPIO/ANA_A<0>
15	A5	I/O	PWM4 output/GPIO/ ANA_A<5>
16	B0	I/O	PWM5 output/GPIO/ ANA_B<0>
19	C0	I/O	PWM0 output/GPIO/ANA_C<0>/ Analog microphone Bias
21	C1	I/O	GPIO/PWM1 inverting output/ANA_C<1>/ Analog microphone input
22	C2	I/O	PWM1 inverting output/GPIO/ANA_C<2>
23	C4	I/O	PWM2 output/GPIO/ ANA_C<4>
24	E6	I/O	SPI chip select. Active low/ UART_RTS /GPIO/ANA_E<6>
25	F0	I/O	SPI data output/ UART_CTS /GPIO/ ANA_F<0>
26	TX	I/O	GPIO4/UART_TX/ ANA_C<6>
27	RX	I/O	GPIO5/UART_RX/ ANA_C<7>
28	D5	I/O	GPIO11/ ANA_D<5>/ (optional) 32KHz crystal output

29	D4	I/O	GPIO10/ANA_D<4>/(optional) 32KHz crystal input
30	RST	I/O	Power on reset, active low

5. Reference Design

5.1 Reference schematic

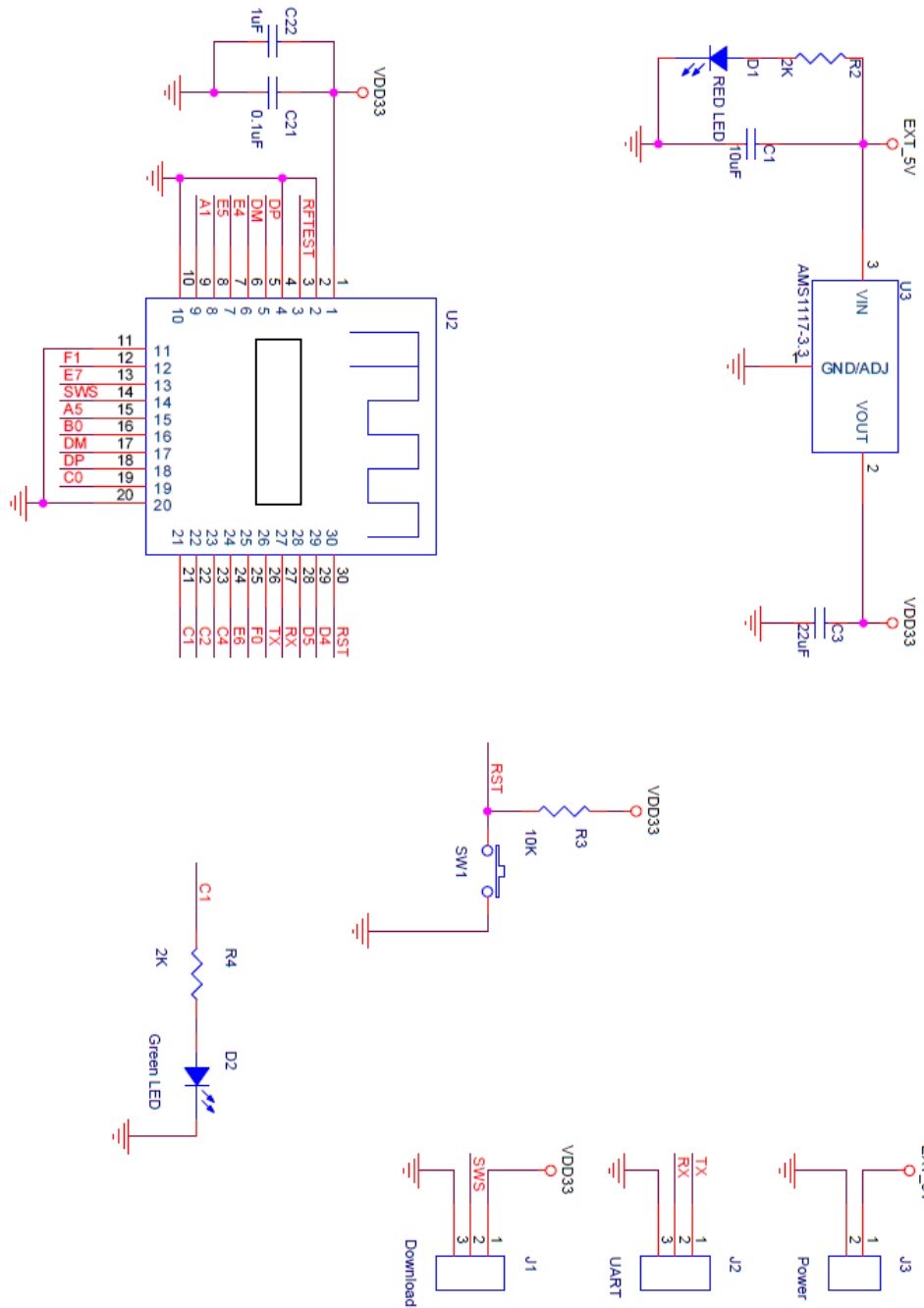

5.2 Module packet

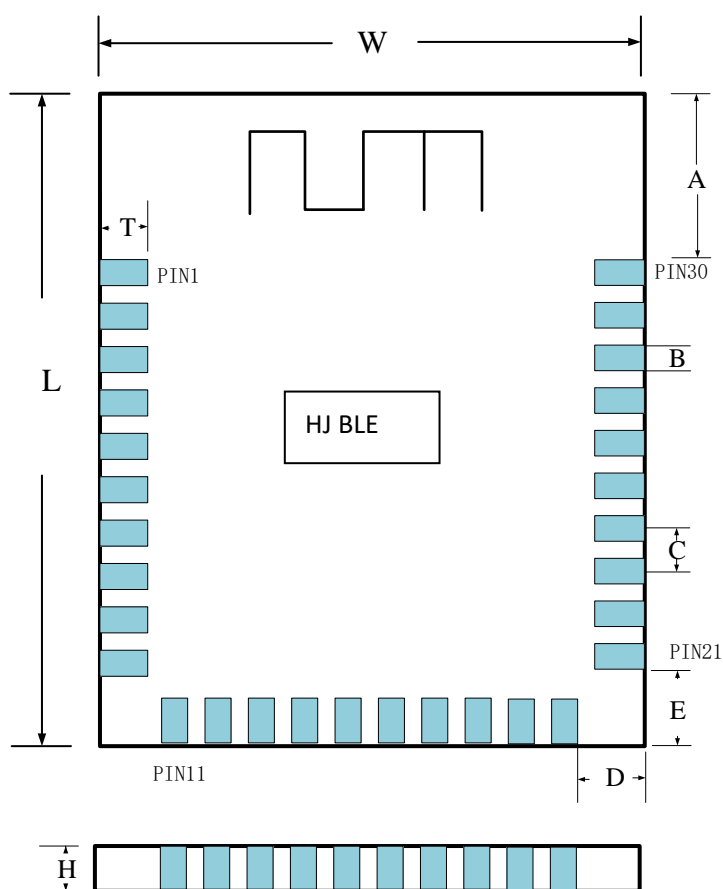

Symbol	Min.	Typ.	Max.
W	14.96	15.00	15.04
L	16.96	17.00	17.04
T	0.73	0.75	0.77
A	4.55	4.60	4.65
B	-	0.80	-
C	-	1.10	-
D	2.10	2.15	2.20
E	1.65	1.7	1.75
H	1.5	1.55	1.60

5.3 Warning

This device complies with part 15 of the FCC Rules. Operation is subject to the following two conditions: (1) This device may not cause harmful interference, and (2) this device must accept any interference received, including interference that may cause undesired operation.

Caution: Changes or modifications to this unit not expressly approved by the party responsible for compliance could void the user's authority to operate the equipment.

NOTE: This equipment has been tested and found to comply with the limits for a Class B digital device, pursuant to part 15 of the FCC Rules. These limits are designed to provide reasonable protection against harmful interference in a residential installation. This equipment generates, uses and can radiate radio frequency energy and, if not installed and used in accordance with the instructions, may cause harmful interference to radio communications. However, there is no guarantee that interference will not occur in a particular installation. If this equipment does cause harmful interference to radio or television reception, which can be determined by turning the equipment off and on, the user is encouraged to try to correct the interference by one or more of the following measures:

- Reorient or relocate the receiving antenna.
- Increase the separation between the equipment and receiver.
- Connect the equipment into an outlet on a circuit different from that to which the receiver is connected.
- Consult the dealer or an experienced radio/TV technician for help.

Information for the OEM Integrators

This device is intended for OEM integrators only. Please see the full grant of equipment document for restrictions.

Label Information to the End User by the OEM Integrators

If this certified module is installed inside the host device, then the outside of the host must be labeled with "Contains FCC ID: 2AJJGHJBLE".