

# M66

## GSM / GPRS Wireless Module

---

### Design Guide

Rev. 0.0.1

2011/6/10

Copyright © 2008 Qisda Corporation. All rights reserved.

This document contains proprietary technical information which is the property of Qisda Corporation and is issued in strict confidential and shall not be disclosed to others parties in whole or in parts without written permission of Qisda Corporation.

The documents contain information on a product, which is under development and is issued for customer evaluation purposes only.

Qisda may make changes to product specifications at any time, without notice.

#### **Module Business Division**

#### **Mobile Communications BU**

#### **Qisda Corporation**

18 Jihu Road, Nei-Hu, Taipei 114, Taiwan

Tel: +886-2-2799-8800

Fax: +886-2-2656-6398

<http://Qisda.com>

## History

Version	Date	Notes
VER: 0.0.1	2011/6/10	First release

## FCC Regulations:

● This device complies with part 15 of the FCC Rules. Operation is subject to the following two conditions: (1) This device may not cause harmful interference, and (2) this device must accept any interference received, including interference that may cause undesired operation.

● This device has been tested and found to comply with the limits for a Class B digital device, pursuant to Part 15 of the FCC Rules. These limits are designed to provide reasonable protection against harmful interference in a residential installation. This equipment generates, uses and can radiated radio frequency energy and, if not installed and used in accordance with the instructions, may cause harmful interference to radio communications. However, there is no guarantee that interference will not occur in a particular installation. If this equipment does cause harmful interference to radio or television reception, which can be determined by turning the equipment off and on, the user is encouraged to try to correct the interference by one or more of the following measures:

- Reorient or relocate the receiving antenna.
- Increase the separation between the equipment and receiver.
- Connect the equipment into an outlet on a circuit different from that to which the receiver is connected.
- Consult the dealer or an experienced radio/TV technician for help.

Changes or modifications not expressly approved by the party responsible for compliance could void the user's authority to operate the equipment.

### ▶ RF Exposure Information

This Modular Approval is limited to OEM installation for mobile and fixed applications only. The antenna installation and operating configurations of this transmitter, including any applicable source-based time-averaging duty factor, antenna gain and cable loss must satisfy MPE categorical Exclusion Requirements of §2.1091.

The antenna(s) used for this transmitter must be installed to provide a separation distance of at least 20 cm from all persons, must not be collocated or operating in conjunction with any other antenna or transmitter, except in accordance with FCC multi-transmitter product procedures.

The end user has no manual instructions to remove or install the device and a separate approval is required for all other operating configurations, including portable configurations with respect to 2.1093 and different antenna configurations.

Maximum antenna gain allowed for use with this device is 2 dBi.

When the module is installed in the host device, the FCC ID label must be visible through a window on the final device or it must be visible when an access panel, door or cover is easily re-moved. If not, a second label must be placed on the outside of the final device that contains the following text: “Contains FCC ID: VRSGM6601”.

**IC Regulations:**

This device complies with Industry Canada licence-exempt RSS standard(s).

Operation is subject to the following two conditions:

- (1) this device may not cause interference, and
- (2) this device must accept any interference, including interference that may cause undesired operation of the device.

Le présent appareil est conforme aux CNR d'Industrie Canada applicables aux appareils radio exempts de licence.

L'exploitation est autorisée aux deux conditions suivantes: (1) l'appareil ne doit pas produire de brouillage, et (2) l'utilisateur de l'appareil doit accepter tout brouillage radioélectrique subi, même si le brouillage est susceptible d'en

This Class B digital apparatus complies with Canadian ICES-003.

Cet appareil numérique de la classe B est conforme à la norme NMB-003 du Canada.

This Category II radio communication device complies with Industry Canada Standard RSS-310.

Ce dispositif de radiocommunication de catégorie II respecte la norme CNR-310 d'Industrie Canada.

**IMPORTANT NOTE:****IC Radiation Exposure Statement:**

This equipment complies with IC RSS-102 radiation exposure limits set forth for an uncontrolled environment. This equipment should be installed and operated with minimum distance 20cm between the radiator & your body.

Under Industry Canada regulations, this radio transmitter may only operate using an antenna of a type and maximum (or lesser) gain approved for the transmitter by Industry Canada. To reduce potential radio interference to other users, the antenna type and its gain should be so chosen that the equivalent isotropically radiated power (e.i.r.p.) is not more than that necessary for successful communication.

Conformément à la réglementation d'Industrie Canada, le présent émetteur radio peut fonctionner avec une antenne d'un type et d'un gain maximal (ou inférieur) approuvé pour l'émetteur par Industrie Canada. Dans le but de réduire les risques de brouillage radioélectrique à l'intention des autres utilisateurs, il faut choisir le type d'antenne et son gain de sorte que la puissance isotrope rayonnée équivalente (p.i.r.e.) ne dépasse pas l'intensité nécessaire à l'établissement d'une communication satisfaisante.

Labeling Requirements for the Host Device (from Section 3.2.1, RSS-Gen, Issue 3, December 2010): The host device shall be properly labeled to identify the module within the host device. The Industry Canada certification label of a module shall be clearly visible at all times when installed in the host device, otherwise the host device must be labeled to display the Industry Canada certification number of the module, preceded by the words “Contains transmitter module”, or the word “Contains”, or similar wording expressing the same meaning, as follows: Contains transmitter module IC: 8729A-GM6601

This radio transmitter (identify the device by certification number, or model number if Category II) has been approved by Industry Canada to operate with the antenna types listed below with the maximum permissible gain and required antenna impedance for each antenna type indicated. Antenna types not included in this list, having a gain greater than the maximum gain indicated for that type, are strictly prohibited for use with this device.

Conformément à la réglementation d'Industrie Canada, le présent émetteur radio peut fonctionner avec une antenne d'un type et d'un gain maximal (ou inférieur) approuvé pour l'émetteur par Industrie Canada. Dans le but de réduire les risques de brouillage radioélectrique à l'intention des autres utilisateurs, il faut choisir le type d'antenne et son gain de sorte que la puissance isotrope rayonnée équivalente (p.i.r.e.) ne dépasse pas l'intensité nécessaire à l'établissement d'une communication satisfaisante.

# Index

<b>1</b>	<b>POWER-ON / POWER-DOWN SEQUENCE .....</b>	<b>9</b>
1.1	POWER-ON SEQUENCE .....	9
1.2	SWITCHED ON .....	10
1.3	M66 RESTARTS.....	10
1.4	M66 SWITCH OFF.....	11
<b>2</b>	<b>INITIALIZATION PROCEDURE .....</b>	<b>12</b>
<b>3</b>	<b>SHORT MESSAGE.....</b>	<b>14</b>
3.1	INITIALIZATION .....	14
3.2	SENDING A SMS .....	14
3.3	RECEIVING A SMS.....	15
<b>4</b>	<b>VOICE CALL.....</b>	<b>16</b>
4.1	INITIALIZATION .....	16
4.2	MOBILE ORIGINATED CALL (MO) .....	17
4.3	MOBILE TERMINATED CALL (MT).....	17
<b>5</b>	<b>PPP DATA CALL.....</b>	<b>18</b>
5.1	GET READY FOR PPP DATA CALL.....	18
5.2	DIALING .....	18
<b>6</b>	<b>M2M.....</b>	<b>19</b>
<b>7</b>	<b>M66 INTERFACE .....</b>	<b>20</b>
7.1	POWER.....	21
7.2	UART.....	23
7.3	AUDIO.....	25
7.3.1	<i>Microphone</i> .....	25
7.3.2	<i>Receiver/Speaker</i> .....	26
7.3.3	<i>Grounding and Layout</i> .....	27
7.4	SIM .....	28
7.4.1	ESD .....	29
7.4.1.1	<i>ESD protection diodes</i> .....	29
7.4.1.2	<i>SIM holder</i> .....	31
7.5	ANTENNA.....	32
7.6	ANTENNA STATUS DETECTION APPLICATION.....	33





## I Power-on / Power-down Sequence

The operation voltage of M66 is between 3.3 and 4.2 V (A restricted operation range is between 4.2 and 4.7 V). It is recommended to support a stable voltage in the proper range which is between 3.8 and 4V.

### I.1 Power-on sequence

1. The initial state:  
 VBAT: 0V  
 TERM\_ON: LOW
2. Power on:  
 VBAT: HIGH (recommended: 3.8V-4V)  
 TERM\_ON: HIGH
3. Switch on M66:  
 VBAT: Keep HIGH  
 TERM\_ON: Keep LOW for 50ms then pull HIGH and remains.

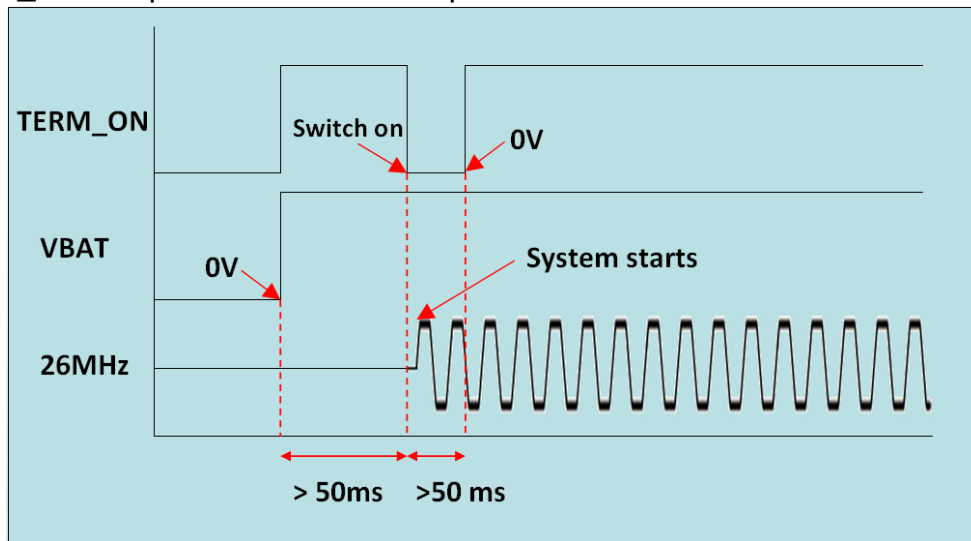

Boot-up sequence

- ※ Please note that it is recommended to wait at least 50ms to pull LOW the TERM\_ON pin after power on (Put VBAT as HIGH). The system will not start if TERM\_ON is LOW before power on.
- ※ An open-collector circuit is needed when using MPU (client) to control the TERM\_ON pin.

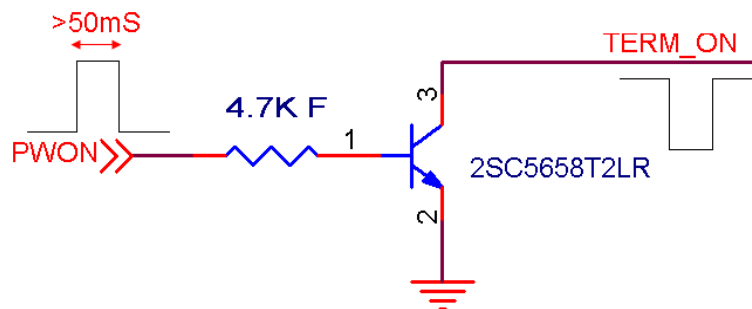

## 1.2 Switched on

The factory default baud rate of M66 is 9600. The prompt " AT-Command Interpreter ready" is output via UART1 after switched on.

LED status indication : The LPG pin (PIN 13) of M66 is used to indicate the M66/network status. The LPG outputs different kind of pattern as follows:

M66/Network status	LPG pattern(unit : sec)
M66 startup	Always High
Power saving mode (Deep sleep mode)	Always Low
No network (No SIM 、 PIN required 、 Not registered...)	High: 0.1 · Low: 0.9
Registered and idle	High: 0.1 · Low: 2.9
Connected(MO/MT Call)	Always High
GPRS transmitting/receiving data	Blinking <sup>(Note1)</sup>

Note 1 : While in data mode, the LPG pattern is blinking if data is transmitting or receiving. And the LPG keeps LOW if there is no data transmitting/receiving.

## 1.3 M66 restarts

1. General restart procedure :

- a. AT+CFUN=0, stop all network-related action.
- b. AT%RST to restart M66.

2. Emergency restart procedure :

- a. In case there is no response of any AT commands.
- b. Pull EMERG\_OFF low for 50ms and then pull high.
- c. Proceed the startup procedure(Please refer to 1.1)

## 1.4 M66 switch off

### 1. SW switch off procedure :

- a. AT+CFUN=0, stop all network-related action.
- b. AT%MSO, switch off M66.
- c. Remove VBAT.

### 2. HW switch off procedure :

- a. AT+CFUN=0, stop all network-related action.
- b. Pull TERM\_ON low for 50ms and then pull high to shutdown M66.
- c. Remove VBAT.

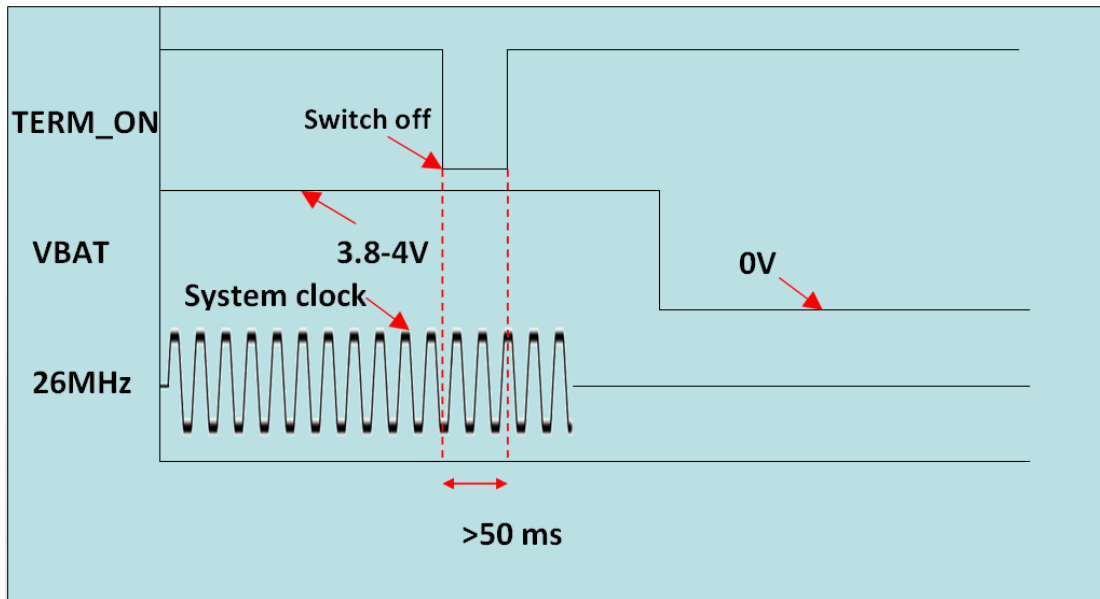

## 2 Initialization procedure

In this chapter, it describes the initialization procedure when using M66.

A suggested procedure and description of initialization.

AT OK	To check UART1 works normally. The factory default baud rate is 9600 without HW flow control. The 3-wired UART is also supported, M66 internally pull low CTS.
ATE0 OK	Echo off.
AT%TSIM %TSIM I  OK	To check SIM existence. I: SIM exist, 0: No SIM
AT+CPIN? +CPIN: READY OK	To check SIM and PIN I READY: PIN I passed
AT+CSQ +CSQ: 28,99 OK	To check the RSSI value. <rssi> value: 0~31, 99 means no network.
AT+CREG=1 OK	To enable network registration unsolicited result code.
AT+COPS? +COPS: 0,0,"CHINA MOBILE" OK	To query the network "CHINA MOBILE" is registered.
AT+CGATT ? +CGATT: 1 OK	To check GPRS attached or detached GPRS attached.

AT+GMI Qisda OK	To query the manufacturer ID.
AT+CGMR HW REVISION: S02 SW REVISION: 0.01 BUILD DATE: 2011/01/05 BUILD TIME: 16:05  OK	To query the SW/HW revision. HW information SW information SW revision building date SW revision building time
AT+GSN 358688000000XXX  OK	To query the product serial number ID.
AT+CIMI 466018770553XXX  OK	To query the international mobile subscriber ID.

### 3 Short Message

There are two formats of SMS which are PDU (Protocol Data Unit) and Text. The format could be selected by AT command. The default format is PDU and it is still recommended to select the mode during initialization.

#### 3.1 Initialization

The suggested SMS initialization procedure and description

AT+CMGF=1 OK	To select the text format. (Text format for example)
AT+CSCA? +CSCA: "+886935074443",145 OK	To query the Service Center Address In general, this information is stored in SIM. If not, please contact the operator for more information. The SMS is normally executed only if the service center address is set correctly.
AT+CPMS="SM","SM","SM" +CPMS: 3, 15, 3, 15, 3, 15 OK	To select memory storages.
AT+CPMS? +CPMS: "SM", 3, 15, "SM", 3, 15, "SM", 3, 15 OK	To query memory storages and remaining space. It must have enough space when using SMS. Please erase the messages if it is full.

#### 3.2 Sending a SMS

The suggested procedure of sending message and its description

AT+CMGS="12345678900" >Test message +CMGS: 99 OK	To send a message. The number is between quotation marks. To text the content and finished with ctrl-z for sending. Sending successfully indication +CMGS: <value>.
---	--

### 3.3 Receiving a SMS

The suggested procedure of receiving message and its description

AT+CNMI=2,1 OK	To set New Message Indication. There will be no indication if NMI does not set.
+CMTI:"SM",1	A new message is stored in SIM.
AT+CMGR=1 +CMGR:"REC UNREAD","886960530355","", "2011/01/05 20:23:44+32" tset	To read the 1 <sup>st</sup> message stored in SIM. The information of the message.
OK	
AT+CMGD=1 OK	To delete the 1 <sup>st</sup> message.
AT+CMGD=1,4 OK	To delete all messages.

## 4 Voice Call

The acoustic is highly related to the HW design especially the tooling. Please contact us for acoustic tuning if needed. And please provide the equipment(s), we will arrange it and provide the final acoustic parameters.

The tuning has its limitation, not all equipments could reach the best quality. The schematics or tooling may need to be modified. Please also provide the schematics about the audio part.

Each product is identical and unique. Please do not use the same parameters on different products.

### 4.1 Initialization

The basic initialization procedure and its description

AT%NFI? %NFI: 0,-6,0  OK	To query the current audio input path.
at%NFO? %NFO: 0,6,0  OK	To query the current audio output path.
AT%SNFS=1 OK	To select the 2 <sup>nd</sup> audio path.
AT%VLB=1 OK	To enable the echo suppression.
AT%STN=-26 OK	To set the sidetone gain to mute.

The basic procedure is only tuning gain and path. Please contact us for a better quality if distortion, noise, echo... happens to your products.



## 4.2 Mobile Originated call (MO)

Outgoing call (MO)	
ATD10086; OK	To make an MO call. The number is 10086. Please ended with a semicolon in voice call.
ATH OK	To disconnect the call.
NO CARRIER	The call is disconnected by remote party.

## 4.3 Mobile Terminated call (MT)

Incoming call (MT)	
AT+CLIP=1 OK	To enable a called subscriber to get the calling line identity of the calling party when receiving a MT call.
RING	Incoming call indication.
+CLIP: "1234567",129,"",0,"",0 RING	The information of the incoming call. The caller ID is 1234567.
+CLIP: "1234567",129,"",0,"",0	(Notify every 3 seconds by default.)
ATA OK	To Answer the call.
ATH OK	To disconnect the call.
NO CARRIER	The remote side disconnect the call.

## 5 PPP Data Call

### 5.1 Get ready for PPP data call

#### Initialization of PPP data call

AT+COPS? +COPS: 0,0,"CHINA MOBILE"  OK	To make sure that a registered network is available.
AT+CSQ +CSQ: <rsqi>,<ber> OK	To check the signal strength (rsqi). The maximum number for rsqi is 31.
AT+CGATT? +CGATT:1  OK	To make sure that GPRS is enabled.
AT+CGDCONT=1,"IP","CMNET" OK	To register to CMNET of CHINA MOBILE.

### 5.2 Dialing

To execute ATD\*99# with PPP tool.

**6 M2M**

**TBD**

## 7 M66 Interface

M66 50-pin connector interface:

PIN Name	PIN No.	I/O/P	Description
SIM_CLK	1	Output	SIM clock
SIM_VCC	2	Power	SIM power
SIM_IO	3	Input/Output	SIM input/output
SIM_RST	4	Output	SIM reset
SIM_DET	5	Output	SIM detect
SIM_GND	6		SIM ground
NC	7		
GND	8		Ground
USB_DM	9	Input/Output	USB DM
USB_DP	10	Input/Output	USB DP
NC	11		
NC	12		
LPG	13	Output	LED paging indicator
ANT_EMG	14	Output	Emergency indication for antenna detection
RXD	15	Output	UART1 RXD
Ant_Dect_EN	16	Input	Interrupt for 36V applied on the antenna signal line
TXD	17	Input	UART1 TXD
VDD-RTC	18	Power	RTC backup battery connection pad
RXD2	19	Output	UART2 RXD
TXD2	20	Input	UART2 TXD
GND	21		Ground
GND	22		
GND	23		
GND	24		
GND	25		
VBAT	26	Power	Power (recommend 3.8V~4.0V)
VBAT	27		
VBAT	28		
VBAT	29		
VBAT	30		
VDD-IO	31	Power	UART1 power supply
RING	32	Output	UART1 RING indicator
NC	33	Output	UART1 DSR
RTS	34	Input	UART1 RTS
NC	35	Input	UART1 DTR
NC	36		
CTS	37	Output	UART1 CTS
Ant_Dect_ADC	38	Input	
DCD	39	Output	UART1 DCD
EMERG_OFF	40	Input	Hardware power off
TERM_ON	41	Input	Power On
GND	42		Ground
MIC2	43	Input	Hands-free MIC input
MICBIAS	44	Output	Hands-free MIC bias
MIC1-P	45	Input	MIC positive input(+)
MIC1-N	46	Input	MIC negative input(-)
SPK-N	47	Output	Hands-free speaker negative output (-)
SPK-P	48	Output	Hands-free speaker positive output (+)
EAR-P	49	Output	Handheld earpiece positive output (+)
EAR-N	50	Output	Handheld earpiece negative output (-)

7.1 Power

The operating voltage of M66 is between 3.3V and 4.7V. Please make sure that the supply voltage is still in the proper range when a maximum current is drawn from the power supply when a maximum RF output power is required.

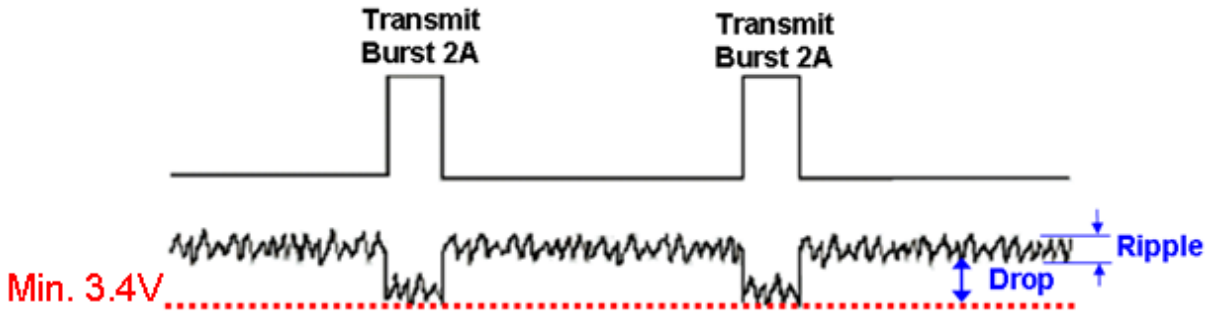

Please note that once the supply voltage to M66 drops below 3.3V, module would be shut down. If a power supply regulator is used for VBAT (power supply to M66), please make sure the maximum output current rating should be more than 2A which is the minimum requirement for a maximum RF output power. A reference design for a switching power supply is shown below. The voltage rating of C31 and C35 should be raised higher if Vin is greater than 12V. LM2676S-ADJ (or LM2673S-ADJ) can be used as the switching regulator in the reference design.

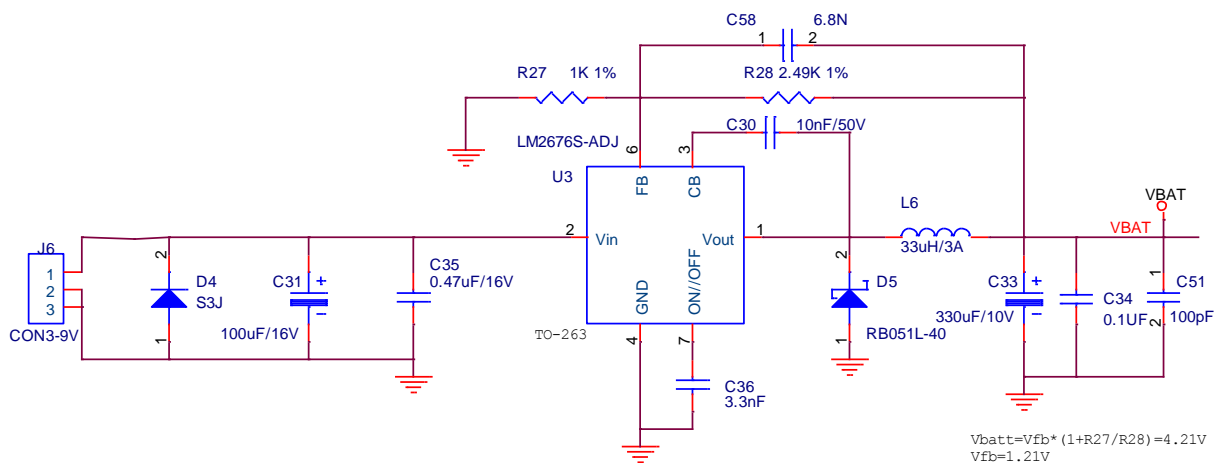

A large capacitor with low ESR or parallel capacitors can be used to compensate the insufficient supply current provided by the power regulator. The required capacitance can be calculated from the following equations.

$$C = Q/U = (\Delta I \times \Delta t) / (\Delta U)$$

$$C = (0.8A) \times 577 \mu s / 250mV = 1846 \mu F$$

C = Capacitance in  $\mu F$

$\Delta t$  = GSM time slot (577  $\mu s$ )

Q = Electricity charger

$\Delta U$  = Voltage drop

$\Delta I$  = Compensation in current (the required current – the supplied current)

During power layout design, there are 2 reminders

**A. Width**

**A.1** VBAT width: at least 80mil.

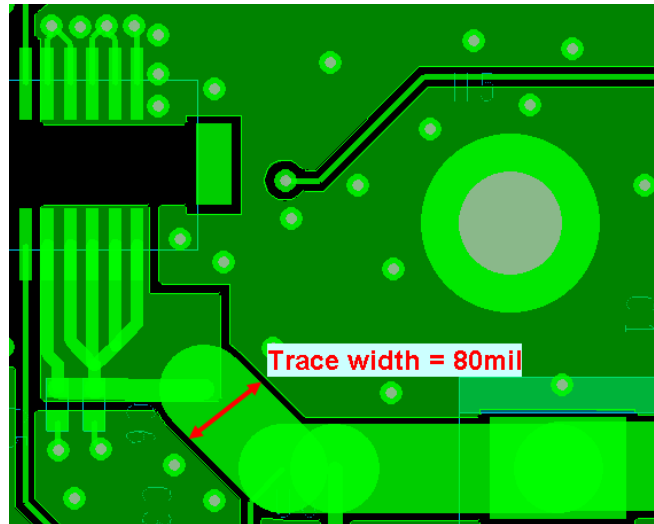

**B.** Recommend to have at least 7 via holes if VBAT needs to go through different layers to have a minimum resistance.

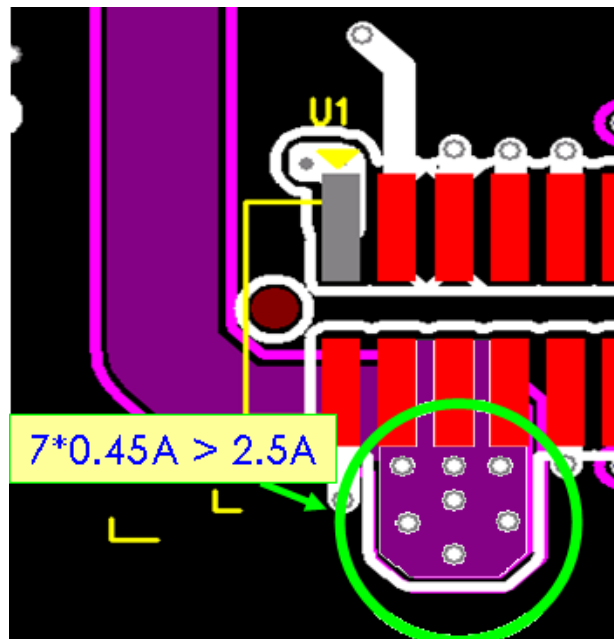

## 7.2 UART

The serial interface UART1 supports 6-wired, 4-wired, or 2-wired interface. M66 communicates with an external MPU via UART1. The factory default baud rate of UART1 is 9600 and it supports auto baud rate.

The main function of UART2 is for debug. It communicates with PC via UART transceiver.

M66 serves as a DCE and the UART pin definition is as the following table.

RS232 pin	Name	Direction	M66 pin name	M66 pin no.
3	Transmit Data (TXD)	DTE → M66	TXD	17
2	Receive Data (RXD)	DTE ← M66	RXD	15
7	Request To Send (RTS)	DTE → M66	RTS	34
8	Clear To Send (CTS)	DTE ← M66	CTS	37
1	Data Carrier Detect (DCD)	DTE ← M66	DCD	39
9	Ring Indicator (RI)	DTE ← M66	RI	32

It is recommended to use 3V interface.

### For 3V UART Interface

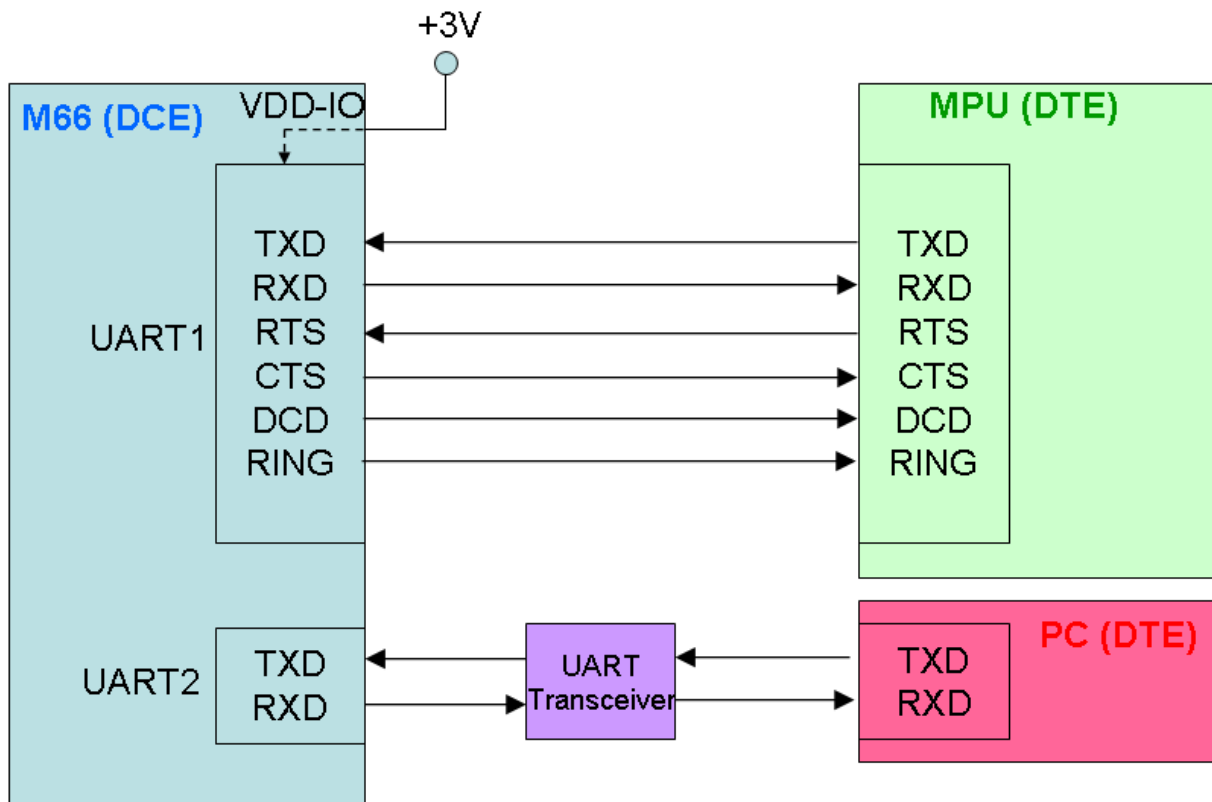

A level shift circuit should be added to the system if the UART interface of host side is not 3V. The following is an example of 5V interface.

**For 5V UART Interface**

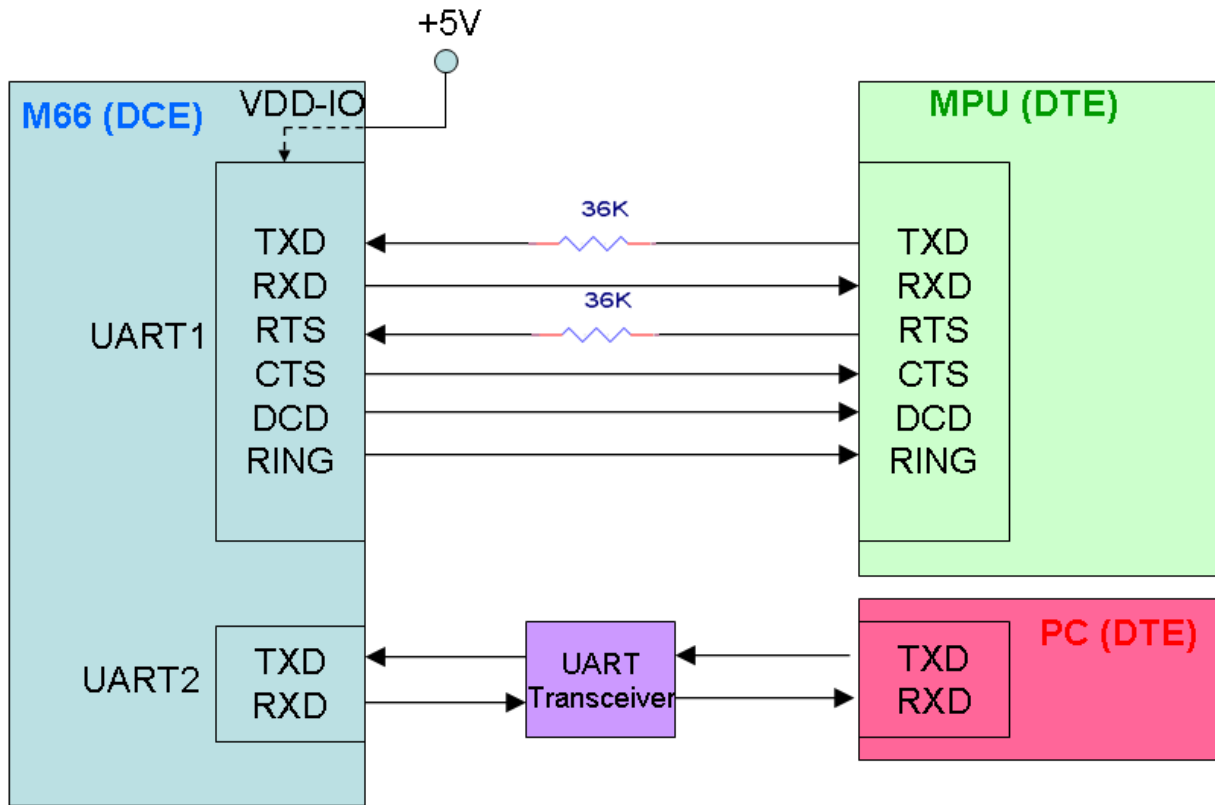



### 7.3 Audio

It divides into 2 parts, microphone (uplink) and receiver/speaker (downlink).

#### 7.3.1 Microphone

Microphone schematics design is shown below for reference:

( MICIP-MICIN )		Unit
Maximum input range	0.2	V <sub>rms</sub>
Differential input resistance	20	kΩ
DC level at MICBIAS	1.9	V

#### Valid MIC specifications

- Load Impedance  $\leq 2.2\text{K}\Omega$
- Freq. Response : 20 – 16KHz
- Standard operation voltage: 1.9V
- Sensitivity: -44+3dB(1KHz)
- SN ratio:  $\geq 58\text{dB}$

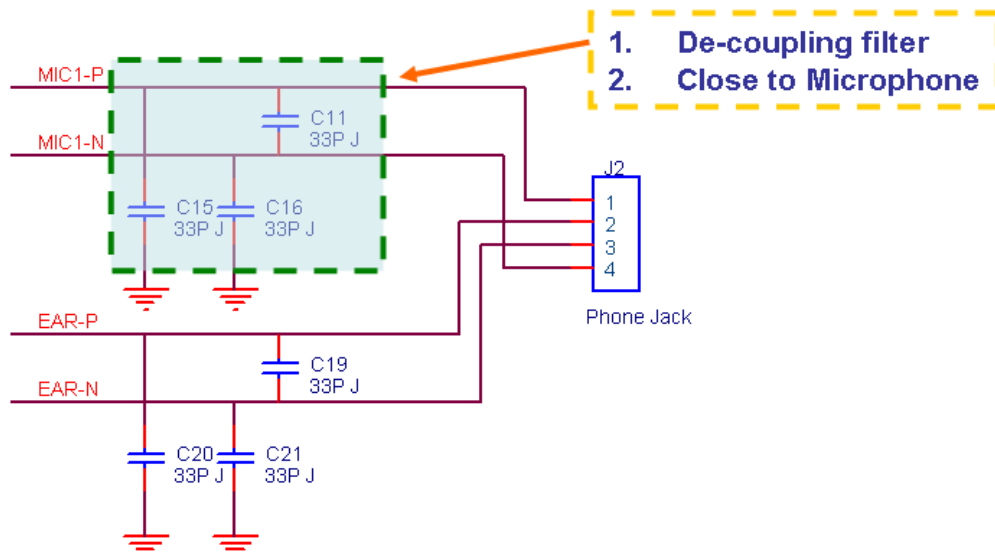

1. Please use the differential circuit design.
2. The microphone signal traces should be as short as possible.
3. Add decoupling circuits for external microphone bias and audio power supply to reduce TDD noise.
4. Audio traces should be kept away from the VBATT and high speed clock traces.
5. Good shielding for audio path including components and traces. If possible, use via holes to connect the ground shielding above and beneath the audio signals.
6. Twisted pair for external microphone lines. No necessary to use copper foil to wrap around external microphone lines.
7. The distance between microphone and antenna should be at least 10 cm.
8. Add the small capacitor (33pF) across the microphone input traces to suppress the noise.

### 7.3.2 Receiver/Speaker

Receiver/speaker schematics design is shown below for reference:

EARN – EARP		Unit
Maximum output swing	0.6	Vrms
Rating current	50	mA
Differential Minimum resistance (R)	28	$\Omega$

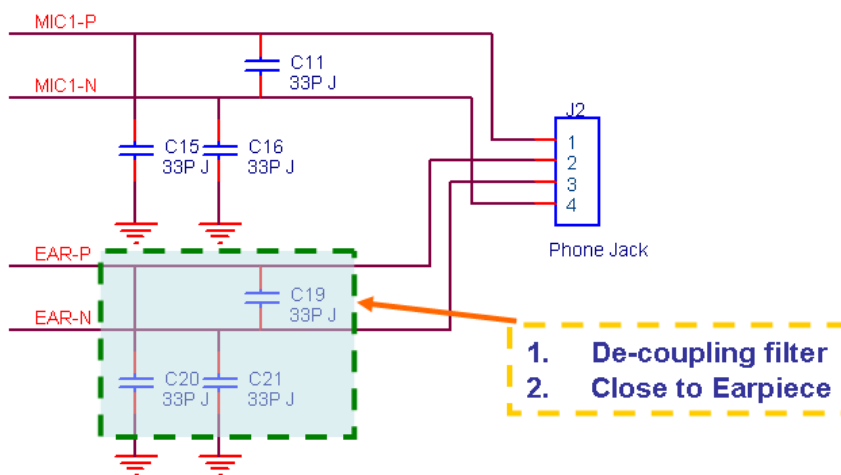

As to the Hands-free application, it is suggested to use MIC2/MICBIAS and SPK-P/SPK-N to get a better audio performance. SPK-P/SPK-N could drive a  $8\Omega$  speaker directly without an external audio amplifier and the output power is 500 mW.

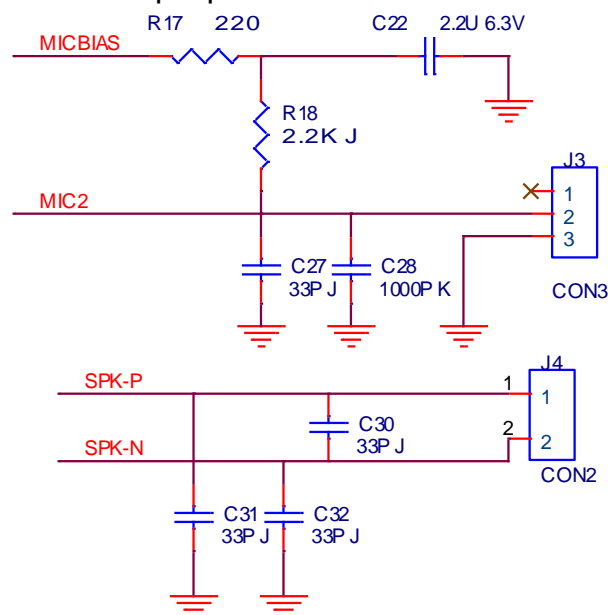

### 7.3.3 Grounding and Layout

Good grounding and conductive screws/screw holes are important to the audio quality and performance. Please take special attention to the PCB layout of the screw holes and the surrounding ring area. They should be copper plated and electrically conductive.

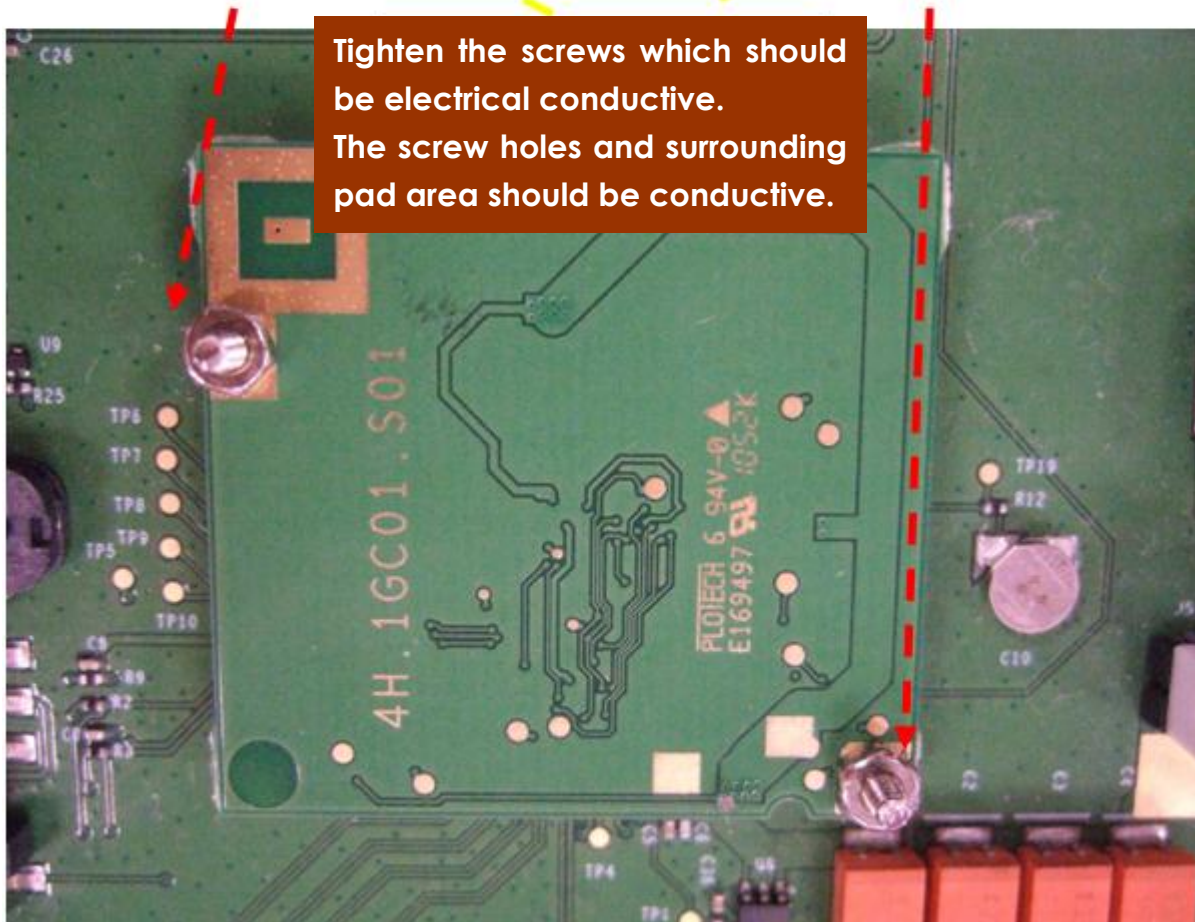
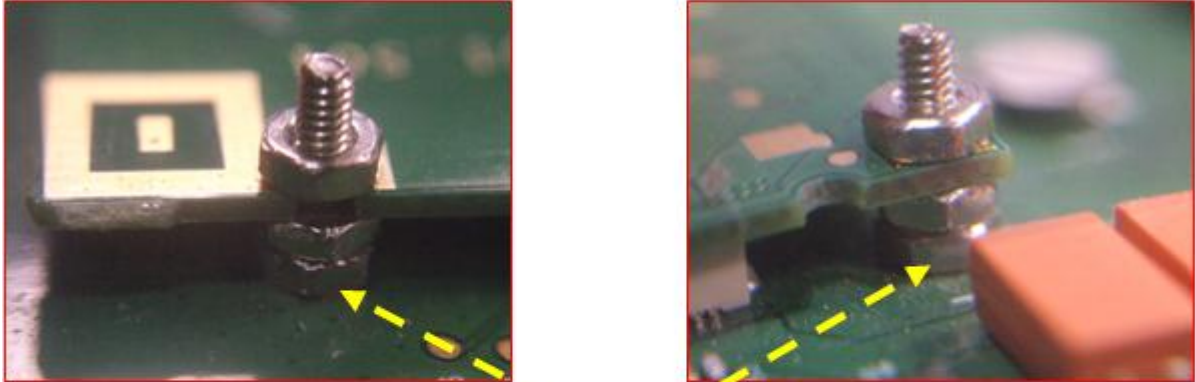

Recommended audio trace layout is illustrated in the following diagram.

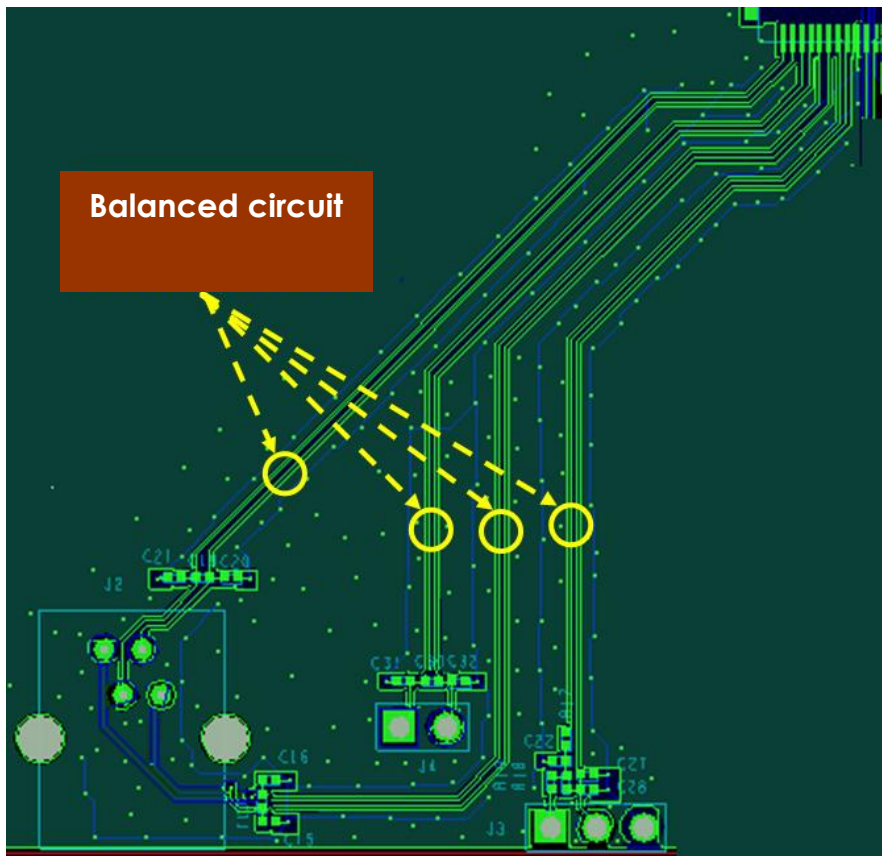

### 7.4 SIM

The Vpp pin (Programming Voltage) is no function in current plug-in SIM. Please leave it opened. The reference circuit is depicted below.

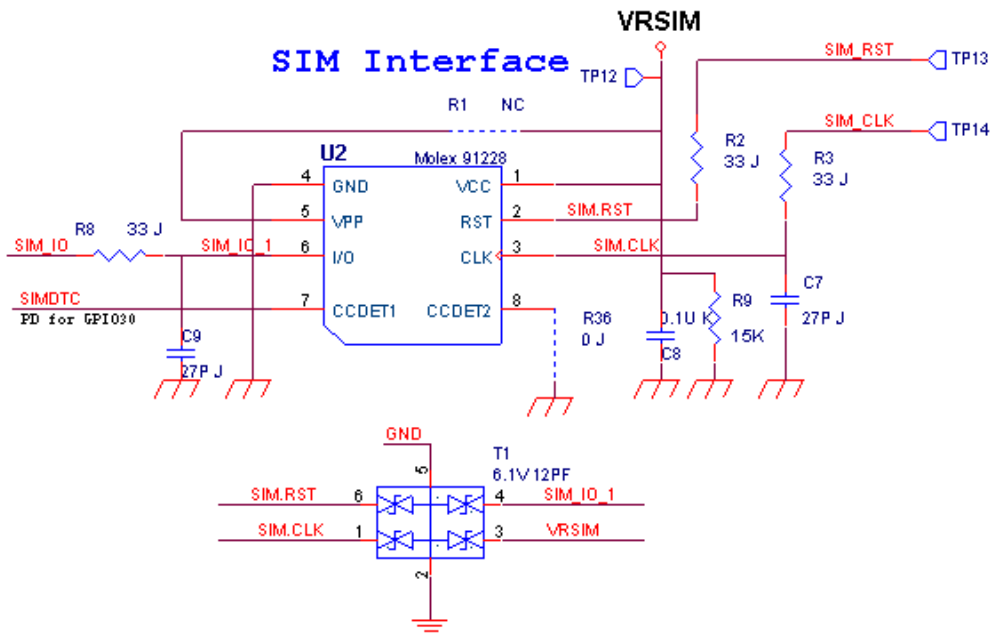

7.4.1 ESD

7.4.1.1 ESD protection diodes

An ESD protection circuit could prevent the SIM cards from being damaged by ESD. Please add an ESD circuit close to the CIM circuit to prevent ESD damaged. It is suggested to use the following EDS protection diode.

ELECTRICAL CHARACTERISTICS (T<sub>amb</sub> = 25°C)

Symbol	Parameter
V <sub>RM</sub>	Stand-off voltage
V <sub>BR</sub>	Breakdown voltage
V <sub>CL</sub>	Clamping voltage
I <sub>RM</sub>	Leakage current
I <sub>PP</sub>	Peak pulse current
αT	Voltage temperature coefficient
V <sub>F</sub>	Forward voltage drop
C	Capacitance
R <sub>d</sub>	Dynamic resistance

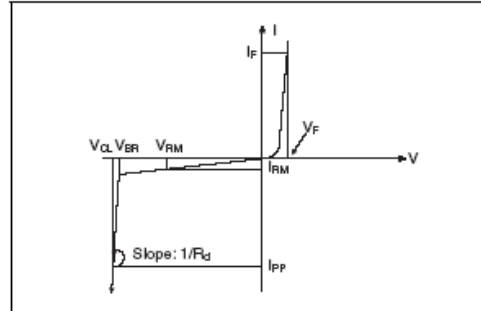

Part Number	V <sub>BR</sub>		@ I <sub>R</sub>	I <sub>RM</sub>	@ V <sub>RM</sub>	R <sub>d</sub>	αT	C
	min.	max.		max.		typ.	max.	typ. @ 0V
	V	V	mA	μA	V	Ω	10 <sup>-4</sup> /°C	pF
ESDALC6V1P6	6.1	7.2	1	0.5	3	1.5	4.5	12

Electrical characteristics of the ESD protection diodes are shown as below for reference.



## ESDALC6V1P6

ASD™

### QUAD LOW CAPACITANCE TRANSIL™ ARRAY FOR ESD PROTECTION

#### MAIN APPLICATIONS

Where transient overvoltage protection in ESD sensitive equipment is required, such as :

- Computers
- Printers
- Communication systems and cellular phones
- Video equipment

This device is particularly adapted to the protection of symmetrical signals.

#### FEATURES

- 4 Unidirectional Transil™ functions
- Breakdown voltage  $V_{BR} = 6.1 \text{ V min.}$
- Low diode capacitance (12pF @ 0V)
- Low leakage current < 500 nA
- Very small PCB area < 2.6 mm<sup>2</sup>

#### DESCRIPTION

The ESDALC6V1P6 is a monolithic array designed to protect up to 4 lines against ESD transients.

The device is ideal for situations where board space saving is required.

#### BENEFITS

- High ESD protection level
- High integration
- Suitable for high density boards

#### COMPLIES WITH THE FOLLOWING STANDARDS:

- IEC61000-4-2 level 4:
  - 15kV (air discharge)
  - 8kV (contact discharge)
- MIL STD 883E-Method 3015-7: class3
  - 25kV HBM (Human Body Model)

#### Order Codes

Part Number	Marking
ESDALC6V1P6	D



#### FUNCTIONAL DIAGRAM

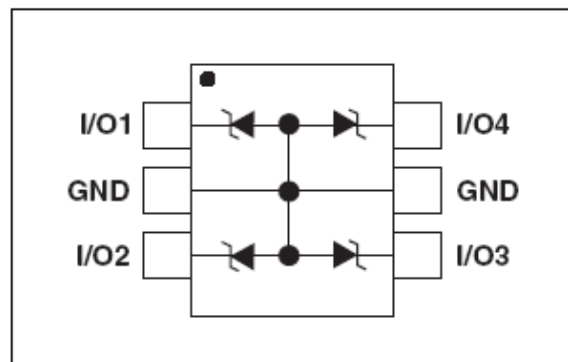

**Recommended ESD protection components from different vendors:**

- SESMF05C
- SENZQA5V6AV5
- SEDF6A6V8
- AMOTECH
  - AVSC 5S 04F 025

**7.4.1.2 SIM holder**

Besides ESD protection, the placement and layout of the SIM holder is also important to SIM protection.

1. The ESD protection unit should be placed close to the SIM holder.
2. The ground pin of ESD protection unit should be directly connected to main ground. It will make the ESD energy discharged to ground plane.
3. The trace width should be at least 0.3mm between SIM holder and ESD protection unit.
4. The ESD protection unit should be between SIM holder and M66.
5. The trace between ESD protection unit and M66 should be in a different layer and the width should be at least 0.1mm.

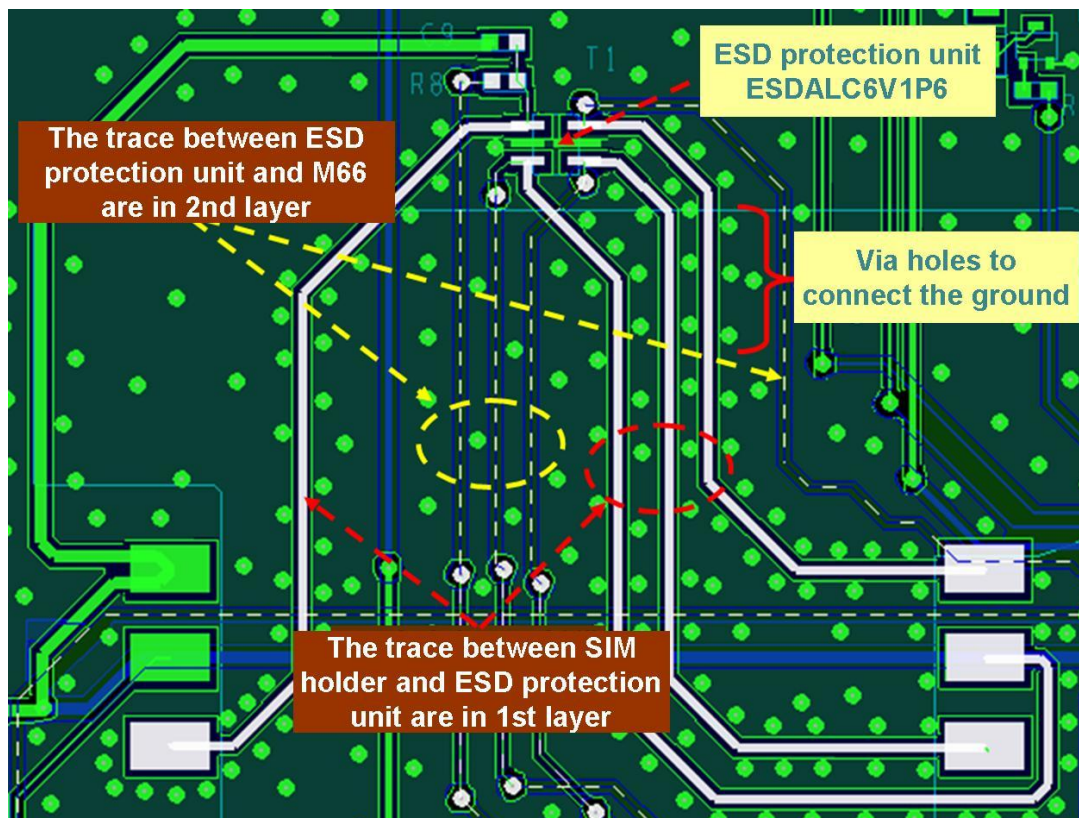

## 7.5 Antenna

M66 has an antenna pad on the BOTTOM side. It is possible to solder the coaxial cable directly. The impedance of the cable should be 50 ohm ( $\pm 10\%$ )

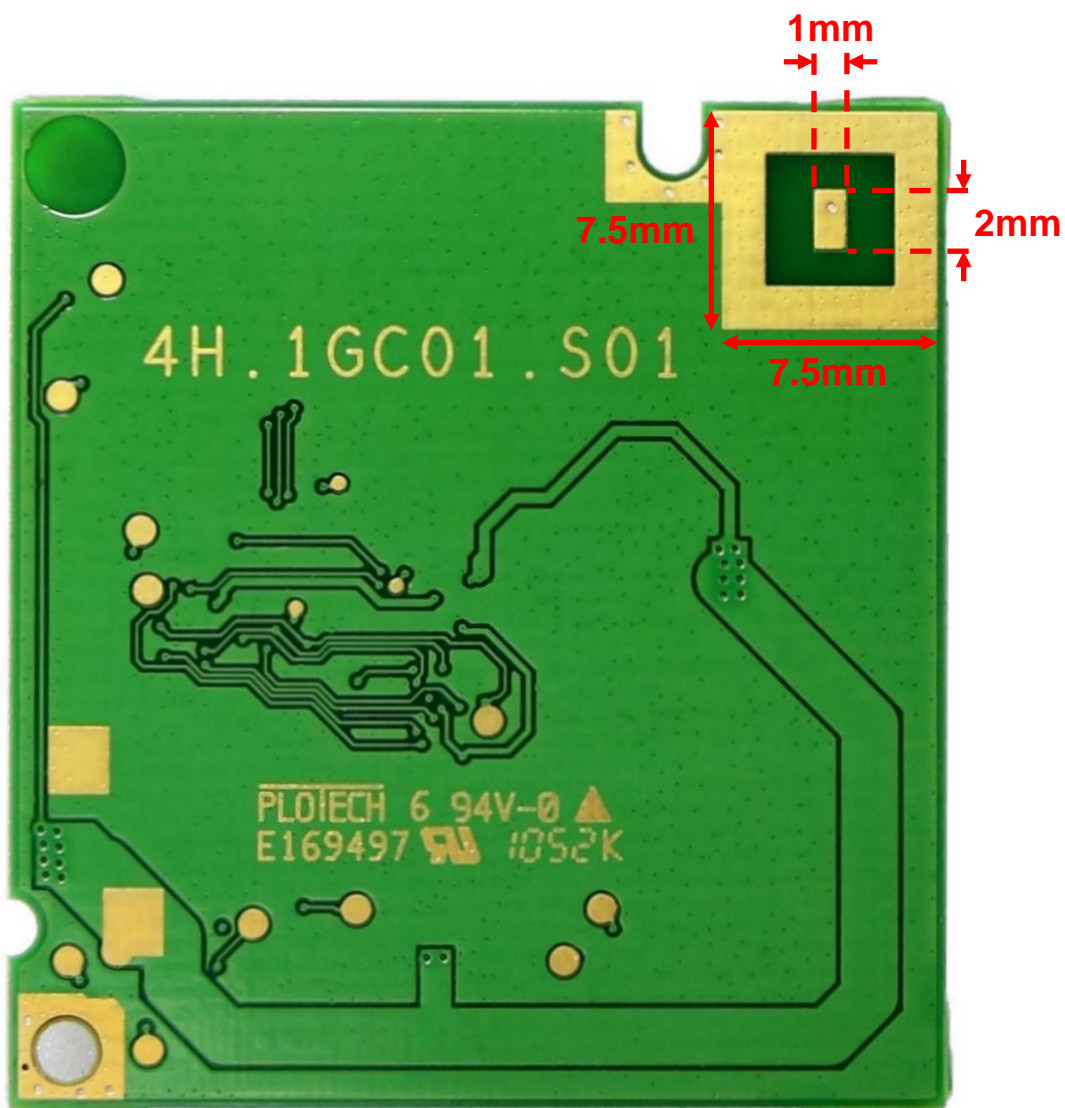

M66 antenna pad



### 7.6 Antenna status detection application

Being able to detect and diagnose the antenna is a valuable feature for many system integrators, and especially for automotive applications. The ability to detect whether the antenna is connected to the communication appliance is useful for diagnosing installation or production problems as well as any tampering with the system. Users can detect the connection status by AT command. The responses are three kinds of status:

1. Antenna is connected to the RF cable properly.
2. The signal line of antenna is disconnected from RF Cable.
3. The signal line of antenna is connected to GND by accident.

If the signal line of antenna is short circuited to the +36V Power line ,(Ex. The battery in automobile), M66 will inform MPU of emergency status by ANT\_EMG pin.

Application Reference Circuitry is shown below. The following assumes that the application is using a commonly found 10KΩ DC terminated antenna. The green bold line is micro-strip line with 50Ω characteristic impedance. PAD1 is the RF connector for Antenna.

