

# W50

## WLAN / Bluetooth Wireless Module

---

Rev. 1.0.0

2011/10/20

Copyright © 2010 Qisda Corporation. All rights reserved.

This document contains proprietary technical information which is the property of Qisda Corporation and is issued in strict confidential and shall not be disclosed to others parties in whole or in parts without written permission of Qisda Corporation.

The documents contain information on a product, which is under development and is issued for customer evaluation purposes only.

Qisda may make changes to product specifications at any time, without notice.

### **Wireless Data Application BD**

**Mobile Communications BU**

**Qisda Corporation**

18 Jihu Road, Nei-Hu, Taipei 114, Taiwan

Tel: +886-2-2799-8800

Fax: +886-2-2656-6398

<http://Qisda.com>

## Contents

<b>1.</b>	<b>REVISION HISTORY .....</b>	<b>4</b>
<b>2.</b>	<b>FUNCTIONAL DESCRIPTION .....</b>	<b>5</b>
2.1.	OVERVIEW .....	5
2.2.	PIN CONFIGURATION .....	6
2.2.1.	PIN ARRANGEMENT .....	6
2.2.2.	PIN FUNCTION .....	6
<b>3.</b>	<b>TECHNICAL DESCRIPTION.....</b>	<b>9</b>
3.1.	RADIO FEATURES .....	9
3.1.1.	RF PORT.....	9
3.1.2.	RF BLUETOOTH.....	9
3.1.3.	RF WLAN .....	9
3.1.4.	SPURIOUS EMISSIONS .....	9
3.2.	CLOCK .....	9
3.2.1.	MAIN CLOCK .....	10
3.2.2.	SLEEP CLOCK .....	10
3.3.	START UP AND RESET.....	10
3.3.1.	POWERING.....	10
3.3.2.	RESET .....	11
3.4.	ANTENNA DIAGNOSE CIRCUIT .....	12
3.5.	POWER SUPPLY.....	13
3.5.1.	MAIN POWER .....	13
3.5.2.	SUPPLY OF I/O PINS .....	14
3.5.3.	POWER DOWN MODE.....	14
<b>4.</b>	<b>ELECTRICAL SPECIFICATION.....</b>	<b>15</b>
4.1.	ABSOLUTE MAXIMUM RATINGS.....	15
4.2.	OPERATING CONDITIONS .....	15
4.2.1.	ENVIRONMENTAL CONDITIONS .....	15
4.2.2.	POWER SUPPLY.....	15
4.2.3.	DIGITAL PINS .....	16
4.2.4.	EXTERNAL SLEEP CLOCK TIMING.....	16

4.2.5.	RF PERFORMANCE .....	16
<b>5.</b>	<b>MECHANICAL SPECIFICATION.....</b>	<b>18</b>
5.1.	PACKAGE TYPE .....	18
5.2.	PACKAGE DIMENSIONS .....	18
<b>6.</b>	<b>LABELING AND ORDERING INFORMATION .....</b>	<b>20</b>
6.1.	PRODUCT LABEL .....	20
6.1.1.	SHIELDING FRAME COVER LABEL .....	20
6.1.2.	SHIELDING CASE COVER LABEL .....	20
6.2.	ORDERING INFORMATION .....	21
<b>7.</b>	<b>PRODUCT HANDLING .....</b>	<b>21</b>
7.1.	PACKAGING .....	21
7.2.	PACKING MATERIALS .....	24
7.2.1.	HUMIDITY PROTECTION MATERIALS .....	24
7.2.1.1.	ALUMINUM BAG .....	24
7.2.1.2.	HUMIDITY INDICATOR .....	25
7.2.1.3.	DESICCANT.....	26
7.2.2.	PACKING MATERIALS .....	27
7.2.2.1.	REEL.....	27
7.2.2.2.	PIZZA BOX.....	27
7.2.2.3.	CARTON .....	29
7.2.3.	LABELS .....	29
7.2.3.1.	OOB LABEL.....	29
7.2.3.2.	CARTON LABEL .....	35
7.2.3.3.	CAUTION LABEL .....	35
7.2.4.	TAPES .....	36
7.3.	SHIPMENT, STORAGE AND HANDLING .....	37
<b>8.</b>	<b>CERTIFICATIONS.....</b>	<b>37</b>
<b>8.1.</b>	<b>FCC REGULATIONS: .....</b>	<b>37</b>
<b>9.</b>	<b>CONTACT.....</b>	<b>38</b>

## 1. Revision history

Version	Date	Notes
VER: 0.0.1	2011/12/2	Preliminary version

## 2. Functional description

### 2.1. Overview

This chapter provides a short overview over the most important functions and features of the module. This data sheet is preliminary and will be changed if needed. The module is built on the Marvell® 88W8688 low-cost highly-integrated IEEE 802.11a/g/b MAC/Baseband/RF WLAN and Bluetooth Baseband/RF system-on-chip (SoC).

The module supports IEEE 802.11g payload data rates of 6, 9, 12, 18, 24, 36, 48, and 54 Mbps, as well as 802.11b data rates of 1, 2, 5.5 and 11 Mbps for WLAN operation. For Bluetooth operation, the module supports Bluetooth 3.0 + High Speed (HS) (also compliant with Bluetooth 2.1 + EDR).

For security, the 88W8688 supports the IEEE 802.11i security standard through implementation of the Advanced Encryption Standard (AES)/Counter Mode CBC-MAC Protocol (CCMP), and Wired Equivalent Privacy (WEP) with Temporal Key Integrity Protocol (TKIP) security mechanisms. The module also supports Internet Protocol Security (IPsec) with DES//3DES/AES encryption and MD5/SHA-1 authentication as well as 802.11e Quality of Service (QoS).

The module supports dual SDIO host interface for connecting the WLAN and Bluetooth to the host processor. For Bluetooth application the high-speed UART (up to 4MB/s), PCM/Inter-IC Sound (I2S), are supported too.

For better throughput of WLAN/BT, the module provides different RF paths for WLAN and Bluetooth for own antennas. By using of two antennas with enough decoupling it enables to do without coexistence.

## 2.2. Pin Configuration

### 2.2.1. Pin arrangement

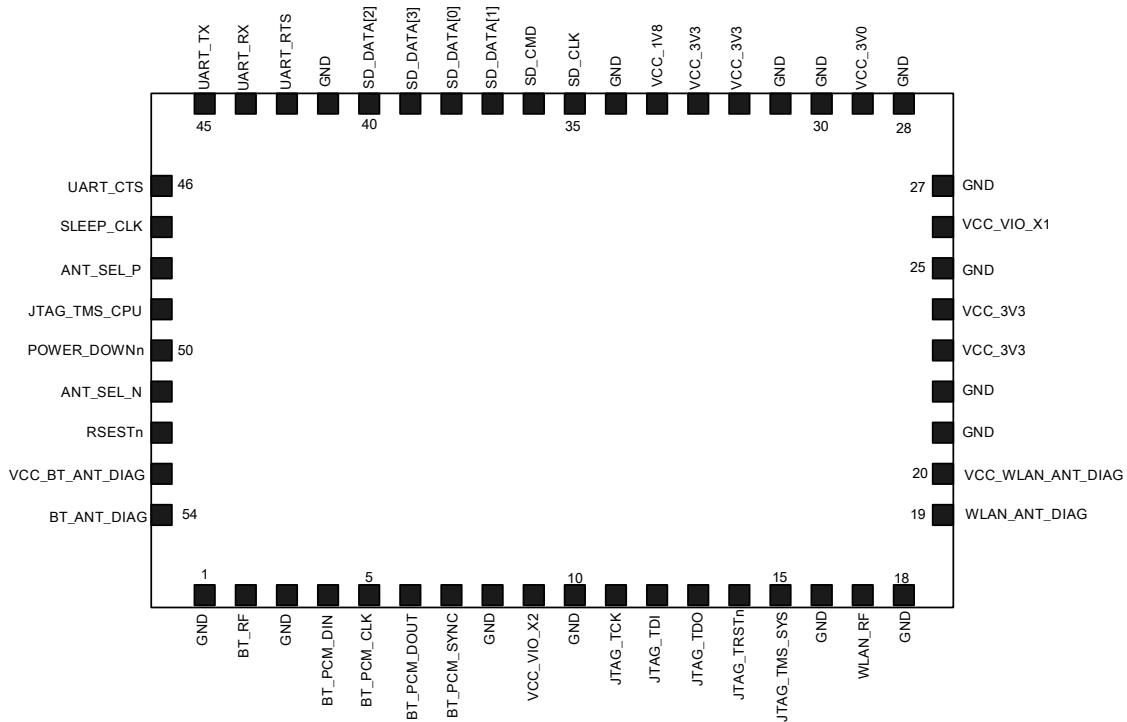

Figure 2: Pin arrangement

### 2.2.2. Pin function

Pin#	Interface	Pin Name	Type	Supply	Description
36	SDIO	SD_CLK	I	VIO_X1	SDIO Clock Input
37		SD_CMD	I/O	VIO_X1	SDIO Command
39		SD_DATA[0]	I/O	VIO_X1	SDIO Data Line Bit [0]
38		SD_DATA[1]	I/O	VIO_X1	SDIO Data Line Bit [1]
41		SD_DATA[2]	I/O	VIO_X1	SDIO Data Line Bit [2]
40		SD_DATA[3]	I/O	VIO_X1	SDIO Data Line Bit [3]
46	UART	UART CTS	I	VIO_X1	UART Clear to send
44		UART RX	I	VIO_X1	UART Receive
45		UART TX	O	VIO_X1	UART Transmit
43		UART RTS	O	VIO_X1	UART Request to send
5	PCM	BT_PCM_CLK	O	VIO_X2	Bluetooth PCM Clock (master)
7		BT_PCM_SYNC	O	VIO_X2	Bluetooth PCM Sync (master)

6		BT_PCM_DOUT	O	VIO_X2	Bluetooth PCM Data Out
4		BT_PCM_DIN	I	VIO_X2	Bluetooth PCM Data In
52	CONTROL	RESETn	I	VIO_X1	Shut down BT/WLAN IC (active low, internal 10 kOhm pull-down)
50		POWER_DOWNn	I	-	Shut down internal 1V8 LDO (active low, internal 10 kOhm pull-down)
47	CLOCK	SLEEP_CLK	I	VIO_X1	Clock Input for External Sleep Clock
11	JTAG	JTAG_TCK	I	VIO_X2	JTAG Test Clock Input
12		JTAG_TDI	I	VIO_X2	JTAG Test Data Input
13		JTAG_TDO	O	VIO_X2	JTAG Test Data Output
14		JTAG_TRSTn	I	VIO_X2	JTAG Test Reset (active low)
15		JTAG_TMS_SYS	I	VIO_X2	JTAG Test Mode Select
49		JTAG_TMS_CPU	I	VIO_X2	JTAG Test Mode Select
2	RF	BT_RF	I/O	-	Bluetooth RF, DC decoupled
17		WLAN_RF	I/O	-	WLAN RF, DC decoupled
54	Diagnose	BT_ANT_DIAG	O	VCC_BT_ANT_DIAG	Bluetooth antenna diagnose
19		WLAN_ANT_DIAG	O	VCC_WLAN_ANT_DIAG	WLAN antenna diagnose
48	Bluetooth / WLAN	ANT_SEL_P	O	-	BT/WLAN Antenna select when the antenna is shared for BT and WLAN
51	Antenna Select	ANT_SEL_N	O	-	BT/WLAN Antenna select when the antenna is shared for BT and WLAN
<b>Power</b>					
23,24		VCC_3V3	I	-	Positive supply for WLAN PA
32,33		VCC_3V3	I	-	Positive supply for 1V8, 3V0 voltage regulators
26		VCC_VIO_X1	I	-	VIO_X1 supply domain. Positive supply for SDIO, UART interfaces as well as RESET and SLEEP_CLOCK pads
9		VCC_VIO_X2	I	-	VIO_X2 supply domain. Positive supply for PCM and JTAG interfaces pads as well as internal E2PROM
29		VCC_3V0	O	-	internal 3V0 voltage regulator, for test purpose, leave unconnected

34		VCC_1V8	O	-	internal 1V8 voltage regulator, for test purpose, leave unconnected
53		VCC_BT_ANT_DIAG	I	-	Supply for BT antenna diagnose circuit
20		VCC_WLAN_ANT_DIAG	I	-	Supply for WLAN antenna diagnose circuit
1,3,8, 10,16, 18,21, 22,25, 27,28, 30,31, 35,42		GND	-	-	Ground

\*) The antenna diagnose functionality is supported only when antenna has a DC path with 51K Ohm resistance to ground.



## 3. Technical Description

### 3.1. Radio Features

#### 3.1.1. RF port

For WLAN and Bluetooth, the module provides single ended, 50 ohm matched bi-directional ports. The RX / TX switches are incorporated either in module or in 88W8688 chip.

#### 3.1.2. RF Bluetooth

The RF part of Bluetooth has a balun for transforming the differential RF port of 88W8688 to single ended port of module. The balun is also used for powering internal PA / LNA with 1, 8V supply.

The output power of 2 dBm with power control is fully compliant to BT Class II requirements.

The RF modem supports GFSK and DPSK modulations according to Bluetooth 2.1+EDR standard.

#### 3.1.3. RF WLAN

The module supports 802.11g/b operation in word harmonized 2.4 GHz ISM band. The Power Amplifier, RX balun and TX/RX switch are integrated in to module. The output power is 15 +/- 1 dBm in automotive temperature range.

#### 3.1.4. Spurious emissions

Both the spurious emission of conducted and radiated had compliant with the standards EN 300328, FCC Part 15.247.

### 3.2. Clock

### 3.2.1. Main clock

The local oscillator and digital clocks are generated from crystal. The crystal is tuned during production process and tune values are stored in on board E2PROM.

### 3.2.2. Sleep clock

The sleep clock is delivered from a external 32 kHz oscillator. This clock as from external source is required for Bluetooth low power mode applications.

## 3.3. Start up and Reset

A low level at POWER\_DOWNn pin turns off internal 1V8 LDO, but 3V0 band gap reference remain on. A low level at RESETn pin turns off IC, this pin is also used for basic reset operation.

The both pins POWER\_DOWNn and RESETn have internal 10K Ohm pull-down resistors. It is distinguished between powering and reset.

### 3.3.1. Powering

While powering external voltages VCC\_VIO\_X1/2 VCC\_3V3 are turned on. For correct functionality the start-up timing below has to follow. An additional reset isn't necessary. The VCC\_VIO\_X1 and X2 can be turned on before VCC\_3V3 but latest concurrently with it. The time between rising of VCC\_VIO\_X1/2 and VCC\_3V3 isn't specified and can be unrestricted.

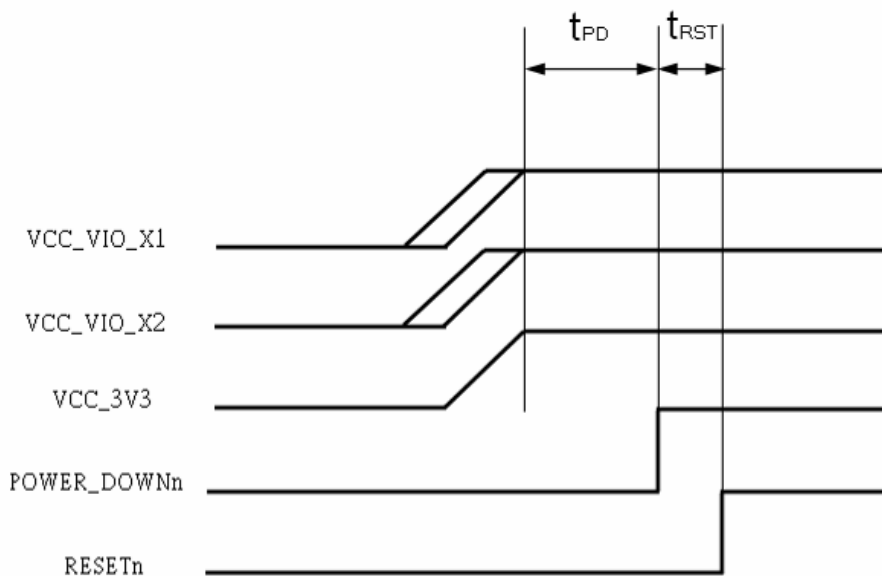

Start up timing				
	min	typ	max	unit
RESETn to VCC_3V3, $t_{PD}$	700	-	-	ms
RESETn to POWER_DOWNn, $t_{RST}$	5	-	-	ms

### 3.1 powering

#### 3.3.2. Reset

After powering the IC correctly, it can be anytime reset by pulling down of signal RESETn for at least 5 ms (Pic 3.1). The reset by POWER\_DOWNn-RESETn sequence is also possible. In this case the duration of POWER\_DOWNn should be at least 700 ms.

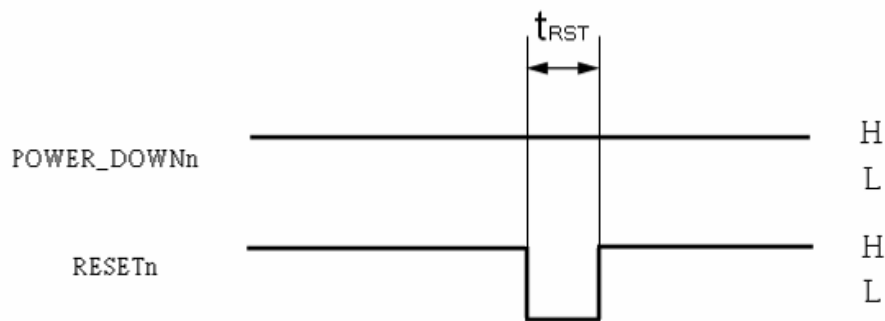

Start up timing				
	min	typ	max	unit
RESETn, $t_{RST}$	5	-	-	ms

### 3.2 Reset by RESETn

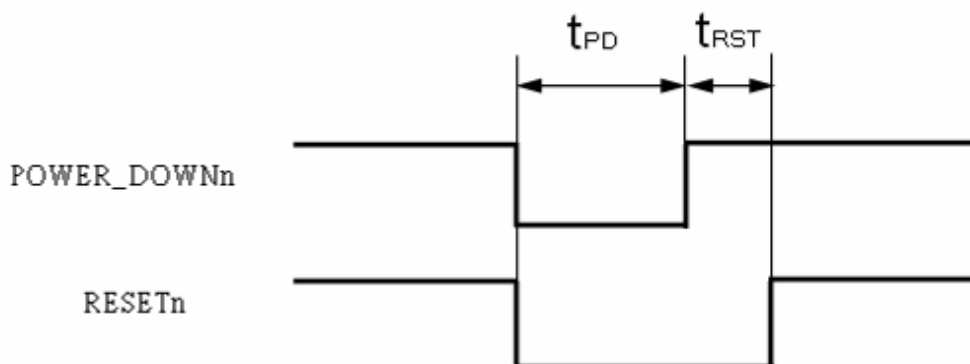

Start up timing				
	min	typ	max	unit
t <sub>PD</sub>	700	-	-	ms
t <sub>RST</sub>	5	-	-	ms

### 3.3 Reset by RESETn and POWER\_DOWNn

### 3.4. Antenna diagnose circuit

The picture below shows the principle of antenna diagnose circuit.

Requirement for functionality of circuit is that the external antenna has a internal DC path to ground with real impedance value of 51K Ohm.

This impedance builds with in module built-in resistor of 51K Ohm a voltage divider. By measuring and evaluation of voltage in divider midpoint it is possible to detected 3 states of antenna connection:

- open, measured voltage is equal supply voltage of antenna diagnose circuit
- antenna is connected correctly, measured voltage is equal the half of supply voltage antenna diagnose circuit
- Antenna is shorted to GND, measured voltage is equal 0V

Those three states are detected if supply voltage of antenna diagnose circuit (pins VCC\_BT\_ANT\_DIAG or VCC\_WLAN\_ANT\_DIAG) is equal reference voltage of ADC.

In case that supply voltage is lower than ADC reference voltage it is possible to detect one more state:

- Antenna has bypass to higher voltage source (for example to UBAT), the measured voltage is higher than supply voltage of antenna diagnose circuit.

On system side can be used a low pass filter for filtering. Good results can be achieved when C1=220nF and R1=51K Ohm, in this case the resistor R1 limits the current into ADC if antenna connector is shorted to battery voltage too.

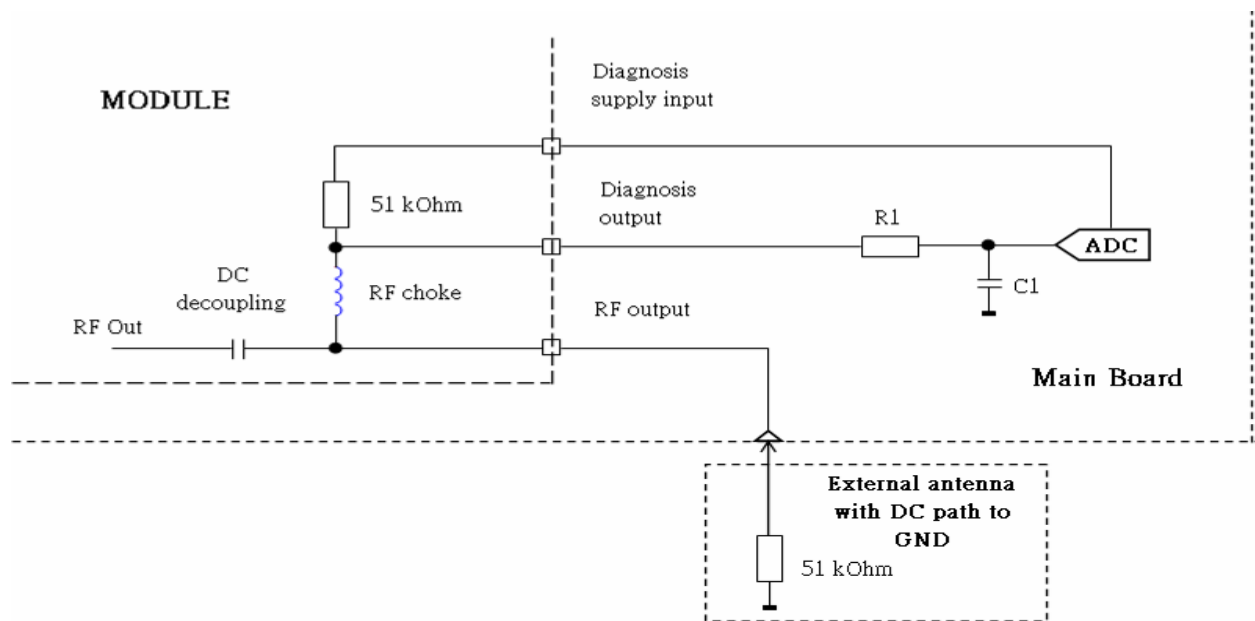

### 3.5. Power supply

#### 3.5.1. Main power

All for functionality necessary power supplies are generated by into module integrated 1.8 V LDO, 1V and 3.0 V band gap reference. The digital core supply of 1,2V is generated by in 88W8688 integrated LDO powering external voltages VCC\_VIO\_X1/2 VCC\_3V3 are turned on.

For correct functionality the start-up timing below has to follow. An additional reset isn't necessary. The VCC\_VIO\_X1 and X2 can be turned on before VCC\_3V3 but latest concurrently with it. The time between rising of VCC\_VIO\_X1/2 and VCC\_3V3 isn't specified and can be unrestricted.

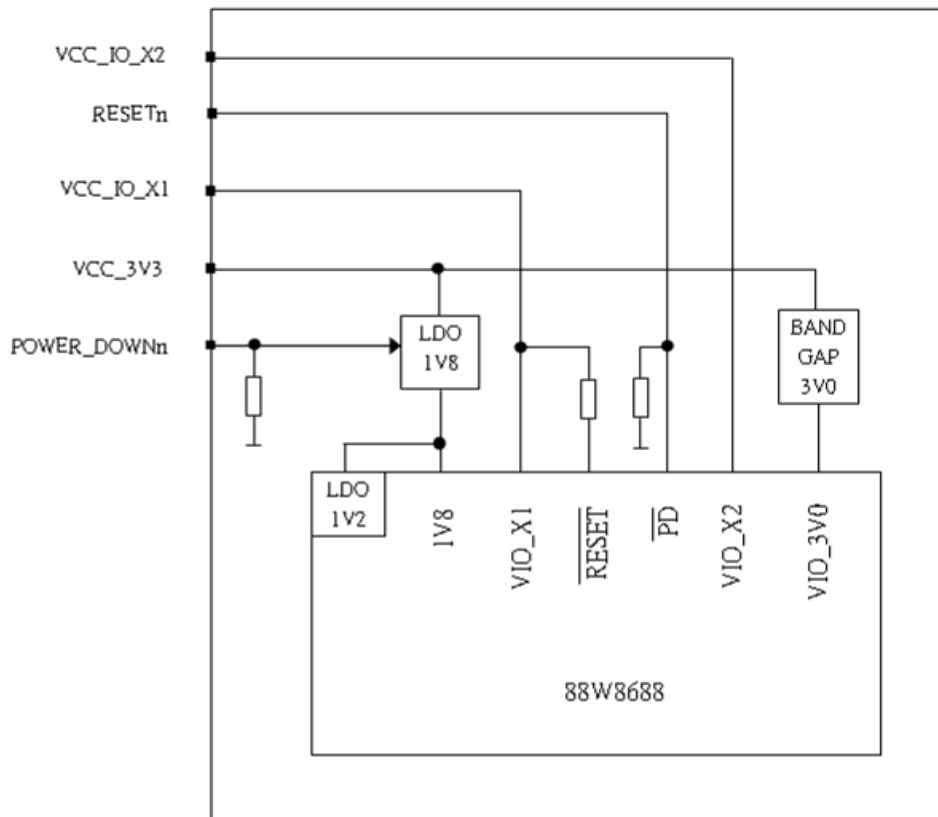

3.4 Power supply structure

### 3.5.2. Supply of I/O pins

The I/O pins are grouped in two supply domains: VCC\_VIO\_X1 and VCC\_VIO\_X2. Basically each domain can be powered either from 1,8V or 3,3V, but in circuits used E2PROM can't be powered by dual voltage. So supply of the VCC\_VIO\_X2 domain is specified by E2PROM chip. The supply for VCC\_VIO\_X2 can be chosen at ordering. The supply for VCC\_VIO\_X1 can be free chosen.

### 3.5.3. Power Down Mode

The module can be put into power down mode by signal POWER\_DOWNn (Pin 50, active level low).

Please note that 3V0 bang gap reference always remains on and consumes about 10 mA even if the IC and 1V8 LDO are powered down. From Power Down Mode the module can be wacked up by powering sequence (pic. 3.1).

## 4. Electrical specification

### 4.1. Absolute maximum ratings

Symbol	Parameter	Min.	Max.	Units
VIO_X1	Power supply voltage with respect to VSS	0	2.3	V
		0	4.2	V
VIO_X2	Power supply voltage with respect to VSS	0	2.3	V
		0	4.2	V
3V3	Power supply voltage with respect to VSS	0	3.45	V
T <sub>stg</sub>	Storage temperature	-40	+85	°C

### 4.2. Operating conditions

#### 4.2.1. Environmental conditions

Symbol	Parameter	Min.	Typ.	Max.	Units
T <sub>a</sub>	Ambient temperature range	-40		+85	°C

#### 4.2.2. Power supply

Symbol	Parameter	Min.	Typ.	Max.	Units
VIO_X1	Host Interface digital I/O power supply	16.2	1.8	1.98	V
		2.97	3.3	3.63	V
VIO_X2	Digital I/O power supply	16.2	1.8	1.98	V
		2.97	3.3	3.63	V
3V3		3.15	3.3	3.45	V
I_VIO_X1	Current Supply VIO_X1		tbd	205	mA
I_VIO_X2	Current Supply VIO_X2		tbd	125	mA
I_3V3	Current Supply 3V3	-	285	400	mA

### 4.2.3. Digital pins

Symbol	Parameter	VCC_VIO	Min.	Typ.	Max.	Units
POWER_ DOWNn	Power Down input, High	-	1.4	-	5.5	V
	Power Down input, Low	-	-0.3	-	0.5	V
Vin	Input high voltage	1.8	1.2	-	V18+0.3	V
		3.3	2.3	-	V33+0.3	V
Vin	Input low voltage	1.8	-0.3	-	0.6	V
		3.3	-0.3	-	1.1	V
Vout	Output high voltage	1.8	1.22	-	-	V
		3.3	2.57	-	-	V
Vout	Output low voltage	1.8	-	-	0.4	V
		3.3	-	-	0.4	V

### 4.2.4. External Sleep Clock Timing

Symbol	Parameter	Min.	Typ.	Max.	Units
CLK	Clock Frequency Range	32 or 32.768 - 50 ppm	32 or 32.768	32 or 32.768 + 50 ppm	kHZ
THIGH	Clock high time	40	--	--	ns
TLOW	Clock low time	40	--	--	ns
TRISE	Clock rise time	--	--	5	ns
TFALL	Clock fall time	--	--	5	ns

### 4.2.5. RF Performance

#### 4.2.5.1 BT Radio Characteristics

Parameter Items	Specifications
Transmit Power Level	<b>Class 1.5:</b> 7.8 ± 0.8 dBm (2441Mhz), 7.8 ± 1.5 dBm (2402~2480Mhz), <b>Class 2.0:</b> 2.5 ± 0.8 dBm (2441Mhz), 2.5 ± 1.5 dBm (2402~2480Mhz),
Receive Sensitivity	-80dBm (GFSK), -77dBm ( $\pi/4$ -DQPSK), -77dBm (8DPSK)
Operating Frequency	2402 MHz to 2480 MHz



Parameter Items	Specifications
Channel	79
Carrier Spacing	1 MHz separation
Duplexing	Time Division Duplex
Hopping Rate	1600 hops/per second
Symbol Rate	1 Mbps (GFSK) 2 Mbps ( $\pi/4$ -DQPSK) 3 Mbps (8DPSK)
Modulation	GFSK BT =0.5 $\pi/4$ -DQPSK 8DPSK

#### 4.2.5.2 WLAN Radio Characteristics

Parameter Items	Specifications
Frequency Band	2.4000~2.4835Ghz (2.4G ISM Band)
Selectable Sub Channel	13 Channels ( $F=2412+n*5\text{Mhz}, n=0\sim 12$ )
Modulation	OFDM, DSSS (Direct Sequence Spread Spectrum), DBPSK, DQPSK, CCK, 16QAM, 64QAM
Supported Rates	1, 2, 5.5, 11 Mbps (802.11b) 6, 9, 12, 18, 24, 36, 48, 54 Mbps (802.11g)
Maximum Receiver Level	-10dBm with PER < 8% (802.11b) -10dBm with PER < 10% (802.11g)
Output Power	15 dBm $\pm$ 1.5 dBm for 1, 2, 5.5, 11Mbps (802.11b) 15 dBm $\pm$ 1.5 dBm for 6, 9 and >12Mhz (802.11g)
Carrier Frequency Accuracy	+/- 25ppm (+/-2ppm in 25°C)
802.11b Mode EVM	1.0 Mbps (BPSK) : <35% 2.0 Mbps (BPSK) : <35% 5.5 Mbps (QPSK) : <35% 11.0 Mbps (QPSK) : <35%
802.11g Mode EVM	6.0 Mbps (BPSK) : <-5.0dB 9.0 Mbps (BPSK) : <-8.0dB 12.0 Mbps (QPSK) : <-10.0dB 18.0 Mbps (QPSK) : <-13.0dB 24.0 Mbps (16-QAM) : <-16.0dB 36.0 Mbps (16-QAM) : <-19.0dB 48.0 Mbps (64-QAM) : <-22.0dB 54.0 Mbps (64-QAM) : <-25.0dB
802.11b Mode Sensitivity	PER <8%, Rx Sensitivity @ 1.0 Mbps : -90dBm PER <8%, Rx Sensitivity @ 11.0 Mbps : -86dBm

Parameter Items	Specifications
802.11g Mode Sensitivity	PER <10%, Rx Sensitivity @ 6.0 Mbps: -88dBm PER <10%, Rx Sensitivity @ 54.0 Mbps: -72dBm

## 5. Mechanical specification

### 5.1. Package Type

54pin LGA, 1,6mm pitch

### 5.2. Package dimensions

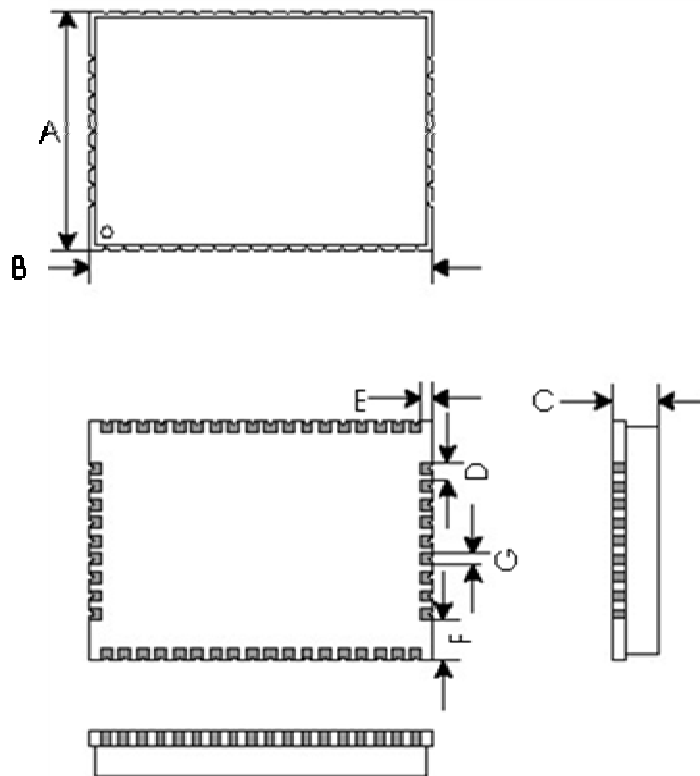

Figure 3 : Package dimensions

Parameter	Description	Min.	Typ.	Max.	Units
A	Height	0.15	21	0.15	mm
B	Width	0.15	30	0.3	mm
C	Thickness	0.2	4	0.15	mm
D	Pin to Pin Pitch	tbd	1.6	tbd	mm

E	Edge to Pin	tbd	0.9	tbd	mm
F	Edge to Pin	tbd	3.6	tbd	mm
G	Pin Width	tbd	1	tbd	mm
Weight				5	g

## 6. Labeling and ordering information

### 6.1. Product label

2 Product Labels of W50 have been placed on Shielding Frame and Shielding Case. For more information about the W50 Product Labels, please refer to the below 6.1.1 and 6.1.2.

#### 6.1.1. Shielding Frame Cover Label

The Label type of W50 Shielding Frame cover label is a 2D-Code Label with 9 \* 9 mm dimensions. The P/N has been defined as 4E.1HR02.001. The 2D-Code digits have been defined as below:

- 1st digit: Present the 2D-Code type.
- 2nd digits: Present the Main board type.
- 3rd~4th digits: Present the Model type.
- 5th~6th digits: Present the Date. Refer to the below figure for the Date code rules.

图1.0

"Year&Month" Code rule:

Month	1	2	3	4	5	6	7	8	9	10	11	12
1998; 2002; 2006; 2010	A	B	C	D	E	F	G	H	J	K	L	M
1999; 2003; 2007; 2011	N	P	Q	R	S	T	U	V	W	X	Y	Z
2000; 2004; 2008; 2012	A	B	C	D	E	F	G	H	J	K	L	M
2001; 2005; 2009; 2013	N	P	Q	R	S	T	U	V	W	X	Y	Z
2014; 2018; 2022; 2026	A	B	C	D	E	F	G	H	J	K	L	M
2015; 2019; 2023; 2027	N	P	Q	R	S	T	U	V	W	X	Y	Z
2016; 2020; 2024; 2028	A	B	C	D	E	F	G	H	J	K	L	M
2017; 2021; 2025; 2029	N	P	Q	R	S	T	U	V	W	X	Y	Z

2, 015

"Day" Code rule:

Day	1	2	3	4	5	6	7	8	9	10	
Code	1	2	3	4	5	6	7	8	9	A	
Day	11	12	13	14	15	16	17	18	19	20	
Code	B	C	D	E	F	G	H	I	K	L	
Day	21	22	23	24	25	26	27	28	29	30	31
Code	M	N	P	Q	R	S	T	U	V	W	X

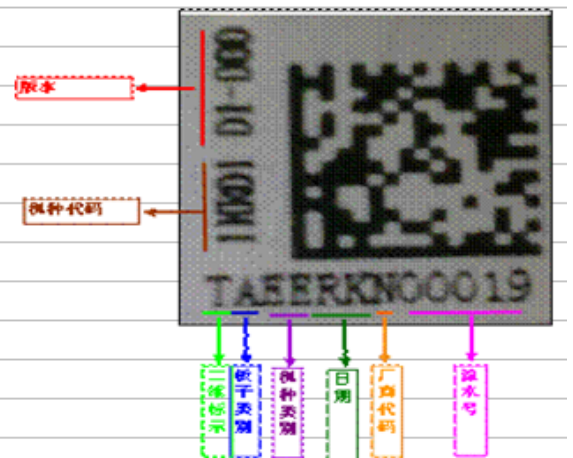

- 7th digit: Present the Factory code.
- 8th~12th digits: Present the serial number.

#### 6.1.2. Shielding Case Cover Label

The W50 Shielding Case cover label with 13 \* 13 mm dimensions, defined as 4E.1HR01.001, included below information:

- A. 2D-Barode: The digital definition refer to the below 2D Barcode Definition chart.

- B. P/N: Present the Harman PCBA Part Number.
- C. S/N: Present the Harman Serial Number.
- D. EC: Present the Engineering Changer Number.

2D Barcode Definition (1/3)						
	xxx	1xxxxxxx	xx	01	xxxxxxxx,	LICHRG#
Desc.	Qisda Supplier Code	Harman Serial No.	EC Level	Harman Module No.	Harman PCBA Part No.	Fixed Specified Key
Digits	3 digits	9 digits	2 digits	2 digits	8 digits+1	7 digits

2D Barcode Definition (2/3)						
YYYYMMDD,	KD_PC#	GW50,	KD_SN#	9J1HR01001	S0x,	MAC-ADR#
Supplier Production Date,	Fixed Specified Key	Qisda Internal Project No.	Fixed Specified Key	Qisda Internal Part No.	Qisda Internal Version No.	Fixed Specified Key
8 digits+1	6 digits	4 digits+1	6 digits	10 digits	3 digits+1	8 digits

2D Barcode Definition (3/3)		
xxxxxxxxxxxx,	BLUE-TOOTH#	xxxxxxxxxxxx,
WiFi MAC,	Fixed Specified Key	BT MAC,
12 digits+1	11 digits	12 digits+1

## 6.2. Ordering information

Ordering No.	Product
CWM-01-3V3	Bluetooth/WLAN Module 3,3V supply

## 7. Product handling

### 7.1. Packaging

Below Table 1 displays the W50 Packaging list, including Humidity Protec-

tion Materials, Packing Materials, Labels, and Taps. For more information about the illustration of W50 packaging materials, please refer to the Figure 1 and Figure 2.

Table 1 W50 Packaging table

Type	Item	Spec.	Qisda P/N	Packaging Figure No.
1. Humidity Protection Materials	Aluminum Bag	L460 * W410 * T0.15 mm ALUMINUM BAG GW50	4G.1HR01.00 1	8
	Humidity Indicator	CARD HUMIDITY INDICATOR GP	4J.G3501.002	9
	DESICCANT BAG	DESICCANT BAG 68*89	3H.09005.001	12
2. Packing Materials	Taping Reel	PLATE TAPING REEL 13IN. GW50	4B.1HR02.001	4
	Pizza Box	L356 * W344 * T61 mm	4D.1HR01.001	10
	Carton	L355 * W340 * T386 mm (Pizza Box * 5)	4D.1HR02.001	1
3. Labels	OOB Label	100*50mm	4E.1HR03.001	2
	Carton Label	50*15mm (Print on Carton )	X	3
	Caution label	LABEL ATTENTION 56M31 55 mm * 55 mm	4E.G3503.001	11
4. Taps	Cover Tap	COVER TAPE GW50	4B.1HR01.001	5
	Carrier Tap	CARRIER TAPE GW50	4B.1HR03.001	6

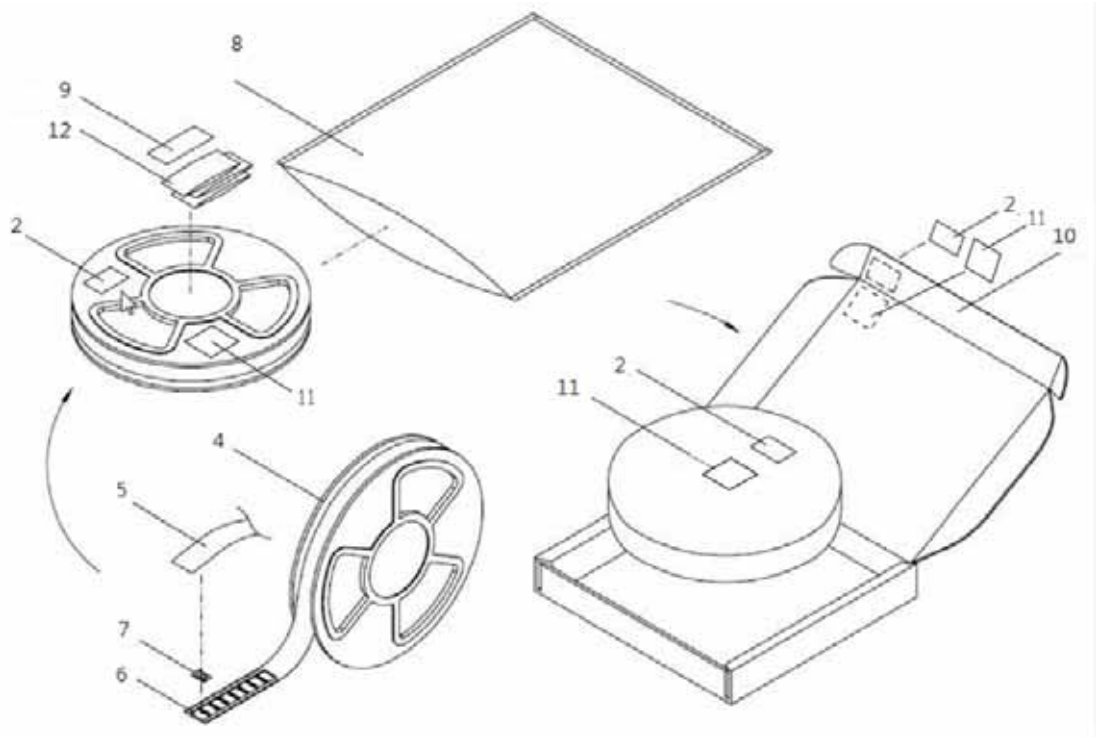

Figure 1 W50 Packaging 1/2

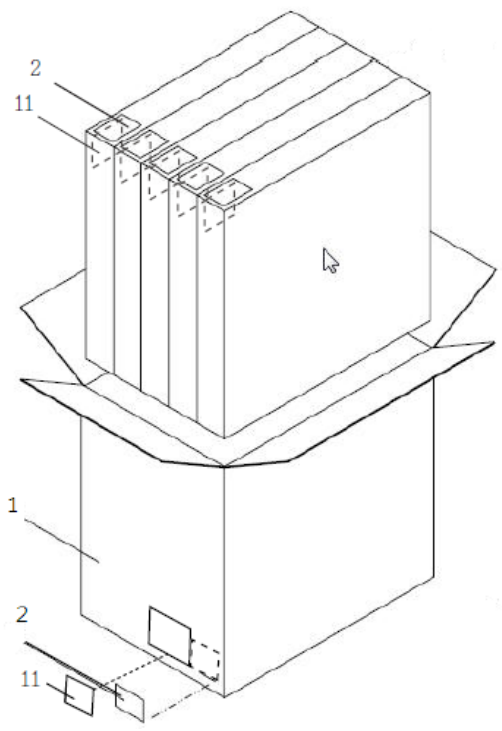
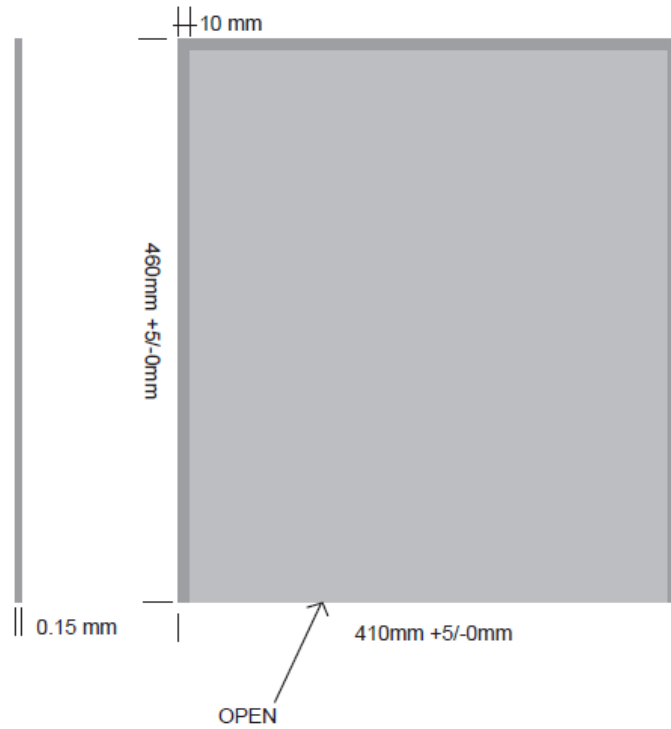

Figure 2 W50 Packaging 2/2

## 7.2. Packing Materials

### 7.2.1. Humidity Protection Materials

**7.2.1.1. Aluminum Bag:** The L460\*W410\*T0.15 mm dimensions Aluminum bag is prepared for the W50 module vacuum packing on the Humidity protection purpose. The P/N has been defined as 4G.1HR01.001. Please see the below illustration and picture for the W50 Aluminum bag:





**7.2.1.2. Humidity Indicator:** The L102\*W38 mm dimensions Humidity Indicator is prepared for including in the W50 Aluminum Bag on the Humidity Inspection purpose. The P/N has been defined as 4J.G3501.002. Please see the below illustration and picture for the W50 Humidity Indicator:

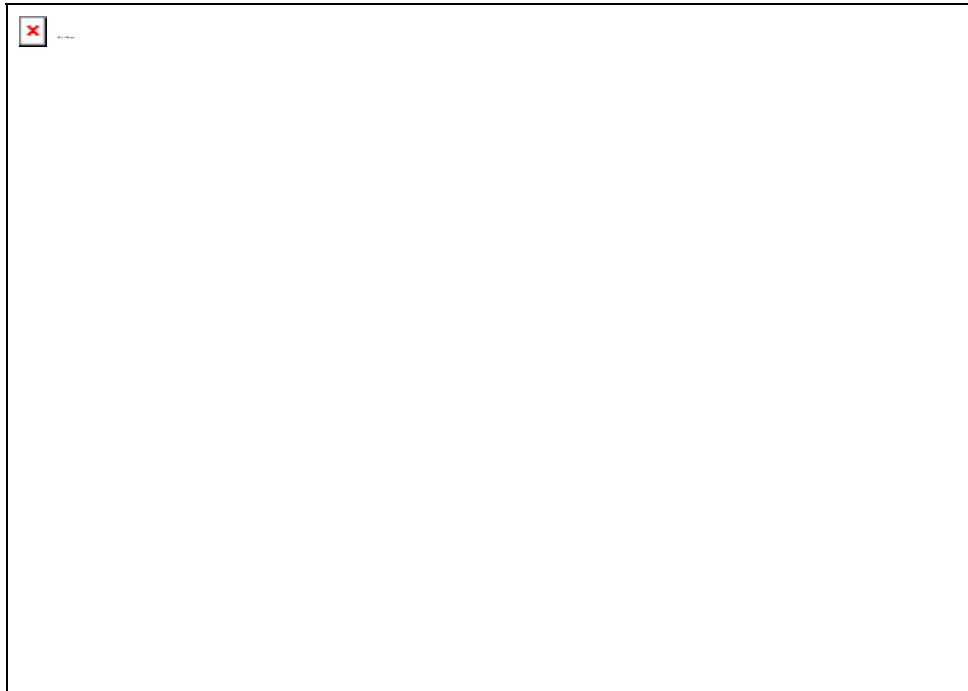

**7.2.1.3. Desiccant:** The L89\*W68 mm dimensions and Mineral Bentonite inside Desiccant is prepared for the W50 module packaging on the Humidity prevention purpose. The P/N has been defined as 3H.09005.001. Please see the below illustration and picture for the W50 Desiccant:

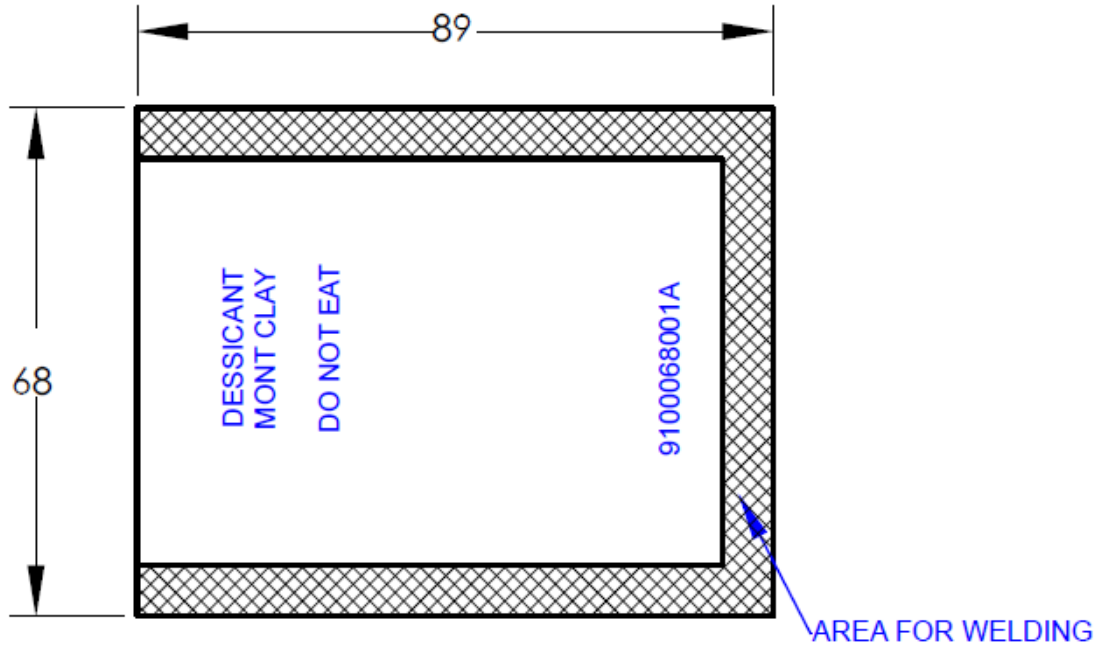

**7.2.2. Packing Materials**

**7.2.2.1. Reel:** The 13" dimension and PS Black Reel is prepared for the W50 module packaging, met to ESD standard Ohm:  $10^7\Omega \sim 10^{11}\Omega$  and EIA-471-D. The P/N has been defined as 4B.1HR02.002. Please see the below illustrations and pictures for the W50 Reel:

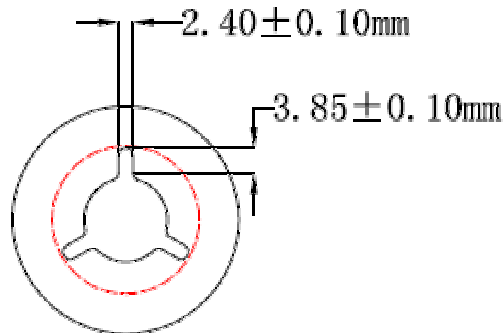
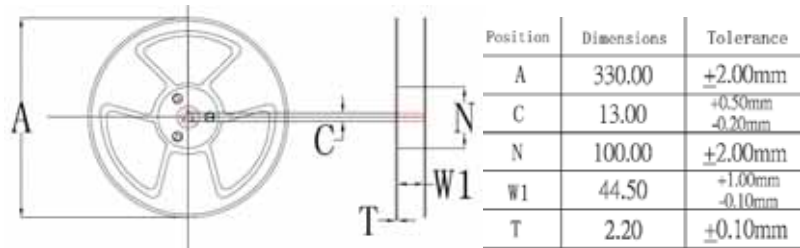

**7.2.2.2. Pizza Box:** The L356\*W344\*T61mm dimensions and B Flute Pizza Box is prepared for the W50 Reel(with Aluminum Bag) inside. The P/N has



7.2.2.3. **Carton:** The L355\*W340\*T384mm dimensions and AB/F Carton is prepared for the 5 Pizza Boxes inside. The P/N has been defined as 4D.1HR02.001. Please see the below illustration and picture for the W50 Carton:

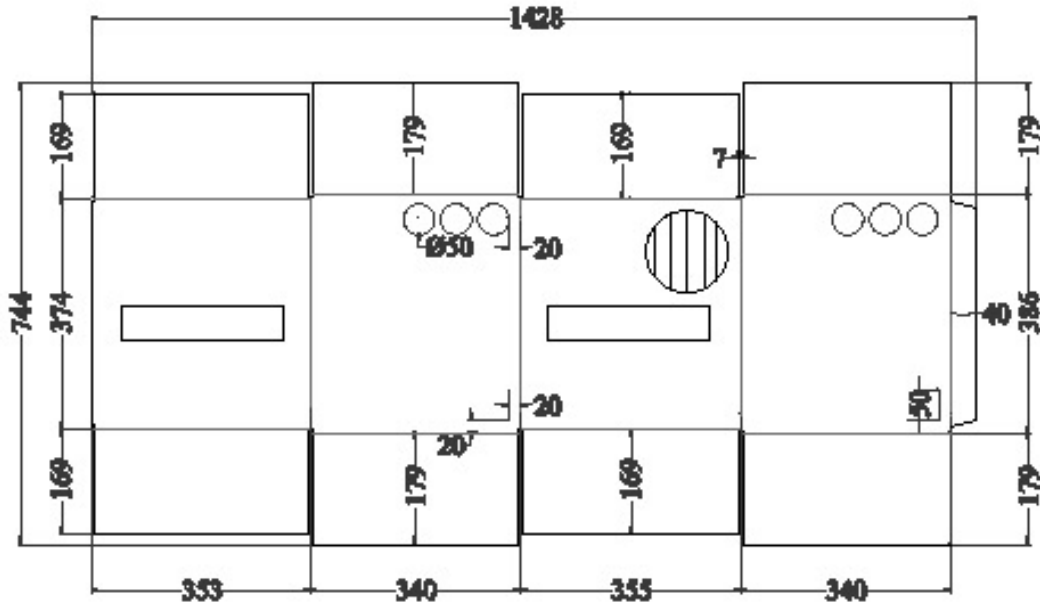

7.2.3. Labels

7.2.3.1. OOB Label: 4 OOB Labels on Reel, Aluminum Bag, Pizza Box and Car-

ton are placed for the W50. For more information about the W50 OOB Labels, please refer to the below description.

The W50 OOB Label on Reel with 100 \* 50 mm dimensions defined as 4E.1HR01.001. Please see the below picture illustration and detail information.



Item	Content	Remark
Reel ID	R+Year+Month+SN	SN is from 0001~9999 Ex. R2011040001
PIO No	Defined by Harman, will be changed for each shipment	
Lot No	L+Year+month+SN	(a) 5 Pizza boxes are in 1 Lot. (b) SN is from 0001~9999 Ex. L2011040001
Model No	GW50	Qisda Model No.
Harman Part No	Defined by Harman, will be changed for each shipment	C1b sample:2318091 C3/D1 sample:2321122 D2 sample : 2357720
Part No.	9J.1HR01.001	Qisda Part No.

Item	Content	Remark
General Desc.	MOD-SM Qisda BT/WLANCWM-01.C1A	Add sample build status, Ex.C1a.EVT3-2/C1b.EVT3-3/C3.EVT3-4
Q'ty	400	400 pcs for each Reel
EC	Started at 03 and be updated by every pilot run	<b>EVT 3-2(C1a):</b> EC05/ 3-3 (C1b): EC06/ 3-4(C3): EC07 <b>DVT (D1a/b):</b> EC08/ (D2): EC09
FCC ID	VRSGW50	

The **W50 OOB Label on Aluminum Bag** with 100 \* 50 mm dimensions defined as 4E.1HR01.001. Please see the below picture illustration and detail information.



Item	Content	Remark
Bag ID	A+Year+Month+SN	SN is from 0001~9999 Ex. A2011040001
PIO No	Defined by Harman, will be changed for each shipment	

Item	Content	Remark
Lot No	L+Year+month+SN	(a) 5 Pizza boxes are in 1 Lot. (b) SN is from 0001~9999 Ex. L2011040001
Model No	GW50	Qisda Model No.
Harman Part No	Defined by Harman, will be changed for each shipment	C1b sample:2318091 C3/D1 sample:2321122 D2 sample :2357720
Part No.	9J.1HR01.001	Qisda Part No.
General Desc.	MOD-SM Qisda BT/WLANCWM-01.C1A	Add sample build status, Ex.C1a.EVT3-2/C1b.EVT3-3/C3.EVT3-4
Q'ty	400	400 pcs for each Aluminum Bag
EC	Started at 03 and be updated by every pilot run	<b>EVT</b> 3-2(C1a): EC05/ 3-3 (C1b): EC06/ 3-4(C3): EC07 <b>DVT</b> (D1a/b): EC08/ (D2): EC09
FCC ID	VRSGW50	

The **W50 OOB Label on Pizza Box** with 100 \* 50 mm dimensions defined as 4E.1HR01.001. Please see the below picture illustration and detail information.



Box ID: B2011110003  
  
P/O No: 45004234962  
  
LOT No: L2011110001  
  
Model No: GW50  
Harman Part No: 02321122  
  
Part No: 9J.1HR01.001  
  
General Desc: MOD-SM Qisda BT/WLAN CWM-01,C3 EC:08  
Q'ty: 400  
  
QC Inspected OK  
FCCID VRSGW50



Item	Content	Remark
Box ID	B+Year+Month+SN	SN is from 0001~9999 Ex. B2011040001
PIO No	Defined by Harman, will be changed for each shipment	
Lot No	L+Year+month+SN	(a) 5 Pizza boxes are in 1 Lot. (b) SN is from 0001~9999 Ex. L2011040001
Model No	GW50	Qisda Model No.
Harman Part No	Defined by Harman, will be changed for each shipment	C1b sample:2318091 C3/D1 sample:2321122 D2 sample : 2357720
Part No.	9J.1HR01.001	Qisda Part No.
General Desc.	MOD-SM Qisda BT/WLANCWM-01.C1A	Add sample build status, Ex.C1a.EVT3-2/C1b.EVT3-3/C3.EVT3-4
Q'ty	400	400 pcs for each Pizza Box
EC	Started at 03 and be updated by every pilot run	EVT 3-2(C1a): EC05/ 3-3 (C1b): EC06/ 3-4(C3): EC07

Item	Content	Remark
		DVT (D1a/b): EC08/ (D2): EC09
FCC ID	VRSGW50	

The **W50 OOB Label on Carton** with 100 \* 50 mm dimensions defined as 4E.1HR01.001. Please see the below picture illustration and detail information.



Item	Content	Remark
Carton ID	C+Year+Month+SN	SN is from 0001~9999 Ex. C2011040001
PIO No	Defined by Harman, will be changed for each shipment	
Lot No	L+Year+month+SN	(a) 5 Pizza boxes are in 1 Lot. (b) SN is from 0001~9999
Model No	GW50	Qisda Model Number
Harman Part No	Defined by Harman, will be changed for each shipment	(a) EVT3-3(C1b sample): 02318091 (b) EVT3-4(C3 /D1 sample): 02321122

Item	Content	Remark
	ment	(c ) D2 sample : 02357720
Part No.	9J.1HR01.001	Qisda Part Number
General Desc.	MOD-SM Qisda BT/WLAN CWM-01.CXX	Add sample build status as "XX" Ex.C1A=EVT3-2/C1B=EVT3-3/ C3=EVT3-4
Q'ty	Depend on shipment Q'ty	400 pcs for 1 Reel, Max Q'ty is 2000 pcs for each Carton
EC	Start from 03 and be updated by every pilot run	EVT 3-2(C1a): EC05/ 3-3 (C1b): EC06/ 3-4(C3): EC07 DVT (D1a/b): EC08/ (D2): EC09
FCC ID	VRSGW50	

**7.2.3.2. Carton Label:** The L50\*W15 mm dimensions' Carton Label, printed on Carton, is prepared for the W50 moving caution language. Please see the below picture on the W50 Carton:



**7.2.3.3. Caution Label:** The L55\*W55 mm dimensions' Caution Label is pre-

pared for the ESD Indicator purpose. The P/N has been defined as 4E.G3503.00. Please see the below illustration and picture for the W50 Caution Label:



**7.2.4. Tapes:** The 400 pcs W50 of per Reel with PS Black Cover and Carrier Tapes are prepared for the W50 Module packaging, met to ESD standard Ohm:  $10^4\Omega \sim 10^6\Omega$  and EIA-481-D. The P/N has been defined as Cover Tap-4B.1HR01.001 and Carrier Tap-4B.1HR03.001. Please see the below illustration and pictures for the W50 Carrier and Cover Tapes:

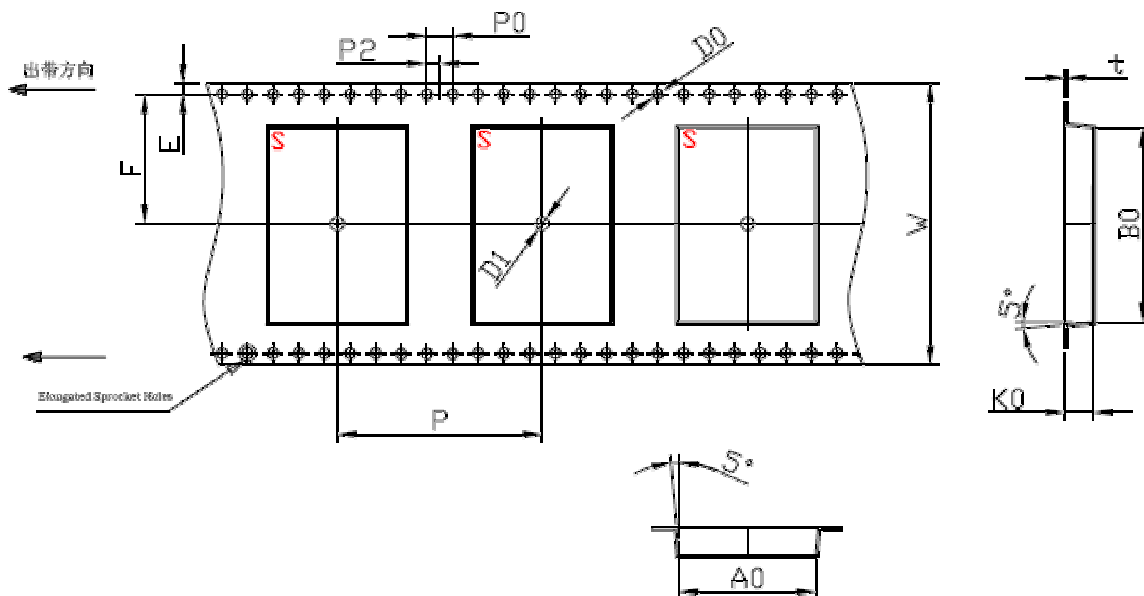



### 7.3. Shipment, storage and handling

The W50 Shipment, Storage and Handling are based and acting on per Carton with 5 Pizza Box packages and 2,000 pcs W50 inside.

## 8. Certifications

### 8.1. FCC Regulations:

This device complies with part 15 of the FCC Rules. Operation is subject to the following two conditions: (1) This device may not cause harmful interference, and (2) this device must accept any interference received, including interference that may cause undesired operation.

This device has been tested and found to comply with the limits for a Class B digital device, pursuant to Part 15 of the FCC Rules. These limits are designed to provide reasonable protection against harmful interference in a residential installation. This equipment generates, uses and can radiated radio frequency energy and, if not installed and used in accordance with the instructions, may cause harmful interference to radio communications. However, there is no guarantee that interference will not occur in a particular installation. If this equipment does cause harmful interference to radio or television reception, which can be determined by turning the equipment off and on, the user is encouraged to try to correct the interference by one or more of the following measures:

- Reorient or relocate the receiving antenna.
- Increase the separation between the equipment and receiver.
- Connect the equipment into an outlet on a circuit different from that to which the receiver is connected.
- Consult the dealer or an experienced radio/TV technician for help.

Changes or modifications not expressly approved by the party responsible for compliance could void the user's authority to operate the equipment.

### **RF Exposure Information**

This Modular Approval is limited to OEM installation for mobile and fixed applications only. The antenna installation and operating configurations of this transmitter, including any applicable source-based time-averaging duty factor, antenna gain and cable loss must satisfy MPE categorical Exclusion Requirements of §2.1091.

The antenna(s) used for this transmitter must be installed to provide a separation distance of at least 20 cm from all persons, must not be collocated or operating in conjunction with any other antenna or transmitter, except in accordance with FCC multi-transmitter product procedures.

The end user has no manual instructions to remove or install the device and a separate approval is required for all other operating configurations, including portable configurations with respect to 2.1093 and different antenna configurations.

Maximum antenna gain allowed for use with this device is 2 dBi.

When the module is installed in the host device, the FCC ID label must be visible through a window on the final device or it must be visible when an access panel, door or cover is easily re-moved. If not, a second label must be placed on the outside of the final device that contains the following text: "Contains FCC ID: VRSGW50".

## **9. Contact**

Qisda Corporation  
18 Jihu Road, Neihu,  
Taipei 114, Taiwan  
Tel: +886 2 2799-8800  
Fax: +886 2 2799-9688  
Website: Qisda.com