

Dell™ Streak
User's Manual



Notes, Cautions, and Warnings



NOTE: A NOTE indicates important information that helps you make better use of your device.



CAUTION: A CAUTION indicates potential damage to hardware or loss of data if instructions are not followed.



WARNING: A WARNING indicates a potential for property damage, personal injury, or death.

Information in this document is subject to change without notice.

© 2010 Dell Inc. All rights reserved.

Reproduction of these materials in any manner whatsoever without the written permission of Dell Inc. is strictly forbidden.

Trademarks used in this text: *Dell* and the *DELL* logo are trademarks of Dell Inc.

Adobe Acrobat is a trademark of Adobe Systems Incorporated which may be registered in certain jurisdictions; Microsoft, Windows, Microsoft Office Word, Microsoft Office Excel, and Microsoft Office PowerPoint, are either trademarks or registered trademarks of Microsoft Corporation in the United States and/or other countries.

Other trademarks and trade names may be used in this document to refer to either the entities claiming the marks and names or their products. Dell Inc. disclaims any proprietary interest in trademarks and trade names other than its own.

March 2010

Federal Communications Commission (FCC) Statement

This device complies with Part 15 of the FCC Rules. Operation is subject to the following two conditions:

- 1) this device may not cause harmful interference and
- 2) this device must accept any interference received, including interference that may cause undesired operation of the device.

FCC RF Radiation Exposure Statement:

For body worn operation, this phone has been tested and meets FCC RF exposure guidelines when used with an accessory that contains no metal and that positions the handset a minimum of 1.5 cm from the body. Use of other accessories may not ensure compliance with FCC RF exposure guidelines.

Contents

1	Package Contents	7
2	Dell™ Streak Features.	8
3	Setting Up Your Dell™ Streak	11
	Getting Your Device Ready for Use	11
	Turning On Your Device	14
	Turning Off Your Device	14
	Turning Off the Screen.	14
4	Understanding Your Dell™ Streak.	15
	Touch Screen	15
	Screen Orientation.	18
	Applications, Widgets, and Shortcuts.	18
	Home Screen.	19
	Status Bar	25
	Navigating the Applications.	28
5	Using Your Dell™ Streak	30

	Calling	30
	Text Messages	36
	Pop-Up Menu	42
	On-Screen Keyboard	42
	Widgets	46
	Managing Contacts	48
	Managing Your Device Settings	51
6	Web	53
	Connecting to the Web	53
	Browsing the Web	57
	E-mail	62
	Web Applications	64
7	Customizing Your Dell™ Streak	88
	To change display settings	88
	To change sound and ringtone settings	89
	To manually set the date, time and time zone	90
	To choose a language	92
8	Protecting Your Dell™ Streak	93
	Protect Your Device Data With a Screen Unlock Pattern	93

	Protect Your SIM Card With the SIM Lock Password	95
9	Applications	97
	Camera	97
	MicroSD	102
	Bluetooth®	104
	Photos & Videos	106
	Music.	108
	Calendar	111
	Alarm Clock	112
	Calculator	114
	Recorder	114
	Voice Control.	115
	Outlook Tasks	116
	SIM Manager	117
	Outlook Notes	118
	Quickoffice.	118
10	Synchronizing Your Dell™ Streak and Computer Using Dell PC Suite	120
	Connect to a Computer and Install Dell PC Suite	120
	Using Dell PC Suite	121

11	Playing Videos on HDMI Devices	123
12	Troubleshooting	124

Package Contents

Check the contents of your package to verify that you have the following:

U.S.A

Streak device

Battery

Quick Start Guide

Safety, Environmental, and Regulatory Information

Warranty Service Information

USB cable

Charger

US plug

Pouch

Headset

EMEA

Streak device

Battery

Quick Start Guide

Safety, Environmental, and Regulatory Information

Warranty Service Information

USB cable

Charger

UK plug





EURO plug



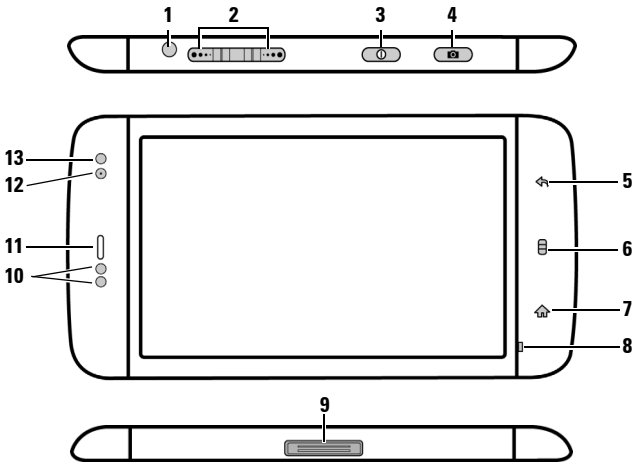

Pouch

Headset

Dell™ Streak Features



Buttons/Connectors/Parts	Functionality
1 Headphone connector	Connects to headphones.
2 Volume up/down button Landscape mode: Volume up button  / Volume down button  Portrait mode:  Volume up button  Volume down button	<ul style="list-style-type: none"> While playing media such as music tracks or video clips: <ul style="list-style-type: none"> Press to increase or decrease the media volume by one level. Press and hold to continuously increase or decrease the media volume. Press either button to mute the ringer while receiving a call. In all other situations: <ul style="list-style-type: none"> Press to increase or decrease the ringer volume by one level. Press and hold to continuously increase or decrease the ringer volume.

Buttons/Connectors/Parts	Functionality
3 Power and Sleep/Wake button 	<ul style="list-style-type: none"> • If the device is off, press and hold to power on the device. • If the device is on, but the screen is off, press to turn on the screen. • If both the device and the screen are on, <ul style="list-style-type: none"> – Press to turn the screen off. – Press and hold to select one of these options: <ul style="list-style-type: none"> Silent mode: The device does not vibrate and disables all sounds except for alarms. Airplane Mode: Select to disable all wireless connections. Power off: Turn off the device.
4 Camera button 	<ul style="list-style-type: none"> • If the camera is not active, press and hold to start the camera. • If the camera is active, press to capture a photo or record a video. • When recording a video, press to stop.
5 Back button 	Touch to return to the previous screen, close a dialog box, menu, or pop-up message, and to dismiss the keyboard.
6 Menu button 	<ul style="list-style-type: none"> • Touch to open or close the pop-up menu displaying available options for the current application or actions that you can perform on the current screen. • Touch and hold to bring up the on-screen keyboard for text input.
7 Home button 	<ul style="list-style-type: none"> • Touch to return to the Home screen. • Touch and hold: <ul style="list-style-type: none"> – For quick access to the recently accessed applications. – Add or delete additional Home screens.

Buttons/Connectors/Parts	Functionality
8 Microphone	Use for voice calls
9 30-pin connector	<ul style="list-style-type: none"> • Connects to a USB cable to transfer files to a computer. • Connects to a charger to charge the device. • Connects to the Home Dock for audio and video output.
10 Proximity sensors	Turn off the screen as you bring the device close to your face to make or receive a call, in order to prevent unintentional touches.
11 Earpiece	Use to listen to phone conversations.
12 Front-facing camera lens	Use for taking a front view picture, e.g. self-portrait.
13 Ambient light sensor	Controls the screen brightness according to the surrounding lighting conditions.

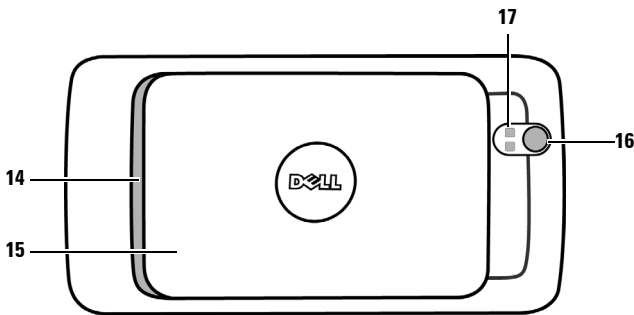

Parts/controls	Functionality
14 Speaker	Audio output for video and music playback.
15 Back cover	Secures the battery in place.
16 Camera lens	Captures pictures and videos.
17 Camera flash	For using flash to take pictures.

Setting Up Your Dell™ Streak

Getting Your Device Ready for Use

1 Remove the back cover

- a Slide the back cover downwards in the direction towards the end of the device.
- b Lift the back cover off the device.

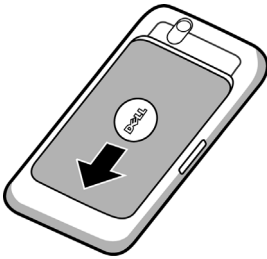



 **NOTE:** The device will shut down automatically if you remove the back cover while the device is on.

 **NOTE:** You cannot turn on the device if the back cover is removed.

2 Insert the SIM card

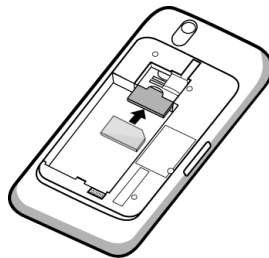
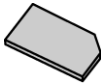
Insert the SIM card in the illustrated direction under the metal plate that covers the SIM card holder.



 **NOTE:** If you have trouble inserting the card, ensure that you have aligned the angled corner on the card with the corner of the card holder.

3 Insert the battery

Align the metal contacts on the battery with the contacts on the battery holder and insert the battery.

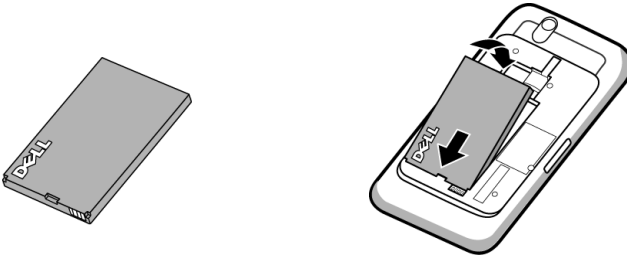

4 Install the microSD card

a Hold the microSD card with the metal contacts facing down.

b Slide the microSD card into the microSD card holder.

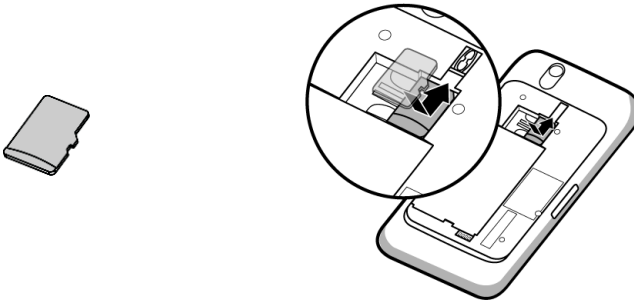

5 Close the back cover

- a Push the end of the back cover against the groove near the bottom of the device.
- b Place the cover onto the back of the device, and then push the cover towards the top of the device to secure the cover in place.



6 Charge the device

 **NOTE:** Charge the battery in an environmental temperature between 0°C and 45°C.

The battery is not fully charged when first unpacked.

- a Plug the supplied USB cable's 30-pin connector into the 30-pin connector on the device.
- b Plug the cable's USB connector into the supplied USB wall charger adaptor.
- c Plug the USB wall charger adaptor into a power outlet and charge the device till the battery is fully charged.

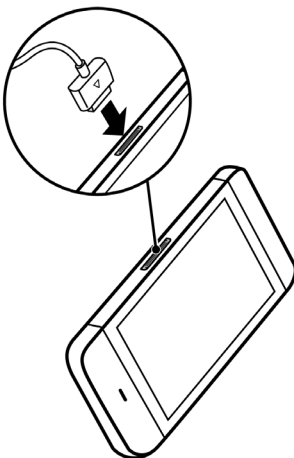



NOTE: The device is fully charged within four hours from a power outlet.

NOTE: To charge your device using a computer, connect the supplied USB cable's 30-pin connector to the device, and the cable's USB connector to a USB port on the computer.

Turning On Your Device

 **NOTE:** Use this device in an environmental temperature between -10°C and 55°C.



- 1 Press and hold the Power button  in order to turn on your device. The operating system starts up.
- 2 Touch the Menu button  to unlock the screen if it is automatically locked.
- 3 If your SIM card is locked by a Personal Identification Number (PIN), type the PIN by touching the corresponding number keys using the on-screen keypad. Touch the **OK** button to confirm your input.
- 4 The device is ready for use when the home screen is displayed.

Turning Off Your Device

- 1 Press and hold the Power button .
- 2 Touch the Power off option on the screen.

Turning Off the Screen

If both the device and the screen are on, press the Power button  to turn off the screen.

 **NOTE:** If the device is on, but the screen is off, press the Power button  to turn on the screen.

Understanding Your Dell™ Streak



NOTE: To view the on-screen tutorial for basic controls of your device, on the Home screen touch , and follow the instructions on the screen to proceed.

Touch Screen

Your device has a multi-touch sensitive screen. You can touch the surface of the screen to operate the device.

Finger Gestures

Allows you to:

Touch

Tap gently on the screen with your fingertip.

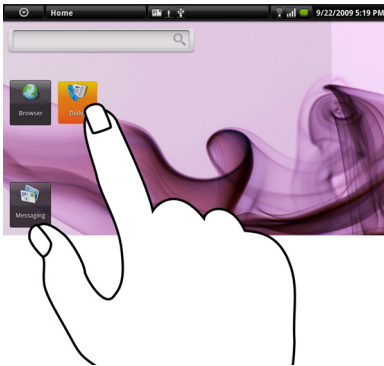

- Select the items on the screen including options, entries, images, and icons.
- Start applications.
- Press the buttons on the screen.
- Input text using the on-screen keyboard or numeric keypad.



Finger Gestures

Allows you to:

Touch and hold

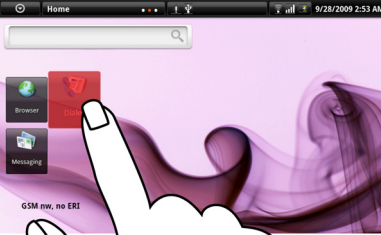
Touch and hold your finger on the screen.



- Move an item on the Home Screen.
- Add Home screens. Touch and hold the Home button  to add a Home screen.
- Open or close the on-screen keyboard. Touch and hold the Menu button  to open or close the on-screen keyboard.

Drag

- 1 Touch and hold your finger on an item on the screen.
- 2 Keeping your finger in contact with the screen, move your fingertip to the desired location.
- 3 Take your finger off the screen to drop the item in the desired location.

Move items such as images and icons on the screen.

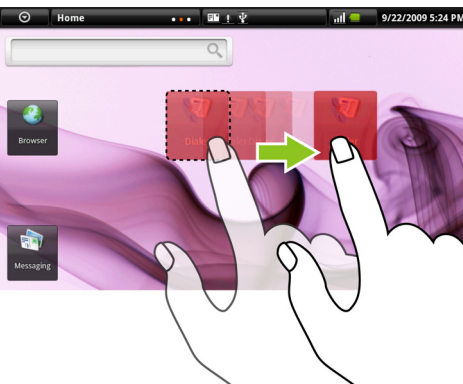

Finger Gestures

Allows you to:

Flick or swipe

Move your finger in a vertical or horizontal direction on the screen.

Scroll through Home screens, web pages, lists, entries, photo thumbnails, contacts, and so on.

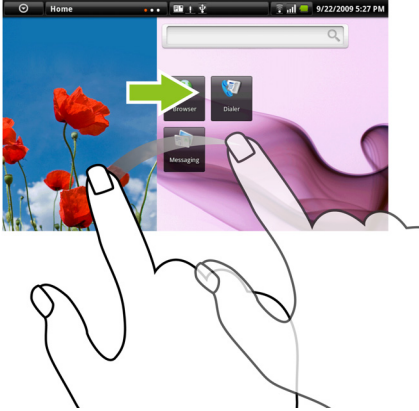

Zoom-out

Move two fingers close together on the screen.

Reduce the view of an image or web page (zoom out).

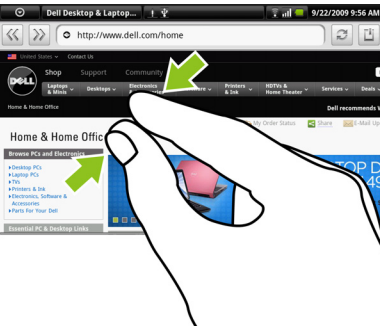

Finger Gestures

Allows you to:

Zoom-in

Move two fingers apart on the screen.

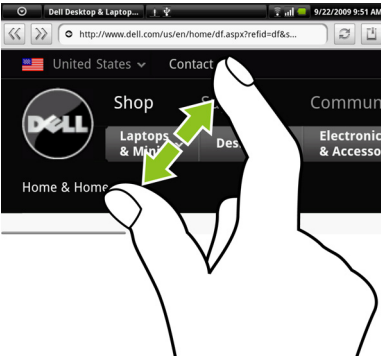

Enlarge the view of an image or web page (zoom in).



Screen Orientation

For optimal viewing experience, the screen orientation changes automatically to portrait or landscape depending on how you hold the device.

 **NOTE:** The Home screen is always displayed in landscape and does not automatically orient to portrait. Applications downloaded from Android Market may not support automatic screen orientation to portrait or landscape.

 **NOTE:** To modify the default behavior, open the orientation settings by touching the Home button  → Menu button  → **Settings** → **Sound & display** → **Orientation**.

Applications, Widgets, and Shortcuts



Application - Software which allows you to perform a specific task. Your device is preloaded with a variety of applications, and additional ones can be downloaded from the Android Market.

Widget - A small application which resides on the Home screen and provides quick and easy access to information. For example, the Facebook widget allows you read posts on your wall and update your status.

Shortcut - A link that you can put on your Home Screen in order to provide quicker access to an application or a folder containing contacts or bookmarks.



Home Screen

The Home screen displays widgets, folders, and shortcuts that provides easy access to your favorite or frequently-used applications. You can also display your favorite pictures as your Home screen wallpapers.

 **NOTE:** Touch the Home screen button  to return to the current home screen.

Multiple Home Screens



Your device supports additional Home screens to give you more space to display widgets, shortcuts or folders.

 **NOTE:** The dots  in the Home status area of the status bar indicate the total number of the Home screens. The colored dot indicates which Home screen is being viewed.

To navigate across the Home screens



Flick the Home screens horizontally until the desired one is displayed.

To add a Home screen

- 1 Touch  in the Home status area or touch and hold the Home button  to view the thumbnail of the available Home screens.
- 2 Touch the + icon to add a selected Home screen.

 **NOTE:** Your device supports a maximum of six Home screens.



To delete a Home screen

- 1 Touch  in the Home status area or touch and hold the Home button  to view the thumbnail of the available Home screens.
- 2 Touch the icon  on the top right corner of the Home screen that you desire to delete. The **Delete Room** message box appears.
- 3 Touch the **Yes** button to confirm deletion.

 **NOTE:** You cannot delete your last remaining Home screen.



Customizing Your Home Screen

To add an item to a Home screen



- 1 Touch the Home button .
- 2 To access the **Add to Home** screen menu, either:
 - Touch and hold an empty area on the home screen. The **Add to Home screen** menu appears.
 - Touch the Menu button  and then touch the **Add** option. The **Add to Home screen** menu appears.
- 3 Touch the item you want to add on the Home screen:

Items	Steps
<p>Shortcuts</p> <p>Add shortcuts for items that you wish to access directly from the Home screen.</p>	<ul style="list-style-type: none"> • Applications: <ol style="list-style-type: none"> 1 Scroll through the application menu to locate the desired application. 2 Touch the desired application to create the shortcut on the current Home screen. • Bookmark: <ol style="list-style-type: none"> 1 Flick through the Bookmarks list to locate the desired bookmark. 2 Touch the desired bookmark to create the shortcut on the current Home screen. • Contacts: <ol style="list-style-type: none"> 1 Flick through the Contacts entries to locate the desired contact. 2 Touch the desired contact entry to create the shortcut on the current Home screen. • Direct Dial: <p>Touch the desired phone number to create the shortcut on the Home screen. You can touch the shortcut to dial the number directly.</p> • Direct Message: <p>Touch the desired phone number to create the shortcut on the Home screen. You can touch the shortcut to compose and send a message to the number.</p>

Items	Steps
Shortcuts	<ul style="list-style-type: none"> • Gmail label: Touch to create a desired Gmail label shortcut so that you can access your e-mails with that label from the Home screen. • Settings: <ol style="list-style-type: none"> 1 Scroll through the settings to locate the desired one. 2 Touch the desired setting to create the shortcut on the current Home screen, where you can touch the shortcut to access the setting.
Widgets	<ol style="list-style-type: none"> 1 Flick through the available applications or services to locate the desired one. 2 Touch the desired widget to add it on the Home screen.
Folders	<p>You can create the following folders:</p> <p>New folder: Add a folder where you can store your Home screen shortcuts.</p> <p>All contacts: Add a shortcut to all your contacts stored in the Contacts application.</p> <p>Contacts with phone numbers: Add a shortcut to the contacts with phone numbers.</p> <p>Starred contacts: Add a shortcut to the contacts marked with a star.</p> <p>Touch the desired folder to create one on the Home screen.</p> <p>Once the folder is on your Home screen, you can drag and drop an item on top of the folder in order to add it to the folder.</p>

Items	Steps
<p>Wallpapers</p> <p>Change the wallpaper of your Home screen.</p> <p>NOTE: You can also touch the Home button  → the Menu button  → Wallpaper to change your Home screen wallpaper.</p>	<ul style="list-style-type: none"> • Photos: Select a picture stored on the device as a wallpaper. <ol style="list-style-type: none"> 1 Flick the picture thumbnails horizontally to locate the desired picture. 2 Touch the picture to display it. 3 To cut a portion of the picture as the wallpaper, move the crop frame and drag the angles to locate the desired part. 4 Touch the check button to set the wallpaper. • Wallpaper gallery: Select a preinstalled wallpaper. <ol style="list-style-type: none"> 1 Flick the wallpaper thumbnails horizontally along the bottom of the screen to locate the desired one. 2 Touch the wallpaper's thumbnail. 3 Touch the Set wallpaper button.

To add an application shortcut to the Home screen from either the main application view or the Favorites bar:

- 1 Touch the Application button  on top of the screen to open the Favorites bar.
- 2 If the main applications menu is not displayed, touch the **More** icon  on the right end of the Favorites bar to open the main applications menu.
- 3 On the main applications view or the Favorites bar, drag a desired application onto the current Home screen, then the application's icon appears on the Home screen.

To move a Home screen item

- 1 Touch and hold the item you want to reposition until it magnifies and becomes movable. The device vibrates to indicate that the item's moving mode is activated.



NOTE: To disable the item's moving mode, touch the item again.

- 2 With your finger remaining in contact with the item on the screen, drag the item to another location on the screen.

- 3 Release the item in the desired location.

To remove a Home screen item

- 1 Touch and hold an item such as a widget, shortcut, or folder that you want to remove, until it magnifies and becomes movable.
- 2 Touch the Menu button  and then touch **Remove from Home**.

To open a Home screen folder

- 1 Touch the folder to open a black panel representing the contents of the folder.
- 2 Touch the desired application shortcut to run the application.

To close a Home screen folder

Touch the folder again to close the black panel.

To move a Home screen shortcut into a folder

- 1 Touch a folder on the Home screen to view the contents.
- 2 Touch and hold a shortcut to make it movable.
- 3 Drag and drop the shortcut into the folder.

 **NOTE:** You can also drag items directly into a folder without opening the folder.



 **NOTE:** Widgets and folders cannot be moved inside a folder.

To remove a Home screen shortcut from a folder

- 1 Touch a folder on the Home screen to view the contents.
- 2 Touch and hold a shortcut to make it movable.
- 3 Drag the shortcut in the folder to another location on the Home screen.

To rename a folder





- 1 Touch and hold the folder until it magnifies.
- 2 Touch the Menu button  and then touch **Rename Folder**.
- 3 Touch the Folder name input field to type the folder name using the on-screen keyboard.

- 4 To close the on-screen keyboard, touch the icon  on the keyboard, or touch and hold the Menu button .
- 5 Touch OK to confirm.

Status Bar





















The status bar displays the application button, title area, date and time, and status area.









-
- | | |
|--|---|
| <p>1 Application button </p> | <p>Touch the application button  to display the applications available on your device:</p> <ul style="list-style-type: none"> – The Favorites bar can be customized to display up to seven preferred or frequently used applications. – The main applications menu contains all of the applications on your device, including those you have downloaded from the Android Market. – Touch an application to run it. <p>NOTE: Touch the More  or Less  icon on the right corner of the Favorites bar to set the option for the application button to open only the Favorites bar, or open both the Favorites bar and the main applications menu.</p> |
| <p>2 Title area</p> | <p>Displays the name of the current application in use.</p> |
| <p>3 Notification area</p> | <ul style="list-style-type: none"> • The Notification area displays notification icons to inform you of missed calls, new messages, e-mail, and so on. • Touch the Notification area to view the notifications listed in arrival time order, and then touch a notification to view the desired message, e-mail, or missed call record. |
-













<p>4 Status area</p>	<ul style="list-style-type: none"> • Displays status icons to show the current state of your device, such as battery power, charging progress, alarms set, network connections, and so on. • Touch the status area to view the information regarding the carrier currently in use, remaining battery charge, and so on. • Touch the status area to view the wireless control menu. You can enable or disable the airplane mode, wireless mode, or Bluetooth mode.
<p>5 Date and time area</p>	<p>Displays the current date and time.</p>

The status area may also display some of the following icons:

 Alarm is set	 3G data network is connected
 Battery status — 100% full	 3G data network is in use
 Battery is low and needs to be charged	 GPRS data network is connected
 Battery is extremely low and needs to be charged immediately	 GPRS data network is in use
 Battery is empty and needs to be charged immediately	 EDGE data network is connected
 Battery is charging	 EDGE data network is in use
 Vibrate mode is enabled	 HSPA data network is connected
 Silent mode is enabled	 HSPA data network is in use
 Signal strength — strong	 Roaming signal strength — strong
 No signal	 Connected to a Wi-Fi network

 Airplane mode is enabled	 No SIM card is inserted
 Bluetooth is enabled	 Ongoing data synchronization
 Connected to a new Bluetooth device	 If the GPS satellites function is enabled, this icon appears when you use Google Maps

The notification area may also display some of the following icons:

 Missed call	 New SMS/MMS
 Call in progress	 New e-mail
 Call on hold	 Upcoming calendar event
 Call forwarding is enabled	 USB cable is connected
 Microphone is on mute	 A Wi-Fi network is found
 The SD card is safe to remove	 Download in progress

Navigating the Applications

You can find applications available on your device in these screen elements:

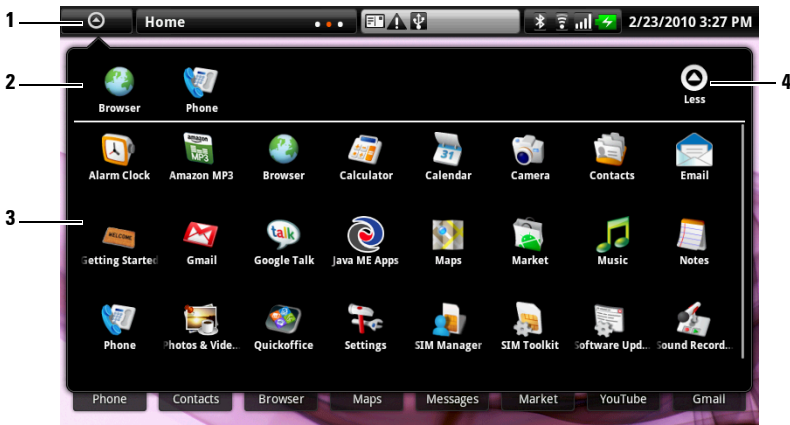

Favorites Bar

You can customize the Favorites bar to include frequently used applications. You can add up to seven applications in the Favorites bar.



- 1 The application button (when the Favorites bar is displayed)
- 2 The Favorites bar
- 3 The main applications menu
- 4 The Less icon (when the main applications menu is displayed)

To add applications to the Favorites bar

- 1 Touch the application button  on top of the screen to open the Favorites bar.
- 2 If the main applications menu is not displayed, touch the **More** icon  on the right end of the Favorites bar to open the main applications menu.
- 3 On the main applications menu, touch and hold the application that you want to add to the Favorites bar.

- 4 Once the application becomes movable, drag and drop it on the Favorites bar.

To remove applications from the Favorites bar

- 1 Touch the application button  on top of the screen to open the Favorites bar.
- 2 On the Favorites bar, touch and hold the application to remove.
- 3 Drag the application out of the Favorites bar.

Application Shortcuts



To quickly launch applications on the Home screen, you can add shortcut icons for frequently-used applications to the Home screen or to the folder that you created on the Home screen. For more information, see *Customizing Your Home Screen*.

To open an application using the application shortcuts

- 1 Touch the Home button .
- 2 If the desired application shortcut displays on the Home screen, touch the shortcut to run the application.
If the desired application is stored in a folder on the Home screen, touch the folder to bring up the black panel to display the contents of the folder, and then touch the desired application shortcut within the black panel.

Recent applications

To open a recently used application

- 1 Touch  or touch and hold the Home button  to view the recently used applications.



NOTE: Recent applications are displayed below the thumbnail views of the Home screens.

- 2 Touch the desired application on the bar to run the application.

Using Your Dell™ Streak

Calling

Making Calls

To make calls, touch  **Phone** on the Home screen to open the Phone application.

To make a call

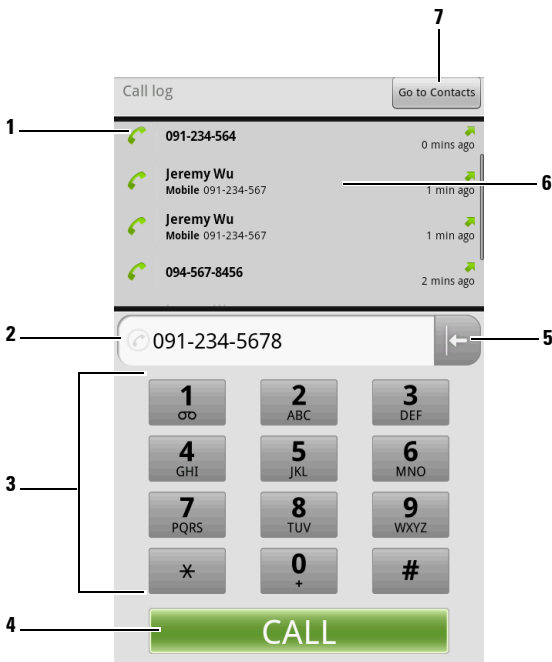

- 1 Touch  to call a desired phone number or contact from the call log.
- 2 Touch the typed number to make a call to the number.
- 3 Type the number to call using the on-screen dialpad.



4	Touch to call the typed number.
5	Touch to clear an incorrect number.
6	Touch a call record to view the call information, call or send a message to the caller, or save or view the caller in Contacts. See Managing Contacts for information about using Contacts.
7	Touch to select a contact to call from Contacts. For more information, see To call, e-mail, or send a message to a contact from your contacts list.

To cancel dialing

Touch  on the Dialing screen to cancel a dialed call.

To manage and redial missed, dialed, and received calls

On the Phone screen, scroll the call log to locate a call displayed either as a phone number or as a contact's name. You can choose to do the following with the call:

- Touch  to call the number or contact.
- Touch the name or number to view the call's details displayed at the top of the options menu.
You can choose to call back, send a text or multimedia message to the caller, add the number as a contact to your Contacts list, or view the contact's details if the caller is already a contact saved in your Contacts list.
- Touch and hold the name or number for more options, such as erase the call from the call log.
- To erase all calls from the call log, touch the Menu button  → Clear call log.



To answer a call

Touch  on the Incoming call screen to answer an incoming call.

To end or reject a call

Touch  on the Dialing screen to end an active call; touch

 on the Incoming call screen to reject an incoming call.

 **NOTE:** Touching the Menu button  → **End call** also ends a call.

To make an international call

- 1 Touch and hold the number 0 key on the dialpad until + appears.
- 2 Enter the country code, area code, and phone number.
- 3 Touch the displayed phone number to make a call.

To listen to your voicemail



Touch and hold the number 1 key on the dialpad to call your voicemail box.

 **NOTE:** If no voicemail number is stored on your SIM card, you will be asked to create one. Touch **Add number** to enter and save your voicemail number.



Manage Your Calls

To hold an active call

Touch  to hold a call in progress. When a call is being held, the on

hold icon  appears in the status bar. To resume a held call, touch .

To mute the microphone during a call

Touch  to turn the microphone on or off. The mute icon  appears in the status bar when the microphone is muted.

To use the speakerphone during a call

 **WARNING:** Ensure that you turn off the speakerphone before you hold the device close to your ear as this could damage your hearing.

Touch  to turn the speakerphone on or off.



To accept calls using a Bluetooth headset

When a Bluetooth headset is connected to your device, you can accept calls



on the Bluetooth headset by touching . For details on how to connect a Bluetooth headset to your device, see Bluetooth®.

To accept a waiting call

If there is an incoming call while you are on another call, the device notifies you with a call waiting tone. The phone number or name of the waiting call is displayed.

- Touch  or touch the Menu button  → **Hold current call & answer** to accept the waiting call and put the active call on hold.
- To end the first call and take the waiting call, touch the Menu button  → **End current call & answer**.



To dial another call during an active call

- Touch the Menu button  → **Add call**. Make the call (see To make a call). The first call is placed on hold automatically.
- Drag  upward to reveal the full dialpad, and type the number using the dialpad. Touch  to call the typed number.



To swap between active and held calls

Touch the Menu button  → **Swap calls** to swap between two calls.

To conduct a conference call

- 1 During a call, touch the Menu button  → **Add call**.
- 2 Make the second call that you want to add to the conference call. The first call is automatically placed on hold.
- 3 When the second call is connected, touch the Menu button  → **Merge calls** to start the conference call.
- 4 To add more participants to the conference call, repeat step 1 to step 3.

5 During a conference call, touch the Menu button  → **Manage conference call** to manage call participants:

- Touch  to drop a selected participant from the conference.
- Touch  to talk to a selected participant in private and place the other participants on hold.
- Touch **Back to call** to rejoin the remaining call participants.





NOTE: To end a conference call and disconnect all participants, touch



Adjust Call Settings

You can change call settings to suit your personal needs, or enable the call services available from your network service provider.

Touch the Home button  → Menu button  → **Settings** → **Call settings**.

Fixed Dialing Numbers (FDN)

Restricts outgoing calls to the phone numbers on the FDN list. To enable this service, you need to enter your SIM card's PIN2 that you can obtain from your network service provider.

Voicemail

Stores another voicemail number other than the one already on your SIM card.

Additional call settings

- **Call forwarding:** Diverts incoming calls to a designated phone number when your device is busy, unreachable, or does not answer.

To enable call forwarding, enter the number to divert to

or touch  to select a contact from your Contacts list. Then touch **Enable**.

NOTE: Your network service provider must support the call forwarding service.

- **Call barring:** Blocks certain types of incoming or outgoing calls.
- **Caller ID:** Shows the caller id or number on the display based on the setting.

NOTE: Your network service provider must support this service.

- **Call waiting:** Alerts an incoming call with a call waiting tone or message when you are on another call.

NOTE: To use call waiting, you may need to register this service with your service provider.

- **Auto Answer:** Sets how long your device waits before automatically answering an incoming call.

Teletypewriter (TTY) mode

Enable this mode to let the user with speech or hearing disabilities conduct phone conversations by typing.



Hearing Aid Compatible (HAC) mode

Enable this mode to minimize interference from the device with the user's hearing aid, and optimize audio output for the hearing aid.

NOTE: Enabling the HAC mode will disable the Bluetooth and Wi-Fi transmitter functions.

Text Messages

To compose, send, and read text (SMS) or multimedia (MMS) messages,

touch  →  **Text Messages**. The Text Messages screen opens with a list of messages or message threads representing all the received, sent and draft messages.

 **NOTE:** For information about the message thread, see [Receiving text and multimedia messages](#).



To compose and send a text message

- 1 On the Text Messages screen, touch the **New message** thread. The composer screen opens.
- 2 In the **To** field, type the mobile phone number or the contact name of the recipient. As you type a phone number or contact name, matching contacts with their mobile numbers appear below the **To** field. Touch a matched contact to enter the contact's mobile number, or continue typing the desired phone number.
- 3 Repeat step 2 to enter more mobile numbers if you wish to send the message to multiple mobile phone users.
- 4 You can add a subject line to the message by touching the Menu button  → **Add subject**.

 **NOTE:** When adding a subject, the message automatically changes to the MMS format.

- 5 Touch the **Type to compose** text field to start composing your message.
- 6 Touch the **Send** button to send the text message.
- 7 To start a text conversation similar to online instant messaging, you can continue to compose and send messages to the same recipient(s). All of the sent and received messages between you and recipient(s) appear in the form of chat logs.

To compose and send a multimedia message

- 1 In the **To** field, type the recipient's mobile phone number, e-mail address, or contact name. Matching contacts with their mobile numbers or e-mail addresses appear below the **To** field. Touch a matched contact, or continue manually typing the desired phone number or e-mail address.
- 2 Repeat step 1 to enter more mobile numbers if you wish to send the message to multiple mobile phone users.
- 3 You can add a subject line to the message by touching the Menu button  → **Add subject**.
- 4 Touch the **Type to compose** text field to start composing your message.
- 5 While editing your message, you can touch the Menu button  → **Attach** to insert media items into the message (see below).
- 6 When you have completed editing the multimedia message, touch the **Send** button to send the message.

You can attach any of the following items to a multimedia message:

Picture	Open the Photos & Videos application and touch a picture file to attach it to your message.
Capture picture	Open the Camera application to take a picture, then attach it to your message. For details about the Camera application, see Camera.
Video	Open the Photos & Videos application and touch a video clip to attach it to your message.
Capture video	Open the Camera application to take a video clip, then attach it to your message. For more information about the Camcorder application, see Camera.

Audio



Open the **Select audio** menu. Touch a desired audio file, and then touch **OK** to attach the file to your message.

To attach an audio file stored on the SD card to MMS:

- 1** Create a folder named Ringtones in the SD card.
 - 2** Open the Ringtones folder.
 - 3** Copy the audio file you want to attach to MMS into the Ringtones folder.
 - 4** On the MMS composer screen, touch the Menu button  → **Attach** → **Audio**.
 - 5** Select the audio file to attach it to the MMS.
-

Record audio



Open the **Recorder** application to record an audio clip.

- Touch  to start recording.
 - Touch  to stop recording.
 - Touch  to listen to the recording.
 - Touch **Use this recording** to attach the recording to your message.
-



Slideshow

Open the **Edit slideshow** screen to create a slide show and attach it to your message.

- 1 Touch **Add slide** to create new slides.
- 2 Touch a created slide such as **Slide 1** to open the slideshow editor screen.
- 3 Touch **Add picture**, and then select the picture you want to add to the slide.
- 4 You can touch the text field on the lower part of the screen to compose a caption for the displayed slide.
- 5 Touch the Menu button  to preview the slide, remove the picture, add a music to the current slide, add a new slide, or change the slide duration or the text and picture layout.

- 6 When editing multiple slides, touch  to edit the next slide; touch  to return to the previous slide.

NOTE: You can create a slideshow of up to ten slides.

- 7 To replace a picture, on the slideshow editor screen, touch the **Replace picture** button and select a new one to replace. To remove the current slide, touch the **Remove Slide** button. To preview the slideshow, touch the **Preview** button.
 - 8 When complete, touch the **Done** button at the bottom right to attach the slideshow to your message.
 - 9 On the message composer screen, touch the slideshow attachment icon  to playback the slide show; touch **Edit** to modify the slideshow.
 - 10 To remove the slideshow attachment from your message, touch **Edit**→ the Menu button  → **Discard slideshow**.
-

Receiving text and multimedia messages

Depending on your notification settings, the device rings, vibrates, or displays a message briefly in the status bar as a new text or multimedia message arrives.



A new message icon  then appears and stays in the notifications area of the status bar to remind you of a new message.



NOTE: To alter notification settings for new messages, in the **Text Messages** application touch the Menu button  → **Settings** → **Notifications**. You can then decide whether to receive a text notification in the status bar when a new message arrives, select a ringtone that rings with the arrival of a new message, or let the device vibrate to report a new message.

Text and multimedia messages that are sent to and received from the same contact or a number are grouped into message threads similar to text conversations of an online chat. You can see all of the messages exchanged between you and the contact. Message threads are listed according to when they are sent or received, with the latest one at the top.

To read a text message

- Touch the notification area on the status bar where the new message icon  is displayed. A list of notifications opens. Touch a new message notification to open and read the message.
- Touch  →  **Text Messages** to open the message list, and then touch a text message or message thread to open and read it.

If the message contains:

- Web site—touch the link to open the **Browser** application and visit the web site.
- Phone number—touch the number to open the **Phone** application and call the number.
- E-mail address—touch the e-mail address to open the **Email\Gmail** application and compose an e-mail to send to the address.



To forward the message

- 1 Touch and hold the message. The **Message options** menu pops up.
- 2 Select **Forward** to forward the message.

To view a multimedia message

- 1 Touch the notification area on the status bar where the new message icon  is displayed. A list of notifications opens. Touch a new message notification to open the message.

Or

Touch  →  **Text Messages** to open the message list, and then touch a multimedia message or message thread to open the message.

- 2 Touch the thumbnail of the attached picture to display the picture; touch the **Play** button  to play back the attached video.



NOTE: Touch the **Download** button, to manually download the media file in the message.





NOTE: To save the attached media item to your microSD card, touch and hold the message and the **Message options** menu pops open. Touch **Copy attached to SD card**.

To reply to a text or multimedia message

- 1 Touch a message or message thread to open it.
- 2 Type your reply message into the text field.
- 3 Touch **Send** to send your message to the sender.

To delete a message or a message thread

- 1 In the Text Messages list, touch and hold the message thread that you want to delete.
- 2 To delete the entire thread, touch **Delete thread** and then touch **OK** to confirm deletion.
To delete a message within a thread, touch and hold the message to delete, and then touch **Delete message** on the Message options menu. Touch **OK** to confirm deletion.

 **NOTE:** To delete all messages on the message list, touch the Menu button  → **Delete threads.**



To edit message settings

In the message list, touch the Menu button  → **Settings** to change the text or multimedia message settings. Follow the instructions on the screen.

Pop-Up Menu

Touch the Menu button  to open or close the pop-up menu that lists available options for the current application, or actions that you can perform on the current screen.



To select an option or item on the pop-up menu

- 1 Touch the Menu button  to open the pop-up menu.
- 2 Touch the desired item on the pop-up menu.
- 3 If the menu has a scroll bar on the right side, you can flick the menu until the desired item is found.
- 4 Touch the Menu button  again to close the pop-up menu.

On-Screen Keyboard

You can type text using the on-screen keyboard. When you start an application or touch a field that requires text input, the on-screen keyboard opens. The keyboard automatically rotates to either the portrait or landscape mode based on the device orientation.

To close the keyboard



Touch the Back button  or the icon  on the keyboard, or touch and hold the Menu button .

To display the keyboard



Touch and hold the Menu button  or touch a text field.





Keyboard controls



- 1
 - Touch to type letters into the field where the cursor appears.
 - Touch and hold to type accented letters for applicable languages.
- 2
 - Based on the letters being typed, the keyboard shows suggested words along the top, the most probable one highlighted in color.
 - You can touch a suggested word to enter it into the text field.
- 3
 - Touch to show the uppercase keyboard for typing an uppercase letter.
 - Touch to change back to the lowercase keyboard.
- 4
 - Touch  to move the cursor to the left; touch  to move the cursor to the right.
- 5
 - Touch to show the symbol keyboard for typing punctuation marks and symbols other than the period.
 - Touch to switch back to the alphabet keyboard.
- 6
 - Touch to type the smiley ":-)".
 - Touch and hold to see more emoticons available for typing.
- 7
 - Touch to delete a typed character, symbol, or a space.
 - Touch and hold to quickly delete typed text.
- 8
 - Touch to see more suggested words.

To configure the keyboard settings

- 1 Touch the Home button  → the Menu button  → Settings → Locale & text → Android keyboard, or

touch the Application button  → the Settings icon  → Locale & text → Android keyboard.
- 2 To enable a setting, touch the setting option to select the check box  ;
to disable a setting, touch the setting option to clear the check box .



Available keyboard settings



Vibrate on keypress	The device vibrates when you touch a key.
Sound on keypress	The device beeps when you touch a key.
Auto-capitalization	The first letter of the word in a new sentence is capitalized.
Show suggestions	Show suggested words as you type.
Quick fixes	Mark and correct wrong spellings and typos.
Auto-complete	A space or a proper punctuation mark is automatically inserted after a typed word.

Create your personal dictionary

The keyboard uses the default dictionary to display suggested words as you type. You can create a personal dictionary to include words not found in the main dictionary. The keyboard will also look at the words that are added to your personal dictionary to make word suggestions.



To add a word to the dictionary



- 1 Touch the Home button  → the Menu button  → Settings → Locale & text → User dictionary, or

touch the Application button  → the Settings icon  → Locale & text → User dictionary.
- 2 Touch the Menu button  → Add.



- 3 Type a desired word into the **Add to dictionary** text field.
- 4 Touch **OK**.



To edit a word in the dictionary

- 1 Touch Home button  → the Menu button  → **Settings** → **Locale & text** → **User dictionary**, or

touch the Application button  → the **Settings** icon  → **Locale & text** → **User dictionary**.
- 2 Touch a desired word.
- 3 Touch **Edit**.
- 4 Edit the spelling of the word in the **Edit word** text field.
- 5 Touch **OK**.

To delete a word from the dictionary

- 1 Touch Home button  → the Menu button  → **Settings** → **Locale & text** → **User dictionary**, or

touch the Application button  → **Settings** icon  → **Locale & text** → **User dictionary**.
- 2 Touch the word to delete.
- 3 Touch **Delete**.

Widgets



NOTE: To use the following widgets, you need to create them on the Home screen of your device, and have a data network connection to be able to connect to the web. For information on configuring the web see [Connecting to the Web](#). For information on adding widgets to the Home screen see [Customizing Your Home Screen](#).

Google Search

You can use the Google Quick Search Box to find websites and information on Google, or access applications installed on your device.

To search by typing

- 1 On the Home screen of your device, touch the **Google Quick Search Box**. The on-screen keyboard opens.
- 2 Type a keyword or full name into the box using the keyboard. As you are typing, the search results that fully or partially match the text being typed appear below the search box.
- 3 Scroll the listed search results and touch to select a desired one. If you only want to view matching web links on Google, either touch the **Search** key on the keyboard or the search icon  on the search box.
- 4 The matching application or the browser with matching web links opens.
- 5 Touch a desired link if you want to view a web page.

To search by voice

- 1 Touch  on the right corner of the search box.
- 2 Say the name or keyword of the item you are looking for.
- 3 The browser with matching web links opens.

RSS

Real Simple Syndication (RSS) is a web format for website owners to publish RSS feeds—full or summarized texts of frequently updated web contents such as blog entries and news headlines.

After you subscribe to an RSS feed, you will receive an update once the RSS publisher releases new content. You can then use your device's RSS reader to read RSS feeds that you have subscribed to.

To find your RSS feed's URL

- 1 Touch **Browser**  to open the browser.
- 2 Go to the website that provides the RSS feed you want.
- 3 Touch the orange RSS icon next to the RSS feed. The RSS feed URL is then displayed in the web address field at the top of the browser screen.
- 4 Touch the web address field, and then touch and hold the web address field to open the **Edit text** pop-up menu.
- 5 Touch **Copy all** to copy the displayed URL.
- 6 Return to the RSS Feed widget on the Home screen.

To subscribe to RSS feeds

Enter a RSS feed URL into the RSS reader:

- 1 On the RSS Feed widget, touch **Configure**.
- 2 Type or paste your RSS feed's URL that you have copied from the browser.
- 3 Touch **Set**.

To read RSS feeds

Touch the RSS Feed widget to open the RSS reader. A list of RSS channels appears. Touch a channel to read the RSS feeds inside.

Your device's RSS reader checks your subscribed feeds regularly and downloads updates that it finds from those feeds.



NOTE: Some RSS publishers may require a payment for downloading RSS feeds.

Facebook

Facebook is a social networking website where you can post your personal profile, find and contact your friends, classmates or work associates, and exchange messages with them.

- 1 On the Home screen of your device, touch the **Sign in** button at the top right of the Facebook widget.
- 2 To use Facebook, you need to create a Facebook account if you do not have one. Touch the **Sign Up** button and follow the instructions to proceed.
- 3 To sign in to Facebook, type your e-mail and password and touch **Login**.



NOTE: For information on using Facebook, visit facebook.com/help.

Twitter



Twitter is a social networking service application that allows you to keep in touch with people on the web by posting simple questions and answers.

- 1 On the Home screen of your device, touch the **Sign in** button at the top right of the Twitter widget.
- 2 To use Twitter, you need to create a Twitter account if you do not have one. Touch the **Get started** button and follow the instructions to proceed.
- 3 To sign in to Twitter, type your user name or e-mail address and your password, and then touch **Sign in**.





NOTE: For information on how to use Twitter, visit [Twitter.com/Help](https://twitter.com/Help).



Managing Contacts

To view and manage your contacts, touch the Application button  →  **Contacts**.



NOTE: If you have signed in to your Google account and have selected **Auto-sync** and **Contacts** from: Home button  → the Menu button  → **Settings** → **Data synchronization**, your Google contacts will be automatically added to your Contacts list.

To add a new contact

- 1 Touch the Menu button  → **New contact**.
- 2 Enter the contact information using the on-screen keyboard. Scroll the screen to find more items to fill.
- 3 When you have entered all the required information, touch either the **Save** button on the upper right or touch the Menu button  → **Save** to save the contact.

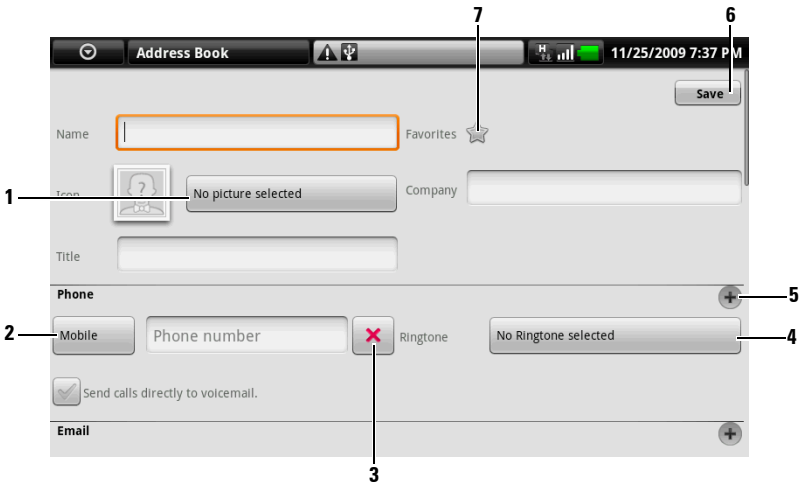





While entering the contact details, you can:

- 1 Touch and select a photo from the Photos & Videos application to use as the contact's visual caller ID.
- 2 Touch to replace a default information label with another one that you choose from the **Select label** list, for example from **Mobile** phone number to **Home** phone number. To create a new information label for the current item, you can flick down to the end of the **Select label** list and touch **Custom**.
- 3 Touch to remove an item from the current information category.
- 4 Touch to select a ringtone for the contact's incoming calls.
- 5 Touch to add a new item to the current information category, for example a second phone number.
- 6 Touch to save the new contact to your **Contacts list**.
- 7 Touch to star the contact as a favorite.

To view the contact details

- 1 To locate a contact, you can either:
 - Flick the contact list until you find the contact.
 - Touch an alphabet displayed on the top that matches the first letter of the contact's first or last name. The screen then displays the contacts whose first or last names starts with the selected alphabet.
 - Touch the **Search** button at the upper right of the screen, and then type either the contact's full name or only the first letters of it into the **Search For** text field. The screen then displays the matching contacts.
 - Touch the contact group tab on the upper left of the screen, and then touch the desired group, **Family**, for example. The screen shows the contacts within that group.
- 2 Once the contact is located, touch the contact's entry to view the contact's details.

To call, e-mail, or send a message to a contact from your contacts list



- 1 Locate the desired contact's entry on the contact list.
- 2 Select the action you want to do by touching a corresponding icon:
 - To call the contact, touch .
 - To send text or multimedia message to the contact, touch .
 - To e-mail the contact, touch .
 - To start an instant messaging chat with the contact, such as on Google Talk, touch .
- 3 If the contact has multiple phone numbers, e-mail addresses or instant messaging accounts, and you want to find out which one to use:
 - a Touch the contact's entry to open the contact information screen.
 - b Touch a corresponding icon that immediately follows the desired phone number, e-mail address or instant messaging account.



NOTE: For information about composing and sending SMS and MMS, see Text Messages. To find out how to start an instant messaging chat on Google Talk, see Google Talk. For information about using the e-mail applications, see Gmail and E-mail.



To add contacts from your SIM card

You can copy contacts saved on your SIM card to your device's Contacts.



- 1 In the contact list, touch the Menu button  → **Import contacts**.
- 2 Touch the contact to add to the device, or touch the Menu button  → **Import all** to copy all the contacts to the device.

Managing Your Device Settings



To check storage spaces

Touch the Home button  → Menu button  → **Settings** → **SD card & device storage**. The screen displays total and available spaces on the device and on the microSD card.

To erase unwanted application data to free storage space

- 1 Touch the Home button  → Menu button  → **Settings** → **Applications** → **Manage applications**.
- 2 From the Manage applications list, touch the application whose cache or data you want to remove.
- 3 In the Application info screen, touch **Clear data** under **Storage** to erase unwanted application data; touch **Clear cache** under **Cache** to erase unwanted cache.

To format the microSD card

- 1 Touch the Home button  → Menu button  → **Settings** → **SD card & device storage**.
- 2 Touch **Unmount SD card** to enable the **Format SD card** option.





CAUTION: Formatting a microSD card erases all data and downloaded applications store on it. Ensure that you back up the data that you need before formatting your microSD card.

- 3 Touch **Format SD card** → **Format SD card** button.

To erase all data from your device

 **CAUTION:** The following steps will erase all the data including your Google account and downloaded applications from your device. Ensure that you back up all the required data before you proceed.





- 1 Touch the Home button  → Menu button  → Settings → Privacy → Factory data reset.
- 2 Touch Reset device.

 **NOTE:** You need to draw your screen unlock pattern if it is enabled.

- 3 Touch Erase everything after you read the warning.

To reset your device to the default state

 **CAUTION:** The following steps will restore your device to the default state and erase all data and downloaded applications stored on it. Ensure that you back up all the required data before you reset the device.

- 1 Press and hold the power button  and then touch the Power off option on the screen to turn off the device.
- 2 Simultaneously press and hold the volume up button  and volume down button .
- 3 Without releasing the volume buttons, press and hold the power button, until the device turns on the configuration screen.
- 4 Press the volume buttons to move the highlight bar on the screen to the Factory reset option.
- 5 Touch the Camera button  to start the reset process.
- 6 Wait for the device to reboot.

To upgrade the software version on your device

- 1 Follow steps 1 to 3 in To reset your device to the default state to turn on the configuration screen.
- 2 Press the volume buttons to move the highlight bar on the screen to the Software upgrade from Update.zip option.
- 3 Touch the Camera button  to confirm the action.

Web

Connecting to the Web

To browse the web and access web-based utilities such as instant messaging, one of these data networking connections must be available:





- GPRS
- EDGE
- 3G
- HSPA
- Wi-Fi

GPRS/EDGE/3G/HSPA

To connect to the web using GPRS, EDGE, 3G, or HSPA

Your device is configured with GPRS, EDGE, 3G, or HSPA network available with the service provider of the SIM card installed in your device. However, this is only limited to voice calling and text messaging. If a Wi-Fi connection is currently available, the device automatically uses the Wi-Fi connection to access the web. The web connection through GPRS, EDGE, 3G, or HSPA becomes temporarily inactive, until the Wi-Fi connection ends.

If you wish to connect to the web using a GPRS, EDGE, 3G, or HSPA data network:

- 1 Touch the Home button  → Menu button  → **Settings** → **Wireless controls**, then touch **Wi-Fi** to disable it.
- 2 Touch the Home button  → Menu button  → **Settings** → **Wireless controls** → **Mobile networks**, then touch **Data connection** to enable it.



 **NOTE:** For quick access to wireless controls, touch the status bar as shown in the figure below to perform the same settings.





 **NOTE:** Depending on whether a GPRS, EDGE, 3G, or HSPA network is currently in use, a corresponding data network icon appears on the status bar after a data connection is established. See [Status Bar](#) on [Status Bar](#) for a mapping of the data network icons.

You can set the device to search for available networks if you are outside your home network or want to register to a different network.

To manually select a new network

- 1 Touch the Home button  → Menu button  → Settings → Wireless controls → Mobile networks → Network operators → Search networks. The list of networks currently available is displayed.
- 2 Select a network manually from the network list.

To automatically select a new network

Touch the Home button  → Menu button  → Settings → Wireless controls → Mobile networks → Network operators → Select automatically.



Wi-Fi

You can connect your device to the Internet using Wi-Fi.

To use Wi-Fi on your device, you need access to a wireless point or "hotspot" within a distance of up to 300 feet (100 meters).

 **NOTE:** The range and quality of the Wi-Fi signal is affected by the number of connected devices, infrastructure, and objects through which the signal passes.

To turn on Wi-Fi and connect to a network

- 1 Touch the Home button  → Menu button  → **Settings** → **Wireless controls** → **Wi-Fi** to select the Wi-Fi check box. The device scans for available wireless networks.
- 2 Touch **Wi-Fi settings**. The network names and security settings (**Open network** or **Secured with WEP/WPA/WPA2/WPS**) of discovered Wi-Fi networks display in the **Wi-Fi networks** list.
- 3 Flick the list and touch to select a Wi-Fi network to connect to.
- 4 Touch **Connect** to confirm connection.

 **NOTE:** To connect to a network protected by Wired Equivalent Privacy (WEP), WPA (Wi-Fi Protected Access), WPA2, or WPS (Wireless Protected Setup), you must enter the WEP/WPA/WPA2/WPS security key to obtain authorized access to the network. The next time your device connects to a previously accessed secured wireless network, you will not be asked to enter the WEP/WPA/WPA2/WPS key again, unless you reset your device to its factory default settings.

 **NOTE:** Your device has the ability to maintain a constant web connection through Wi-Fi or mobile networks (GPRS, EDGE, 3G, or HSPA). However, Wi-Fi connection has priority over mobile network connection if both are available.



To check the current Wi-Fi network connection

From the status bar:

When your device is connected to a wireless network, the Wi-Fi icon  in the status bar indicates the signal strength (number of bands that light up). If



Wi-Fi settings → **Network notification** is enabled, this icon  appears in the status bar as the device discovers an accessible Wi-Fi network within range.



From the Wi-Fi network:

- 1 Touch the Home button  → Menu button  → Settings → Wireless controls → Wi-Fi settings.
- 2 Touch the Wi-Fi network that the device is currently connected to (labeled **Connected**). A window opens displaying the Wi-Fi network's name, status, speed, signal strength, security info, and IP address.

 **NOTE:** If you want to disconnect the Wi-Fi network from your device, touch **Forget** on this window. You will need to configure the Wi-Fi settings again if you want to restore connection to this wireless network.

To connect to another Wi-Fi network

- 1 Touch the Home button  → Menu button  → Settings → Wireless controls → Wi-Fi settings. Detected Wi-Fi networks are displayed in the Wi-Fi networks list.



 **NOTE:** To start a new search for available Wi-Fi networks, on the **Wi-Fi settings** screen, touch the Menu button  → **Scan**.

- 2 Flick through the Wi-Fi networks list and touch the name of the network you would like to connect to.

 **NOTE:** If the wireless network you want to connect to is not in the list of detected networks, flick to the bottom of the list to touch **Add Wi-Fi network**. Enter the Wi-Fi network settings, and then touch **Save**.

Disable all Connections Using the Airplane Mode

Selecting the Airplane mode disables all mobile and Wi-Fi connections. This feature is useful when wireless connectivity is strictly prohibited, such as on an airplane.

Touch the Home button  → Menu button  → Settings → Wireless controls → Airplane mode to enable or disable the Airplane mode.

 **NOTE:** You cannot charge the device when it is in Airplane mode.

Browsing the Web

To open the browser

Touch **Browser** .

To use the browser controls bar

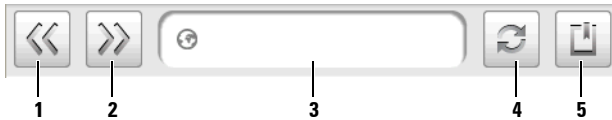

-
- 1 Touch to view the previous page.

 - 2 Touch to view the next page.

 - 3 Touch the web page address field and type the address of the web page you want to go to.

 - 4 Touch to refresh the current page.

 - 5 Touch to show bookmarks or add the current web page to the bookmark list.
-

To go to a web page

- 1 On the browser screen,
 - Touch the web page address field on the screen.
 - Touch the Menu button  → **Go**.
- 2 Type the web page address using the on-screen keyboard. As you type the address, matching web page addresses appear.
- 3 Touch an address displayed on the screen to go directly to that web page, or complete typing the web page address, then touch **Go**.

To set up your home page

- 1 Touch the Menu button  → **Settings** → **Set home page**.
- 2 Enter the web address of the web site you want to use as your home page and then touch **OK**.

Viewing Web Pages

To navigate on a web page

Flick your finger horizontally or vertically on the screen to scroll and view desired areas of a web page.

To zoom in on a web page

Pinch-out a desired area of a web page by moving two fingers apart on the screen.

To zoom out on a web page

Pinch-in a desired area of a web page by bringing two fingers closer together on the screen.

To open a new window



If there is only one active window, touch the Menu button  → **New window**. A new browser window opens and leads you to the home page.

If there are several active windows:

- 1 Touch the Menu button  → **Window overview**. The **Current windows** screen opens to display multiple browser windows in a smaller view.
- 2 Flick to the **New window** browser window and then touch it. A new browser window opens and takes you to the home page.

To switch between browser windows

You can open multiple browser windows to easily switch from one web page to another.

- 1 On a browser window, touch the Menu button  → **Window overview**. The **Current windows** screen opens to display multiple browser windows in a smaller view.
- 2 Touch a browser window with the web page you want to view. The window is then displayed in full screen.
- 3 To close a browser window, touch  on the browser window.



NOTE: You can touch the Title area on the status bar to quickly add or select browser windows. See Status Bar for information on the Title area.

To find text within a web page

- 1 When viewing a web page, touch the Menu button  → **Find on page**.
- 2 Type the search item into the search bar.
- 3 Touch the left or right arrow to go to the previous or next matching item.



NOTE: Touch  to close the search bar.

To copy text on a web page

You can copy and paste text from a web page to your e-mail, text, or multimedia messages.

- 1 Go to the web page from where you want copy the text.
- 2 Locate the text you want to copy and then touch the Menu button  → **Select text**.
- 3 Position your finger at the start of the text you want to copy and then drag to the end of the text you want to copy. The copied text is highlighted in pink.
- 4 Release your finger from the screen.
- 5 To paste text on an e-mail, text, or multimedia message, touch and hold the text field on a message or e-mail screen and then touch **Paste** on the pop menu.

Using Web Links, History, and Downloads



To select a link on a web page

Move to a link you want on a web page. The link is framed by an orange box when you touch it.

Link type	Functionality
Web page address	<ul style="list-style-type: none"> • Touch the link to open the web page. • Touch and hold the link to open a pop-up menu that allows you to open, bookmark, save, copy to the clipboard, or share the link through text messaging.

Link type	Functionality
E-mail address	<ul style="list-style-type: none"> • Touch to send an e-mail to the e-mail address. • Touch and hold till a pop-up menu appears. Touch Copy to copy the e-mail address to the clipboard. You can paste the e-mail address later to a new contact or while composing a new e-mail.
Phone number	<p>Touch to open the Phone application to call the phone number.</p> <p>NOTE: You can call a number from the web page only if the feature is supported by your service provider.</p>

To check the history of visited web pages



- 1 On the browser screen, touch  or touch the Menu button  → **Bookmarks**.
- 2 Touch the **History** tab.
- 3 Touch the day when your desired web page was last visited.
- 4 Touch a web address to open the web page.

 **NOTE:** To check your most visited web pages, touch the **Most visited** tab.

To allow download of web applications

 **CAUTION:** Applications downloaded from the web can be from unknown sources. To protect your device and personal data, download applications only from trusted sources such as **Android Market**.

To download web applications, enable your device's downloading feature.

- 1 Touch the Home button  → Menu button  → **Settings** → **Applications**.
- 2 Touch **Unknown sources** to select the check box.
- 3 When the **Attention** dialog box opens, touch **OK**.

 **NOTE:** All downloaded applications are saved to the microSD card. Before you download an application from the web, ensure that you have installed a microSD card on your device. For information on how to install a microSD card, see **Install the microSD card**.

To install an application

- 1 On the browser screen, touch the application you want to download.
- 2 The application details screen opens. Read details about the application, such as its cost, overall rating, comments by users, the developer contact info, and more.
- 3 To install the application, select either **Install** if item is free or **Buy** if it requires purchase.



To check downloads

On the browser screen, touch the Menu button  → **Downloads**.



Manage Bookmarks

You can store as many bookmarks as you want on your device.



To bookmark a web page

- 1 On the browser screen, go to the web page you want to bookmark.
- 2 Touch  or touch the Menu button  → **Bookmarks**. The **Bookmarks** window opens.
- 3 On the **Bookmarks** tab, touch **Add bookmark...**
- 4 Enter the bookmark name or edit the web address as needed.
- 5 Touch **OK** to save the web page as a bookmark.

To open a bookmark

- 1 On the browser screen, touch  or touch the Menu button  → **Bookmarks**. The **Bookmarks** window opens.
- 2 On the **Bookmarks** window, you can either:
 - Touch the bookmark you want to open in the same browser window.
 - Touch and hold the bookmark you want to open, then on the pop-up menu touch **Open** to open the bookmark in the same browser window, or **Open in new window** to open the bookmark on a new window.

To manage your bookmarks

- 1 On the browser window, touch  or touch the Menu button  → **Bookmarks**.
- 2 On the **Bookmarks** window, touch and hold a desired bookmark to open a pop-up menu that provides the following options:

Edit bookmark	Touch to open the Edit bookmark window. Enter the bookmark's name and address and touch OK .
Add shortcut to Home	Touch to create the bookmark's shortcut on the current Home screen. Then you can touch the shortcut on the Home screen to start the browser and go directly to the bookmarked page.
Share link	Touch to open the message composer with the bookmark's address automatically pasted on the text field. Then send the bookmark's address to others with a text message.
Delete bookmark	Touch to delete the selected bookmark.



To configure browser settings

On the browser screen, touch the Menu button  → **Settings** to adjust the browser settings.

E-mail

You can create POP3, IMAP, and exchange e-mail accounts from web-based e-mail services on your device.

To open the e-mail application

Touch the Application button  → **Email** .

To set up an e-mail account

- 1 On the **Accounts** screen, touch **Next**.
- 2 Type the e-mail address and password of the e-mail account you want to add and then touch **Next**.





 **NOTE:** If the e-mail account you want to set up is not in the device e-mail database, you will be asked to manually enter the e-mail account settings, including the e-mail server, protocol, and so on after touching **Next**.



 **NOTE:** Touch **Manual setup** rather than **Next** to directly enter incoming and outgoing settings for the account being set up.

- 3 Enter the name for the account and the name you want displayed in outgoing e-mails and then touch **Done**.

After creating one e-mail account, touch the Menu button  → **Add account** if you need to create another e-mail account.

To compose and send e-mails



- 1 Touch the Application button  → **Email** .
- 2 In an e-mail account inbox, touch the Menu button  → **Compose**.
- 3 Type the recipient's e-mail address in the **To** field. As you type information, matching contacts appear on the screen. Touch the recipient to automatically add the e-mail address, or continue typing the e-mail address manually. If you are sending the e-mail to multiple recipients, separate their e-mail addresses with a comma. You can add as many recipients as you need.
- 4 Type the subject.
- 5 Compose your message.
- 6 Touch the Menu button  → **Send**.

 **NOTE:** If you want to save the message as a draft and modify it later, touch  or touch the Menu button  → **Save as draft**, and then select **yes**.

To delete an e-mail

- 1 On the e-mail account inbox, touch and hold the e-mail you want to delete.
- 2 On the pop-up menu, touch **Delete**.

To delete or edit an e-mail account on your device

- 1 Touch the Application button  → Email .
- 2 To delete an e-mail account, touch and hold the account you want to remove, then touch **Remove account** on the popup menu. When asked to confirm deletion, touch **OK**.
- 3 To edit an e-mail account, touch and hold the account you want to edit, then touch **Account settings** on the popup menu.



Web Applications

 **NOTE:** You require an active Wi-Fi or mobile data network connection (GPRS, EDGE, 3G, or HSPA) to be able to connect to the web. For more information about configuring your device for web connectivity, see [Connecting to the Web](#).

Gmail

Gmail is a web-based e-mail service provided by Google.

To open Gmail

Touch the Application button  →  Gmail.

To set up your Google account

You need to sign in to a Google account to use Google applications and services such as Gmail, Google Talk, and Android Market. Signing in to your Google account also synchronizes all e-mails and contacts on your Google account with your device.

 **NOTE:** You will not be required to sign in with your Google account if you have already done this when previously using an application that requires signing in to your Google account.

- 1 On the **Set up your Google account** screen, touch the **Next** button to proceed.
- 2 Touch the **Sign in** button. Enter your Google user name and password, then touch the **Sign in** button.

 **NOTE:** If you need to use a different Google user name and password with your device, it will be necessary to erase all data from your device by performing a Factory Reset (see To erase all data from your device).

 **NOTE:** Signing in to your Google Account requires an Internet connection. Ensure that your device has an active Wi-Fi or mobile data connection (GPRS, EDGE, 3G, or HSPA) before you sign in. See Connecting to the Web for more information on how to set up a data connection.

 **NOTE:** Touch the **Create** button if you do not have a Google Account.

Your Gmail inbox opens as the default Gmail view. All your received e-mails are delivered to your inbox.

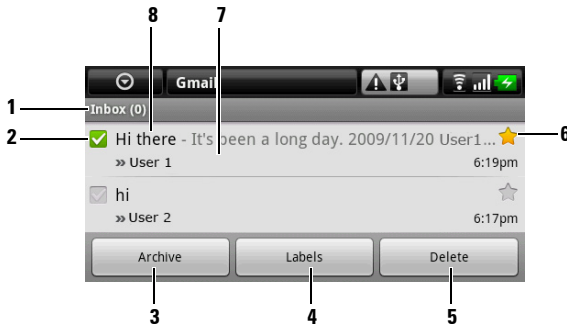

-
- 1 Folder (or Label) and number of unread e-mails.

 - 2 Touch the check box to select the e-mail. To use this feature, touch the Menu button  → **Settings**, then enable **Batch operations**.

 - 3 Touch to store the selected e-mail in the All Mail folder.

 - 4 Touch to label the selected e-mail.

 - 5 Touch to delete the selected e-mail.

 - 6 Starred e-mail. Touch the star to add or remove the star.

 - 7 The number of e-mails grouped under the same subject.

 - 8 Subject.

To refresh Gmail

Touch the Menu button  → **Refresh** to send or receive e-mails and to synchronize your e-mails with your Gmail account on the web.

To view e-mails in different folders or with labels

To view e-mails stored in the folders other than the inbox, such as in the Sent or All Mail folders, or to view labeled or starred e-mails:

- 1 Touch the Menu button  → View Labels.
- 2 Touch the folder that stores the e-mails you want to view, or touch the label with which the e-mails are marked.



To read e-mails

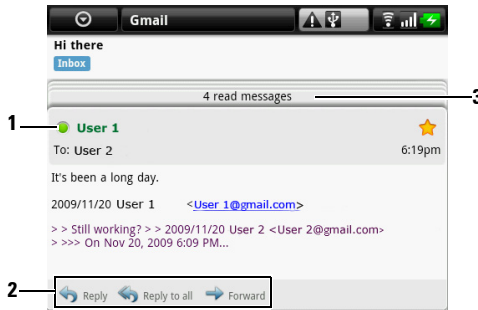

- When you receive a new e-mail, the e-mail icon  appears on the status bar to alert you of a new e-mail. Touch the notifications area of the status bar to open the Notifications panel and touch the new e-mail to view it.
- While in the inbox or in any other folder, scroll the e-mail list on the screen, and then touch an e-mail to open it.



- 1 The green dot indicates that a contact is available on Google Talk.
- 2 Touch to reply to the contact, reply to all contacts in the mail loop, or forward the e-mail to another contact.
- 3 Touch to view previous e-mails with the same subject.

To create and send an e-mail



- 1 Touch the Menu button  → Compose.
- 2 Enter the contact's e-mail address in the To field. To send e-mail to multiple contacts, separate their e-mail addresses with a comma. To send a carbon copy (Cc) or a blind carbon copy (Bcc), touch the Menu button  → Add Cc/Bcc.

- 3 Enter the e-mail subject.
 - 4 Compose your e-mail. To attach a picture, touch the Menu button  → **Attach**. Select the picture you want to attach from the Photos & Videos application (for more information, see Photos & Videos).
-  **NOTE:** Touch  to remove an attachment.
- 5 Touch **Send** to send the e-mail.

Google Talk

Google Talk is an instant messaging program provided by Google.

To activate Google Talk



- 1 Touch the Application button  →  **Google Talk**.
 - 2 Follow the instructions on the screen to create a Google account if you don't have one, or sign in with your account if you already have one. For more information, see To set up your Google account.
-  **NOTE:** Skip step 2 if you have already signed in to your Google account.
- 3 The Google Talk window opens with your friends list.

To sign in automatically

You can sign in to your Google Talk account automatically whenever you turn on the device.

- 1 In the friends list, touch the Menu button  → **Settings**.
- 2 Select **Automatically sign in**.

To add a new friend to your friends list

-  **NOTE:** You can only add people who have a Google Account.
- 1 In the friends list, touch the Menu button  → **Add friend**.
 - 2 Enter the Google Talk instant messaging ID or Gmail address of the friend you want to add to your friends list.



NOTE: When you type the instant messaging ID of a friend who is already a contact saved in Contacts with the same ID, this matching contact will display on the screen before you finish typing. You can touch the contact whose ID is then entered automatically.

- 3 Touch **Send invitation**.

To view and accept an invitation

- 1 In the friends list, touch the Menu button  → **Invites**. All chat invitations you have sent or received but have not been answered are listed on the pending invitations screen.
- 2 Touch a pending invitation.
- 3 Touch **Accept** or **Cancel**.

When a friend accepts your chat invitation, the pending invitation disappears from the list.

To change your online status and message

- 1 Touch the online status icon  next to your name.
- 2 Select the status you want from the menu.
- 3 To enter your status message, touch the text box on the left of your online status icon and enter your message.
- 4 To change your ID photo, touch the photo icon to open Photos & Videos, then select the photo to use.

To start a conversation

- 1 Touch to select a friend in the friends list.
- 2 Type your message in the text box.
- 3 Touch the **Send** button to send the message.

To add a friend to an active conversation

- 1 On the chat screen, touch the Menu button  → **Add to chat**.
- 2 Select the friend you want to invite to the current conversation.

To disable the chat log

On the chat screen, touch the Menu button  → **Chat off record**. The subsequent chat conversations will not be recorded. To resume the chat log, touch **Chat on record**.

To switch between active conversations

- 1 While on a chat screen or in the friends list, touch the Menu button  → **Switch chats**.
- 2 In the panel that opens, touch the name of the friend you want to chat with.

To close a conversation

- In your friends list, touch and hold the name of a friend with an active chat. Touch **End chat** on the menu that pops up.
- On a chat screen, touch the Menu button  → **End chat**.

To display all friends in your friends list

Only the friends that you chat with most frequently are listed as the most popular ones. If you want to display all your friends, touch the Menu button  → **All friends**.

To show a friend in the most popular list

- 1 In the friends list, touch and hold the friend's name to open the options menu.
- 2 Touch **Show friend**.

To pin a friend

You can pin a friend so that the friend always appears in your most popular friends list.

- 1 In the friends list, touch and hold the friend's name to open the options menu.
- 2 Touch **Pin friend**.



 **NOTE:** To unpin a friend, in the friends list, touch and hold the friend you want to unpin and then touch **Unpin friend** in the options menu.

 **NOTE:** To keep a friend from appearing in the most popular list, touch and hold the friend's name, and then touch **Hide friend** in the menu. If you pinned the friend, the pin will be removed when you hide the friend.

To block a friend from sending you messages

- 1 In the friends list, find the friend to block.
- 2 Touch and hold the friend's name, and then touch **Block friend**.

Your friend is removed from your friends list and is added to the blocked friends list.

 **NOTE:** To unblock a friend, in the friends list, touch the Menu button  → **Blocked**. In the blocked friends list, touch the name of the friend to unblock, then touch OK.

To permanently remove a friend

- 1 In the friends list, find the friend to remove.
- 2 Touch and hold the friend's name, and then touch **Remove friend**.

To find out what device your friend uses to chat on Google talk

- 1 In the friends list, ensure that the Menu button  → **Settings** → **Mobile indicator** is selected.
- 2 In the friends list, check the image that appears to the right of your friend's name. For example, if your friend is using an Android phone, the Android image will appear. If no image is displayed, it indicates that your friend has signed in to Google using a computer.

To sign out from Google Talk

In the friends list, touch the Menu button  → **Sign out**.

Maps



Google Maps helps you find your current location, view real-time traffic situations, and get directions to your destination. You can also use the search tool to locate addresses or places of interest on a map or in a street view.



NOTE: The Google Maps application does not completely cover every location.

To enable location source



To search for desired places or find your current location using Google Maps, you need to enable My location sources:

- 1 Touch Home button  → Menu button  → Settings → Security & location.
- 2 Select Use wireless networks, Enable GPS satellites, or both.



NOTE: Selecting **Enable GPS satellites** allows you to pinpoint locations down to the street-level. However, this mode requires a clear view of the sky and more battery power.

To open Google Maps

Touch the Application button  →  Maps.

To see your location on a map

On the Maps screen, touch the Menu button  → My Location. Your location is marked on the map with a blinking blue dot.



NOTE: Selecting Enable GPS satellites allows you to pinpoint your current location down to the street-level. However, this mode requires a clear view of the sky and more battery power.

To find a location on the map

- 1 On the Maps screen, touch the Menu button  → Search. The search
- 2 To search by typing:
 - a Type the place you want to find into the search box. You can enter an address, a city or country, or a type of business or organization such “restaurant” or “school”.

- b Touch the search key on the keyboard or the search icon  on the search box.

To search by voice:

- a Touch .
- b Say your destination.

 **NOTE:** As you enter information, previous searches or matching locations appear below the search box. You can touch a place name or address to show the location on the map.

- 3 The search results are marked on the map by lettered balloons.

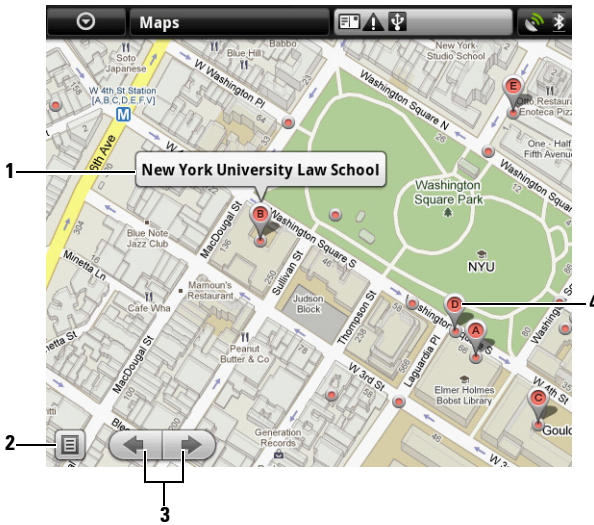

-
- 1 Touch the place name to view the address, details, and reviews for the place if the information is available.
- To obtain directions to the place, touch **Address** → **Get directions** (see To get directions for more information).
 - To switch to street view for the location, touch the **Address** → **Street view** (see To view a map in street view for more information).
-
- 2 Touch to show the list of search results.
-
- 3 If there are multiple search results, touch to view the previous or next result on the map.
-



-
- 4 The search result is marked by a lettered marker. Touch the marker to display the name of the place.
-

To move around a map

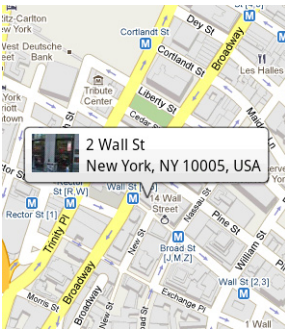
- 1 Flick or drag the map in any direction on the screen to view desired areas.
- 2 If you spot a place of interest while navigating the map, touch and hold the place to display the address (a picture thumbnail is also displayed if the street view for the location is available).



To zoom in or out on a map

Touch  to zoom out and touch  to zoom in.

To change map layers

Google Maps opens with the default map layer. You can apply different types of layers to view additional information or images on the map.



- 1 Touch the Menu button  → Layers.
- 2 From the Layers menu, touch the desired layer to display it on the map.

Map layer

The map layer displays streets, highways, buildings, main establishments, mass transit stations, parks, rivers, lakes, mountains, boundaries, and so on.



Traffic layer

The traffic layer displays colored lines along the roads where real-time traffic data can be collected. Green lines indicate good traffic speeds, yellow ones indicate slower speeds, and brown ones indicate congested traffic.  indicates where construction work is taking place;  indicates where the road is being blocked.

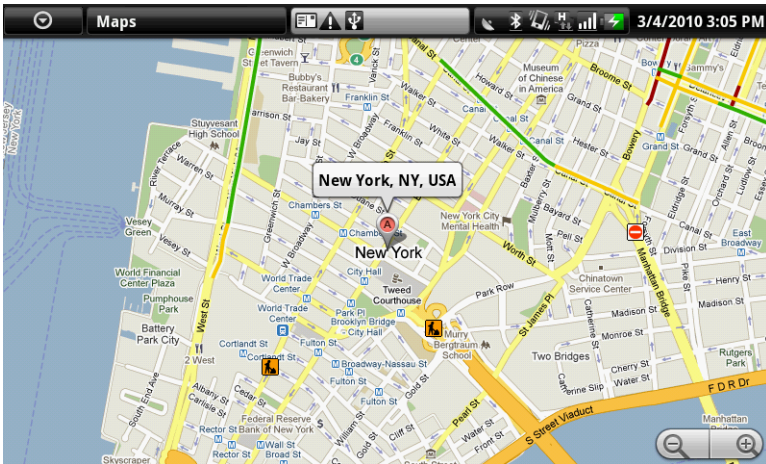

Satellite layer

The satellite layer displays the map in non-real-time satellite view.

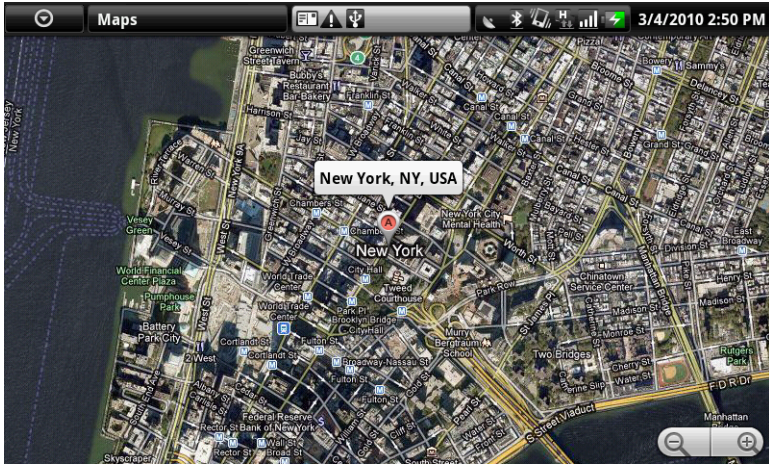



Transit Lines layer

The transit lines layer displays mass-transit routes around the area.





NOTE: Touch the Menu button  → **Layers** → **More layers** to find more layers that you can apply to the map. For information about the other layers, visit [Google Maps on the web](#).

 **NOTE:** To remove all of the layers other than the map layer, touch the Menu button  → **Layers** → **Clear Map**.

To view a map in street view

You can switch to street view for the location that you found on the map. The street view is composed of imagery captured from the streets.

- 1 Locate a place of interest on the map. For more information, see *To find a location on the map* and *To move around a map*.
- 2 On the map, touch the name or address of the place.
- 3 On the location details screen, touch **Street view**.
- 4 To view the area around the place, turn the view on the screen with your finger.
- 5 To move the view along the street, touch the arrows displayed on the screen, or touch the Menu button  → **Step forward** or **Step backward**.

 **NOTE:** While viewing a street view of a location, touch the Menu button  → **Compass mode** to enable the compass mode, which allows you to view the area around the selected location by tilting or turning your device, rather than by moving the view on the screen with your finger.

To get directions

Use Google Maps to obtain directions to your destination.

- 1 When viewing a map:
touch the Menu button  → **Directions**.
Or
When a place is found:
 - a Touch the place's name or address displayed on the map.
 - b On the location details screen, touch **Get directions**.
- 2 Enter the starting point in the first text box and your destination in the second text box.



NOTE: By default, your current location is the starting point, and the place you found on the map is your destination.



1 Starting point

2 Destination

3 Choose how you want to get to your destination: driving, public transportation, or walking.

4 Touch to render directions.

5 Touch to set your current location, a contact address, or a place on the map as the starting point or destination.

3 Touch **Go**. The directions to your destination are listed.

4 Touch **Show on map** or touch a direction instruction on the list to show the directions or routes on the map.

To clear a map

Touch the Menu button  → **Clear Map**. All the search results, directions and traffic indicators are deleted from the map.

Using Google Latitude

 **NOTE:** To use Google Latitude, you will be required to sign in to a Google account.

The Google Latitude location service allows you to share locations with your friends and family who have signed in to the service with their Google accounts. You can also send instant messages and e-mails, make phone calls, and get directions to your friends' locations.

To let your friends view your location and accept their invitations, you need to enable **Join Latitude**.

- 1 While viewing a map in any mode, touch the Menu button  → **Join Latitude**.
- 2 Follow the instructions on the screen to create a Google account if you don't have one, or sign in with your account if you already have one. For more information, see *To set up your Google account*.

 **NOTE:** Skip step 2 if you have already signed in to your Google account.

- 3 Read the privacy policy. If you accept, touch **Agree & share**.

To run Latitude

While viewing a map, touch the Menu button  → **Latitude**.

To invite friends to share locations

- 1 On the Latitude screen, touch the Menu button  → **Add friends**.
- 2 Choose the friends you want to share locations with:
 - **Select from Contacts:** Select friends from your contacts. Friends already using Latitude have an icon next to their names.
 - **Add via email address:** Enter an e-mail address.
- 3 Touch **Add friends** then **OK**.
- 4 Your friends already using Latitude receive an e-mail request and a notification on Latitude that ask them to share locations. If they have not yet joined Latitude, they receive an e-mail that requests them to sign in to Latitude with their Google accounts.

To accept an invitation

When you receive a request to share your location with a friend on Latitude, choose how you want to respond:

- **Accept and share back:** You can see your friend's location, and your friend can see yours.
- **Accept, but hide my location:** You can see your friend's location, but they cannot see yours.
- **Don't accept:** Reject the sharing request. No location information is shared.

To show your friends

You can show your friends on the map or in the list view.

- **Map view**

When you open Google Maps, it displays the locations of your friends. Each friend is marked by a photo icon with an arrow that indicates their location. To see a friend's profile and communicate with them, touch the photo, then touch their location callout right above their photo. To see other friends, touch either one of the arrow buttons next to the callout.

- **List view**

To show a list of your friends, touch the Menu button  → **Latitude**. To see a friend's profile and communicate with them, touch the friend's name from the list.

To connect with your friends

Touch a friend's name in map view or list view to open the friend's profile. In the profile screen, you can communicate with your friend and configure privacy options.

Show on map	See a friend's location on the map.
Shout out to <this friend>	Post a shout-out message that your friends can see on your map callout or in their list of friends.
Chat using Google Talk	Send an instant message using Google Talk. A conversation window opens with that friend.
Send email	Compose and send an e-mail addressed to this friend.
Directions	Get directions to the friend's location.

Hide from this friend	Your friend cannot see your photo icon on the map. To resume location sharing with this friend, touch Unhide from this friend .
Share only city level location	Share only the city or the approximate area you are in, not the street-level location. Your friend can see your photo icon in the middle of the city you are in. To share street-level location, touch Best available location .
Remove	Remove this friend from your list and end all location sharing.

To control what to share and change your public profile

- 1 In Maps, touch the Menu button  → **Latitude**.
- 2 Touch your location callout on the map, or your name on the list of friends.
- 3 Set the following options to your preferences.

Show on map	See your location on the map.
Change your photo	Change the picture that your friends see on the map or in their list of friends. You can take a picture using the Camera application, or select one stored in Photos & Videos.
Edit privacy setting	Manage how your location is shared with your friends: <ul style="list-style-type: none"> • Detect your location: Latitude automatically detects and updates your current location. <p>NOTE: To let Latitude report your location, you must enable My location sources. See To enable location source.</p> <ul style="list-style-type: none"> • Set your location: Select a location from the map, contact addresses or nearby places, or type an address. • Hide your location. All of your friends will not be able to see your location on their maps. • Turn off Latitude: Disable Latitude and end location sharing.

YouTube

YouTube is a web video streaming service that allows you to view videos uploaded by YouTube members.





NOTE: Browsing and viewing videos does not require you to sign in to a YouTube account. However, to use all of the YouTube features, such as rating or commenting on a video or viewing "My account", you must create and sign in to a YouTube account.

To open YouTube



Touch the Application button  →  YouTube.

The YouTube screen opens with the videos grouped into categories such as Most viewed, Most discussed, Top rated, and so on.

To search for a video by typing

- 1 Touch the icon  on the top right of the YouTube screen, or touch the Menu button  → Search to open the search bar.
- 2 Type the video name or keyword into the search box using the on-screen keyboard. The search results that fully or partially match the text being typed appear below the search box. You can:
 - a Scroll the search results and touch a desired one.
 - b Touch the search key on the keyboard or the search icon  on the search box to search for results that match the entered text, then touch a desired search result.
- 3 The videos that match the selected result are listed.
- 4 Touch the video to start playing the video.

To search for a video by voice command

- 1 Touch the icon  on the top right corner of the YouTube screen, or touch the Menu button  → Search to open the search bar.
- 2 Touch .
- 3 Say the video name or a keyword.

- 4 The videos that match the words you said are listed.
- 5 Touch the video to start playing the video.



To search for a video by category

- 1 Touch the Menu button  → **Categories**.
- 2 Scroll the listed categories and touch the category under which the video appears.
- 3 Touch to start playing the video.

To filter videos by different time frames

- 1 Touch the Menu button  → **Settings** → **Filter videos by time** or **Time filter**.
- 2 Select a time frame such as Today or This week.
- 3 The videos that match the selected time frame are listed.

To watch videos

- 1 Select a video listed on the on the YouTube screen. The video starts playing automatically.
- 2 To control video playback, touch anywhere on the screen to display and use the playback controls.
- 3 To end playback, touch the Back button  or the Home button .

To manage a video

- 1 When browsing videos in a list, touch and hold a video to open the options menu.
When playing a video, touch the Menu button .
- 2 You can perform these actions that require signing in to your YouTube account.

Rate	Rate the video with stars.
Comments	Write and send your comments about the video.
Favorite	Add the video's web link to your browser bookmarks.



Share	Send the video's web link to others by e-mail.
Flag	If you find the video inappropriate to get posted and want to have it removed, you can flag the video to notify the service provider.

Android Market

You can use Android Market to download and install applications and games on your device.

 **NOTE:** Applications downloaded from Android Market may not support automatic screen orientation to portrait or landscape.

To open Android Market

- 1 Touch the Application button  →  **Market**.
- 2 Follow the instructions on the screen to create a Google account if you don't have one, or sign in with your account if you already have one. For more information, see [To set up your Google account](#).

 **NOTE:** Skip step 2 if you have already signed in to your Google account.

- 3 Touch the **Accept** button after you read and agree with the **Android Market Terms of Service**.

4 The Android Market screen opens.

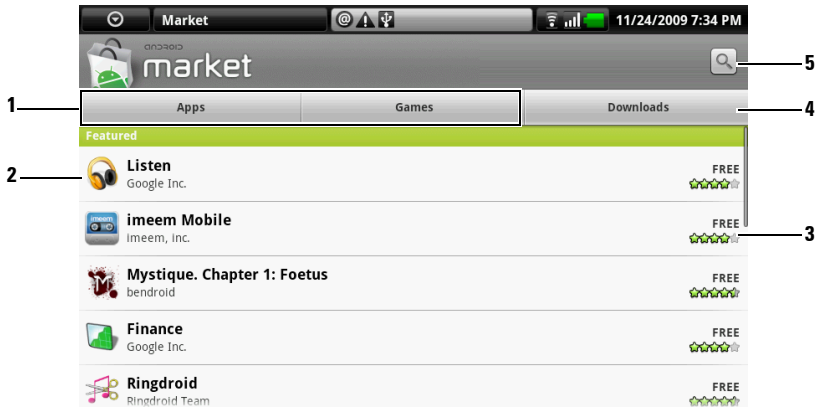

-
- 1
 - Touch the **Apps** tab to view the application categories. All applications available for download are sorted by these categories.
 - Touch the **Games** tab to view the game categories. All games available for download are sorted by these categories.
 - 2 The Market screen opens with featured applications for direct access.
 - 3 Shows user rating about the item and whether it is free or requires a purchase.
 - 4 Touch the **Downloads** tabs to view your downloads.
 - 5 Touch to search Android Market for applications or games.
-

When a category is selected, for example, touch the **Games** tab→ **Brain & Puzzle**:

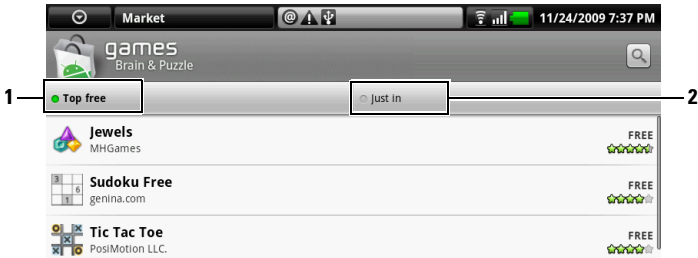

-
- 1 Touch **Top free** to sort the items by rating.
 - 2 Touch **Just in** to sort by date.
-

To download and install an application or game

- 1 Scroll and browse listed applications or games to locate the desired one.
- 2 Touch the application or game you want to download and install.
- 3 On the application details screen, you can read the introduction to the application or game, user ratings and comments, and developer information.



NOTE: Touch the Menu button  and select **Security** to view the functions or data this can access on your device.

- 4 On the application details screen, touch **Install** to start download and installation. The application's downloading screen will show the download progress.



NOTE: If the application requires access to any of your data or functions on your device, Market tells you what the application can access. Touch the OK button to start download and installation.



NOTE: During installation, the icon  appears in the notification area of the status bar. Touch the notification area of the status bar to open the Notifications panel and check download progress.



NOTE: To stop downloading an application, touch **Cancel download** on the application's downloading screen.

- 5 After the application is downloaded and installed on your device, the download icon  appears in the notification area of the status bar.

To open an application or game

From the Market screen:

- 1 Touch the **Downloads** tab on the Market screen.
- 2 Touch the installed application in the list.
- 3 Touch the **Open** button. The selected application starts running.

From the main application menu:

- 1 Touch the Application button .
- 2 Touch the application's icon.

From the status bar:

- 1 Touch the notification area of the status bar where the download icon  appears to indicate a recently downloaded application.
- 2 Touch the name of the application you want to open.



To uninstall an application or game



- 1 On the downloads screen, touch the application you want to uninstall.
- 2 Touch **Uninstall**.
- 3 After uninstallation is completed, you can select the reason for removing the application.



Synchronizing Your Google Data

Through a web connection, your device can synchronize your Google data including Gmail, calendar, and contacts with your computer or any other device that you use to access your Google account.

To select the applications to synchronize

- 1 Touch Home button  → Menu button  → **Settings** → **Data synchronization**.
- 2 Touch to select **Background data** to make all the sync options available.
- 3 Touch to select **Auto-sync** to let the device automatically synchronize the selected data: **Gmail**, **Calendar**, and/or **Contacts**.
- 4 Select the data that you want the device to synchronize automatically: **Gmail**, **Calendar**, and/or **Contacts**.

 **NOTE:** If you wish to synchronize individual applications manually, touch to clear **Auto-sync**, then touch a data option to start synchronization of the touched data. Touch the Menu button  → **Sync now** to sync all of the data manually.

 **NOTE:** While data is syncing, the sync icon  appears on the status bar, and the sync icon  appears on the option of the data being synced.

Amazon MP3

Touch the Application button  →  Amazon MP3.

The Amazon downloader allows you to browse, search, download, purchase and play MP3 music from the Amazon MP3 store.

 **NOTE:** Wireless connection is required to download music; however, searching and listening can be done using a 3G mobile network.

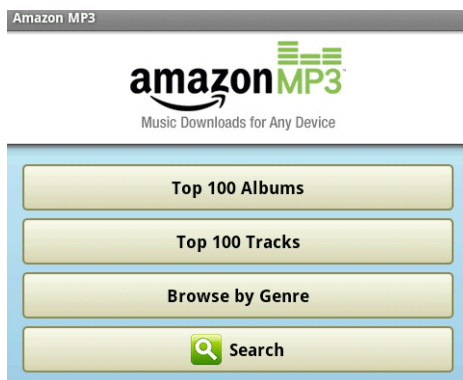

 **NOTE:** Music downloads may require a purchase.

 **NOTE:** To download an album or track, touch the price tag button at the right end of the album or track's entry.







 **NOTE:** To listen to a track's sample clip, touch the track's entry. If you want to stop playback, touch the stop playback button at the left end of the entry.

 **NOTE:** For details on using Amazon MP3, visit Amazon.com/Help.

Customizing Your Dell™ Streak



With the **Settings** menu, you can customize the way your device works to suit your individual needs.

To change display settings

- 1 Touch the Home button  → Menu button  → **Settings** → **Sound & display**, or
touch the Application button  → **Settings icon**  → **Sound & display**.
- 2 Scroll down the menu to use the options grouped under the **Display settings** bar, and then touch the desired option.
- 3 Flick the list to locate and touch a desired item.
- 4 To enable a setting, touch the setting option to select the check box  ;
to disable a setting, touch the setting option to clear the check box .

Orientation	By default, the screen will switch the orientation to landscape or portrait as you rotate the device.
Animation	Set the device to play an animation for opening and closing windows.
Light Adaptive Brightness Control (LABC) Mode	Set the device to adjust the screen brightness automatically based on the surrounding light conditions.
Brightness	Manually adjust screen brightness. <ol style="list-style-type: none">1 Drag the brightness slider horizontally or touch the desired portion of it to increase or decrease the yellow bar. The longer the yellow bar is to the right, the brighter the screen.2 Touch OK to confirm adjustment.







Screen timeout

- Set how long the screen remains on after the last operation. Scroll the options and touch a preferred timeout period; to disable this feature select **Never timeout**.
- The screen automatically turns off and locks itself after an inactivity timeout selected here has passed.
- To turn on and unlock the screen, press  and then touch the Menu button .

NOTE: If you select **Never timeout**, the screen remains on indefinitely and quickly consumes battery power.





NOTE: If **Settings** → **Security & location** → **Screen unlock pattern** is enabled, you need to draw the unlock pattern to unlock the screen. See *Protect Your Device Data With a Screen Unlock Pattern* for details.

To change sound and ringtone settings



- 1 Touch the Home button  → Menu button  → **Settings** → **Sound & display**, or
touch the Application button  → **Settings** icon  → **Sound & display**.
- 2 Use the options grouped under the **Sound settings** bar, and then touch a desired option.
- 3 Flick the list to locate and touch a desired item.
- 4 To enable a setting, touch the setting option to select the check box  ;
to disable a setting, touch the setting option to clear the check box .

Silent mode	Mute everything except alarms, music and videos. NOTE: If Silent mode is enabled, only Media volume and Phone vibrate are adjustable.
Ringer volume	Adjust ringer volume for incoming calls and notifications. 1 To adjust ringer volume for incoming calls, drag the Incoming call volume slider horizontally or touch the desired portion of it to increase or decrease volume. 2 If you want to set a different volume for notifications, touch Use incoming call volume for notifications to clear its check box. Then adjust the volume in the same way. 3 Touch OK to confirm adjustment.
Media volume	Adjust volume for music and video playback. 1 Drag the Media volume slider horizontally or touch the desired portion of it to increase or decrease volume. 2 Touch OK to confirm adjustment.
Phone ringtone	Select a desired ringtone for incoming calls.
Phone vibrate	Set the device to vibrate for incoming calls.
Notification ringtone	Select a desired ringtone for notifications.
Audible touch tones	You can hear a tone as you dial using the on-screen dial pad.
Audible selection	You can hear a tone as you touch the screen to select items.
SD card & USB notifications	You can hear a tone when you unmount the SD card and insert the USB cable.

To manually set the date, time and time zone

- 1 Touch the Home button  → Menu button  → Settings → Date & time, or
touch the Application button  → Settings icon  → Date & time.
- 2 Touch a desired option.



3 Flick the list to locate and touch a desired item.

4 To enable a setting, touch the setting option to select the check box  ;
to disable a setting, touch the setting option to clear the check box .

Select time source

- **Manual:** To manually adjust the date, time and time zone, select this item.
- **Mobile Cell Network:** Your device automatically displays the network-provided date, time zone and time.
- **Internet:** Your device automatically displays the Internet based date and time.



Set date

- 1 Touch or touch and hold  or  to adjust the month, day and year; you can also touch the month, day or year to type a date using the on-screen keyboard.
- 2 Touch **Set** to confirm the date.

Set time zone

Select a city or region that represents the time zone for your device. Touch the Menu button  to sort the time zone list alphabetically or by time zone.

Set time

- 1 Touch or touch and hold  or  to adjust the hour and minute; you can also touch the hour or minute to type a time using the on-screen keyboard.
- 2 Touch the AM/PM button if the 12-hour format is in use.
- 3 Touch **set** to confirm the time.

Use 24-hour format





Clear the check box of this feature if you want to display time using the 12-hour format.

Select date format

Select a format used for displaying the date on the status bar.

To choose a language

Set the language of the display text.

- 1 Touch the Home button  → Menu button  → Settings → Locale & text → Select locale, or touch the Application button  → Settings icon  → Locale & text → Select locale.
- 2 Select a language of your choice from the list that appears.

Protecting Your Dell™ Streak





Protect Your Device Data With a Screen Unlock Pattern

You can protect your device data against unauthorized access by locking the touch screen with a screen unlock pattern. Once the unlock pattern is enabled and the screen is locked, you need to draw the correct unlock pattern to unlock the screen.

After you fail to draw the correct unlock pattern on the screen for five consecutive times, you will be asked to wait for 30 seconds before you can try again. If you no longer remember your screen unlock pattern, follow these steps to unlock your screen:

- 1 Touch **Forgot pattern**.
- 2 When prompted, sign on to the Google website using your Google account name and password.
- 3 Draw a new screen unlock pattern as described in To create a screen unlock pattern.
- 4 If you fail to obtain a new unlock pattern following the above steps, visit Dell.com/support.

To create a screen unlock pattern

- 1 Touch the Home button  → Menu button  → Settings → Security & location → Set unlock pattern, or
touch the Application button  → Settings icon  → Security & location → Set unlock pattern.
- 2 Read the instructions on the screen and then touch Next.

- 3 You can touch the Menu button  to study the animated example of how to draw a pattern. Then touch **OK**.

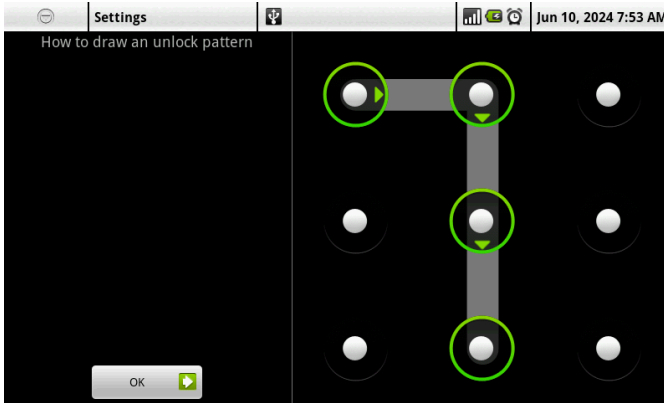

- 4 Drag your finger to draw the unlock pattern by connecting at least four dots in a vertical, horizontal and/or diagonal direction. Take your finger off the screen when a pattern is drawn.

 **NOTE:** You must flick your finger on the screen to create the pattern and not touch individual dots.

- 5 The device records the pattern if it is correctly drawn. Touch **Continue**.



- 6 Draw the pattern again as prompted, and then touch **Confirm**.

 **NOTE:** To change your unlock screen pattern, you need to draw the old pattern before proceeding with steps 4 to 6 to draw a new one.

To enable or disable the screen unlock pattern and change related settings

- 1 Touch the Home button  → Menu button  → Settings → Security & location → **Require pattern**, or

touch the Application button  → Settings icon  → Security & location

- 2 To enable a setting, touch the setting option to select the check box  ; to disable a setting, touch the setting option to clear the check box  .

Require pattern	Select or clear the Require pattern check box to enable or disable the screen unlock pattern.
Use visible pattern	Clear the Use visible pattern check box if you do not want the lines of the unlock pattern to display on the screen when you draw it.
Use tactile feedback	Clear this option if you do not want the device to give you tactile feedback when drawing the unlock pattern.





Protect Your SIM Card With the SIM Lock Password

You can protect your SIM card against unauthorized use with a personal identification number (PIN). After a PIN is enabled to lock your SIM, you will need to enter the PIN each time you turn on the device in order to unlock your SIM.





 **NOTE:** The SIM card will be permanently locked if you enter the incorrect PIN for three consecutive times. You must then enter the Personal Unblocking Key (PUK) to unlock the SIM card. Please contact your service provider to obtain the PUK.

 **NOTE:** You can make emergency calls without unlocking the SIM.

To enable the SIM card PIN

- 1 Touch the Home button  → Menu button  → Settings → Security & location → Set up SIM card lock → Lock SIM Card, or touch the Application button  → Settings icon  → Security & location → Set up SIM card lock → Lock SIM Card.
- 2 Type your SIM card PIN using the on-screen keyboard, and then touch OK.

To change the SIM card PIN

- 1 Touch the Home button  → Menu button  → Settings → Security & location → Set up SIM card lock → Change SIM PIN, or
touch the Application button  → Settings icon  → Security & location → Set up SIM card lock → Change SIM PIN.
- 2 Type the old SIM card PIN using the on-screen keyboard, and then touch OK.
- 3 Type the new SIM card PIN, and then touch OK.
- 4 Type the new SIM card PIN again, and then touch OK.

Applications

Camera



Your device has a 5.0 megapixel camera with auto-focus feature that allows you to capture and share high-quality pictures and videos.



NOTE: Before you use the camera application, you need to install a microSD card in your device. All pictures and videos that you capture using your device camera are stored on the microSD card. For more information on how to install a microSD card on your device, see [Install the microSD card](#).

To start the camera

To start the camera, do one of the following:



- Press and hold the camera button .
- Touch the Application button  → **Camera** .



The screen automatically shifts to landscape orientation after you start the camera.

To change the capture mode

- 1 Touch the viewfinder screen to display the on-screen camera controls.
- 2 On the upper left corner of the camera screen, touch **Photo** if you want to capture photos; touch **Video** if you want to shoot videos.

To capture pictures

- 1 Touch the viewfinder screen to display the on-screen camera controls.
- 2 Touch **Photo** to switch to the photo mode.
- 3 Focus on the object in the viewfinder screen. If necessary, touch + or - to zoom in or zoom out the viewfinder.
- 4 To start the auto focus mode, half-press and hold the camera button .
- 5 Press the camera button  all the way down and release to capture the picture.

 **NOTE:** To achieve optimal focus such as for taking a close shot, half-press and hold the camera button  to use the auto-focus mode. Then without releasing  press it again to take a picture.

 **NOTE:** To capture a picture such as a self-portrait using the front-facing camera lens, touch the Menu button  → **Use Front-Facing Camera.**

To manage pictures

- 1 Touch the viewfinder screen to display the on-screen camera controls. The pictures you have captured most recently appear as thumbnails on the **Recent Pics** bar along the left of the screen.
- 2 Touch a picture thumbnail to display the full picture on the picture viewing screen. Touch **More...** to open **Photos & Videos** and see more thumbnails of the captured pictures.
- 3 On the right side of the picture viewing screen, you can touch the following task buttons to manage the displayed picture:

Share



- **Bluetooth Printer:** Print out the picture with a Bluetooth printer that is paired with your device.
 - **Email:** Send the picture to someone using your e-mail address. For more information, see E-mail.
 - **Facebook:** Upload the picture to this social networking website where your online friends can view your posted pictures. To upload photos to Facebook, you must first sign in to your Facebook account.
 - **Flickr:** Upload the picture to this photo album website where you can share pictures with your online friends. To upload photos to Flickr, you must first sign in to your Flickr account (Yahoo! account).
 - **Gmail:** Send the picture to someone using your Gmail address. See Gmail for details.
 - **Picasa:** Upload the picture to this photo album website where you can share pictures with your online friends. To upload photos to Picasa, you must first sign in to your Picasa account (Google account).
 - **Text Messages:** Send the picture with a multimedia message. For more information about multimedia messaging, see To compose and send a multimedia message.
-

Edit	<p>Scroll the tools listed along the left hand side of the screen and select one to edit your picture:</p> <ul style="list-style-type: none"> • Rotate & Flip: Touch a rotate style on the left to decide how you want to rotate the picture. • Crop: Cut the desired portion of the picture using these techniques: <ul style="list-style-type: none"> – Touch the Select Ratio button, then touch Freedom, Original or Custom to set the dimension ratio of the crop frame. – Drag the crop frame to where you want it to be. – To increase or reduce the crop frame size, touch any of the frame’s angles. • Adjust Colors: Touch a coloring tool to adjust the picture’s color presentation. • Effects: Select an effect style and see how the effect is applied to the picture. • Frames: Create a frame to add to the picture. • Text: Add a text callout to the picture. You can adjust the size, color and style of the text callout. • Clipart: Add an image to the picture. You can rotate and adjust the size of the image. • Draw: Draw an image to add to the picture using the supplied drawing styles. • Resize: Resize the dimension of the picture.
Set as	Set the picture as a contact’s visual caller ID or display it as a Home screen wallpaper.
Delete	Delete the displayed picture.

To adjust camera settings

- 1 Touch the viewfinder screen to display the on-screen camera controls.
- 2 Flick the settings bar along the right side of the camera viewfinder and touch the desired setting.
- 3 Touch the desired value for the setting, for example, to change the **Scene** mode from **Automatic** to **Night**.



To capture videos

- 1 Touch the viewfinder screen to display the on-screen video controls.
- 2 Touch **Video** to switch to the video recording mode.
- 3 Frame your subject on the viewfinder.
- 4 Press  to start recording.
- 5 Press  again to stop recording.

To adjust video settings

- 1 Touch the viewfinder screen to display the on-screen video controls.
- 2 Flick the settings bar along the right side of the video viewfinder and touch a desired setting.
- 3 Touch the desired value for the setting, for example, to change the **Scene** mode from **Automatic** to **Night**.

To play videos

- 1 Touch the viewfinder screen to display the on-screen video controls.
- 2 The videos you have just recorded appear as thumbnails on the **Recent Videos** bar along the left side of the screen. Touch **More...** to see more thumbnails of the videos on Photos & Videos.
- 3 Touch a thumbnail to display the video image on the video viewing screen. Touch the video image to start video playback.
- 4 To control playback, use these controls below the viewing screen:
 - Touch the  button to pause and the  button to resume playback.
 - Touch or drag the yellow playback progress bar to rewind or fast-forward the video.

To manage videos

On the right hand side of the picture viewing screen, you can perform these tasks for the displayed video:

Share	<ul style="list-style-type: none">• Gmail: Send the video using Gmail.• Text Messages: Send the video as a multimedia message. See Receiving text and multimedia messages.• YouTube: Upload the video to the video streaming website YouTube, where people can view the posted video. To upload videos to YouTube, you must first sign in to your YouTube account.
Delete	Delete the video.

MicroSD

The files on your device are stored on the microSD card. To exchange pictures, videos, music, and other files between your device and a computer, use the microSD card as a USB drive by connecting the device to a computer with the included USB cable.

To set the microSD card as a USB drive

- 1 Connect the device to the computer by plugging the 30-pin connector into the device and the USB connector into the USB port on the computer.
- 2 The USB connection dialog pops up; the USB notification icon  appears on the status bar's notification area.
- 3 Depending on your own needs, touch to select one of these actions:
 - **Copy media files to/from your computer (MTP):** Select this option if you wish to load media files through applications that require the Media Transfer Protocol (MTP).
 - **Copy other files to/from your computer:** Select this option if you wish to have full access to all the files stored on your microSD card.
 - **Charge only:** Select this option if you simply wish to charge your device using your computer.
- 4 You can touch one of these buttons based on your requirement:

- **Use each time:** After you select this option, the USB connection dialog does not appear the next time you plug in the USB cable. The device automatically performs the same action that you selected last time.
- **Always ask:** Every time you plug in the cable, the USB connection dialogue appears and asks you to select an action.



NOTE: After you select **Copy other files to/from your computer**, open the **My Computer** window on your computer to locate a removable drive which is the microSD card installed in your device. Then copy desired files such as music or pictures from another drive/folder to the removable drive, or vice versa.

To turn off USB storage

The device will not recognize the microSD card when the card is being used as a USB drive. You will not be able to use the device's applications that involve saving or retrieving files on the microSD card, such as camera or music playback. You need to turn off USB storage for the device to recognize the microSD card when the device is connected to a computer.

To turn off the USB storage function:

- 1 Touch the notification area on the status bar to open the notification menu.
- 2 Touch **Turn off USB storage** → **Turn Off**.

To remove the microSD card:

- 1 Press and hold the Power button  and then touch the **Power off** option to turn the device off.
- 2 Remove the back cover.
- 3 Slide and lift the microSD card out of the slot on the device.

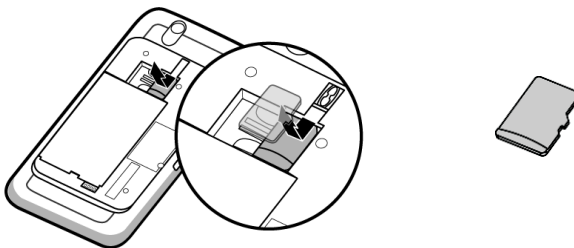



Bluetooth®

Bluetooth is a short-range wireless communications technology that lets your device connect over a wireless network to other Bluetooth-enabled devices for data exchange.



Bluetooth on your device operates in three different modes:

On	Bluetooth is turned on. Your device is enabled to detect Bluetooth devices within range, but will not be found by them.
Discoverable	Bluetooth is turned on, and other Bluetooth devices can detect your device.
Off	Bluetooth is turned off. Your device is unable to send and receive data using Bluetooth.

To turn on Bluetooth and make the device discoverable

- 1 Touch the Home button  → Menu button  → Settings → Wireless controls.
- 2 Select the **Bluetooth** check box to turn on Bluetooth. The Bluetooth icon  appears in the status bar.
- 3 Touch **Bluetooth settings**, then select the **Discoverable** check box to make the device recognizable by other nearby Bluetooth devices.

To pair and connect a Bluetooth headset

- 1 Touch the Home button  → Menu button  → Settings → Wireless controls → **Bluetooth settings**.
- 2 Touch and select the **Bluetooth** check box. Your device starts to scan for Bluetooth devices within range and then displays all detected devices below the **Bluetooth devices** banner.



NOTE: To detect more devices, touch **Scan for devices**.



- 3 Touch the name of the device you wish to initiate a connection with.
- 4 You may be prompted to enter a password to authenticate. Enter the same password on both devices, or enter the specific one provided by the device manufacturer. Ensure that you read the documentation of the pairing device to check if it requires a default password.

- 5 When the pairing is successful, **Paired but not connected** is displayed under the paired device.
- 6 Touch the paired device to start connection. When the paired device is successfully connected to your device, the Bluetooth connected icon  appears in the status bar.



 **NOTE:** To make and receive calls or listen to the music using a Bluetooth headset, pair it first with your device.

 **NOTE:** Pairing is a one-time process. Once your device successfully pairs with another device, your device recognizes that device without re-entering your password.



To end a Bluetooth connection

- 1 Touch the Home button  → the Menu button  → **Settings** → **Wireless controls** → **Bluetooth settings**.
- 2 Touch and hold the name of a connected device.
- 3 Touch **Disconnect** on the pop-up menu that appears.

To terminate a pairing partnership



- 1 Touch the Home button  → Menu button  → **Settings** → **Wireless controls** → **Bluetooth settings**.
- 2 Touch and hold the name of a paired device.
- 3 Touch **Unpair** on the pop-up menu that appears to erase all pairing information with that device. You need to enter the password again if you want to restore a Bluetooth connection to that device.

To change your device's Bluetooth name

- 1 Ensure that you have turned on Bluetooth on your device ( indicates in the status bar that Bluetooth is enabled).
- 2 Touch the Home button  → Menu button  → **Settings** → **Wireless controls** → **Bluetooth settings** → **Device name**.
- 3 Enter a name to identify the device when you connect using Bluetooth.
- 4 Touch **OK**.

Photos & Videos

To view and manage the pictures and videos stored on your device, touch the

Application button  → **Photos & Videos** .

 **NOTE:** Before you run the Photos & Videos application, ensure that a microSD card containing media files is installed on your device. All pictures and videos that you capture using your device camera are stored on the microSD card. For more information on how to install a microSD card on your device, see [Install the microSD card](#).

To view pictures

- 1 Touch the **Photos & Videos** tab to choose to display the thumbnails of all pictures and videos, the files you have stored separately as Favorites, only the pictures or videos, or only the pictures or videos captured with the device camera.
- 2 On the Photos & Videos screen, flick the picture thumbnails horizontally until the desired one is located.
- 3 Touch the picture thumbnail to display the full picture.
- 4 When a picture is displayed in full screen:
 - Flick the picture to view the next or previous picture.
 - Zoom the picture in or out: Pinch the picture with two fingers, then move the fingers apart to enlarge the picture, or bring them closer together to reduce the picture.
 - When a picture view is being enlarged, drag the enlarged picture across the screen until the required portion appears.



To manage a picture

When a picture is displayed in full screen, touch the Menu button  or touch and hold a picture to open the options menu for the following actions.



Share	To print the picture using the Bluetooth printer, or send the picture or video using the available applications described on Share.
Edit	To edit the picture using the available tools described on Edit.

Slideshow	Playback all of the pictures as a slideshow. To stop a slideshow, touch the screen or touch the Back button  .
Add to Favorites	Copy the picture or video as your favorites that you can access by touching the Favorites tab.
Delete	Delete the picture or video.
Rename	Change the name of the picture or video.
Set as	Set the picture as the Home screen wallpaper, or as the visual ID for a contact: <ol style="list-style-type: none"> 1 Drag the crop frame to where you want it to be. 2 To increase or reduce the crop frame size, touch any of the frame's angles. 3 Touch the check button to cut the picture.
Setting	Set up slideshow playback duration, transition style, and background music.
Details	View the information of the picture or video.

To play videos

- 1** Touch a video thumbnail to start playback of the video.
- 2** To control playback, use these controls below the viewing screen:
 - Touch the  button to pause and the  button to resume playback.
 - Touch or drag the yellow playback progress bar to rewind or fast-forward the video.



To mark pictures and videos

- 1** In the thumbnail view of the pictures and videos, touch the Menu button  → **Mark**.
- 2** Touch the thumbnails to mark the pictures or videos that you want.
- 3** Touch the Menu button  and choose to delete the marked pictures or videos, or add them as your favorites.

Music

 **NOTE:** The Music application only plays audio files saved on the microSD card of your device. Before opening Music, ensure that the needed audio files have been copied to the microSD card of your device.

To open Music

Touch the Application button  → Music .

The Music screen opens to display the **Recently Added**, **Your Most Played**, and **Random Sampler** albums as a slideshow. You can swipe the screen to display your desired album category.



All the music files available on your device are grouped into these categories: **Albums**, **Artists**, **Genres**, **Playlists**, and **Songs**.

To select a song

- 1** Touch an album or category to view the list within it.
- 2** Inside a category, flick the list until you find the music you want to play. For instance, to select music by artist:
 - a** Touch **Artists**. A list of artists opens in alphabetical order.
 - b** Flick the list and touch the name of an artist. A list displays the songs by the artist according to the album name.
 - c** Touch a music file to open the music playback screen and play the music.

To control music playback





- 1 The album's cover image if it has one.
- 2 The name of the song being played.
- 3 The name of the artist.
- 4
 - If the song is playing for more than five seconds, touch to jump to the beginning of the song.
 - If the song is playing for less than five seconds, touch to play the previous song.
- 5 The passing playback time.
- 6
 - Touch the playback control bar to jump to any part of the song.
 - Drag and scroll the playback control bar forward to fast-forward the song.
 - Drag and scroll the playback control bar backward to rewind the song.
- 7 Touch () to pause playback; touch () to resume playback.
- 8 Touch to play the next song.
- 9 The duration of the song.

10 Touch to cycle through the repeat modes.

11 Touch to turn the shuffle mode on and off.



 **NOTE:** Press the volume up button  or volume down button  to adjust the playback volume.

 **NOTE:** If you are listening to the music with the supplied 3.5 mm headphones, press the button on the wire of the headphones to pause and resume playback. Press and hold the button to jump to the next song.

 **NOTE:** On the Music screen, touch **Shuffle All Songs** to play all songs in your library in random order. The first randomly selected song starts to play.

To create a playlist

- 1 On the **Music** screen, touch an album or category to open the list inside the album or category.
- 2 Flick the screen until you reach the album, artist, or song that you want to add to the playlist.
- 3 Touch and hold the album, artist, or song that you want to add in the playlist. A pop-up menu opens.
- 4 Touch **Add album/artist/song to playlist...**

 **NOTE:** To add an album or artist to the playlist, you can also touch the album or artist, and then touch the Menu button  → **Add album/artist to playlist...**

- 5 In the **Add to playlist** window, touch **New playlist**.



 **NOTE:** If you want to add the artist, album, or song to an existing playlist, touch the playlist's name in the **Add to playlist** options menu.

- 6 Enter the name for your new playlist in the text field and then touch **Create Playlist**.

Calendar

Use the calendar to schedule and manage your events, meetings, and appointments.

To open the calendar

Touch the Application button  → **Calendar** .

To set up an event

- 1 On any calendar view, touch the Menu button  → **New event** to open the **Event details** screen.
- 2 Type the event name using the on-screen keyboard.
- 3 If there is a time period for the event, touch and type the **From** and **To** date and time.
If the event is a special occasion such as a birthday or takes a whole day, set the **From** and **To** date, and then select the **All Day** check box.
- 4 Type the event location and description.
- 5 Set the event reminder time in **Reminders**, then decide whether it is a recurring event in **Repetition**.
- 6 Touch **Done** and the event is created.

 **NOTE:** To quickly set up an event in day, week, or month view, touch and hold an empty time slot → **New event**. A new **Event details** screen opens with the selected time slot and date in the **From** and **To** fields.

To view the calendar

You can display the calendar in daily, weekly, monthly, or agenda view. To change the calendar view, touch the Menu button  → **Day/Week/Month/Agenda**.

While viewing the calendar you can:

- In day or week views, touch an event to open a quick view window of the event on the lower part of the screen.
- Touch the quick view window to view details about the event.

- Touch and hold an event to open a menu with options for viewing, editing, or deleting the event, or creating a new event.

Event reminders

If you set a reminder for an event, the upcoming event icon  appears in the notifications area of the status bar when the reminder time arrives.

To view, dismiss, or snooze a reminder

- 1 Touch the notification area of the status bar, to open the notification menu.
- 2 Touch the upcoming event name to display the event.

 **NOTE:** If you have other pending event reminders, these events will also appear on the screen.



- 3 Touch **Snooze all** to put off all event reminders for five minutes. Touch **Dismiss all** to turn off all event reminders. Press  to keep the reminders pending in the notification area of the status bar.

Alarm Clock

Your device can work as an alarm clock. You can set as many alarms as you require.



To open the alarm clock

Touch the Application button  → Alarm Clock .

 **NOTE:** To hide the current time clock from the screen, touch the Menu button  → **Hide clock**; to display the current time clock, touch the Menu button  → **Show clock**.

To set an alarm

- 1 Touch one of the available alarms.
- 2 The Set alarm menu opens with these settings:

Turn on alarm	Turn on the alarm that you have set on the device.
Time	Set the alarm time. Adjust the time by touching  or  , or touch the hour and minute fields to enter a time. Touch AM to change to PM or vice versa, then touch Set when done.
Ringtone	Select the alarm ringtone.
Vibrate	Select the check box if you want the device to vibrate when the alarm goes off.
Repeat	Select the days you want the alarm to ring, then touch OK . NOTE: If you did not select any days for the alarm, Never appears to hint that your alarm will only go off once.
Label	Give the alarm a name for a special event.



NOTE: On the **Alarm Clock** screen you can also add a new alarm by touching the Menu button  → **Add alarm**.

To temporarily disable an alarm

On the **Alarm Clock** screen, clear the check box of alarm time you want to disable.

To delete an alarm



- 1 On the **Alarm Clock** screen, touch the alarm time you want to delete.
- 2 On the Set alarm screen, touch the Menu button  → **Delete alarm**.

To silence all alarms

You can change the settings to choose if the alarm should ring when the device is in Silent mode.

- 1 On the **Alarm Clock** screen, touch the Menu button  → **Settings**.
- 2 Touch **Alarm in silent mode** to set if the alarm should ring when the device is in Silent mode.









Calculator

- 1 Touch the Application button  → **Calculator** . The basic calculator panel opens.
- 2 Perform calculations by touching the corresponding buttons on the calculator panel; touch the CLEAR button to clear the displayed numbers or symbols.
- 3 To perform advanced calculations, flick the basic calculator panel away to the left and reveal the advanced panel, or touch the Menu button  → **Advanced panel**.

Recorder

Open this application to record voice and sounds and then play them back. You can also set the recording as a ringtone for your device.

 **NOTE:** Recorder only supports recording in the amr format.

- 1 Touch the Application button  → **Recorder** .
- 2 Touch  to start recording.
- 3 Touch  to end recording.
- 4 Touch  to start playback of the recording; touch  to stop playback.
- 5 Touch **Save this recording** to save the recording on the microSD card.
- 6 To play back a sound recording again, touch the Application button  → **Music**  → **Songs**, then select a recording to play. For information about **Music**, see Music.

Voice Control

Touch the Application button  → **Voice Control** .



Voice Control is a voice commander tool for you to say voice commands to call contacts, find contacts, and dial numbers.



NOTE: To learn how to say the voice commands to start call actions, touch the Menu button  → **Tutorial** and follow the instructions on the screen.

To adapt the device to your voice

To make your device easily recognize your voice commands to start desired actions, you need to get it used to your voice.

- 1 Touch the Menu button  → **Settings** → **Adaptation** → **Adapt Voice**.
- 2 Touch the Menu button  → **Start**.
- 3 Follow the instructions to say the command examples, preferably in a quiet place with minimum noise around.

To say a voice command to start an action



- 1 When Voice Control prompts you with available voice commands, say the command that includes the number or the name of the contact you want to call. These items are displayed as variable strings within the brackets. For example, if you want to call a contact named John, use this command **Call <Name or #>** and say "Call John" to your device.
- 2 Once your device recognizes your command, it automatically calls the contact or number. If you have enabled **Settings** → **Confirmation** → **Always confirm**, the device waits for your confirmation before it takes the action.

Outlook Tasks

Touch the Application button  → Outlook Tasks .

Use this application to keep track of your to-do items.

To add a task

- 1 Touch the Application button  → Outlook Tasks  to open the Task list.
- 2 Touch the New task entry.
- 3 Enter the following information about the task:

What	Enter the subject of the task.
When	Set when the task starts and when it should be completed.
Description	Summarize what the task is about.
Reminder	Select this option and enter a reminder time if you need your device to remind you about the task at a particular time.
Extra options	<ul style="list-style-type: none">• Status: Touch the Status area to mark the task's status using the available labels.• Priority: Touch the Priority area to set the task's priority using the available labels.• Privacy: Touch the Privacy area to decide whether it is a private or public task.

- 4 Touch Save and the task is listed on the Tasks list.

To adjust task settings

On the Tasks list, touch the Menu button  → **Settings**.

Hide completed tasks	After you select this option, tasks marked as Completed become invisible.
Set alerts & notifications	Choose one of these reminder modes: <ul style="list-style-type: none">• Alert: The screen displays task information directly when the reminder time arrives.• Status bar notification: The Task Alert icon appears in the notification area of the status bar when the reminder time arrives.• Off: Disable the reminder.
Select ringtone	Choose a ringtone for the reminder.
Vibrate	Choose if the device vibrates to alert you about the task.

To manage a task reminder

- 1 Touch the notification area of the status bar when the icon appears.
- 2 Touch a **Task alert** entry to view the task info.
- 3 Touch **Snooze all** if you want the reminder to alert you a few minutes later; touch **Dismiss all** if you want to permanently disable the reminder.

SIM Manager



Touch the Application button  → **SIM manager** .

You can add and delete contacts on your SIM card, and check the number of the contacts and messages stored on it.

To copy selected entries from your device's contacts to your SIM card, touch the Menu button  → **Import Contacts**.



Outlook Notes

To enter a note

- 1 Touch the Application button  → Outlook Notes  to open the Notes screen.
- 2 Touch the **New note** entry to open the **Create note** screen.
- 3 Type your note into the note field using the on-screen keyboard.
- 4 Touch the **Save** button to save the note that you have completed and return to the Notes screen, where the new note entry is displayed.

 **NOTE:** Touch the **Cancel** button if you do not want to save the note.

To delete a note

- 1 Touch the Application button  → Outlook Notes  to open the Notes screen.
- 2 Touch the entry of the note you wish to delete. The **Edit note** screen opens.
- 3 Touch the **Delete** button to permanently delete the note from your device.

Quickoffice

Touch the Application button  → Quickoffice .

With Quickoffice you can view Microsoft® Word (.doc), Microsoft Excel (.xls), Microsoft PowerPoint® (.ppt), and Adobe Acrobat® PDF files stored on your device's microSD card or attached to e-mail.

To open and view a document saved on the microSD card

- 1 Touch **Memory card**.
- 2 Navigate folders stored on the card to locate your desired file.
- 3 Touch the file to open it.



 **NOTE:** If you want to open a recently viewed document, touch **Recent documents**.

To view a document or spreadsheet

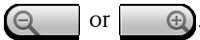
- 1 Swipe the document to view the desired section.
- 2 To zoom in or out the desired area of a document, touch anywhere on the document to activate the zoom mode, and then touch the zoom controls



To find text in a document

- 1 Touch the Menu button  → Search. The search box opens.
- 2 Type the text you want to find into the search box.
- 3 The matching texts are highlighted.
- 4 On the right end of the search box, touch the search icons  or  to locate the matching texts along the document.

To sort folders or files using Quickoffice

Touch the Menu button  → Sort by to rearrange folder and file listings by name, type, size or modification date.

To rename, delete, copy, move folders or files, or view folder or file properties.

Touch and hold a file or folder, and from the pop-up menu select the task you want to do.



NOTE: Quickoffice supports the following file formats:

- Microsoft Word: 97-2003 .doc, 2007 .docx
- Microsoft Excel: 97-2003 .xls, 2007 .xlsx
- Microsoft PowerPoint: 2000-2003 .ppt, 2007 .pptx
- Adobe Acrobat PDF: 1.0-1.4/Acrobat 5, 1.5-1.7/Acrobat 8, 1.7 Acrobat 9
- Text Files: .txt



NOTE: Quickoffice for Android supports viewing for 2007 and earlier versions of Microsoft Word, Excel, and PowerPoint documents.

Synchronizing Your Dell™ Streak and Computer Using Dell PC Suite

Connect to a Computer and Install Dell PC Suite

- 1 Connect the 30-pin-to-USB cable to your device and computer and wait for your computer to automatically install software driver.
- 2 Once the installation is complete, a new “Removable Disk” will become available on your computer. This will allow you to view the contents of the microSD card from your computer.
- 3 Browse the contents of the Removable Disk from your computer, double-click on the folder **Dell PC Suite**, and then double-click on **DellPCSuite.exe** in order to install the synchronization software.



NOTE: You can also download Dell PC Suite by visiting support.dell.com and selecting your product model.

- 4 After the installation is complete, the **Phone Connection Wizard** window appears. Follow the instructions and enter the name of your device to let Dell PC Suite identify the device.
- 5 Once Dell PC Suite detects the connected device, the Dell PC Suite window opens automatically. The icon  appears at the bottom right of the compute screen.



NOTE: If Dell PC Suite does not start automatically, on your computer desktop click **Start**→ **Programs**→ **Dell**→ **PC Suite**.

Using Dell PC Suite



NOTE: For detailed information on all of the PC Suite functions and settings, click **Help** on the menu bar at the top, or click the **Help** button next to the desired item.

To synchronize using Sync Manager

- 1 On the Dell PC Suite window, click the **Sync Manager** icon. The Sync Manager window opens.
- 2 On the Sync Manager window, click the **Settings...** button or click **Tools**→**Settings...** to open **Synchronization Settings Wizard**.
- 3 Follow the instructions on the screen to select the Outlook® application and categories (**Contacts**, **Tasks**, **Calendar** and **Notes**) that you wish to synchronize with the device, and choose whether you want to synchronize manually or automatically.
- 4 On the Dell PC Suite window, click the **Synchronize Now** icon to start synchronization.

To back up or restore device data using Backup Manager

To prevent data loss from your device, you can use Backup Manager to create a backup of your device data on your computer, and then import the backup data back onto the device. It is recommended that you make backups of your device data on a regular basis.

- 1 On the Dell PC Suite window, click the **Backup Manager** icon. The **Backup and Restore Wizard** opens.
- 2 You can either:
 - Let the Backup and Restore Wizard guide you through a backup or restore process.
 - Click the **Advanced** button, and then click the **Backup...** or **Restore...** button to perform a backup or restore task in the Advanced mode.



NOTE: To start a restore task in the Advanced mode, you must first select a backup file from the **Previously created backups:** list.







NOTE: To specify where on the computer the backup file is stored, click **T**ools on the menu bar at the top → **O**ptions → **S**ave To.

To Quit Dell PC Suite

Right-click the icon  at the bottom right of the compute screen, and then click **E**xit.

Playing Videos on HDMI Devices

- 1 Insert the 30-pin connector on the bottom of your device into the 30-pin connector on the home dock.
- 2 Connect your device to a HDMI device for example a HDMI monitor or TV using a HDMI data cable.
- 3 Touch the Application button  → **Photos & Videos** .
- 4 Touch a video thumbnail to start playback of the video.
- 5 The device screen displays **Video out** to ask for your confirmation. Touch **Yes** to play the video on the display of the connected HDMI device. Touch **No** if you want to play the video on the device.
- 6 To switch video playback between the device screen and the HDMI display, touch the Menu button  → **Change video out**.
- 7 To control playback, use these controls on the device screen:
 - Touch the  button to pause and the  button to resume playback.
 - Touch or drag the yellow playback progress bar to rewind or fast-forward the video.









NOTE: The device supports WMV9/MPEG-4/H264/H263 video files through HDMI output.



NOTE: HDMI output resolution: 720p.

Troubleshooting





Problem	Possible causes	Possible solutions
Call-related problems		
SIM card error	SIM card malfunction or damage.	Take the SIM card to your service provider for testing.
	The SIM card is inserted improperly.	Insert the SIM card properly.
	Dirt or dust on the SIM card's metal contacts.	Use a soft, dry cloth to clean the SIM card's metal contacts.
Poor reception	The network signal is too weak at your current location, for example, in a basement or near a tall building. Wireless transmissions can not effectively reach it.	Move to a location where the network signal can be properly received.
	The network is busy at the current time (for example, during peak times, there may be too much network traffic to handle additional calls).	Avoid using the device at such times, or try again after waiting a short time.
	You are too far away from a base station for your service provider.	You can request a service area map from your service provider.

Problem	Possible causes	Possible solutions
You cannot make outgoing calls	The SIM card is not installed.	Install a valid SIM card in your device.
	Poor signal.	Move to an open space, or if you are inside a building, move closer to a window.
	Your device is in Airplane mode with no wireless connectivity.	Touch the status area on the status bar and clear the Airplane mode check box.
	You have enabled the Call barring feature.	Touch the Home button  → Menu button  → Settings → Call settings → Additional call settings → Call barring → Deactivate all.
	You have enabled Fixed Dialing Numbers.	Touch the Home button  → Menu button  → Settings → Call settings → Fixed Dialing Numbers. Disable Fixed Dialing Numbers (FDN).
You cannot answer incoming calls	Poor signal.	Move to an open space, or if you are inside a building, move closer to a window.
	Your device is in Airplane mode with no wireless connectivity.	Touch the status area on the status bar and clear the Airplane mode checkbox.
	You have enabled the Call barring feature.	Touch the Home button  → Menu button  → Settings → Call settings → Additional call settings → Call barring → Deactivate all.
Unable to add contacts to the device	Memory for storing contacts is already full.	Delete unnecessary contact information from the device.
Echo or noise	Poor network trunk quality on the part of your service provider, or poor local telephone line quality.	Hang up and dial again. You may be switched to a better-quality network trunk or phone line.

Problem	Possible causes	Possible solutions
Noises during a call	You may be near a strong electromagnetic source (such as a TV, a microwave oven, etc.) during a call.	Move to another location to reduce the interference effects.
You cannot enable certain call features	Your service provider does not support these features, or you have not applied for services that provide these features.	Contact your service provider.
PIN Code is blocked	You have entered an incorrect PIN code three consecutive times.	Contact your service provider. If the service provider provides the SIM card's PUK code, use the PUK code to unlock the SIM card.
System problems		
Battery does not charge	The battery or battery charger is damaged.	Contact the dealer.
	The device's temperature is below 0°C or higher than 45°C.	Adjust the battery charging environment to avoid extreme temperatures.
	Poor contact between the battery and charger.	Check all connectors to ensure that all connections have been properly made.
Unable to turn the device on.	The battery is empty.	Charge the device.
	The back cover has come off.	Ensure that the back cover is firmly secured to the device.
	Battery contacts are not clean.	Seek your dealer's help to clean the contacts.
The device turns off automatically	The back cover has come off.	Ensure that the back cover is firmly secured to the device.

Problem	Possible causes	Possible solutions
Shortened standby time	The length of standby time is affected by your service provider's system configuration. The same device used with different service providers' systems does not have the same length of standby time.	If you are located in an area where the network signal is weak, temporarily turn off your device.
	The battery is depleted. In high-temperature environments, battery life will be shortened.	Use a new battery.
	If you are not able to connect to the network, the device will continue to send out signals as it attempts to locate a base station. Doing this consumes battery power and consequently shortens standby time.	Change your location to one where the network is accessible, or temporarily turn off your device.
Messaging problems		
Unable to send or receive text messages.	Your device is in Airplane mode with no wireless connectivity.	Touch the status area on the status bar and clear the Airplane mode checkbox.
	The signal strength is not strong enough.	Try moving to a different location for better signal reception.

Problem	Possible causes	Possible solutions
Unable to send or receive multimedia messages.	Your device is in Airplane mode with no wireless connectivity.	Touch the status area on the status bar and clear the Airplane mode checkbox.
	No MMS service is available.	Subscribe to the MMS service from your network service provider.
	Your MMS settings are not configured properly.	Check your network connection, and confirm with your network service provider if your MMS settings are configured correctly.
	Not enough space left on your device memory.	Check if there is enough space on your device memory. Delete useless data to free space if necessary.
Unable to send or receive e-mail.	The Internet connection or the e-mail setting is not configured properly.	Check your network connection, and confirm with your e-mail service provider if your e-mail setting has been configured correctly.
Internet problems		
Unable to connect to the network.	Invalid SIM card.	Contact your service provider.
	You are not within the network's service area.	Check the service area with your service provider.
	Poor signal.	Move to an open space or if you are inside a building, move closer to a window.
Media problems		

Problem	Possible causes	Possible solutions
Windows Media Player on my computer cannot play the sounds of the video captured using the device.	The device records video sounds in amr format, but Windows Media Player does not support amr decoding.	Play the video using a video player with the amr decoder, such as QuickTime.
Should it be necessary, you can calibrate your touch screen as follows		
<ol style="list-style-type: none"> <li data-bbox="165 411 988 467">1 Press and hold the power button  and then touch the Power off option on the screen to turn off the device. <li data-bbox="165 480 947 536">2 Simultaneously press and hold the volume up button  and volume down button . <li data-bbox="165 549 994 604">3 Without releasing the volume buttons, press and hold the power button , until the device turns on the configuration screen. <li data-bbox="165 617 949 673">4 Press the volume buttons to move the highlight bar on the screen to the Screen calibration option. <li data-bbox="165 686 855 710">5 Touch the Camera button  to start the touch screen calibration. <li data-bbox="165 718 468 742">6 Wait for the device to reboot. 		

Index

A

- Airplane Mode, 56
- Alarm Clock, 112
- Amazon MP3, 87
- Android Market, 83
- Applications
 - Definition, 18
 - Erase data, 51
 - Favorites bar, 28
 - Navigate, 28
 - Recently used, 29
 - Shortcuts, 29

B

- Back cover
 - Close, 13
 - Remove, 11
- Backup
 - data, 121
- Battery
 - Charge, 13
 - Insert, 12
- Bluetooth, 104

C

- Calculator, 114

Calendar, 111

Calling, 30

Camera, 97

 Manage pictures, 98

 Manage videos, 102

 Settings, 100

 Shoot videos, 101

 Take pictures, 97

Charging, 13

Contacts, 48

 Add, 49

 View, 50

Controls, 8

 Touch screen, 15

D

Data

 Backup and restore, 121

Date, 90

Device

 Protect, 93

 Reset, 52

 Setup, 11

 Turn off, 14

 Turn on, 14

Device overview, 8

Disable all connections, 56

Display settings, 88

E

E-mail, 62
Erase all data, 52

F

Facebook, 48
Factory reset, 52

G

Gmail, 64
Google Account
 Setup, 64
Google Maps, 71
Google Search, 46
Google Talk, 67

H

Home Screen, 19
 Add, 19
 Customize, 20
 Delete, 19

K

Keyboard, 42

L

Language, 92

M

Maps, 71
microSD, 102
 Format, 51
 Install, 12
 Set as USB drive, 102
 Turn off USB storage, 103
Mobile networks
 Data connection, 53
Music, 108
 Create a playlist, 110
 Playback, 109

N

Notes, 118

O

On-Screen Keyboard, 42
Outlook Notes, 118
Outlook Tasks, 116

P

Package Contents, 7
PC Suite, 120

Photos & Videos, 106

PIN

Change, 96

Enable, 95

Pop-Up menu, 42

Q

Quickoffice, 118

R

Recorder, 114

Restore

Data, 121

Ringtone, 89

RSS, 47

S

Screen

Turn off/on, 14

Screen Orientation, 18

Screen Unlock Pattern, 93

Create, 93

Enable/disable, 94

Shortcuts, 29

Add, 21

Definition, 18

SIM card

Insert, 11

SIM Manager, 117

Software upgrade, 52

Sound, 89

Status bar, 25

Icons, 26

Synchronize Google Data, 86

Synchronize with PC

Use PC Suite, 120

T

Tasks, 116

Text Messages, 36

Compose

MMS, 37

SMS, 36

Receive, 40

Time, 90

Time zone, 90

Touch screen, 15

Troubleshooting, 124

Twitter, 48

V

Videos

Play on HDMI devices, 123

Voice Control, 115

W

Web

- Applications, 64
- Bookmarks, 61
- Browse, 57
- Connection, 53
- Widgets, 46
 - Add, 22
 - Definition, 18
 - Facebook, 48
 - Google Search, 46
 - RSS, 47
 - Twitter, 48
- Wi-Fi, 55

Y

- YouTube, 81