

THANK YOU

We are grateful you chose using our land mobile radio. We believe this easy-to-use transceiver will provide dependable communications to keep personnel operating at peak efficiency.

All transceivers we produce incorporate the latest in advanced technology. As a result, we feel strongly that you will be pleased with the quality and features of this product.

MODELS COVERED BY THIS MANUAL

3308 : 16-channel VHF FM Transceiver

3308 : 16-channel UHF FM Transceiver

NOTICES TO THE USER

- Government law prohibits the operation of unlicensed radio transmitters within the territories under government control.
- Illegal operation is punishable by fine or imprisonment or both.
- Refer service to qualified technicians only.

Safety

- It is important that the operator is aware of and understands hazards common to the operation of any transceiver.
- We do not guarantee the safety and operation of the transceiver when using accessories and/or attachments not sold by our company.



EXPLOSIVE ATMOSPHERES (GASES, DUST, FUMES, etc.)

Turn off your transceiver while taking on fuel, or while parked in gasoline service stations.

PRECAUTIONS

Observe the following precautions to prevent fire, personal injury, and transceiver damage.

- Do not modify or attempt to adjust this transceiver for any reason.
- Do not expose the transceiver to long periods of direct sunlight, nor place it close to heating appliances.
- Do not place the transceiver in excessively dusty, humid, and/or wet areas, nor on unstable surfaces.
- If an abnormal odor or smoke is detected coming from the transceiver, switch OFF the power immediately and remove the battery pack from the transceiver.

UNPACKING AND CHECKING EQUIPMENT

Carefully unpack the transceiver. We recommend that you identify the items listed in the following table before discarding the packing material. If any items are missing or have been damaged during shipment, file a claim with the carrier immediately.

Supplied Accessories

Item	Quantity
Antenna	1
Hand strap	1
Speaker/microphone jack cover	1
Belt clip	1
Screw set	1
Instruction manual	1

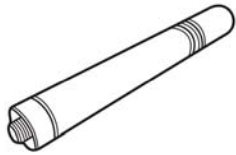

Antenna

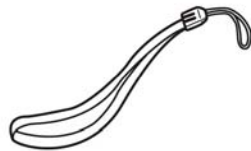

Hand strap



Speaker/microphone
jack cover

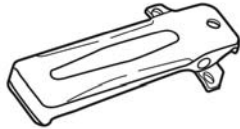

Belt clip



Screw set



Instruction manual

PREPARATION

Notice for Charging The Ni-MH Battery Pack

The battery pack is not charged at the factory; charge it before use. Initially charging the battery pack after purchase or extended storage (greater than 2 months) will not bring the battery pack to its normal operating capacity. After repeating the charge/discharge cycle two or three times, the operating capacity will increase to normal.

CAUTION

- ◆ Do not recharge the battery pack if it is already fully charged. Doing so may cause the life of the battery pack to shorten or the battery pack may be damaged.
- ◆ After recharging the battery pack, disconnect it from the charger. Charging the battery pack for more than 5 days may reduce the battery pack life due to overcharging.

Note:

- ◆ The ambient temperature should be between 41 and 104°F (5 and 40°C) while charging is in progress. Charging outside this range may not fully charge the battery.
- ◆ Always switch OFF the transceiver equipped with a Ni-MH battery pack before charging. Using the transceiver while charging its battery pack will interfere with correct charging.
- ◆ The battery pack life is over when its operating time decreases even though it is fully and correctly charged. Replace the battery pack.

INSTALLING/REMOVING THE BATTERY PACK

CAUTION

- ◆ Do not short the battery terminals or dispose of the battery by fire.
- ◆ Never attempt to remove the casing from the battery pack.

1. Align the battery pack with the back of the transceiver, then press the battery pack and transceiver firmly together until the release latch on the base of the transceiver locks.

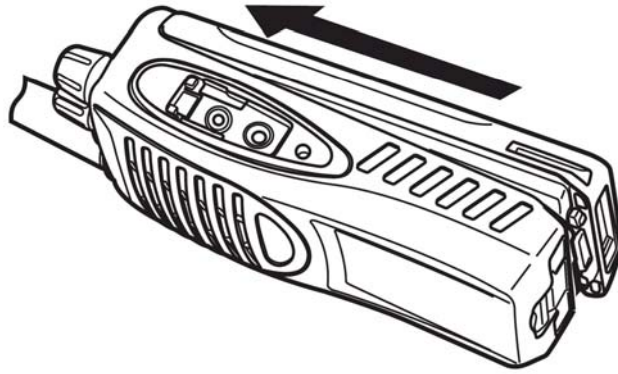

2. To remove the battery pack, lift the safety catch on the base of the transceiver, then press the release latch underneath the safety catch.

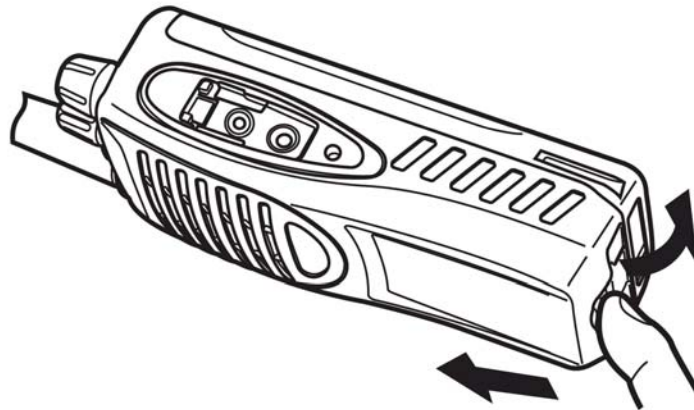

3. While pressing the release latch, pull the battery pack away from the transceiver.

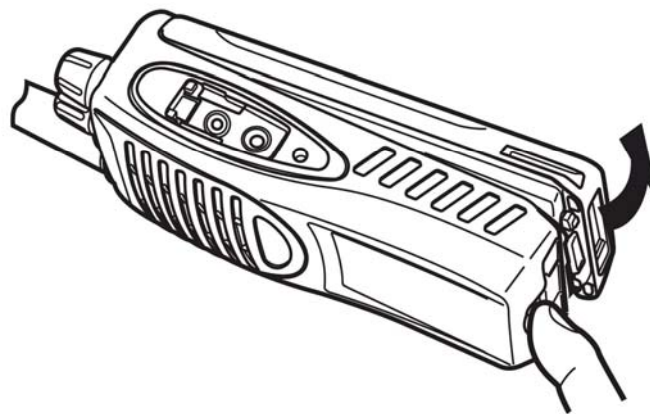

INSTALLING THE ANTENNA

Screw the antenna into the connector on the top of the transceiver holding the antenna at its base and turning it clockwise until secure.

Note: The antenna is neither a handle a key ring retainer, nor a speaker/ microphone attachment point. Using the antenna in these ways may damage the antenna and Degrade your transceiver's performance.

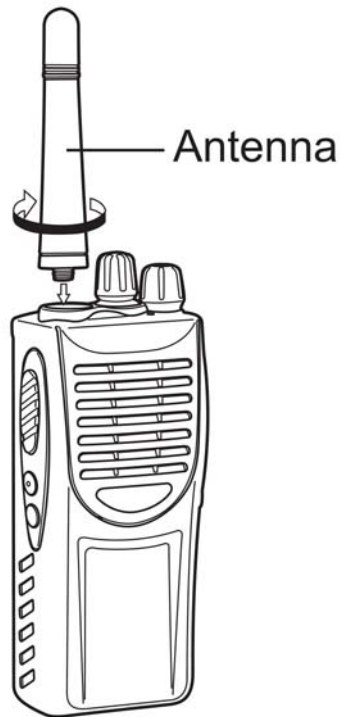

INSTALLING THE BELT CLIP

If necessary, attach the belt clip using the two supplied 3 x 8 mm screws.

Note: If the belt clip is not installed, its mounting location may get hot during continuous transmission or when left sitting in a hot environment.

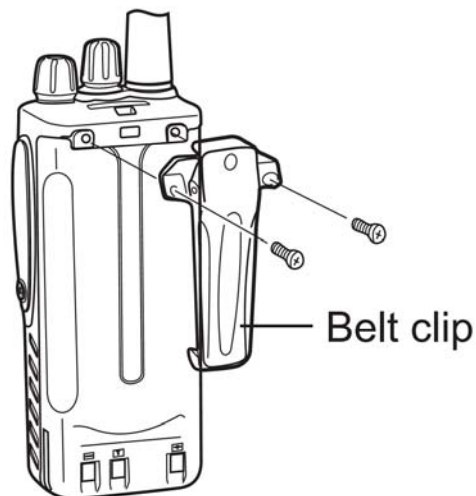

CAUTION

- ◆ Do not use glue which is designed to prevent screw loosening when installing the belt clip, as it may cause damage to the transceiver.
- ◆ Acrylic ester, which is contained in these glues, may crack the transceiver's back panel.

INSTALLING THE COVER OVER THE SPEAKER/ MICROPHONE JACKS

If you are not using a speaker/microphone, install the cover over the speaker/microphone jacks using the supplied 3x6mm screw

Note: To keep the transceiver water resistant, you must cover the speaker/microphone jacks with the supplied cover.

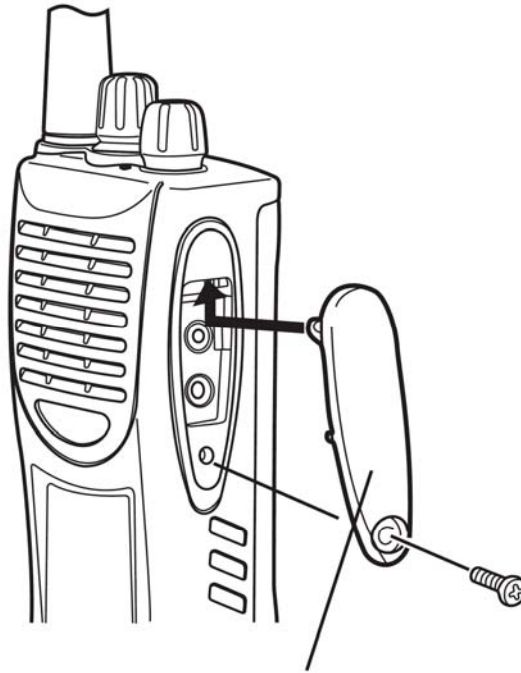

Speaker/microphone jack cover

INSTALLING THE OPTIONAL SPEAKER/MICROPHONE (OR HEADSET)

1. Insert the speaker/microphone (or headset) plugs into the speaker/microphone jacks.

Note: The transceiver is not fully water resistant while using the speaker/microphone.

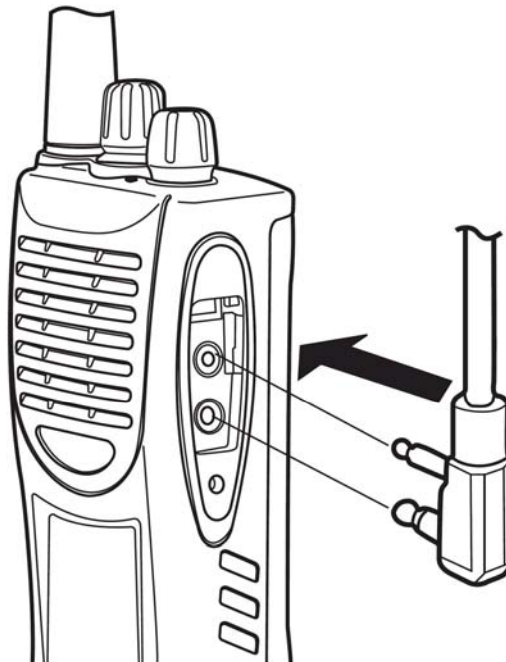

INSTALLING THE HAND STRAP

1. Slide the small loop of the hand strap through the eyelet on the upper rear of the transceiver.

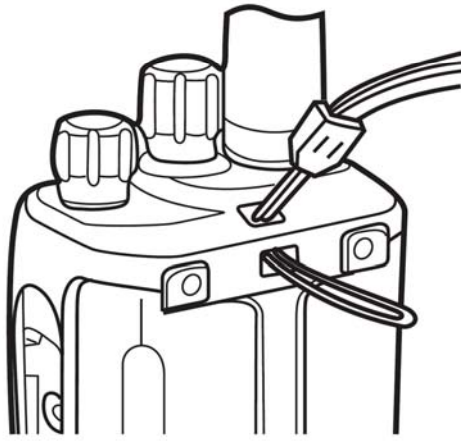

2. Pull the entire hand strap through the small loop to secure the hand strap in place.

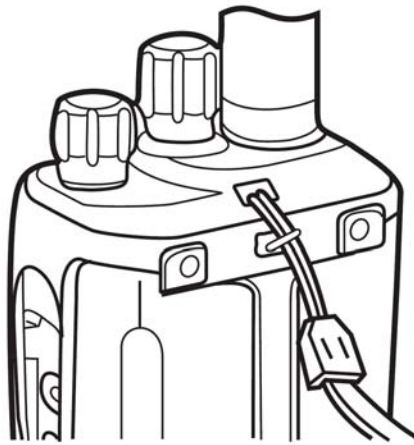

GETTING ACQUAINTED

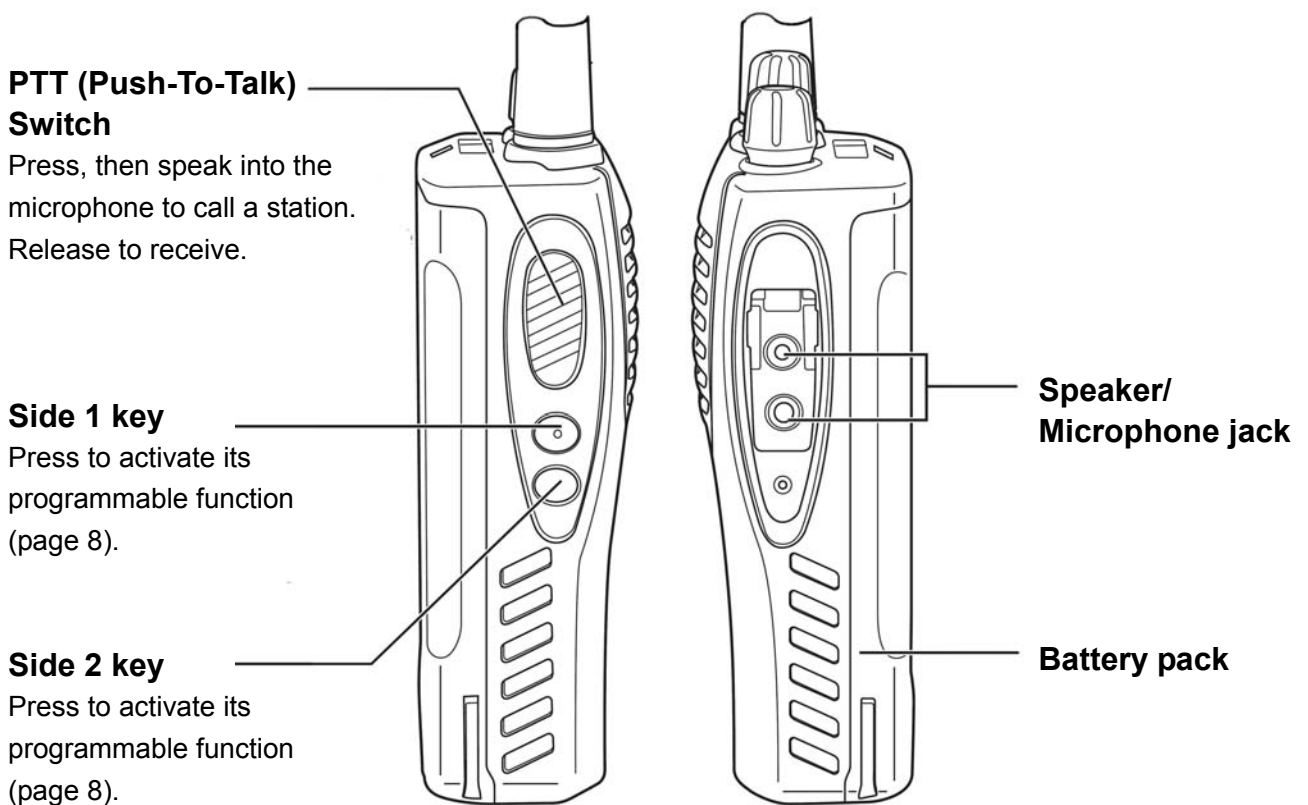
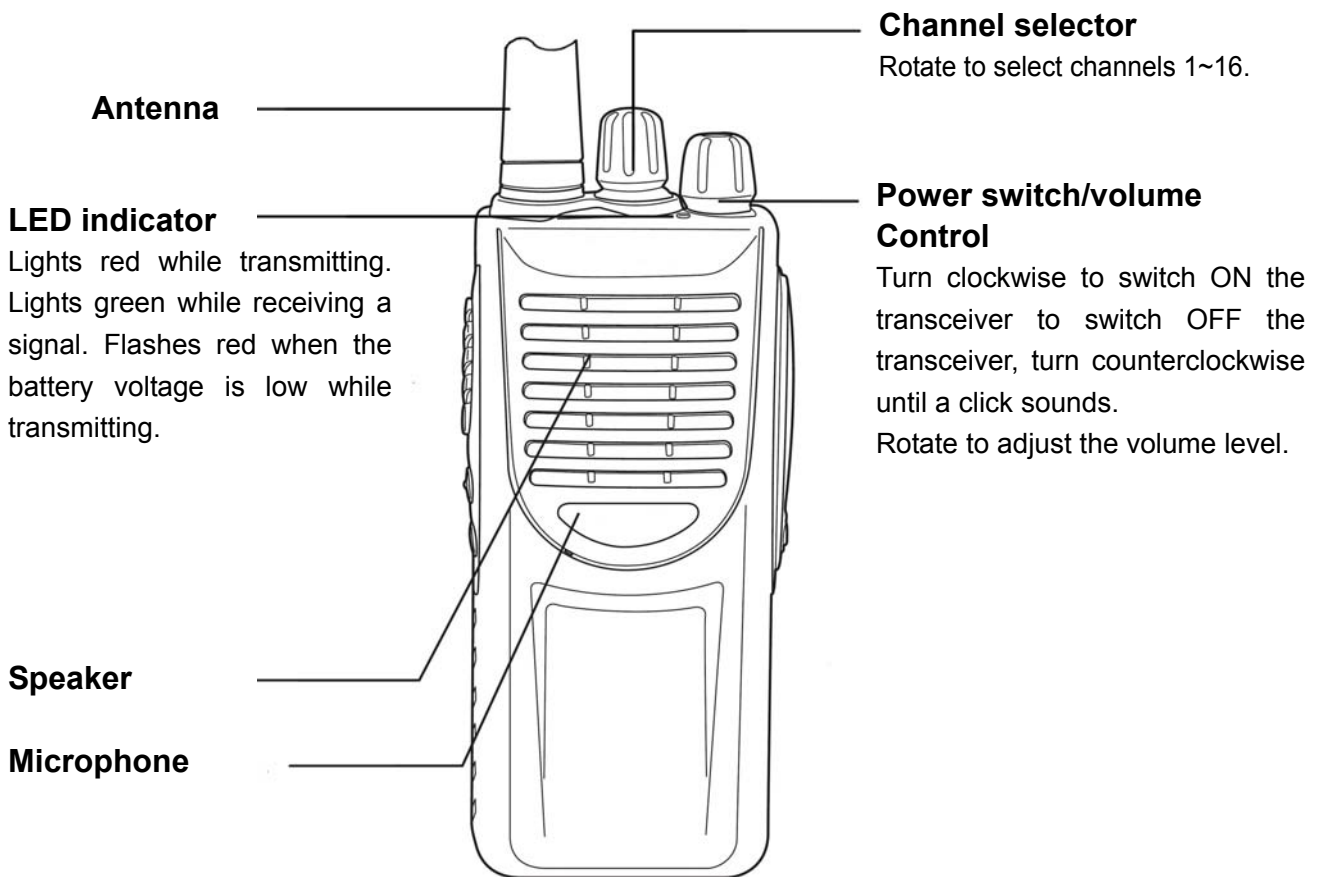

PROGRAMMABLE AUXILIARY FUNCTIONS

Your dealer can program each of the **Side 1** and **Side 2** keys with one of following auxiliary functions. Refer to their descriptions, starting on page 9.

- Key Lock
- Key Lock (with Backup)
- Monitor
- Monitor Momentary
- None (No function) (default setting for **Side 1** key)
- Scan
- Scan + Temporary Delete
- Squelch Off
- Squelch Off Momentary (default setting for **Side 2** key)
- Temporary Delete

BASIC OPERATIONS

1. Turn the **Power switch/Volume** control clockwise to switch the transceiver power ON.
 - A beep sounds if enabled by your dealer.

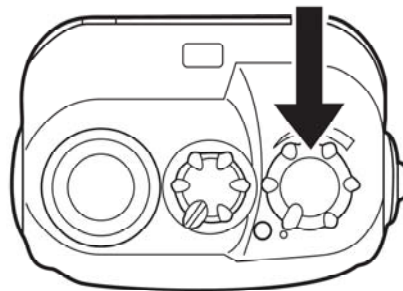

2. Press the key programmed with the **Monitor** or **Squelch Off** function to hear background noise, then rotate the **Power switch/Volume** control to adjust the volume.

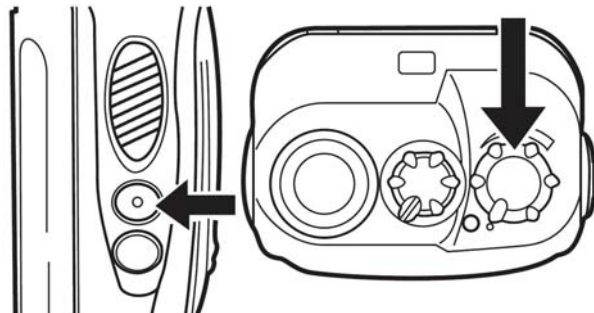

3. Rotate the **Channel** selector to select your desired channel.
 - When you receive an appropriate signal, you will hear audio from the speaker.

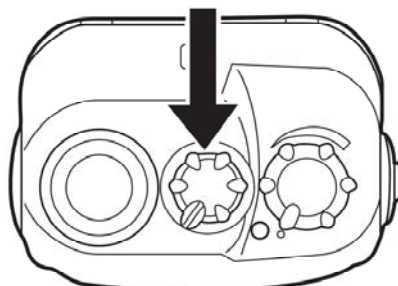

4. To make a call, press and hold the **PTT** switch, then speak into the microphone using your normal speaking voice. 1.5 inches (3 to 4 cm) from your lips.
 - Hold the microphone approximately

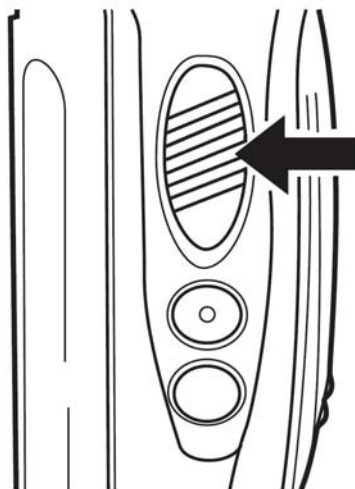

5. Release the **PTT** switch to receive.

 **CAUTION**

- ◆ When the battery pack voltage becomes too low, transmission will stop and an alert tone will sound. See "Low Battery Warning" on page 13.

ADVANCED OPERATIONS

The following functions are programmable by your dealer, as described on page 8.

KEY LOCK

Press and hold the key programmed as **Key Lock** for 1 second to lock/unlock the transceiver keys. The following keys/functions can still be used when Key Lock is active: Key Lock, Monitor, Monitor Momentary, PTT, Squelch Off, Squelch Off Momentary, and Volume.

If the key is programmed "with backup", when the transceiver power is turned OFF and then ON again, the keys remain locked.

Otherwise, when the transceiver power is turned OFF and then ON again, the Key Lock function will be cancelled.

MONITOR/SQUELCH OFF

You can use the key programmed as **Monitor** or **Squelch Off** to listen to weak signals that you cannot hear during normal operation, to deactivate channel signalling, and to adjust the volume when no signals are present on your selected channel.

- **Squelch Off:** Momentarily press to hear background noise. Press the key again to return to normal operation.
- **Squelch Off Momentary:** Press and hold to hear background noise. Release the key to return to normal operation.
- **Monitor:** Momentarily press to deactivate QT, DQT Signal, Press the key again to return to normal operation.
- **Monitor Momentary:** Press and hold to deactivate QT, DQT Signal, Release the key to return to normal operation.

SCAN

Scan is useful for monitoring signals on the transceiver channels. When scanning, the transceiver checks for a signal on each channel and only stops if a signal is present. The transceiver will remain on a busy channel until the signal is no longer present. Your dealer programs the delay time between signal drop-out and Scan resumption. If a signal is received during the delay time, the transceiver will remain on the same channel.



You can only use Scan if your dealer has programmed at least 2 channels and they are not locked out of Scan.

To start scanning, momentarily press the key programmed as either **Scan** or **Scan + Temporary Delete**.

- Scanning starts from the current channel and ascends through the channel numbers.
- The LED indicator flashes green.
- When a signal is received on a channel and signaling matches, the LED indicator lights green.

To end Scan, press the **Scan** or **Scan + Temporary Delete** key again.

Priority Scan

If enabled, a priority channel is set up one of two ways:

- Your dealer may set up a fixed priority channel on your transceiver.
- You can select your own priority channel, prior to scanning, using the **Channel** selector.
- Your dealer programs the delay time between signal drop-out and scan resumption.

Temporary Delete

If a key is programmed with the Temporary Delete or **Scan + Temporary Delete** function, you can temporarily remove specific channels from the scanning sequence during Scan. When Scan stops at a channel, you can remove that channel from the scanning sequence by pressing and holding the key programmed as **Temporary Delete** or **Scan + Temporary Delete** for 1 second.

- You cannot delete the Priority channel, if one has been set up.
- You cannot delete a channel if there will be less than 2 channels available for scanning remaining.
- To add the channel back into the Scan list, simply exit Scan mode or switch the transceiver OFF and then ON again.

Revert Channel

During Scan, pressing the **PTT** switch to transmit will cause the transceiver to select the revert channel. Your dealer can program the revert channel using one of the following methods:

- **Selected:** The last channel selected is assigned as the new revert channel.
- **Selected + Talkback:** If the channel has been changed during Scan, the newly selected channel is assigned as the new revert channel. However, the transceiver also transmits on the channel where Scan is currently paused.
- **Priority:** If your dealer has programmed a Priority channel, it is the revert channel.
- **Priority + Talkback:** If your dealer has programmed a Priority channel, it is the revert channel. However, the transceiver also transmits on the channel where Scan is currently paused.

VOICE OPERATED TRANSMISSION (VOX)

VOX operation allows you to transmit hands-free. This feature must first be activated by your dealer, and can only be used if you are using a supported headset.

When operating VOX, you must set a VOX Gain level. This setting allows the transceiver to recognize sound levels. If the microphone is too sensitive, it will begin transmitting when there is noise in the background. If it is not sensitive enough, it will not pick up your voice when you begin speaking. Be sure to adjust the VOX Gain level to an appropriate sensitivity to allow smooth transmission.

To activate VOX and set the VOX Gain level, perform the following steps:

1. Connect the headset to the transceiver (page 5).
 - The VOX function does not activate when a headset is not connected to the accessory terminal of the transceiver.

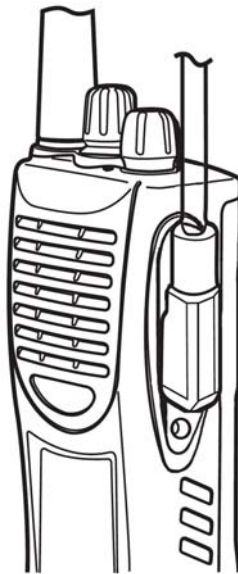

2. With the transceiver power OFF, press and hold the **Side 1** key while turning the transceiver power ON.

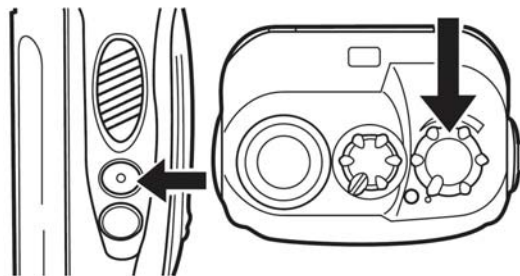

3. Continue to hold the **Side 1** key until a beep sounds.
 - The LED indicator lights orange.
 - When the **Side 1** key is released, the transceiver announces the VOX Gain level.

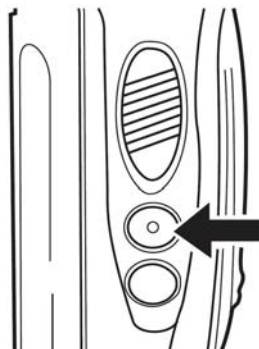

4. Press the **Side 1** key to increase the VOX Gain level and the **Side 2** key to decrease the level.
- The VOX Gain can be adjusted from levels 1 to 10 and OFF.
 - The transceiver announces the VOX Gain level as you adjust it. If OFF is selected, a beep sounds.

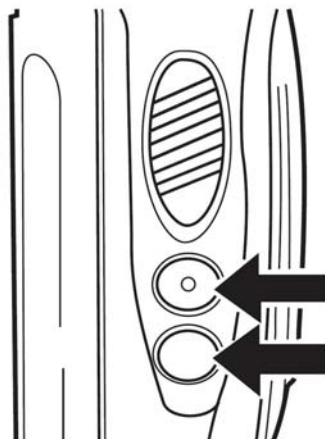

5. Press the **PTT** switch to save the setting.
- A beep will sound.
 - The transceiver announces the new VOX Gain level.

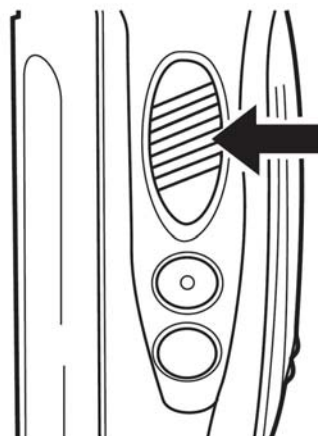

6. Turn the transceiver power OFF and the ON again to activate VOX.

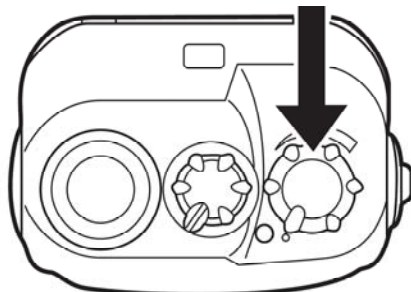

NOTE

- ◆ If a speaker/microphone is connected to the transceiver while the VOX function is switched ON and the VOX Gain level is configured to a higher, more sensitive level, louder received signals may cause the transceiver to start transmission.
- ◆ When you operate the VOX function, you must use an optional KHS-1 or KHS-21 accessory.

BACKGROUND OPERATIONS

TIME-OUT TIMER (TOT)

The purpose of the Time-out Timer is to prevent any caller from using a channel for an extended period of time. If you continuously transmit for a period of time that exceeds the programmed time set by your dealer (default is 1 minute), the transceiver will stop transmitting and an alert tone will sound. To stop the tone, release the **PTT** switch. Your dealer can program a warning function to alert you before the TOT expires. Continuously transmitting for the time specified by your dealer will cause the warning tone to sound.

BUSY CHANNEL LOCKOUT (BCL)

When activated, BCL prevents you from interfering with other parties who may be using the same channel that you selected. Pressing the **PTT** switch while the channel is in use will cause your transceiver to emit an alert tone and transmission will be inhibited (you cannot transmit). Release the **PTT** switch to stop the tone and return to receive mode.



Ask your dealer for an explanation on how BCL functions when using QT, DQT.

BATTERY SAVE

If activated by your dealer, the Battery Save function will decrease the amount of power used when a signal is not being received and no operations are being performed (no keys are being pressed, and no switches are being turned). While the channel is not busy and no operation is performed for 5 seconds, Battery Save turns ON. When a signal is received or an operation is performed, Battery Save turns OFF.

LOW BATTERY WARNING

Low Battery Warning alerts you when the battery needs to be recharged or replaced.

While operating the transceiver, if the battery power becomes low, an alert tone will sound every 30 seconds and the LED indicator will blink red. Replace or recharge the battery pack.

CHANNEL ANNUNCIATION

When changing the channel using the Channel selector, an audio voice will announce the selected channel number, after you stop changing the channel. (Channel Annunciation can be activated or deactivated by your dealer.)

QUIET TALK (QT)/DIGITAL QUIET TALK (DQT)

Your dealer may have programmed QT or DQT signalling on your transceiver channels. A QT tone/DQT code is a subaudible tone/code which allows you to ignore (not hear) calls from other parties who are using the same channel. When a channel is set up with a QT tone or DQT code, squelch will only open when a call with a matching tone or code is received. Likewise, signals that you transmit will only be heard by parties whose QT/DQT signalling matches yours.

If a call with a different tone or code is made on the same channel you are using, squelch will not open and you will not hear the call. This allows you to ignore (not hear) these calls.

Although it may seem like you have your own private channel while using QT/DQT, other parties can still hear your calls if they set up their transceiver with the same tone or code as you do.

Warning:

This device complies with Part 15 of the FCC Rules. Operation is subject to the following two conditions: (1) this device may not cause harmful interference, and (2) this device must accept any interference received, including interference that may cause undesired operation.

Note: This equipment has been tested and found to comply with the limits for a Class B digital device, pursuant to part 15 of the FCC Rules. These limits are designed to provide reasonable protection against harmful interference in a residential installation. This equipment generates, uses and can radiate radio frequency energy and, if not installed and used in accordance with the instructions, may cause harmful interference to radio communications. However, there is no guarantee that interference will not occur in a particular installation. If this equipment does cause harmful interference to radio or television reception, which can be determined by turning the equipment off and on, the user is encouraged to try to correct the interference by one or more of the following measures:

- Reorient or relocate the receiving antenna.
- Increase the separation between the equipment and receiver.
- Connect the equipment into an outlet on a circuit different from that to which the receiver is connected.
- Consult the dealer or an experienced radio/TV technician for help.

FCC 15.21

Modifications not authorized by the manufacturer may void users authority to operate this device.