

Package and Product Designed in U.S.A.

MADE IN CHINA

# AnyToneTech.com



Copyright © 2015 by AnyTone Tech

All rights reserved. No part of this publication may be reproduced, distributed, or transmitted in any form or by any means without the permission of AnyTone Tech

**AnyTone**<sup>®</sup>  
*tech*

**OBLTR-8R**

THE OBLITERATOR

**TERMN-8R**

THE TERMINATOR

**USER'S MANUAL**





## **THANK YOU FOR TRUSTING US WITH YOUR RADIO NEEDS !**

*AnyTone*<sup>tech</sup> transceivers provide you with reliable, clear, and precise communications. This transceiver includes innovative DSP (digital signal processing) technology - allowing for easy integration into all environments. We encourage you to read through the manual to understand the various functions to get the most from your handset.

The transceiver includes 200 programmable channels, The transceiver also allows for Dual PTT functions, 51 groups of CTCSS encode/decode, 1 group of user-defined CTCSS encode/decode, 1024 groups of DCS encode/decode, DTMF encode/decode, and many more features.

This radio is a meticulously built and a functional hand-held intended for every radio operator.

### **Radio Versions**

**OBLTR-8R:** FM Transceiver

**TERMN-8R:** FM Transceiver

## **THIS MANUAL IS FOR:**

### **OBLTR-8R**

OBLTR-8R Programming Software: OBLTR-8R\_Setup\_1.01.exe

### **TERMN-8R**

TERMN-8R Programming Software: TERMN\_8R\_Setup\_1.01.exe

## **USB PROGRAMMING PRECAUTION**

When programming the transceiver, first read from the radio, before modifying the frequencies data and settings. This will prevent errors caused from incompatible files.

## WARNINGS

*AnyTone<sup>®</sup>*<sub>tech</sub> transceivers are intelligently designed with advanced technologies. The following tips are required to prevent voiding warranty and understanding the safety of transceiver usage.

1. Keep the transceiver and all accessories away from children.
2. Do not try to open or modify the transceiver without permission. Irresponsible operation of the transceiver may also cause damage.
3. Use only *AnyTone<sup>®</sup>*<sub>tech</sub> approved batteries and chargers.
4. Use the provided antenna for communication.
5. Avoid exposing the radio to excess heat (such as direct sunlight) for extended periods or storing your transceiver in a hot location. High temperatures do shorten the life of electronic devices.
6. Do not store the radio in dusty, dirty, or damp areas.
7. Keep the radio dry. Do not wash radio with chemicals or detergents.
8. Do not transmit without the provided antenna.
9. When using this transceiver, we recommend transmitting for 1 minute then receiving for 1 minute. Continuous transmissions for a long time may over-heat the transceiver. If the transceiver is warm to the touch; do not set it by objects (such as plastic) that could melt.
10. If any abnormal smell or smoke comes from the transceiver, immediately shut off the power and remove the battery from the radio body. Then contact your local *AnyTone<sup>®</sup>*<sub>tech</sub> dealer.

### NOTE:

The above tips apply to your *AnyTone<sup>®</sup>*<sub>tech</sub> transceiver's accessories as well. If your accessories don't operate normally, please contact your local *AnyTone<sup>®</sup>*<sub>tech</sub> dealer for assistance.

Use of third-party/ after-market accessories are not guaranteed by *AnyTone<sup>®</sup>*<sub>tech</sub> and may void the warranty and/or safety of the transceiver

# ◦ TABLE OF CONTENTS

<b>UNPACKING</b> .....	01
Supplied Accessories .....	01
<b>STANDARD ACCESSORIES/ADDITIONAL ACCESSORIES</b> .....	02
Standard Accessories.....	02
Additional Accessories.....	02
<b>BATTERY INFORMATION</b> .....	03
Charging Operation.....	03
Battery Charger Type.....	03
Notice for Charging Battery.....	03
How to Charge.....	04
Charging Prompts Explained.....	06
How to Store the Battery.....	06
<b>INSTALLATION &amp; CONNECTION</b> .....	07
Installing / Removing the Battery.....	07
Installing / Removing the Antenna.....	07
Installing / Removing the Belt Clip.....	08
Installing the Additional Speaker/ Microphone (Optional).....	08
<b>GETTING ACQUAINTED</b> .....	09
LCD Display.....	09
<b>BASIC OPERATIONS</b> .....	12
Turn the Radio On & OFF.....	12
Adjusting Volume.....	12
Switch between Channel mode and VFO mode.....	13
Channel Adjusting.....	13
Frequency Adjusting.....	14

## ◦ TABLE OF CONTENTS

Receiving.....	14
Transmitting.....	15
Emergency Alarm.....	15
Side Key [PF1] Setup and Use.....	15
Side Key [PF2] Setup and Use.....	17
Add a channel.....	18
Delete a channel.....	18
<b>SHORTCUT OPERATIONS</b> .....	19
Add/Cancel Optional signal decode function.....	19
CTCSS/DCS Scan.....	20
Offset Frequency Direction Setup.....	20
Frequency/Channel Scan.....	21
Channel Scan Skip.....	21
Frequency Reverse.....	21
TX Power selection.....	22
Talk Around function.....	22
DTMF code Transmit and Enquiry.....	22
Keypad lock.....	23
Single-band Switching.....	24
CTCSS/DCS Encode and Decode.....	24
MSK (Text) Signal Sending (TERMN-8R ONLY).....	25
<b>Function Menu Setup</b> .....	26
CTCSS/DCS Encode Setup.....	26
CTCSS/DCS Decode Setup.....	26
CTCSS/DCS Encode/Decode Synchronous Setup.....	27
5TONE encode group selection.....	28



## o TABLE OF CONTENTS

2TONE encode group selection .....	28
Optional signaling setup .....	29
2TONE decode group selection .....	30
MSK encode group selection(TERMN-8R ONLY).....	30
Squelch mode setup .....	31
Frequency step size setup .....	32
Wide / Narrow Band Selection.....	32
Frequency Reverse .....	33
Talk Around ON/OFF.....	33
Offset Frequency setup .....	34
Editing Channel name.....	34
Busy Channel Lockout.....	35
TX OFF.....	36
Sub band Display setup .....	37
Keypad Voice prompt setup .....	37
Time-Out-Timer (TOT).....	38
Voice Operated Transmission (VOX) Setup.....	38
VOX Delay Setup .....	39
Automatic Power Off Time setup .....	39
DTMF Transmitting Time Setup.....	40
Squelch level setup .....	40
Scanning Resume Time Setup.....	41
Scan Speed.....	42
Function Icon Stay Time Setup.....	43
LCD Backlight Setup.....	44
LCD Backlight Color Setup.....	44

Self ID inquiry .....	45
Tone Pulse Frequency Selection .....	45
Battery Save Setup .....	46
PF1 key Function Setup .....	47
PF2 key Function Setup .....	48
<b>ADVANCED FUNCTION OPERATIONS</b> .....	49
Display Mode Setup .....	49
Resume Factory Default .....	49
Public Usage Frequency Mode (FCC Part 95) .....	50
Optional Signaling (DTMF) .....	51
2TONE Calling .....	53
Optional signal (5TONE) .....	54
Communication Note (Caller ID/PTTID List) (ANI) .....	57
MSK ENCODE / DECODE and FHSS-Frequency Hopping (TERMN-8R ONLY) .....	57
Cloning Cable .....	59
<b>Programming software starting (Takes Windows XP system for example)</b> .....	61
<b>TECHNICAL SPECIFICATION</b> .....	62
<b>TROUBLE SHOOTING GUIDE</b> .....	65
<b>ATTACHED CHART</b> .....	67
CTCSS Frequency Chart .....	67
1024 groups DCS Frequency Chart .....	68
<b>FCC COMPLIANCE</b> .....	71
Usage of Your Transceiver on Part 95 (Public) Frequencies .....	71
<b>LIMITED WARRANTY (UNITED STATES)</b> .....	72
<b>ANYTONE TECH'S LETTER TO YOU</b> .....	73

## ○ UNPACKING

Carefully unpack the transceiver. We recommend that you identify the items listed in the following table before discarding the packaging.

If any items are missing or have been damaged during shipment, please contact your dealer immediately.

### ((( Supplied Accessories

Item	Number	Quantity
Antenna	QA09UV1	1
Li-ion Battery	QB-35L	1
Battery Charger	QBC-35L	1
AC Adaptor	QPS-01	1
Earpiece	HS03	1
Belt Clip	BC07	1
Instruction Manual		1

## STANDARD ACCESSORIES/ADDITIONAL ACCESSORIES

*AnyTone*  
tech

### Standard Accessories



Antenna\*1  
QA09UV1  
155/435MHz



Li-ion Battery  
QB-35L



Battery Charger  
QBC-35L



AC Adaptor  
(12V/500mA)  
QPS-01



Earphone  
HS03



Belt Clip  
BC07



Instruction  
Manual

**\*1.Note: For frequency band of antenna, please refer to label indicated in the bottom of the antenna.**

### Additional Accessories



USB Programming  
Cable PC03



Programming Software  
OBLTR-8R/TERMN-8R\_USA



Car Charger  
CPL03



Battery Pack for Car  
Charger CPS02

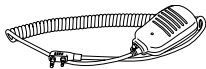

Handheld Microphone  
QHM22

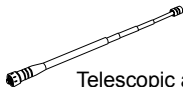

Telescopic antenna  
QA10UV



Cloning Cable  
CP04

## ○ BATTERY INFORMATION

### ((( Charging Operation

The battery is not charged at the factory, please charge it before your initial use. Charging the battery for the first time or charging it after extended storage (more than 2 months) may not bring the battery to its maximum operating capacity after the first charge. It may take repeating a full charge/discharge cycle for two or three times before the operating capacity reaches its maximum performance. It is recommended that you replace the battery pack when the battery can no longer hold a charge (even when you have it fully and correctly charged). Properly dispose of the expired battery pack.

### ((( Battery Charger Type

Please use our company's designated charger, after-market chargers could cause battery damage and in some cases could even explode the battery.

### ((( Notice for Charging Battery

- ▲ Do not short-circuit the charger. Never attempt to remove the casing from the battery. Tampering or modifying the battery and charger is not allowed and we are not responsible for anything that occurs from modification.
- ▲ The ambient temperature should be between 40°F and 100°F during charging.
- ▲ Always switch off the transceiver equipped with a battery before charging. A transceiver left on, will interfere with correct charging.
- ▲ To avoid interfering the charging procedure, do not cut off the power or take out the battery during a charge.

## ○ BATTERY INFORMATION

*AnyTone*  
tech

- ▲ Do not recharge the battery if it is already fully charged. This could shorten the life of the battery or damage the battery.
- ▲ Do not charge the battery or transceiver if it is damp or wet. Dry it before charging to avoid any danger.

**WARNING:**When keys, ornamental chains, or other metals contact or short the battery terminals, the battery could cause a shock or injury. If the battery terminals are allowed to short circuit, they will generate a lot of heat. Be careful when you bring or use a spare battery. Put the battery or radio into an insulated container. Do not put them into metal containers.

### (((How to Charge



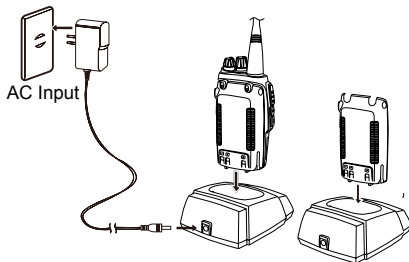

1. Plug the AC adapter into the AC outlet(100V-240V), then plug the cable of AC adapter into the DC jack, the indicator will light GREEN--- this means it is waiting to charge.
2. Slide the battery or transceiver with battery into the charger; make sure the battery terminals are in contact with the charging terminals well. The LED may begin flashing--- pre-charging begins.
3. It may pre-charge for about 5 minutes, In which once the LED stops flashing and turns into a solid RED--- the full charging has begun.
4. It may take about 5-6 hours to fully charge the battery, when the LED turns GREEN— it is fully charged.



## ○ BATTERY INFORMATION

**NOTE:** When charging a powered on transceiver equipped with battery, the LED will not turn to green to show the full charge status. Only when you turn off the transceiver, will the LED indicate normally. If the transceiver is powered on, it will continually consume energy. The charger cannot detect when the battery has been fully charged and will fail to indicate correctly.

### 5. Charging Process:

Status	LED
Standby (self-examine orange lights 1second when power on)	 Green light
Pre-charging (pre-charging stage)	 Red light flashes for about 5 minutes
Charging	 RED light for about 5.5 hours
Full charged (charge in constant voltage)	 Green light

### 6. LED Indicator:

STATUS	self-examine when power on	(No battery)	Pre-charging	Charge normally	Full Charged	Error
LED	Orange (for 1 second)	Green	Red light flashes for 5 minutes	Red	Green	Red flashes for a long time

**NOTE:** An Error means the battery is too hot or cold, the battery has short-circuited, or the charger has short-circuited.

### ((( Charging Prompts Explained

1. Self-examination: When plugging in your charger, the ORANGE light may flash for 1 second and go out. This means that the charger has passed its self-examination and it can charge the battery normally. If the light remains orange or the red light flashes this means the charger cannot pass its self-examination test and it will not charge the battery.
2. Trickle pre-charging: When the battery has been inserted into the charger and the RED light begins flashing, this means that the remaining voltage is very low. The charger will trickle charge the battery (pre-charging status), until the battery reaches a minimum charge. The charger will then automatically start the normal charging cycle. If the red light stops flashing immediately, this means that the remaining voltage is high enough to allow the charger to charge the battery normally.

**NOTE:** The time for Trickle pre-charging should not exceed 30 minutes. After 30 minutes, if the red indicator is still flashing, it means it is unable to charge battery. Check both the battery and charger for any issues.

### ((( How to Store the Battery

1. If the battery needs to be stored, the battery should be kept in the status of 50% discharge.
2. It should be kept in a cool and dry environment.
3. Keep away from hot places and direct sunlight.

#### WARNING

- ▲ Do not short circuit battery terminals.
- ▲ Never attempt to remove the casing from the battery pack.
- ▲ Never attach the battery to the radio in dangerous.
- ▲ Do not put the battery in a hot environment or throw it into fire.



## ◦ INSTALLATION & CONNECTION

### ((( Installing / Removing the Battery

#### ■ Installing the Battery:

1. Lay the battery to face the back of the radio.
2. Press the bottom of the battery, the latch in the bottom of the transceiver lock will release. After hearing a "click", the battery has been locked.



#### ■ Removing the Battery:

According to "▼" on the battery release, push the battery lock release tab to remove the battery.

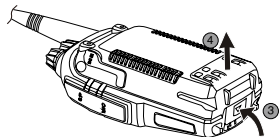

### ((( Installing / Removing the Antenna

#### ■ Installing the Antenna:

Screw the antenna into the connector on the top of the transceiver by holding the antenna at its base and turning it clockwise until secure.

#### ■ Removing the Antenna:

To remove it: Turn the antenna counterclockwise until the antenna has been removed from the threads of the transceiver.

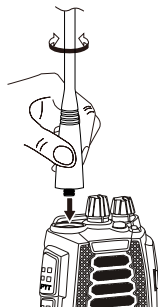

### ((( Installing / Removing the Belt Clip

#### ■ Installing the Belt Clip:

Place the belt clip to the grooves on the back of the transceiver, and then install the screws, turning clockwise.

#### ■ Removing the Belt Clip:

Remove the screws turning counterclockwise, allowing you to remove the belt clip.

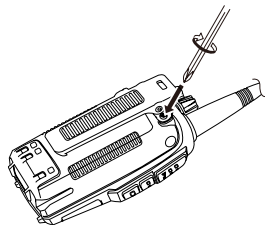

### ((( Installing the Additional Speaker/ Microphone (Optional)

Unveil the MIC-SP jack cover and then insert the Speaker/Microphone plug into MIC-SP jack.

**Note: The transceiver is not completely waterproof while using the Speaker/Microphone.**

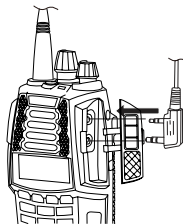



## ◦ GETTING ACQUAINTED

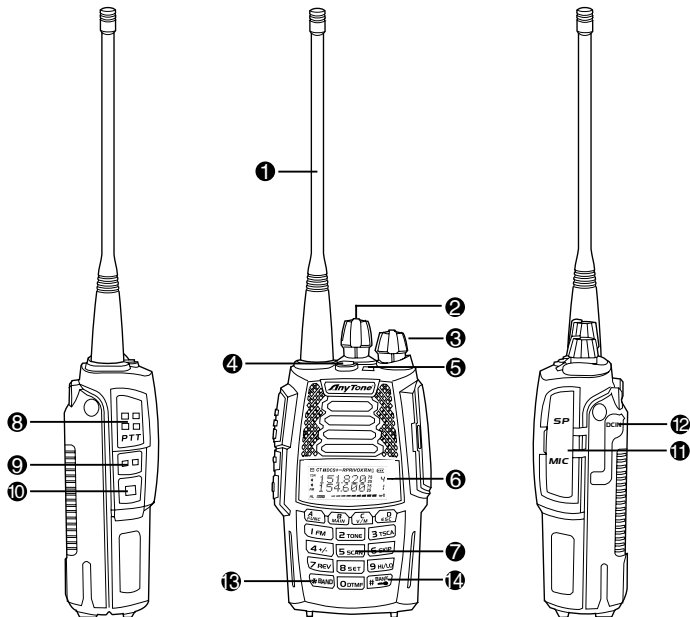

## ◦ GETTING ACQUAINTED

### ❶ Antenna

### ❷ Channel Selector Knob

### ❸ Power / Volume Knob

Rotate it clockwise to turn on the transceiver, rotate it counterclockwise until you hear the "click" to turn off the transceiver.

When the transceiver is powered on, turn the knob clockwise to increase volume, or turn the knob counterclockwise to reduce the volume.

### ❹ Emergency Alarm

Hold 3 seconds to activate the alarm, cycle the radio's power to turn off Alarm.

### ❺ TX/RX indicator, RX is GREEN (Upper Band) or BLUE (Lower Band), TX is RED, Tone Received is PURPLE.

### ❻ LCD display

Displays current frequency/channel and operations

### ❼ Keypad

Enters desired frequency/channel or operations by keypad

### ❽ PTT key

Press PTT key to talk, release this key to receive.

### ❾ PF1 key

### ❿ PF2 key

### ⓫ Speaker/Microphone jack, programming software jack

### ⓬ Car charging port

### ⓭ Single-band Switching

### ⓮ Memory Bank Operation

### ⌂ Turn the Radio On & OFF



When the radio is off turn **[POWER]/ [VOLUME]** clockwise to turn on the transceiver.



When the radio is on, turn **[POWER]/ [VOLUME]** counterclockwise to turn off the transceiver.

### ⌂ Adjusting Volume



When the radio is on, turn **[POWER] / [VOLUME]** to adjust volume. The volume increases when you turn the knob clockwise and decreases when you turn the knob counterclockwise.

**NOTE:** Press the side key programmed as Squelch Off to monitor the background noise. You can turn the **[POWER]/[VOLUME]** knob to control the volume.

**NOTE:INDIVIDUAL CHANNEL SQUELCH LEVEL:** While holding the Key Set as 'SQELCH OFF', turn the [Selector Knob] to adjust squelch level for current channel (this will set the squelch level on the individual channel). Turn [Selector Knob] to adjust squelch level for current channel.

## ◦ BASIC OPERATIONS

### ((( Switch between Channel mode and VFO mode

While in standby, press  key to set the selected band into channel mode or frequency mode(VFO).

**NOTE:**When the transceiver is in channel mode the right side of the frequency will display the channel (or memory bank) number.

### ((( Channel Adjusting

#### 1. Input channel number by scrolling

Rotate the channel switch clockwise to increase the channel number, or rotate it counterclockwise to decrease the channel number. If there is a blank channel between two channels, the radio will automatically skip the blank channel and go onto the next channel.

#### 2. Input channel number by keypad

When the transceiver is in Channel mode the user can input any number to switch to the desired channel. If the channel number entered is an un-programmed channel, the radio will audibly let you know an empty channel has been selected and return to the previously tuned channel.

### ((( Frequency Adjusting

When the transceiver is in VFO frequency mode rotate the channel knob to adjust the frequency, or you can input the frequency by the keypad.

1. Enter the desired frequency by increments.

Rotate the channel knob clockwise to increase the frequency, rotate it counterclockwise to decrease the frequency. The frequency amount changed depends on the chosen frequency step. It will add or reduce the frequency by the chosen step value.

2. Enter the desired frequency by keypad.

**VFO mode:** if you want input frequency 151.820MHz, please press [1], [5], [1], [8], [2], [0] on the keypad.

### ((( Receiving

When your transceiver receives a transmission, the LED light will light up (it will light green if the main band is receiving and will light blue if the sub band is receiving) and the arrow icon will flash, and if the volume is up high enough you will also hear the transmission.

**NOTE: You may not receive the call if your transceiver is set at a high squelch level. If the current channel is programmed with a mandatory decode (RX) tone (CTCSS, DCS, etc), the selected tone also must be present for the call to be heard.**



## ◦ BASIC OPERATIONS

### ((( Transmitting

According to how the [PF1] or the [PF2] key is setup in the programming software, hold the key programmed as Squelch Off to monitor the channel to ensure it is not in use, Then press the [PTT] key and talk into the microphone. Keep the distance between your mouth and the microphone about 1-2 inches. Speak in your normal voice (don't whisper and don't yell into the mic) for the best audio clarity.

**NOTE: When pressing and holding the PTT key, the radio will transmit (and will be indicated by the red LED light). Release the [PTT] key to receive calls.**

### ((( Emergency Alarm

When the transceiver is in standby, press and hold the [ALARM] key until the LCD displays "ALARM". The emergency alarm has now started. This transceiver has 4 Alarm modes. You can set up which mode works best for you in the programming software. Power off the transceiver to exit Alarm.

### ((( Side Key [PF1] Setup and Use

[PF1] key can be customized to suit your needs, the available options are below:

## ◦ BASIC OPERATIONS

1. **VOLT:** Battery capacity inquiry: Under standby, press [PF1] key, LCD displays current battery capacity, press this key again to exit.
2. **CALL:** Transmit the prestored DTMF/5TONE/2TONE/MSK Encode signal in channel.
3. **FHSS (TERMN-8R Only):** Frequency hopping function. Press the [PF1] key to activate the frequency hopping function, The LCD display will "FHSS", and the transceiver will communicate on the frequency in the pre-set hopping frequency range (set by software).

**NOTE: The Receiver and the Sender must have the same hopping frequency, and must setup the MSK decode signaling. Using FHSS may cause interference to sub band receive depending on frequency or setting of Menu 51 (sub-band mute).**

4. **ALARM:** Activated by a long press of the [PF1]/[PF2] key. The LCD will display "**ALARM**" and the transceiver will enable the preset alarm function.
5. **SUBPTT:** Press [PF1]key, transceiver will transmit on the sub-band frequency (use this function to enable "Dual PTT").
6. **MONI:** Depending how you set up the programming software this will activate 'Squelch off' or 'Squelch off Momentary'. Press the [PF1] key, which will open the squelch, you will hear any noise on the frequency. (If you have it set to 'Squelch off' you must press the [PF1]key again to re-enable the squelch - if you have it set to 'Squelch off Momentary' the squelch will only be open as long as you have the [PF1] key pressed).
7. **Transmit tone pulse frequency:** Press and hold [PTT] key, then press [PF1] key to transmit selected tone pulse frequency.

**NOTE: The tone pulse frequency can be set to 1750Hz, 1450Hz, 1000Hz or 2100Hz .**

8. **Clone Mode:** Press and hold the [PF1] key as you turn on the transceiver, to begin and activate the cloning function (see the 'Cloning Cable' Section in this manual for more details)

### ((( Side Key [PF2] Setup and Use





The [PF2] key can be customized to suit your needs, the available options are below:

1. **VOLT:** Battery capacity inquiry: Under standby, press [PF2] key, LCD displays current battery capacity, press this key again to exit.
2. **CALL:** Transmit the prestored DTMF/5TONE/2TONE/MSK Encode signal in channel.
3. **FHSS (TERMN-8R Only):** Frequency hopping function. Press the [PF2] key to activate the frequency hopping function, The LCD display will "FHSS", and the transceiver will communicate on the frequency in the pre-set hopping frequency range (set by software).





**Note :** The Receiver and the Sender must have the same hopping frequency, and must setup the MSK decode signaling. Using FHSS may cause interference to sub band receive depending on frequency or setting of Menu 51 (sub-band mute).

4. **ALARM:** Activated by a long press of the [PF1]/[PF2] key. The LCD will display "**ALARM**" and the transceiver will enable the preset alarm function.
5. **SUBPTT:** Press [PF2] key, transceiver will transmit on the sub-band frequency (use this function to enable "Dual PTT").
6. **MONI:** Depending how you set up the programming software this will activate 'Squelch off' or 'Squelch off Momentary'. Press the [PF2] key, which will open the squelch, you will hear any noise on the frequency. (If you have it set to 'Squelch off' you must press the [PF2] key again to re-enable the squelch - if you have it set to 'Squelch off Momentary' the squelch will only be open as long as you have the [PF2] key pressed).
7. **General Function Setup:** Press and hold the [PF2] key as you turn on the transceiver, to enter the general function setup (see the 'Display Mode Setup' or the 'PART 95' Sections in this manual for more details).

### ((( Add a channel

1. Under frequency mode (VFO), after you have set up your desired frequency and settings (read through the Function Menu Setup in order to understand how to set your desired frequency settings), Press the  key, the top left corner of LCD will display the "✉" icon, then press the  key to enter the manual channel programming mode, the channel number will begin flashing.
2. Rotate the channel knob until the Channel number displays the channel you would like to.
3. Press the  key, the top left corner of LCD displays the "✉" icon, and hold the  key until the transceiver emits the confirmation beep. Your new channel has been programmed successfully.



### ((( Delete a channel





1. While your radio is in standby, Press the  key, the top left corner of LCD will display the "✉" icon, then press the  key to enter the manual channel programming mode, the channel number will begin flashing.
2. Rotate the channel knob until the Channel number displays the channel you would like to remove.
3. Press the  key, the top left corner of LCD displays the "✉" icon, and hold the  key until the transceiver emits a confirmation beep. Your channel has been successfully deleted.

**Note :** This process can be used for FM radio channels as well.

## ◦ SHORTCUT OPERATIONS





### ((( Add/Cancel Optional signal decode function

When in standby, press  key, the top left corner of LCD displays "✉" icon, press  key.

1. The LCD displays "DTMF" and "" icon, DTMF signaling has been added in the current channel.
2. Repeat the above operation, the LCD displays "5TONE" and "" icon, the 5TONE signaling has been added in current channel.
3. Repeat the above operation, the LCD displays "2TONE" and "" icon, the 2TONE signaling has been added in the current channel.
4. (TERMN-8R ONLY) Repeat the above operation, the LCD displays "MSK" and "" icon, MSK signaling has been added in the current channel.
5. Repeat the above operation, the LCD displays "OFF", the "" icon disappears, and no optional signaling has been added in current channel.



**NOTE:** When this function is on, the user must setup the SIGNAL menu to use the TONE option, then DTMF/5TONE/2TONE/MSK can be used (For decoding). The programming software is required to set the tones needed if you require specific optional signaling.

### ((( CTCSS/DCS Scan

Press  key, the top left corner of LCD displays "✉" icon, press  key to enter into CTCSS/DCS scan. Under this state, rotate the channel knob to change the scanning direction. When the scan receives CTCSS/DCS signaling, it will stay 5seconds and then continue scanning. Rotate the channel selector knob to change the scanning direction. When scan the matching CTCSS/DCS signaling, it will stay 5seconds and then continue scanning. Press any other keys except , ,  key to exit.

**NOTE: This function will not work when the transceiver is set up in the professional mode or the current selected channel does not have any CTCSS/DCS signal first set up. If your current channel has its tone signaling set as CTCSS, it will scan CTCSS, if its tone signaling is set as DCS, it will scan DCS.**

### ((( Offset Frequency Direction Setup

When in standby, press  key, the top left corner of LCD displays "✉" icon, press  key to choose offset frequency direction. There are 3 options, Plus offset, Minus offset, remove offset.



1. **(+) Plus offset:** Indicates TX frequency is higher than RX frequency. If the reverse function is enabled, the RX frequency is higher than TX frequency.
2. **(-) Minus offset:** Indicates that the TX frequency is lower than the RX frequency. If the reverse function is enabled, the RX frequency is lower than TX frequency.
3. **None:** Indicates that the offset is off.

Under frequency mode (VFO) or channel mode, press  key then press  key to choose plus offset direction(+), minus offset direction (-), remove offset (Please refer to offset frequency setup).

**NOTE: This function is unavailable in professional transceiver mode.**

## ◦ SHORTCUT OPERATIONS

### ((( Frequency/Channel Scan

Under the corresponding mode, press  key, the top left corner of LCD displays "✉" icon, then press  key to start frequency scan or channel scan.



#### 1. Frequency Scan

Under VFO mode, frequency scanning is available. The frequencies will be scanned by the transceiver's 'step' setup, press any numeric key or  key to exit.

#### 2. Channel Scan

Under channel mode, channel scanning is available. The channels will be scanned in order of the channel setup as long as they are not programmed to "Skip" during scanning, Press numeric key or the  key to exit.



### ((( Channel Scan Skip

Under channel mode, press  key, the top left corner of LCD displays "✉" icon, then press  key to set current selected channel as Channel scan skip. Repeat above operation to cancel channel scan skip.

1. LCD displayed "" means the current channel will not be scanned.

2. "" icon disappeared means the current channel will be scanned.



### ((( Frequency Reverse

When in standby, press  key, the top left corner of LCD displays "✉" icon, then press  key to set arrow directed channel as frequency reverse, repeat above operation to turn off frequency reverse.

## ◦ SHORTCUT OPERATIONS



1. When LCD displays "R" icon, it means current selected channel has the frequency reverse function enabled, the TX frequency and RX frequency are reversed, if CTCSS/DCS signaling is set, they will also interchange.
2. When "R" icon disappears, it means that the channel is normal and is not reversed.

### ((( TX Power selection

When in standby, press  key, the top left corner of LCD displays "✉" icon, then press  key to choose High/Middle/Low power for the current selected channel.

1. When LCD displays "L" icon, it means low power has been chosen.
2. When LCD displays NO icon, it means middle power has been chosen.
3. When LCD displays "H" icon, it means high power has been chosen.



### ((( Talk Around function

When in standby, press  key, the top left corner of LCD displays "✉" icon, then press , the current selected channel will enable talk around, repeat the above operation to close talk around.

1. **TX=RX:** Enable talk around, current channel transmit at RX frequency, if CTCSS/DCS signaling is set, it will interchange decoding CTCSS/DCS as encoding.
2. **OFF:** Close talk around.



### ((( DTMF code Transmit and Enquiry

1. Press  key, the top left corner of LCD displays "✉" icon, then press  key, LCD displays DTMF data and group number (total 16 groups) of current group.



## o SHORTCUT OPERATIONS

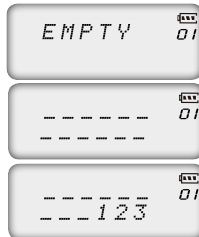

2. Rotate channel selector knob to choose desired group and DTMF data, press [PTT] key to transmit selected DTMF signaling. If the current group has no entered DTMF data, the LCD will display the current group number and **"EMPTY"**.
3. When the current group displays **"EMPTY"**, Press  key, the top left corner of the LCD will display "" icon, then press and hold 0 key until you hear a responsive beep to get the transceiver to enter into the DTMF edit state. The LCD now displays "\_\_\_\_\_", now you can enter desired DTMF data by keypad.
4. When finished editing, press side key [PF2] to save DTMF signaling.



### Keypad lock

Keypad lock operation can be done by software programming or radio keypad.

#### 1) Radio keypad operation

Press  key, the top left corner of LCD displays "✉" icon, then press and hold  key until you hear a responsive beep and the LCD displays "m0" icon. This means the keypad is now locked. Repeat the above procedure and the "m0" icon will disappear. The keypad lock function is now off and the keypad is responsive again.

#### 2) Software Programming

**ON:** Keypad lock option tick on.

**OFF:** Keypad lock option tick off.





**NOTE: When keypad lock is turned on by software programming the keypad lock operation is invalid.**

### ((( Single-band Switching

To avoid interference from the sub channels when the main channel is in use, you can use the single band function to turn off the sub channel band quickly.







Continuous pressing of  will cycle LCD display to show Main + Sub-Band / Sub-Band Only / Main-Band Only.

### ((( CTCSS/DCS Encode and decode

1. Press  key then press [PF2] to enter into setup.
2. Press [PF2] key to choose CTCSS, DCS or OFF, if you choose DCS, press  key to select positive or negative code.
3. Rotate the channel knob to choose your desired CTCSS/DCS encode and decode.
4. Press  key or  key to confirm and exit.

## ◦ SHORTCUT OPERATIONS

### ((( MSK (Text) Signal Sending (TERMN-8R ONLY)

1. When in standby, press  key then press [PF1] key to enter the MSK signal edit function, the LCD will display "\_MSG\_".
2. Turn the channel knob to choose the desired alpha numeric character.
3. Press [PF1] to go to the next character input. Press [PF2] key to go back to the previous character input. You can press the numeric keys to quickly input 0-9, and the next character will automatically be chosen.
4. Once you have chosen your message, press  key, the LCD will display "CAL ID" which will allow you to input the receiver's ID then press  key or [PTT] key to send your message.
5. Alternatively after you have composed your message, press the  key, and the LCD will display "CAL ID" then press  /  key and you can choose: Call All "CAAL" or Group Calling "CAL GR" (which you will need to input the group ID) and then press  key or [PTT] key to send.

**NOTE:**Please refer to the MSK ENCODE/DECODE Setup Options to learn more about the basic setup – found in the ADVANCED FUNCTION OPERATIONS.

### ((( CTCSS/DCS Encode Setup

1. Press key, the top left corner of LCD displays "✉" icon, then press key to enter into function menu.
2. Press / key to choose NO.01 function item, it shows "**T-CDC**" on LCD.
3. Press key to choose CTCSS, DCS or OFF, when DCS signaling is selected, press key to choose DCS positive or inverse code.
4. Rotate channel selector knob to choose desired CTCSS/DCS code.  
**CTCSS:** 62.5HZ-254.1HZ, 51groups in total, and 1 group user-defined code.  
**DCS:** 000N-777I, 1024 groups in total. "N" stands for positive code, "I" stands for inverse code.
5. Press or key to confirm and exit.

**Note:** User-defined CTCSS encode must be setup by programming software.

### ((( CTCSS/DCS Decode Setup

If this function is enabled, you can ignore (can not hear) other unrelated call at the same frequency.

1. Press key, the top left corner of LCD displays "✉" icon, then press key to enter into function menu.
2. Press / key to choose NO. 02 function item, it shows "**R-CDC**" on LCD.
3. Press key to choose CTCSS,DCS or OFF, when DCS signaling is selected, press key to

## ○ FUNCTION MENU SETUP

choose DCS positive or inverse code.

4. Rotate channel selector knob to choose desired CTCSS/DCS code.

**CTCSS:** 62.5HZ~254.1HZ, 51 groups in total, and 1 group user-defined code.

**DCS:** 000N-777I, 1024 groups in total. "N" stands for positive code, "I" stands for inverse code.









5. Press  or  key to confirm and exit.



**Note: User-defined CTCSS decode must be setup by programming software.**

## ((( CTCSS/DCS Encode/Decode Synchronous Setup

This function is for adjusting CTCSS/DCS encode/decode synchronous. (simultaneous changes Menu NO 01 and 02).

1. Press  key, the top left corner of LCD displays "✉" icon, then press  key to enter into function menu.
2. Press  /  key to choose NO. 03 function item, it shows "RT-CDC" on LCD.
3. Press  key to choose CTCSS, DCS or OFF, when DCS signaling is selected, press  key to choose DCS positive or inverse code.
4. Rotate channel selector knob to choose desired CTCSS/DCS encode/decode.  
**CTCSS:** 62.5HZ~254.1HZ, 51 groups in total, and 1 group user-defined code.  
**DCS:** 000N-777I, 1024 groups in total. "N" stands for positive code, "I" stands for inverse code.
5. Press  or  key to confirm and exit.

## ○ FUNCTION MENU SETUP

*AnyTone*  
tech

**Note: User-defined CTCSS decode must be setup by programming software.**



### ((( 5TONE encode group selection

1. Press **A FUNC** key, the top left corner of LCD displays "✉" icon, then press **B SET** key to enter into function menu.
2. Press **B MAIN** / **C V/M** key to choose NO.04(OBLTR-8R)/NO.05(TERMN-8R) function item, it shows "**5T-ENC**" on LCD.
3. Rotate channel selector knob to choose desired 5TONE encode group.  
CALL00~CALL99, 100 groups in total for optional.
4. Press [PTT] key to transmit selected 5TONE encode, press **D ESC** key or **# BANK** key to confirm and exit.







**5TONE encode must be programmed by software, only the groups that have edited 5TONE can be selected. When 5TONE encode has a name, transceiver will display name, otherwise will display "CALL XX".**

### ((( 2TONE encode group selection

1. Press **A FUNC** key, the top left corner of LCD displays "✉" icon, then press **B SET** key to enter into function menu.

## ○ FUNCTION MENU SETUP

2. Press  /  key to choose NO.05(OBLTR-8R)/NO.04(TERMN-8R) function item, it shows "2T-ENC" on LCD.
3. Rotate channel selector knob to choose desired 2TONE encode group.
4. Press [PTT] key to transmit selected 2TONE encode, press  key or  key to confirm and exit.







2T-ENC  
CALL00

**2TONE encode must be programmed by software, only the groups that have edited 2TONE can be selected. When 2TONE encode has a name, transceiver will display name, otherwise will display "CALL XX".**

### ((( Optional signaling setup

DTMF, 2TONE (Paging), 5TONE, MSK (TERMN-8R Only) functions are similar to CTCSS/DCS, it has special call functions, such as ANI, PTT ID, All call, Alarm, remotely kill, remotely stun and remotely waken, etc. (MSK gives the capabilities of Message sending and FHSS - TERMN-8R Only).

1. Press  key, the top left corner of LCD displays "✉" icon, then press  key to enter into function menu.
2. Press  /  key to choose NO.06(OBLTR-8R)/NO.08(TERMN-8R) function item, it shows "TONDEC" on LCD.
3. Rotate channel selector knob to choose desired optional signaling.



TONDEC  
DTMF



TONDEC  
5TONE



TONDEC  
OFF

**DTMF:** Current optional signaling is DTMF.

**5TONE/2TONE/MSK:** Current optional signaling is 5TONE/2TONE/MSK.

**OFF:** Close optional signaling.

4. Press key or key to confirm and exit.

### ((( 2TONE decode group selection

1. Press key, the top left corner of LCD displays " " icon, then press key to enter into function menu.

2. Press / key to choose NO.07(OBLTR-8R)/NO.06(TERMN-8R) function item, it shows "2T-DEC" on LCD.

3. Rotate channel selector knob to choose desired 2TONE decode group. DEC 00~DEC 15, 16 groups in total for optional (programmed by software).

4. Press key or key to confirm and exit.



### ((( MSK encode group selection(TERMN-8R ONLY)

1. Press key, the top left corner of LCD displays " " icon, then press key to enter into function menu.

2. Press / key to choose NO.07 function item, it shows "**MSKENC**" on LCD.

3. Rotate channel selector knob to choose desired MSK encode group.CALL 00~CALL31, 32 groups in total for optional (programmed by software).





4. Press key or key to confirm and exit.



## ○ FUNCTION MENU SETUP

### ((( Squelch mode setup

This function is used for setting squelch mode to prevent receiving unrelated signals.

1. Press  key, the top left corner of LCD displays "✉" icon, then press  key enter into function menu.
2. Press  /  key to choose NO.08(OBLTR-8R)/NO.09(TERMN-8R) function item, it shows "SIGNAL" on LCD.

3. Rotate channel selector knob to choose desired squelch mode.

**SQ:** When current channel receives matching RF signals, transceiver can hear the talking from the other party.

**CT/DCS:** When current channel receives matching RF signals and matching CTCSS/DCS signaling, transceiver can hear the talking from the other party.

**TONE:** When current channel receives matching RF signals and matching optional signaling, transceiver can hear the talking from the other party.

**CT&TO:** When current channel receives matching RF signals+matching optional signaling + matching CTCSS/DCS signaling, transceiver can hear the talking from the other party.

**CT/TO:** When current channel receives matching RF signals, or matching optional signaling, or matching CTCSS/DCS signaling, transceiver can hear the talking from the other party.

4. Press  key or  key to confirm and exit.



### ⌘ Frequency step size setup

1. Press key, the top left corner of LCD displays "✉" icon, then press key enter into function menu.
2. Press / key to choose NO.09(OBLTR-8R)/NO.10(TERMN-8R) function item, it shows "**STEP**" on LCD.
3. Rotate channel selector knob to choose desired step size.  
**Stepping:** 2.5K, 5K, 6.25K, 10K, 12.5K, 20K, 25K, 30K, 50K, 9 options in total.
4. Press key or key to confirm and exit.



**NOTE: This function item will hide automatically when main band and sub main band are under channel mode.**

### ⌘ Wide / Narrow Band Selection

- According to the laws of various countries on frequency spectrum, you can set communication for (25k) wide band or (12.5k) narrow band.
1. Press key, the top left corner of LCD displays "✉" icon, then press key enter into function menu.
  2. Press / key to choose NO.10(OBLTR-8R)/NO.11(TERMN-8R) function item, it shows "**W/N**" on LCD.
  3. Rotate channel selector knob to choose desired setup.  
**25K:** Wide band; **12.5K:** Narrow band.
  4. Press key or key to confirm and exit.



## ○ FUNCTION MENU SETUP

### ((( Frequency Reverse

1. Press **A FUNC** key, the top left corner of LCD displays "✉" icon, then press **B SET** key enter into function menu.
2. Press **B MAIN** / **C V/M** key to choose NO.11(OBLTR-8R)/NO.12(TERMN-8R) function item, it shows "REV" on LCD.
3. Rotate channel selector knob to choose desired setup.

**ON:** Turn on Frequency reverse function, TX and RX frequency of current channel will be interchanged. If CTCSS/DCS signaling is set, it also will be interchanged.

**OFF:** Close Frequency reverse function.

4. Press **D ESC** key or **# BACK** key to confirm and exit.



### ((( Talk Around ON/OFF

When this function is is turned on, the transceiver will stop communication with a repeater (it will remove the Offset).

1. Press **A FUNC** key, the top left corner of LCD displays "✉" icon, then press **B SET** key enter into function menu.
2. Press **B MAIN** / **C V/M** key to choose NO.12(OBLTR-8R)/NO.13(TERMN-8R) function item, it shows "TALKAR" on LCD.
3. Rotate channel selector knob to choose desired setup.

**TX=RX:** Turn on Talk Around function, current channel will transmit at RX frequency, if CTCSS/DCS signaling is set, it will interchange decoding CTCSS/DCS as encoding.



**OFF:** Close Talk Around function.

4. Press **[D ESC]** key or **[# BANK]** key to confirm and exit.

### Offset Frequency setup

This function will allow your radio to communicate through a repeater. When the repeater receives signals at one frequency, it will transmit them on another frequency. The difference between these two frequencies is called the offset frequency.

1. Press **[A FUNC]** key, the top left corner of LCD displays "✉" icon, then press **[8 SET]** key enter into function menu.
2. Press **[B MAIN] / [C V/M]** key to choose NO.13(OBLTR-8R)/NO.14(TERMN-8R) function item, it shows "OFFSET" on LCD.
3. Rotate channel selector knob to choose desired offset frequency.  
Frequency range is 00-70MHz.
4. Press **[D ESC]** key or **[# BANK]** key to confirm and exit.

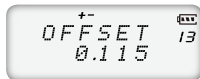

### Editing Channel name





1. Press **[A FUNC]** key, the top left corner of LCD displays "✉" icon, then press **[8 SET]** key enter into function menu.
2. Press **[B MAIN] / [C V/M]** key to choose NO.14(OBLTR-8R)/NO.15(TERMN-8R) function item, it shows "-" on LCD.
3. Rotate channel selector knob to choose desired character, press **[I FM]** key to confirm current character and move shift to next character. Press **[4 +/-]** key back to the previous character.
4. Press **[D ESC]** key or **[# BANK]** key to confirm and exit.



## ○ FUNCTION MENU SETUP

### ((( Busy Channel Lockout

BCLO function is used to prohibit transmitting on a busy channel, it can prevent disturbing other transceivers operating on the same frequency. If you press PTT, the radio will beep as warning and go back to a receiving state.

1. Press  key, the top left corner of LCD displays "✉" icon, then press  key enter into function menu.
2. Press  /  key to choose NO.15(OBLTR-8R)/NO.16(TERMN-8R) function item, it shows "RPLOCK" on LCD.
3. Rotate channel selector knob to choose desired setup.

**BUSY:** Carrier wave lock, transmitting is prohibited when received matching frequency and tone wave.

**REPEAT:** Signal lock, transmitting is prohibited when received matching carrier (frequency) (CTCSS and DCS tones are ignored in this setting).

**OFF:** No BCLO function.

4. Press  key or  key to confirm and exit.



RPLOCK 15  
BUSY



RPLOCK 15  
REPEAT



RPLOCK 15  
OFF

### ((( TX OFF



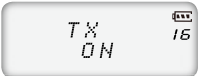



When this function is on, the [PTT] key is not allowed on the current channel. Current channel of transceiver only works as a receiver and not a transmitter.



TX 15  
ON

## ○ FUNCTION MENU SETUP

*AnyTone*  
tech

1. Press  key, the top left corner of LCD displays "☑" icon, then press  key enter into function menu.
2. Press  /  key to choose NO.16(OBLTR-8R)/NO.17(TERMN-8R) function item, it shows "TX" on LCD.
3. Rotate channel selector knob to choose desired setup.  
**ON:** TX OFF is enabled.  
**OFF:** TX OFF is disabled.
4. Press  key or  key to confirm and exit.



## ○ FUNCTION MENU SETUP

### ⌘ Sub Band Display Setup

1. Press **A FUNC** key, the top left corner of LCD displays "✉" icon, then press **B SET** key enter into function menu.
2. Press **B MAIN** / **C V/M** key to choose NO.18(OBLTR-8R)/NO.33(TERMN-8R) function item, it shows "DPSUB" on LCD.
3. Rotate channel selector knob to choose desired setup.  
**FREQ:** Display sub band frequency or channel.  
**VOLT:** Display current battery voltage.  
**OFF:** Sub band display is disabled.
4. Press **D ESC** key or **# BANK** key to confirm and exit.



### ⌘ Keypad Voice Prompt Setup

1. Press **A FUNC** key, the top left corner of LCD displays "✉" icon, then press **B SET** key enter into function menu.
2. Press **B MAIN** / **C V/M** key to choose NO.19(OBLTR-8R)/NO.34(TERMN-8R) function item, it shows "BEEP" on LCD.
3. Rotate channel selector knob to choose desired setup.  
**ON:** Keypad Beep Prompt is enabled.  
**OFF:** Keypad Beep Prompt is disabled.
4. Press **D ESC** key or **# BANK** key to confirm and exit.



### ⌘ Time-Out-Timer (TOT)

The purpose of Time-out-Timer is to restrict the transceiver from accidental long-term transmissions. If the transmission time goes beyond the preset time limit, the transceiver is forced to stop transmitting and warn the user and make a beep sound.

1. Press **[A FUNC]** key, the top left corner of LCD displays "✉" icon, then press **[B SET]** key enter into function menu.
2. Press **[B MAIN] / [C V/M]** key to choose NO.20(OBLTR-8R)/NO.35(TERMN-8R) function item, it shows "TOT" on LCD.
3. Rotate channel selector knob to choose desired setup.  
OBLTR-8R: 1~27 minutes, total 27minutes of TOT for optional, each interval is 1minute.  
TERMN-8R:10-270S,total 27 levels for options each level step 10seconds.
4. Press **[D ESC]** key or **[# BANK 20]** key to confirm and exit.



### ⌘ Voice Operated Transmission (VOX) Setup

When this function is enabled, the transmitting can be started by your voice (generally used with an earpiece), When it is enabled there is no need to press the [PTT] key.

1. Press **[A FUNC]** key, the top left corner of LCD displays "✉" icon, then press **[B SET]** key enter into function menu.
2. Press **[B MAIN] / [C V/M]** key to choose NO.21(OBLTR-8R)/NO.36(TERMN-8R) function item, it shows "VOX" on LCD.
3. Rotate channel selector knob to choose desired setup.





## ○ FUNCTION MENU SETUP(VERSION D)

**1~10:** Total 10 VOX levels for optional.



**OFF:** VOX function is disabled.



4. Press  key or  key to confirm and exit.

### ((( VOX Delay Setup

In order to prevent the transceiver from returning back to the receive mode during a VOX initiated call, (which may cause some of the transmission to be missed) the user can set a suitable delay time before the VOX transmission is ended.



1. Press  key, the top left corner of LCD displays "✉" icon, then press  key enter into function menu.

2. Press  /  key to choose NO.22(OBLTR-8R)/NO.37(TERMN-8R) function item, it shows "VDELAY" on LCD.

3. Rotate channel selector knob to choose desired setup.



**0.5S-3S:** Total 27 levels for optional, each interval is 0.1S

4. Press  key or  key to confirm and exit.

### ((( Automatic Power Off Time setup

When this function is on, transceiver will automatic power off when reach the preset time.

1. Press  key, the top left corner of LCD displays "✉" icon, then press  key enter into function menu.

2. Press  /  key to choose NO.23(OBLTR-8R)/NO.38(TERMN-8R) function item, it shows "APO" on LCD.

## ○ FUNCTION MENU SETUP

*AnyTone*  
tech

3. Rotate channel selector knob to choose desired setup.





30minutes ~ 2hours: Total 3 levels for optional.

**OFF:** Automatic Power Off Time is disabled.

4. Press  key or  key to confirm and exit.



## (((DTMF Transmitting Time Setup

1. Press  key, the top left corner of LCD displays "✉" icon, then press  key enter into function menu.
2. Press  /  key to choose NO.24(OBLTR-8R)/NO.39(TERMN-8R) function item, it shows "DTMF" on LCD.
3. Rotate channel selector knob to choose desired setup.

**50MS:** Each DTMF signal transmits 50ms, interval 50ms.

**100MS:** Each DTMF signal transmits 100ms, interval 100ms.

**200MS:** Each DTMF signal transmits 200ms, interval 200ms.

**300MS:** Each DTMF signal transmits 300ms, interval 300ms.

**500MS:** Each DTMF signal transmits 500ms, interval 500ms.

4. Press  key or  key to confirm and exit.



## (((Squelch level setup

This function is used to setup open the squelch of receiving signals, the transceiver will only allow calls

## ○ FUNCTION MENU SETUP

**NOTE: Individual Squelch levels per channel can be set if you have a PF1/PF2 key programmed as Squelch off. While the Squelch is off – turn the channel selector knob which will allow a Per-Channel Squelch change.**

when the receiving signal strength hits a minimum strength clarity, otherwise, the transceiver will remain muted.

1. Press **A FUNC** key, the top left corner of LCD displays "✉" icon, then press **B SET** key enter into function menu.
2. Press **B MAIN** / **C V/M** key to choose NO.25(OBLTR-8R)/NO.40(TERMN-8R) function item, it shows "SQL" on LCD.
3. Rotate channel selector knob to choose desired setup.  
**00~09**: 10 levels of squelch in total for optional, "00" is minimum setup value (normally open).
4. Press **D ESC** key or **# BANK** key to confirm and exit.



## ((( **Scanning Resume Time Setup**

There are four kinds of scanning dwell time.

1. Press **A FUNC** key, the top left corner of LCD displays "✉" icon, then press **B SET** key enter into function menu.
2. Press **B MAIN** / **C V/M** key to choose NO.26(OBLTR-8R)/NO.41(TERMN-8R) function item, it shows "SCAN" on LCD.
3. Rotate channel selector knob to choose desired setup.



**5ST:** When scanning matched signal, transceiver will stop scanning for 5seconds then resume.

**10ST:** When scanning matched signal, transceiver will stop scanning for 10seconds then resume.

**15ST:** When scanning matched signal, transceiver will stop scanning for 15seconds then resume.

**2SP:** When scanning matched signal, transceiver will stop scanning, 2seconds after signal disappears, scanning will resume.

4. Press key or key to confirm and exit.

### ((( Scan Speed

1. Press key, the top left corner of LCD displays " " icon, then press key enter into function menu.



2. Press / key to choose NO.27(OBLTR-8R)/NO.42(TERMN-8R) function item, it shows "SPEED" on LCD.



3. Rotate channel selector knob to choose desired setup.

**QUICK:** Fast scan speed.





**NORMAL:** Normal scan speed.

4. Press key or key to confirm and exit.

**NOTE:** Fast scan speed may not stop on all signals present. Some weak signals may be skipped.

## FUNCTION MENU SETUP

### Function Icon Stay Time Setup

1. Press  key, the top left corner of LCD displays "  " icon, then press  key enter into function menu.
2. Press  /  key to choose NO.28(OBLTR-8R)/NO.43(TERMN-8R) function item, it shows "FTIME" on LCD.
3. Rotate channel switch to choose desired setup.

**FUNCT:** After you finish your function setting or enter into function menu, the icon will disappear

**1SEC:** After you finish your function setting or enter into function menu, the icon stay on the display for 1 second and then will disappear.

**2SEC:** After you finish your function setting or enter into function menu, the icon stay on the display for 2 seconds and then will disappear.

**3SEC:** After you finish your function setting or enter into function menu, the icon stay on the display for 3 seconds and then will disappear.

**ALWAYS:** The function icon will always display, only when you press the function key again, will the icon will disappear.

4. Press  key or  key to confirm and exit.

**NOTE:** When the function icon is set to stay, the user can set the desired functions continuously, without a need to press the function key every time.



### LCD Backlight Setup

1. Press **A FUNC** key, the top left corner of LCD displays "✉" icon, then press **8 SET** key enter into function menu.
2. Press **B MAIN** / **C V/M** key to choose NO.29(OBLTR-8R)/NO.44(TERMN-8R) function item, it shows "**LIGHT**" on LCD.
3. Rotate channel selector knob to choose desired setup.  
**AUTO**: Backlight will automatic turn off after a period.  
**OFF**: Always off.  
**ON**: Always on.
4. Press **D ESC** key or **# BANK** key to confirm and exit.



### LCD Backlight Color Setup

There are three backlight colors that you can choose from to be the default color.

1. Press **A FUNC** key, the top left corner of LCD displays "✉" icon, then press **8 SET** key enter into function menu.
2. Press **B MAIN** / **C V/M** key to choose NO.30(OBLTR-8R)/NO.45(TERMN-8R) function item, it shows "**COLOR**" on LCD.
3. Rotate channel selector knob to choose desired setup.  
**BLUE**: Blue backlight.  
**ORG**: Orange backlight.  
**PUR**: Purple backlight.
4. Press **D ESC** key or **# BANK** key to confirm and exit.



## ○ FUNCTION MENU SETUP

### ((( Self ID inquiry

1. Press **A FUNC** key, the top left corner of LCD displays "✉" icon, then press **B SET** key enter into function menu.
2. Press **B MAIN** / **C V/M** key to choose NO.31(OBLTR-8R)/NO.46(TERMN-8R) function item, it shows "ID" on LCD.
3. Rotate channel selector knob to choose desired setup.  
The ID code displaying on LCD is transceiver self ID code.
4. Press **D ESC** key or **# BANK** key to confirm and exit.



**NOTE: When current channel add 5TONE to be optional signaling, LCD displays 5TONE self ID code, otherwise displays DTMF self ID code.**

### ((( Tone Pulse Frequency Selection

This function is used for waking up a repeater that requires a tone burst. You will need to know if your repeater requires a tone burst and the tone required. In general, as long as the repeater has been activated, there is no need to transmit the Tone Pulse again until a preset time has expired.

1. Press **A FUNC** key, the top left corner of LCD displays "✉" icon, then press **B SET** key enter into function menu.
2. Press **B MAIN** / **C V/M** key to choose NO.32(OBLTR-8R)/NO.47(TERMN-8R) function item, it shows "TBST" on LCD.
3. Rotate channel selector knob to choose desired setup.  
1750HZ, 2100HZ, 1450HZ, 1000HZ - These are the 4 settings you can set as required by your local repeater.
4. Press **D ESC** key or **# BANK** key to confirm and exit.



## ((( Battery Save Setup

You can set a battery save ratio according to your requirements. The standby time can be extended if you enable the battery save function, but if you set the ratio setting too high, it may cause you to miss the beginning of a transmission. When the transceiver receives a matching signal or make start an operation it will automatically exit this function.

1. Press **A** **FUNC** key, the top left corner of LCD displays "✉" icon, then press **8** **SET** key enter into function menu.



2. Press **B** **MAIN** / **C** **V/M** key to choose NO.33(OBLTR-8R)/NO.48(TERMN-8R) function item, it shows "SAVE" on LCD.



3. Rotate channel selector knob to choose desired setup.

**OFF:** Battery Save is disabled.

**1:2:** The standby time between normal working state and battery saving mode is 1:2

**1:3:** The standby time between normal working state and battery saving mode is 1:3

**1:5:** The standby time between normal working state and battery saving mode is 1:5

**1:8:** The standby time between normal working state and battery saving mode is 1:8

**AUTO:** Battery save ratio is adjusting automatically.



4. Press **D** **ESC** key or **#** **BANK** key to confirm and exit.



## FUNCTION MENU SETUP

### PF1 key Function Setup

1. Press **A** FUNC, the top left corner of LCD display "  " icon, then press **B** SET key to enter into function menu.
2. Press **B** MAIN / **C** V/M key to choose NO.47(OBLTR-8R)/NO.30(TERMN-8R) function item, it shows "PF1" on LCD.
3. Turn channel switch to choose desired setup.
  - VOLT**: Display current battery voltage.
  - CALL**: Calling.
  - FHSS**: Frequency hopping
  - ALARM**: Emergency alarm.
  - SUBPTT**: Sub band PTT
  - MONI**: Squelch off Momentary or Squelch off function
  - OFF**: Close the key function.
4. Press **D** ESC or **#** BANK to confirm and exit.



## Ⓜ PF2 key Function Setup



1. Press **A FUNC**, the top left corner of LCD display "✉" icon, then press **B SET** key to enter into function menu.
2. Press **B MAIN** / **C V/M** key to choose NO.48(OBLTR-8R)/NO.31(TERMN-8R) function item, it shows "PF2" on LCD.
3. Turn channel selector knob to choose desired setup.  
**VOLT:** Display current battery voltage.  
**CALL:** Calling  
**FHSS:** Frequency hopping  
**ALARM:** Emergency alarm.  
**SUBPTT:** Sub band PTT  
**MONI:** Squelch off Momentary or Squelch off function  
**OFF:** Close the key function.
4. Press **D ESC** or **# BANK** to confirm and exit.



## ◦ ADVANCED FUNCTION OPERATIONS

### ((( Display Mode Setup

There are three kinds of display (user) modes.

1. Press [PF2] key as you turn on the radio, continue holding the [PF2] key until the transceiver emits a beep.
2. Press  /  key to choose No.01 function item, it shows "DSP" on LCD.
3. Rotate channel switch to choose desired setup.

**FREQ:** Frequency+Channel mode, transceiver displays current channel number + frequency, press  key to switch into VFO mode.

**CH:** Channel mode (for commercial use), 1~24 items of function menu will be disabled, the user can only operate some functions. The VFO Mode is disabled. With this mode, radio can be used as commercial radio.

**NAME:** Channel+Name Tag mode, transceiver displays current channel number +channel name, press  key to switch into VFO mode.

4. Press  key or  key to confirm and exit.







### ((( Resume Factory Default

You can make all the settings of transceiver return back to the factory default settings when the transceiver does not work normally (possible due to bad settings)

## ADVANCED FUNCTION OPERATIONS

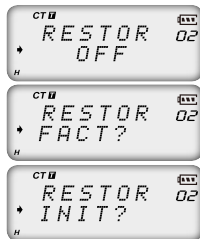

AnyTone<sup>®</sup>  
tech

1. Press [PF2] key to turn on radio, hold [PF2] key until transceiver emits beep.
2. Press  /  key to choose No.02 function item, it shows "RESTOR" on LCD.
3. Rotate channel switch to choose desired setup.  
**OFF:** No operations.  
**FACT:** Resume all items to factory default, including channel and background settings.  
**INIT:** Resume background settings to factory default, channel operations are keeping.
4. Press  key to exit current selection.
5. Press  key to confirm current selection.



## Public Usage Frequency Mode (FCC Part 95)



There are three kinds of modes for optional. NORMAL, and MURS.

1. Press [PF2] key as you turn on the radio, continue holding the [PF2] key until the transceiver emits a beep.
2. Press  /  key to choose No.03 function items, it shows "PART95" on LCD.
3. Rotate channel switch to choose desired setup

**NORMAL:** Normal channel mode

## o ADVANCED FUNCTION OPERATIONS

**MURS:**Multi-Use Radio Service . The Multi-Use Radio Service (MURS) uses channels in the 151 – 154 MHz spectrum range. The most common use of MURS channels is for short-distance, two-way communications using small, portable hand-held radios that function similar to walkie-talkies.

4. Press  or  key to confirm current selection.

### Optional Signaling (DTMF)

Users can enable or disable the "Optional Signaling" in each channel by programming software. DTMF tones are similar to CTCSS/DCS tones and can be used in conjunction with them. You can set the squelch level to require DTMF and/or CTCSS/DCS. DTMF tones can also allow for Selective Calling, Group Calling, All Call, PTT ID, Remotely Stun, Remote Kill and Remote Waking.

1. PTT ID (ANI): If you set your current channel to transmit your PTT ID, the transceiver will send its transmitting ID by pressing or releasing the PTT key according to how you set it up.
2. If you decide to assign radios to groups with DTMF tones - You can set a group call "wildcard" for each group by programming software. (DTMF character A, B, C, D, "\*" or "#").
  - a. The caller can call different groups by sending different group call codes. When the receiving party receives a valid ID code, wildcard characters can replace one or all of the characters and the receiving party can: call all, group call, or selectively call. It is easy and flexible to utilize DTMF tones.

**For example:**

**Group code: "C"**

## ◦ ADVANCED FUNCTION OPERATIONS

	Radio A	Radio B	Radio C	Radio D
ID Code	123	223	235	355

If the calling party uses "C23" to call, Radio A and Radio B will receive the call.

If the calling party uses "CC5" to call, Radio C and Radio D will receive the call.

If the calling party uses "CCC" to call, All Radios will receive the call.

3. This transceiver is set with 16 groups of DTMF codes (you can individually set what the programmed "CALL" (PF1/PF2) does for each channel)
4. Remote Stun, Remote Kill and Remote Wake.
  - a. Remote Stun: When the radio receives the DTMF that will "Remote Stun" it - it can no longer transmit and will receive only.
  - b. Remote Kill: When the radio receives the DTMF that will "Remote Kill" it - it can no longer transmit or receive.
  - c. Remote Wake: The only way to bring a radio out of 'Remote Kill' or 'Remote Stun' is by special dealer programming software --- or you can wake it by sending the 'Remote Wake' DTMF tone. The 'Remote Wake' DTMF tone is activated by: sending the original DTMF 'Kill/Stun' Code + the '#' Tone.

**NOTE: Radios must be set up to 'Decode' optional signaling (DTMF), otherwise they will ignore the DTMF tones being received.**

## ◦ ADVANCED FUNCTION OPERATIONS

### ((( **2TONE Calling**

Two-tone sequential, also known as 1+1, is a selective calling method (2 Tones received to set off the pager function). Many companies have their own names for two-tone sequential options. General Electric Mobile Radio® called it Type 99. Motorola® called it Quik-Call II. For example, the encoder sends a single tone followed by 50 to 1,000 milliseconds of silence and then a second tone.[3] Decoders look for a valid first tone followed by a valid second tone. If no valid second tone is decoded within 2 seconds, the decoder resets and waits for another valid first tone.

To set up the 2TONE needed to encode (send) or decode (receive) you need to set it up through programming software. You can set up to 32 Encode options and 16 Decode.

**NOTE: To set your radio to open for calls only after receiving a 2TONE sequence – set up the channel decode option as needed – and then apply it to the frequency needed. YOU WILL NEED TO SET THE SQUELCH MODE AS "OPTIONAL SIGNALING" to receive the call. Refer to "Function Menu Setup – Squelch mode setup" for more details.**

**NOTE: Radios must be set up to 'Decode' optional signaling (2TONE), otherwise they will ignore the 2TONE tones being received.**

### (((Optional signal (5TONE)

Users can set the "Optional Signaling" as 5Tone in each channel by programming software. 5Tone has similar functions to CTCSS/DCS and DTMF, it allows for Selective Calling, Group Calling, All Call, PTT ID, Remote Stun, Remote Kill, Data Transmission (Text), Alarm, ANI etc.

First setup your radios encode (sending) and decoding (receiving) options on your radio via programming software

1. Selective Calling: Call the receiver's self ID directly – If you set up an encode memory to call another user directly (their 5 Digit PTTID encode) you can Access the 5TONE encode menu (NO.04(OBLTR-8R)/NO.05(TERMN-8R)) to choose your saved signaling (Memory Group) then press PTT key. Receiver can hear the calling after receive matching ID. (According to how they have their Squelch setup (see Squelch options))
2. Group Calling/ All Call: Call by Group or Call All ID – To Group Call (or Call All) you need to use a Wild Card Character: A – to repeat Characters (In this case the wild card character) you use the Repeat Character: E.  
Replace one of the 5 Digits of the Encode setup with the Wild Card Character (A) to call by group. after the receiver receive 5Tone encode. If you set up an encode memory to call by group/all (their 5 Digit PTTID encode) you can Access the 5TONE encode menu (NO.04(OBLTR-8R)/NO.05(TERMN-8R)) to choose your saved signaling (Memory Group) then press PTT key. Receiver/s can hear the calling after receive matching ID. (According to how they have their Squelch setup (see Squelch options))

#### **Example:**



## ◦ ADVANCED FUNCTION OPERATIONS

	Radio A	Radio B	Radio C	Radio D	Radio E
ID Code	78125	79225	68125	69225	65125

If the calling party uses "A8125" to call, Radio A and Radio C will receive the call.

If the calling party uses "AE125" to call, Radio A, Radio C and Radio E will receive the call.

If the calling party uses "7AE25" to call, Radio A and Radio B will receive the call.

If the calling party uses "6AEA5" to call, Radio C, Radio D and Radio E will receive the call.

If the calling party uses "AEAEA" to call, All Radios will receive the call.

**NOTE: You can also set up a custom group not dependent on the user's ANI/Self ID. Under the Information ID section – set up a Decode option for your Group's 5TONE decode. (Example: 12345, 45676543, etc...)**

3. This transceiver can set desired PTT ID by programming software, when you press Call using 5TONE the channel set PTT ID, the transceiver will transmitting ID by pressing or releasing the PTT key (it will default to your selected "SELF ID"). You can also initiate a "Special Call" PTTID which (depending on the receiver's squelch set up) will only display your ID on the receivers display without opening the squelch.
4. Remote Stun, Remote Kill and Remote Wake (this is found in your 5TONE Decode (Receive) Options via programming software)
  - a. Remote Stun: When the radio receives the 5TONE that will "Remote Stun" it - it can no longer transmit and will receive only.
  - b. Remote Kill: When the radio receives the 5TONE that will "Remote Kill" it - it can no longer transmit or receive.

## ◦ ADVANCED FUNCTION OPERATIONS

- c. Remote Wake: Set the 5TONE wake code by programming software, the only way to bring a radio out of 'Remote Kill' or 'Remote Stun' is by receiving the 5TONE wake code.
- 5. Data transmission: You can setup 5TONE Messages to be sent by your 5TONE Encode Function. You need to pre-set up the receiver (by ID or Group) and the message to be sent – so you can access it from 5TONE encode menu (NO.04(OBLTR-8R)/NO.05(TERMN-8R)).
- 6. Emergency alarm: It will turn on alarm function after transceiver receive matching encode
- 7. ANI: It is show the other party's ID if your transceiver receive ANI call. It will also display the caller's name when you have the caller's name set up in programming software.
  - a. To set up a contact list find it under "Communication Note" – and set the values for the ID and corresponding name. It will show the other party's name when they use ANI or Special Call PTTID. Example: You could set up "35356" as "Andy".
- 8. The transceiver can program and save 100 groups of 5Tone encode,.

**NOTE: When you use 5Tone, the receiver and sender must use same encode method. (Selectable by software)  
Such as: The sender use ZVE11, the receiver must use ZVE11.**

**NOTE: Radios must be set up to 'Decode' optional signaling (5TONE), otherwise they will ignore the 5TONE tones being received. The 5TONE self ID has to be 5 digits and you should avoid repeating 'characters' when setting your self ID. If you do repeat characters, the repeated character will be replaced by "E". Example: If your ID is '21125' – it will actually be '21E25'.**

## ◦ ADVANCED FUNCTION OPERATIONS

### ((( Communication Note (Caller ID/PTTID List) (ANI)

Use the programming software to setup a database of Names and PTTIDs. When a PTTID /ANI is received and matches a name in your contact list – it will display the coordinating alpha numeric “Name” instead of the ANI/PTTID.

### ((( MSK ENCODE / DECODE and FHSS-Frequency Hopping (TERMN-8R ONLY)

1. Program PF1/PF2 to operate the FHSS Function
2. From your programming software or the radio insure that you set your optional signaling as MSK (and choose the MSK decode needed for your channel)
3. From the Programming Software - Program your Encode and Decode Information.

**NOTE: DECODE TIPS:** Each radio should have a different Self ID. You can also set up groups IDs (which should be the same on radios that are in the same 'group')

**NOTE: ENCODE TIPS:** You can set your encode groups to call by: ALL, Group (Set it to call the Group ID needed), Individual (Set it to call the Individual PTT ID Needed). The Information Code will tell others who you are (a name or call sign is common). The Name field is so you can set a Name for the New MSK Call you just set up.

**NOTE:** When you set an encode memory for your radio – you can also set a message default in the "information field" to send to the selected receivers. You can send the preset "encode" functions from the Function Menu (refer to Function Menu – MSK)

## ◦ ADVANCED FUNCTION OPERATIONS



4. Set up your frequency hopping. When you set a frequency it will have a frequency within 1 Mhz of the base frequency. (Insure it is the same frequency on the radios you want to communicate on via FHSS).
5. Ensure that the Encode and Decode information you want is correct and double check the decode MSK group you set up.
6. You can now activate FHSS by the PF1/PF2 button you have set up and securely communicate on a randomized frequency with your party.

**NOTE: Radios must be set up to 'Decode' optional signaling (MSK), otherwise they will ignore the MSK tones being received.**

## ◦ ADVANCED FUNCTION OPERATIONS

### ((( Cloning Cable

This feature will copy the programmed data and parameters from the master unit to slave units. It copies the parameters and memory program settings.

Connection: Use optional CP04 cloning cable, connect Read/write frequency port on both master and slave, setting and programing as the requirement below.

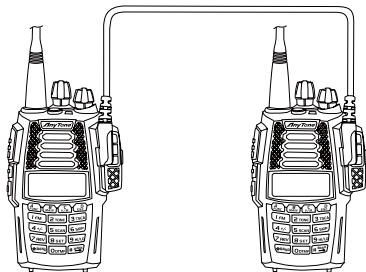

[Settings: Master side]

1. Press the [PF1] side key to Power on, the display shows "CLONE", the master unit enters into copy mode .
2. Press [PF1] key, the display appears "CLONE XX" XX stands for the data amount being cloned.
3. When the data transfer is completed, slave unit restarts, the master unit displays "CLONE 04".
4. Master unit will remain in the cloning mode to prepare for the next cloning session, if you reboot the master radio - it will exit the cloning mode and return back to the normal mode.

CLONE

CLONE  
A5

CLONE  
04

## ◦ ADVANCED FUNCTION OPERATIONS

[Settings: Slave side]

1. In the standby mode, when the slave receives the data, the display shows "CLONE XX" XX stands for the data being cloned.
2. When data reception is complete, the slave unit returns to normal mode and restarts automatically.
3. Turn off the slave's power, remove the cable, insert another slave that you want to copy.



CLONE  
A5

If the data is not successfully transmitted, turn off the master and slave, check if the cable connections are correct, and then repeat the whole process again.

## ○ Programming software starting (Takes Windows XP system for example)

**AnyTone**  
We only do best radio!

1. Double Click "OBLTR-8R/TERMN-8R.exe", then follow through with the installation.
2. Please plug the programming cable into the USB port of the PC device, then connect to transceiver. (A Genuine FTDI cable from *AnyTone* tech is recommended)
3. Double click "OBLTR-8R/TERMN-8R" shortcut icon, or click OBLTR-8R/TERMN-8R item in "START" menu to open programming software interface.
4. Choose your "COM Port", then click "OK" to start programming software. (the COM Port number can be found under device manager, it will display by the cable driver).

**NOTE: When moving the programming cable to a different USB port, the COM port assignment will change.**

Before programming, insure that your transceiver is powered on. Do not turn on or turn off the transceiver when it is connecting with computer, otherwise it may cause the transceiver not to properly read or write data. If this situation has happened, please shut down the programming software, remove programming cable from the computer. Then re-plug the cable into the computer, re-start the programming software, re-choose the COM Port, and the programming should work normally.

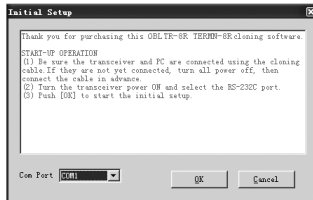

(picture 1)

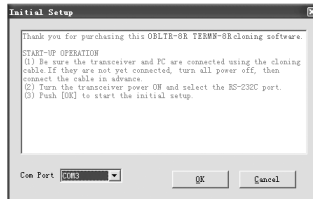

(picture 2)

**NOTE: The programming software has an automatic product identifying system. In order to run it for the first time, the transceiver should be connected to computer, otherwise the software can not run.**

## TECHNICAL SPECIFICATION

General		
Frequency Range	Band A & B	RX: 151.8200~154.6000MHz
		TX: 151.8200~154.6000MHz
Number of channels		Max. 200
Channel Stepping		Wide : 25kHz, Narrow : 12.5kHz
Operating Voltage		7.4 V DC $\pm$ 20%
Battery Life		More than 18 hours at 5 watts (5-5-90 duty cycle with 2200mAh Li battery)
Operating Temperature range		<20= ( to >□□€
Frequency Stability		$\pm$ 2.5ppm
Dimensions and Weight		
With QB-35L (2200mAh Li-ion battery)		66W x 123H x 39D mm 265g



## TECHNICAL SPECIFICATION

<b>Receiver</b> (Measurements made per TIA/EIA-603)	
RF Input Impedance	50Ω
Sensitivity	
EIA 12dB SINAD	Wide : 0.2μV      Narrow : 0.25μV
Selectivity .	Wide : 65dB      Narrow : 60dB
Intermodulation	Wide : 60dB      Narrow : 55dB
Spurious response	65dB
Audio Power Output	500mW at 16Ω less than 10% distortion
<b>Transmitter</b> (Measurements made per TIA/EIA-603)	
RF Output Impedance	50Ω
RF Power Output	2W MURS
Spurious and Harmonics	60dB
FM Noise	Wide : 45dB      Narrow : 40dB
Audio Distortion	Less than 5%

## ◦ TECHNICAL SPECIFICATION

<b>MURS FREQUENCY CHART (MHz)</b>		
<b>CH. No</b>	<b>CH. Freq.</b>	<b>CH. Name</b>
<b>MURS1</b>	151.8200	
<b>MURS2</b>	151.8800	
<b>MURS3</b>	151.9400	
<b>MURS4</b>	154.5700	Blue Dot
<b>MURS5</b>	154.6000	Green Dot

## ◦ TROUBLE SHOOTING GUIDE

<b>Problem</b>	<b>Corrective Action</b>
No power	A.The battery may be depleted. Recharge or replace the battery. B.The battery may not be installed correctly. Remove the battery and install it again. C.The power switch is broken; Contact local dealer for repair. D.Battery tabs or the connection is broken; Contact local dealer for repair.
Battery power dies shortly after charging.	The battery life is finished. Replace the battery pack with a new one.
Transceiver cannot scan	The channels are not in scan list.
All bands pick up static and are noisy	Adjust the squelch settings during programming. Non-professionals are advised not to adjust this function.
No sound after removing earphone	Contact local dealer for repair.
Communication distance becomes short, and Low sensitivity	A.Check whether the antenna is making good contact and the antenna base and has not come loose. B. Antenna connector is broken. (this can happen if you carry the radio by the antenna) (Contact local dealer for repair)
Cannot talk or hear other members in your group	A.Different frequency or channel, please change it. B.Different CTCSS / DCS /DTMF, please reset it. C.Out of communication range.

## ◦ TROUBLE SHOOTING GUIDE

Can not power on or frequent power off	Check if the battery is making good contact and is locked in place.
The transmitting audio gets low or intermittent	Check if the MIC hole is plugged. If you cannot diagnose the issue –contact local dealer for repair.
Receiving is intermittent with too much noise	A. Out of communication range or obstructed by tall buildings. B. The 450 filter is broken, Contact local dealer for repair.
Loudspeaker is quieter or has crackling sound	Check whether the loudspeaker is broken, or if there is powder or dust in the loudspeaker. Contact local dealer for repair.
Receive voice from the other party but can not transmit	Check [PTT] key.
Receiving indicator with green light but no sound	A. Low volume, please turn the VOLUME knob clockwise. B. Loudspeaker is broken, Contact local dealer for repair. C. Earphone jack is broken, Contact local dealer for repair D. Volume switch is broken.

## o ATTACHED CHART

### CTCSS Frequency Chart

1	62.5	12	94.8	23	136.5	34	177.3	45	218.1
2	67.0	13	97.4	24	141.3	35	179.9	46	225.7
3	69.3	14	100.0	25	146.2	36	183.5	47	229.1
4	71.9	15	103.5	26	151.4	37	186.2	48	233.6
5	74.4	16	107.2	27	156.7	38	189.9	49	241.8
6	77.0	17	110.9	28	159.8	39	192.8	50	250.3
7	79.7	18	114.8	29	162.2	40	196.6	51	254.1
8	82.5	19	118.8	30	165.5	41	199.5	52	user-defined
9	85.4	20	123.0	31	167.9	42	203.5		
10	88.5	21	127.3	32	171.3	43	206.5		
11	91.5	22	131.8	33	173.8	44	210.7		

((( **1024 groups DCS frequency chart**

000	001	002	003	004	005	006	007
010	011	012	013	014	015	016	017
020	021	022	023	024	025	026	027
030	031	032	033	034	035	036	037
040	041	042	043	044	045	046	047
050	051	052	053	054	055	056	057
060	061	062	063	064	065	066	067
070	071	072	073	074	075	076	077
100	101	102	103	104	105	106	107
110	111	112	113	114	115	116	117
120	121	122	123	124	125	126	127
130	131	132	133	134	135	136	137
140	141	142	143	144	145	146	147
150	151	152	153	154	155	156	157
160	161	162	163	164	165	166	167
170	171	172	173	174	175	176	177
200	201	202	203	204	205	206	207
210	211	212	213	214	215	216	217
220	221	222	223	224	225	226	227
230	231	232	233	234	235	236	237
240	241	242	243	244	245	246	247

## o ATTACHED CHART

250	251	252	253	254	255	256	257
260	261	262	263	264	265	266	267
270	271	272	273	274	275	276	277
300	301	302	303	304	305	306	307
310	311	312	313	314	315	316	317
320	321	322	323	324	325	326	327
330	331	332	333	334	335	336	337
340	341	342	343	344	345	346	347
350	351	352	353	354	355	356	357
360	361	362	363	364	365	366	367
370	371	372	373	374	375	376	377
400	401	402	403	404	405	406	407
410	411	412	413	414	415	416	417
420	421	422	423	424	425	426	427
430	431	432	433	434	435	436	437
440	441	442	443	444	445	446	447
450	451	452	453	454	455	456	457
460	461	462	463	464	465	466	467
470	471	472	473	474	475	476	477
500	501	502	503	504	505	506	507
510	511	512	513	514	515	516	517
520	521	522	523	524	525	526	527
530	531	532	533	534	535	536	537

## o ATTACHED CHART

540	541	542	543	544	545	546	547
550	551	552	553	554	555	556	557
560	561	562	563	564	565	566	567
570	571	572	573	574	575	576	577
600	601	602	603	604	605	606	607
610	611	612	613	614	615	616	617
620	621	622	623	624	625	626	627
630	631	632	633	634	635	636	637
640	641	642	643	644	645	646	647
650	651	652	653	654	655	656	657
660	661	662	663	664	665	666	667
670	671	672	673	674	675	676	677
700	701	702	703	704	705	706	707
710	711	712	713	714	715	716	717
720	721	722	723	724	725	726	727
730	731	732	733	734	735	736	737
740	741	742	743	744	745	746	747
750	751	752	753	754	755	756	757
760	761	762	763	764	765	766	767
770	771	772	773	774	775	776	777

**NOTE: N stands for positive code. I stands for inverted code. 1024 groups of DCS in total.**



## ◦ FCC COMPLIANCE

### ((( Usage of Your Transceiver on Part 95 (Public) Frequencies

This radio has been type accepted and certified by the FCC for MURS Radio Service operation.

Any adjustments or alterations which might alter the performance of the transceiver or the method of determining frequency are strictly prohibited.

If you replace or substitute any unique parts (including crystals, transistors, IC's, regulator diodes, etc.) with parts other than those recommended by AnyTone Tech, you may be in violation of FCC technical regulations (in Part 95) or type acceptance requirements of the FCC rules.

Please Refer to PART 95 Subpart J - for more information regarding MURS Use.

## ◦ LIMITED WARRANTY (UNITED STATES)



**You MUST file your warranty information online at: [AnyToneTech.com](http://AnyToneTech.com) within 45 days of purchase.**

*AnyTone*<sub>tech</sub> will repair or replace, at its option without charge, subject to the exclusions set forth below, any *AnyTone*<sub>tech</sub> Two-Way -Radio transceiver which fails due to a defect in material or workmanship within ONE year following the initial consumer purchase.

This warranty does not apply to water damage, battery leak or misuse, use of unauthorized accessories, unauthorized service or modification or altered products. Accessories have a 90 day warranty from date of purchase, including antennas, batteries, chargers, and earphones.

ANY IMPLIED WARRANTIES, INCLUDING WITHOUT LIMITATION THE IMPLIED WARRANTIES OF MERCHANTABILITY AND FITNESS FOR A PARTICULAR PURPOSE, SHALL BE LIMITED AS SET FORTH HEREIN AND TO THE DURATION OF THIS LIMITED WARRANTY, OTHERWISE THE REPAIR OR REPLACEMENT AS AND IS PROVIDED UNDER THIS EXPRESS LIMITED WARRANTY IS THE EXCLUSIVE REMEDY OF THE CONSUMER AND IS PROVIDED IN LIEU OF ALL OTHER WARRANTIES, EXPRESS OR IMPLIED. IN NO EVENT SHALL *AnyTone*<sub>tech</sub> BE LIABLE, WHETHER IN CONTRACT OR TORT (INCLUDING BUT NOT LIMITED TO NEGLIGENCE, BODILY INJURY, PROPERTY DAMAGE AND DEATH) FOR DAMAGES IN EXCESS OF THE PURCHASE PRICE OF THE PRODUCT OR ACCESSORY, OR FOR ANY INDIRECT, INCIDENTAL, SPECIAL OR CONSEQUENTIAL DAMAGES OF ANY KIND, OR LOSS OF REVENUE OR PROFITS, LOSS OF BUSINESS, LOSS OF INFORMATION OR DATA OR OTHER FINANCIAL LOSS ARISING OUT OF OR IN CONNECTION WITH THE ABILITY OR INABILITY TO USE THE PRODUCTS OR ACCESSORIES TO THE FULL EXTENT THESE DAMAGES MAY BE DISCLAIMED BY LAW.

## o ANYTONE TECH'S LETTER TO YOU:

*AnyTone*<sub>tech</sub> specializes in communication equipment, but even more important than communication with others - is your communication with God.

To become a Christian and receive salvation is the greatest step you can take with God. To be real it must be a personal commitment from the heart. Here are three steps to eternal salvation.

1. Admit you are a sinner. "All have sinned and come short of the glory of God" (Roman 3:23).
2. Receive Jesus Christ as Savior. "But as many as received him, to them gave he power to become the sons of God" (John 1:12).
3. Confess your faith. "That if thou shalt confess with thy mouth the Lord Jesus, and shalt believe in thine heart that God hath raised him from the dead, thou shalt be saved." (Romans 10:9).

To believe on Jesus Christ as Savior means to believe that He died for you, believe that He paid the price for your sin, and believe that He is the only way to Heaven. You can express your belief on Jesus by calling on Him in prayer.

Trusting God as your savior is the most important item we promote at *AnyTone*<sub>tech</sub>. We would like to help you learn more if you have accepted Christ as your personal Savior - contact us today at: [AnyToneTech.com](http://AnyToneTech.com) to let us know and we will send you a one time package of literature.

The SAR limit of USA (FCC) is 1.6 W/kg averaged over one gram of tissue. Device types TERMN-8R, OBLTR-8R has also been tested against this SAR limit. The highest SAR value reported under this standard during product certification for use when properly worn on the body is 0.109 W/kg and for head is 0.061 W/kg. . This device was tested for typical body-worn operations with the back of the handset kept 25mm from the body. To maintain compliance with FCC RF exposure requirements, use accessories that maintain a 25mm separation distance between the user's body and the back of the handset. The use of belt clips, holsters and similar accessories should not contain metallic components in its assembly. The use of accessories that do not satisfy these requirements may not comply with FCC RF exposure requirements, and should be avoided.