

Instructions

FreeXwire models FW8R and FW9T

Digital Receiver/ Digital Transmitter / Digital Wireless TTL Flash and Camera Trigger

Quantum Instruments Inc.

1.0 Introduction

We introduce you to the newest additions to the FreeXwire system: Receiver **FW8R** and Transmitter **FW9T**.

Transmitter **FW9T** emits higher power for extended range. Receiver **FW8R** has extra sensitivity and simplified operation.

Both **FW8R** and **FW9T** are fully compatible with all FreeXwire system components including Receiver FW7Q and Transceiver FW10.

FreeXwires provide wireless sync for remote flash and/or wireless shutter control for remote camera operation. **FW8R** and **FW9T** can provide wireless TTL flash control from digital and film cameras to Qflash T5d (Qflash 4d models can be upgraded). This wireless TTL feature also transmits the "pre-flash" signal for digital cameras.

FreeXwire controls four independent *Zones* for wireless flash or motor drive. You can activate any one Zone, or any combination of Zones 1,2,3 and 4. Switch your lighting instantly, remotely. Select and trigger flash, cameras, or combinations of them, from your remote position.

FreeXWire also has eight unique *Channel Codes*. FreeXwire units set to one Channel cannot activate FreeXwires set to different Channels. You control the Channel Code to make FreeXwire units work together or independently, as required.

FreeXWire is very small and light and mounts easily to cameras, brackets, poles, and tripod legs. Sync and motor drive cords are available for popular cameras and flashes. You can mount Transmitter FW9T directly on camera hot shoes using optional UniMod FW11 or Hot Shoe Adapter FW12.

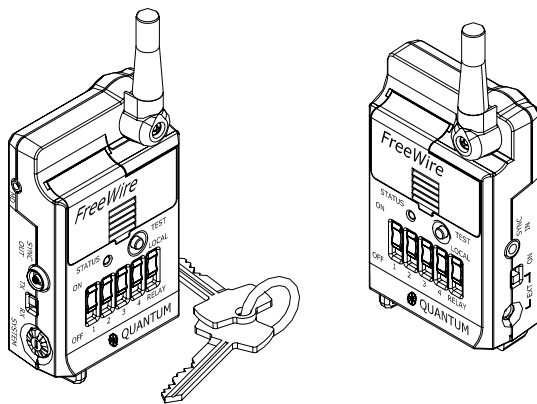

FreeXwire Instructions -- Contents:

Section

- 1.0 Introduction
- 2.0 Channel Code and Zone set-up
- 3.0 Remote Flash set-up
- 4.0 Remote Shutter set-up (with or without *on-camera* flash)
- 5.0 Mounting FreeXwire
- 6.0 Qflash T4 Remote Operation
- 7.0 Wireless TTL and Wireless Auto with Qflash
- 8.0 Miscellaneous
- 9.0 FreeXWire Performance Guide

- Appendix A Sync-in connections- camera to FreeWire FW9T
- Appendix B Sync-out connections- Receiver FW8R to flash
- Appendix C Motor Drive cords- Receiver FW8R to camera
- Appendix D TTL Wireless Adapters for FreeWire FW9T
- Appendix E Miscellaneous connections
- Appendix F Specifications

Customer Service
Limited Warranty

Included with FreeXwire model FW8R:

Pole mounting kit, 2x AAA batteries, Instructions, Hook and loop mounting pads

Included with FreeXwire model FW9T:

2x AAA batteries, Sync-in cord, Instructions

All specifications and features are subject to change, updating, and improvements.

Glossary

Receiver FW7Q	-- a FreeXwire receiver unit dedicated for Qflash model T4
Receiver FW8R	-- a FreeXwire receiver unit
Transmitter FW9T	-- a FreeXwire transmitter unit
Transceiver FW10	-- a FreeXwire transceiver unit (can be set as transmitter or receiver).
Hot Shoe Adapter FW12	-- a FreeXwire hot shoe adapter to mount FW9T on camera shoe
Zones 1, 2, 3, and 4	-- wireless links that can be turned on or off to change lighting and camera activation
Channels 0 thru 7	-- independent channels for separate FreeWire setups operating in the same area
"Local" flash	-- a flash close to the camera and connected with a sync cord
"Remote" flash	-- a flash at a distance from the camera and wirelessly synchronized

2.0 Channel Code and Zone set-up

2.1 Setting the Channel Code and Zones

The Channel Codes allow FreeXwires to work together. Set all units that you want to work together to the same Channel Code. If you desire independent groups of FreeXwires (to work in the same area but not interfere), assign each group of FreeXwires its own Channel.

The Channel dial is located on the left side. Rotate the dial to the desired Code, 0 through 7. To rotate, press the pad of your thumb on the dial and turn. Or, use a small screwdriver. Channels can be matched by number or by the position of the cutout in the Channel dial.

Put AAA batteries in all units.

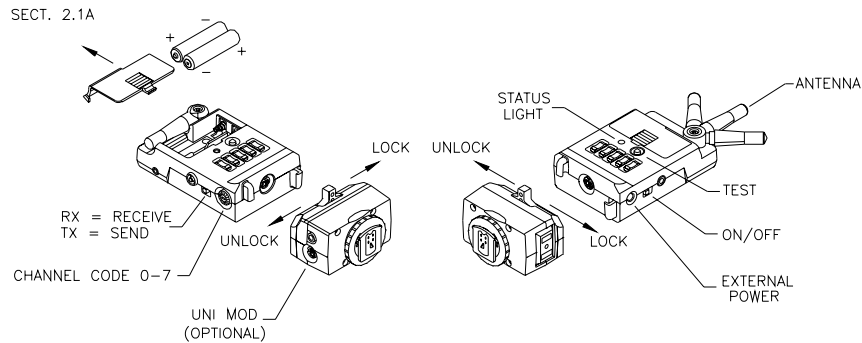

Activate at least one Zone on both FW8R and FW9T by sliding Zone switches 1, 2, 3, and/or 4 up, towards the "+" symbol. Any FW8R and FW9T Zones that match will activate FW8R units each time the FW9T unit transmits. There are many possible combinations and you can change them as you work. To deactivate a Zone slide its switch down towards the "-" symbol.

SECT. 2.1B

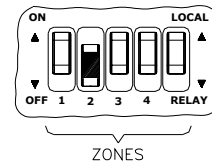

2.2 Turn on the units.

Slide the power switch to ON. Status lights of FW9T units blink *red slowly*. FW8R units blink *green slowly*. Low batteries are indicated by *3 quick blinks* every few seconds.

Open the antennas so that they are approximately vertical. See Section 5.0, Mounting FreeWire.

Press TEST on the Transmitter FW9T to confirm that all units are working. STATUS should light *steadily* on all FreeXwires FW8R's for as long as you hold TEST (assuming correct Channel and Zone settings.)

The optional Hot Shoe adapter FW12 may be connected to the Transmitter FW9T. The purpose of the Hot Shoe Adapter is only to provide hot shoe mounting and sync from a camera to a Transmitter FW9T. FW12 will not provide TTL control -- see the chart (Appendix D) for selection of QTTL and other TTL adapters.

3.0 Remote Flash set-up

3.1 Transmitter FW9T:

Connect a sync-in cord from your camera PC nipple to FW9T Sync-In. Or use the optional FW12 to connect FreeWire to your camera's hot shoe.

(See Appendix A for other sync-in options.)

If you want to sync a "local" flash as well as a remote one, connect the flash manufacturer's PC sync cord to the Sync-Out PC nipple on Transmitter FW9T, and set the Local switch to "+". To turn off the local flash, switch to "-".

If Qflash is the "local" flash, connect FW31 from Qflash to FW9T DIN socket or FW12 DIN socket. Then, Qflash can power the FW9T by setting the power switch to "off" (EXT). The battery will not be needed in the FW9T.

3.2 Receiver FW8R:

Connect the PC sync cord supplied by your flash's manufacturer to the Sync-Out PC nipple or Phono socket on the FW8R. (See Appendix B for other sync-out options.)

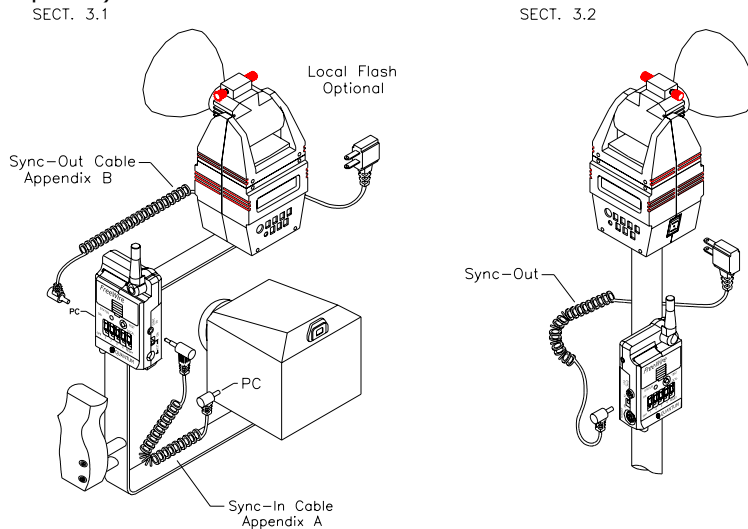

In general, set the RANGE switch to NORM. This setting works to distances to about 400-500' (125-150m). If you require greater range, set RANGE to HI which may double the range. However, whenever using FreeWire for wireless TTL, always use NORM range.

3.3 Receiver FW7Q: This receiver is dedicated to Qflash 4d and 5d models. See instructions included with the FW7Q if you wish to employ this receiver with your FreeWire system.

4.0 Remote Shutter set-up (with or without *on-camera* flash)

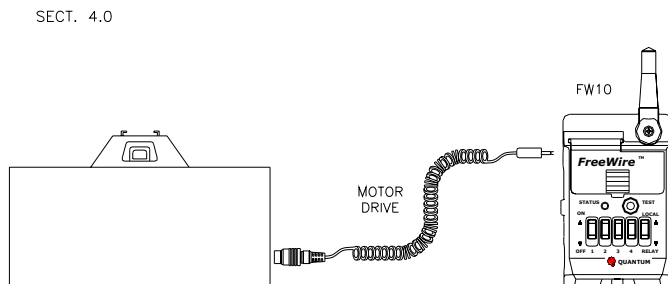

4.1 Receiver FW8R: Connect a Motor Drive Cord (see Appendix C) from the Receiver FW8R MD connection to your camera motor drive.

4.2 Transmitter FW9T: Press TEST and hold (up to 1 second) to activate the camera motor drive. Test your camera -- some require time to wake-up and to auto focus before they release the shutter.

4.3 MD Delay on FW8R:

Many cameras have two step shutter buttons: Pressing part way on the meter and auto focusing, and pressing all the way releases the shutter. Some of these cameras require a delay between the meter/focus function and shutter release (for example, Contax 645). Select MD Delay for those cameras by sliding **MD DELAY** switch to "+". Without MD Delay, the camera focus,

meter, and shutter will be activated together (and the camera will shoot as soon as it can). The MD Delay requires a two step motor drive cable listed in Appendix C. Motor drive cables will be added periodically, so please consult your dealer or the Quantum Web Site (qtm.com) for the latest models available.

5.0 Mounting FreeXwire

FreeXwire units mount by several means:

5.1 Pole Mount Adapter 513: This item is included with your Receiver FW8R. Attach it to the back of FreeXwire and clamp it around any pole, leg, or structure where the antenna can be opened away from metal objects.

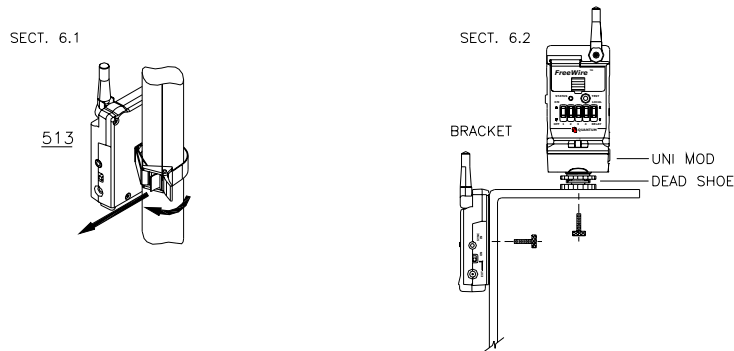

5.2 Mounting directly to a bracket: Use the #8/32 screw included with FreeWire to secure it through a hole in a bracket. *Any other screw used must protrude not more than 3/4" (2 cm) into the FreeXwire case, or you will damage FreeXwire!*

5.3: Direct Hot Shoe Mounting with FW12 or the Uni-Mod FW11

Connect the Hot Shoe Adapter FW12 or Uni-Mod FW11 to a Transmitter FW9T and slip it into a camera hot shoe.

connect a separate motor drive cord (Appendix C) between MD out and the camera motor drive.

You may also mount the FW12 or FW11 to a "dead" shoe for convenience, in which case sync-in (for FW9T units) or sync-out (for FW8R units) connections will be necessary.

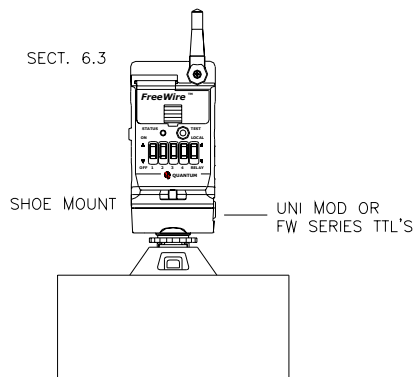

A Receiver FW8R mounted to Uni-Mod on a camera shoe will have no connection to the motor drive. If you desire remote motor drive triggering,

5.4: Mounting with hook & loop tape: Two sets of hook & loop fasteners and one mounting pad are included in the package.

5.5: Important notes on antenna orientation:

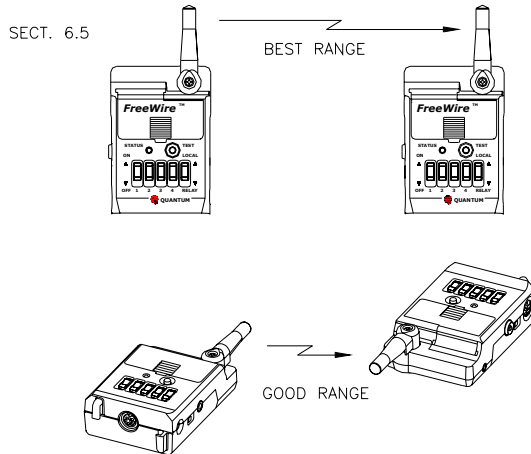

At close range (about 50' or 16m) antenna orientation is not critical. Antenna orientation matters more as distance between Transmitter FW9T and Receiver FW8R increases.

The best mounting positions keep FreeWire antennas away from metal objects. Each antenna should be parallel to all others. Vertical FreeWires with vertical antennas provide the greatest range. Other orientations work almost as well.

Also see Section ,FreeWire Performance Guide, for further information.

6.0 Qflash Remote Operation

FreeWire provides wireless control of Qflash 4d or 5d series operation and settings, letting you change settings on remote Qflashes.

In addition to Receiver FW8R and Transmitter FW9T, you will need two FW31 cables to connect each FreeWire unit to the local and remote Qflashes. The Qflash 4d/5d instructions manuals detail operating instructions for adjusting the settings on the remote Qflash(es) via wireless mode.

7.0 Wireless TTL control for *Digital Cameras*

Receiver **FW8R** and Transmitter **FW9T** provide wireless TTL flash capability for popular digital cameras. With "Dw" series QTTL adapters (e.g. D12w, D13w, etc.) and Qflash series 5d flashes, even the pre-flash signals from digital cameras will be sent wirelessly to remote Qflashes. (Note: All Qflash 4d series flashes can be converted to Qflash 5d, and all D series adapters can be converted to "Dw" series via software upgrade. Please contact Quantum for details.)

Set all Qflash's to "TTL" mode. ". Set Receiver FW8R Range to "NORM"

7.1 Transmitter FW9T set-up

Select the correct type Quantum "Dw" series TTL adapter for your camera (Appendix D, or www.qtm.com for latest additions). Mount the Dw series adapter to the camera and connect its cable to the FW9T Accessory socket. Mount FW9T on a bracket or other location.

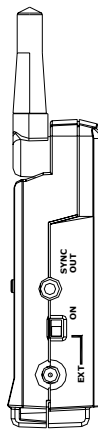

Set Transmitter FW9T TTL switch to ON.

7.2 Receiver FW8R set-up

Connect FW31 Accessory Cable between the Receiver FW8R and a Qflash 5d Accessory socket. **Set Qflash to TTL mode. Set Receiver FW8R Range to NORM.**

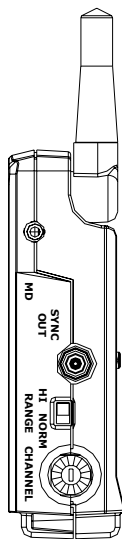

7.3 Connecting a local Qflash to the Transmitter FW9T:

If you wish to use a local Qflash 5d to fire with the remote Qflash, connect the "Dw" series TTL Adapter to one Qflash Accessory socket. Connect the FW9T to the other Accessory socket with an FW31 accessory cable.

Set Qflash 5d to QTTL mode. Qflash cannot be turned off with the Local switch on FW9T, however, Qflash 5d can be turned off by pressing MODE twice. To restart, press any button on Qflash.

8.0 Wireless TTL control for *Film Cameras*

Receiver **FW8R** and Transmitter **FW9T** provide wireless TTL flash capability for film cameras that do not require a pre-flash pulse. All series of Qflash and all series of TTL adapters can be used. These include Qflash T/X, 2/2d, 4d and 5d series, and TTL adapter series QF, FW, D, and Dw.

8.1 Transmitter FW9T set-up:

Select the correct type of Qflash TTL Adapter for your camera, from the list in Appendix D. The "FW" series of TTL adapters attach to Transmitter FW9T and to the camera hot shoe without cables. The "QF" series and "D" series of TTL Adapters connect to Transmitter FW9T accessory socket. Mount Transmitter FW9T on a bracket or other location.

Set Transmitter FW9T TTL switch to ON

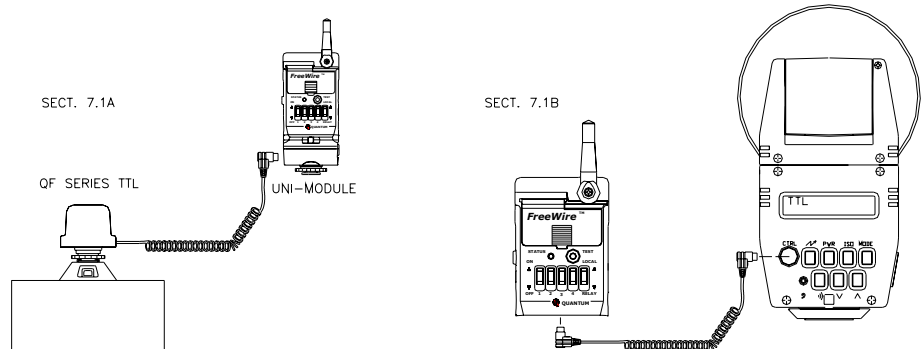

8.2 Receiver FW8R:

Connect FW31 Accessory Cable between the Receiver FW8R and Qflash Accessory socket. **Set Qflash to TTL mode.**

Note: Qflash powers FreeWire when it is connected with the QF31 cable. Set the power switch of FreeWire to EXT.

8.3 Connecting a local TTL Qflash to the Transmitter FW9T:

A local Qflash connected to FW9T will sync with the remote flash and will also power the FW9T. Set the power switch of the FW9T to EXT.

Set Qflash to TTL mode

9.0 Wireless Auto Control of Remote Qflash

With today's complicated camera systems, it is sometimes easier, more reliable and straightforward to shoot in auto mode rather than TTL. Auto also gives the photographer the ability to tailor her/his exposures to personal taste or experience.

This mode will allow a **any** model of Qflash in Auto mode to control its exposure and the exposures of remote Qflashes. This set up **does not** require a camera with TTL capability **nor** a TTL Adapter. It does require a local Qflash and will work with non-pre-flash cameras.

9.1 Transmitter FW9T set-up:

Connect an FW31 cable from Transmitter FW9T to Qflash. Connect a Sync-in cord from camera PC nipple to Transmitter FW9T. **Set the local Qflash to Auto mode.**

9.2 Receiver FW8R:

Connect an FW31 cable from FreeWire RX to the remote Qflash as in diagram 7.3b. Connect as many remote Qflash's as required. **Set the remote Qflashes to TTL mode.** The remote TTL Qflashes will expose to the setting of the local "Auto" Qflash.

9.3 Additional features with Qflash 4d/5d models

With a Qflash 4d/5d and Transmitter FW9T connected to the camera, many other Wireless Auto features are available. Note that the *remote* flash can be *any* Qflash model:

The available features include:

Wireless ratio control between Qflashes;
Wireless auto fill and auto exposure offset, tracking the camera's f/# setting as it changes. (D or Dw series adapter on the camera required).

Full details of these features can be found in the Qflash 5d operating manuals.

10.0 Miscellaneous

10.1 High Speed Sync for remote flash:

For highest sync speeds do this: Turn on all zones of Receiver FW8R units. This "high speed sync" allows shutter speeds up to 1/500 for focal plane and 1/1000 for leaf shutters. TTL mode does not work with high speed sync.

"Normal sync" speeds are 1/250 for focal plane and 1/500 for leaf shutters (or slower) when selecting one, two or three of the Zones on any FreeWire RX unit.

10.2 External Power:

You can power FreeWire externally with AC adapters, Quantum Batteries, or with a Qflash connected by an FW31 Accessory cable. Appendix E lists AC adapters that connect to the EXT power jack. To utilize external power, switchFreeXwire OFF (EXT). When external power is removed, switchFreeXwire ON to power it from its internal batteries.

Warning: Use only Quantum specified external power to avoid possibly damaging FreeWire.

11.0 FreeWire Performance Guide

How to maximize performance, troubleshoot, and answer questions about Quantum's FreeWire Wireless Photo Control System.

If for some reason we don't have an answer in this guide, please email, fax, write or call Customer Service for further assistance.

Good radio performance depends on several factors: The orientation of a radio and antenna, the presence of other radio signals which may interfere, and the presence of objects which may interfere. As the range increases, these issues become more important. At close range, performance is less critical.

The following suggestions will maximize range and reliability of your FreeWire link:

Orientation

The ideal orientation is with all FreeWire antennas opened vertically and all antennas parallel. If FreeWire is attached to a camera and you change from vertical to horizontal

framing, you can easily swing the FreeWire antenna back to vertical.

When switching repeatedly from horizontal to vertical framing, you may set the TX antenna at 45° as shown. That will provide reasonable range without adjusting the antenna with every shot.

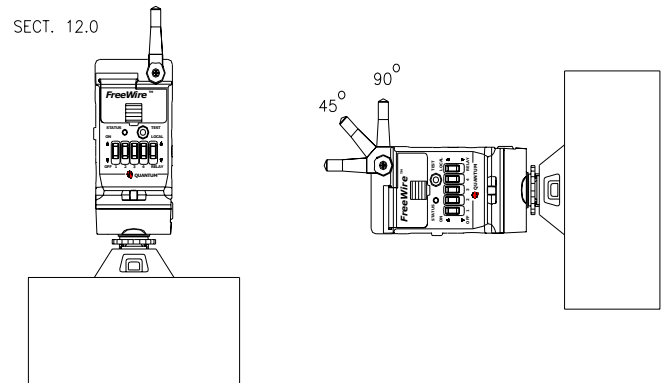

Mounting and placement

The enemies of radio signals are metal objects, concrete, and water. Mount FreeWire's away from metal objects when possible. Of course, you may be mounting on light stands and brackets, and they generally have a slight affect on range.

At longer ranges it is possible to find dead spots. Moving the FreeWire Remote unit a few inches in any direction can cure the problem.

Do not use gaffers or duct tape which have metal threads imbedded, on any FreeWire. Do not mount metallic labels on the units.

When wearing FreeWires, mount them outside your clothing and away from your body. And, or course, watch out for metal objects on you.

Transmitter FW9T units may be mounted close together. FW9T units will trigger FW8R units from a distance of about 3 foot (1m) up to the maximum range.

Interference

Keep FreeWire receivers away from flash units and generators that generate radio interfering signals. That is also true of most any heavy machinery, motors, and of course other transmitters. Arenas, factories, and offices have other sources of radio "noise" which can include TV camera uplinks, walkie-talkies, radio and TV broadcast antennas, and cell phone repeaters.

If you cannot remove FreeWire receivers from interference, close the *receiver* antennas which will decrease interference, or set FW8R **SEN** switch to "lo", however decrease the range as well.

APPENDICIES

Accessories may be changed or added periodically. Please consult you dealer or the Quantum Web page (www.qtm.com) for the latest models available.

Appendix A -- Sync-in connections from camera to Transmitter FW9T

Model	Description	From	To	Notes
434	Sync-in cord- 18" (.5m)	Camera PC nipple	FreeWire Sync-In	Coiled cord
435	Sync-in cord- 4' (1.2m)	Camera PC nipple	FreeWire Sync-In	Coiled cord
470	Hasselblad sync cord	Hasselblad "C" lens	FreeWire Sync-In	
FW20	Sync-in cord- 18"(.5m)	Camera PC nipple	FreeWire Accy conn	
FW21	Hot Shoe sync- 18" (.5m)	Camera hot shoe	FreeWire Accy conn	
FW22	Hot Shoe sync- 18" (.5m)	Camera hot shoe	FreeWire Sync-In	

The following require a Uni-Mod connected to your Transmitter FW9T unit:

Model	Description	From	To	Notes
QF53	Hot Shoe Adapter	Camera hot shoe	Uni-Mod two prong	
536	Sync-in cord, 18" (.5m)	Camera PC nipple	Uni-Mod two prong	Coiled cord
537	Sync-in cord, 5' (1.5m)	Hasselblad "C" lens	Uni-Mod two prong	Coiled cord
539	Sync-in cord, 12" (.3m)	Camera PC nipple	Uni-Mod two prong	Straight cord

[Note: #536 and 537 serve as Sync-out cords as well- see Appendix B]

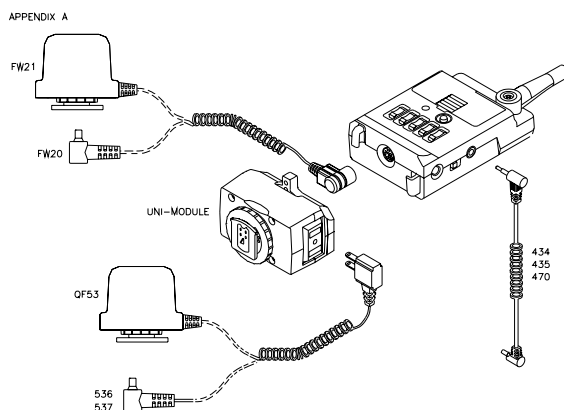

Appendix B -- Sync-out connections from FreeWire FW8R to flash

Model	Description	From	To	Notes
----	flash mfg's sync cord	FreeWire PC conn.	Your flash	Supplied by flash manufacturer
FW31	Accy cable- 18"(.5m)	FreeWire Accy conn.	Qflash Accy conn.	For Qflash sync or wireless TTL.
534	Sync-out cord 18" (.5m)	FreeWire PC conn.	2 prong	for Studio flash
535	Sync-out cord 5' (1.5m)	FreeWire PC conn.	2 prong	"
536	Sync-out cord 18" (.5m)	FreeWire PC conn.	2 prong + pin	For QFlash and some studio flash
537	Sync-out cord 5' (1.5m)	FreeWire PC conn.	2 prong + pin	"

[Note: #536 and 537 serve as Sync-in cords as well- see Appendix A]

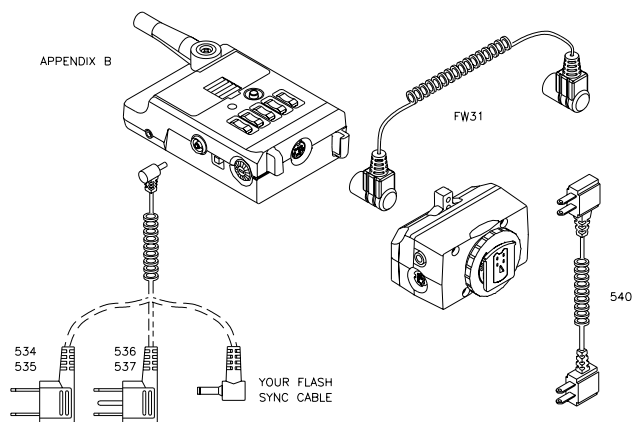

Note on Sync-out and Sync-in cords:

Paramount Cords makes many cords that fit FreeWire. For reference, the Sync-in requires a 3.5mm phone plug, and the Sync-out fits a PC male plug. There is a second Sync-out connection on the Uni-Mod that fits a 3.5mm plug.

Appendix C -- Motor Drive cords from FreeXwire to camera

Model	Cameras	Notes
451	Nikon MD2/4/12/15, 8008/s, F4S	N90/s, F5, F100 need Nikon adapter MC25
452	Hasselblad ELM, ELX	
453	Canon, Olympus, Bronica SQAM, ETR md	See other Canon selections
454	Mamiya RZ67, RZ67 II, 645 Super, 645 Pro	
456	Leica	
458	Minolta 5000/i, 7000/I, 8000/I, 9000/I, 5Xi, 7Xi, 9Xi, 700si	
459	Canon EOS A5, A2E, A2, 1, 1N, 620, T90	
463	Bronica SQAI	
464	Rollei, 6006, 6008, 6003, 6002, SLX	
465	Hasselblad 503CW/CXi	
466	Canon EOS-3, 1V, D30, D2000	
467	Mamiya 645AF	
FW41	Contax 645, Canon Elan 2,2E,7,7E Rebel 2000, XI Lite	Two step MD cord
FW42	Minolta 7 & 9	Two step MD cord
FW43	Canon EOS 1v, 3, D2000, D30	Two step MD cord
FW44	Nikon D1, N90/s, F5, F90x, F100	Two step MD cord
FW45	Mamiya 645AF	Two step MD cord
FW46	Canon EOS 1, A2, A2E, AS, 1N, 620, T90	Two step MD cord

Appendix D -- TTL Wireless Adapters for Transmitter FW9T

These TTL Adapters connect to a FreeWire TX and provide wireless TTL exposure control.

QF Series** TTL Adapters	FW Series* TTL Adapters	Cameras
QF10		Olympus, Practica
QF11		Minolta X series
QF12	FW52	Nikon
QF13N	FW53N	Canon
QF14		Minolta Xi series
QF15		Contax
QF16		Leica
QF17	FW57	Pentax

QF18		Rollei
QF19	FW59	Hasselblad
QF20	FW60	Bronica
QF22		Mamiya
QF23		Leica
QF24	FW64	Contax
QF25	FW65	Mamiya 645

* FW series TTL Adapters connect directly to the Transmitter FW9T

** QF series TTL Adapters require a Uni-Mod connected to FreeWire TX, unless a Qflash is also connected to the Accessory connector of FreeWire:

Adapters models may be updated periodically. Please check the latest Quantum Price List at your dealer, or www.qtm.com. Look under Qflash and FreeWire.

Appendix E -- Miscellaneous Connections

Model	Description
FW33	Y Connector for Transmitter FW9T to connect a TTL adapter plus a local Qflash and FW31 cable.
MDC2	External power connection from QB1, 1+, or QB1c to FreeWire:
XDC2	External power connection from Bantam or QB1c to FreeWire:
FW26	Multi-clip for use as belt, light stand or bracket attachment for FreeWire
FW29	AC external adapter, US & Can, 115 VAC

Appendix F -- Specifications

Size: FreeWire FW8R/FW9T: 3.6 x 2.3 x 1.1 in. (9 x 6 x 2.8 cm)

Weight (w/ batteries): Receiver FW8R/FW9T: 4.3 oz (122g)

Batteries: 2x AAA cell alkaline, nicad, nickel-metal hydride, or lithium

Battery life: (Alkalines): FW8R: receiving four shots per minute: 24000 shots, 100 hours;
FW9T: sending four shots per minute: 36000 shots, 150 hours

Connected to Qflash with FW31 cable: Powered by Turbo Battery.
(batteries may be left in unit)

Battery life- after low battery signal (triple blink every 2 seconds): approx. 1-3 hours

Maximum Range: Varies with local conditions- up to 750' (250m)

Maximum flash rate: 25 fps

Maximum sync delay from camera trigger to remote flash: 1/2000-sec normal sync; 1/3000 sec. (all RX Zones ON – fast sync mode).

Minimum camera shutter speeds: Leaf shutters 1/500 , 1/250 focal plane shutters. In fast sync mode (All RX Zones ON) sync speeds may be 1/1000 for leaf shutters, 1/500 for focal plane shutters.

Batteries: Receiver FW8R/FW9T supplied with 2 x AAA. External power is supplied whenever FreeWire is connected to Qflash with FW31 cord. External power required 5-7 volts, center positive.

All equipment, specifications and descriptions are subject to changes, improvements and availability.

[back cover]

[box outs on this page shall be included]

[logo] **FCC** Tested to comply with FCC standards

CANADA: FCC ID: CEXFW8R/CEXFW9T
FreeXwire models FW8R/FW9T

This device complies with Part 15 of the FCC Rules and with RSS-210 of Industry & Science Canada. Operation is subject to the following conditions: 1) this device may not cause harmful interference, and 2) this device must accept any interference received including that which may cause undesired operation of the device.

IMPORTANT - CAUTION

Changes or modifications to this equipment could void your authority to use this product under the equipment authorization granted by the regulating agencies.

[logo] **CE**

Declaration of Conformity: Quantum Instruments, Inc. declares that FreeWire FW10 satisfies all the technical regulations applicable to the product within the scope of Council Directive 1999/5/EC.

For Customer Service, technical help, or information:

Quantum Instruments Inc
1075 Stewart Ave. Garden City NY 11530 USA

PH: 1-516-222-6000 FAX: 1-516-222-0569
Web: www.qtm.com Email: QuantRep@qtm.com