



GSM/GPRS/GPS Tracker **GL300**
User Manual

TRACGL300UM001

Revision: 1.01



<http://www.queclink.com>
sales@queclink.com

Document Title	GL300 User manual
Version	1.01
Date	2013-06-25
Status	Release
Document Control ID	TRACGL300UM001

General Notes

Queclink offers this information as a service to its customers, to support application and engineering efforts that use the products designed by Queclink. The information provided is based upon requirements specifically provided to Queclink by the customers. Queclink has not undertaken any independent search for additional relevant information, including any information that may be in the customer's possession. Furthermore, system validation of this product designed by Queclink within a larger electronic system remains the responsibility of the customer or the customer's system integrator. All specifications supplied herein are subject to change.

Copyright

This document contains proprietary technical information which is the property of Queclink Limited., copying of this document and giving it to others and the using or communication of the contents thereof, are forbidden without express authority. Offenders are liable to the payment of damages. All rights reserved in the event of grant of a patent or the registration of a utility model or design. All specification supplied herein are subject to change without notice at any time.

Copyright © Queclink Wireless Solutions Ltd. 2013

Contents

Contents	2
0. Revision history	3
1. Introduction.....	4
2. Product Overview	5
2.1. Appearance.....	5
2.2. Buttons/Mini USB Interface Description	5
2.3. LEDs Description.....	6
2.4. External Power Interface.....	6
2.4.1. External DC Charger Interface.....	6
2.4.2. External Battery Interface	7
2.5. Ignition Detection.....	7
2.6. External Input Interface.....	8
3. Getting Started	9
3.1. Parts List.....	9
3.2. Battery Charging	9
3.3. GL300 External Cable Interface.....	10
3.4. Install SIM Card	10
3.5. Turn on/Turn off	11
4. Troubleshooting and Safety info	12
4.1. Troubleshooting.....	12
4.2. Safety info	13

0. Revision history

Revision	Date	Author	Description of change
1.00	2013-04-18	Tony PEI	Initial
1.01	2013-06-25	Tony PEI	Add the FCC warnings in Introduction

1. Introduction

GL300 is a powerful GPS Tracker designed for asset, vehicle, and pet tracking. With superior receive sensitivity, fast TTFF (Time to First Fix) and Quad band GSM frequencies 850/900/1800/1900, its location can be continuously monitored or periodically reported to a backend server or other device. Based on the embedded @Track protocol, the GL300 can communicate with the backend server through the GPRS/GSM network (or SMS) to report emergency alerts, Geo-Fence boundary crossings, low battery and scheduled GPS positions along with several other advanced reporting features. System integrators can easily setup their custom tracking platforms to communicate with the GL300 based on the @Track protocol.

This device complies with Part 15 of the FCC Rules. Its operation is subject to the following two conditions:

- (1) This device may not cause harmful interference, and
- (2) This device must accept any interference received, including interference that may cause undesired operation.

Note: This product has been tested and found to comply with the limits for a Class B digital device, pursuant to Part 15 of the FCC Rules. These limits are designed to provide reasonable protection against harmful interference in a residential installation. This product generates, uses, and can radiate radio frequency energy and, if not installed and used in accordance with the instructions, may cause harmful interference to radio communications. However, there is no guarantee that interference will not occur in a particular installation. If this product does cause harmful interference to radio or television reception, which can be determined by turning the equipment off and on, the user is encouraged to try to correct the interference by one or more of the following measures:

- Reorient or relocate the receiving antenna.
- Increase the separation between the equipment and receiver.
- Connect the equipment into an outlet on a circuit different from that to which the receiver is connected.
- Consult the dealer or an experienced radio/TV technician for help.

RF Exposure Statement: For the product, under normal use condition is at least 20cm away from the body of the user, the user must keep at least 20cm distance to the product.

2. Product Overview

2.1. Appearance



2.2. Buttons/Mini USB Interface Description

Button /Mini USB Interface Description	
Power Key	<ul style="list-style-type: none"> ● Turn on GL300 ● Turn off GL300 when without charging. (If power key is enabled)
Function Key	<ul style="list-style-type: none"> ● Geo-Fence mode Long press the key to enable/disable Geo-Fence ID0 ● Geo-Fence in current position mode Long press the key to enable/disable Geo-Fence ID0. If enable Geo-Fence ID0, using the current position as the centre of Geo-Fence 0. ● SOS mode (default) Long press the key to active SOS alarm
Mini USB interface	<ul style="list-style-type: none"> ● Connect a 5V DC adapter can power GL300 and charge the internal battery ● Connect a 3.7V Li-ion or Li-Polymer battery can power GL300

	<ul style="list-style-type: none"> Backend server developer or administrator can use the Data_Cable_M to configure GL300
--	---

2.3. LEDs Description

There are three LEDs in GL300, the description as following.

LED	Event	State
GSM LED	Searching network	Fast flash
	Network has been registered	Slow flash
	Power off	Dark
	SIM-PIN Locked	Solid
	Receives a valid protocol command	Turn on for 3 seconds
	<LED on> is 2	Dark
GPS LED	GPS has fixed	Solid
	GPS is in fixing	Fast flash
	GPS is on and GPS data wrong	Slow flash
	GPS is off	Dark
	If <LED on> is 0, 150 seconds later after powers on.	Dark
	<LED on> is 2	Dark
Power LED	Power on and normal	Dark
	Charger inserted and charging completed	Solid
	Charger inserted and charging	Fast flash
	Power key was pressed and prepare to power off	Fast flash
	Abnormal	Fast flash
	Power low alert	Slow flash
	Power off or turn off the power light by command	Dark
	<LED on> is 2	Dark

2.4. External Power Interface

2.4.1. External DC Charger Interface

The Pin2 on Mini-USB connector are used for charging and named as VCHG pin, It can be connected to a 5V DC power supply to power GL300 and charge the internal battery.

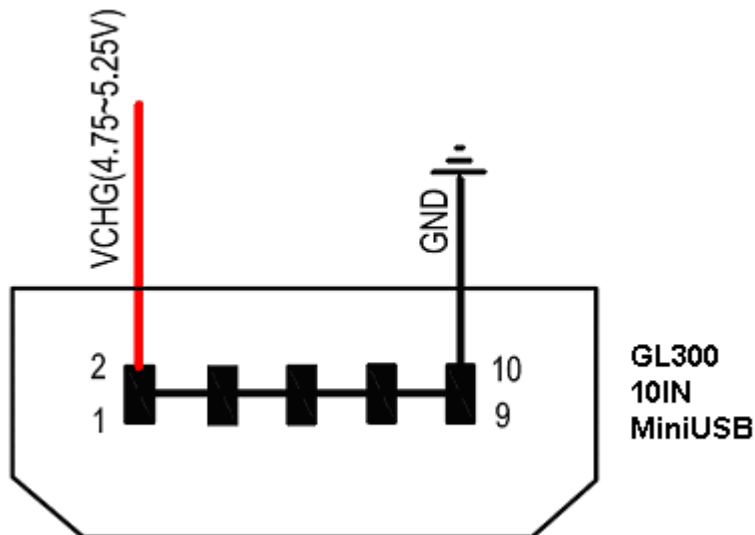

2.4.2. External Battery Interface

The Pin 8 on Mini-USB connector is for external battery and named as EXTBAT pin. It can be connected to 3.7V Li-ion or Li-Polymer battery to power GL300.

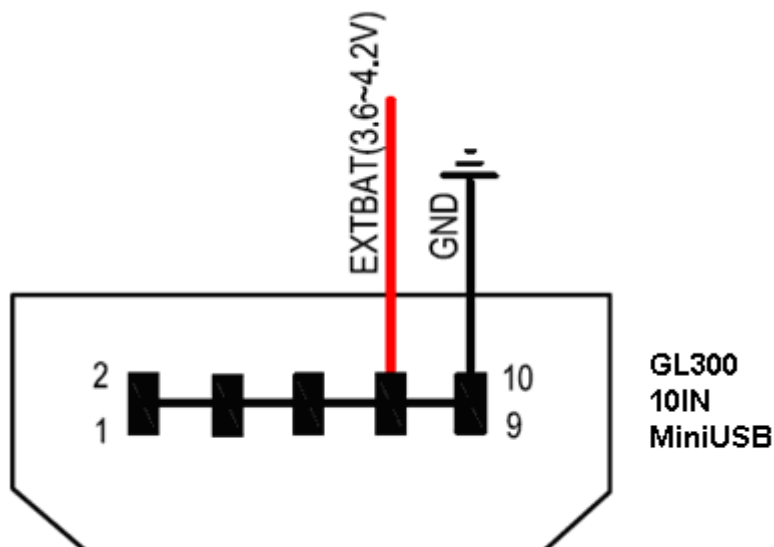

2.5. Ignition Detection

The Pin 7 on Mini-USB connector is for ignition detection when GL300 is used in vehicle tracking application. It is named as IGN_IND pin.

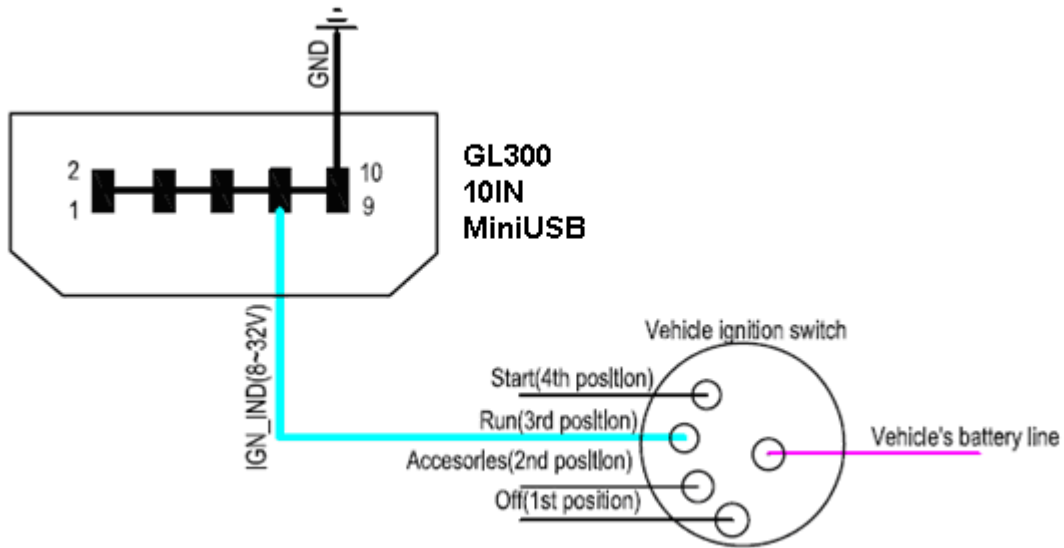

Another easy way is to connect PIN7 to a power output in the fuse box of the vehicle which is only enabled after the vehicle is ignition on. For example: the power output for radio FM.

2.6. External Input Interface

The Pin 5 on Mini-USB connector is a negative trigger input in newer hardware version. It is named as NSW pin.

For negative trigger input the electrical conditions are:

Logical State	Electrical State
Active	0V to 0.8V
Inactive	1.7V to 32V or Open



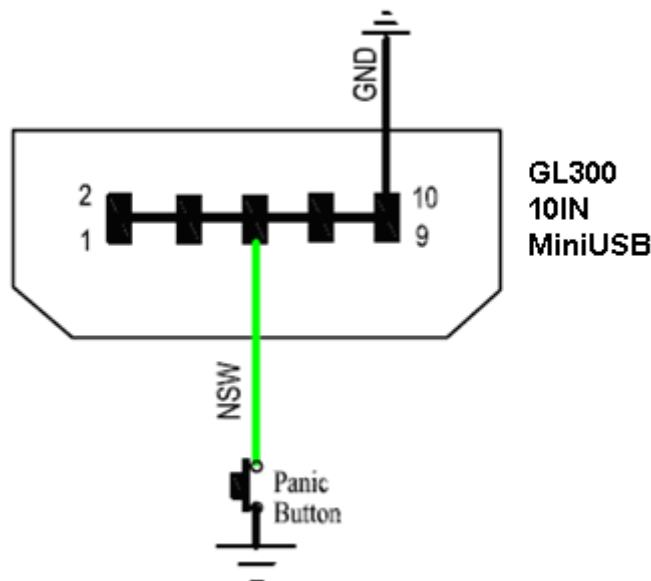

An input example is shown as following figures:



Example of NSW pin connect to a panic button

3. Getting Started

3.1. Parts List

Name	Picture	Remark
GL300 Locater		The GSM/GPRS/GPS locator.
AC-DC Power Adapter (Standard accessory)		It is used to charge the internal battery of GL300.
GL300 Data Cable (Optional accessory)		It is the USB data cable which can be used for firmware upgrading and configuration.
GL300 External Cable (Optional accessory)		It is the extend cable which include the charger interface and external battery interface on GL300. It also includes the ignition detection interface on the GL300.

3.2. Battery Charging

- Please connect AC-DC power adapter with GL300.
- Insert the AC-DC power adapter into the power socket.
- During charging, the PWR LED is flashing fast. When the battery is full charged, the PWR LED will be Ever-light.
- You can also charge the battery by USB cable which connects GL300 with the PC.
- Charging time is about 5 hours.

Note: Before the first time using GL300, please full charge the battery.

3.3. GL300 External Cable Interface

- GL300 External Cable is a cable with a Mini USB connector and six wires which include the external power interface, ignition detect and input interface for GL300. Please find the detail description in following table.

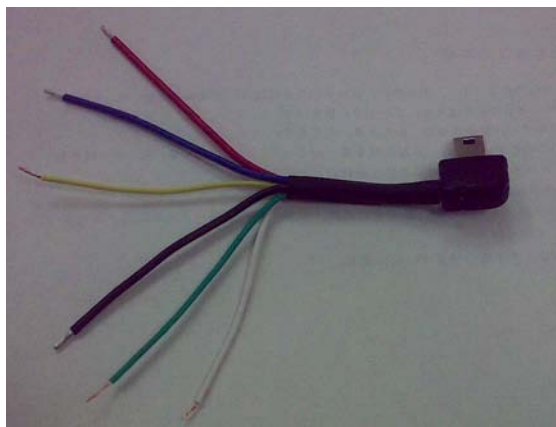

Color	Name	Remark
RED	External DC IN (5V)	Please refer to 2.4.1 for detail
Black	Ground	Please refer to 2.4.1 for detail
Blue	External Battery IN (DC 3.4V to 4.2V)	Please refer to 2.4.2 for detail
White	Ignition Detect	Please refer to 2.5for detail
Green	NSW (negative trigger input)	Please refer to 2.6 for detail
Yellow	OUT(negative trigger output)	Please refer to 2.6 for detail

3.4. Install SIM Card

- First, open the cover of SIM card..
- Then insert the SIM card into the slot of SIM card according to the direction shown.
- Finally, cover the slot.

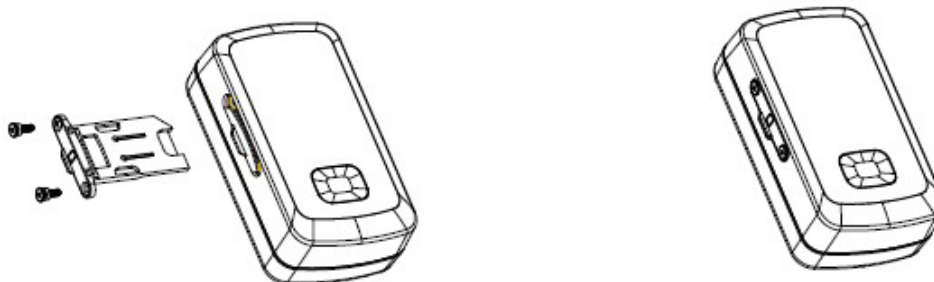

3.5. Turn on/Turn off

- Turn on:
 - ◆ Method 1: Press the Power key at least 3 seconds and release it to turn on GL300. At the same time, PWR LED will light on.
 - ◆ Method 2: Connect device to charger or external battery, and it will turn on automatically, PWR LED will light on.
- Turn off:
 - ◆ Method 1: Press the power key about 2 seconds; PWR LED will fast flash and then turn off, it indicates that GL300 is turned off. The time of power off is depended on the quality of network. The maximum time of power off is 90 seconds. It is only valid to turn off when using internal battery. Please note the end-user can not power off GL300 when the power key is disabled by protocol.
 - ◆ Method 2: If using external battery, device will power turn-off when external battery disconnect.

4. Troubleshooting and Safety info

4.1. Troubleshooting

Trouble	Possible Reason	Solution
After GL300 is turned on, the GSM LED flashes quickly always.	The SIM card is not inserted.	Please insert the SIM card into GL300.
	The signal is too weak; GL300 can't register to the network.	Please move GL300 into place with good GSM coverage.
	PIN locked	Using SIM card without SIM-PIN, or unlock SIM-PIN.
Messages can't be reported to the backend server by GPRS.	The SIM card in GL300 doesn't support GPRS.	Try a GPRS supported SIM card.
	APN is wrong. Some APN can not visit the internet directly.	Ask the network operator for the right APN.
	The IP address or port of the backend server is wrong.	Make sure the IP address for the backend server is an identified address in the internet.
Unable to power off GL300.	The function of power key was disabled by AT+GTFKS.	Enable the function of power key by AT+GTFKS.
	Unable to power off GL300 if charger connected or using external battery.	Disconnect charger or external battery, and try again.
No response from UART when configure GL300 through UART	GL300 is in power saving mode.	Remove the Data_Cable_M, and plug it in again. After this operation, GL300 will exit from power saving mode for 10 seconds.
		Re-try GL300 manager tool again, it will try to wake up device.
GL300 can't get successful GPS fixing.	The GPS signal is weak.	Please move GL300 to a place with open sky.
		It is better to let the top surface face to sky. (The same surface with indication LED)

4.2. Safety info

- Please do not disassemble the device by yourself.
- Please do not put the device on the overheating or too humid place, avoid exposure to direct sunlight. Too high temperature will damage the device or even cause the battery explosion.
- Please do not use GL300 on the airplane or near medical equipment.

WARNING:

This device complies with part 15 of the FCC Rules. Operation is subject to the following two conditions:

- (1) This device may not cause harmful interference, and
- (2) This device must accept any interference received, including interference that may cause undesired operation. Changes or modifications not expressly approved by the party responsible for compliance could void the user's authority to operate the equipment.

NOTE:

This equipment has been tested and found to comply with the limits for a Class B digital device, pursuant to part 15 of the FCC Rules. These limits are designed to provide reasonable protection against harmful interference in a residential installation.

This equipment generates, uses and can radiate radio frequency energy and, if not installed and used in accordance with the instructions, may cause harmful interference to radio communications. However, there is no guarantee that interference will not occur in a particular installation. If this equipment does cause harmful interference to radio or television reception, which can be determined by turning the equipment off and on, the user is encouraged to try to correct the interference by one or more of the following measures:

- Reorient or relocate the receiving antenna.
- Increase the separation between the equipment and receiver.
- Connect the equipment into an outlet on a circuit different from that to which the receiver is connected.
- Consult the dealer or an experienced radio/TV technician for help.

FCC RF Exposure Information and Statement:

The SAR limit of USA (FCC) is 1.6 W/kg averaged over one gram of tissue.

Device types: GL300 (FCC ID:YQD--GL300) has also been tested against this SAR limit.

The highest SAR value reported under this standard during product certification for use on the body is 1.288W/kg.