



GPRS/GPS Tracker **GMT100**
User Manual

TRACGMT100UM001

Revision: 1.04



<http://www.queclink.com>
sales@queclink.com

Document Title	GMT100 User Manual
Version	1.04
Date	2015-10-08
Status	Release
Document Control ID	TRACGMT100UM001

General Notes

Queclink offers this information as a service to its customers, to support application and engineering efforts that use the products designed by Queclink. The information provided is based upon requirements specifically provided to Queclink by the customers. Queclink has not undertaken any independent search for additional relevant information, including any information that may be in the customer's possession. Furthermore, system validation of this product designed by Queclink within a larger electronic system remains the responsibility of the customer or the customer's system integrator. All specifications supplied herein are subject to change.

Copyright

This document contains proprietary technical information which is the property of Queclink Wireless Solutions Co., Ltd. copying of this document and giving it to others and the using or communication of the contents thereof, are forbidden without express authority. Offenders are liable to the payment of damages. All rights reserved in the event of grant of a patent or the registration of a utility model or design. All specification supplied herein are subject to change without notice at any time.

Contents

1. Introduction	7
1.1. Reference	7
1.2. Terms and Abbreviations	7
2. Product Overview	8
2.1. Appearance	8
2.2. Parts List	9
2.3. Interface Definition	9
3. Getting Started	10
3.1. Installing a SIM Card	10
3.2. Switch the set on/off	10
3.3. Reset Key	11
3.4. USB connector.....	11
3.5. Power Connection	11
3.6. Ignition Detection	11
3.7. Digital Input	12
3.8. Analog Input.....	13
3.; . Relay Output	14
3.12. Device Status LED	15

Table Index

Table 1 : GMT100 Protocol Reference	7
Table 2 : Terms and Abbreviations	7
Table 3 : Part List	9
Table 4 : Description of GMT100 User Cable	9
Table 5 : Electrical Characteristics of Ignition Detection	12
Table 6 : Electrical Characteristics of the digital inputs	12
Table 7 : Definition of Device status and LED	16

Figure Index

Figure 1. Appearance of GMT100	8
Figure 2. SIM Card Installation	10
Figure 3. Typical Power Connection.....	11
Figure 4. Typical Ignition Detection	12
Figure 5. Typical Digital Input Connection	13
Figure 6. Typical Analog Input Connection	13
Figure 7. Typical Connection with Siren	14
Figure 8. GMT100 LED on the Case	15

Revision History

Revision	Date	Author	Description of change
V1.00	2011-11-12	Lei	Initial
V1.01	2012-09-29	Lei	1> Replace the picture on the cover 2> Add the de scription and notices of cut relay output in chapter of 3.10 3> Modify the description of t able 7 in chapter of 3.9 4> Update the description of some figures
V1.02	2013-9-16	Owen	change the relay from NO(normal open to NC(Normal close)
V1.03	2013-02-20	Super	change the current and voltage values of relay output from 30A&16V to 20 A & 12V
V1.04	2015-10-08	Super	change the Figure 8(add the diode) and add The relay diode attention description

1. Introduction

The GMT100 is a powerful GPS locator designed for vehicle or asset tracking. It has superior receiver sensitivity, fast TTFF (Time to First Fix) and supports Quad-Band GSM frequencies 850/1900, its location can be monitored in real time or be periodically tracked by a backend server or other specified terminals. The GMT100 has multiple input/output interfaces that can be used for monitoring or controlling external devices. Based on the integrated @Track protocol, the GMT100 can communicate with a backend server through the GPRS network to transfer reports of Emergency, geo-fence boundary crossings, low backup battery or scheduled GPS position as well as many other useful functions. Users can also use GMT100 to monitor the status of a vehicle and control the vehicle by its external relay output. System Integrators can easily setup their tracking systems based on the full-featured @Track protocol.

1.1. Reference

Table 1: GMT100 Protocol Reference

SN	Document name	Remark
[1]	GMT100 @Track Air Interface Protocol	The air protocol interface between GMT100 and backend server.

1.2. Terms and Abbreviations

Table 2: Terms and Abbreviations

Abbreviation	Description
AIN	Analog Input
DIN	Digital Input
DOUT	Digital Output
GND	Ground

2. Product Overview



2.1. Appearance



Figure 1. Appearance of GMT100

2.2. Parts List

Table 3: Part List

Name	Picture
GMT100 Locator	
DATA_CABLE_M (Optional)	

2.3. Interface Definition

There are 8 wires on GMT100 User Cable which contain the connection for power, ignition input, digital input, analog input, siren output, cut output etc. The user cable's definition is shown in following table.

Table 4: Description of GMT100 User Cable

Index	Colour	Description	Comment
1	Red	Power	External DC power input, 12/24V
2	Black	Ground	System ground (connect to the vehicle's frame directly)
3	White	Ignition	Ignition input, positive trigger
4	Blue	Digital input	Digital input, negative trigger
5	Green	Analog input	Analog input, 12/24V
6	Brown	Siren output	Siren output, high end
7	Yellow	Relay output line1	Internal relay output line1.
8	Yellow	Relay output line2	Internal relay output line2

3. Getting Started

3.1. Installing a SIM Card

Step 1: Remove the cover by screwdriver.

Step 2: Make sure the contact area is facing down, insert the SIM into the slot.

Step 3: Install the SIM card cover.

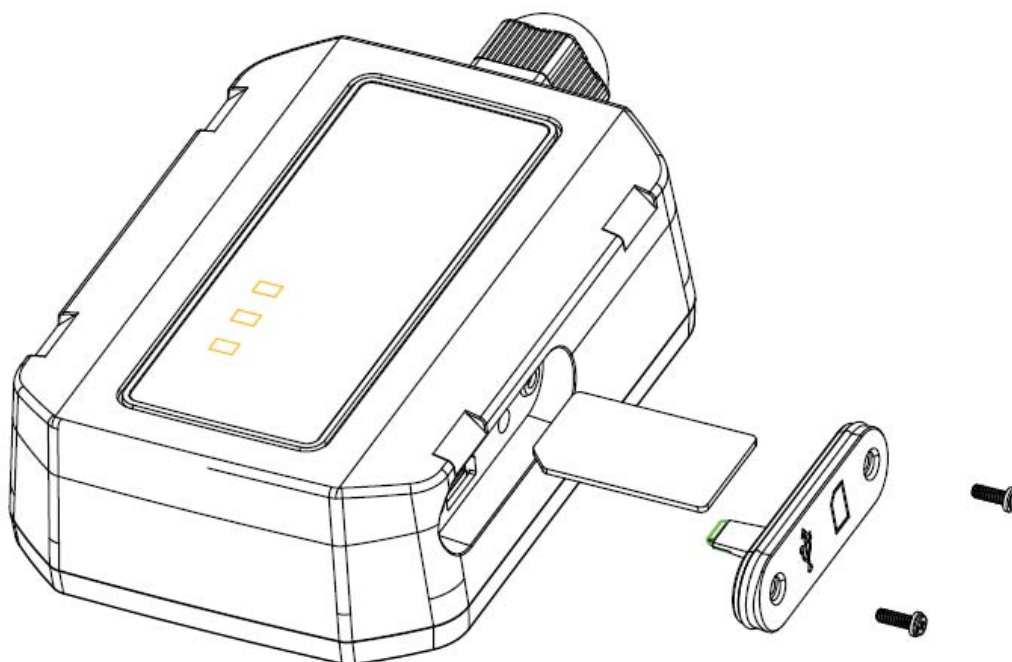

Figure 2. SIM Card Installation

3.2. Switch the set on/off

There are two methods to Power on GMT100:

- GMT100 external power turned on.
- Connect GMT100 to PC with user cable.

When the external power or USB cable power be removed, GMT100 will switch to internal backup battery and keep on running. When internal backup battery is exhausted, GMT100 will give a report and then turn off.

Note:

- 1-External power and User USB power can be present at same time.
- 2-For USB port current limitation, when configuring GMT100 by user cable, please let backup battery on using.

There is one method to turn off GMT100.

-Remove the external power and USB power.

-Press the reset key.

Note:

GMT100 PWR LED will off.

3.3. Reset Key

There is a reset key behind the SIM card cover. If the power wire is connected to vehicle power, the system will reboot when the key is pressed; if the system is powered by the backup battery and the power wire is not be connected to vehicle power, the system will shutdown when the key is pressed.

Note:

When you finished the firmware upgrade, please press the reset key to reboot the system before configuring the terminal.

3.4. USB connector

There is a USB connector on GMT100 which is beside the SIM card. With the USB connector and the DATA_CABLE_M, user can configure the system or download firmware. As long as the DATA_CABLE_M is plugged in, the system will boot.

3.5. Power Connection

The red wire is power wire and the black wire is ground wire. The input voltage range for this device is from 12 to 24V. The device is designed to be installed in vehicles that operate on 12V or 24V systems without the need for external transformers.

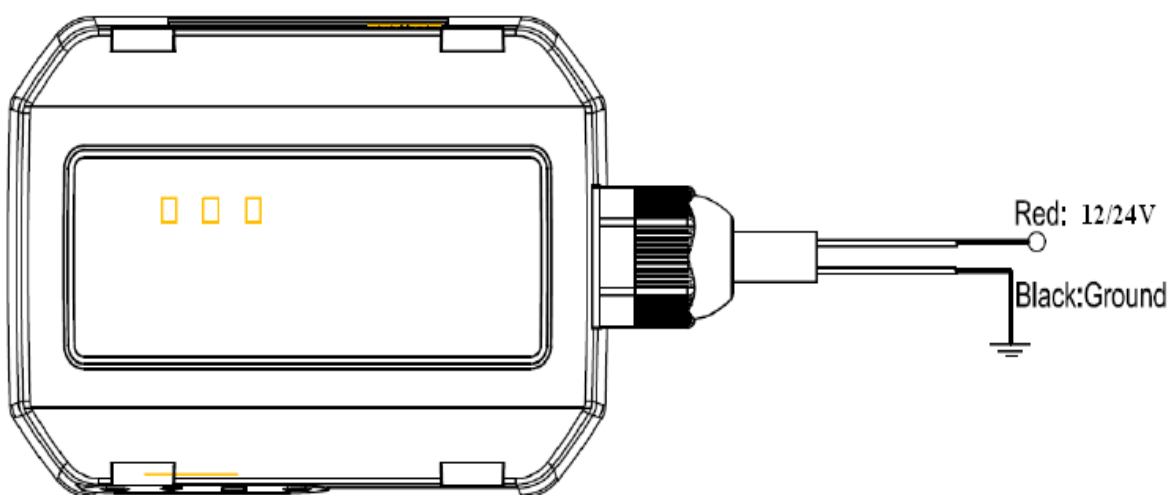

3.6. Ignition Detection

Table 5: Electrical Characteristics of Ignition Detection

Logical State	Electrical State
Active	12/24V
Inactive	0V to 3V or Open

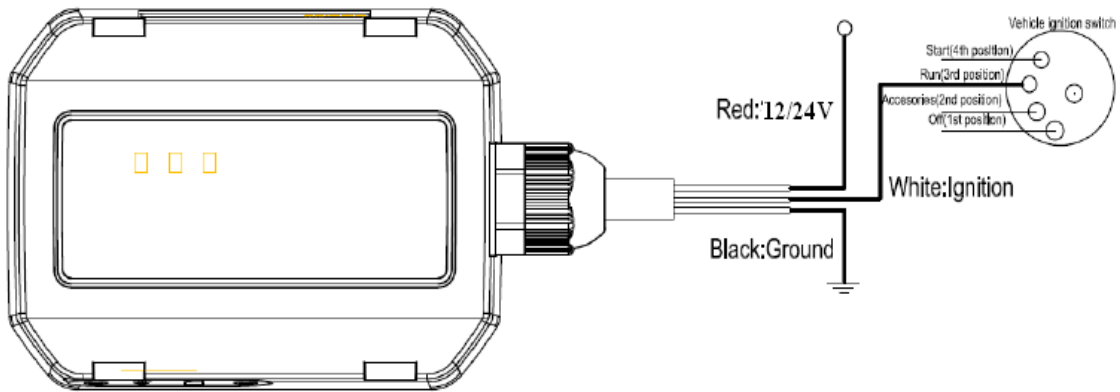

Figure 4. Typical Ignition Detection

The white wire is used for ignition detection. It is strongly recommended to connect this wire to ignition key “RUN” position as shown up.

An alternative to connecting to the ignition switch is to find a non permanent power source that is only available when the vehicle is running. For example the power source for the FM radio.

Ignition signal can be configured to start transmitting information to backend server when ignition is on; and enter power saving mode when ignition is off.

3.7. Digital Input

There is a general purpose digital input which is the blue wire on GMT100 User Cable, and it is a negative trigger. The digital input is recommended to support panic button function.

Table 6: Electrical Characteristics of the digital inputs

Logical State	Electrical Characteristics
Active	0V to 0.8V
Inactive	Open

The following diagram shows the recommended connection of the digital input.

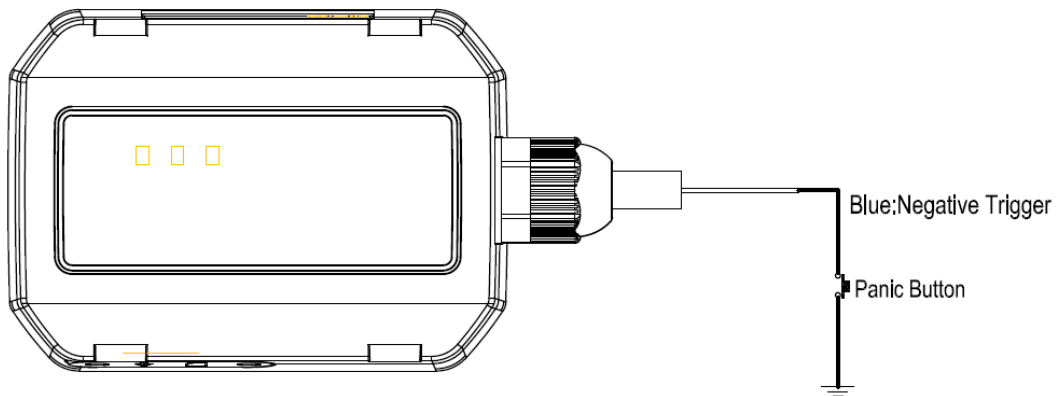

Figure 5. Typical Digital Input Connection

3.8. Analog Input

There is an analog input which is the green wire on GMT100 User Cable, and the analog input voltage range is 12/24V. The following diagram shows the recommended connection.

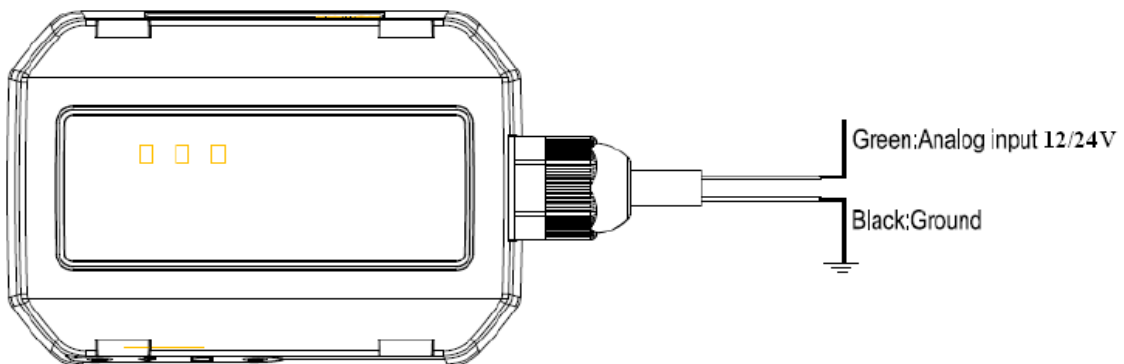

Figure 6. Typical Analog Input Connection

3.3. Relay Output

There is a built-in cut relay on GMT100, and it is a NC(Normal Close) type relay with maximum switching voltage is 12VDC and maximum continuous current is 20A. On GMT100 user cable one 18AWG yellow wire is connected to the relay NC contact and the other 18AWG yellow wire is connected to the relay COM contact. In certain instances the two wires will be connected together.

Note:

- 1: The relay output can be latched by the software, so even if the GMT100 is restart or power down in some cases, the relay output will not change. To use the latch function the main power and backup battery should be connected. Otherwise the relay will be always in normal close status.
- 2: The relay works only with 12V main power. Use it when the main power is 24V may result in damaging.
- 3: Many modern relays come with a flyback diode pre-installed internal to the relay itself. If the relay has this diode, ensure the relay polarity is properly connected. If this diode is not internal, it should be added externally. A common diode such as a 1N4004 will work in most circumstances.

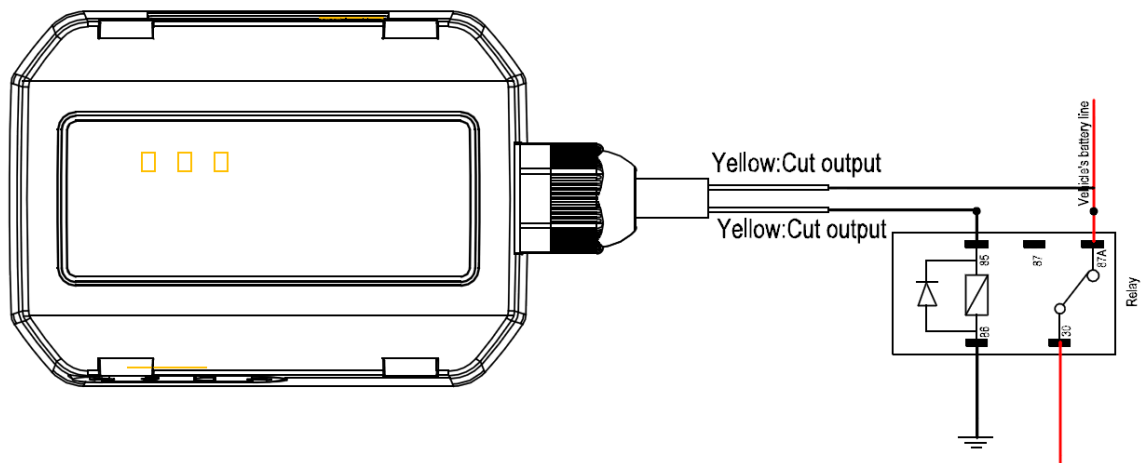

Figure 7. Typical Connection with Relay

3.12. Device Status LED

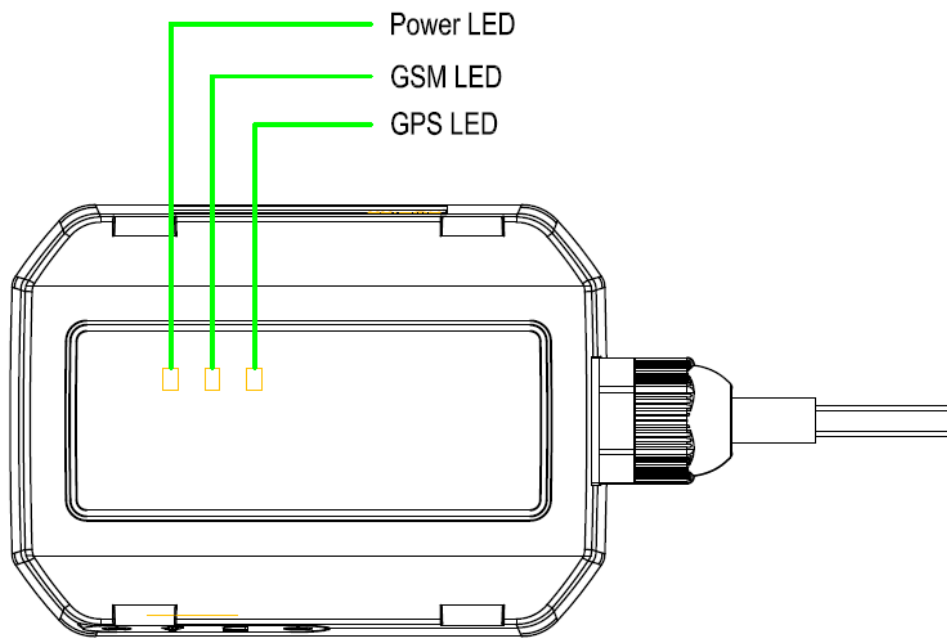

Figure 8. GMT100 LED on the Case

Table 9: Definition of Device status and LED

LED	Device status	LED status
GSM (note1)	Device is searching GSM network	Fast flashing (Note3)
	Device has registered to GSM network.	Slow flashing (Note4)
	SIM card needs pin code to unlock.	ON
GPS (note 2)	GPS chip is powered off	OFF
	GPS sends no data or data format error.	Slow flashing
	GPS chip is searching GPS info.	Fast flashing
	GPS chip has gotten GPS info.	ON
PWR (note 2)	No external power and backup battery voltage is lower than 3.35V.	OFF
	No external power and backup battery voltage is below 3.5V.	Slow flashing
	External power in and backup battery is charging	Fast flashing
	External power in and backup battery is fully charged	ON

Note:

- 1 - GSM LED cannot be configured.
- 2 - GPS LED and PWR LED can be configured to turn off after a period of time using the configuration tool
- 3 - Fast flashing is about 60ms ON/ 780ms OFF
- 4 - Slow flashing is about 60ms ON/ 1940ms OFF

FCC Warning:

Any Changes or modifications not expressly approved by the party responsible for compliance could void the user's authority to operate the equipment.

This device complies with part 15 of the FCC Rules. Operation is subject to the following two conditions: (1) This device may not cause harmful interference, and (2) this device must accept any interference received, including interference that may cause undesired operation.

FCC Radiation Exposure Statement:

This equipment complies with FCC radiation exposure limits set forth for an uncontrolled environment. This equipment should be installed and operated with minimum distance 20cm between the radiator & your body.

This transmitter must not be co-located or operating in conjunction with any other antenna or transmitter.